

COSEL

[POWER SUPPLY]
[NOISE FILTER]

2023
2024

PRODUCT CATALOG



Before using our product

■ Warning

- ◆ When the product is in operation, inside there are components which have high voltage and high temperature. They may cause electrical shock or burn if you touch the internal components.
- ◆ Do not modify, disassemble or remove the enclosure of the product. This may cause electrical shock, burn or fire hazard.
- ◆ When the product is operating, keep your hands and face away from it. This may cause injury by accident.

■ Attention

- ◆ It is necessary to read the instruction manual and catalog. Please confirm the content of the catalog and instruction manual before you use our products.
- ◆ We make every effort to improve quality and reliability of our products. However the product may accidentally malfunction or fail. Therefore, please ensure fail safe function of your product when our product is used in equipment where high reliability is required (such as nuclear control, aerospace, life-support, traffic control etc.).
- ◆ If the product is used in an environment where water, moisture, dust, strong electromagnetic field or corrosive gas is present, it may cause the failure of the internal components of the product.
- ◆ The life-limited components (such as electrolytic capacitor, internal fan.) should be replaced periodically. Please arrange for the appropriate overhaul period depending on the usage environment.
- ◆ When you export the product, please comply with all appropriate export-related laws, and procedures.

* The content of the catalog may be changed without advanced notice.
If necessary, please request product specification from our representatives before ordering.

Environmentally Friendly Products and its Symbol

We have developed a new internal evaluation system on environmental burdens in order to provide our customers with information on our products and our efforts to promote the development of environmentally friendly products since 2010.

We are looking at the following 3 items in evaluating our products to reduce their environmental burdens.

- (1) Environmental burdens generated when our products are in operation at customers' site.
- (2) Environmental burdens generated when our products are manufactured at our factories.
- (3) Environmental burdens generated when materials and components we purchase are manufactured.

Based on the above 3 items, we set our own criteria to certify and register products which satisfy our criteria as "Eco Products." These Eco Products are highly efficient in reducing environmental burdens. To promote Eco Products, we developed the following symbol which represent Eco Products.



We will proactively expand our Eco Products to create an environmentally friendly low-carbon recycling-oriented society and to continue to grow with our customers.



Table of contents

Outline	2
Products line	4
Selection guide (Type)	6
Repair and Service	10
● Enclosed Type	
PCA series	11
PBA · PBW series	31
PJA series	67
PLA series	83
AEA series	93
HCA series	103
FETA series	109
SC series	129
● Open Frame/ Enclosed Type	
LHA series	139
LFA series	163
LGA series	187
LHP series	201
LFP series	209
● PCB Mount Type	
TUHS series	221
MG series	235
MH series	309
SUS · SUW/SUCS · SUCW/SUTS · SUTW series	321
■ Value-added Type	
STMG series	371
● POL Type	
BRNS series	391
BRFS/BRDS series	397
● Bus Converter - Power Module Type	
CHS series	411
CQHS series	449
DHS series	461
TUNS series	477
TUXS series	495
DPG series	503
DPF series	509
● Configurable Type	
AME series	515
● DIN Rail Type	
KH series	527
WDA series	547
KL series	557
KR series	565
● Medical Type	
LMA series	571
UMA series	581
GMA series	587
GHA series	593
PJMA series	609
PMA series	621
● EMI/EMC Filter	
Selection Guide	634
Technical Notes	639
EAC/EAM/EAP series	656
ESC/ESM/ESP series	658
NAC/NAM/NAH/NAP series	664
NBH/NBC/NBM series	678
JAC series	684
TAC/TAH series	696
FTA series	718
YAC series	732
TBC series	736
FTB series	744
FSB series	750
TSC · TSD series	768
SNA/SNR series	780

- PCA
- PBA/PBW
- PJA
- PLA
- AEA
- HCA
- FETA
- SC
- LHA
- LFA
- LGA
- LHP
- LFP
- TUHS
- MG
- MH
- SUS/SUCS
- STMG
- BRNS
- BRFS/BRDS
- CHS
- CQHS
- DHS
- TUNS
- TUXS
- DPG
- DPF
- AME
- KH
- WDA
- KL
- KR
- LMA
- UMA
- GMA
- GHA
- PJMA
- PMA
- EMI/EMC Filter

OUTLINE



■ Head office / R&D center



■ Tateyama factory

Company Guidance

- Established : July 26, 1969.
- Paid Capital : 2,055 Million Yen
- CEO : Morio Saito
- Annual Sales : 35,266 Million Yen (As of May 2023)
(Consolidated)
- Employees : 707 (As of May 2023)
- Subsidiaries : COSEL U.S.A., INC.
COSEL EUROPE GmbH
COSEL ASIA LTD.
COSEL (SHANGHAI) ELECTRONICS CO., LTD.
WUXI COSEL ELECTRONICS CO., LTD.
SHANGHAI COSEL INTERNATIONAL TRADING CO., LTD.
COSEL VIETNAM CO., LTD
POWERBOX INTERNATIONAL AB

- History :
 - J u l . 1969 Established ELCO CO., LTD.
 - A p r . 1978 Introduced QC circle activities.
 - J u n . 1978 Became Pure-Power Supply Business-Play.
 - M a y . 1982 Introduced TQC activities (Now changed to TQM activities).
 - J u n . 1983 Introduced Hoshin Management (Business Goal Management) activities.
 - M a r . 1988 Introduced Toyota Production System activities.
 - M a r . 1989 Tateyama Factory completed.
 - A p r . 1990 Established COSEL U. S. A., INC. (Former U. S. ELCO INC.) in San Jose, USA.
 - A p r . 1992 Changed company name to COSEL CO., LTD. from ELCO CO., LTD.
 - J u n . 1993 Acquired ISO9001.
 - M a y . 1995 Set a representative in Hong Kong, China.
 - M a y . 1996 Introduced TPM (Total Plant Maintenance) activities.
 - J u l . 1997 Established COSEL EUROPE GmbH in Frankfurt, Germany.
 - M a y . 1998 Established COSEL ASIA LTD. in Hong Kong, China.
 - J a n . 1999 Shares listed on the Second Sections of the Tokyo Stock Exchange and Nagoya Stock Exchange both.
 - Dec. 1999 Acquired ISO14001.
 - M a y . 2000 Shares listed on the First Section of the Tokyo Stock Exchange.
 - N o v . 2002 Established COSEL (SHANGHAI) ELECTRONICS CO., LTD. in Shanghai, China.
 - M a r . 2005 Entering EMI filter Business.
 - F e b . 2006 Successfully completed the RoHS Directive conformity.
 - N o v . 2011 Established SHANGHAI COSEL INTERNATIONAL TRADING CO., LTD. in Shanghai, China.
 - Dec. 2011 Established WUXI COSEL ELECTRONICS CO., LTD. in Wuxi, China.
 - A u g . 2015 Established COSEL VEITNAM CO., LTD in Ho Chi Minh City, Vietnam.
 - J u n . 2018 Acquired POWERBOX INTERNATIONAL AB.
 - O c t . 2018 Began operations at R&D Center.

Data



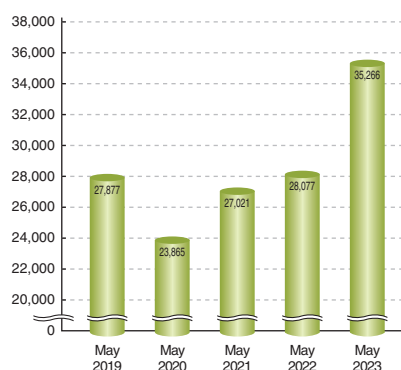



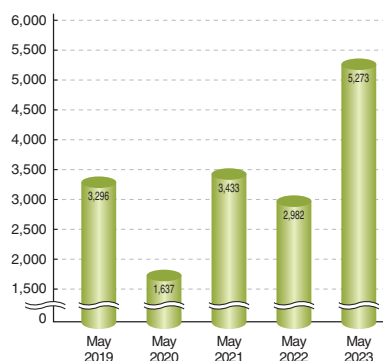





Annual sales
(Consolidated)
(Unit: Million Yen)







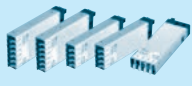
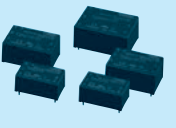

Ordinary income
(Consolidated)
(Unit: Million Yen)

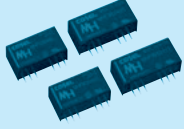

AC-DC Power Supplies

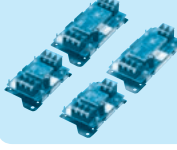
Enclosed Type	Single output					
	PCA series	PLA series	PJA series	FETA series	HCA series	
						
	Open Frame / Enclosed Type					
	LHA series	LHP series				
						
DIN Rail Type	Single output		Redundancy Module		Medical Type	
	WDA series	KH series	KL series	KR series		
						
						Single/Multiple output
						AEA series
						
Configurable Type	Multiple output		Single output			
	AME series	TUHS series				
						

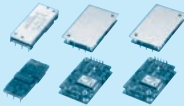
DC-DC Converters

PCB Mount Type	Single/Multiple output		Value-added	
	MG series	MH series	SUS-SUW/SUCS-SUCW SUTS-SUTW series	STMG series
				
Bus Converter - Power Module Type	Single output			
	CHS series	CQHS series	DHS series	DBS series
				

FCA series

WEB

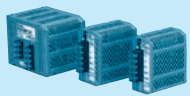

UMA series

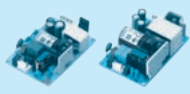

PJMA series



GMA series



GHA series

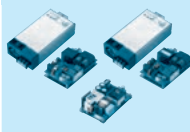

LMA series



**Bus Converter-
Power Module Type**

Single output

TUNS series

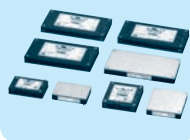

TUXS series

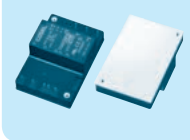

PFC Front-end module

DPG series



DPF series

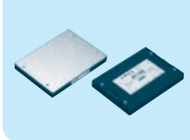

POL Type

Single output

BRNS series



BRFS/BRDS series

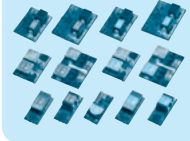

[Notice]

WEB : Specifications available on the Cosel website only.

PCA
PBA/PBW
PJA
PLA
AEA
HCA
FETA
SC

LHA
LEA
LGA
LHP
LFP

TUHS
MG
MH
SU/SU/SUT

STMG

BRNS
BRFS/BRDS

CHS
CQHS
DHS
TUNS
TUXS
DPG
DPF

AME

KH
WDA
KL
KR

LMA
UMA
GMA
GHA
PJMA
PMA

EMI/EMC
Filter

Cosel with the global safety standards

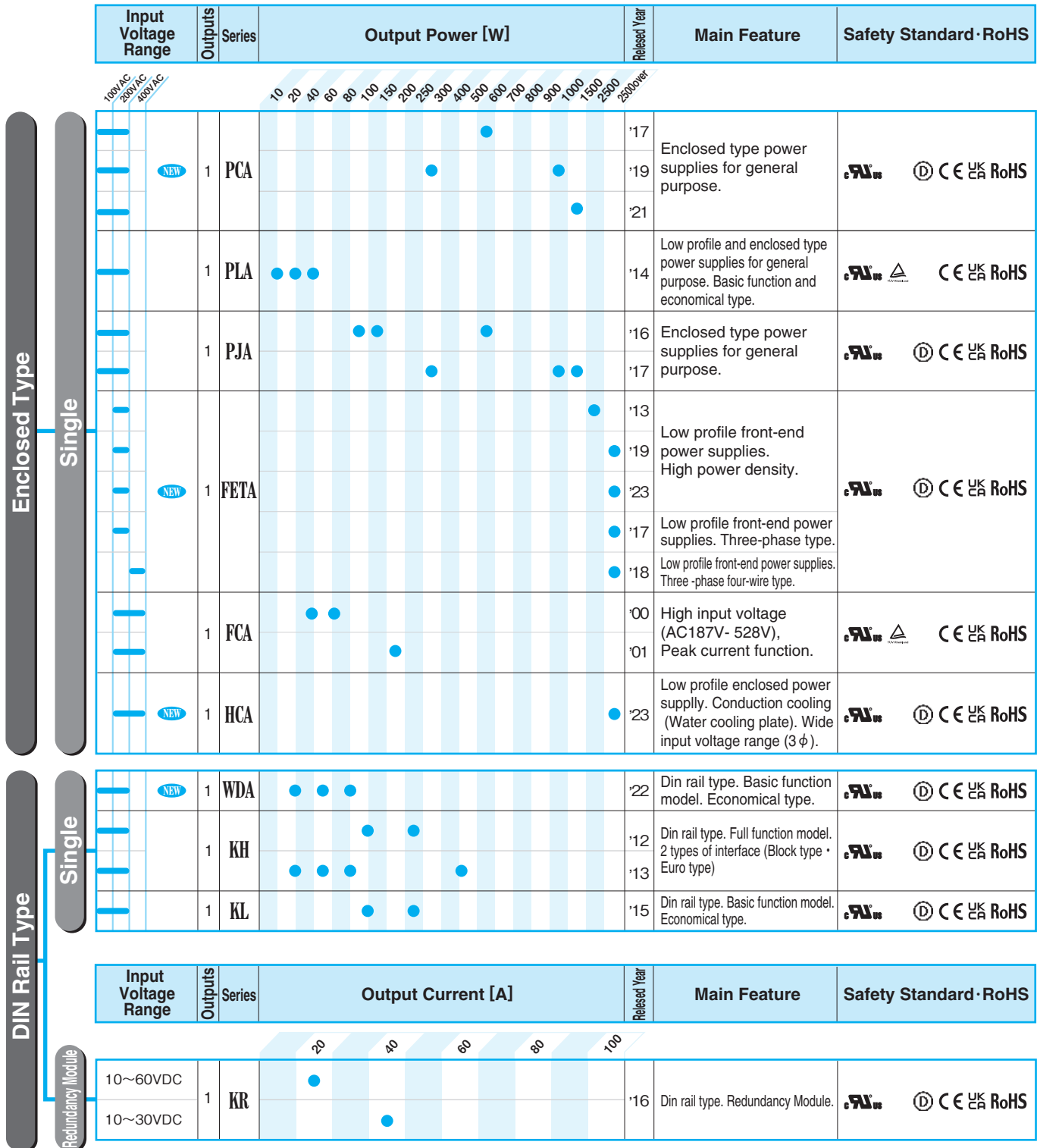

POL Type

Single

Input Voltage Range	Outputs	Series	Output Current [A]											Released Year	Main Feature	Safety Standard · RoHS
			6	12	20	30	40	60	100	120	150					
3~14.4VDC	1	BRNS	●	●	●									'13	Compact size · Wide input	
4.5~14.0VDC	1	BRFS				●								'13	Compact size · Fast transient response	
							●	●	●				'14	Compact size · Fast transient response		
											●	●	'18	Compact size · Fast transient response		
4.5~14.0VDC	1	BRDS					●	●	●				'17	Compact size · Fast transient response, PMBus		
													'18			

Bus Converter · Power Module Type

Single

Input Voltage Range	Outputs	Series	Output Power [W]											Released Year	Main Feature	Safety Standard · RoHS		
			40	80	100	150	200	300	400	500	1000	1500						
90DC 12VDC 24VDC 48VDC 85VDC 110VDC 280VDC	1	CHS													'17	DC24V input bus converter, 1/16 brick size		
															'15	DC24V input bus converter, 1/8 brick size		
																'18		DC24V input bus converter, 1/4 brick size
																'14		DC48V input bus converter, 1/32 brick size
																'11		DC48V input bus converter, 1/16 brick size
																'16		DC48V input bus converter, 1/8 brick size
																'11		DC48V input bus converter, 1/8 brick size
																'13		DC48V input bus converter, 1/8 brick size
																'17		DC48V input bus converter, 1/8 brick size
																'13		DC48V input bus converter, 1/4 brick size
													'18					
100VAC 200VAC 277VAC	1	CQHS													'10	DC48V input, brick Size		
															'13	DC48V input, brick Size		
															'14			
100VAC 200VAC 277VAC	1	DHS													'10	DC110V input, small brick size		
															'09	DC280V input, small brick size		
100VAC 200VAC 277VAC	1	DBS													'00	DC280V input, full function and full brick size		
100VAC 200VAC 277VAC	1	TUXS													'15	100/200VAC input. High efficiency. Complied with harmonic regulations. Isolated type.		
															'17			
																'12		100/200VAC input. Complied with harmonic regulations. Isolated type. Brick size
																'14		100/200VAC input. Complied with harmonic regulations. Isolated type. Brick size
																'15		100/200VAC input. Complied with harmonic regulations. Isolated type. Brick size
100VAC 200VAC 277VAC	1	TUNS													'20	100/200/277VAC input. full function. Complied with harmonic regulations.		
															'10	100/200VAC input. Compact size. Complied with harmonic regulations.		
															'00	100/200VAC input. High wattage. Complied with harmonic regulations.		
100VAC 200VAC 277VAC	1	DPG													'10	100/200VAC input. Compact size. Complied with harmonic regulations.		
															'00	100/200VAC input. High wattage. Complied with harmonic regulations.		

PCB Mount Type

Single

Multiple

Input Voltage Range	Outputs	Series	Output Power [W]												Released Year	Main Feature	Safety Standard - RoHS	
			1.5	3	5	6	10	15	20	25	30	40	80					
5VDC 12VDC 24VDC 48VDC 110VDC 280VDC	1	MGS														'10	Global standard DC/DC converter for general purpose.	UL, CE, RoHS
																'16		UL, CE, RoHS
	1	MGFS														'10	Wide-input global standard DC/DC converter for general purpose.	UL, CE, RoHS
																'17		UL, CE, RoHS
																'19		UL, CE, RoHS
	1	MGXS														'18	Wide-input (DC6-60V) global standard DC/DC converter.	UL, CE, RoHS
	1	STMG														'13	Value-added type of MGFS series	CE, RoHS
															'21			
	1	MHFS														'20	DC/DC Converters with 4.2kVDC Isolation	UL, CE, RoHS
															'22			
	1	SUS/SUCS														'04	Compact and thin DC/DC Converter for general purpose	UL, CE, RoHS
	1	SUTS														'09	Vertical type of SUCS series	UL, CE, RoHS
100VAC 200VAC 277VAC	1	TUHS														'14	AC100/200V input, compact size	UL, CE, RoHS
															'15			
5VDC 12VDC 24VDC 48VDC 110VDC 280VDC	2	MGW														'10	2 outputs of MG series	UL, CE, RoHS
																'16		UL, CE, RoHS
	2	MGFW														'10	Wide-input global standard DC/DC converter for general purpose.	UL, CE, RoHS
																'17		UL, CE, RoHS
																'19		UL, CE, RoHS
	2	MGXW														'18	2 outputs of MGX series	UL, CE, RoHS
	2	STMG														'13	Value-added type of MGFW series	CE, RoHS
	2	MHFW														'20	DC/DC Converters with DC4.2kVDC Isolation	UL, CE, RoHS
															'22			
	2	SUW/SUCW														'04	SU series with metal cover	UL, CE, RoHS
	2	SUTW														'09	Vertical type of SUCW series	UL, CE, RoHS



*The catalog is not listed some products like "Not recommended for new design" and "Not enough time before Last Time Buy". If you see all product information, please see Cosel website (<https://en.cosel.co.jp>) for the details.

- PCA
- PBA/PBW
- PJA
- PLA
- AEA
- HCA
- FETA
- SC
- LHA
- LFA
- LGA
- LHP
- LFP
- TUHS
- MG
- MH
- SUS/SUCS
- STMG
- BRNS
- BRNS/BRDS
- CHS
- CQHS
- DHS
- TUNS
- TUXS
- DPG
- DPF
- AME
- KH
- WDA
- KL
- KR
- LMA
- UMA
- GMA
- GHA
- PJMA
- PMA
- EMI/EMC Filter

When a failure in product is found, contact our distributors or our sales subsidiaries.

1. Free Repair

Repair is free of charge when the following cases apply:

- (1) If the product returned is still within warranty period and damages are due to component failure.
- (2) Damages are due to Cosel's manufacturing and design errors.

2. Charged Repair

Repair is charged when the following cases apply:

- (1) Products' warranty period has expired.
- (2) Electrical or physical damages are caused by customer.
- (3) The product returned is over 6 months from first operation but no problem is found after analysis.
- (4) Damages are due to use outside of our published specifications.
- (5) Damages are caused by Acts of God such as fire, flood, earthquake, etc.
- (6) Time-deteriorating parts such as electrolytic capacitors, cooling fans, etc. are replaced.

3. Warranty After Repair

- (1) As for the products whose regular warranty period has expired, the repaired products will have a 3-month warranty.

4. Repair and Service Network

When a failure in product is found, please return the products in the following way:

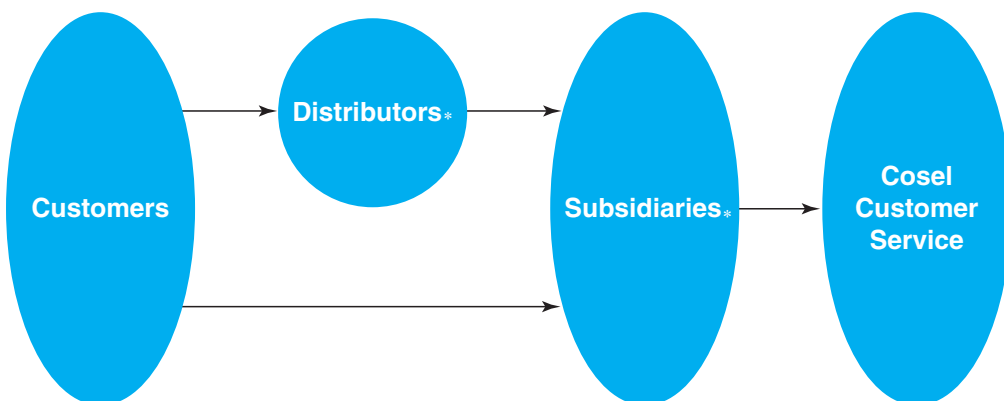

* Please refer to Sales Network in this catalog.



PCA-series

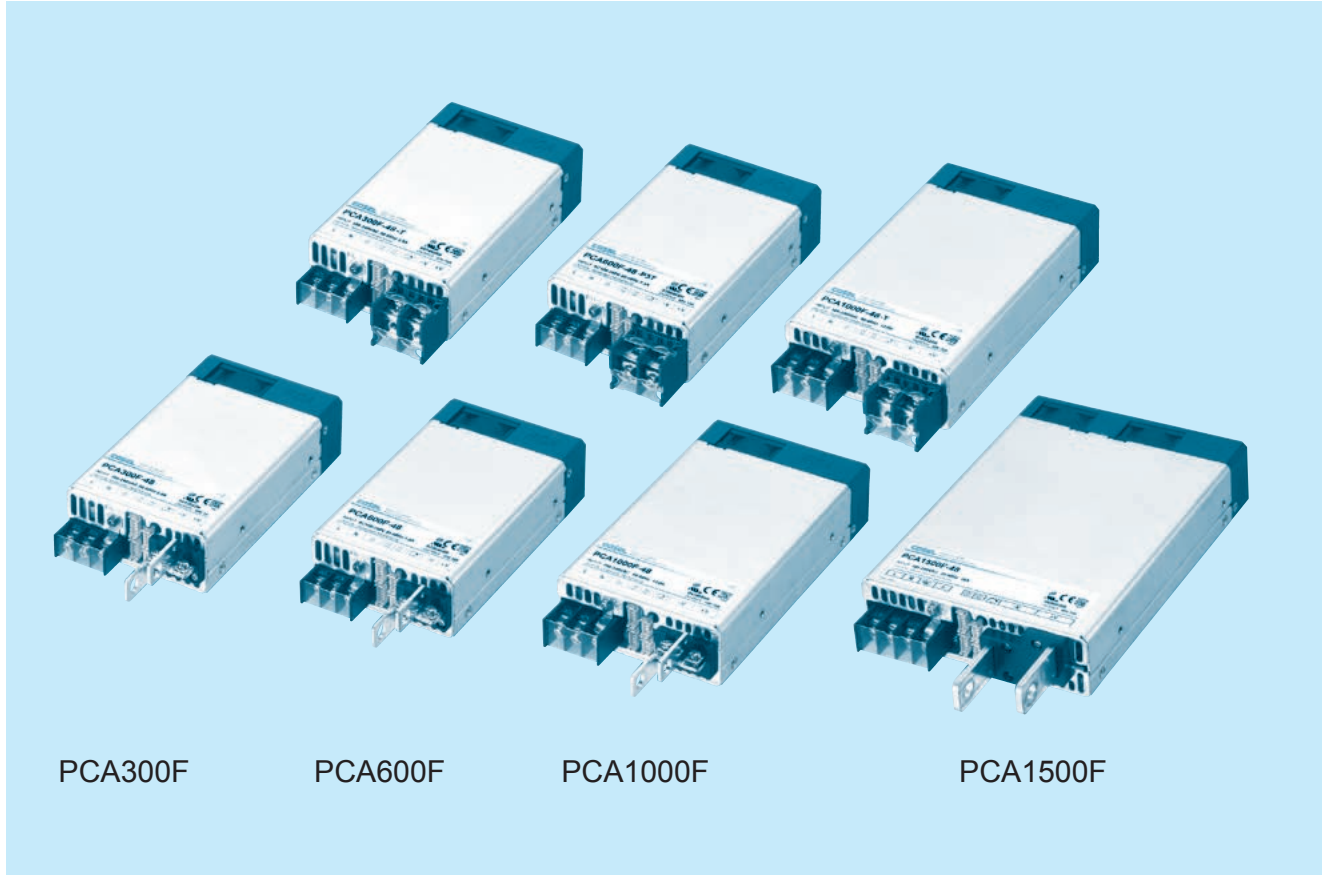

PCA300F

PCA600F

PCA1000F

PCA1500F

Feature

- Low profile (41mm, 1.61 inch = meet 1U height)
- Universal input 85 - 264VAC
(Refer to "Input voltage Derating")
- DC input 88 - 370VDC possible : Excluding PCA1000F and PCA1500F
(Refer to "Input voltage Derating")
- For medical electric equipment (ANSI/AAMI ES60601-1, EN60601-1 3rd)
- Medical Isolation Grade 2MOPP
- With AUX output 12V 0.1A (Voltage adjustable range 5 - 12V)
- Constant current function
- Output voltage can be adjusted to near 0V (the item 2.6 on Instruction Manual)
- With various alarms
- Parallel Operation / N+1 Parallel Redundancy Operation possible
- Monitoring function and various setting values can be changed by communication (the item 2.11 on Instruction Manual)
- UL508 (Optional)

Safety agency approval

- UL62368-1, C-UL (CSA62368-1), EN62368-1, ANSI/AAMI ES60601-1, EN60601-1 3rd
- UL508 (Optional)

Up to 5-year warranty (Refer to Instruction Manual)

CE marking

- Low Voltage Directive
- RoHS Directive

UKCA marking

- Electrical Equipment Safety Regulations
- RoHS Regulations

EMI

- PCA300F, PCA600F
Complies with FCC-B, CISPR32-B, EN55011-B, EN55032-B, VCCI-B
- PCA1000F, PCA1500F
Complies with FCC-A, CISPR32-A, EN55011-A, EN55032-A, VCCI-A

EMS Compliance : EN61204-3, EN61000-6-2

IEC60601-1-2 (2014), EN60601-1-2 (2015)

- EN61000-4-2
- EN61000-4-3
- EN61000-4-4
- EN61000-4-5
- EN61000-4-6
- EN61000-4-8
- EN61000-4-11

PCA300F

PC A 300 F -5 -□

① ② ③ ④ ⑤ ⑥

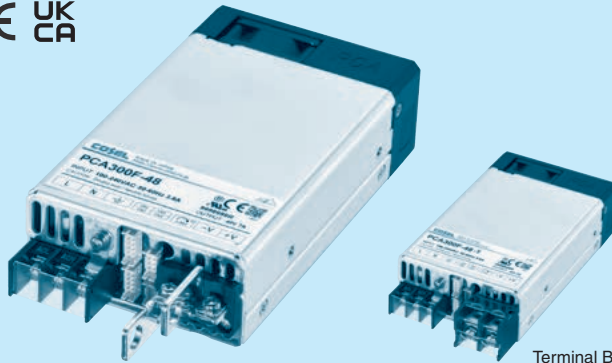
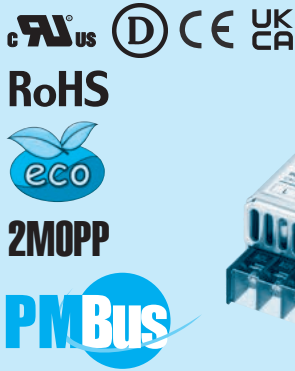

Example recommended EMI/EMC filter
NAC-06-472



High voltage pulse noise type : NAP series
Low leakage current type : NAM series
Low profile type : EAC series

*A higher current rating EMI/EMC filter may be recommended in view of the other devices that could be connected in parallel with the power supply.

- ① Series name
- ② Single output
- ③ Output wattage
- ④ Universal input
- ⑤ Output voltage
- ⑥ Optional *7
C :with Coating
G :Low leakage current
T : Terminal Block Style
I :with PMBus interface
F2 :Reverse air exhaust type
P3 :Master-slave Operation
W1 :Alarm function
T5 :UL508

For option details, refer to instruction manual 6.1.

*Make sure necessary tests will be carried out on your end equipment with the power supply installed in accordance with any required EMC/EMI regulations.

MODEL	PCA300F-5	PCA300F-12	PCA300F-15	PCA300F-24	PCA300F-32	PCA300F-48
MAX OUTPUT WATTAGE[W]	300	324	330	336	320	336
DC OUTPUT	5V 60A	12V 27A	15V 22A	24V 14A	32V 10A	48V 7A

SPECIFICATIONS

MODEL		PCA300F-5	PCA300F-12	PCA300F-15	PCA300F-24	PCA300F-32	PCA300F-48	
INPUT	VOLTAGE	[VAC] 85 - 264 1 φ						
		[VDC] *1 88 - 370						
	CURRENT[A]	ACIN 100V 3.8typ						
		ACIN 230V 1.6typ						
	FREQUENCY[Hz]	50/60 (45 - 66)						
	EFFICIENCY[%]	ACIN 100V	(Io=50%) 86typ	87typ	87typ	88typ	88typ	88typ
			(Io=100%) 87typ	88typ	88typ	89typ	89typ	89typ
		ACIN 230V	(Io=50%) 87typ	88typ	88typ	89typ	89typ	89typ
			(Io=100%) 89typ	90typ	90typ	91typ	91typ	91typ
	POWER FACTOR	ACIN 100V	0.98typ (Io=100%)					
ACIN 230V		0.95typ (Io=100%)						
INRUSH CURRENT[A]	ACIN 100V*2	20/40 typ (Io=100%) (Primary inrush current / Secondary inrush current) (More than 3 sec. to re-start)						
	ACIN 230V*2	40/40 typ (Io=100%) (Primary inrush current / Secondary inrush current) (More than 3 sec. to re-start)						
LEAKAGE CURRENT[ma]	0.5max (ACIN 240V 60Hz, Io=100%, According to IEC60601-1)							
OUTPUT	VOLTAGE[V]	5	12	15	24	32	48	
	CURRENT[A]	60	27	22	14	10	7	
	LINE REGULATION[mV]	20max	48max	60max	96max	128max	192max	
	LOAD REGULATION[mV]	40max	100max	120max	150max	150max	480max	
	RIPPLE[mVp-p]	0 to +50°C *3*4	160max	240max	240max	240max	320max	480max
		-20 to 0°C *3	280max	320max	320max	320max	420max	640max
	RIPPLE NOISE[mVp-p]	0 to +50°C *3*4	240max	300max	300max	300max	400max	600max
		-20 to 0°C *3	320max	360max	360max	360max	480max	720max
	TEMPERATURE REGULATION[mV]	0 to +50°C *4	50max	120max	150max	240max	320max	480max
		-20 to +50°C *4	75max	180max	180max	290max	400max	600max
	DRIFT[mV]	*5 20max	48max	60max	96max	128max	192max	
	START-UP TIME[ms]	700typ (ACIN 100/230V Io=100%)						
	HOLD-UP TIME[ms]	20typ (ACIN 230V Io=80%) / 16typ (ACIN 230V Io=100%)						
OUTPUT VOLTAGE ADJUSTMENT RANGE[V]	3.00 to 6.00	7.20 to 14.40	9.00 to 18.00	14.40 to 28.80	19.20 to 38.40	28.80 to 57.60		
OUTPUT VOLTAGE SETTING[V]	5.00 to 5.05	12.00 to 12.12	15.00 to 15.15	24.00 to 24.24	32.00 to 32.32	48.00 to 48.48		
PROTECTION CIRCUIT AND OTHERS	OVERCURRENT PROTECTION	Works over 105% of rating (Recovers automatically, Hiccup overcurrent)						
	OVERVOLTAGE PROTECTION[V]	6.25 to 7.00	15.00 to 16.80	18.75 to 21.00	30.00 to 33.60	40.00 to 44.80	60.00 to 67.20	
	REMOTE SENSING	Provided						
	REMOTE ON/OFF (RC)	Provided						
	DC_OK LAMP	LED (Blue)						
	ALARM LAMP	LED (Orange)						
COMMUNICATION FUNCTION	Provided (Extended UART)							
ISOLATION	INPUT-OUTPUT	AC4,000V 1minute, Cutoff current = 10mA, DC500V 50MΩ min (At Room Temperature) 2MOPP						
	INPUT-FG	AC2,000V 1minute, Cutoff current = 10mA, DC500V 50MΩ min (At Room Temperature) 1MOPP						
	OUTPUT-FG	AC500V 1minute, Cutoff current = 100mA, DC500V 50MΩ min (At Room Temperature)						
	OUTPUT-AUX·RC·PG·INFO·DS·ADDR0·ADDR1·ADDR2	AC500V 1minute, Cutoff current = 100mA, DC500V 50MΩ min (At Room Temperature)						
ENVIRONMENT	OPERATING TEMP., HUMIDITY AND ALTITUDE	-20 to +70°C, 20 - 90%RH (Non condensing)						
	STORAGE TEMP., HUMIDITY AND ALTITUDE	-20 to +75°C, 20 - 90%RH (Non condensing)						
	VIBRATION	10 - 55Hz 19.6m/s ² (2G) 3minutes period, 60minutes each along X, Y and Z axis						
	IMPACT	196.1m/s ² (20G) 11ms, once each X, Y and Z axis						
SAFETY AND NOISE REGULATIONS	AGENCY APPROVALS	UL62368-1, EN62368-1, C-UL (equivalent to CAN/CSA-C22.2 No.62368-1), ANSI/AAMI ES60601-1, EN60601-1 3rd, C-UL (equivalent to CAN/CSA-C22.2 No.60601-1), UL508 (Optional), Complies with IEC60601-1-2 4th Ed.						
	CONDUCTED NOISE	Complies with FCC Part15 classB, VCCI-B, CISPR32-B, EN55011-B, EN55032-B						
	HARMONIC ATTENUATOR *6	Complies with IEC61000-3-2 (class A)						

SPECIFICATIONS

OTHERS	CASE SIZE/WEIGHT	89 X 41 X 152mm [3.50 X 1.61 X 5.98 inches] (without terminal block and screw) (W X H X D) / 840g max
	COOLING METHOD	Forced cooling (internal fan)

- *1 DC input safety agency approvals deleted.
- *2 The value is primary surge. The current of input surge to a built-in EMI/EMS Filter(0.2ms or less) is excluded.
- *3 Measured by 20MHz oscilloscope or Ripple-Noise meter (equivalent to KEISOKU-GIKEN:RM103). Please refer to the instruction manual 1.2.
- *4 5V output product, the maximum temperature of 40°C.
- *5 Drift is the change in DC output for an eight hours period after a half-hour warm-up at 25°C.
- *6 Please contact us about another class.
- *7 The listed options may affect the published standard specifications. Please contact us for detailed product specifications and safety approvals.
- * A sound may occur from power supply at pulse loading.

Features

- Low profile (41mm, 1.61 inch = meet 1U height)
- Universal input 85 - 264VAC
- DC input 88 - 370VDC possible
- For medical electric equipment (ANSI/AAMI ES60601-1, EN60601-1 3rd, IEC60601-1-2 4th Ed.)
- Medical Isolation Grade 2MOPP
- With AUX output 12V 0.1A (Voltage adjustable range 5 - 12V)
- Constant current function
- Output voltage can be adjusted to near 0V (the item 2.6 on Instruction Manual)
- With various alarms
- Parallel Operation / N+1 Parallel Redundancy Operation possible
- Monitoring function and various setting values can be changed by communication (the item 2.11 on Instruction Manual)
- Complies with SEMI F47 (the item 2.1 on Instruction Manual)
- UL508 approval

Block diagram

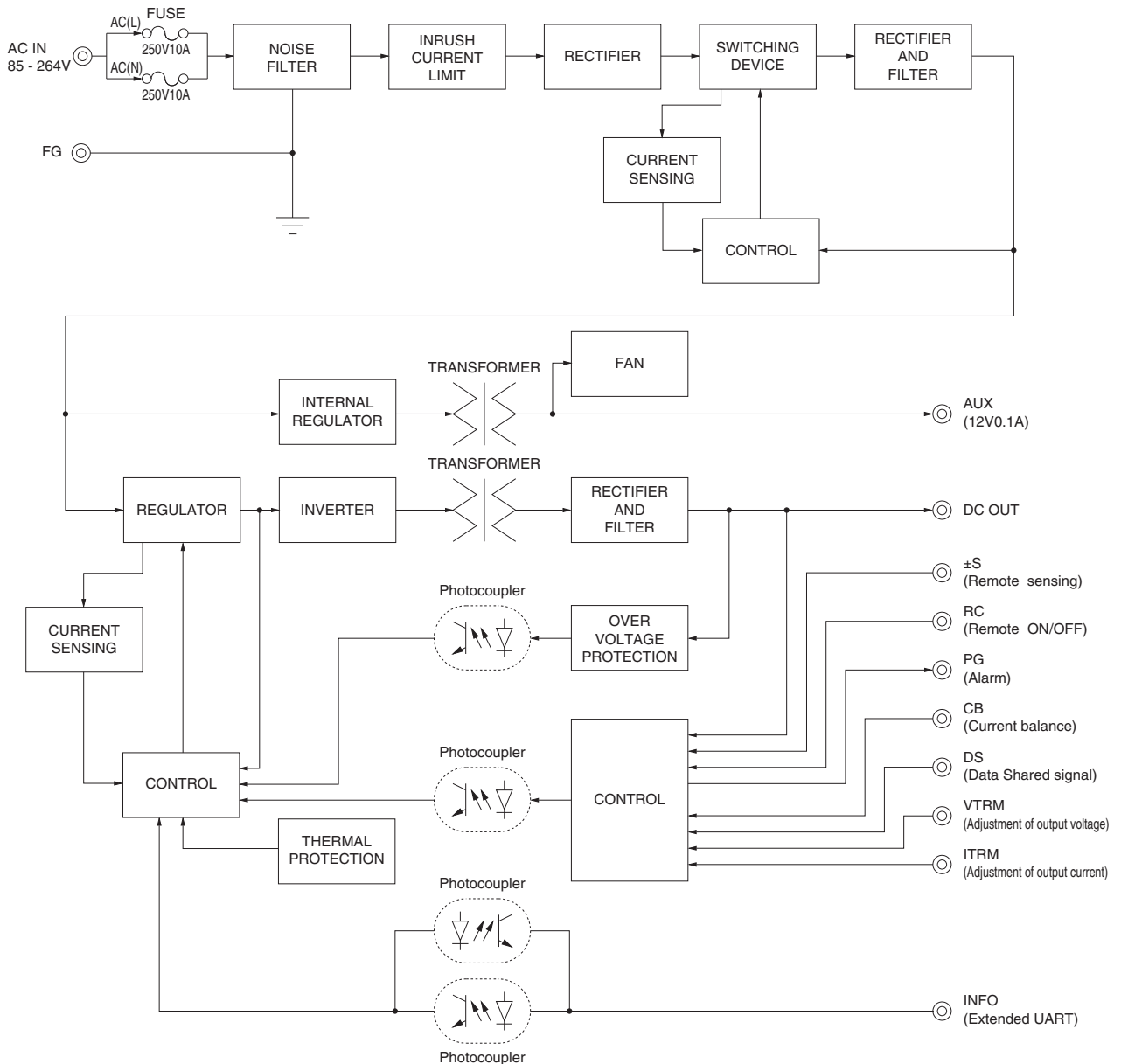

External view

<PCA300F-□ (Bus Bar Style) >

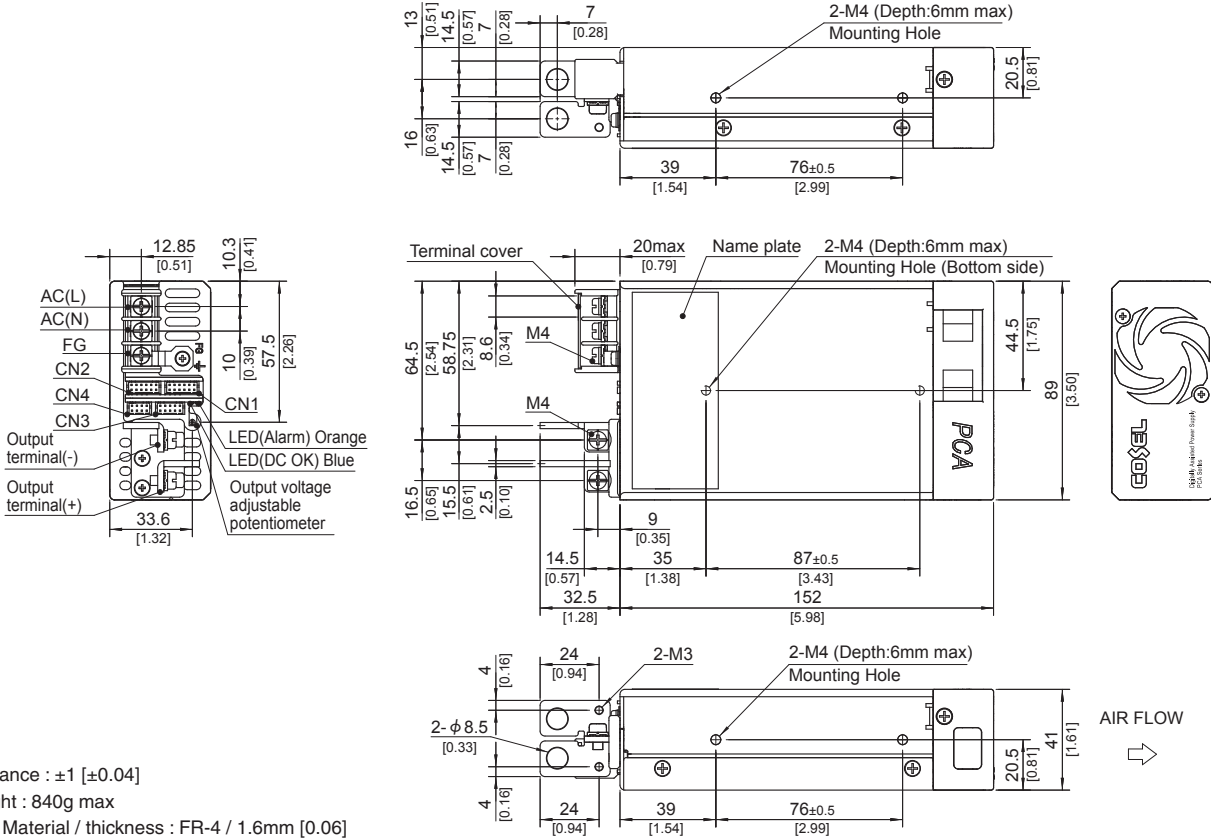

- ※ Tolerance : ±1 [±0.04]
- ※ Weight : 840g max
- ※ PCB Material / thickness : FR-4 / 1.6mm [0.06]
- ※ Chassis Material : Aluminum
- ※ Fan cover Material : PBT
- ※ Dimensions in mm, [] = inches
- ※ Mounting torque : 1.2N·m max
- ※ Input and output terminal screw tightening torque
 - M3 0.6N·m max
 - M4 1.6N·m max
- ※ Please connect safety ground to FG terminal on the unit.

External view

<PCA300F-□-T (Terminal Block Style) >

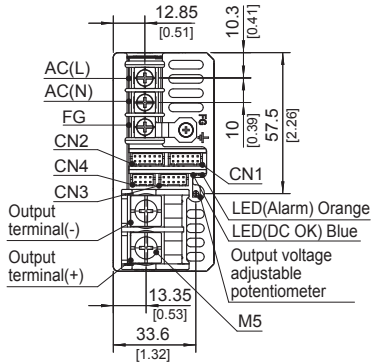

- ※ Tolerance : ±1 [±0.04]
- ※ Weight : 840g max
- ※ PCB Material / thickness : FR-4 / 1.6mm [0.06]
- ※ Chassis Material : Aluminum
- ※ Fan cover Material : PBT
- ※ Dimensions in mm, [] = inches
- ※ Mounting torque : 1.2N·m max
- ※ Input and output terminal screw tightening torque
M4 1.6N·m max
M5 2.5N·m max
- ※ Please connect safety ground to FG terminal on the unit.

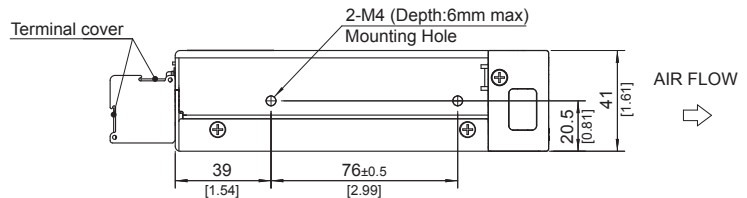
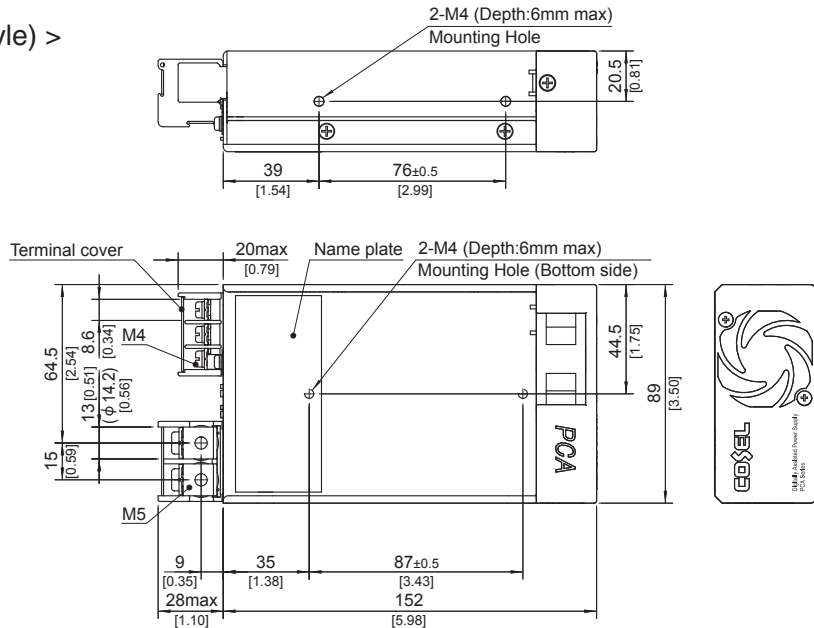

<PCA300F-□-T5 (Acquired UL508) >

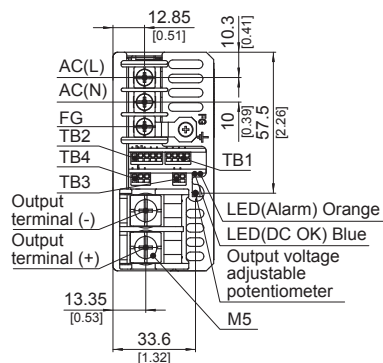

- ※ Tolerance : ±1 [±0.04]
- ※ Weight : 840g max
- ※ PCB Material / thickness : FR-4 / 1.6mm [0.06]
- ※ Chassis Material : Aluminum
- ※ Fan cover Material : PBT
- ※ Dimensions in mm, [] = inches
- ※ Mounting torque : 1.2N·m max
- ※ Input and output terminal screw tightening torque
M4 1.6N·m max
M5 2.5N·m max
- ※ Please connect safety ground to FG terminal on the unit.

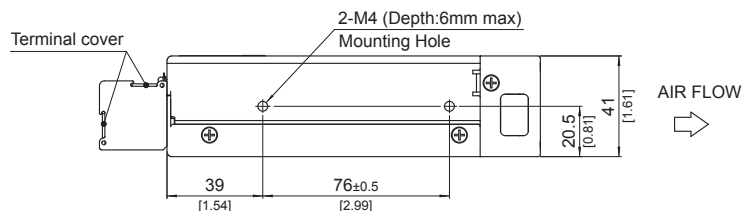
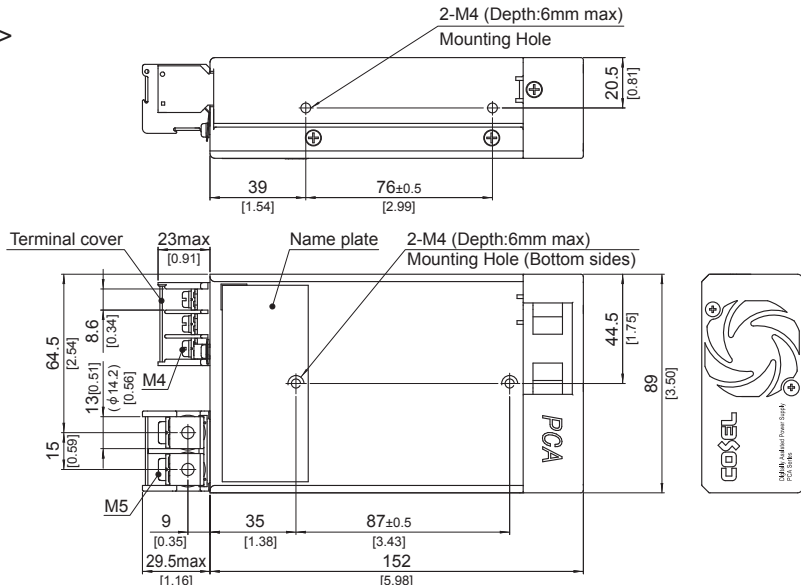

PCA600F

PC A 600 F -5 -□

① ② ③ ④ ⑤ ⑥



RoHS



2MOPP

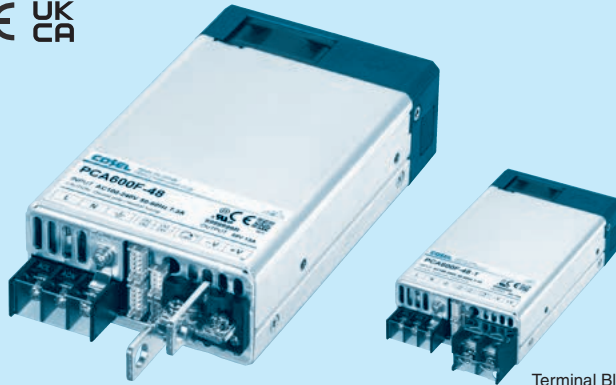

Terminal Block Style

Example recommended EMI/EMC filter
NAC-16-472



High voltage pulse noise type : NAP series
Low leakage current type : NAM series
Low profile type : EAC series

*A higher current rating EMI/EMC filter may be recommended in view of the other devices that could be connected in parallel with the power supply.

- ① Series name
- ② Single output
- ③ Output wattage
- ④ Universal input
- ⑤ Output voltage
- ⑥ Optional *7
- C : with Coating
- G : Low leakage current
- T : Terminal Block Style (Only 12V, 15V, 24V, 32V and 48V)
- I : with PMBus interface
- F2 : Reverse air exhaust type
- P3 : Master-slave Operation
- W1 : Alarm function
- T5 : UL508 (Only 12V, 15V, 24V, 32V and 48V)

For option details, refer to instruction manual 6.1.

*Make sure necessary tests will be carried out on your end equipment with the power supply installed in accordance with any required EMC/EMI regulations.

MODEL	PCA600F-5	PCA600F-12	PCA600F-15	PCA600F-24	PCA600F-32	PCA600F-48
MAX OUTPUT WATTAGE[W]	600	636	645	648	640	624
DC OUTPUT	5V 120A	12V 53A	15V 43A	24V 27A	32V 20A	48V 13A

SPECIFICATIONS

	MODEL	PCA600F-5	PCA600F-12	PCA600F-15	PCA600F-24	PCA600F-32	PCA600F-48	
INPUT	VOLTAGE	[VAC] 85 - 264 1φ (Output derating is required at less than 90V. Refer to "Derating")						
		[VDC] *1 88 - 370 (Output derating is required at less than 110V. Refer to "Derating")						
	CURRENT[A]	ACIN 100V 7.3typ						
		ACIN 230V 3.2typ						
	FREQUENCY[Hz]	50/60 (45 - 66)						
	EFFICIENCY[%]	ACIN 100V	(Io=50%) 90typ	91typ	91typ	91typ	91typ	91typ
			(Io=100%) 89typ	90typ	90typ	91typ	91typ	91typ
		ACIN 230V	(Io=50%) 92typ	92typ	92typ	93typ	93typ	93typ
			(Io=100%) 91typ	92typ	92typ	93typ	93typ	93typ
	POWER FACTOR	ACIN 100V 0.98typ (Io=100%)						
	ACIN 230V 0.95typ (Io=100%)							
INRUSH CURRENT[A]	ACIN 100V*2 20/40 typ (Io=100%) (Primary inrush current / Secondary inrush current) (More than 3 sec. to re-start)							
	ACIN 230V*2 40/40 typ (Io=100%) (Primary inrush current / Secondary inrush current) (More than 3 sec. to re-start)							
LEAKAGE CURRENT[ma]	0.5max (ACIN 240V 60Hz, Io=100%, According to IEC60601-1)							
OUTPUT	VOLTAGE[V]	5	12	15	24	32	48	
	CURRENT[A]	120	53	43	27	20	13	
	LINE REGULATION[mV]	20max	48max	60max	96max	128max	192max	
	LOAD REGULATION[mV]	40max	100max	120max	150max	150max	480max	
	RIPPLE[mVp-p]	0 to +50°C *3*4 160max	240max	240max	240max	320max	480max	
		-20 to 0°C *3 280max	320max	320max	320max	420max	640max	
	RIPPLE NOISE[mVp-p]	0 to +50°C *3*4 240max	300max	300max	300max	400max	600max	
		-20 to 0°C *3 320max	360max	360max	360max	480max	720max	
	TEMPERATURE REGULATION[mV]	0 to +50°C *4 50max	120max	150max	240max	320max	480max	
		-20 to +50°C *4 75max	180max	180max	290max	400max	600max	
	DRIFT[mV]	*5 20max	48max	60max	96max	128max	192max	
	START-UP TIME[ms]	700typ (ACIN 100/230V Io=100%)						
	HOLD-UP TIME[ms]	20typ (ACIN 230V Io=80%) / 16typ (ACIN 230V Io=100%)						
OUTPUT VOLTAGE ADJUSTMENT RANGE[V]	3.00 to 6.00	7.20 to 14.40	9.00 to 18.00	14.40 to 28.80	19.20 to 38.40	28.80 to 57.60		
OUTPUT VOLTAGE SETTING[V]	5.00 to 5.05	12.00 to 12.12	15.00 to 15.15	24.00 to 24.24	32.00 to 32.32	48.00 to 48.48		
OVERCURRENT PROTECTION	Works over 105% of rating (Recovers automatically, Hiccup overcurrent)							
OVERVOLTAGE PROTECTION[V]	6.25 to 7.00	15.00 to 16.80	18.75 to 21.00	30.00 to 33.60	40.00 to 44.80	60.00 to 67.20		
REMOTE SENSING	Provided							
REMOTE ON/OFF (RC)	Provided							
DC_OK LAMP	LED (Blue)							
ALARM LAMP	LED (Orange)							
COMMUNICATION FUNCTION	Provided (Extended UART)							
ISOLATION	INPUT-OUTPUT	AC4,000V 1minute, Cutoff current = 10mA, DC500V 50MΩ min (At Room Temperature) 2MOPP						
	INPUT-FG	AC2,000V 1minute, Cutoff current = 10mA, DC500V 50MΩ min (At Room Temperature) 1MOPP						
	OUTPUT-FG	AC500V 1minute, Cutoff current = 100mA, DC500V 50MΩ min (At Room Temperature)						
	OUTPUT - AUX · RC · PG · INFO · DS · ADDR0 · ADDR1 · ADDR2	AC500V 1minute, Cutoff current = 100mA, DC500V 50MΩ min (At Room Temperature)						
ENVIRONMENT	OPERATING TEMP., HUMIDITY AND ALTITUDE	-20 to +70°C, 20 - 90%RH (Non condensing)						
	STORAGE TEMP., HUMIDITY AND ALTITUDE	-20 to +75°C, 20 - 90%RH (Non condensing)						
	VIBRATION	10 - 55Hz 19.6m/s ² (2G) 3minutes period, 60minutes each along X, Y and Z axis						
	IMPACT	196.1m/s ² (20G) 11ms, once each X, Y and Z axis						
SAFETY AND NOISE REGULATIONS	AGENCY APPROVALS	UL62368-1, EN62368-1, C-UL (equivalent to CAN/CSA-C22.2 No.62368-1), ANSI/AAMI ES60601-1, EN60601-1 3rd, C-UL (equivalent to CAN/CSA-C22.2 No.60601-1), UL508 (Optional), Complies with IEC60601-1-2 4th Ed.						
	CONDUCTED NOISE	Complies with FCC Part15 classB, VCCI-B, CISPR32-B, EN55011-B, EN55032-B						
	HARMONIC ATTENUATOR *6	Complies with IEC61000-3-2 (class A)						

SPECIFICATIONS

OTHERS	CASE SIZE/WEIGHT	89 X 41 X 152mm [3.50 X 1.61 X 5.98 inches] (without terminal block and screw) (W X H X D) / 840g max
	COOLING METHOD	Forced cooling (internal fan)

- *1 DC input safety agency approvals deleted.
- *2 The value is primary surge. The current of input surge to a built-in EMI/EMS Filter(0.2ms or less) is excluded.
- *3 Measured by 20MHz oscilloscope or Ripple-Noise meter (equivalent to KEISOKU-GIKEN:RM103). Please refer to the instruction manual 1.2.
- *4 5V output product, the maximum temperature of 40°C.
- *5 Drift is the change in DC output for an eight hours period after a half-hour warm-up at 25°C.
- *6 Please contact us about another class.
- *7 The listed options may affect the published standard specifications. Please contact us for detailed product specifications and safety approvals.
- * A sound may occur from power supply at pulse loading.

Features

- Low profile (41mm, 1.61 inch = meet 1U height)
- Universal input 85 - 264VAC (Refer to “Derating”, when using at 85 - 90VAC)
- DC input 88 - 370VDC possible (Refer to when using at 88 - 110VDC)
- For medical electric equipment (ANSI/AAMI ES60601-1, EN60601-1 3rd, IEC60601-1-2 4th Ed.)
- Medical Isolation Grade 2MOPP
- With AUX output 12V 0.1A (Voltage adjustable range 5 - 12V)
- Constant current function
- Output voltage can be adjusted to near 0V (the item 2.6 on Instruction Manual)
- With various alarms
- Parallel Operation / N+1 Parallel Redundancy Operation possible
- Monitoring function and various setting values can be changed by communication (the item 2.11 on Instruction Manual)
- Complies with SEMI F47 (the item 2.1 on Instruction Manual)
- UL508 approval

Block diagram

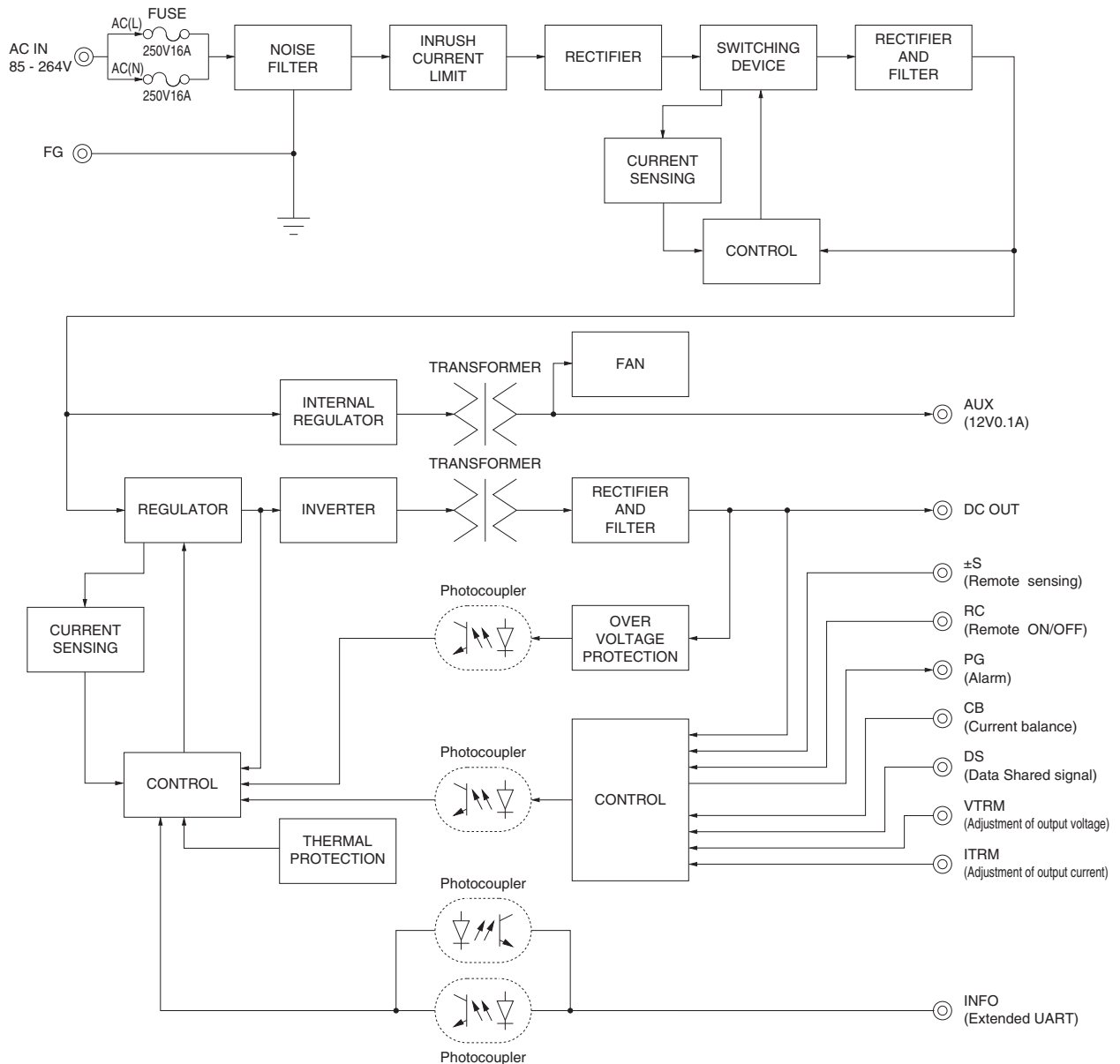

<PCA600F-□ (Bus Bar Style) >

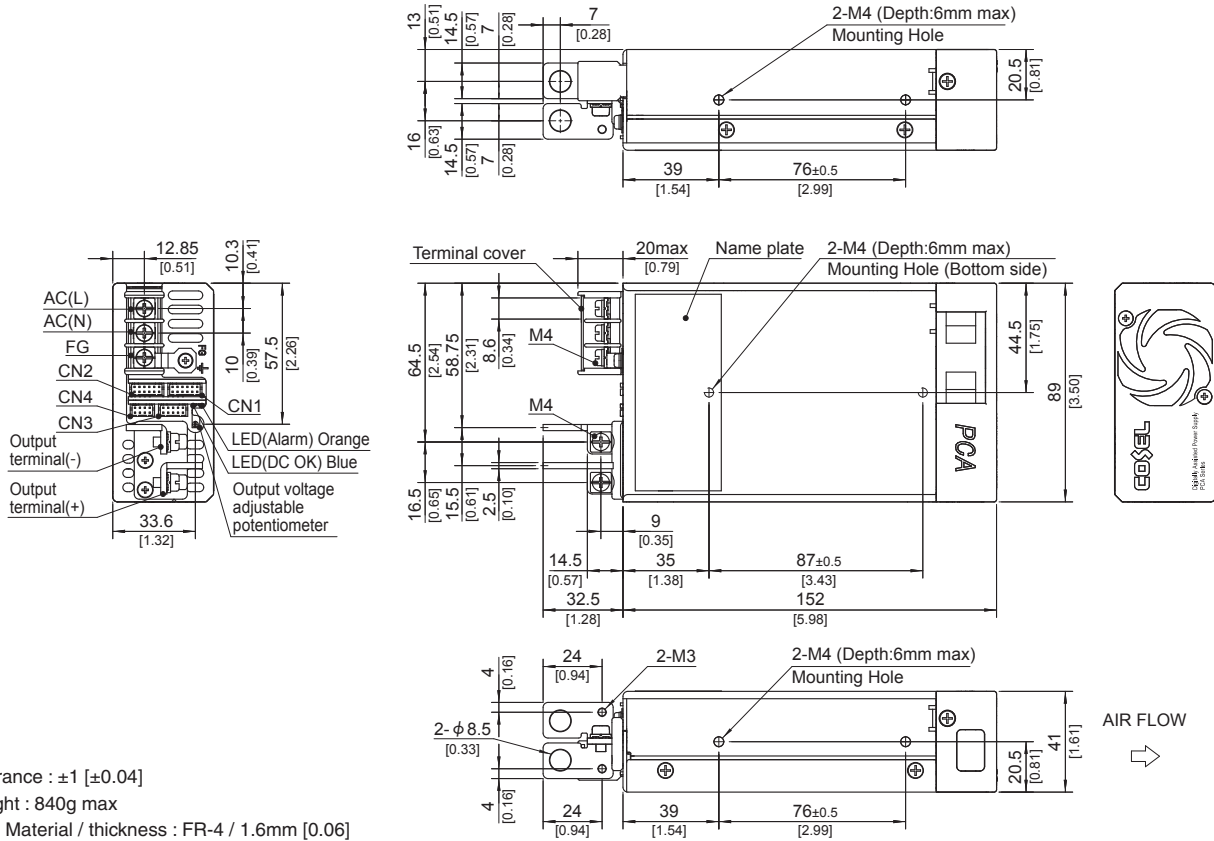

- ※ Tolerance : ±1 [±0.04]
- ※ Weight : 840g max
- ※ PCB Material / thickness : FR-4 / 1.6mm [0.06]
- ※ Chassis Material : Aluminum
- ※ Fan cover Material : PBT
- ※ Dimensions in mm, [] = inches
- ※ Mounting torque : 1.2N·m max
- ※ Input and output terminal screw tightening torque
 - M3 0.6N·m max
 - M4 1.6N·m max
- ※ Please connect safety ground to FG terminal on the unit.

External view

<PCA600F-□-T (Terminal Block Style) >

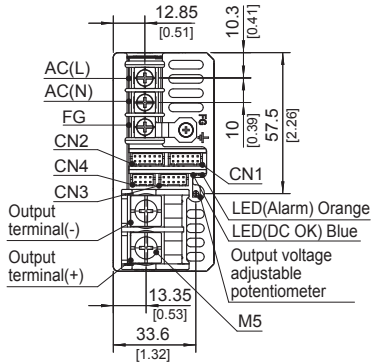

- ※ Tolerance : ±1 [±0.04]
- ※ Weight : 840g max
- ※ PCB Material / thickness : FR-4 / 1.6mm [0.06]
- ※ Chassis Material : Aluminum
- ※ Fan cover Material : PBT
- ※ Dimensions in mm, [] = inches
- ※ Mounting torque : 1.2N·m max
- ※ Input and output terminal screw tightening torque
 - M4 1.6N·m max
 - M5 2.5N·m max
- ※ Please connect safety ground to FG terminal on the unit.

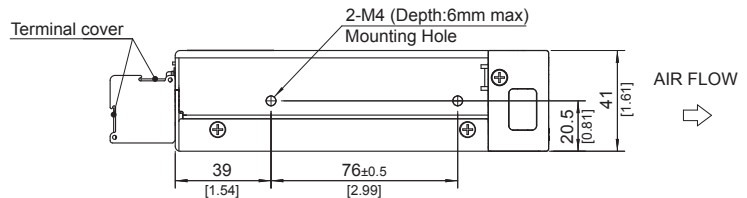
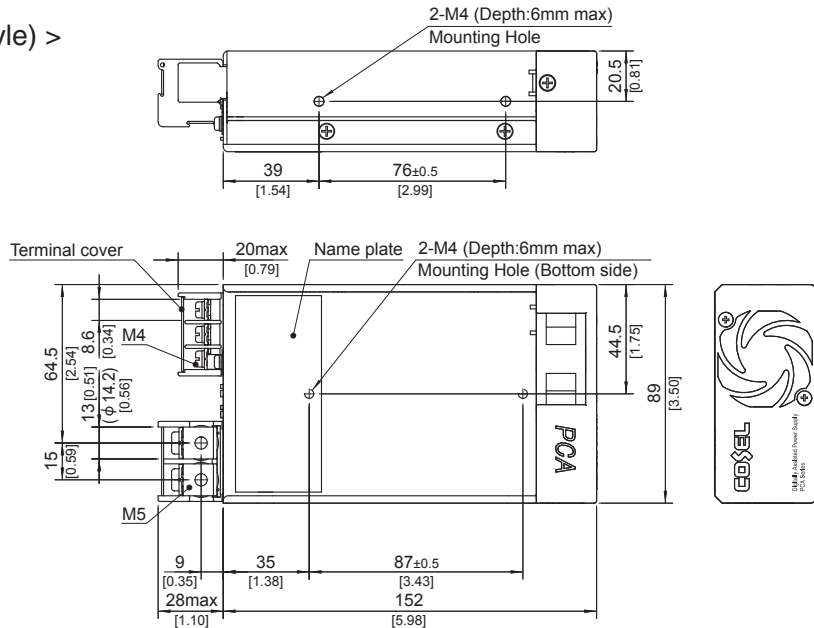

<PCA600F-□-T5 (Acquired UL508) >

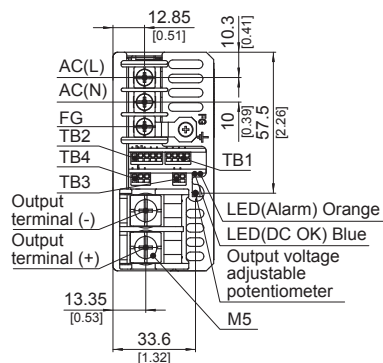

- ※ Tolerance : ±1 [±0.04]
- ※ Weight : 840g max
- ※ PCB Material / thickness : FR-4 / 1.6mm [0.06]
- ※ Chassis Material : Aluminum
- ※ Fan cover Material : PBT
- ※ Dimensions in mm, [] = inches
- ※ Mounting torque : 1.2N·m max
- ※ Input and output terminal screw tightening torque
 - M4 1.6N·m max
 - M5 2.5N·m max
- ※ Please connect safety ground to FG terminal on the unit.

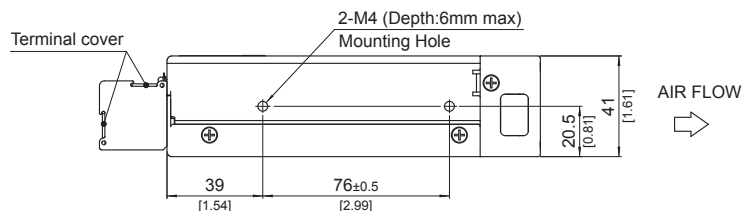
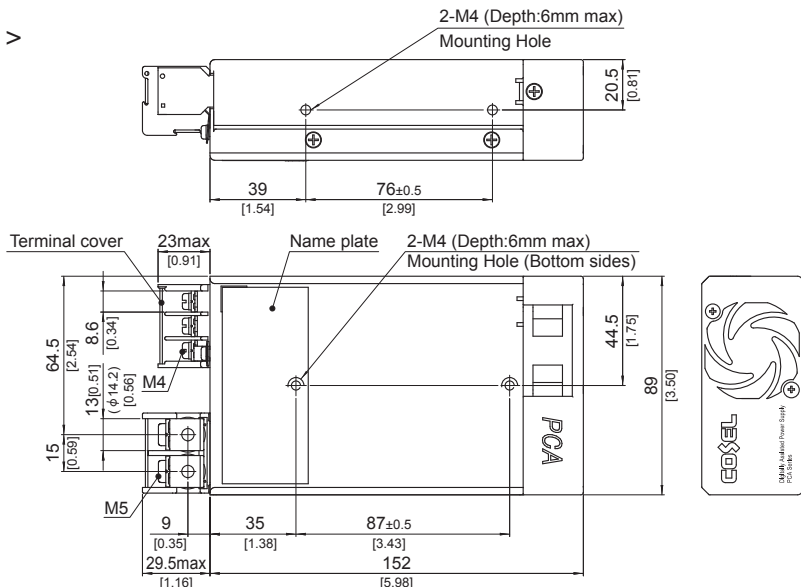

PCA1000F

PC A 1000 F -5 -□

① ② ③ ④ ⑤ ⑥

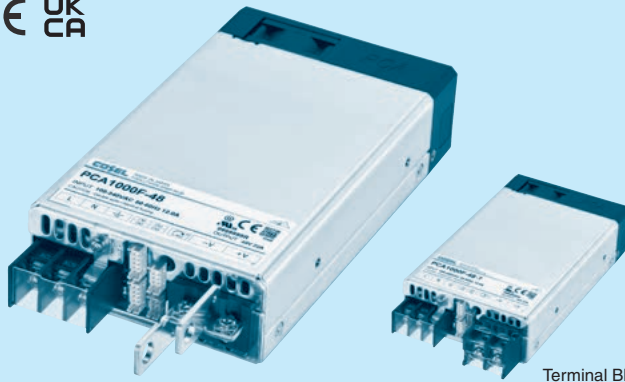

Example recommended EMI/EMC filter
NAC-20-472



High voltage pulse noise type : NAP series
Low leakage current type : NAM series
Low profile type : EAC series

* A higher current rating EMI/EMC filter may be recommended in view of the other devices that could be connected in parallel with the power supply.

- ① Series name
- ② Single output
- ③ Output wattage
- ④ Universal input
- ⑤ Output voltage
- ⑥ Optional *6
- C : with Coating
- G : Low leakage current
- T : Terminal Block Style
- I : (Only 24V, 32V and 48V)
- L : with PMBus interface
- F2 : Reverse air exhaust type
- P3 : Master-slave Operation
- W1 : Alarm function
- E1 : EMI classB
- (Only 24V, 32V and 48V)
- T5 : UL508
- (Only 24V, 32V and 48V)

For option details, refer to instruction manual 6.1.

* Make sure necessary tests will be carried out on your end equipment with the power supply installed in accordance with any required EMC/EMI regulations.

MODEL	PCA1000F-5	PCA1000F-12	PCA1000F-15	PCA1000F-24	PCA1000F-32	PCA1000F-48
MAX OUTPUT WATTAGE[W]	1000	1056	1050	1056	1056	1056
DC OUTPUT	5V 200A	12V 88A	15V 70A	24V 44A	32V 33A	48V 22A

SPECIFICATIONS

	MODEL	PCA1000F-5	PCA1000F-12	PCA1000F-15	PCA1000F-24	PCA1000F-32	PCA1000F-48	
INPUT	VOLTAGE [VAC]	85 - 264 1 φ (Output derating is required at less than 90V. Refer to "Derating")						
	CURRENT[A]	ACIN 100V	12.0typ					
		ACIN 230V	5.3typ					
	FREQUENCY[Hz]	50/60 (45 - 66)						
	EFFICIENCY[%]	ACIN 100V	(Io=50%)	90typ	91typ	91typ	91typ	91typ
			(Io=100%)	89typ	90typ	90typ	91typ	91typ
		ACIN 230V	(Io=50%)	92typ	92typ	92typ	93typ	93typ
			(Io=100%)	91typ	92typ	92typ	93typ	93typ
	POWER FACTOR	ACIN 100V	0.98typ (Io=100%)					
		ACIN 230V	0.95typ (Io=100%)					
INRUSH CURRENT[A]	ACIN 100V*1	20/40 typ (Io=100%) (Primary inrush current / Secondary inrush current) (More than 3 sec. to re-start)						
	ACIN 230V*1	40/40 typ (Io=100%) (Primary inrush current / Secondary inrush current) (More than 3 sec. to re-start)						
LEAKAGE CURRENT[ma]	0.5max (ACIN 240V 60Hz, Io=100%, According to IEC60601-1)							
OUTPUT	VOLTAGE[V]	5	12	15	24	32	48	
	CURRENT[A]	200	88	70	44	33	22	
	LINE REGULATION[mV]	20max	48max	60max	96max	128max	192max	
	LOAD REGULATION[mV]	40max	100max	120max	150max	150max	480max	
	RIPPLE[mVp-p]	0 to +50°C *2*3	160max	240max	240max	240max	320max	480max
		-20 to 0°C *2	280max	320max	320max	320max	420max	640max
	RIPPLE NOISE[mVp-p]	0 to +50°C *2*3	240max	300max	300max	300max	400max	600max
		-20 to 0°C *2	320max	360max	360max	360max	480max	720max
	TEMPERATURE REGULATION[mV]	0 to +50°C *3	50max	120max	150max	240max	320max	480max
		-20 to +50°C *3	75max	180max	180max	290max	400max	600max
DRIFT[mV]	*4	20max	48max	60max	96max	128max	192max	
START-UP TIME[ms]	700typ (ACIN 100/230V Io=100%)							
HOLD-UP TIME[ms]	20typ (ACIN 230V Io=80%) / 16typ (ACIN 230V Io=100%)							
OUTPUT VOLTAGE ADJUSTMENT RANGE[V]	3.00 to 6.00	7.20 to 14.40	9.00 to 18.00	14.40 to 28.80	19.20 to 38.40	28.80 to 57.60		
OUTPUT VOLTAGE SETTING[V]	5.00 to 5.05	12.00 to 12.12	15.00 to 15.15	24.00 to 24.24	32.00 to 32.32	48.00 to 48.48		
PROTECTION CIRCUIT AND OTHERS	OVERCURRENT PROTECTION	Works over 105% of rating (Recovers automatically, Hiccup overcurrent)						
	OVERVOLTAGE PROTECTION[V]	6.25 to 7.00	15.00 to 16.80	18.75 to 21.00	30.00 to 33.60	40.00 to 44.80	60.00 to 67.20	
	REMOTE SENSING	Provided						
	REMOTE ON/OFF (RC)	Provided						
	DC_OK LAMP	LED (Blue)						
	ALARM LAMP	LED (Orange)						
COMMUNICATION FUNCTION	Provided (Extended UART)							
ISOLATION	INPUT-OUTPUT	AC4,000V 1minute, Cutoff current = 10mA, DC500V 50MΩ min (At Room Temperature) 2MOPP						
	INPUT-FG	AC2,000V 1minute, Cutoff current = 10mA, DC500V 50MΩ min (At Room Temperature) 1MOPP						
	OUTPUT-FG	AC500V 1minute, Cutoff current = 100mA, DC500V 50MΩ min (At Room Temperature)						
	OUTPUT-AUX-RC-PG-INFO-DS-ADDR0-ADDR1-ADDR2	AC500V 1minute, Cutoff current = 100mA, DC500V 50MΩ min (At Room Temperature)						
ENVIRONMENT	OPERATING TEMP., HUMIDITY AND ALTITUDE	-20 to +70°C, 20 - 90%RH (Non condensing)						
	STORAGE TEMP., HUMIDITY AND ALTITUDE	-20 to +75°C, 20 - 90%RH (Non condensing)						
	VIBRATION	10 - 55Hz 19.6m/s ² (2G) 3minutes period, 60minutes each along X, Y and Z axis						
	IMPACT	196.1m/s ² (20G) 11ms, once each X, Y and Z axis						
SAFETY AND NOISE REGULATIONS	AGENCY APPROVALS	UL62368-1, EN62368-1, C-UL (equivalent to CAN/CSA-C22.2 No.62368-1), ANSI/AAMI ES60601-1, EN60601-1 3rd, C-UL (equivalent to CAN/CSA-C22.2 No.60601-1), UL508 (Optional), Complies with IEC60601-1-2 4th Ed.						
	CONDUCTED NOISE	Complies with FCC Part15 classA, VCCI-A, CISPR32-A, EN55011-A, EN55032-A						
	HARMONIC ATTENUATOR *5	Complies with IEC61000-3-2 (class A)						

SPECIFICATIONS

OTHERS	CASE SIZE/WEIGHT	102×41×178mm [4.02×1.61×7.01 inches] (without terminal block and screw) (W×H×D) / 1.2kg max
	COOLING METHOD	Forced cooling (internal fan)

- *1 The value is primary surge. The current of input surge to a built-in EMI/EMS Filter(0.2ms or less) is excluded.
- *2 Measured by 20MHz oscilloscope or Ripple-Noise meter (equivalent to KEISOKU-GIKEN:RM103). Please refer to the instruction manual 1.2.
- *3 5V, 12V, 15V output product, the maximum temperature of 40°C.
- *4 Drift is the change in DC output for an eight hours period after a half-hour warm-up at 25°C.
- *5 Please contact us about another class.
- *6 The listed options may affect the published standard specifications. Please contact us for detailed product specifications and safety approvals.
- * A sound may occur from power supply at pulse loading.

Features

- Low profile (41mm, 1.61 inch = meet 1U height)
- Universal input 85 - 264VAC (Refer to “Derating”, when using at 85 - 90VAC)
- For medical electric equipment (ANSI/AAMI ES60601-1, EN60601-1 3rd, IEC60601-1-2 4th Ed.)
- Medical Isolation Grade 2MOPP
- With AUX output 12V 0.1A (Voltage adjustable range 5 - 12V)
- Constant current function
- Output voltage can be adjusted to near 0V (the item 2.6 on Instruction Manual)
- With various alarms
- Parallel Operation / N+1 Parallel Redundancy Operation possible
- Monitoring function and various setting values can be changed by communication (the item 2.11 on Instruction Manual)
- Complies with SEMI F47 (the item 2.1 on Instruction Manual)
- UL508 approval

Block diagram

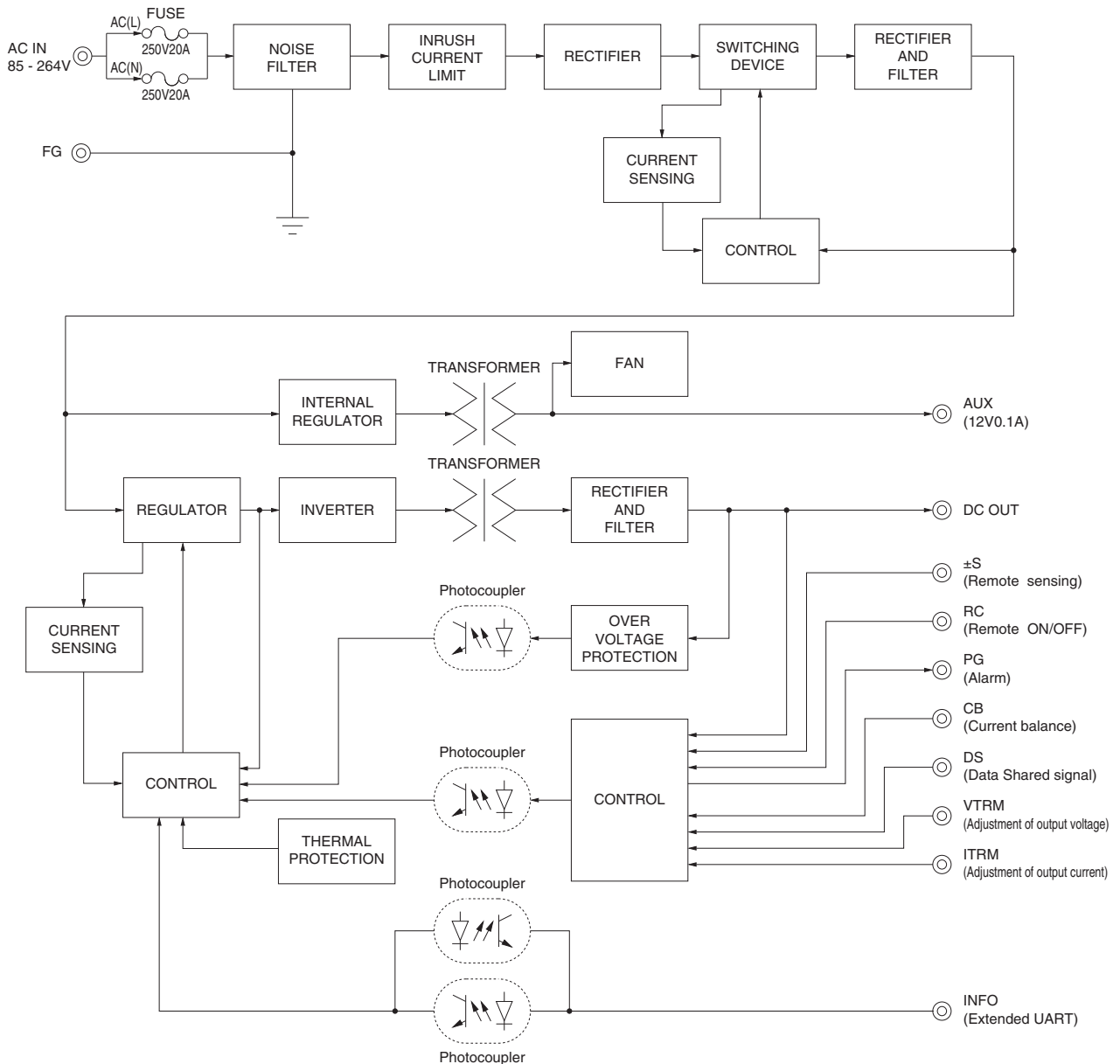

<PCA1000F-□ (Bus Bar Style) >

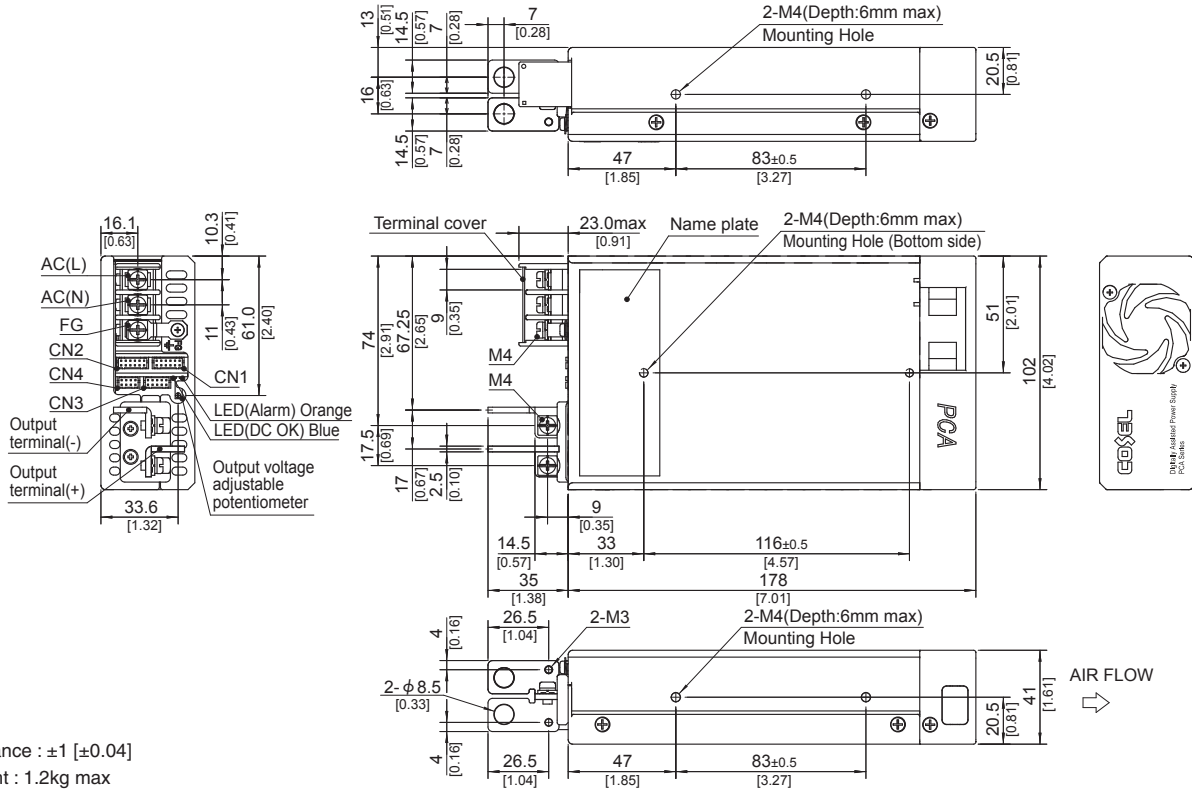

- ※ Tolerance : ±1 [±0.04]
- ※ Weight : 1.2kg max
- ※ PCB Material / thickness : FR-4 / 1.6mm [0.06]
- ※ Chassis Material : Aluminum
- ※ Fan cover Material : PBT
- ※ Dimensions in mm, [] = inches
- ※ Mounting torque : 1.2N·m max
- ※ Input and output terminal screw tightening torque
 - M3 0.6N·m max
 - M4 1.6N·m max
- ※ Please connect safety ground to FG terminal on the unit.

External view

<PCA1000F-□-T (Terminal Block Style) >

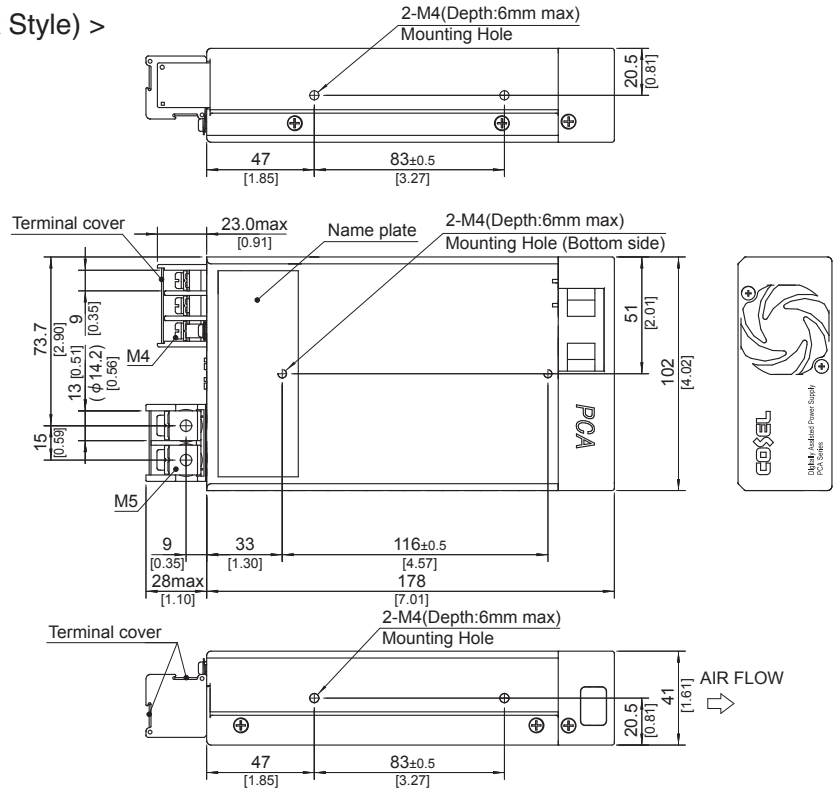
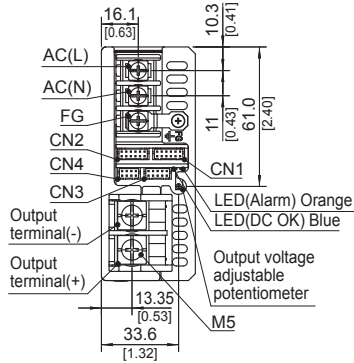

- ※ Tolerance : ±1 [±0.04]
- ※ Weight : 1.2kg max
- ※ PCB Material / thickness : FR-4 / 1.6mm [0.06]
- ※ Chassis Material : Aluminum
- ※ Fan cover Material : PBT
- ※ Dimensions in mm, [] = inches
- ※ Mounting torque : 1.2N·m max
- ※ Input and output terminal screw tightening torque
 - M4 1.6N·m max
 - M5 2.5N·m max
- ※ Please connect safety ground to FG terminal on the unit.

<PCA1000F-□-T5 (Acquired UL508) >

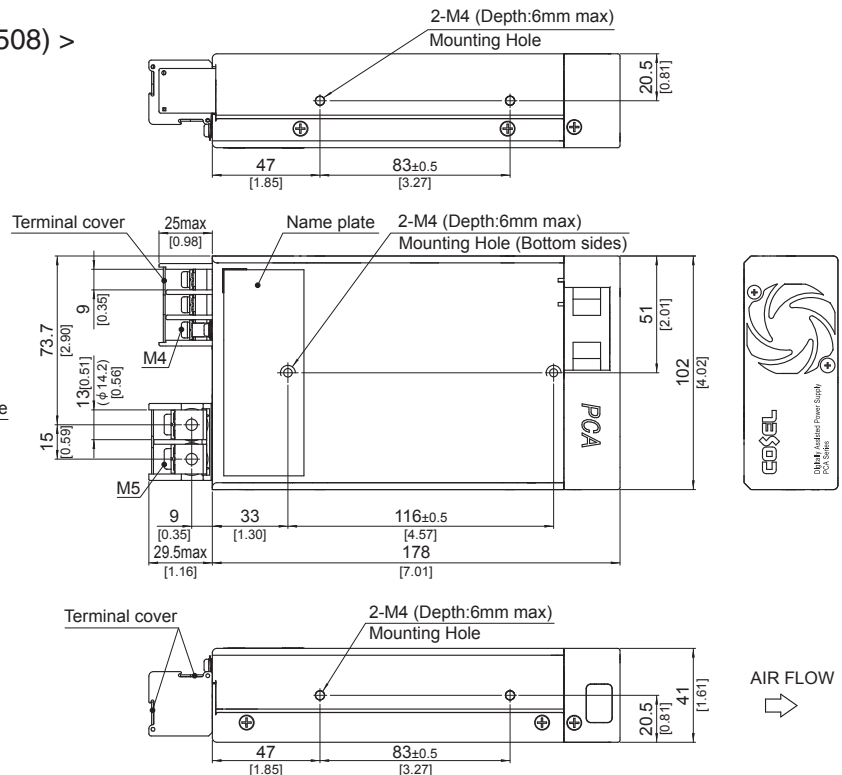
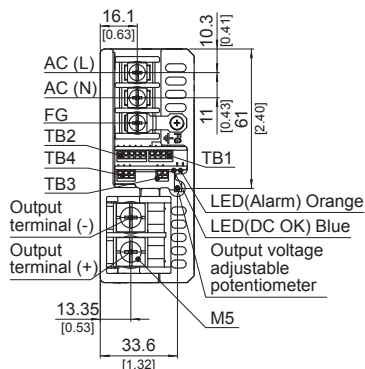

- ※ Tolerance : ±1 [±0.04]
- ※ Weight : 1.2kg max
- ※ PCB Material / thickness : FR-4 / 1.6mm [0.06]
- ※ Chassis Material : Aluminum
- ※ Fan cover Material : PBT
- ※ Dimensions in mm, [] = inches
- ※ Mounting torque : 1.2N·m max
- ※ Input and output terminal screw tightening torque
 - M4 1.6N·m max
 - M5 2.5N·m max
- ※ Please connect safety ground to FG terminal on the unit.

PCA1500F

PC A 1500 F -5 -□

① ② ③ ④ ⑤ ⑥



RoHS



2MOPP



Example recommended EMI/EMC filter
NAC-30-472



High voltage pulse noise type : NAP series
Low leakage current type : NAM series
Low profile type : EAC series

*A higher current rating EMI/EMC filter may be recommended in view of the other devices that could be connected in parallel with the power supply.

- ① Series name
- ② Single output
- ③ Output wattage
- ④ Universal input
- ⑤ Output voltage
- ⑥ Optional *6
- C : with Coating
- G : Low leakage current
- L : with PMBus interface
- F2 : Reverse air exhaust type
- P3 : Master-slave Operation
- W1 : Alarm function

For option details, refer to instruction manual 6.1.

*Make sure necessary tests will be carried out on your end equipment with the power supply installed in accordance with any required EMC/EMI regulations.

MODEL		PCA1500F-5	PCA1500F-12	PCA1500F-15	PCA1500F-24	PCA1500F-32	PCA1500F-48
MAX OUTPUT WATTAGE[W]	ACIN 100V/230V	1500/1500	1500/1500	1500/1500	1560/1680	1504/1664	1536/1680
DC OUTPUT	ACIN 100V/230V	5V 300A/300A	12V 125A/125A	15V 100A/100A	24V 65A/70A	32V 47A/52A	48V 32A/35A

SPECIFICATIONS

	MODEL	PCA1500F-5	PCA1500F-12	PCA1500F-15	PCA1500F-24	PCA1500F-32	PCA1500F-48	
INPUT	VOLTAGE	[VAC] 85 - 264 1 φ (Output derating is required at less than 95V. Refer to "Derating")						
	CURRENT[A]	ACIN 100V	18typ					
		ACIN 230V	7.8typ				8.5typ	
	FREQUENCY[Hz]	50/60 (45 - 66)						
	EFFICIENCY[%]	ACIN 100V	(Io=50%)	90typ	91typ	91typ	91typ	91typ
			(Io=100%)	88typ	90typ	90typ	91typ	91typ
		ACIN 230V	(Io=50%)	92typ	92typ	92typ	93typ	93typ
			(Io=100%)	91typ	92typ	92typ	93typ	93typ
	POWER FACTOR	ACIN 100V	0.98typ (Io=100%)					
		ACIN 230V	0.95typ (Io=100%)					
INRUSH CURRENT[A]	ACIN 100V*1	20/40 typ (Io=100%) (Primary inrush current / Secondary inrush current) (More than 10 sec. to re-start)						
	ACIN 230V*1	40/40 typ (Io=100%) (Primary inrush current / Secondary inrush current) (More than 10 sec. to re-start)						
LEAKAGE CURRENT[mA]	0.5max (ACIN 240V 60Hz, Io=100%, According to IEC60601-1)							
OUTPUT	VOLTAGE[V]	5	12	15	24	32	48	
	CURRENT[A]	ACIN 100V/230V	300/300	125/125	100/100	65/70	47/52	32/35
	LINE REGULATION[mV]	20max						
	LOAD REGULATION[mV]	40max						
	RIPPLE[mVp-p]	0 to +50°C *2*3	160max	240max	240max	240max	320max	480max
		-20 to 0°C *2	280max	320max	320max	320max	420max	640max
	RIPPLE NOISE[mVp-p]	0 to +50°C *2*3	240max	300max	300max	300max	400max	600max
		-20 to 0°C *2	320max	360max	360max	360max	480max	720max
	TEMPERATURE REGULATION[mV]	0 to +50°C *3	50max	120max	150max	240max	320max	480max
		-20 to +50°C *3	75max	180max	180max	290max	400max	600max
DRIFT[mV]	*4	20max	48max	60max	96max	128max	192max	
START-UP TIME[ms]	700typ (ACIN 100/230V Io=100%)							
HOLD-UP TIME[ms]	20typ (ACIN 230V Io=80%) / 16typ (ACIN 230V Io=100%)							
OUTPUT VOLTAGE ADJUSTMENT RANGE[V]	3.00 to 6.00		7.20 to 14.40		9.00 to 18.00		14.40 to 28.80	
OUTPUT VOLTAGE SETTING[V]	5.00 to 5.05		12.00 to 12.12		15.00 to 15.15		24.00 to 24.24	
PROTECTION CIRCUIT AND OTHERS	OVERCURRENT PROTECTION	Works over 105% of rating (Recovers automatically, Hiccup overcurrent)						
	OVERVOLTAGE PROTECTION[V]	6.25 to 7.00	15.00 to 16.80	18.75 to 21.00	30.00 to 33.60	40.00 to 44.80	60.00 to 67.20	
	REMOTE SENSING	Provided						
	REMOTE ON/OFF (RC)	Provided						
	DC_OK LAMP	LED (Blue)						
	ALARM LAMP	LED (Orange)						
COMMUNICATION FUNCTION	Provided (Extended UART)							
ISOLATION	INPUT-OUTPUT	AC4,000V 1minute, Cutoff current = 10mA, DC500V 50MΩ min (At Room Temperature) 2MOPP						
	INPUT-FG	AC2,000V 1minute, Cutoff current = 10mA, DC500V 50MΩ min (At Room Temperature) 1MOPP						
	OUTPUT-FG	AC500V 1minute, Cutoff current = 100mA, DC500V 50MΩ min (At Room Temperature)						
ENVIRONMENT	OPERATING TEMP., HUMIDITY AND ALTITUDE	AC500V 1minute, Cutoff current = 100mA, DC500V 50MΩ min (At Room Temperature)						
SAFETY AND NOISE REGULATIONS	AGENCY APPROVALS	UL62368-1, EN62368-1, C-UL (equivalent to CAN/CSA-C22.2 No.62368-1), ANSI/AAMI ES60601-1, EN60601-1 3rd, C-UL (equivalent to CAN/CSA-C22.2 No.60601-1), Complies with IEC60601-1-2 4th Ed.						
	CONDUCTED NOISE	Complies with FCC Part15 classA, VCCI-A, CISPR11-A, CISPR32-A, EN55011-A, EN55032-A						
	HARMONIC ATTENUATOR *5	Complies with IEC61000-3-2 (class A)						

SPECIFICATIONS

OTHERS	CASE SIZE/WEIGHT	140×41×203mm [5.52×1.61×7.99 inches] (without terminal block and screw) (W×H×D) / 2.0kg max
	COOLING METHOD	Forced cooling (internal fan)

- *1 The value is primary surge. The current of input surge to a built-in EMI/EMS Filter(0.2ms or less) is excluded.
- *2 Measured by 20MHz oscilloscope or Ripple-Noise meter (equivalent to KEISOKU-GIKEN:RM103). Please refer to the instruction manual 1.2.
- *3 5V, 12V, 15V output product, the maximum temperature of 40°C.
- *4 Drift is the change in DC output for an eight hours period after a half-hour warm-up at 25°C.
- *5 Please contact us about another class.
- *6 The listed options may affect the published standard specifications. Please contact us for detailed product specifications and safety approvals.
- * A sound may occur from power supply at pulse loading.

Features

- Low profile (41mm, 1.61 inch = meet 1U height)
- Universal input 85 - 264VAC (Refer to “Derating”, when using at 85 - 95VAC)
- For medical electric equipment (ANSI/AAMI ES60601-1, EN60601-1 3rd, IEC60601-1-2 4th Ed.)
- Medical Isolation Grade 2MOPP
- With AUX output 12V 0.1A (Voltage adjustable range 5 - 12V)
- Constant current function
- Output voltage can be adjusted to near 0V (Refer to the item 2.6 on Instruction Manual.)
- With various alarms
- Parallel Operation / N+1 Parallel Redundancy Operation available
- Monitoring function and various setting values can be changed by communication (Refer to the item 2.11 on Instruction Manual.)
- Complies with SEMI F47 (Refer to the item 2.1 on Instruction Manual.)

Block diagram

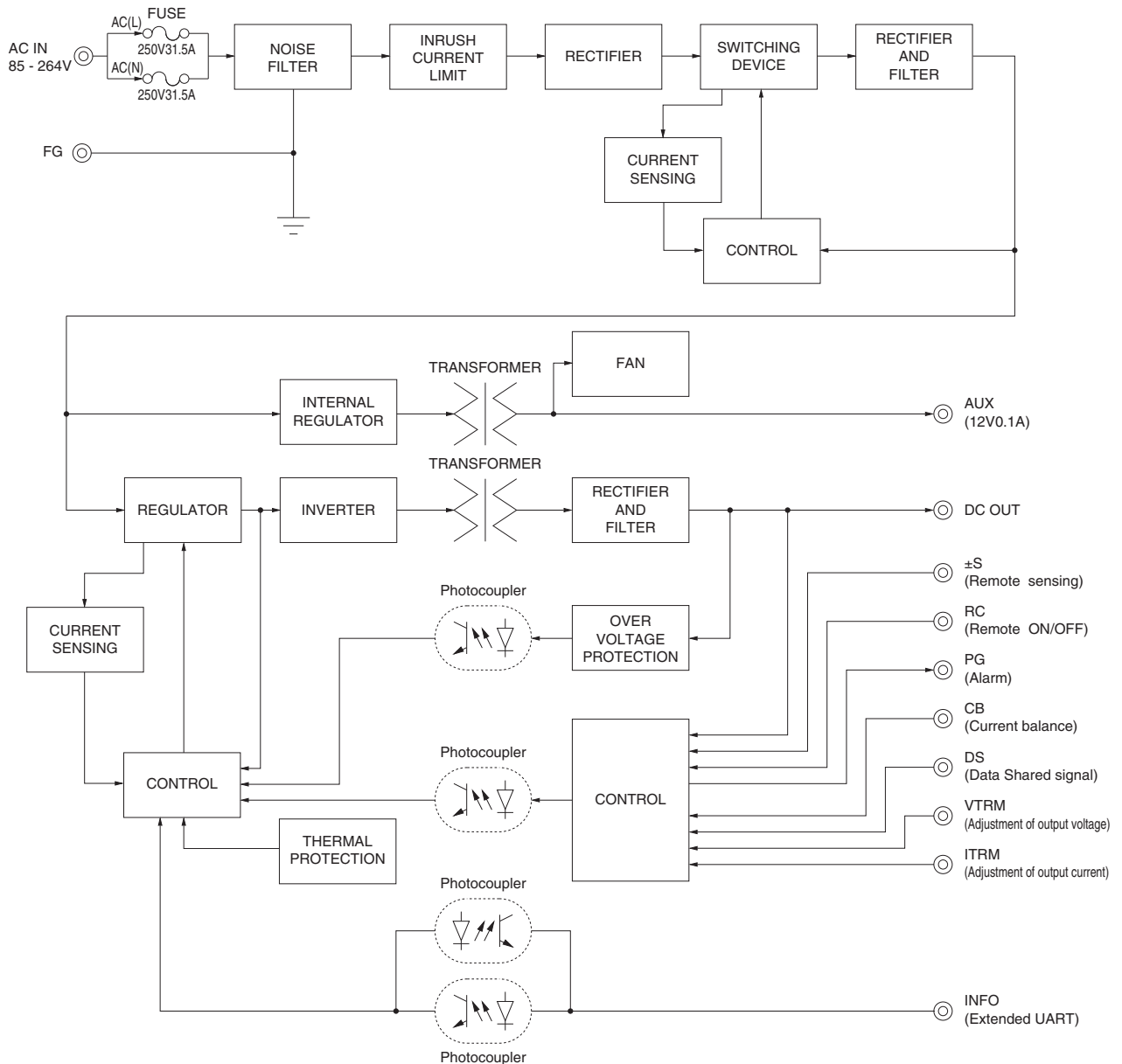

External view

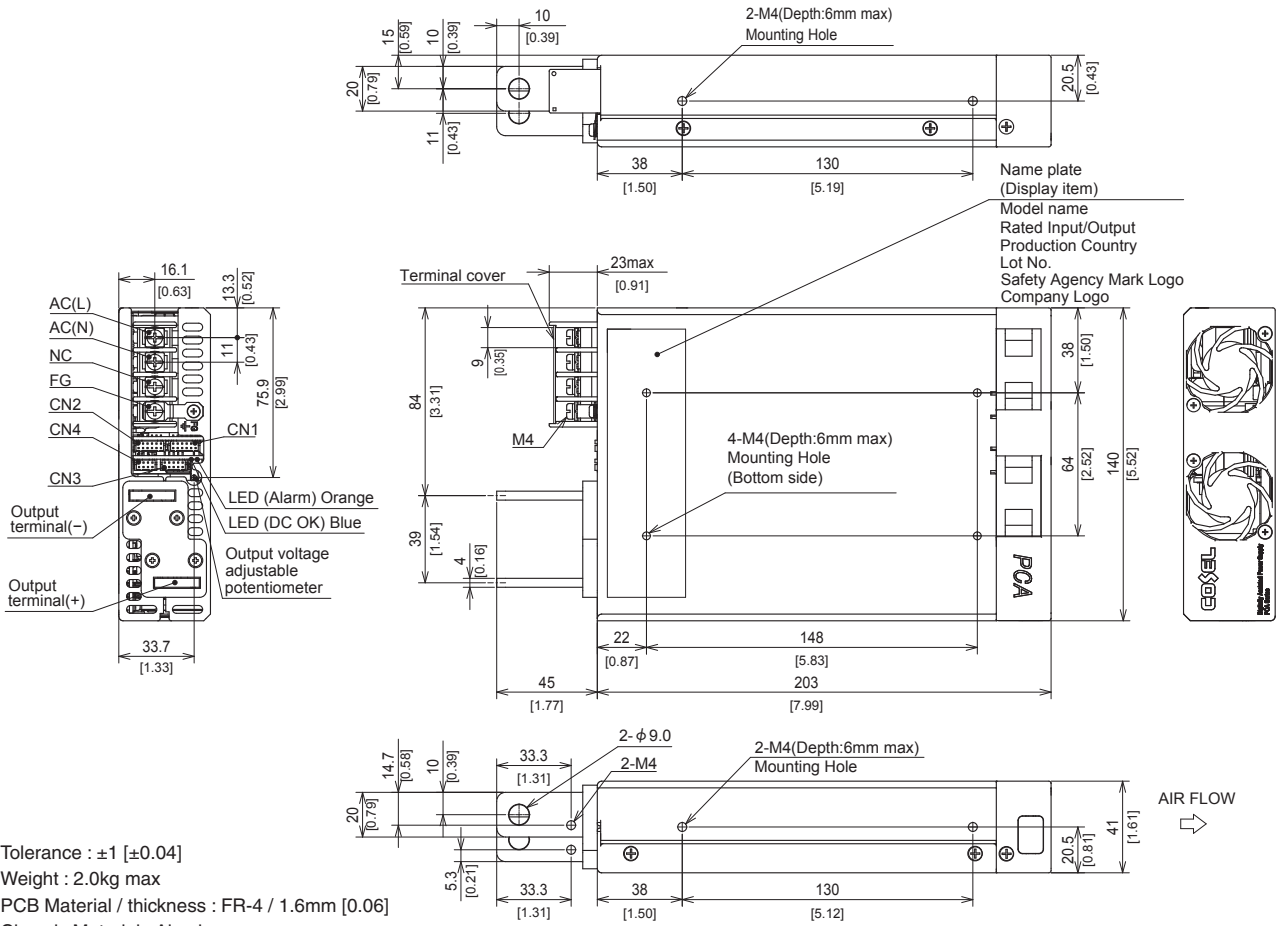

- ※ Tolerance : ±1 [±0.04]
- ※ Weight : 2.0kg max
- ※ PCB Material / thickness : FR-4 / 1.6mm [0.06]
- ※ Chassis Material : Aluminum
- ※ Fan cover Material : PBT
- ※ Dimensions in mm, [] = inches
- ※ Mounting torque : 1.2N·m max
- ※ Input and output terminal screw tightening torque
 - M3 0.6N·m max
 - M4 1.6N·m max
- ※ Please connect safety ground to FG terminal on the unit.

Terminal Blocks

● PCA300F, PCA600F

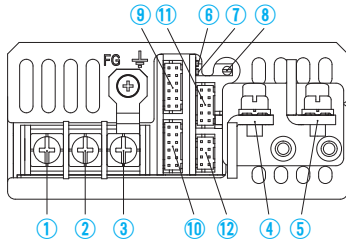

● PCA1000F

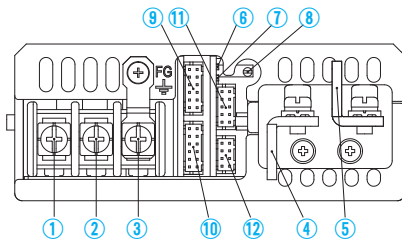

● PCA1500F

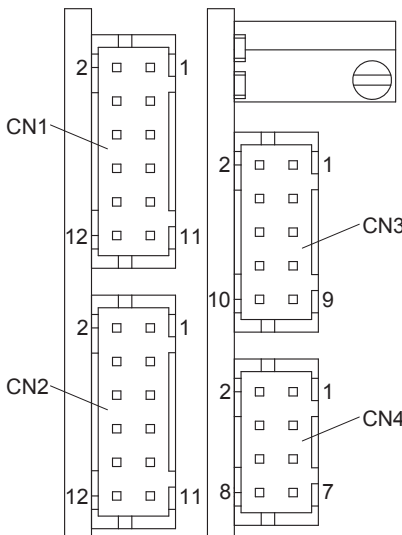
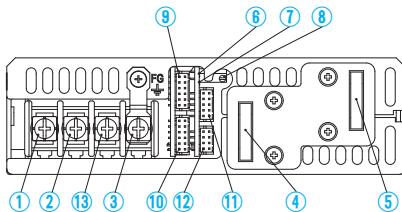

Connector pin numbers

- ①AC (L) } Input Terminals 85 - 264VAC 1 φ 45 - 66Hz
- ②AC (N) } (M4) 88 - 370VDC (Excluding PCA1000F PCA1500F)
- ③Frame ground (M4)
- ④-Output
- ⑤+Output
- ⑥LED for fault condition detection (ALARM) Color : Orange
- ⑦LED for output voltage confirmation (DC_OK) Color : Blue
- ⑧Output voltage adjustable potentiometer
- ⑨CN1
- ⑩CN2
- ⑪CN3
- ⑫CN4
- ⑬N.C.

Pin Configuration and Functions of CN1, CN2

Pin No.	Function	Ground level
1	+S +Remote sensing	COM
2	N.C. No connection	-
3	N.C. No connection	-
4	-S -Remote sensing	COM
5	VTRM Adjustment of output voltage	COM
6	COM Common ground (for signal)	COM
7	INFO Extended UART signal	SGND
8	CB Current Balance	COM
9	DS Data Shared signal	SGND
10	SGND Signal ground	SGND
11	RC2 Remote ON/OFF	RCG
12	RCG Remote ON/OFF ground	RCG

* Each terminal of CN1 and CN2 are connected inside the power supply.

Pin Configuration and Functions of CN3

Pin No.	Function	Ground level
1	AUX Auxiliary output	AUXG
2	AUXG Auxiliary output ground	AUXG
3	RC1 Remote ON/OFF	AUXG
4	AUXG Auxiliary output ground	AUXG
5	PG Alarm	PGG
6	PGG Alarm ground	PGG
7	ITRM Adjustment of output current	COM
8	COM Common ground (for signal)	COM
9	VTRM_EN Enable Vtrm	COM
10	SLV_EN Enable Slave mode *1	COM

Pin Configuration and Functions of CN4

Pin No.	Function	Ground level
1	SDA Serial data *2	SGND
2	SGND Signal ground	SGND
3	SCL Serial clock *2	SGND
4	SMBA SMBAlert *2	SGND
5	ADDR0 Address bit 0	SGND
6	ADDR1 Address bit 1	SGND
7	ADDR2 Address bit 2	SGND
8	SGND Signal ground	SGND

Matching connectors and terminals

Connector	Housing	Terminal	Mfr.
CN1 CN2	S12B-PHDS PHDR-12VS	Reel : SPHD-002T-P0.5 Loose : BPHD-001T-P0.5 *3 BPHD-002T-P0.5 *3	J.S.T
CN3	S10B-PHDS PHDR-10VS		
CN4	S8B-PHDS PHDR-8VS		

*1 For -P3 option.

*2 For -I option.

*3 The manufacturer prepares only the ratchet hand.

Assembling and Installation Method

■ Please observe the mounting screw length in right figure to obtain enough isolation between screws and internal components.

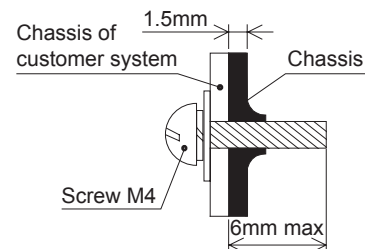

Assembling and Installation Method

- Please do not block built-in fans and ventilation holes. When the power supply is mounted by screws, please consider its weight and set it in place. (Please see below.)
- Please avoid installing the power supply by only one narrow side like the Fig.(c). In that case, another narrow side or the wide side should be also used to install as shown in Fig.(d), (e), and (f).
- If power supplies are used in a dusty environment, it might cause a failure. Please consider taking such countermeasures as installing an air filter near the suction area of the system to prevent a failure.

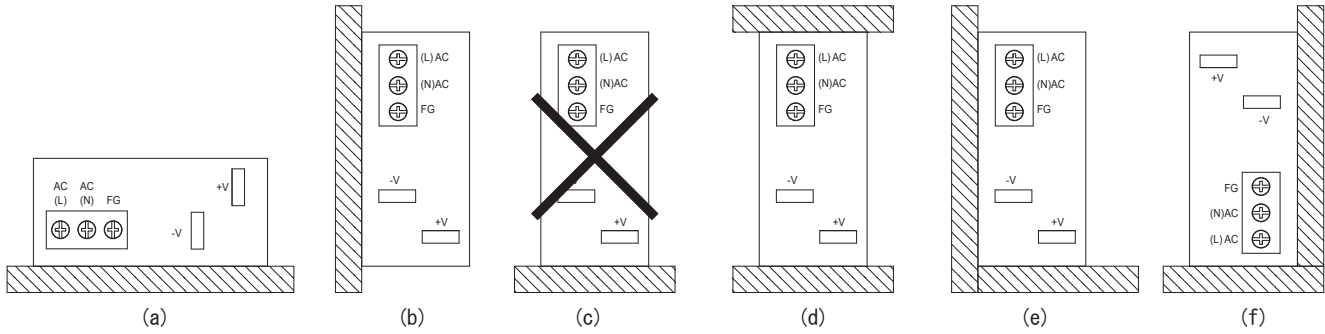

Derating

Input voltage Derating curve

● PCA600F

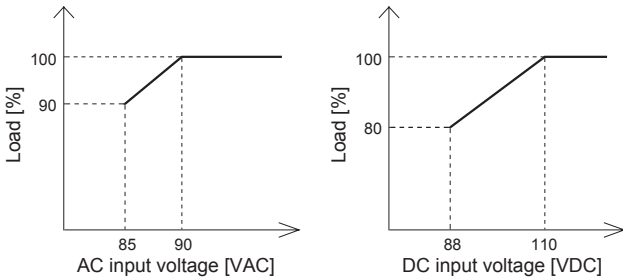

● PCA1000F

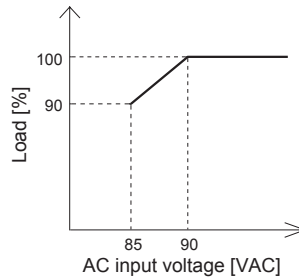

● PCA1500F

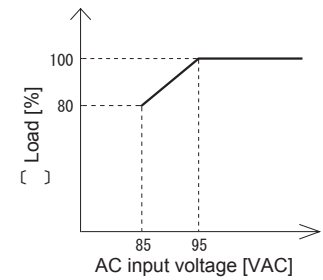

● PCA300F-5

Ambient Temperature Derating Curve

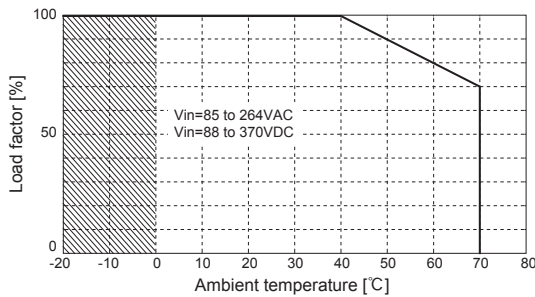

● PCA300F-12, -15, -24, -32, -48

Ambient Temperature Derating Curve

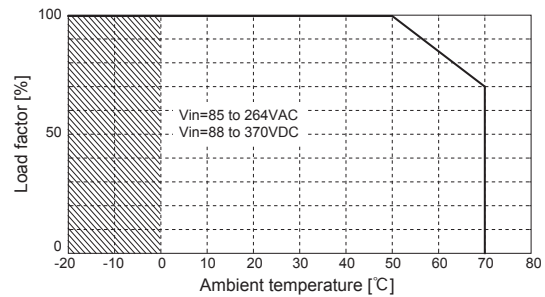

● PCA600F-5

Ambient Temperature Derating Curve

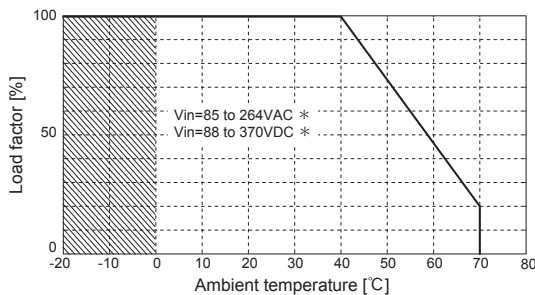

*With derating due to input voltage

● PCA600F-12, -15, -24, -32, -48

Ambient Temperature Derating Curve

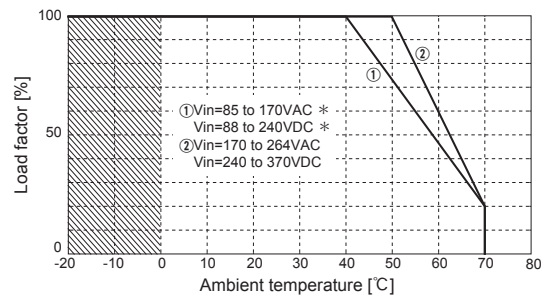

*With derating due to input voltage

Derating

● PCA1000F-5, -12, -15
Ambient Temperature Derating Curve

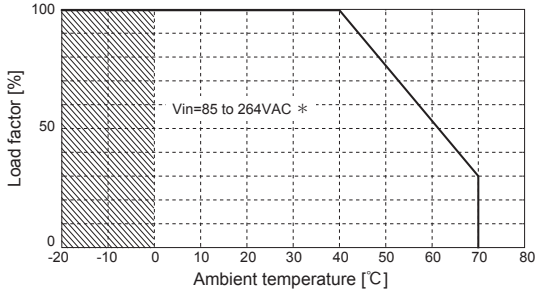

*With derating due to input voltage

● PCA1000F-24, -32, -48
Ambient Temperature Derating Curve

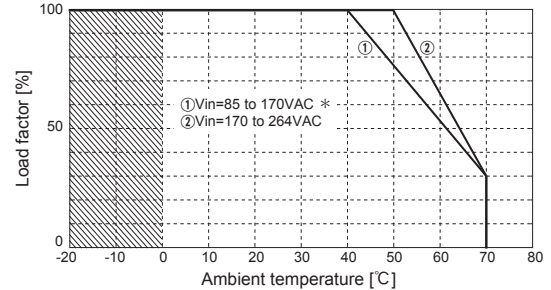

*With derating due to input voltage

● PCA1500F-5,-12,-15
Ambient Temperature Derating Curve

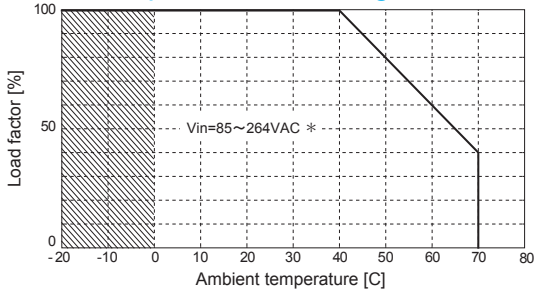

*With derating due to input voltage

● PCA1500F-24,-32,-48
Ambient Temperature Derating Curve

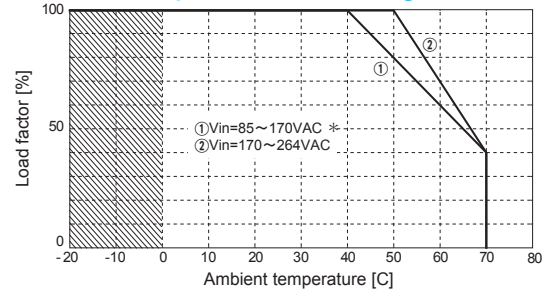

*With derating due to input voltage

- Specifications for ripple and ripple noise are different in the hatched area.
- The ambient temperature is defined as the temperature of the air at air-intake side of the power supply.

Instruction Manual

◆ It is necessary to read the "Instruction Manual" and "Before using our product" before you use our product.

Instruction Manual <https://www.cosel.co.jp/redirect/catalog/en/PCA/>
 Before using our product <https://en.cosel.co.jp/technical/caution/index.html>



Basic Characteristics Data

Model	Circuit method	Switching frequency [kHz]	Input current [A]	Rated input fuse	Inrush current protection circuit	PCB/Pattern			Series/Parallel operation availability	
						Material	Single sided	Double sided	Series operation	Parallel operation
PCA300F	Active filter	15 - 400	3.8	250V 10A	Relay	FR-4	-	Yes	Yes	Yes
	Buck converter	88								
	Full - bridge converter	44								
PCA600F	Active filter	15 - 400	7.3	250V 16A	Relay	FR-4	-	Yes	Yes	Yes
	Buck converter	88								
	Full - bridge converter	44								
PCA1000F	Active filter	15 - 400	12.0	250V 20A	Relay	FR-4	-	Yes	Yes	Yes
	Buck converter	88								
	Full - bridge converter	44								
PCA1500F	Active filter	15 - 400	18.0	250V 31.5A	Relay	FR-4	-	Yes	Yes	Yes
	Buck converter	88								
	Full - bridge converter	44								

* The value of input current is at ACIN 100VAC and rated load.



PBA, PBW-series

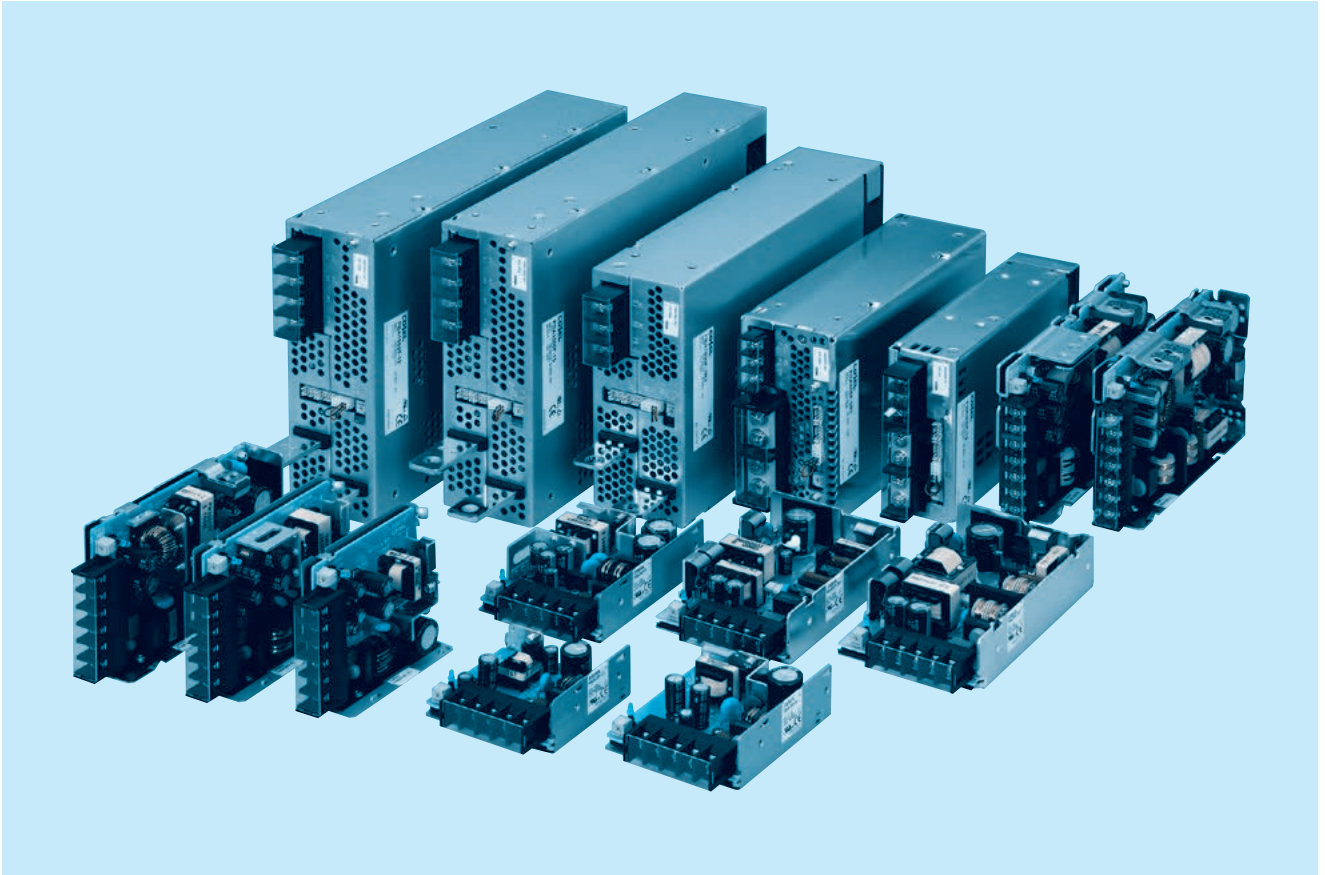

Feature

- Small-size & light weight
- Harmonic attenuator (Complies with IEC61000-3-2) : except PBA1500T
- Universal input (AC85 - 264V) : PBA1500T(AC170 - 264V 3 φ)
- Efficiency increased with synchronous rectification technology (PBA50F - 150F)
- Variety of option (PBA10F - 150F, PBW15F - 50F)
- Parallel operation and Parallel redundancy operation (PBA300F - 1500F, PBA1500T)
- Fan alarm, Remote ON/OFF and other functions (PBA300F - 1500F, PBA1500T)

Safety agency approvals

- UL60950-1, C-UL(CSA60950-1), EN62368-1
- UL508 (PBA10F - 150F, -24, with cover)
- Complies with DEN-AN

EMI

- Complies with FCC-B, CISPR22-B, EN55011-B, EN55022-B, VCCI-B

5-year warranty (refer to Instruction Manual)

CE marking

- Low Voltage Directive
- RoHS Directive

UKCA marking

- Electrical Equipment Safety Regulations
- RoHS Regulations

EMS Compliance : EN61204-3, EN61000-6-2

- EN61000-4-2
- EN61000-4-3
- EN61000-4-4
- EN61000-4-5
- EN61000-4-6
- EN61000-4-8
- EN61000-4-11

PBA10F

PB A 10 F -□ -□
 ① ② ③ ④ ⑤ ⑥

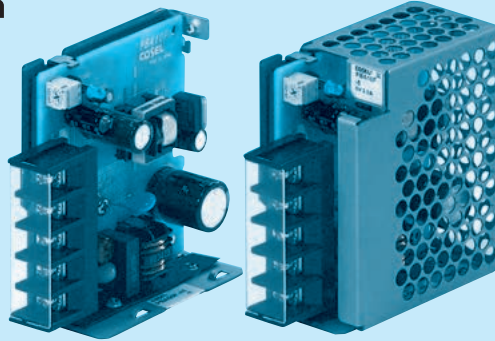
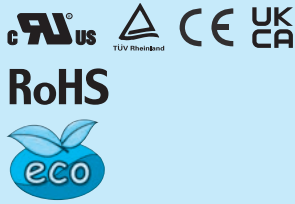

Example recommended EMI/EMC filter
NAC-06-472



High voltage pulse noise type : NAP series
 Low leakage current type : NAM series
 *A higher current rating EMI/EMC filter may be recommended in view of the other devices that could be connected in parallel with the power supply.

- ① Series name
- ② Single output
- ③ Output wattage
- ④ Universal input
- ⑤ Output voltage
- ⑥ Optional *5
- C : with Coating
- G : Low leakage current
- E : Low leakage current and EMI class A
- T : Vertical terminal block
- J1 : VH (J.S.T.) connector type
- N : with Cover (UL508 is acquired)
- N1 : with DIN rail and Cover
- V : Output voltage setting potentiometer externally

Cover is optional

*Make sure necessary tests will be carried out on your end equipment with the power supply installed in accordance with any required EMC/EMI regulations.

MODEL	PBA10F-5	PBA10F-12	PBA10F-24
MAX OUTPUT WATTAGE[W]	10	10.8	12
DC OUTPUT	5V 2A	12V 0.9A	24V 0.5A

SPECIFICATIONS

	MODEL	PBA10F-5	PBA10F-12	PBA10F-24	
INPUT	VOLTAGE[V]	AC85 - 264 1 φ or DC110 - 370 (AC50 or DC70 Please refer to the instruction manual 1.1 Input voltage *3)			
	CURRENT[A]	ACIN 100V	0.30typ (Io=100%)		
		ACIN 200V	0.20typ (Io=100%)		
	FREQUENCY[Hz]	50/60 (47 - 440) or DC			
	EFFICIENCY[%]	ACIN 100V	74typ	76typ	77typ
		ACIN 200V	74typ	76typ	77typ
	INRUSH CURRENT[A]	ACIN 100V	15typ (Io=100%)		
	ACIN 200V	30typ (Io=100%)			
LEAKAGE CURRENT[ma]	0.15/0.30max (ACIN 100V/240V 60Hz, Io=100%, According to IEC62368-1, DENAN)				
OUTPUT	VOLTAGE[V]	5	12	24	
	CURRENT[A]	2	0.9	0.5	
	LINE REGULATION[mV] *6	20max	48max	96max	
	LOAD REGULATION[mV] *6	40max	100max	150max	
	RIPPLE[mVp-p]	0 to +50°C *1	80max	120max	120max
		-10 - 0°C *1	140max	160max	160max
	RIPPLE NOISE[mVp-p]	0 to +50°C *1	120max	150max	150max
		-10 - 0°C *1	160max	180max	180max
	TEMPERATURE REGULATION[mV]	0 to +50°C	50max	120max	240max
		-10 to +50°C	60max	150max	290max
	DRIFT[mV] *2	20max	48max	96max	
START-UP TIME[ms]	200typ (ACIN 100V, Io=100%) *Start-up time is 700ms typ for less than 1minute of applying input again from turning off the input voltage.				
HOLD-UP TIME[ms]	20typ (ACIN 100V, Io=100%)				
OUTPUT VOLTAGE ADJUSTMENT RANGE[V]	4.50 - 5.50	10.0 - 13.2	19.2 - 27.0		
OUTPUT VOLTAGE SETTING[V]	5.00 - 5.15	12.00 - 12.48	24.00 - 24.96		
PROTECTION CIRCUIT AND OTHERS	OVERCURRENT PROTECTION	Works over 105% of rated current and recovers automatically			
	OVERVOLTAGE PROTECTION[V]	5.75 - 7.00	15.0 - 18.0	30.0 - 37.0	
	OPERATING INDICATION	LED (Green)			
	REMOTE ON/OFF	None			
ISOLATION	INPUT-OUTPUT	AC3,000V 1minute, Cutoff current = 10mA, DC500V 50MΩmin (At Room Temperature)			
	INPUT-FG	AC2,000V 1minute, Cutoff current = 10mA, DC500V 50MΩmin (At Room Temperature)			
	OUTPUT-FG	AC500V 1minute, Cutoff current = 25mA, DC500V 50MΩmin (At Room Temperature)			
ENVIRONMENT	OPERATING TEMP.,HUMID.AND ALTITUDE	-10 to +71°C (Refer to "Derating"), 20 - 90%RH (Non condensing) 3,000m (10,000feet) max			
	STORAGE TEMP.,HUMID.AND ALTITUDE	-20 to +75°C, 20 - 90%RH (Non condensing) 9,000m (30,000feet) max			
	VIBRATION	10 - 55Hz, 19.6m/s ² (2G), 3minutes period, 60minutes each along X, Y and Z axis			
	IMPACT	196.1m/s ² (20G), 11ms, once each X, Y and Z axis			
SAFETY AND NOISE REGULATIONS	AGENCY APPROVALS (At only AC input)	UL60950-1, C-UL(CSA60950-1), EN62368-1 Complies with DEN-AN			
	CONDUCTED NOISE	Complies with FCC Part15 classB, VCCI-B, CISPR22-B, EN55011-B, EN55022-B			
	HARMONIC ATTENUATOR	Complies with IEC61000-3-2 (Not built-in to active filter *4) *7			
OTHERS	CASE SIZE/WEIGHT	31×78×68mm [1.22×3.07×2.68 inches] (without terminal block) (W×H×D) / 150g max (with cover : 180g max)			
	COOLING METHOD	Convection			

*1 Measured by 20MHz oscilloscope or Ripple-Noise meter(equivalent to KEISOKU-GIKEN :RM101).
 *2 Drift is the change in DC output for an eight hour period after a half-hour warm-up at 25°C.
 *3 Derating is required.
 *4 When two or more units are used,they may not comply with the harmonic attenuator. Please contact us for details.

*5 Please contact us about safety approvals for the model with option.
 *6 Please contact us about dynamic load and input response.
 *7 Please contact us about class C.
 * Parallel operation with other model is not possible.
 * Derating is required when operated with cover.
 * A sound may occur from power supply at peak loading.

Block diagram

PBA/PBW

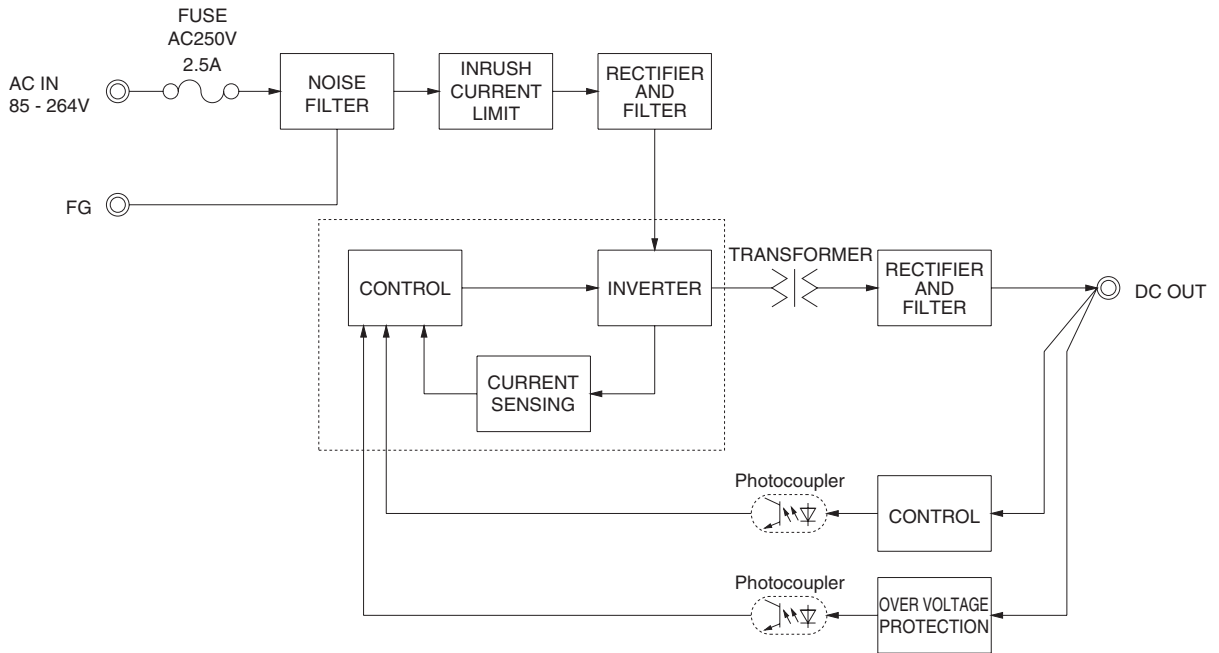

External view

※ External size of option T,J1,N1 and V is different from standard model and refer to 7 Option of instruction manual for details.

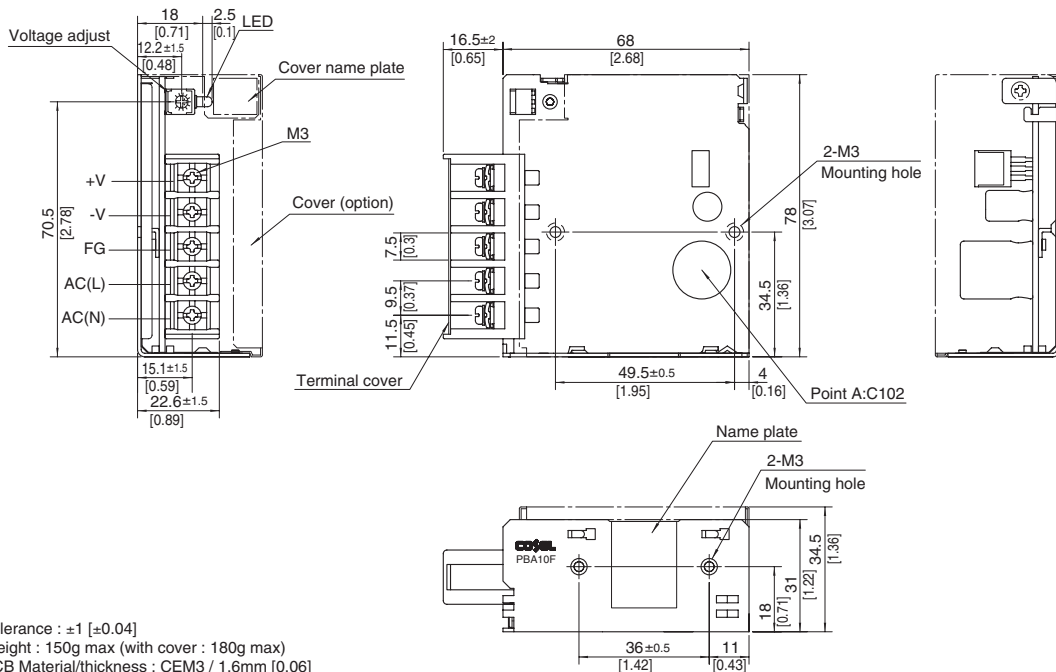

- ※ Tolerance : ±1 [±0.04]
- ※ Weight : 150g max (with cover : 180g max)
- ※ PCB Material/thickness : CEM3 / 1.6mm [0.06]
- ※ Chassis material : Hot-dip galvanized steel plate
- ※ Dimensions in mm, [] = inches
- ※ Mounting torque : 0.6N • m (6.3kgf • cm) max
- ※ Screw tightening torque : M3 0.8N • m (8.5kgf • cm) max
- ※ Please connect safety ground to the unit in 2-M3 holes.

PBA15F

PB A 15 F -□ -□
 ① ② ③ ④ ⑤ ⑥

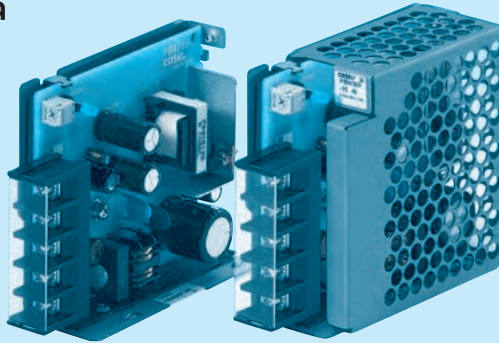
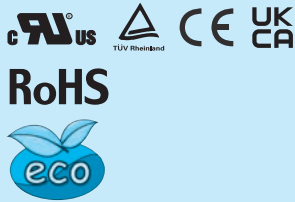

Example recommended EMI/EMC filter
NAC-06-472



High voltage pulse noise type : NAP series
 Low leakage current type : NAM series
 *A higher current rating EMI/EMC filter may be recommended in view of the other devices that could be connected in parallel with the power supply.

- ① Series name
- ② Single output
- ③ Output wattage
- ④ Universal input
- ⑤ Output voltage
- ⑥ Optional *5
- C : with Coating
- G : Low leakage current
- E : Low leakage current and EMI class A
- T : Vertical terminal block
- J1 : V.H (J.S.T.) connector type
- N : with Cover (UL508 is acquired [5V, 12V, 24V])
- N1 : with DIN rail and Cover
- V : Output voltage setting potentiometer externally

Cover is optional

*Make sure necessary tests will be carried out on your end equipment with the power supply installed in accordance with any required EMC/EMI regulations.

MODEL	PBA15F-3R3	PBA15F-5	PBA15F-9	PBA15F-12	PBA15F-15	PBA15F-24	PBA15F-48
MAX OUTPUT WATTAGE[W]	9.9	15	15.3	15.6	15	16.8	16.8
DC OUTPUT	3.3V 3A	5V 3A	9V 1.7A	12V 1.3A	15V 1A	24V 0.7A	48V 0.35A

SPECIFICATIONS

	MODEL	PBA15F-3R3	PBA15F-5	PBA15F-9	PBA15F-12	PBA15F-15	PBA15F-24	PBA15F-48	
INPUT	VOLTAGE[V]	AC85 - 264 1 φ or DC110 - 370 (AC50 or DC70 Please refer to the instruction manual 1.1 Input voltage *3)							
	CURRENT[A]	ACIN 100V	0.30typ (Io=100%)	0.4typ (Io=100%)					
		ACIN 200V	0.15typ (Io=100%)	0.2typ (Io=100%)					
	FREQUENCY[Hz]	50/60 (47 - 440) or DC							
	EFFICIENCY[%]	ACIN 100V	68typ	74typ	75typ	75typ	77typ	75typ	75typ
		ACIN 200V	68typ	75typ	77typ	78typ	80typ	78typ	78typ
	INRUSH CURRENT[A]	ACIN 100V	15typ (Io=100%) (At cold start)						
	ACIN 200V	30typ (Io=100%) (At cold start)							
LEAKAGE CURRENT[ma]	0.15/0.30max (ACIN 100V/240V 60Hz, Io=100%, According to IEC62368-1.DENAN)								
OUTPUT	VOLTAGE[V]	3.3	5	9	12	15	24	48	
	CURRENT[A]	3	3	1.7	1.3	1	0.7	0.35	
	LINE REGULATION[mV] *6	20max	20max	36max	48max	60max	96max	192max	
	LOAD REGULATION[mV] *6	40max	40max	100max	100max	120max	150max	240max	
	RIPPLE[mVp-p]	0 to +50°C *1	80max	80max	120max	120max	120max	120max	150max
		-10 - 0°C *1	140max	140max	160max	160max	160max	160max	200max
	RIPPLE NOISE[mVp-p]	0 to +50°C *1	120max	120max	150max	150max	150max	150max	250max
		-10 - 0°C *1	160max	160max	180max	180max	180max	180max	300max
	TEMPERATURE REGULATION[mV]	0 to +50°C	50max	50max	90max	120max	150max	240max	480max
		-10 to +50°C	60max	60max	120max	150max	180max	290max	600max
	DRIFT[mV] *2	20max	20max	36max	48max	60max	96max	192max	
START-UP TIME[ms]	200typ(ACIN 100V, Io=100%) *Start-up time is 700ms typ for less than 1minute of applying input again from turning off the input voltage.								
HOLD-UP TIME[ms]	20typ (ACIN 100V, Io=100%)								
OUTPUT VOLTAGE ADJUSTMENT RANGE[V]	2.85 - 3.60	4.50 - 5.50	7.50 - 10.0	10.0 - 13.2	13.2 - 18.0	19.2 - 27.0	39.0 - 53.0		
OUTPUT VOLTAGE SETTING[V]	3.30 - 3.40	5.00 - 5.15	9.00 - 9.36	12.00 - 12.48	15.00 - 15.60	24.00 - 24.96	48.00 - 49.92		
PROTECTION CIRCUIT AND OTHERS	OVERCURRENT PROTECTION	Works over 105% of rated current and recovers automatically							
	OVERVOLTAGE PROTECTION[V]	4.00 - 5.25	5.75 - 7.00	11.5 - 14.0	15.0 - 18.0	20.0 - 25.0	30.0 - 37.0	58.0 - 65.0	
	OPERATING INDICATION	LED (Green)							
	REMOTE ON/OFF	None							
ISOLATION	INPUT-OUTPUT	AC3,000V 1minute, Cutoff current = 10mA, DC500V 50MΩmin (At Room Temperature)							
	INPUT-FG	AC2,000V 1minute, Cutoff current = 10mA, DC500V 50MΩmin (At Room Temperature)							
	OUTPUT-FG	AC500V 1minute, Cutoff current = 25mA, DC500V 50MΩmin (At Room Temperature)							
ENVIRONMENT	OPERATING TEMP.,HUMID.AND ALTITUDE	-10 to +71°C (Refer to "Derating"), 20 - 90%RH (Non condensing) 3,000m (10,000feet) max							
	STORAGE TEMP.,HUMID.AND ALTITUDE	-20 to +75°C, 20 - 90%RH (Non condensing) 9,000m (30,000feet) max							
	VIBRATION	10 - 55Hz, 19.6m/s ² (2G), 3minutes period, 60minutes each along X, Y and Z axis							
	IMPACT	196.1m/s ² (20G), 11ms, once each X, Y and Z axis							
SAFETY AND NOISE REGULATIONS	AGENCY APPROVALS (At only AC input)	UL60950-1, C-UL(CSA60950-1), EN62368-1 Complies with DEN-AN							
	CONDUCTED NOISE	Complies with FCC Part15 classB, VCCI-B, CISPR22-B, EN55011-B, EN55022-B							
	HARMONIC ATTENUATOR	Complies with IEC61000-3-2 (Not built-in to active filter *4) *7							
OTHERS	CASE SIZE/WEIGHT	31 × 78 × 85mm [1.22 × 3.07 × 3.35 inches] (without terminal block) (W×H×D) / 200g max (with cover : 235g max)							
	COOLING METHOD	Convection							

*1 Measured by 20MHz oscilloscope or Ripple-Noise meter(equivalent to KEISOKU-GIKEN :RM101).
 *2 Drift is the change in DC output for an eight hour period after a half-hour warm-up at 25°C.
 *3 Derating is required.
 *4 When two or more units are used,they may not comply with the harmonic attenuator. Please contact us for details.

*5 Please contact us about safety approvals for the model with option.
 *6 Please contact us about dynamic load and input response.
 *7 Please contact us about class C.
 * Parallel operation with other model is not possible.
 * Derating is required when operated with cover.
 * A sound may occur from power supply at peak loading.

Block diagram

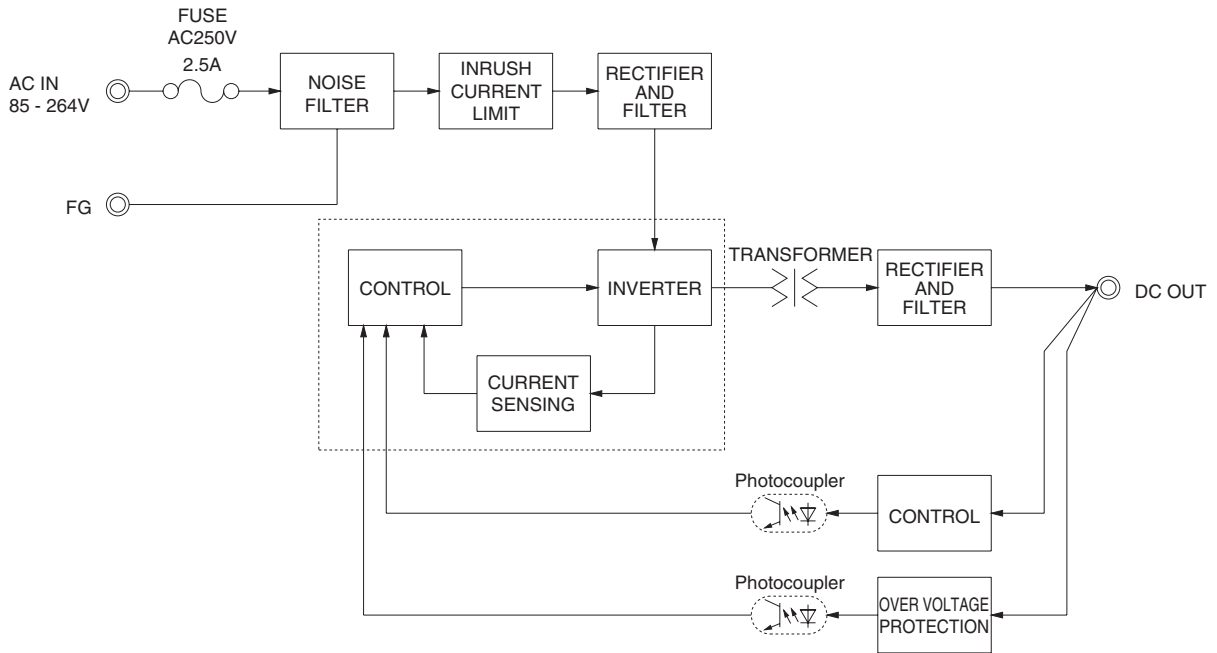

External view

※ External size of option T,J1,N1 and V is different from standard model and refer to 7 Option of instruction manual for details.

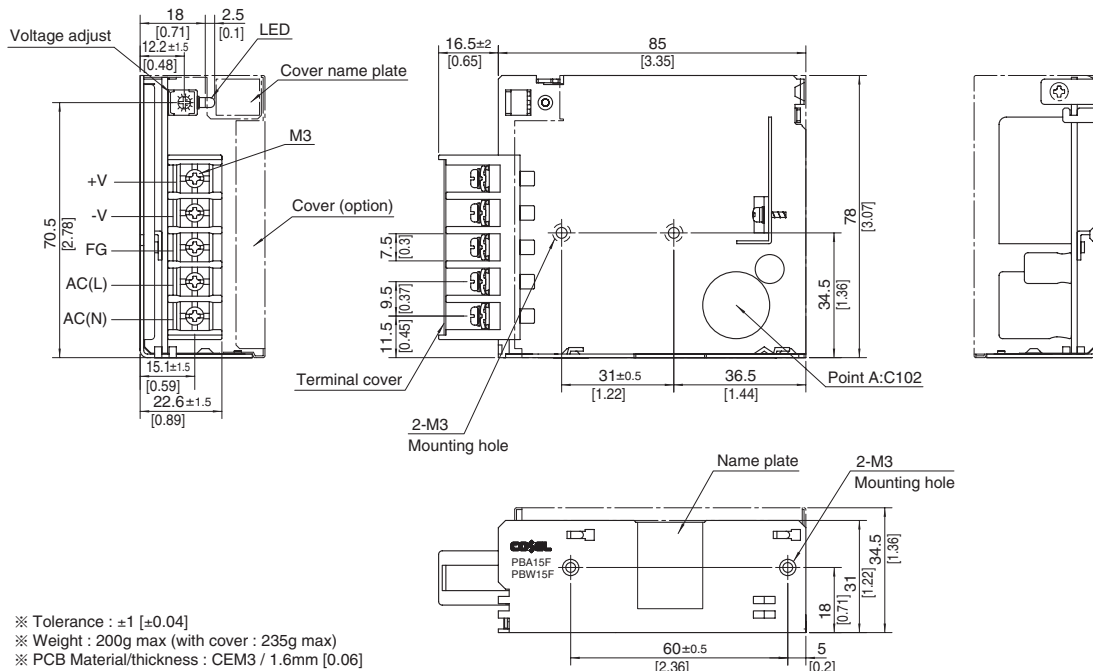

- ※ Tolerance : ±1 [±0.04]
- ※ Weight : 200g max (with cover : 235g max)
- ※ PCB Material/thickness : CEM3 / 1.6mm [0.06]
- ※ Chassis material : Hot-dip galvanized steel plate
- ※ Dimensions in mm, [] = inches
- ※ Mounting torque : 0.6N • m(6.3kgf • cm)max
- ※ Screw tightening torque : M3 0.8N • m(8.5kgf • cm)max
- ※ Please connect safety ground to the unit in 2-M3 holes.

PBA30F

PB A 30 F -□ -□
 ① ② ③ ④ ⑤ ⑥

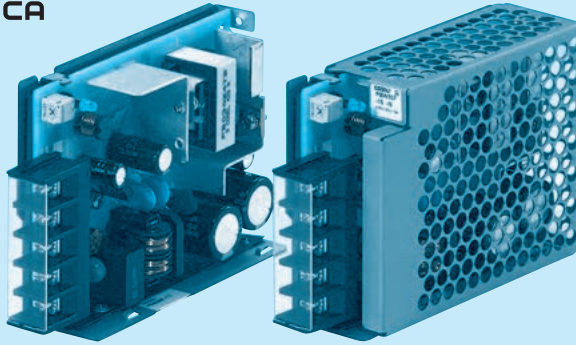
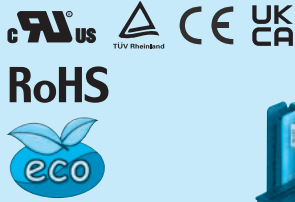

Example recommended EMI/EMC filter
NAC-06-472



High voltage pulse noise type : NAP series
 Low leakage current type : NAM series
 *A higher current rating EMI/EMC filter may be recommended in view of the other devices that could be connected in parallel with the power supply.

- ① Series name
- ② Single output
- ③ Output wattage
- ④ Universal input
- ⑤ Output voltage
- ⑥ Optional *5
- C :with Coating
- G :Low leakage current
- E :Low leakage current and EMI class A
- T :Vertical terminal block
- J1 :VH (J.S.T.) connector type
- N :with Cover (UL508 is acquired [5V, 12V, 24V])
- N1 :with DIN rail and Cover
- V :Output voltage setting potentiometer externally

Cover is optional

*Make sure necessary tests will be carried out on your end equipment with the power supply installed in accordance with any required EMC/EMI regulations.

MODEL	PBA30F-3R3	PBA30F-5	PBA30F-9	PBA30F-12	PBA30F-15	PBA30F-24	PBA30F-48
MAX OUTPUT WATTAGE[W]	19.8	30	30.6	30	30	31.2	31.2
DC OUTPUT	3.3V 6A	5V 6A	9V 3.4A	12V 2.5A	15V 2A	24V 1.3A	48V 0.65A

SPECIFICATIONS

	MODEL	PBA30F-3R3	PBA30F-5	PBA30F-9	PBA30F-12	PBA30F-15	PBA30F-24	PBA30F-48	
INPUT	VOLTAGE[V]	AC85 - 264 1 φ or DC110 - 370 (AC50 or DC70 Please refer to the instruction manual 1.1 Input voltage *3)							
	CURRENT[A]	ACIN 100V	0.50typ (Io=100%)		0.70typ (Io=100%)				
		ACIN 200V	0.30typ (Io=100%)		0.40typ (Io=100%)				
	FREQUENCY[Hz]	50/60 (47 - 440) or DC							
	EFFICIENCY[%]	ACIN 100V	68typ	74typ	75typ	76typ	78typ	78typ	79typ
		ACIN 200V	69typ	77typ	77typ	78typ	81typ	81typ	81typ
	INRUSH CURRENT[A]	ACIN 100V	15typ (Io=100%) (At cold start)						
	ACIN 200V	30typ (Io=100%) (At cold start)							
LEAKAGE CURRENT[ma]	0.30/0.65max (ACIN 100V/240V 60Hz, Io=100%, According to IEC62368-1.DENAN)								
OUTPUT	VOLTAGE[V]	3.3	5	9	12	15	24	48	
	CURRENT[A]	6	6	3.4	2.5	2	1.3	0.65	
	LINE REGULATION[mV] *6	20max	20max	36max	48max	60max	96max	192max	
	LOAD REGULATION[mV] *6	40max	40max	100max	100max	120max	150max	240max	
	RIPPLE[mVp-p]	0 to +50°C *1	80max	80max	120max	120max	120max	120max	150max
		-10 - 0°C *1	140max	140max	160max	160max	160max	160max	200max
	RIPPLE NOISE[mVp-p]	0 to +50°C *1	120max	120max	150max	150max	150max	150max	250max
		-10 - 0°C *1	160max	160max	180max	180max	180max	180max	300max
	TEMPERATURE REGULATION[mV]	0 to +50°C	50max	50max	90max	120max	150max	240max	480max
		-10 to +50°C	60max	60max	120max	150max	180max	290max	600max
	DRIFT[mV] *2	20max	20max	36max	48max	60max	96max	192max	
START-UP TIME[ms]	200typ(ACIN 100V, Io=100%) *Start-up time is 700ms typ for less than 1minute of applying input again from turning off the input voltage.								
HOLD-UP TIME[ms]	20typ (ACIN 100V, Io=100%)								
OUTPUT VOLTAGE ADJUSTMENT RANGE[V]	2.85 - 3.60	4.50 - 5.50	7.50 - 10.0	10.0 - 13.2	13.2 - 18.0	19.2 - 27.0	39.0 - 53.0		
OUTPUT VOLTAGE SETTING[V]	3.30 - 3.40	5.00 - 5.15	9.00 - 9.36	12.00 - 12.48	15.00 - 15.60	24.00 - 24.96	48.00 - 49.92		
PROTECTION CIRCUIT AND OTHERS	OVERCURRENT PROTECTION	Works over 105% of rated current and recovers automatically							
	OVERVOLTAGE PROTECTION[V]	4.00 - 5.25	5.75 - 7.00	11.5 - 14.0	15.0 - 18.0	20.0 - 25.0	30.0 - 37.0	58.0 - 65.0	
	OPERATING INDICATION	LED (Green)							
	REMOTE ON/OFF	None							
ISOLATION	INPUT-OUTPUT	AC3,000V 1minute, Cutoff current = 10mA, DC500V 50MΩmin (At Room Temperature)							
	INPUT-FG	AC2,000V 1minute, Cutoff current = 10mA, DC500V 50MΩmin (At Room Temperature)							
	OUTPUT-FG	AC500V 1minute, Cutoff current = 25mA, DC500V 50MΩmin (At Room Temperature)							
ENVIRONMENT	OPERATING TEMP.,HUMID.AND ALTITUDE	-10 to +71°C (Refer to "Derating"), 20 - 90%RH (Non condensing) 3,000m (10,000feet) max							
	STORAGE TEMP.,HUMID.AND ALTITUDE	-20 to +75°C, 20 - 90%RH (Non condensing) 9,000m (30,000feet) max							
	VIBRATION	10 - 55Hz, 19.6m/s ² (2G), 3minutes period, 60minutes each along X, Y and Z axis							
	IMPACT	196.1m/s ² (20G), 11ms, once each X, Y and Z axis							
SAFETY AND NOISE REGULATIONS	AGENCY APPROVALS (At only AC input)	UL60950-1, C-UL(CSA60950-1), EN62368-1 Complies with DEN-AN							
	CONDUCTED NOISE	Complies with FCC Part15 classB, VCCI-B, CISPR22-B, EN55011-B, EN55022-B							
	HARMONIC ATTENUATOR	Complies with IEC61000-3-2 (Not built-in to active filter *4) *7							
OTHERS	CASE SIZE/WEIGHT	31 × 78 × 103mm [1.22 × 3.07 × 4.06 inches] (without terminal block) (W × H × D) / 270g max (with cover : 310g max)							
	COOLING METHOD	Convection							

*1 Measured by 20MHz oscilloscope or Ripple-Noise meter(equivalent to KEISOKU-GIKEN :RM101).
 *2 Drift is the change in DC output for an eight hour period after a half-hour warm-up at 25°C.
 *3 Derating is required.
 *4 When two or more units are used,they may not comply with the harmonic attenuator. Please contact us for details.

*5 Please contact us about safety approvals for the model with option.
 *6 Please contact us about dynamic load and input response.
 *7 Please contact us about class C.
 * Parallel operation with other model is not possible.
 * Derating is required when operated with cover.
 * A sound may occur from power supply at peak loading.

Block diagram

PBA/PBW

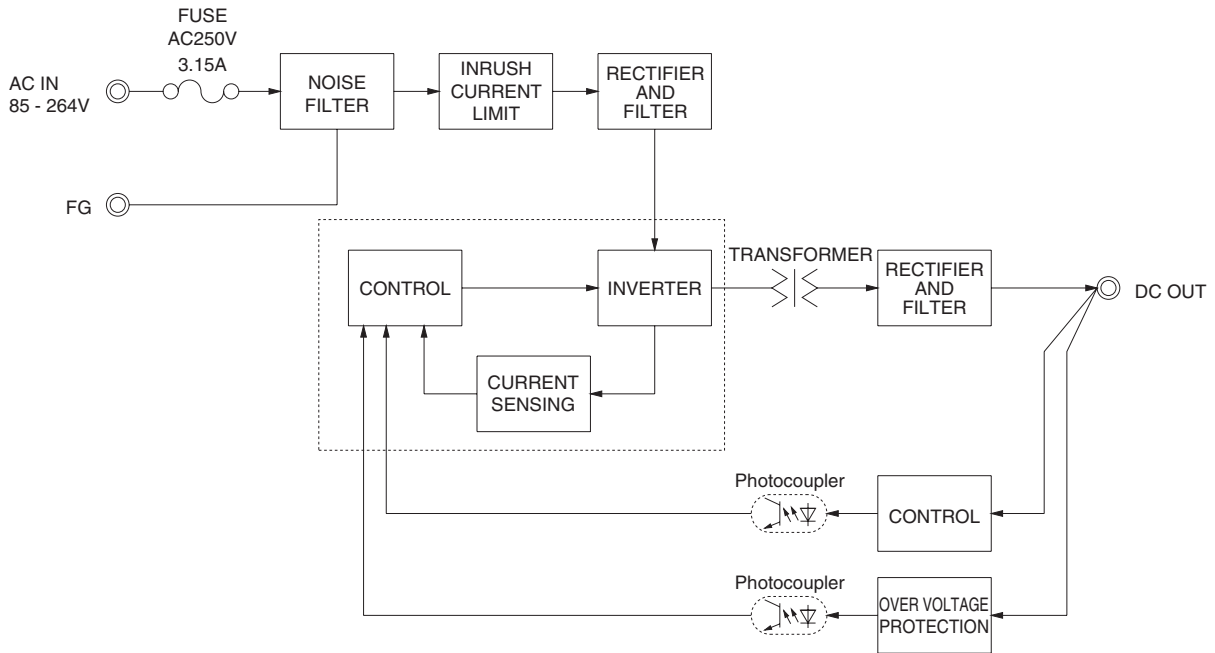

External view

※ External size of option T,J1,N1 and V is different from standard model and refer to 7 Option of instruction manual for details.

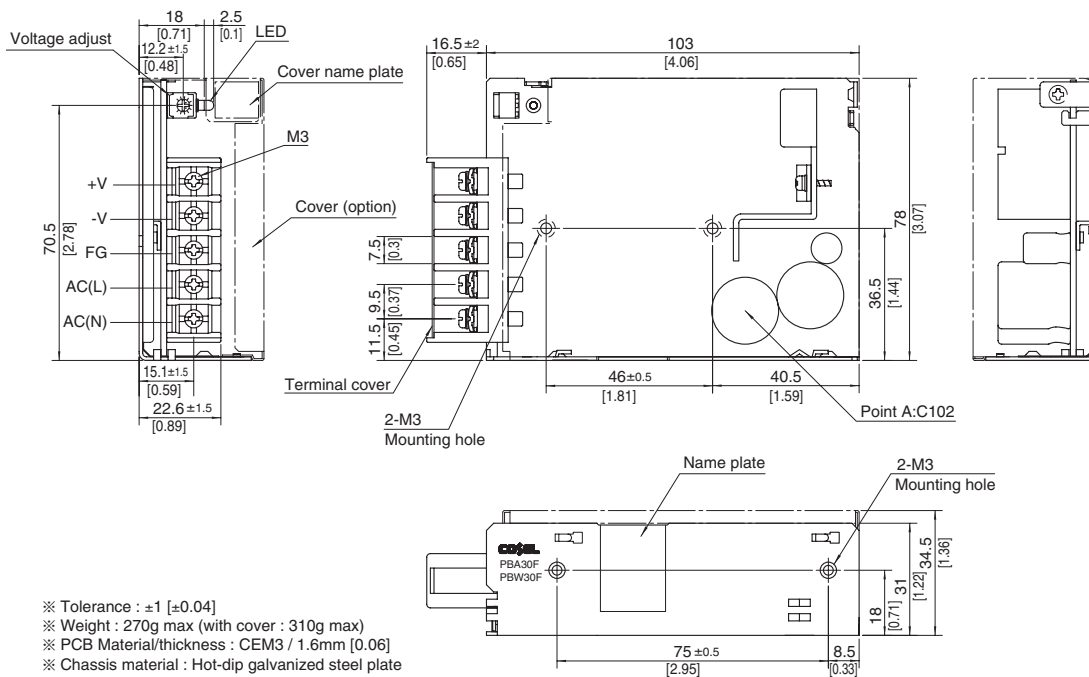

- ※ Tolerance : ± 1 [± 0.04]
- ※ Weight : 270g max (with cover : 310g max)
- ※ PCB Material/thickness : CEM3 / 1.6mm [0.06]
- ※ Chassis material : Hot-dip galvanized steel plate
- ※ Dimensions in mm, [] = inches
- ※ Mounting torque : $0.6\text{N} \cdot \text{m}$ (6.3kgf \cdot cm)max
- ※ Screw tightening torque : M3 $0.8\text{N} \cdot \text{m}$ (8.5kgf \cdot cm)max
- ※ Please connect safety ground to the unit in 2-M3 holes.

PBA50F

PB A 50 F -5 -□

① ② ③ ④ ⑤ ⑥

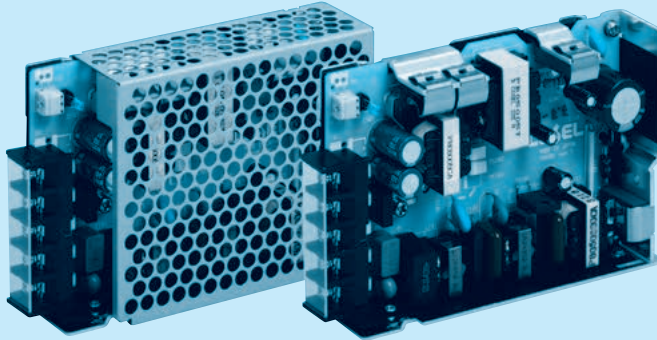

Example recommended EMI/EMC filter
NAC-06-472



High voltage pulse noise type : NAP series
Low leakage current type : NAM series
* A higher current rating EMI/EMC filter may be recommended in view of the other devices that could be connected in parallel with the power supply.

- ① Series name
- ② Single output
- ③ Output wattage
- ④ Universal input
- ⑤ Output voltage
- ⑥ Optional *5
- C :with Coating
- G :Low leakage current (0.15mA max / ACIN 240V)
- E :Low leakage current and EMI class A (0.5mA max / ACIN 240V)
- T :Vertical terminal block
- J1 :VH (J.S.T.) connector type
- R :with Remote ON/OFF
- N :with Cover (Only 24V UL508 is acquired)
- N1 :with DIN rail and Cover
- V :Output voltage setting potentiometer externaly

Cover is optional

*Make sure necessary tests will be carried out on your end equipment with the power supply installed in accordance with any required EMC/EMI regulations.

MODEL	PBA50F-3R3	PBA50F-5	PBA50F-9	PBA50F-12	PBA50F-15	PBA50F-24	PBA50F-36	PBA50F-48
MAX OUTPUT WATTAGE[W]	33	50	50.4	51.6	52.5	52.8	50.4	52.8
DC OUTPUT	3.3V 10A	5V 10A	9V 5.6A	12V 4.3A	15V 3.5A	24V 2.2A	36V 1.4A	48V 1.1A

SPECIFICATIONS

MODEL	PBA50F-3R3	PBA50F-5	PBA50F-9	PBA50F-12	PBA50F-15	PBA50F-24	PBA50F-36	PBA50F-48		
INPUT	VOLTAGE[V] AC85 - 264 1 φ or DC120 - 370 (AC50 or DC70 Please refer to the instruction manual 1.1 Input voltage *4)									
	CURRENT[A]	ACIN 100V	0.5typ	0.7typ						
		ACIN 200V	0.3typ	0.4typ						
	FREQUENCY[Hz]	50/60 (47 - 63)								
	EFFICIENCY[%]	ACIN 100V	75typ	80typ	79typ	80typ	81typ	82typ	83typ	83typ
		ACIN 200V	76typ	82typ	81typ	82typ	83typ	84typ	85typ	85typ
	POWER FACTOR(lo=100%)	ACIN 100V	0.98typ	0.99typ						
ACIN 200V		0.87typ	0.93typ							
INRUSH CURRENT[A]	ACIN 100V	15typ (lo=100%) (At cold start)								
	ACIN 200V	30typ (lo=100%) (At cold start)								
LEAKAGE CURRENT[mA]	0.4/0.75max (ACIN 100V/240V 60Hz, lo=100%, According to IEC62368-1.DENAN)									
OUTPUT	VOLTAGE[V]	3.3	5	9	12	15	24	36	48	
	CURRENT[A]	10	10	5.6	4.3	3.5	2.2	1.4	1.1	
	LINE REGULATION[mV]	20max	20max	36max	48max	60max	96max	144max	192max	
	LOAD REGULATION[mV]	40max	40max	100max	100max	120max	150max	240max	240max	
	RIPPLE[mVp-p]	0 to +50°C *1	80max	80max	120max	120max	120max	120max	150max	150max
		-10 - 0°C *1	140max	140max	160max	160max	160max	160max	200max	200max
	RIPPLE NOISE[mVp-p]	0 to +50°C *1	120max	120max	150max	150max	150max	150max	250max	250max
		-10 - 0°C *1	160max	160max	180max	180max	180max	180max	300max	300max
	TEMPERATURE REGULATION[mV]	0 to +50°C	50max	50max	90max	120max	150max	240max	360max	480max
		-10 to +50°C	60max	60max	120max	150max	180max	290max	450max	600max
	DRIFT[mV]	*2	20max	20max	36max	48max	60max	96max	144max	192max
START-UP TIME[ms]	350typ(ACIN 100V, lo=100%)									
HOLD-UP TIME[ms]	20typ (ACIN 100V, lo=100%)									
OUTPUT VOLTAGE ADJUSTMENT RANGE[V]	2.85 - 3.63	4.00 - 5.50	7.50 - 10.0	10.0 - 13.2	13.2 - 18.0	19.2 - 27.0	28.8 - 39.6	39.0 - 53.0		
OUTPUT VOLTAGE SETTING[V]	3.30 - 3.40	5.00 - 5.15	9.00 - 9.36	12.00 - 12.48	15.00 - 15.60	24.00 - 24.96	35.00 - 37.44	48.00 - 49.92		
PROTECTION CIRCUIT AND OTHERS	OVERCURRENT PROTECTION	Works over 105% of rated current and recovers automatically								
	OVERVOLTAGE PROTECTION[V]	4.00 - 5.25	5.75 - 7.00	11.5 - 14.0	15.0 - 18.0	20.0 - 25.0	30.0 - 37.0	43.0 - 50.0	58.0 - 65.0	
	OPERATING INDICATION	LED (Green)								
REMOTE ON/OFF	Optional (Required external power source)									
ISOLATION	INPUT-OUTPUT - RC	*3 AC3.000V 1minute, Cutoff current = 10mA, DC500V 50MΩmin (At Room Temperature)								
	INPUT-FG	AC2.000V 1minute, Cutoff current = 10mA, DC500V 50MΩmin (At Room Temperature)								
	OUTPUT - RC-FG	*3 AC500V 1minute, Cutoff current = 100mA, DC500V 50MΩmin (At Room Temperature)								
ENVIRONMENT	OPERATING TEMP.,HUMID.AND ALTITUDE	-10 to +71°C (Refer to "Derating"), 20 - 90%RH (Non condensing) 3,000m (10,000feet) max								
	STORAGE TEMP.,HUMID.AND ALTITUDE	-20 to +75°C; 20 - 90%RH (Non condensing) 9,000m (30,000feet) max								
	VIBRATION	10 - 55Hz, 19.6m/s ² (2G), 3minutes period, 60minutes each along X, Y and Z axis								
SAFETY AND NOISE REGULATIONS	IMPACT	196.1m/s ² (20G), 11ms, once each X, Y and Z axis								
	AGENCY APPROVALS (At only AC input)	UL60950-1, C-UL(CSA60950-1), EN62368-1 Complies with DEN-AN								
	CONDUCTED NOISE	Complies with FCC Part15 classB, VCCI-B, CISPR22-B, EN55011-B, EN55022-B								
	HARMONIC ATTENUATOR	Complies with IEC61000-3-2 *6								
OTHERS	CASE SIZE/WEIGHT	31 x 82 x 120mm [1.22 x 3.23 x 4.72 inches] (without terminal block) (W x H x D) / 280g max (with cover : 325g max)								
	COOLING METHOD	Convection								

*1 Measured by 20MHz oscilloscope or Ripple-Noise meter(equivalent to KEISOKU-GIKEN :RM101).
 *2 Drift is the change in DC output for an eight hour period after a half-hour warm-up at 25°C.
 *3 Applicable when Remote ON/OFF(optional) is added. RC is insulated with input, output and FG.
 *4 Derating is required.

*5 Please contact us about safety approvals for the model with option.
 *6 Please contact us about class C.
 * Parallel operation with other model is not possible.
 * Derating is required when operated with cover.
 * A sound may occur from power supply at peak loading.

Block diagram

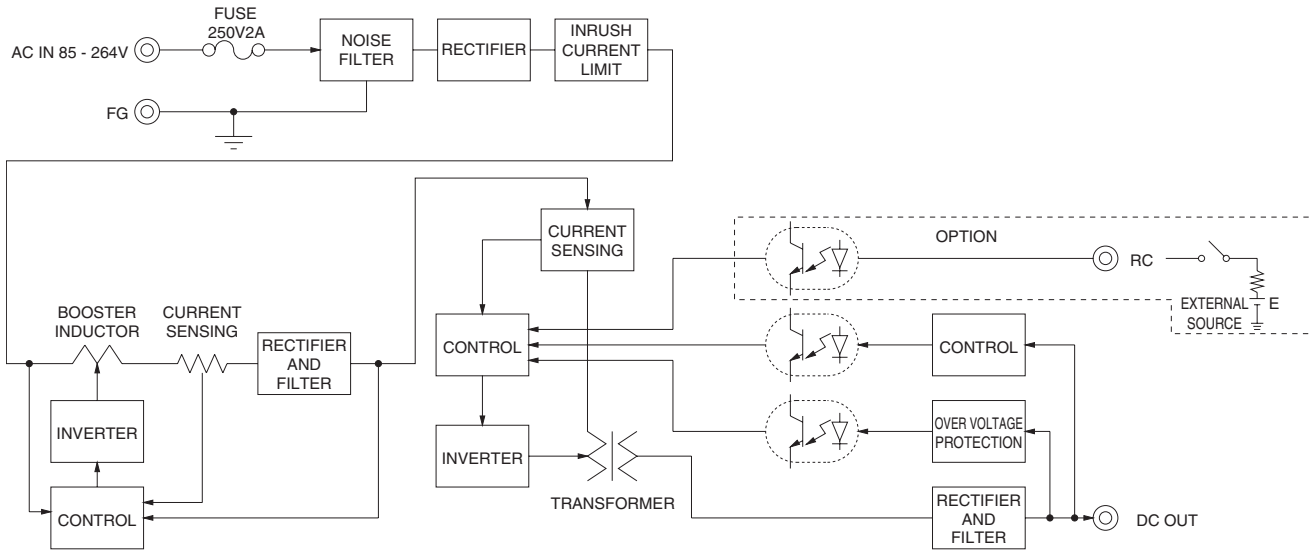

External view

※ External size of option T,J1,R,N1 and V is different from standard model and refer to 7 Option of instruction manual for details.

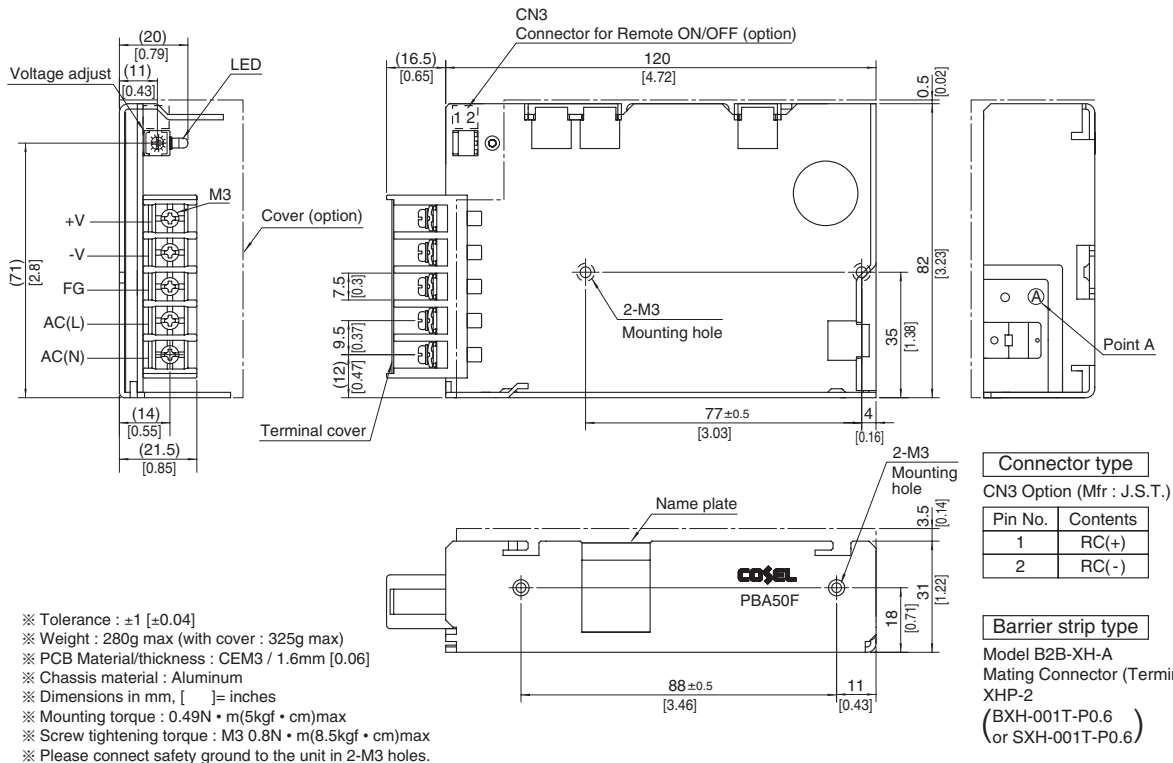

PBA75F

PB A 75 F -5 -□

① ② ③ ④ ⑤ ⑥

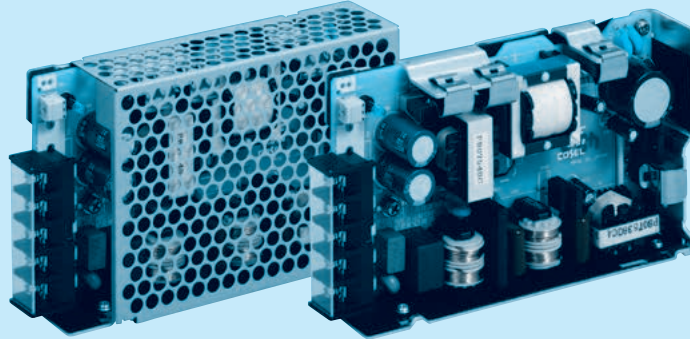

Example recommended EMI/EMC filter
NAC-06-472



High voltage pulse noise type : NAP series
Low leakage current type : NAM series
* A higher current rating EMI/EMC filter may be recommended in view of the other devices that could be connected in parallel with the power supply.

- ① Series name
- ② Single output
- ③ Output wattage
- ④ Universal input
- ⑤ Output voltage
- ⑥ Optional *5
- C :with Coating
- G :Low leakage current (0.15mA max / ACIN 240V)
- E :Low leakage current and EMI class A (0.5mA max / ACIN 240V)
- T :Vertical terminal block
- J1 :VH (J.S.T.) connector type
- R :with Remote ON/OFF
- N :with Cover (Only 24V UL508 is acquired)
- N1 :with DIN rail and Cover
- V :Output voltage setting potentiometer externaly

Cover is optional

*Make sure necessary tests will be carried out on your end equipment with the power supply installed in accordance with any required EMC/EMI regulations.

MODEL	PBA75F-3R3	PBA75F-5	PBA75F-9	PBA75F-12	PBA75F-15	PBA75F-24	PBA75F-36	PBA75F-48
MAX OUTPUT WATTAGE[W]	49.5	75	75.6	75.6	75	76.8	75.6	76.8
DC OUTPUT	3.3V 15A	5V 15A	9V 8.4A	12V 6.3A	15V 5A	24V 3.2A	36V 2.1A	48V 1.6A

SPECIFICATIONS

MODEL	PBA75F-3R3	PBA75F-5	PBA75F-9	PBA75F-12	PBA75F-15	PBA75F-24	PBA75F-36	PBA75F-48
INPUT	AC85 - 264 1 φ or DC120 - 370 (AC50 or DC70 Please refer to the instruction manual 1.1 Input voltage *4)							
CURRENT[A]	ACIN 100V	0.7typ	1.0typ					
	ACIN 200V	0.4typ	0.5typ					
FREQUENCY[Hz]	50/60 (47 - 63)							
EFFICIENCY[%]	ACIN 100V	77typ	81typ	80typ	81typ	82typ	83typ	84typ
	ACIN 200V	78typ	83typ	82typ	83typ	84typ	85typ	86typ
POWER FACTOR(lo=100%)	ACIN 100V	0.98typ	0.99typ					
	ACIN 200V	0.87typ	0.93typ					
INRUSH CURRENT[A]	ACIN 100V	15typ (lo=100%) (At cold start)						
	ACIN 200V	30typ (lo=100%) (At cold start)						
LEAKAGE CURRENT[ma]	0.4/0.75max (ACIN 100V/240V 60Hz, lo=100%, According to IEC62368-1.DENAN)							
OUTPUT	VOLTAGE[V]	3.3	5	9	12	15	24	36
CURRENT[A]		15	15	8.4	6.3	5	3.2	2.1
LINE REGULATION[mV]		20max	20max	36max	48max	60max	96max	144max
LOAD REGULATION[mV]		40max	40max	100max	100max	120max	150max	240max
RIPPLE[mVp-p]	0 to +50°C *1	80max	80max	120max	120max	120max	120max	150max
	-10 - 0°C *1	140max	140max	160max	160max	160max	160max	200max
RIPPLE NOISE[mVp-p]	0 to +50°C *1	120max	120max	150max	150max	150max	150max	250max
	-10 - 0°C *1	160max	160max	180max	180max	180max	180max	300max
TEMPERATURE REGULATION[mV]	0 to +50°C	50max	50max	90max	120max	150max	240max	360max
	-10 to +50°C	60max	60max	120max	150max	180max	290max	450max
DRIFT[mV]	*2	20max	20max	36max	48max	60max	96max	144max
START-UP TIME[ms]	350typ(ACIN 100V, lo=100%)							
HOLD-UP TIME[ms]	20typ (ACIN 100V, lo=100%)							
OUTPUT VOLTAGE ADJUSTMENT RANGE[V]	2.85 - 3.63		4.00 - 5.50		7.50 - 10.0		10.0 - 13.2	
OUTPUT VOLTAGE SETTING[V]	3.30 - 3.40		5.00 - 5.15		9.00 - 9.36		12.00 - 12.48	
OVERCURRENT PROTECTION	Works over 105% of rated current and recovers automatically							
OVERVOLTAGE PROTECTION[V]	4.00 - 5.25		5.75 - 7.00		11.5 - 14.0		15.0 - 18.0	
OPERATING INDICATION	LED (Green)							
REMOTE ON/OFF	Optional (Required external power source)							
INPUT-OUTPUT - RC	*3 AC3.000V 1minute, Cutoff current = 10mA, DC500V 50MΩmin (At Room Temperature)							
INPUT-FG	AC2.000V 1minute, Cutoff current = 10mA, DC500V 50MΩmin (At Room Temperature)							
OUTPUT - RC-FG	*3 AC500V 1minute, Cutoff current = 100mA, DC500V 50MΩmin (At Room Temperature)							
OPERATING TEMP.,HUMID.AND ALTITUDE	-10 to +71°C (Refer to "Derating"), 20 - 90%RH (Non condensing) 3,000m (10,000feet) max							
STORAGE TEMP.,HUMID.AND ALTITUDE	-20 to +75°C; 20 - 90%RH (Non condensing) 9,000m (30,000feet) max							
VIBRATION	10 - 55Hz, 19.6m/s ² (2G), 3minutes period, 60minutes each along X, Y and Z axis							
IMPACT	196.1m/s ² (20G), 11ms, once each X, Y and Z axis							
AGENCY APPROVALS (At only AC input)	UL60950-1, C-UL(CSA60950-1), EN62368-1 Complies with DEN-AN							
CONDUCTED NOISE	Complies with FCC Part15 classB, VCCI-B, CISPR22-B, EN55011-B, EN55022-B							
HARMONIC ATTENUATOR	Complies with IEC61000-3-2 *6							
CASE SIZE/WEIGHT	32 x 82 x 135mm [1.26 x 3.23 x 5.31 inches] (without terminal block) (W x H x D) / 350g max (with cover : 400g max)							
COOLING METHOD	Convection							

*1 Measured by 20MHz oscilloscope or Ripple-Noise meter(equivalent to KEISOKU-GIKEN :RM101).
 *2 Drift is the change in DC output for an eight hour period after a half-hour warm-up at 25°C.
 *3 Applicable when Remote ON/OFF(optional) is added. RC is insulated with input, output and FG.
 *4 Derating is required.

*5 Please contact us about safety approvals for the model with option.
 *6 Please contact us about class C.
 * Parallel operation with other model is not possible.
 * Derating is required when operated with cover.
 * A sound may occur from power supply at peak loading.

Block diagram

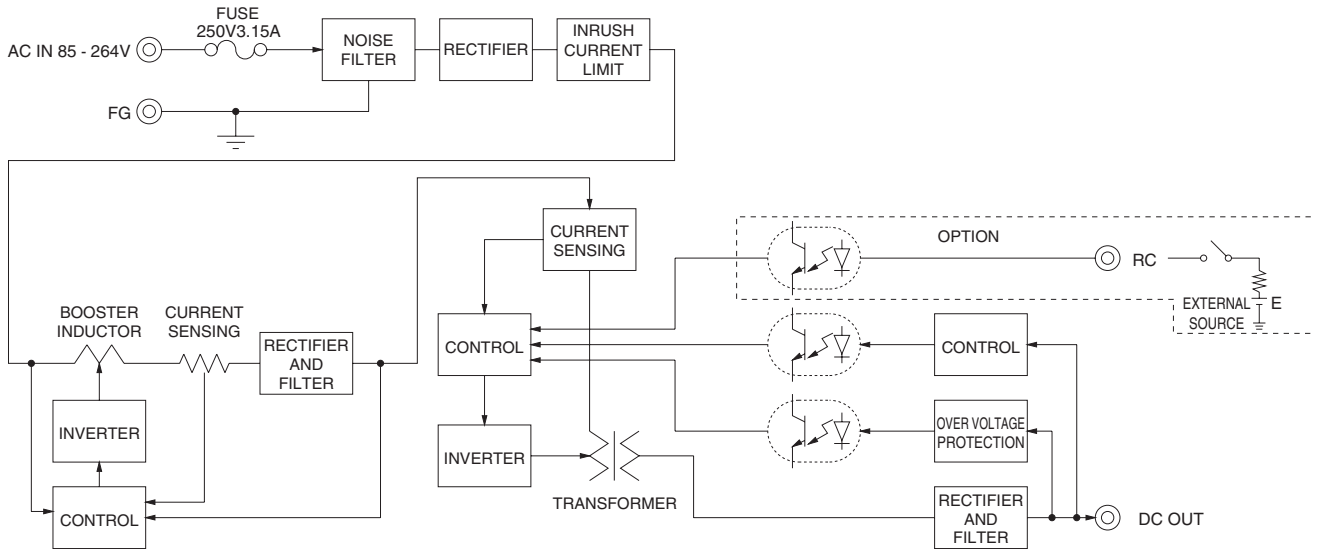

External view

※ External size of option T, J1, R, N1 and V is different from standard model and refer to 7 Option of instruction manual for details.

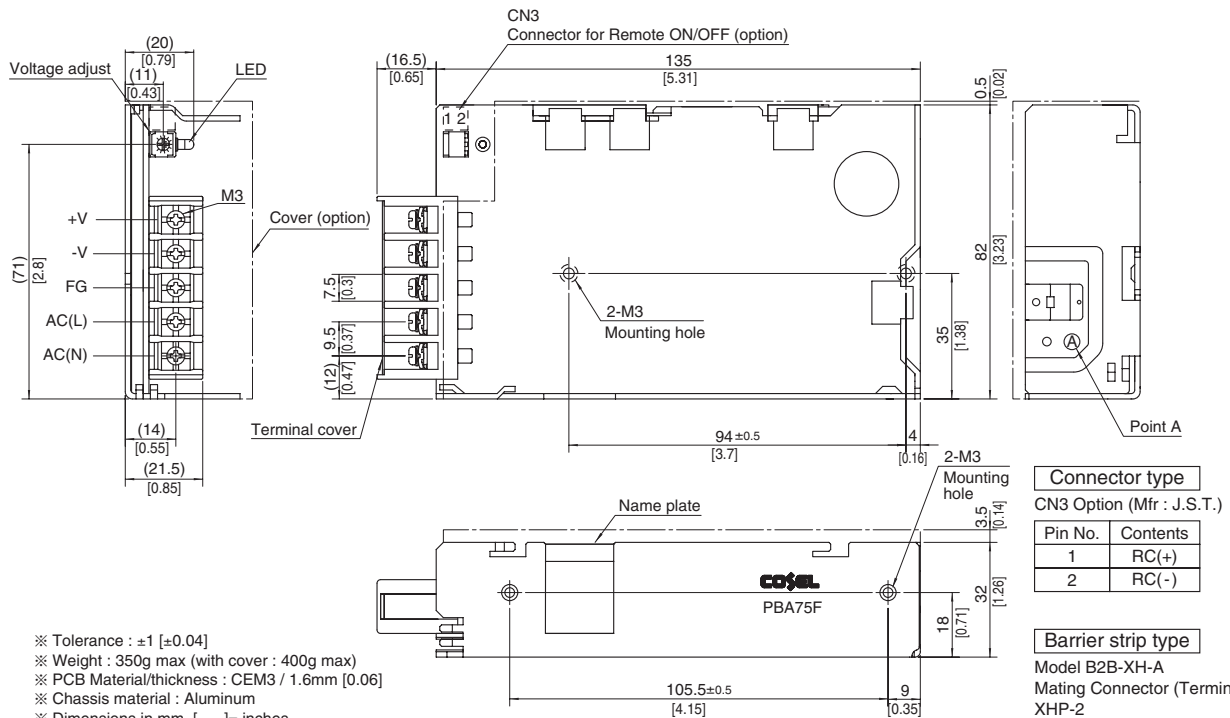

- ※ Tolerance : ±1 [±0.04]
- ※ Weight : 350g max (with cover : 400g max)
- ※ PCB Material/thickness : CEM3 / 1.6mm [0.06]
- ※ Chassis material : Aluminum
- ※ Dimensions in mm, [] = inches
- ※ Mounting torque : 0.49N · m (5kgf · cm) max
- ※ Screw tightening torque : M3 0.8N · m (8.5kgf · cm) max
- ※ Please connect safety ground to the unit in 2-M3 holes.

PBA100F

PB A 100 F -5 -□

① ② ③ ④ ⑤ ⑥

PBA/PBW

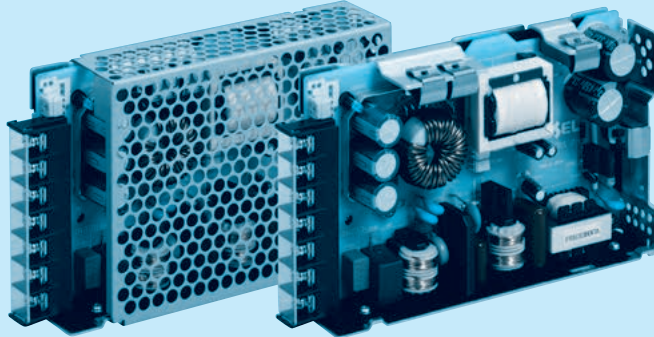

Example recommended EMI/EMC filter
NAC-06-472



High voltage pulse noise type : NAP series
Low leakage current type : NAM series
* A higher current rating EMI/EMC filter may be recommended in view of the other devices that could be connected in parallel with the power supply.

- ① Series name
- ② Single output
- ③ Output wattage
- ④ Universal input
- ⑤ Output voltage
- ⑥ Optional *5
- C :with Coating
- G :Low leakage current (0.15mA max / ACIN 240V)
- E :Low leakage current and EMI class A (0.5mA max / ACIN 240V)
- T :Vertical terminal block
- J1 :VH (J.S.T.) connector type (Only -12,-15,-24,-36,-48)
- R :with Remote ON/OFF
- N :with Cover (Only 24V UL508 is acquired)
- NI :with DIN rail and Cover
- V :Output voltage setting potentiometer external-ly

Cover is optional

* Make sure necessary tests will be carried out on your end equipment with the power supply installed in accordance with any required EMC/EMI regulations.

MODEL	PBA100F-3R3	PBA100F-5	PBA100F-9	PBA100F-12	PBA100F-15	PBA100F-24	PBA100F-36	PBA100F-48
MAX OUTPUT WATTAGE[W]	66	100	94.5	102	105	108	100.8	100.8
DC OUTPUT	3.3V 20A	5V 20A	9V 10.5A	12V 8.5A	15V 7A	24V 4.5A	36V 2.8A	48V 2.1A

SPECIFICATIONS

	MODEL	PBA100F-3R3	PBA100F-5	PBA100F-9	PBA100F-12	PBA100F-15	PBA100F-24	PBA100F-36	PBA100F-48	
INPUT	VOLTAGE[V]	AC85 - 264 1 φ or DC120 - 370 (AC50 or DC70 Please refer to the instruction manual 1.1 Input voltage *4)								
	CURRENT[A]	ACIN 100V	0.9typ	1.3typ						
		ACIN 200V	0.5typ	0.7typ						
	FREQUENCY[Hz]	50/60 (47 - 63)								
	EFFICIENCY[%]	ACIN 100V	77typ	82typ	80typ	81typ	83typ	84typ	84typ	84typ
		ACIN 200V	79typ	84typ	82typ	83typ	86typ	86typ	86typ	86typ
	POWER FACTOR(lo=100%)	ACIN 100V	0.98typ	0.99typ						
		ACIN 200V	0.87typ	0.93typ						
	INRUSH CURRENT[A]	ACIN 100V	20typ (lo=100%) (At cold start)							
		ACIN 200V	40typ (lo=100%) (At cold start)							
LEAKAGE CURRENT[mA]	0.4/0.75max (ACIN 100V/240V 60Hz, lo=100%, According to IEC62368-1, DENAN)									
OUTPUT	VOLTAGE[V]	3.3	5	9	12	15	24	36	48	
	CURRENT[A]	20	20	10.5	8.5	7	4.5	2.8	2.1	
	LINE REGULATION[mV]	20max	20max	36max	48max	60max	96max	144max	192max	
	LOAD REGULATION[mV]	40max	40max	100max	100max	120max	150max	240max	240max	
	RIPPLE[mVp-p]	0 to +50°C *1	80max	80max	120max	120max	120max	120max	150max	150max
		-10 - 0°C *1	140max	140max	160max	160max	160max	160max	200max	200max
	RIPPLE NOISE[mVp-p]	0 to +50°C *1	120max	120max	150max	150max	150max	150max	250max	250max
		-10 - 0°C *1	160max	160max	180max	180max	180max	180max	300max	300max
	TEMPERATURE REGULATION[mV]	0 to +50°C	50max	50max	90max	120max	150max	240max	360max	480max
		-10 to +50°C	60max	60max	120max	150max	180max	290max	450max	600max
	DRIFT[mV]	*2	20max	20max	36max	48max	60max	96max	144max	192max
	START-UP TIME[ms]	350typ(ACIN 100V, lo=100%)								
	HOLD-UP TIME[ms]	20typ (ACIN 100V, lo=100%)								
	OUTPUT VOLTAGE ADJUSTMENT RANGE[V]	2.85 - 3.63	4.00 - 5.50	7.50 - 10.0	10.0 - 13.2	13.2 - 18.0	19.2 - 27.0	28.8 - 39.6	39.0 - 53.0	
	OUTPUT VOLTAGE SETTING[V]	3.20 - 3.40	5.00 - 5.15	9.00 - 9.36	12.00 - 12.48	15.00 - 15.60	24.00 - 24.96	36.00 - 37.44	48.00 - 49.92	
PROTECTION CIRCUIT AND OTHERS	OVERCURRENT PROTECTION	Works over 105% of rated current and recovers automatically								
	OVERVOLTAGE PROTECTION[V]	4.00 - 5.25	5.75 - 7.00	11.5 - 14.0	15.0 - 18.0	20.0 - 25.0	30.0 - 37.0	43.0 - 50.0	58.0 - 65.0	
	OPERATING INDICATION	LED (Green)								
	REMOTE SENSING	Optional (Only -3R3, -5 Option -K)								
ISOLATION	REMOTE ON/OFF	Optional (Required external power source)								
	INPUT-OUTPUT · RC	*3	AC3.000V 1minute, Cutoff current = 10mA, DC500V 50MΩmin (At Room Temperature)							
	INPUT-FG	*3	AC2.000V 1minute, Cutoff current = 10mA, DC500V 50MΩmin (At Room Temperature)							
ENVIRONMENT	OUTPUT · RC-FG	*3	AC500V 1minute, Cutoff current = 100mA, DC500V 50MΩmin (At Room Temperature)							
	OPERATING TEMP.,HUMID.AND ALTITUDE	-10 to +71°C (Refer to "Derating"), 20 - 90%RH (Non condensing) 3,000m (10,000feet) max								
	STORAGE TEMP.,HUMID.AND ALTITUDE	-20 to +75°C, 20 - 90%RH (Non condensing) 9,000m (30,000feet) max								
SAFETY AND NOISE REGULATIONS	VIBRATION	10 - 55Hz, 19.6m/s ² (2G), 3minutes period, 60minutes each along X, Y and Z axis								
	IMPACT	196.1m/s ² (20G), 11ms, once each X, Y and Z axis								
	AGENCY APPROVALS (At only AC input)	UL60950-1, C-UL(CSA60950-1), EN62368-1 Complies with DEN-AN								
OTHERS	CONDUCTED NOISE	Complies with FCC Part15 classB, VCCI-B, CISPR22-B, EN55011-B, EN55022-B								
	HARMONIC ATTENUATOR	Complies with IEC61000-3-2 *6								
OTHERS	CASE SIZE/WEIGHT	32 x 93 x 147mm [1.26 x 3.66 x 5.79 inches] (without terminal block) (W x H x D) / 440g max (with cover : 500g max)								
	COOLING METHOD	Convection								

*1 Measured by 20MHz oscilloscope or Ripple-Noise meter(equivalent to KEISOKU-GIKEN :RM101).
 *2 Drift is the change in DC output for an eight hour period after a half-hour warm-up at 25°C.
 *3 Applicable when Remote ON/OFF(optional) is added. RC is insulated with input, output and FG.
 *4 Derating is required.

*5 Please contact us about safety approvals for the model with option.
 *6 Please contact us about class C.
 * Parallel operation with other model is not possible.
 * Derating is required when operated with cover.
 * A sound may occur from power supply at peak loading.

Block diagram

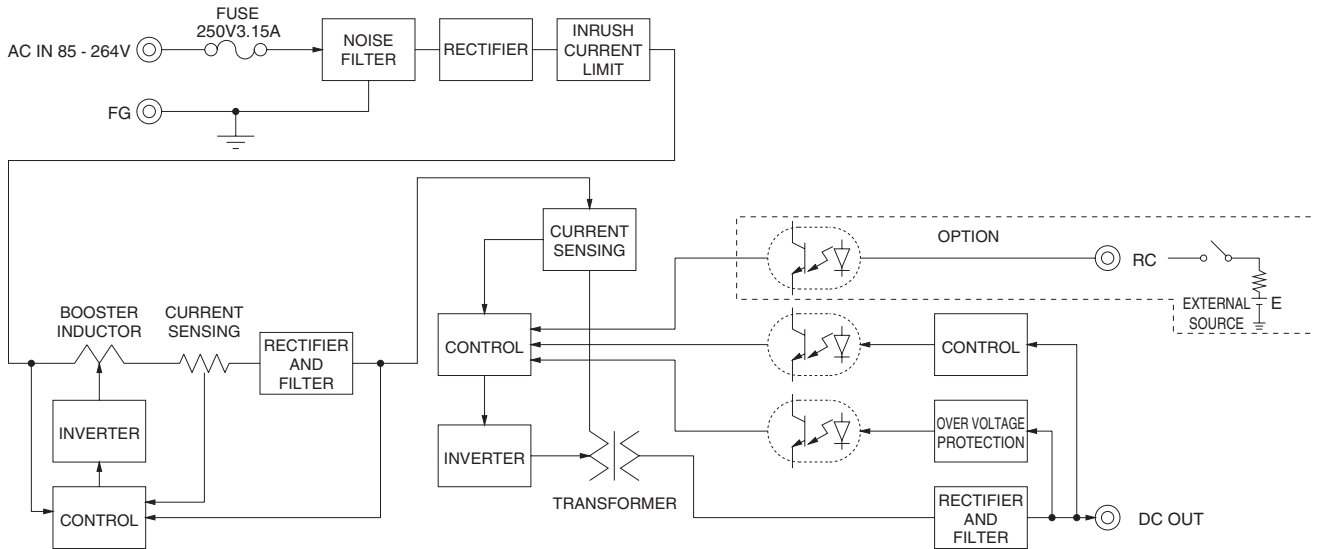

External view

※ External size of option T,J1,R,N1,V and K is different from standard model and refer to 7 Option of instruction manual for details.

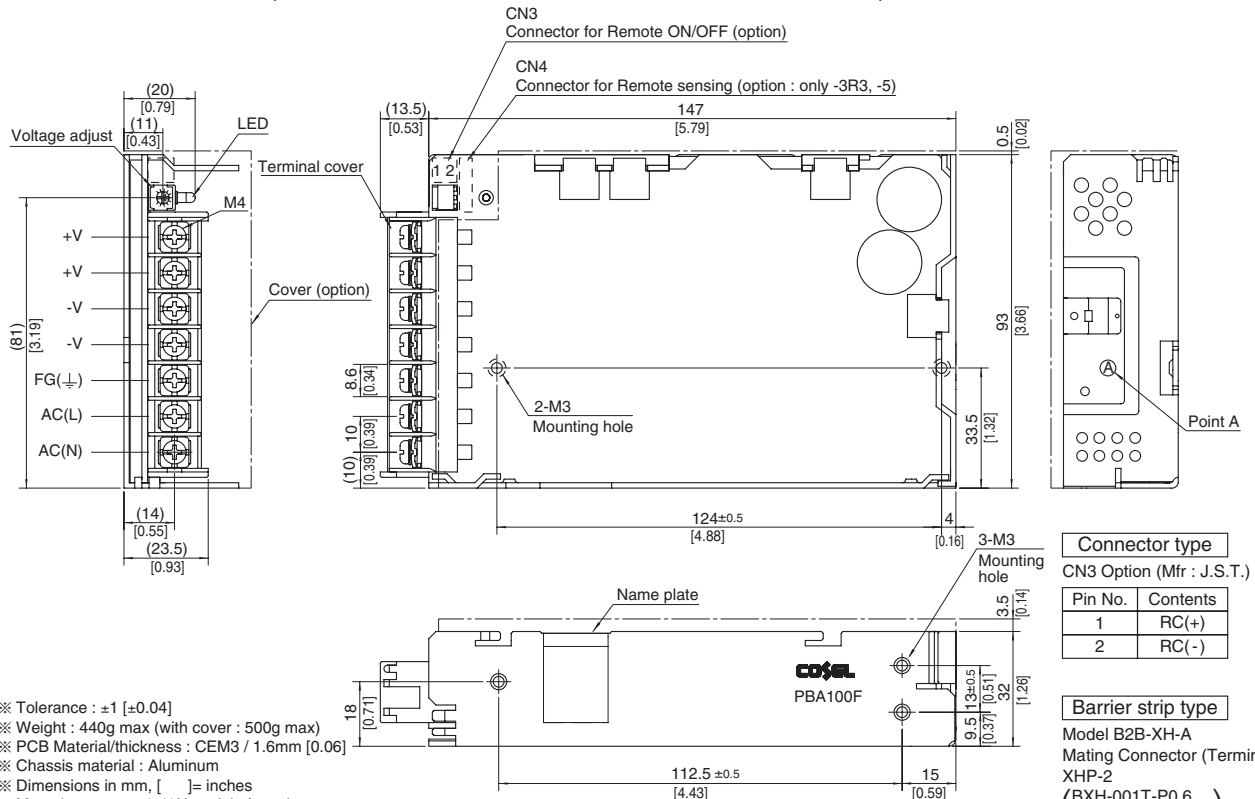

- ※ Tolerance : ±1 [±0.04]
- ※ Weight : 440g max (with cover : 500g max)
- ※ PCB Material/thickness : CEM3 / 1.6mm [0.06]
- ※ Chassis material : Aluminum
- ※ Dimensions in mm, [] = inches
- ※ Mounting torque : 0.49N • m(5kgf • cm)max
- ※ Mounting torque : M4:1.6N • m(16.9kgf • cm)max
- ※ Please connect safety ground to FG terminal on the unit.

PBA150F

PB A 150 F -5 -□

① ② ③ ④ ⑤ ⑥

PBA/PBW



RoHS

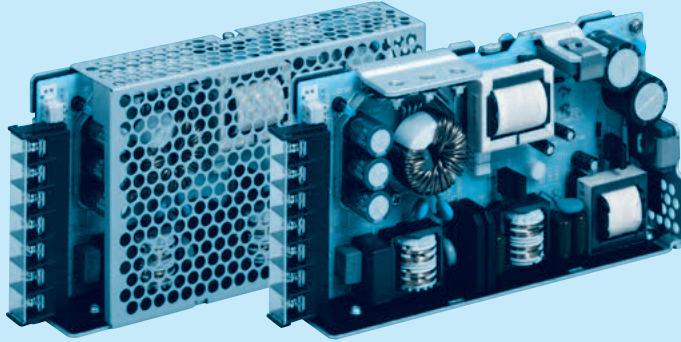

Example recommended EMI/EMC filter
NAC-06-472



High voltage pulse noise type : NAP series
Low leakage current type : NAM series
* A higher current rating EMI/EMC filter may be recommended in view of the other devices that could be connected in parallel with the power supply.

- ① Series name
- ② Single output
- ③ Output wattage
- ④ Universal input
- ⑤ Output voltage
- ⑥ Optional *5
- C :with Coating
- G :Low leakage current (0.15mA max / ACIN 240V)
- E :Low leakage current and EMI class A (0.5mA max / ACIN 240V)
- T :Vertical terminal block
- J1 :VH (J.S.T.) connector type (Only -12,-15,-24,-36,-48)
- R :with Remote ON/OFF
- N :with Cover (Only 24V UL508 is acquired)
- NI :with DIN rail and Cover
- V :Output voltage setting potentiometer external-ly

Cover is optional

* Make sure necessary tests will be carried out on your end equipment with the power supply installed in accordance with any required EMC/EMI regulations.

MODEL	PBA150F-3R3	PBA150F-5	PBA150F-9	PBA150F-12	PBA150F-15	PBA150F-24	PBA150F-36	PBA150F-48
MAX OUTPUT WATTAGE[W]	99	150	150.3	156	150	156	154.8	158.4
DC OUTPUT	3.3V 30A	5V 30A	9V 16.7A	12V 13A	15V 10A	24V 6.5A	36V 4.3A	48V 3.3A

SPECIFICATIONS

	MODEL	PBA150F-3R3	PBA150F-5	PBA150F-9	PBA150F-12	PBA150F-15	PBA150F-24	PBA150F-36	PBA150F-48	
INPUT	VOLTAGE[V]	AC85 - 264 1 φ or DC120 - 370 (AC50 or DC70 Please refer to the instruction manual 1.1 Input voltage *4)								
	CURRENT[A]	ACIN 100V	1.3typ	2.0typ						
		ACIN 200V	0.7typ	1.0typ						
	FREQUENCY[Hz]	50/60 (47 - 63)								
	EFFICIENCY[%]	ACIN 100V	80typ	83typ	82typ	83typ	84typ	85typ	85typ	85typ
		ACIN 200V	82typ	86typ	85typ	86typ	87typ	88typ	88typ	88typ
	POWER FACTOR(lo=100%)	ACIN 100V	0.98typ	0.99typ						
		ACIN 200V	0.87typ	0.93typ						
	INRUSH CURRENT[A]	ACIN 100V	20typ (lo=100%) (At cold start)							
		ACIN 200V	40typ (lo=100%) (At cold start)							
LEAKAGE CURRENT[mA]	0.4/0.75max (ACIN 100V/240V 60Hz, lo=100%, According to IEC62368-1.DENAN)									
OUTPUT	VOLTAGE[V]	3.3	5	9	12	15	24	36	48	
	CURRENT[A]	30	30	16.7	13	10	6.5	4.3	3.3	
	LINE REGULATION[mV]	20max	20max	36max	48max	60max	96max	144max	192max	
	LOAD REGULATION[mV]	40max	40max	100max	100max	120max	150max	240max	240max	
	RIPPLE[mVp-p]	0 to +50°C *1	80max	80max	120max	120max	120max	120max	150max	150max
		-10 - 0°C *1	140max	140max	160max	160max	160max	160max	200max	200max
	RIPPLE NOISE[mVp-p]	0 to +50°C *1	120max	120max	150max	150max	150max	150max	250max	250max
		-10 - 0°C *1	160max	160max	180max	180max	180max	180max	300max	300max
	TEMPERATURE REGULATION[mV]	0 to +50°C	50max	50max	90max	120max	150max	240max	360max	480max
		-10 to +50°C	60max	60max	120max	150max	180max	290max	450max	600max
	DRIFT[mV]	*2	20max	20max	36max	48max	60max	96max	144max	192max
	START-UP TIME[ms]	350typ(ACIN 100V, lo=100%)								
	HOLD-UP TIME[ms]	20typ (ACIN 100V, lo=100%)								
	OUTPUT VOLTAGE ADJUSTMENT RANGE[V]	2.85 - 3.63	4.00 - 5.50	7.50 - 10.0	10.0 - 13.2	13.2 - 18.0	19.2 - 27.0	28.8 - 39.6	39.0 - 53.0	
	OUTPUT VOLTAGE SETTING[V]	3.30 - 3.40	5.00 - 5.15	9.00 - 9.36	12.00 - 12.48	15.00 - 15.60	24.00 - 24.96	36.00 - 37.44	48.00 - 49.92	
PROTECTION CIRCUIT AND OTHERS	OVERCURRENT PROTECTION	Works over 105% of rated current and recovers automatically								
	OVERVOLTAGE PROTECTION[V]	4.00 - 5.25	5.75 - 7.00	11.5 - 14.0	15.0 - 18.0	20.0 - 25.0	30.0 - 37.0	43.0 - 50.0	58.0 - 65.0	
	OPERATING INDICATION	LED (Green)								
	REMOTE SENSING	Optional (Only -3R3, -5 Option -K)								
ISOLATION	REMOTE ON/OFF	Optional (Required external power source)								
	INPUT-OUTPUT · RC	*3	AC3,000V 1minute, Cutoff current = 10mA, DC500V 50MΩmin (At Room Temperature)							
	INPUT-FG	*3	AC2,000V 1minute, Cutoff current = 10mA, DC500V 50MΩmin (At Room Temperature)							
ENVIRONMENT	OUTPUT · RC-FG	*3	AC500V 1minute, Cutoff current = 100mA, DC500V 50MΩmin (At Room Temperature)							
	OPERATING TEMP.,HUMID.AND ALTITUDE	-10 to +71°C (Refer to "Derating"), 20 - 90%RH (Non condensing) 3,000m (10,000feet) max								
	STORAGE TEMP.,HUMID.AND ALTITUDE	-20 to +75°C, 20 - 90%RH (Non condensing) 9,000m (30,000feet) max								
SAFETY AND NOISE REGULATIONS	VIBRATION	10 - 55Hz, 19.6m/s ² (2G), 3minutes period, 60minutes each along X, Y and Z axis								
	IMPACT	196.1m/s ² (20G), 11ms, once each X, Y and Z axis								
	AGENCY APPROVALS (At only AC input)	UL60950-1, C-UL(CSA60950-1), EN62368-1 Complies with DEN-AN								
OTHERS	CONDUCTED NOISE	Complies with FCC Part15 classB, VCCI-B, CISPR22-B, EN55011-B, EN55022-B								
	HARMONIC ATTENUATOR	Complies with IEC61000-3-2 *6								
OTHERS	CASE SIZE/WEIGHT	34 x 93 x 168mm [1.34 x 3.66 x 6.61 inches] (without terminal block) (W x H x D) / 560g max (with cover : 630g max)								
	COOLING METHOD	Convection								

*1 Measured by 20MHz oscilloscope or Ripple-Noise meter(equivalent to KEISOKU-GIKEN :RM101).
 *2 Drift is the change in DC output for an eight hour period after a half-hour warm-up at 25°C.
 *3 Applicable when Remote ON/OFF(optional) is added. RC is insulated with input, output and FG.
 *4 Derating is required.

*5 Please contact us about safety approvals for the model with option.
 *6 Please contact us about class C.
 * Parallel operation with other model is not possible.
 * Derating is required when operated with cover.
 * A sound may occur from power supply at peak loading.

Block diagram

PBA/PBW

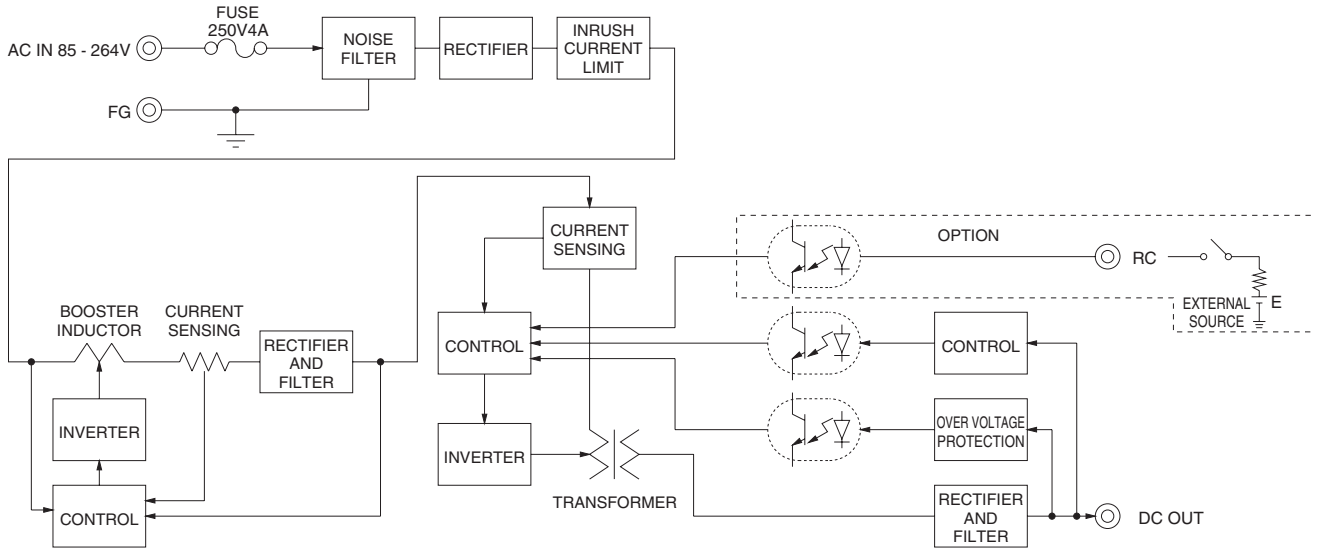

External view

※ External size of option T, J1, R, N1, V and K is different from standard model and refer to 7 Option of instruction manual for details.

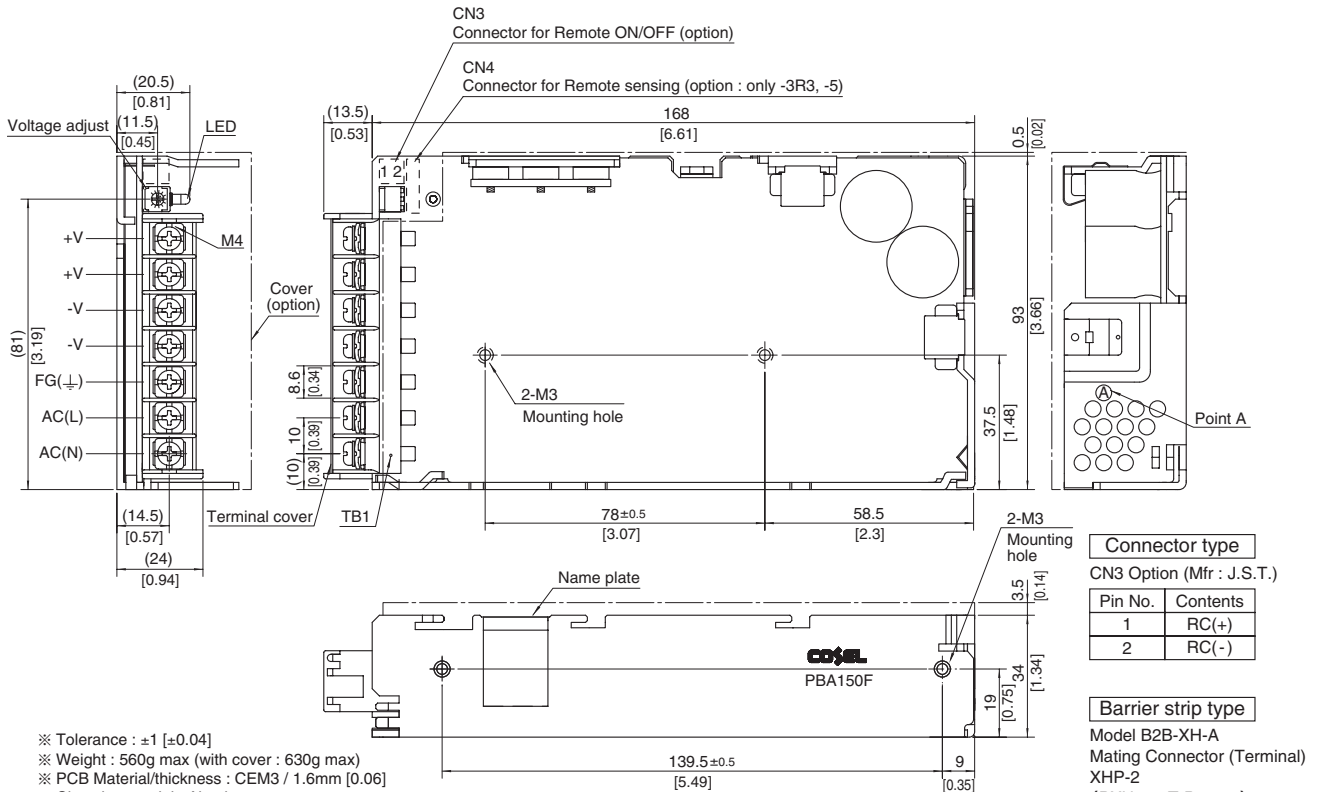

- ※ Tolerance : ± 1 [± 0.04]
- ※ Weight : 560g max (with cover : 630g max)
- ※ PCB Material/thickness : CEM3 / 1.6mm [0.06]
- ※ Chassis material : Aluminum
- ※ Dimensions in mm, [] = inches
- ※ Mounting torque : $0.49\text{N} \cdot \text{m}$ (5kgf \cdot cm) max
- ※ Mounting torque : M4: $1.6\text{N} \cdot \text{m}$ (16.9kgf \cdot cm) max
- ※ Keep drawing current per pin below 20A for TB1.
- ※ Please connect safety ground to FG terminal on the unit.

PBA300F

PB A 300 F -5 -□

① ② ③ ④ ⑤ ⑥

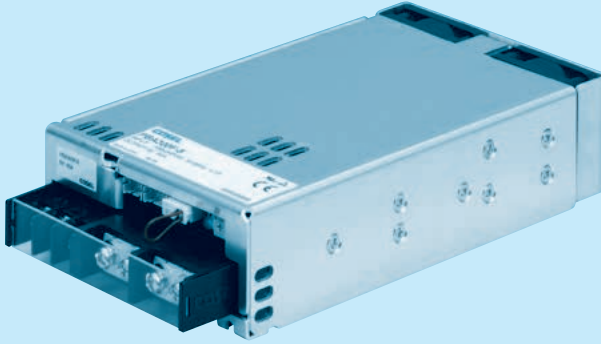
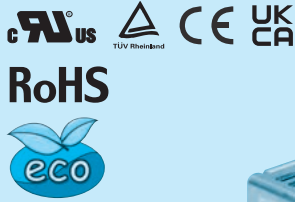

Example recommended EMI/EMC filter
NAC-06-472



High voltage pulse noise type : NAP series
Low leakage current type : NAM series
* A higher current rating EMI/EMC filter may be recommended in view of the other devices that could be connected in parallel with the power supply.

- ① Series name
- ② Single output
- ③ Output wattage
- ④ Universal input
- ⑤ Output voltage
- ⑥ Optional *5
- C :with Coating
- G :Low leakage current
- U :Operation stop voltage is set at a lower value
- F3 :Reverse air exhaust type
- F4 :Low speed fan
- N1 :with DIN rail

Refer to instruction manual 7.1.

*Make sure necessary tests will be carried out on your end equipment with the power supply installed in accordance with any required EMC/EMI regulations.

MODEL	PBA300F-3R3	PBA300F-5	PBA300F-7R5	PBA300F-12	PBA300F-15	PBA300F-24	PBA300F-36	PBA300F-48
MAX OUTPUT WATTAGE[W]	198	300	300	324	330	336	324	336
DC OUTPUT	ACIN 100V	3.3V 60A	5V 60A	7.5V 40A	12V 27A	15V 22A	24V 14A	36V 9A
	ACIN 200V *3	3.3V 60A	5V 60A	7.5V 40A	12V 27A	15V 22A	24V 14(16.5)A	36V 9A

SPECIFICATIONS

MODEL	PBA300F-3R3	PBA300F-5	PBA300F-7R5	PBA300F-12	PBA300F-15	PBA300F-24	PBA300F-36	PBA300F-48		
INPUT	VOLTAGE[V]	AC85 - 264 1φ or DC120 - 350 (AC50 or DC70 Please refer to the instruction manual 7. option *4)								
	CURRENT[A]	ACIN 100V	3typ	4.1typ						
		ACIN 200V	1.6typ	2typ						
	FREQUENCY[Hz]	50/60 (47 - 63)								
	EFFICIENCY[%]	ACIN 100V	68typ	74typ	76typ	78typ	78typ	79typ	81typ	
		ACIN 200V	71typ	77typ	79typ	81typ	81typ	82typ	84typ	
	POWER FACTOR	ACIN 100V	0.98typ (Io=100%)							
		ACIN 200V	0.95typ (Io=100%)							
	INRUSH CURRENT[A]	ACIN 100V	20/40typ (Io=100%) (Primary inrush current /Secondary inrush current) (More then 3 sec. to re-start)							
		ACIN 200V	40/40typ (Io=100%) (Primary inrush current /Secondary inrush current) (More then 3 sec. to re-start)							
LEAKAGE CURRENT[mA]	0.45/0.75max (ACIN 100V/240V 60Hz, Io=100%, According to IEC62368-1.DENAN)									
OUTPUT	VOLTAGE[V]	3.3	5	7.5	12	15	24	36	48	
	CURRENT[A]	ACIN 100V	60	60	40	27	22	14	9	7
		ACIN 200V *3	60	60	40	27	22	14(16.5)	9	7
	LINE REGULATION[mV]	20max	20max	36max	48max	60max	96max	144max	192max	
	LOAD REGULATION[mV]	40max	40max	60max	100max	120max	150max	150max	300max	
	RIPPLE[mVp-p]	0 to +50°C *1	80max	80max	120max	120max	120max	120max	150max	150max
		-20 - 0°C *1	140max	140max	160max	160max	160max	160max	160max	400max
	RIPPLE NOISE[mVp-p]	0 to +50°C *1	120max	120max	150max	150max	150max	150max	200max	200max
		-20 - 0°C *1	160max	160max	180max	180max	180max	180max	240max	500max
	TEMPERATURE REGULATION[mV]	0 to +50°C	40max	50max	75max	120max	150max	240max	360max	480max
-20 to +50°C		60max	75max	120max	180max	180max	290max	440max	600max	
DRIFT [mV]	*2	12max	20max	30max	48max	60max	96max	144max	192max	
START-UP TIME[ms]	300typ(ACIN 100/200V, Io=100%) *Start-up time is 500ms typ for less than 1minute of applying input again from turning off the input voltage.									
HOLD-UP TIME[ms]	20typ (ACIN 100/200V, Io=100%)									
OUTPUT VOLTAGE ADJUSTMENT RANGE[V]	2.64 - 3.96	3.96 - 6.00	5.25 - 8.25	8.25 - 13.20	10.50 - 16.50	16.50 - 26.40	25.20 - 39.60	38.40 - 56.00		
OUTPUT VOLTAGE SETTING[V]	3.30 - 3.40	5.00 - 5.15	7.50 - 7.80	12.00 - 12.48	15.00 - 15.60	24.00 - 24.96	36.00 - 37.44	48.00 - 49.92		
PROTECTION CIRCUIT AND OTHERS	OVERCURRENT PROTECTION	Works over 105% of rated current or 101% of peak current and recovers automatically								
	OVERVOLTAGE PROTECTION[V]	4.3 - 6.3	6.5 - 8.0	9.0 - 11.6	14.4 - 18.6	18.0 - 23.3	28.8 - 37.2	43.2 - 54.0	57.6 - 80.0	
	OPERATING INDICATION	LED (Green)								
	REMOTE SENSING	Provided								
	REMOTE ON/OFF	Provided								
ISOLATION	INPUT-OUTPUT · RC	AC3.000V 1minute, Cutoff current = 10mA, DC500V 50MΩmin (At Room Temperature)								
	INPUT-FG	AC2.000V 1minute, Cutoff current = 10mA, DC500V 50MΩmin (At Room Temperature)								
	OUTPUT · RC · AUX-FG	AC500V 1minute, Cutoff current = 100mA, DC500V 50MΩmin (At Room Temperature)								
	OUTPUT-RC · AUX	AC500V 1minute, Cutoff current = 100mA, DC500V 50MΩmin (At Room Temperature)								
ENVIRONMENT	OPERATING TEMP.,HUMID.AND ALTITUDE	-20 to +71°C (Refer to "Derating"), 20 - 90%RH (Non condensing) 3,000m (10,000feet) max								
	STORAGE TEMP.,HUMID.AND ALTITUDE	-20 to +75°C, 20 - 90%RH (Non condensing) 9,000m (30,000feet) max								
	VIBRATION	10 - 55Hz, 19.6m/s ² (2G), 3minutes period, 60minutes each along X, Y and Z axis								
IMPACT	196.1m/s ² (20G), 11ms, once each X, Y and Z axis									
SAFETY AND NOISE REGULATIONS	AGENCY APPROVALS (At only AC input)	UL60950-1, C-UL(CSA60950-1), EN62368-1 Complies with DEN-AN								
	CONDUCTED NOISE	Complies with FCC Part15 classB, VCCI-B, CISPR22-B, EN55011-B, EN55022-B								
	HARMONIC ATTENUATOR	Complies with IEC61000-3-2 *6								
OTHERS	CASE SIZE/WEIGHT	102 X 42 X 170mm [4.02 X 1.65 X 6.69 inches] (without terminal block and screw) (W X H X D) /1.0kg max								
	COOLING METHOD	Forced cooling (internal fan)								

*1 Measured by 20MHz oscilloscope or Ripple-Noise meter(equivalent to KEISOKU-GIKEN :RM101).
 *2 Drift is the change in DC output for an eight hour period after a half-hour warm-up at 25°C.
 *3 () means peak current. Peak loading for 10s. And Duty 35% max, refer to Instruction manual in detail.
 *4 Derating is required.Consult us for details.

*5 Please contact us about safety approvals for the model with option.
 *6 Please contact us about class C.
 * A sound may occur from power supply at pulse loading.

Block diagram

PBA/PBW

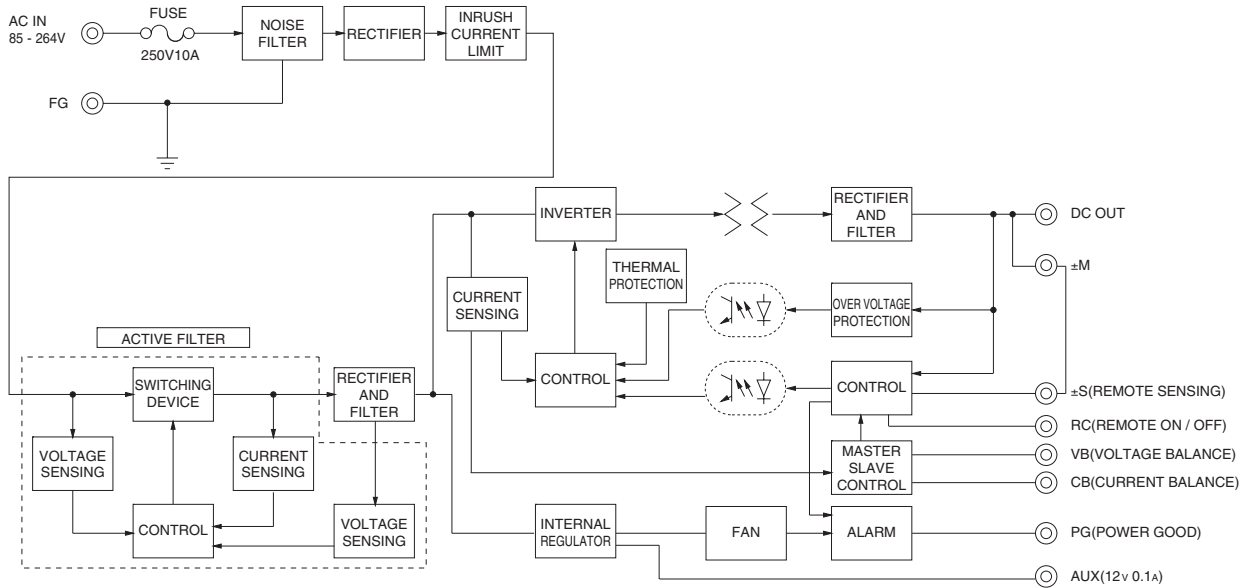

External view

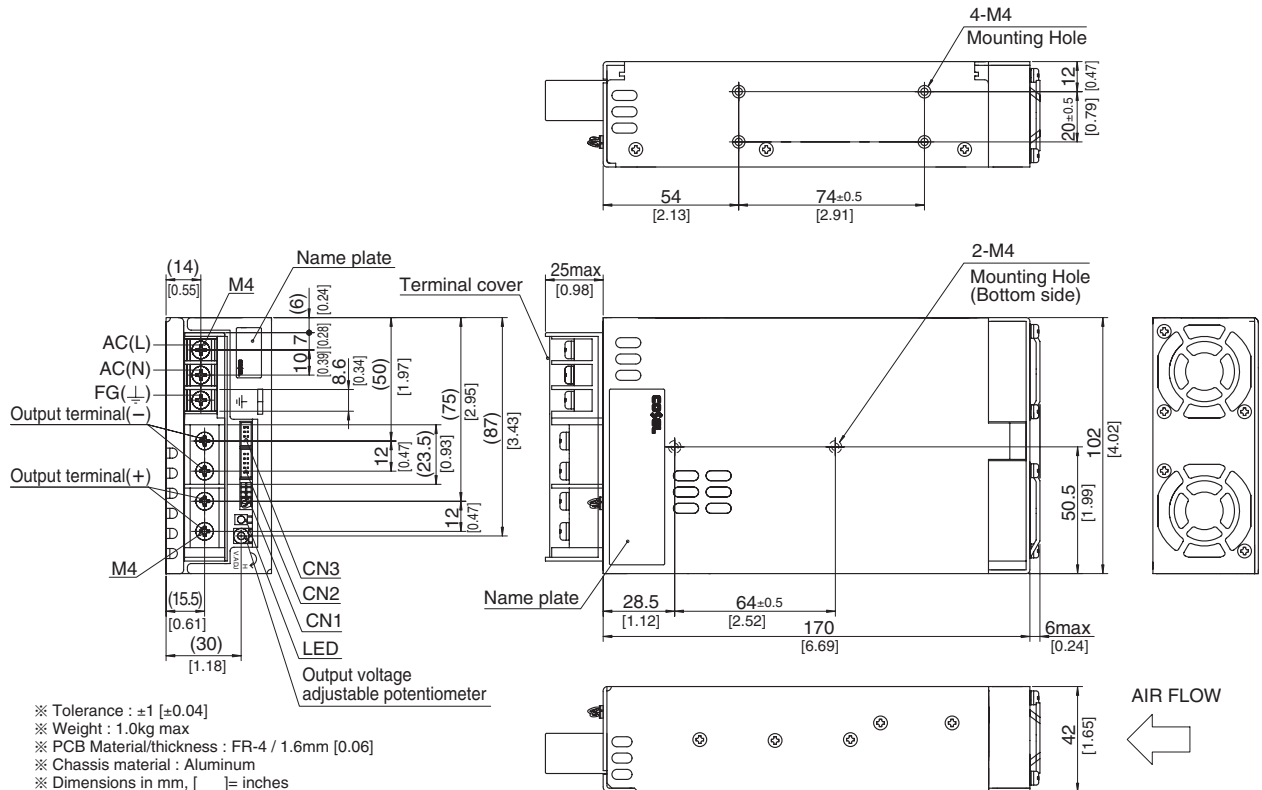

- ※ Tolerance : ±1 [±0.04]
- ※ Weight : 1.0kg max
- ※ PCB Material/thickness : FR-4 / 1.6mm [0.06]
- ※ Chassis material : Aluminum
- ※ Dimensions in mm, [] = inches
- ※ Mounting torque : 1.2N · m max
- ※ Screw tightening torque : 1.6N · m max
- ※ The housing for the remote sensing unused is mounted on CN1
- ※ Please connect safety ground to FG terminal on the unit.

PBA600F

PB A 600 F -5 -□

① ② ③ ④ ⑤ ⑥

PBA/PBW

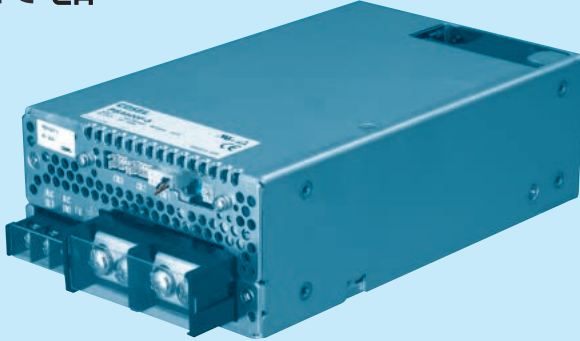
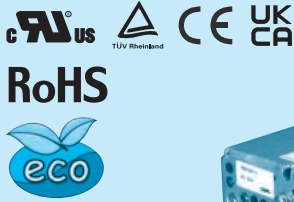

Example recommended EMI/EMC filter
NAC-16-472



High voltage pulse noise type : NAP series
Low leakage current type : NAM series
* A higher current rating EMI/EMC filter may be recommended in view of the other devices that could be connected in parallel with the power supply.

- ① Series name
- ② Single output
- ③ Output wattage
- ④ Universal input
- ⑤ Output voltage
- ⑥ Optional *6
- C :with Coating
- G :Low leakage current
- U :Operation stop voltage is set at a lower value
- F1 :With Long-Life fan
- F3 :Reverse air exhaust type
- F4 :Low speed fan

Refer to instruction manual 7.1.

*Make sure necessary tests will be carried out on your end equipment with the power supply installed in accordance with any required EMC/EMI regulations.

MODEL	PBA600F-3R3	PBA600F-5	PBA600F-7R5	PBA600F-12	PBA600F-15	PBA600F-24	PBA600F-36	PBA600F-48
MAX OUTPUT WATTAGE[W]	396	600	600	636	645	648	648	624
DC OUTPUT	ACIN 100V	3.3V 120A	5V 120A	7.5V 80A	12V 53A	15V 43A	24V 27A	36V 18A
	ACIN 200V *3	3.3V 120A	5V 120A	7.5V 80A	12V 53A	15V 43A	24V 27(31)A	36V 18A

SPECIFICATIONS

	MODEL	PBA600F-3R3	PBA600F-5	PBA600F-7R5	PBA600F-12	PBA600F-15	PBA600F-24	PBA600F-36	PBA600F-48	
INPUT	VOLTAGE[V]	AC85 - 264 1φ or DC120 - 350 (AC50 or DC70 Please refer to the instruction manual 7. option *5)								
	CURRENT[A]	ACIN 100V	5.8typ	8.2typ						
		ACIN 200V	3typ	4.1typ						
	FREQUENCY[Hz]	50/60 (47 - 63)								
	EFFICIENCY[%]	ACIN 100V	70typ	75typ	76typ	79typ	79typ	81typ	82typ	81typ
		ACIN 200V	72typ	77typ	79typ	82typ	82typ	84typ	84typ	83typ
	POWER FACTOR	ACIN 100V	0.98typ (Io=100%)							
ACIN 200V		0.95typ (Io=100%)								
INRUSH CURRENT[A]	ACIN 100V	20/40typ (Io=100%) (Primary inrush current /Secondary inrush current) (More than 3 sec. to re-start)								
	ACIN 200V	40/40typ (Io=100%) (Primary inrush current /Secondary inrush current) (More than 3 sec. to re-start)								
LEAKAGE CURRENT[mA]	0.45/0.75max (ACIN 100V/240V 60Hz, Io=100%, According to IEC62368-1, DENAN)									
OUTPUT	VOLTAGE[V]	3.3	5	7.5	12	15	24	36	48	
	CURRENT[A]	ACIN 100V	120	120	80	53	43	27	18	13
		ACIN 200V *3	120	120	80	53	43	27(31)	18	13
	LINE REGULATION[mV]	20max	20max	36max	48max	60max	96max	144max	192max	
	LOAD REGULATION[mV]	40max	40max	60max	100max	120max	150max	150max	300max	
	RIPPLE[mVp-p]	0 to +50°C *1	80max	80max	120max	120max	120max	120max	150max	150max
		-20 - 0°C *1	140max	140max	160max	160max	160max	160max	160max	400max
	RIPPLE NOISE[mVp-p]	0 to +50°C *1	120max	120max	150max	150max	150max	150max	200max	200max
		-20 - 0°C *1	160max	160max	180max	180max	180max	180max	240max	500max
	TEMPERATURE REGULATION[mV]	0 to +50°C	40max	50max	75max	120max	150max	240max	360max	480max
-20 to +50°C		60max	75max	120max	180max	180max	290max	440max	600max	
DRIFT[mV]	*2	12max	20max	30max	48max	60max	96max	144max	192max	
START-UP TIME[ms]	400typ(ACIN 100/200V, Io=100%) *Start-up time is 500ms typ for less than 1minute of applying input again from turning off the input voltage.									
HOLD-UP TIME[ms]	20typ (ACIN 100/200V, Io=100%)									
OUTPUT VOLTAGE ADJUSTMENT RANGE[V]	2.64 - 3.96	3.96 - 6.00	5.25 - 8.25	8.25 - 13.20	10.50 - 16.50	16.50 - 26.40	25.20 - 39.60	38.40 - 56.00		
OUTPUT VOLTAGE SETTING[V]	3.30 - 3.40	5.00 - 5.15	7.50 - 7.80	12.00 - 12.48	15.00 - 15.60	24.00 - 24.96	36.00 - 37.44	48.00 - 49.92		
PROTECTION CIRCUIT AND OTHERS	OVERCURRENT PROTECTION	Works over 105% of rated current or 101% of peak current and recovers automatically								
	OVERVOLTAGE PROTECTION[V] *4	Vo+0.66 - 1.32	Vo+1.0 - 2.0	Vo+1.5 - 3.0	Vo+2.4 - 4.8	Vo+3.0 - 6.0	Vo+4.8 - 9.6	Vo+7.2 - 14.4	Vo+4.8 - 12.0	
	OPERATING INDICATION	LED (Green)								
	REMOTE SENSING	Provided								
REMOTE ON/OFF	Provided									
ISOLATION	INPUT-OUTPUT · RC	AC3.000V 1minute, Cutoff current = 10mA, DC500V 50MΩmin (At Room Temperature)								
	INPUT-FG	AC2.000V 1minute, Cutoff current = 10mA, DC500V 50MΩmin (At Room Temperature)								
	OUTPUT · RC · AUX-FG	AC500V 1minute, Cutoff current = 100mA, DC500V 50MΩmin (At Room Temperature)								
	OUTPUT-RC · AUX	AC500V 1minute, Cutoff current = 100mA, DC500V 50MΩmin (At Room Temperature)								
ENVIRONMENT	OPERATING TEMP.,HUMID.AND ALTITUDE	-20 to +71°C (Refer to "Derating"), 20 - 90%RH (Non condensing) 3,000m (10,000feet) max								
	STORAGE TEMP.,HUMID.AND ALTITUDE	-20 to +75°C, 20 - 90%RH (Non condensing) 9,000m (30,000feet) max								
	VIBRATION	10 - 55Hz, 19.6m/s ² (2G), 3minutes period, 60minutes each along X, Y and Z axis								
IMPACT	196.1m/s ² (20G), 11ms, once each X, Y and Z axis									
SAFETY AND NOISE REGULATIONS	AGENCY APPROVALS (At only AC input)	UL60950-1, C-UL(CSA60950-1), EN62368-1 Complies with DEN-AN								
	CONDUCTED NOISE	Complies with FCC Part15 classB, VCCI-B, CISPR22-B, EN55011-B, EN55022-B								
	HARMONIC ATTENUATOR	Complies with IEC61000-3-2 *7								
OTHERS	CASE SIZE/WEIGHT	120×61×190mm [4.72×2.4×7.48 inches] (without terminal block and screw) (W×H×D) /1.6kg max								
	COOLING METHOD	Forced cooling (internal fan)								

*1 Measured by 20MHz oscilloscope or Ripple-Noise meter(equivalent to KEISOKU-GIKEN :RM101).
 *2 Drift is the change in DC output for an eight hour period after a half-hour warm-up at 25°C.
 *3 () means peak current. Peak loading for 10s. And Duty 35% max, refer to Instruction manual in detail.
 *4 Overvoltage protection circuit to follow to output voltage setting. Standard overvoltage protection circuit is please contact us for details.

*5 Derating is required.Consult us for details.
 *6 Please contact us about safety approvals for the model with option.
 *7 Please contact us about class C.
 * A sound may occur from power supply at pulse loading.

Block diagram

PBA/PBW

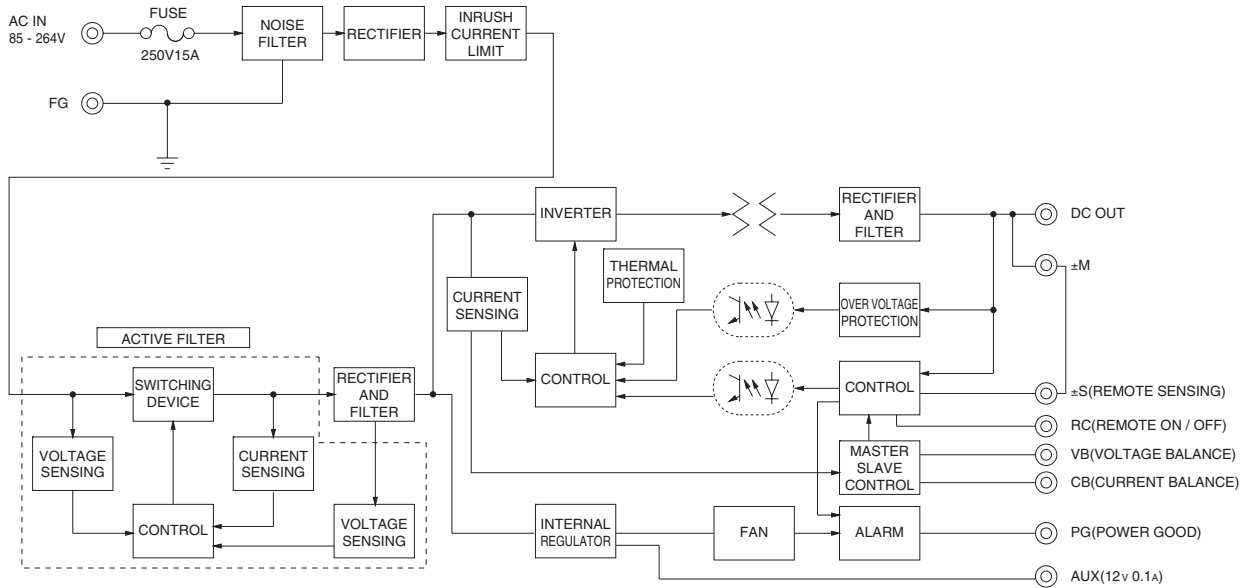

External view

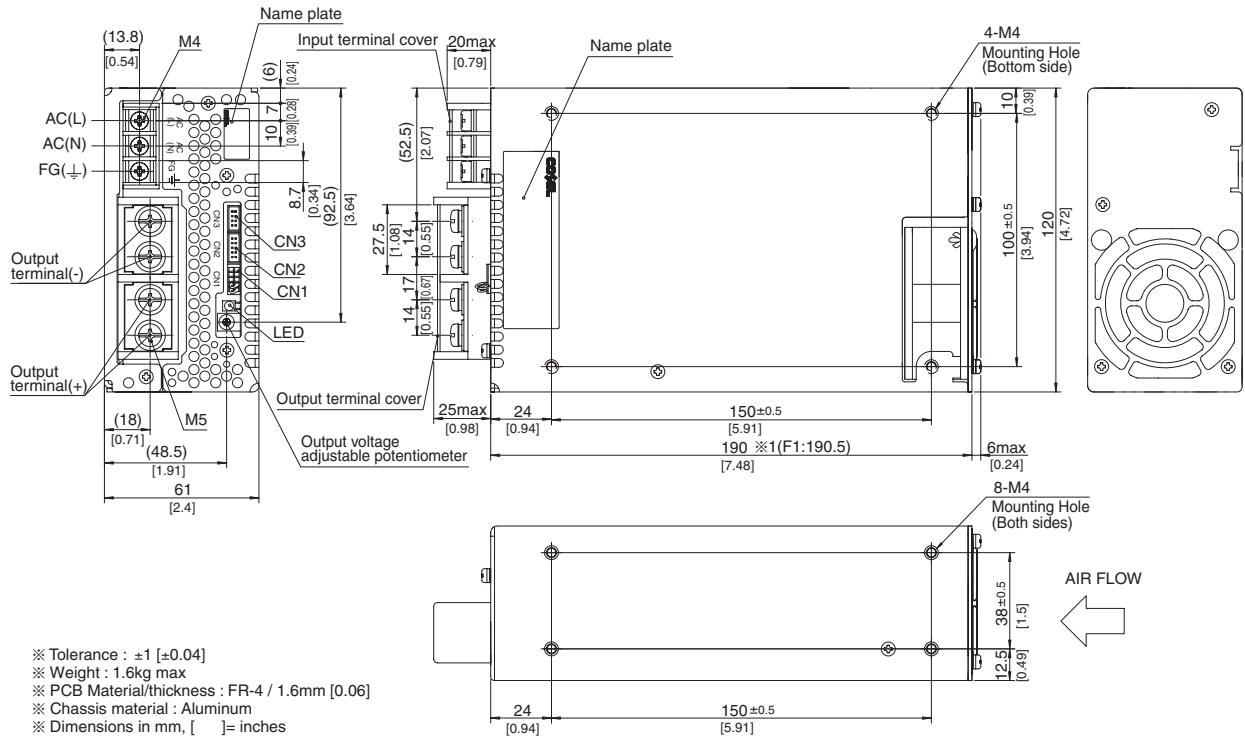

- ※ Tolerance : ±1 [±0.04]
- ※ Weight : 1.6kg max
- ※ PCB Material/thickness : FR-4 / 1.6mm [0.06]
- ※ Chassis material : Aluminum
- ※ Dimensions in mm, [] = inches
- ※ Mounting torque : 1.2N · m (12.8kgf · cm) max
- ※ Screw tightening torque : M4 1.6N · m (16.9kgf · cm) max
M5 2.5N · m (24.5kgf · cm) max
- ※ The housing for the remote sensing unused is mounted on CN1
- ※ 1 F1(Optional):190.5
- ※ Please connect safety ground to FG terminal on the unit.

PBA1000F

PB A 1000 F -5 -□

① ② ③ ④ ⑤ ⑥

PBA/PBW

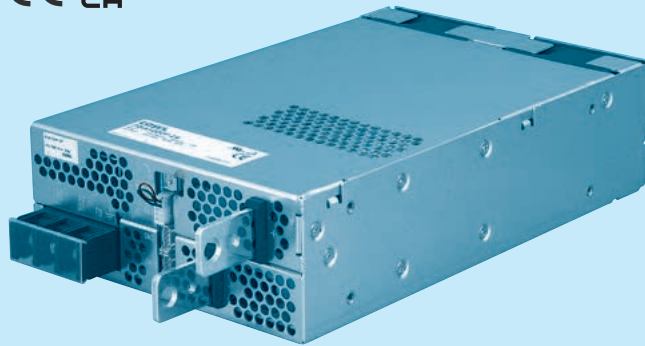
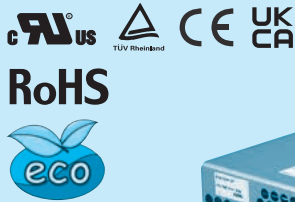

Example recommended EMI/EMC filter
NAC-20-472



High voltage pulse noise type : NAP series
Low leakage current type : NAM series
* A higher current rating EMI/EMC filter may be recommended in view of the other devices that could be connected in parallel with the power supply.

- ① Series name
- ② Single output
- ③ Output wattage
- ④ Universal input
- ⑤ Output voltage
- ⑥ Optional *6
- C :with Coating
- G :Low leakage current
- U :Operation stop voltage is set at a lower value
- F1 :With Long-Life fan
- F3 :Reverse air exhaust type
- F4 :Low speed fan

Refer to instruction manual 7.1.

*Make sure necessary tests will be carried out on your end equipment with the power supply installed in accordance with any required EMC/EMI regulations.

MODEL	PBA1000F-3R3	PBA1000F-5	PBA1000F-7R5	PBA1000F-12	PBA1000F-15	PBA1000F-24	PBA1000F-36	PBA1000F-48	
MAX OUTPUT WATTAGE[W]	660	1000	1005	1056	1050	1056	1044	1056	
DC OUTPUT	ACIN 100V	3.3V 200A	5V 200A	7.5V 134A	12V 88A	15V 70A	24V 44A	36V 29A	48V 22A
	ACIN 200V *3	3.3V 200A	5V 200A	7.5V 134A	12V 88A	15V 70A	24V 44(51)A	36V 29A	48V 22A

SPECIFICATIONS

	MODEL	PBA1000F-3R3	PBA1000F-5	PBA1000F-7R5	PBA1000F-12	PBA1000F-15	PBA1000F-24	PBA1000F-36	PBA1000F-48	
INPUT	VOLTAGE[V]	AC85 - 264 1 φ or DC120 - 350 (AC50 or DC70 Please refer to the instruction manual 7. option *5)								
	CURRENT[A]	ACIN 100V	9typ	13typ						
		ACIN 200V	5typ	7typ						
	FREQUENCY[Hz]	50/60 (47 - 63)								
	EFFICIENCY[%]	ACIN 100V	74typ	79typ	80typ	82typ	82typ	84typ	84typ	84typ
		ACIN 200V	76typ	81typ	83typ	84typ	84typ	86typ	86typ	86typ
	POWER FACTOR	ACIN 100V	0.98typ (Io=100%)							
ACIN 200V		0.95typ (Io=100%)								
INRUSH CURRENT[A]	ACIN 100V	20/40typ (Io=100%) (Primary inrush current /Secondary inrush current) (More than 10 sec. to re-start)								
	ACIN 200V	40/40typ (Io=100%) (Primary inrush current /Secondary inrush current) (More than 10 sec. to re-start)								
LEAKAGE CURRENT[mA]	0.5/1.0max (ACIN 100V/240V 60Hz, Io=100%, According to IEC62368-1, DENAN)									
OUTPUT	VOLTAGE[V]	3.3	5	7.5	12	15	24	36	48	
	CURRENT[A]	ACIN 100V	200	200	134	88	70	44	29	22
		ACIN 200V *3	200	200	134	88	70	44(51)	29	22
	LINE REGULATION[mV]	20max	20max	36max	48max	60max	96max	144max	192max	
	LOAD REGULATION[mV]	40max	40max	60max	100max	120max	150max	150max	300max	
	RIPPLE[mVp-p]	0 to +50°C *1	80max	80max	120max	120max	120max	120max	150max	150max
		-20 - 0°C *1	140max	140max	160max	160max	160max	160max	160max	400max
	RIPPLE NOISE[mVp-p]	0 to +50°C *1	120max	120max	150max	150max	150max	150max	200max	200max
		-20 - 0°C *1	160max	160max	180max	180max	180max	180max	240max	500max
	TEMPERATURE REGULATION[mV]	0 to +50°C	40max	50max	75max	120max	150max	240max	360max	480max
		-20 to +50°C	60max	75max	120max	180max	180max	290max	440max	600max
	DRIFT[mV]	*2	12max	20max	30max	48max	60max	96max	144max	192max
START-UP TIME[ms]	400typ(ACIN 100/200V, Io=100%) *Start-up time is 500ms typ for less than 1minute of applying input again from turning off the input voltage.									
HOLD-UP TIME[ms]	20typ (ACIN 100/200V, Io=100%)									
OUTPUT VOLTAGE ADJUSTMENT RANGE[V]	2.64 - 3.96	3.96 - 6.00	5.25 - 8.25	8.25 - 13.20	10.50 - 16.50	16.50 - 26.40	25.20 - 39.60	38.40 - 56.00		
OUTPUT VOLTAGE SETTING[V]	3.30 - 3.40	5.00 - 5.15	7.50 - 7.80	12.00 - 12.48	15.00 - 15.60	24.00 - 24.96	36.00 - 37.44	48.00 - 49.92		
PROTECTION CIRCUIT AND OTHERS	OVERCURRENT PROTECTION	Works over 105% of rated current or 101% of peak current and recovers automatically								
	OVERVOLTAGE PROTECTION[V] *4	Vo+0.66 - 1.32	Vo+1.0 - 2.0	Vo+1.5 - 3.0	Vo+2.4 - 4.8	Vo+3.0 - 6.0	Vo+4.8 - 9.6	Vo+7.2 - 14.4	Vo+4.8 - 12.0	
	OPERATING INDICATION	LED (Green)								
	REMOTE SENSING	Provided								
ISOLATION	REMOTE ON/OFF	Provided								
	INPUT-OUTPUT · RC	AC3.000V 1minute, Cutoff current = 25mA, DC500V 50MΩmin (At Room Temperature)								
	INPUT-FG	AC2.000V 1minute, Cutoff current = 25mA, DC500V 50MΩmin (At Room Temperature)								
	OUTPUT · RC · AUX-FG	AC500V 1minute, Cutoff current = 100mA, DC500V 50MΩmin (At Room Temperature)								
ENVIRONMENT	OUTPUT-RC · AUX	AC500V 1minute, Cutoff current = 100mA, DC500V 50MΩmin (At Room Temperature)								
	OPERATING TEMP.,HUMID.AND ALTITUDE	-20 to +71°C (Refer to "Derating"), 20 - 90%RH (Non condensing) 3,000m (10,000feet) max								
	STORAGE TEMP.,HUMID.AND ALTITUDE	-20 to +75°C, 20 - 90%RH (Non condensing) 9,000m (30,000feet) max								
	VIBRATION	10 - 55Hz, 19.6m/s ² (2G), 3minutes period, 60minutes each along X, Y and Z axis								
SAFETY AND NOISE REGULATIONS	IMPACT	196.1m/s ² (20G), 11ms, once each X, Y and Z axis								
	AGENCY APPROVALS (At only AC input)	UL60950-1, C-UL(CSA60950-1), EN62368-1 Complies with DEN-AN								
	CONDUCTED NOISE	Complies with FCC Part15 classB, VCCI-B, CISPR22-B, EN55011-B, EN55022-B								
	HARMONIC ATTENUATOR	Complies with IEC61000-3-2 *7								
OTHERS	CASE SIZE/WEIGHT	150×61×240mm [5.91×2.4×9.45 inches] (without terminal block and screw) (W×H×D) /2.2kg max								
	COOLING METHOD	Forced cooling (internal fan)								

*1 Measured by 20MHz oscilloscope or Ripple-Noise meter(equivalent to KEISOKU-GIKEN :RM101).
Ripple and ripple noise is measured on measuring board with capacitor of 22 μF within 150mm from the output terminal.
*2 Drift is the change in DC output for an eight hour period after a half-hour warm-up at 25°C.
*3 () means peak current. Peak loading for 10s. And Duty 35% max, refer to Instruction manual in detail.

*4 Overvoltage protection circuit to follow to output voltage setting. Standard overvoltage protection circuit is please contact us for details.
*5 Derating is required. Consult us for details.
*6 Please contact us about safety approvals for the model with option.
*7 Please contact us about class C.
* A sound may occur from power supply at pulse loading.

Block diagram

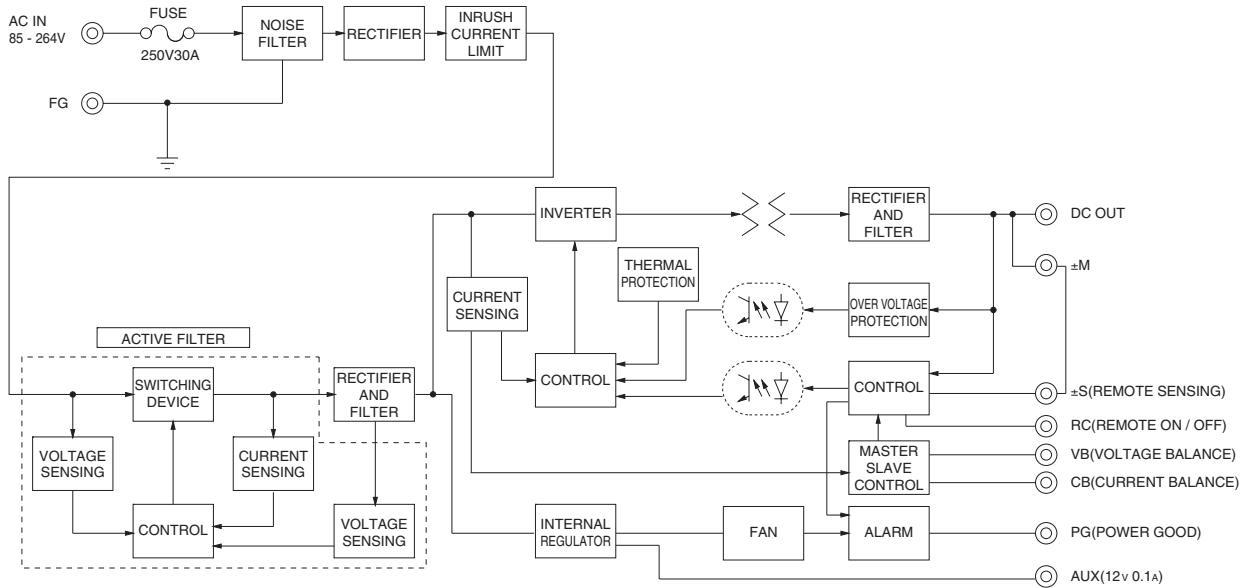

External view

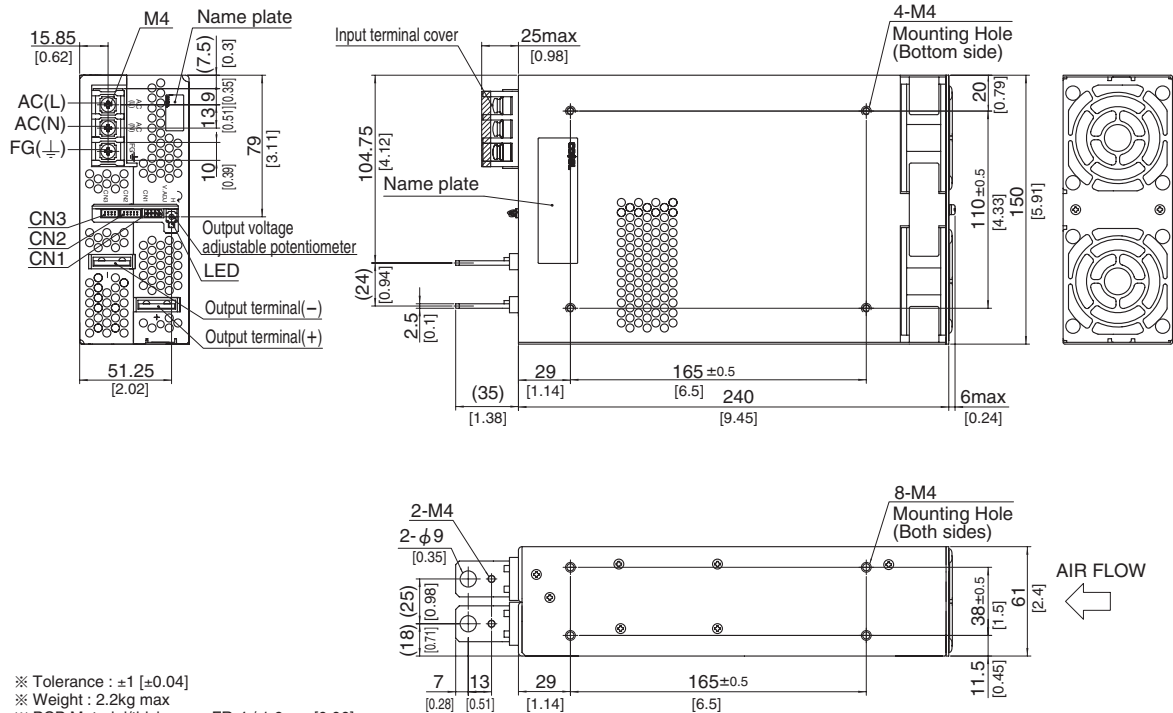

- ※ Tolerance : ±1 [±0.04]
- ※ Weight : 2.2kg max
- ※ PCB Material/thickness : FR-4 / 1.6mm [0.06]
- ※ Chassis material : Aluminum
- ※ Dimensions in mm, [] = inches
- ※ Mounting torque : 1.2N · m (12.8kgf · cm) max
- ※ Screw tightening torque : 1.6N · m (16.9kgf · cm) max
- ※ The housing for the remote sensing unused is mounted on CN1
- ※ Please connect safety ground to FG terminal on the unit.

PBA1500F

PB A 1500 F -5 -□

① ② ③ ④ ⑤ ⑥

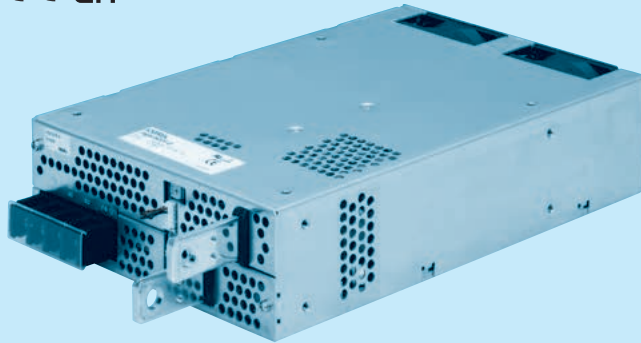
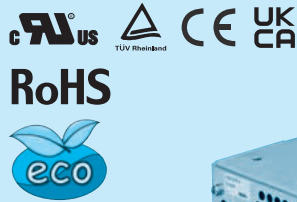

Example recommended EMI/EMC filter
NAC-20-472



High voltage pulse noise type : NAP series
Low leakage current type : NAM series
* A higher current rating EMI/EMC filter may be recommended in view of the other devices that could be connected in parallel with the power supply.

- ① Series name
- ② Single output
- ③ Output wattage
- ④ Universal input
- ⑤ Output voltage
- ⑥ Optional *6
- C : with Coating
- G : Low leakage current
- U : Operation stop voltage is set at a lower value
- F1 : With Long-Life fan
- F3 : Reverse air exhaust type
- F4 : Low speed fan

Refer to instruction manual 7.1.

*Make sure necessary tests will be carried out on your end equipment with the power supply installed in accordance with any required EMC/EMI regulations.

MODEL	PBA1500F-3R3	PBA1500F-5	PBA1500F-7R5	PBA1500F-12	PBA1500F-15	PBA1500F-24	PBA1500F-36	PBA1500F-48	
MAX OUTPUT WATTAGE[W]	990	1500	1500	1500	1500	1680	1692	1680	
DC OUTPUT	ACIN 100V	3.3V 300A	5V 300A	7.5V 200A	12V 125A	15V 100A	24V 65A	36V 42A	48V 32A
	ACIN 200V *3	3.3V 300A	5V 300A	7.5V 200A	12V 125A	15V 100A	24V 70(105)A	36V 47(70)A	48V 35A

SPECIFICATIONS

	MODEL	PBA1500F-3R3	PBA1500F-5	PBA1500F-7R5	PBA1500F-12	PBA1500F-15	PBA1500F-24	PBA1500F-36	PBA1500F-48	
INPUT	VOLTAGE[V]	AC85 - 264 1φ or DC120 - 370 (AC50 or DC70 Please refer to the instruction manual 7. option *5)								
	CURRENT[A]	ACIN 100V	15typ	19typ						
		ACIN 200V	8typ	10typ						
	FREQUENCY[Hz]	50/60 (47 - 63)								
	EFFICIENCY[%]	ACIN 100V	72typ	77typ	81typ	81typ	83typ	84typ	84typ	84typ
		ACIN 200V	75typ	81typ	83typ	84typ	86typ	87typ	87typ	87typ
	POWER FACTOR	ACIN 100V	0.98typ (Io=100%)							
ACIN 200V		0.95typ (Io=100%)								
INRUSH CURRENT[A]	ACIN 100V	20/40typ (Io=100%) (Primary inrush current /Secondary inrush current) (More than 10 sec. to re-start)								
	ACIN 200V	40/40typ (Io=100%) (Primary inrush current /Secondary inrush current) (More than 10 sec. to re-start)								
LEAKAGE CURRENT[mA]	0.9/1.5max (ACIN 100V/240V 60Hz, Io=100%, According to IEC62368-1, DENAN)									
OUTPUT	VOLTAGE[V]	3.3	5	7.5	12	15	24	36	48	
	CURRENT[A]	ACIN 100V	300	300	200	125	100	65	42	32
		ACIN 200V *3	300	300	200	125	100	70(105)	47(70)	35
	LINE REGULATION[mV]	20max	20max	36max	48max	60max	96max	144max	192max	
	LOAD REGULATION[mV]	40max	40max	60max	100max	120max	150max	150max	300max	
	RIPPLE[mVp-p]	0 to +50°C *1	80max	80max	120max	120max	120max	120max	150max	150max
		-20 - 0°C *1	140max	140max	160max	160max	160max	160max	160max	400max
	RIPPLE NOISE[mVp-p]	0 to +50°C *1	120max	120max	150max	150max	150max	150max	200max	200max
		-20 - 0°C *1	160max	160max	180max	180max	180max	180max	240max	500max
	TEMPERATURE REGULATION[mV]	0 to +50°C	40max	50max	75max	120max	150max	240max	360max	480max
		-20 to +50°C	60max	75max	120max	180max	180max	290max	440max	600max
	DRIFT[mV]	*2	12max	20max	30max	48max	60max	96max	144max	192max
START-UP TIME[ms]	600typ(ACIN 100/200V, Io=100%)									
HOLD-UP TIME[ms]	20typ (ACIN 100/200V, Io=100%)									
OUTPUT VOLTAGE ADJUSTMENT RANGE[V]	2.64 - 3.96	3.96 - 6.00	5.25 - 8.25	8.25 - 13.20	10.50 - 16.50	16.50 - 26.40	25.20 - 39.60	38.40 - 56.00		
OUTPUT VOLTAGE SETTING[V]	3.30 - 3.40	5.00 - 5.15	7.50 - 7.80	12.00 - 12.48	15.00 - 15.60	24.00 - 24.96	36.00 - 37.44	48.00 - 49.92		
PROTECTION CIRCUIT AND OTHERS	OVERCURRENT PROTECTION	Works over 105% of rated current or 101% of peak current and recovers automatically								
	OVERVOLTAGE PROTECTION[V] *4	Vo+0.66 - 1.32	Vo+1.0 - 2.0	Vo+1.5 - 3.0	Vo+2.4 - 4.8	Vo+3.0 - 6.0	Vo+4.8 - 9.6	Vo+7.2 - 14.4	Vo+4.8 - 12.0	
	OPERATING INDICATION	LED (Green)								
	REMOTE SENSING	Provided								
ISOLATION	REMOTE ON/OFF	Provided								
	INPUT-OUTPUT · RC	AC3.000V 1minute, Cutoff current = 25mA, DC500V 50MΩmin (At Room Temperature)								
	INPUT-FG	AC2.000V 1minute, Cutoff current = 25mA, DC500V 50MΩmin (At Room Temperature)								
	OUTPUT · RC · AUX-FG	AC500V 1minute, Cutoff current = 100mA, DC500V 50MΩmin (At Room Temperature)								
ENVIRONMENT	OUTPUT-RC · AUX	AC500V 1minute, Cutoff current = 100mA, DC500V 50MΩmin (At Room Temperature)								
	OPERATING TEMP., HUMID. AND ALTITUDE	-20 to +71°C (Refer to "Derating"), 20 - 90%RH (Non condensing) 3,000m (10,000feet) max								
	STORAGE TEMP., HUMID. AND ALTITUDE	-20 to +75°C, 20 - 90%RH (Non condensing) 9,000m (30,000feet) max								
	VIBRATION	10 - 55Hz, 19.6m/s ² (2G), 3minutes period, 60minutes each along X, Y and Z axis								
SAFETY AND NOISE REGULATIONS	IMPACT	196.1m/s ² (20G), 11ms, once each X, Y and Z axis								
	AGENCY APPROVALS (At only AC input)	UL60950-1, C-UL(CSA60950-1), EN62368-1 Complies with DEN-AN								
	CONDUCTED NOISE	Complies with FCC Part15 classB, VCCI-B, CISPR22-B, EN55011-B, EN55022-B, additional EMI/EMC Filter required for meeting class B								
	HARMONIC ATTENUATOR	Complies with IEC61000-3-2 *7								
OTHERS	CASE SIZE/WEIGHT	178×61×268mm [7.01×2.4×10.55 inches] (without terminal block and screw) (W×H×D) /3.4kg max								
	COOLING METHOD	Forced cooling (internal fan)								

*1 Measured by 20MHz oscilloscope or Ripple-Noise meter(equivalent to KEISOKU-GIKEN :RM101).
Ripple and ripple noise is measured on measuring board with capacitor of 22 μF within 150mm from the output terminal.
*2 Drift is the change in DC output for an eight hour period after a half-hour warm-up at 25°C.
*3 () means peak current. Peak loading for 10s. And Duty 35% max, refer to Instruction manual in detail.

*4 Overvoltage protection circuit to follow to output voltage setting. Standard overvoltage protection circuit is please contact us for details.
*5 Derating is required. Consult us for details.
*6 Please contact us about safety approvals for the model with option.
*7 Please contact us about class C.
* A sound may occur from power supply at pulse loading.

Block diagram

PBA/PBW

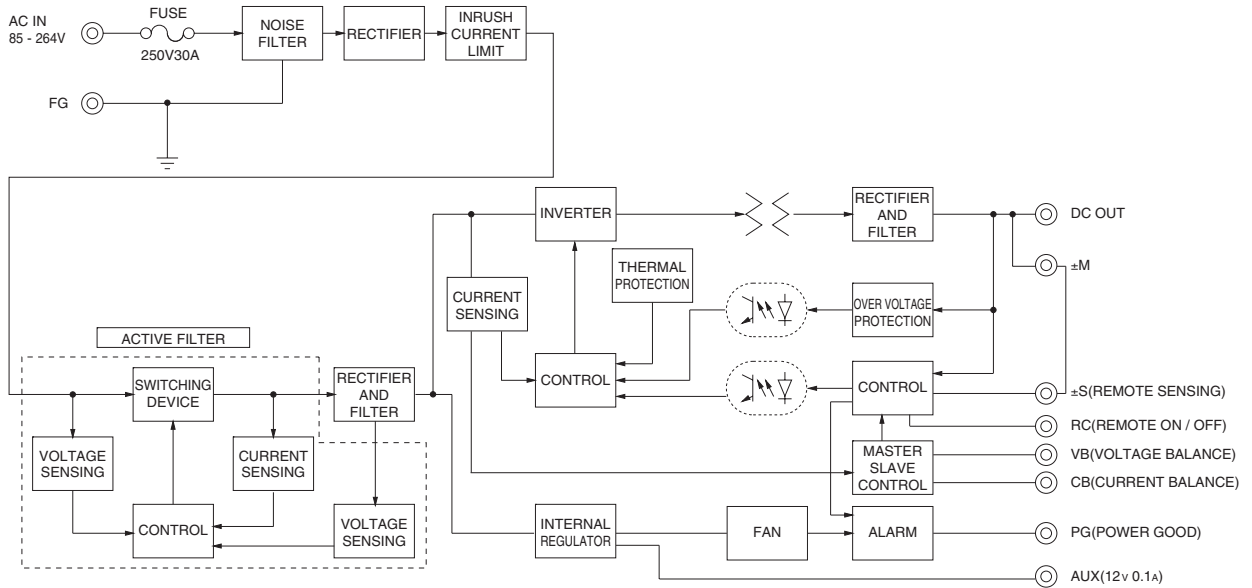

External view

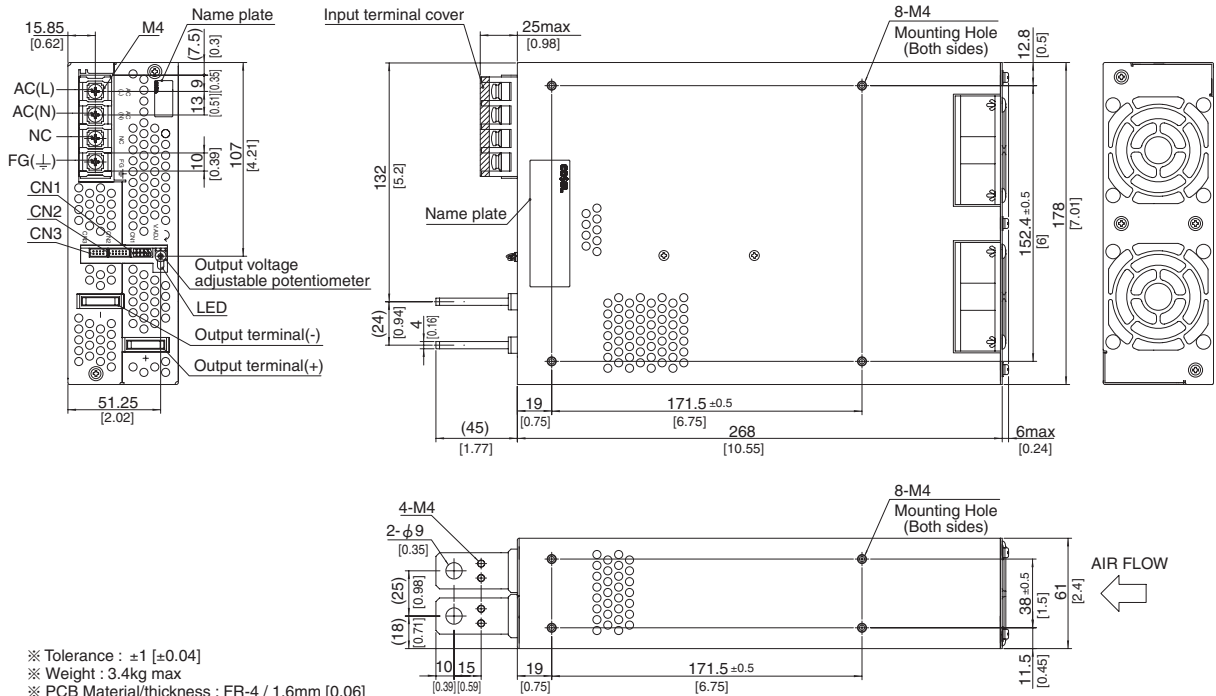

- ※ Tolerance : ± 1 [± 0.04]
- ※ Weight : 3.4kg max
- ※ PCB Material/thickness : FR-4 / 1.6mm [0.06]
- ※ Chassis material : Aluminum
- ※ Dimensions in mm, [] = inches
- ※ Mounting torque : $1.2\text{N} \cdot \text{m}$ (12.8kgf \cdot cm)max
- ※ Screw tightening torque : $1.6\text{N} \cdot \text{m}$ (16.9kgf \cdot cm)max
- ※ The housing for the remote sensing unused is mounted on CN1
- ※ Please connect safety ground to FG terminal on the unit.

PBA1500T

PB A 1500 T -5 -□

① ② ③ ④ ⑤ ⑥

PBA/PBW

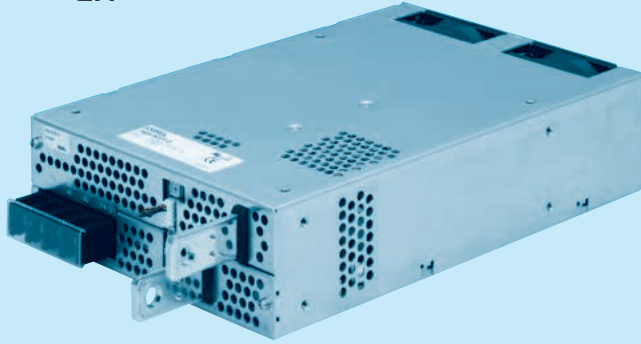
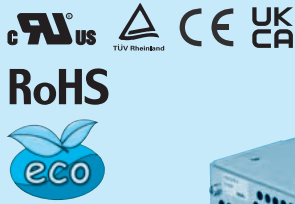

Example recommended EMI/EMC filter
TAC-10-683

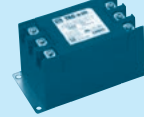

* A higher current rating EMI/EMC filter may be recommended in view of the other devices that could be connected in parallel with the power supply.

- ① Series name
- ② Single output
- ③ Output wattage
- ④ Triple input phase
- ⑤ Output voltage
- ⑥ Optional *6
- C :with Coating
- G :Low leakage current
- U :Operation stop voltage is set at a lower value
- F1 :With Long-Life fan
- F3 :Reverse air exhaust type
- F4 :Low speed fan

Refer to instruction manual 7.1.

*Make sure necessary tests will be carried out on your end equipment with the power supply installed in accordance with any required EMC/EMI regulations.

MODEL	PBA1500T-5	PBA1500T-12	PBA1500T-24	PBA1500T-48
MAX OUTPUT WATTAGE[W]	1500	1500	1680	1680
DC OUTPUT	ACIN 200V *3 5V 300A	12V 125A	24V 70(105)A	48V 35A

SPECIFICATIONS

	MODEL	PBA1500T-5	PBA1500T-12	PBA1500T-24	PBA1500T-48	
INPUT	VOLTAGE[V]	AC170 - 264 3φ (AC100 Please refer to the instruction manual 7. option *5)				
	CURRENT[A]	ACIN 200V 6typ				
	FREQUENCY[Hz]	50/60 (47 - 63)				
	EFFICIENCY[%]	ACIN 200V 81typ	84typ	87typ	87typ	
	POWER FACTOR	ACIN 200V 0.95typ (Io=100%)				
	INRUSH CURRENT[A]	ACIN 200V 40/40typ (Io=100%) (Primary inrush current /Secondary inrush current) (More than 10 sec. to re-start)				
	LEAKAGE CURRENT[mA]	1.5max (ACIN 240V 60Hz, Io=100%, According to IEC62368-1, DENAN)				
OUTPUT	VOLTAGE[V]	5	12	24	48	
	CURRENT[A]	ACIN 200V *3 300	125	70(105)	35	
	LINE REGULATION[mV]	20max	48max	96max	192max	
	LOAD REGULATION[mV]	40max	100max	150max	300max	
	RIPPLE[mVp-p]	0 to +50°C *1	80max	120max	120max	150max
		-20 - 0°C *1	140max	160max	160max	400max
	RIPPLE NOISE[mVp-p]	0 to +50°C *1	120max	150max	150max	200max
		-20 - 0°C *1	160max	180max	180max	500max
	TEMPERATURE REGULATION[mV]	0 to +50°C	50max	120max	240max	480max
		-20 to +50°C	75max	180max	290max	600max
	DRIFT[mV]	*2 20max	48max	96max	192max	
START-UP TIME[ms]	300typ(ACIN 200V, Io=100%) * Start-up time is 500ms typ for less than 1 minute of applying input again from turning off the input voltage.					
HOLD-UP TIME[ms]	20typ (ACIN 200V, Io=100%)					
OUTPUT VOLTAGE ADJUSTMENT RANGE[V]	3.96 - 6.00	8.25 - 13.20	16.50 - 26.40	38.40 - 56.00		
OUTPUT VOLTAGE SETTING[V]	5.00 - 5.15	12.00 - 12.48	24.00 - 24.96	48.00 - 49.92		
PROTECTION CIRCUIT AND OTHERS	OVERCURRENT PROTECTION	Works over 105% of rated current or 101% of peak current and recovers automatically				
	OVERVOLTAGE PROTECTION[V] *4	Vo+1.0 - 2.0	Vo+2.4 - 4.8	Vo+4.8 - 9.6	Vo+2.0 - 12.0	
	OPERATING INDICATION	LED (Green)				
	REMOTE SENSING	Provided				
ISOLATION	REMOTE ON/OFF	Provided				
	INPUT-OUTPUT · RC	AC3,000V 1minute, Cutoff current = 25mA, DC500V 50MΩmin (At Room Temperature)				
	INPUT-FG	AC2,000V 1minute, Cutoff current = 25mA, DC500V 50MΩmin (At Room Temperature)				
	OUTPUT · RC · AUX-FG	AC500V 1minute, Cutoff current = 100mA, DC500V 50MΩmin (At Room Temperature)				
ENVIRONMENT	OUTPUT-RC · AUX	AC500V 1minute, Cutoff current = 100mA, DC500V 50MΩmin (At Room Temperature)				
	OPERATING TEMP.,HUMID.AND ALTITUDE	-20 to +71°C (Refer to "Derating"), 20 - 90%RH (Non condensing) 3,000m (10,000feet) max				
	STORAGE TEMP.,HUMID.AND ALTITUDE	-20 to +75°C, 20 - 90%RH (Non condensing) 9,000m (30,000feet) max				
	VIBRATION	10 - 55Hz, 19.6m/s ² (2G), 3minutes period, 60minutes each along X, Y and Z axis				
SAFETY AND NOISE REGULATIONS	IMPACT	196.1m/s ² (20G), 11ms, once each X, Y and Z axis				
	AGENCY APPROVALS (At only AC input)	UL60950-1, C-UL(CSA60950-1), EN62368-1 Complies with DEN-AN				
	CONDUCTED NOISE	Complies with FCC Part15 classB, VCCI-B, CISPR22-B, EN55011-B, EN55022-B, additional EMI/EMC Filter required for meeting class B				
OTHERS	CASE SIZE/WEIGHT	178×61×268mm [7.01×2.4×10.55 inches] (without terminal block and screw) (W×H×D) /3.4kg max				
	COOLING METHOD	Forced cooling (internal fan)				

*1 Measured by 20MHz oscilloscope or Ripple-Noise meter(equivalent to KEISOKU-GIKEN :RM101).
Ripple and ripple noise is measured on measuring board with capacitor of 22 μF within 150mm from the output terminal.
*2 Drift is the change in DC output for an eight hour period after a half-hour warm-up at 25°C.
*3 () means peak current. Peak loading for 10s. And Duty 35% max, refer to Instruction manual in detail.

*4 Overvoltage protection circuit to follow to output voltage setting. Standard overvoltage protection circuit is please contact us for details.
*5 Derating is required. Consult us for details.
*6 Please contact us about safety approvals for the model with option.
* A sound may occur from power supply at pulse loading.

Block diagram

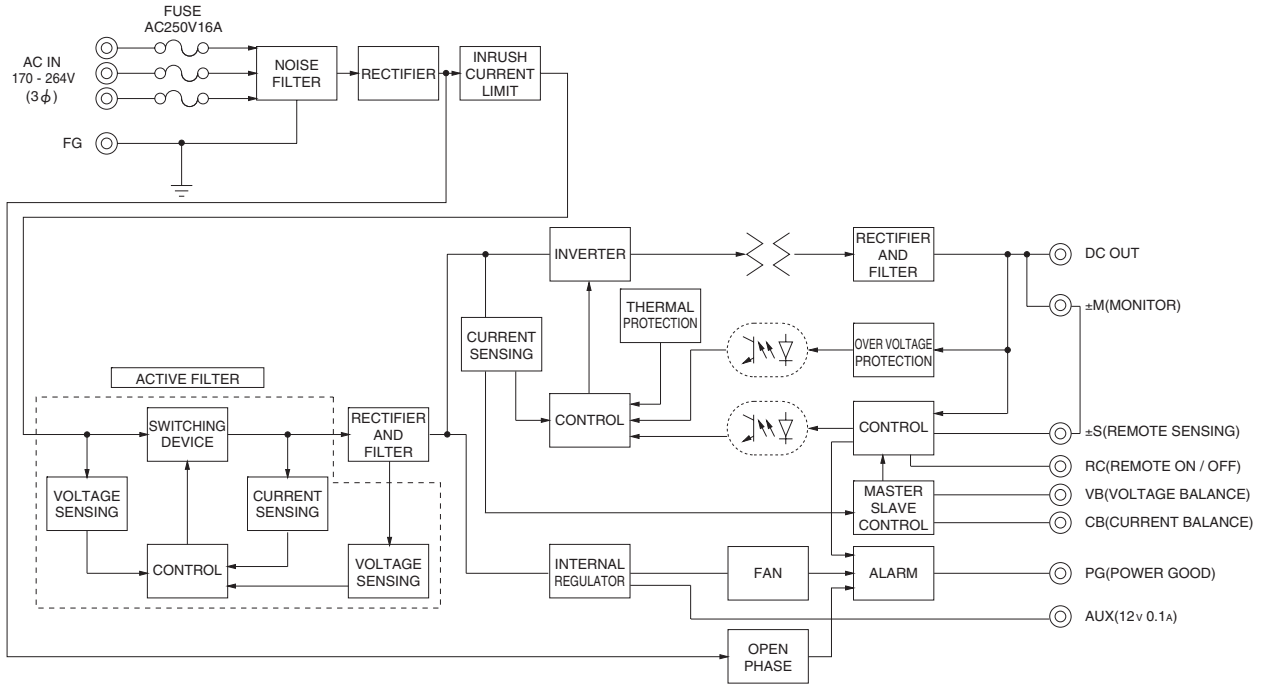

External view

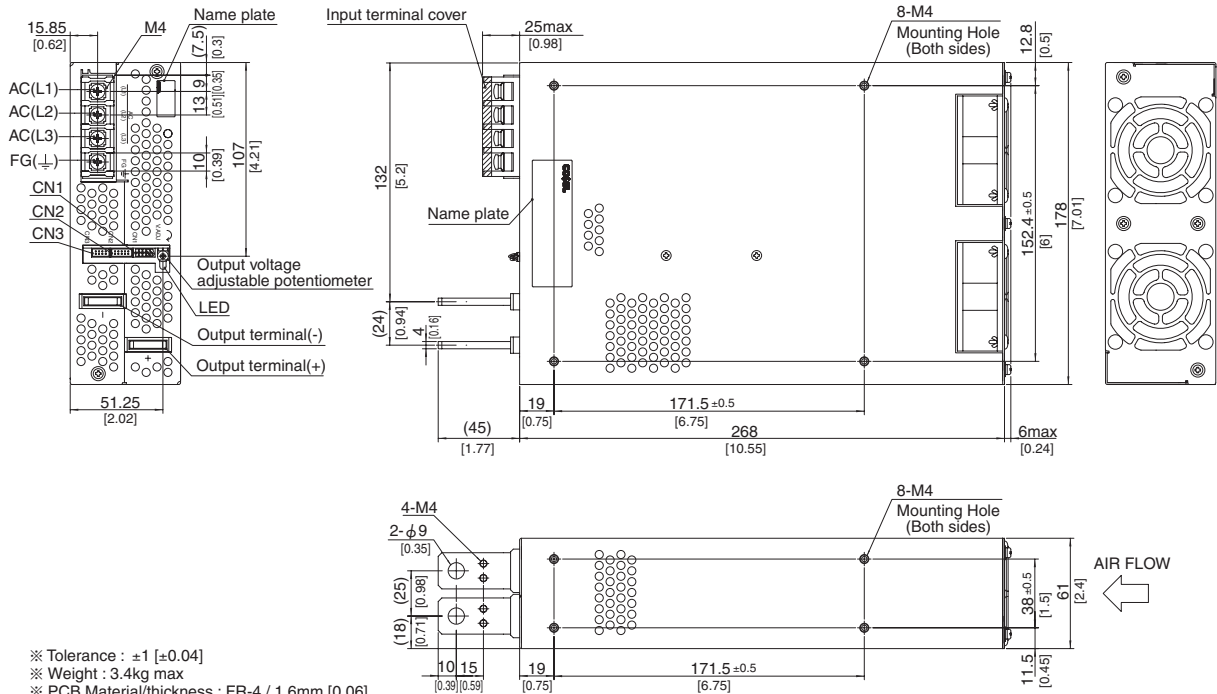

- ※ Tolerance : ± 1 [± 0.04]
- ※ Weight : 3.4kg max
- ※ PCB Material/thickness : FR-4 / 1.6mm [0.06]
- ※ Chassis material : Aluminum
- ※ Dimensions in mm, [] = inches
- ※ Mounting torque : $1.2N \cdot m$ (12.8kgf \cdot cm)max
- ※ Screw tightening torque : $1.6N \cdot m$ (16.9kgf \cdot cm)max
- ※ The housing for the remote sensing unused is mounted on CN1
- ※ Please connect safety ground to unit in M4 holes.

PBW15F

PB W 15 F - □ - □
 ① ② ③ ④ ⑤ ⑥

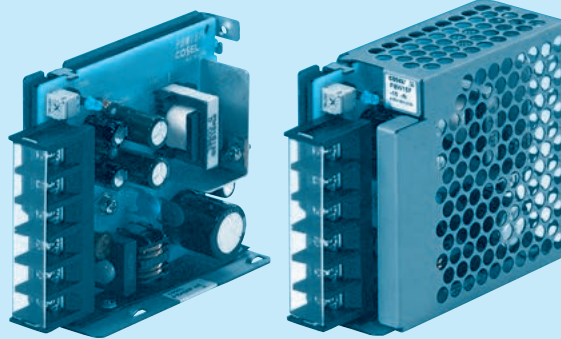
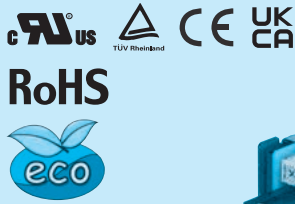

Example recommended EMI/EMC filter
NAC-06-472



High voltage pulse noise type : NAP series
 Low leakage current type : NAM series
 * A higher current rating EMI/EMC filter may be recommended in view of the other devices that could be connected in parallel with the power supply.

- ① Series name
- ② Dual output
- ③ Output wattage
- ④ Universal input
- ⑤ Output voltage
- ⑥ Optional *10
- C :with Coating
- G :Low leakage current

E :Low leakage current and EMI class A

T :Vertical terminal block
 J1 :VH (J.S.T) connector type
 N :with Cover
 Ni :with DIN rail
 V :Output voltage setting potentiometer externally

Cover is optional

*Make sure necessary tests will be carried out on your end equipment with the power supply installed in accordance with any required EMC/EMI regulations.

MODEL	PBW15F-12	PBW15F-15
MAX OUTPUT WATTAGE[W]	16.8	15.0
DC OUTPUT	VOLTAGE[V] *6	±12 (+24)
	CURRENT1[A]	0.7
	CURRENT2[A] *5	1.4

SPECIFICATIONS

	MODEL	PBW15F-12	PBW15F-15	
INPUT	VOLTAGE[V]	AC85 - 264 1 φ or DC110 - 370 (AC50 or DC70 Please refer to the instruction manual 1.1 Input voltage *8)		
	CURRENT[A]	ACIN 100V	0.40typ (CURRENT1)	
		ACIN 200V	0.20typ (CURRENT1)	
	FREQUENCY[Hz]	50/60 (47 - 440) or DC		
	EFFICIENCY[%]	ACIN 100V	74typ (CURRENT1)	78typ (CURRENT1)
		ACIN 200V	77typ (CURRENT1)	80typ (CURRENT1)
	INRUSH CURRENT[A]	ACIN 100V	15typ (CURRENT1) (At cold start)	
ACIN 200V		30typ (CURRENT1) (At cold start)		
LEAKAGE CURRENT[mA]	0.15/0.30max (ACIN 100V/240V 60Hz, Io=100%, According to IEC62368-1.DENAN)			
OUTPUT	VOLTAGE[V]	±12	±15 / (+30V reference number)	
	CURRENT1[A]	0.7	0.5 / 0.5	
	CURRENT2[A] *5	1.4	1.0 / -	
	LINE REGULATION[mV] *9	60max	60max / 96max	
	LOAD REGULATION 1[mV] *9	600max	600max / 150max	
	LOAD REGULATION 2[mV] *11	750max	750max / -	
	RIPPLE[mVp-p]	0 to +50°C *1	120max / 240max	120max / 240max
		-10 - 0°C *1	160max / 320max	160max / 320max
	RIPPLE NOISE[mVp-p]	0 to +50°C *1	150max / 300max	150max / 300max
		-10 - 0°C *1	180max / 360max	180max / 360max
	TEMPERATURE REGULATION[mV]	0 to +50°C	120max	150max
		-10 to +50°C	150max	180max
	DRIFT[mV] *2	48max		60max
	START-UP TIME[ms]	200typ(ACIN 100V, Io=100%) *Start-up time is 700ms typ for less than 1minute of applying input again from turning off the input voltage.		
HOLD-UP TIME[ms]	20typ (ACIN 100V, Io=100%)			
OUTPUT VOLTAGE ADJUSTMENT RANGE[V]	9.60 - 13.2 (+V and -V are simultaneously adjusted)		13.2 - 16.5 (+V and -V are simultaneously adjusted)	
OUTPUT VOLTAGE SETTING[V]	11.5 - 12.5 (+V and -V CURRENT1)		14.4 - 15.6 (+V and -V CURRENT1)	
PROTECTION CIRCUIT AND OTHERS	OVERCURRENT PROTECTION	Works over 105% of rated current and recovers automatically		
	OVERVOLTAGE PROTECTION[V]	16.8 - 24.0	20.0 - 29.0	
	OPERATING INDICATION	LED (Green)		
	REMOTE ON/OFF	None		
ISOLATION	INPUT-OUTPUT	AC3.000V 1minute, Cutoff current = 10mA, DC500V 50MΩ min (At Room Temperature)		
	INPUT-FG	AC2.000V 1minute, Cutoff current = 10mA, DC500V 50MΩ min (At Room Temperature)		
	OUTPUT-FG	AC500V 1minute, Cutoff current = 25mA, DC500V 50MΩ min (At Room Temperature)		
ENVIRONMENT	OPERATING TEMP.,HUMID.AND ALTITUDE	-10 to +71°C (Refer to "Derating"), 20 - 90%RH (Non condensing) 3,000m (10,000feet) max		
	STORAGE TEMP.,HUMID.AND ALTITUDE	-20 to +75°C, 20 - 90%RH (Non condensing) 9,000m (30,000feet) max		
	VIBRATION	10 - 55Hz, 19.6m/s ² (2G), 3minutes period, 60minutes each along X, Y and Z axis		
	IMPACT	196.1m/s ² (20G), 11ms, once each X, Y and Z axis		
SAFETY AND NOISE REGULATIONS	AGENCY APPROVALS (At only AC input)	UL60950-1, C-UL(CSA60950-1), EN62368-1 Complies with DEN-AN		
	CONDUCTED NOISE	Complies with FCC Part15 classB, VCCI-B, CISPR22-B, EN55011-B, EN55022-B		
	HARMONIC ATTENUATOR	Complies with IEC61000-3-2 (Not built-in to active filter *7) *12		
OTHERS	CASE SIZE/WEIGHT	31 X 78 X 85mm [1.22 X 3.07 X 3.35 inches] (without terminal block) (W X H X D) / 200g max (with cover : 235g max)		
	COOLING METHOD	Convection		

*1 Measured by 20MHz oscilloscope or Ripple-Noise meter(equivalent to KEISOKU-GIKEN : RM101).
 *2 Drift is the change in DC output for an eight hour period after a half-hour warm-up at 25°C.
 *3 Figures for 0 to rated current 1.The current not measured side is fixed.
 *4 Figures for 0 to rated current 2.The current not measured

side is fixed.
 *5 The sum of +power -power must be less than output power.
 *6 ±12, ±15 can be used as +24 and +30.
 *7 When two or more units are used, they may not comply with the harmonic attenuator. Please contact us for details.
 *8 Derating is required.
 *9 Figures to rated current 1.

*10 Please contact us about safety approvals for the model with option.
 *11 Please contact us about dynamic load and input response.
 *12 Please contact us about class C.
 * Parallel operation with other model is not possible.
 * Derating is required when operated with cover.
 * A sound may occur from power supply at peak loading.

Block diagram

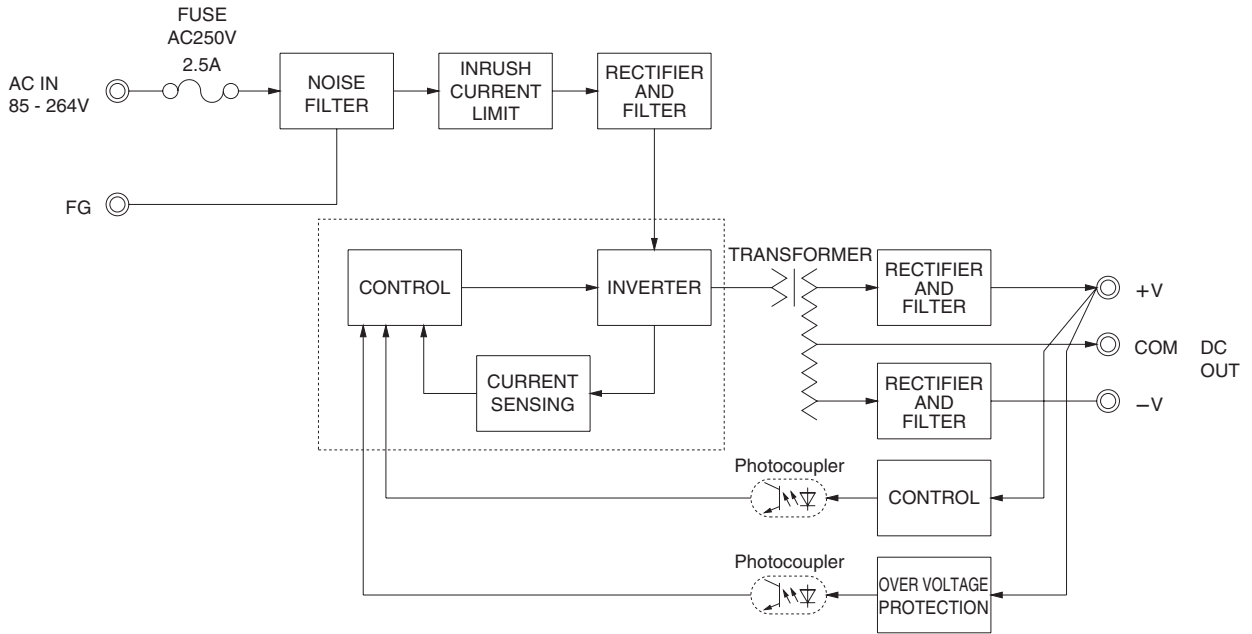

External view

※ External size of option T, J1, N1 and V is different from standard model and refer to 7 Option of instruction manual for details.

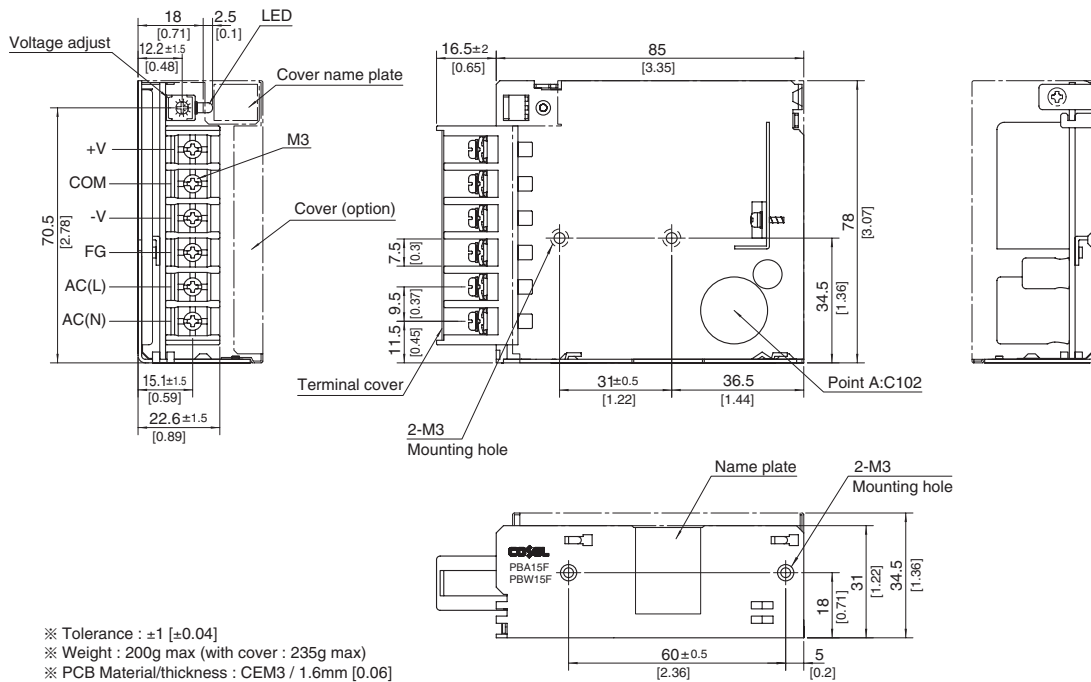

- ※ Tolerance : ±1 [±0.04]
- ※ Weight : 200g max (with cover : 235g max)
- ※ PCB Material/thickness : CEM3 / 1.6mm [0.06]
- ※ Chassis material : Hot-dip galvanized steel plate
- ※ Dimensions in mm, []= inches
- ※ Mounting torque : 0.6N • m(6.3kgf • cm)max
- ※ Screw tightening torque : M3 0.8N • m(8.5kgf • cm)max
- ※ Please connect safety ground to the unit in 2-M3 holes.

PBW30F

PB W 30 F - □ - □
 ① ② ③ ④ ⑤ ⑥

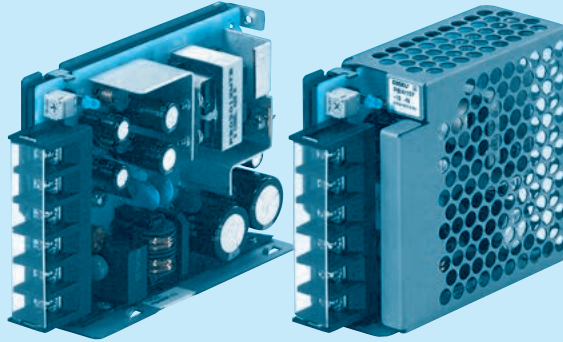
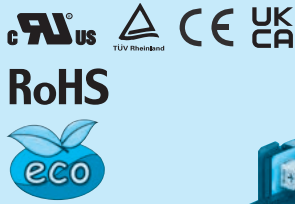

Example recommended EMI/EMC filter
NAC-06-472



High voltage pulse noise type : NAP series
 Low leakage current type : NAM series
 * A higher current rating EMI/EMC filter may be recommended in view of the other devices that could be connected in parallel with the power supply.

- ① Series name
- ② Dual output
- ③ Output wattage
- ④ Universal input
- ⑤ Output voltage
- ⑥ Optional *10
- C : with Coating
- G : Low leakage current

E : Low leakage current and EMI class A

T : Vertical terminal block
 J1 : V.H (J.S.T) connector type
 N : with Cover
 N1 : with DIN rail
 V : Output voltage setting potentiometer externally

Cover is optional

*Make sure necessary tests will be carried out on your end equipment with the power supply installed in accordance with any required EMC/EMI regulations.

MODEL	PBW30F-5	PBW30F-12	PBW30F-15
MAX OUTPUT WATTAGE[W]	15	31.2	30.0
DC OUTPUT	VOLTAGE[V] *6	±5 (+10)	±12 (+24)
	CURRENT1[A]	1.5	1.3
	CURRENT2[A] *5	2.0	1.7

SPECIFICATIONS

	MODEL	PBW30F-5	PBW30F-12	PBW30F-15	
INPUT	VOLTAGE[V]	AC85 - 264 1 φ or DC110 - 370 (AC50 or DC70 Please refer to the instruction manual 1.1 Input voltage *8)			
	CURRENT[A]	ACIN 100V	0.4typ (CURRENT1)	0.7typ (CURRENT1)	
		ACIN 200V	0.25typ (CURRENT1)	0.4typ (CURRENT1)	
	FREQUENCY[Hz]	50/60 (47 - 440) or DC			
	EFFICIENCY[%]	ACIN 100V	75typ (CURRENT1)	77typ (CURRENT1)	78typ (CURRENT1)
	ACIN 200V	75typ (CURRENT1)	81typ (CURRENT1)	79typ (CURRENT1)	
INRUSH CURRENT[A]	ACIN 100V	15typ (CURRENT1) (At cold start)			
	ACIN 200V	30typ (CURRENT1) (At cold start)			
LEAKAGE CURRENT[mA]	0.30/0.65max (ACIN 100V/240V 60Hz, Io=100%, According to IEC62368-1.DENAN)				
OUTPUT	VOLTAGE[V]	±5 / (+10V reference number)	±12 / (+24V reference number)	±15 / (+30V reference number)	
	CURRENT1[A]	1.5 / 1.5	1.3 / 1.3	1.0 / 1.0	
	CURRENT2[A] *5	2.0 / -	1.7 / -	1.4 / -	
	LINE REGULATION[mV] *3	20max / 36max	60max / 96max	60max / 96max	
	LOAD REGULATION 1[mV] *3	250max / 100max	600max / 150max	600max / 150max	
	LOAD REGULATION 2[mV] *11	500max / -	750max / -	750max / -	
	RIPPLE[mVp-p]	0 to +50°C *1	80max / 240max	120max / 240max	120max / 240max
		-10 - 0°C *1	140max / 320max	160max / 320max	160max / 320max
	RIPPLE NOISE[mVp-p]	0 to +50°C *1	120max / 300max	150max / 300max	150max / 300max
		-10 - 0°C *1	160max / 360max	180max / 360max	180max / 360max
	TEMPERATURE REGULATION[mV]	0 to +50°C	50max	120max	150max
	-10 to +50°C	60max	150max	180max	
	DRIFT[mV] *2	20max	48max	60max	
	START-UP TIME[ms]	200typ(ACIN 100V, Io=100%) * Start-up time is 70ms typ for less than 1minute of applying input again from turning off the input voltage.			
HOLD-UP TIME[ms]	20typ (ACIN 100V, Io=100%)				
OUTPUT VOLTAGE ADJUSTMENT RANGE[V]	4.99 - 6.00 (+V and -V are simultaneously adjusted)	9.60 - 13.2 (+V and -V are simultaneously adjusted)	13.2 - 16.5 (+V and -V are simultaneously adjusted)		
OUTPUT VOLTAGE SETTING[V]	4.99 - 5.30 (+V and -V CURRENT1)	11.5 - 12.5 (+V and -V CURRENT1)	14.4 - 15.6 (+V and -V CURRENT1)		
PROTECTION CIRCUIT AND OTHERS	OVERCURRENT PROTECTION	Works over 105% of rated current and recovers automatically			
	OVERVOLTAGE PROTECTION[V]	6.90 - 10.0	16.8 - 24.0	20.0 - 29.0	
	OPERATING INDICATION	LED (Green)			
	REMOTE ON/OFF	None			
ISOLATION	INPUT-OUTPUT	AC3,000V 1minute, Cutoff current = 10mA, DC500V 50MΩ min (At Room Temperature)			
	INPUT-FG	AC2,000V 1minute, Cutoff current = 10mA, DC500V 50MΩ min (At Room Temperature)			
	OUTPUT-FG	AC500V 1minute, Cutoff current = 25mA, DC500V 50MΩ min (At Room Temperature)			
ENVIRONMENT	OPERATING TEMP.,HUMID.AND ALTITUDE	-10 to +71°C (Refer to "Derating"), 20 - 90%RH (Non condensing) 3,000m (10,000feet) max			
	STORAGE TEMP.,HUMID.AND ALTITUDE	-20 to +75°C, 20 - 90%RH (Non condensing) 9,000m (30,000feet) max			
	VIBRATION	10 - 55Hz, 19.6m/s ² (2G), 3minutes period, 60minutes each along X, Y and Z axis			
	IMPACT	196.1m/s ² (20G), 11ms, once each X, Y and Z axis			
SAFETY AND NOISE REGULATIONS	AGENCY APPROVALS (At only AC input)	UL60950-1, C-UL(CSA60950-1), EN62368-1 Complies with DEN-AN			
	CONDUCTED NOISE	Complies with FCC Part15 classB, VCCI-B, CISPR22-B, EN55011-B, EN55022-B			
	HARMONIC ATTENUATOR	Complies with IEC61000-3-2 (Not built-in to active filter *7) *12			
OTHERS	CASE SIZE/WEIGHT	31 X 78 X 103mm [1.22 X 3.07 X 4.06 inches] (without terminal block) (W X H X D) / 270g max (with cover : 310g max)			
	COOLING METHOD	Convection			

*1 Measured by 20MHz oscilloscope or Ripple-Noise meter(equivalent to KEISOKU-GIKEN : RM101).
 *2 Drift is the change in DC output for an eight hour period after a half-hour warm-up at 25°C.
 *3 Figures for 0 to rated current 1.The current not measured side is fixed.
 *4 Figures for 0 to rated current 2.The current not measured

side is fixed.
 *5 The sum of +power -power must be less than output power.
 *6 ±5, ±12, ±15 can be used as +10, +24 and +30.
 *7 When two or more units are used, they may not comply with the harmonic attenuator. Please contact us for details.
 *8 Derating is required.
 *9 Figures to rated current 1.

*10 Please contact us about safety approvals for the model with option.
 *11 Please contact us about dynamic load and input response.
 *12 Please contact us about class C.
 * Parallel operation with other model is not possible.
 * Derating is required when operated with cover.
 * A sound may occur from power supply at peak loading.

Block diagram

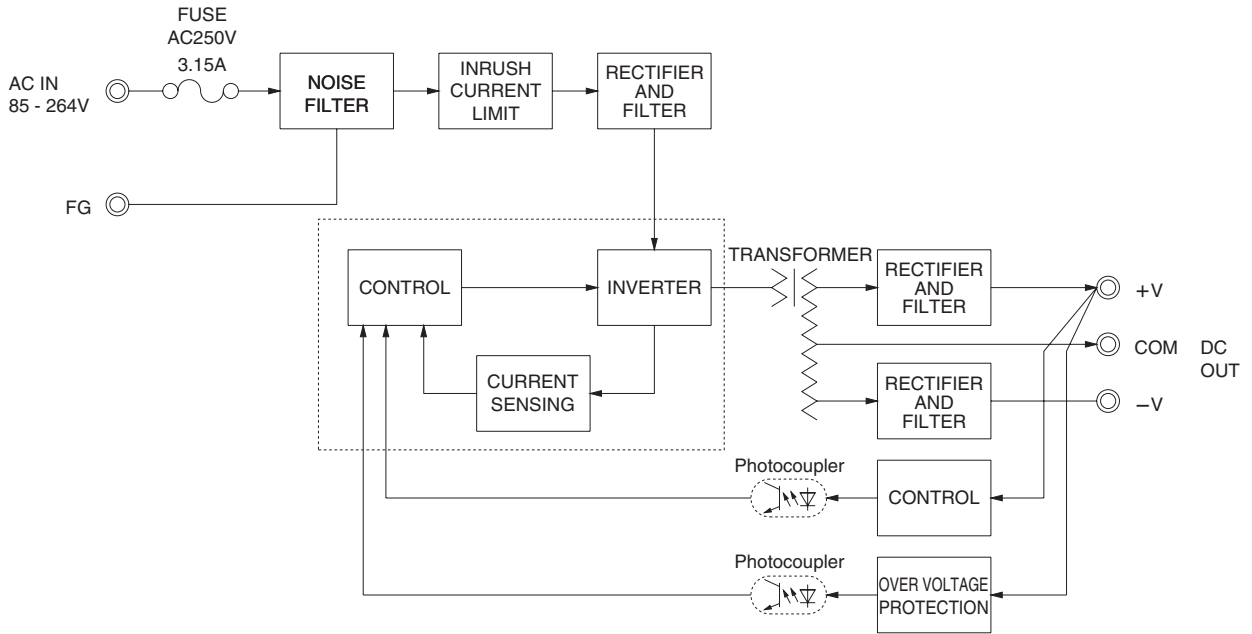

External view

※ External size of option T, J1, N1 and V is different from standard model and refer to 7 Option of instruction manual for details.

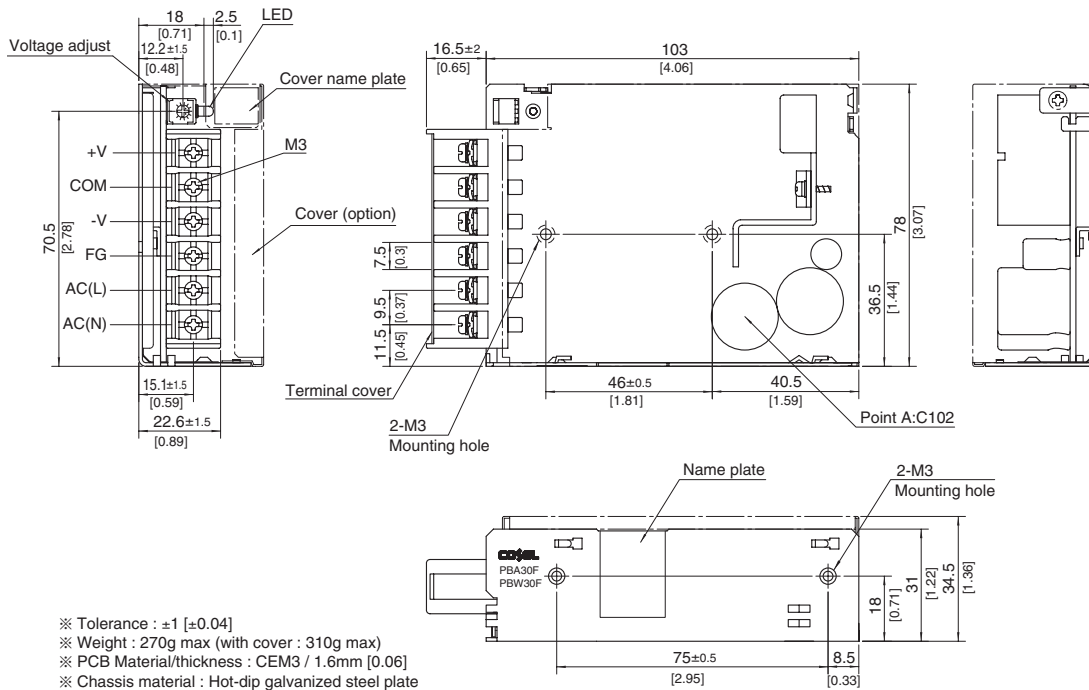

- ※ Tolerance : ± 1 [± 0.04]
- ※ Weight : 270g max (with cover : 310g max)
- ※ PCB Material/thickness : CEM3 / 1.6mm [0.06]
- ※ Chassis material : Hot-dip galvanized steel plate
- ※ Dimensions in mm, [] = inches
- ※ Mounting torque : $0.6\text{N} \cdot \text{m}$ ($6.3\text{kgf} \cdot \text{cm}$)max
- ※ Screw tightening torque : $\text{M3 } 0.8\text{N} \cdot \text{m}$ ($8.5\text{kgf} \cdot \text{cm}$)max
- ※ Please connect safety ground to the unit in 2-M3 holes.

PBW50F

PB W 50 F -□ -□
 ① ② ③ ④ ⑤ ⑥

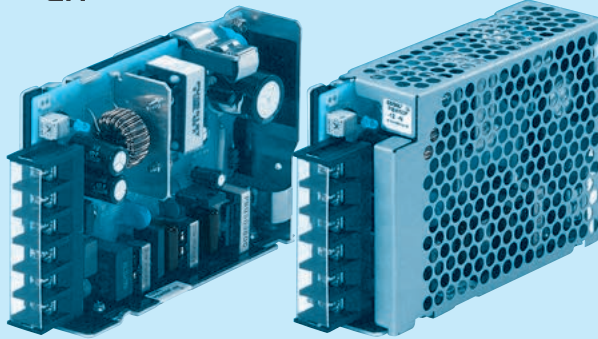
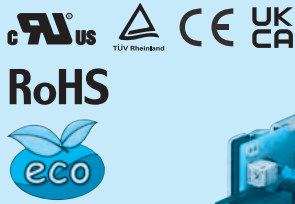

Example recommended EMI/EMC filter
NAC-06-472



High voltage pulse noise type : NAP series
 Low leakage current type : NAM series
 * A higher current rating EMI/EMC filter may be recommended in view of the other devices that could be connected in parallel with the power supply.

- ① Series name
- ② Dual output
- ③ Output wattage
- ④ Universal input
- ⑤ Output voltage
- ⑥ Optional *9
 C :with Coating
 G :Low leakage current (0.15mA max / ACIN 240V)
 E :Low leakage current and EMI class A (0.5mA max / ACIN 240V)
 T :Vertical terminal block
 J1 :VH (J.S.T.) connector type
 R :with Remote ON/OFF
 N :with Cover
 NI :with DIN rail
 V :Output voltage setting potentiometer externaly

Cover is optional

*Make sure necessary tests will be carried out on your end equipment with the power supply installed in accordance with any required EMC/EMI regulations.

MODEL	PBW50F-5	PBW50F-12	PBW50F-15
MAX OUTPUT WATTAGE[W]	30	50.4	51
DC OUTPUT	VOLTAGE[V] *8	±5 (+10)	±12 (+24)
	CURRENT1[A]	3.0	2.1
	CURRENT2[A] *6	4.0	2.7

SPECIFICATIONS

	MODEL	PBW50F-5	PBW50F-12	PBW50F-15	
INPUT	VOLTAGE[V]	AC85 - 264 1 φ or DC120 - 370 (AC50 or DC70 Please refer to the instruction manual 1.1 Input voltage *3)			
	CURRENT[A]	ACIN 100V	0.45typ (CURRENT1)	0.70typ (CURRENT1)	
		ACIN 200V	0.30typ (CURRENT1)	0.40typ (CURRENT1)	
	FREQUENCY[Hz]	50/60 (47 - 63)			
	EFFICIENCY[%]	ACIN 100V	76typ (CURRENT1)	81typ (CURRENT1)	
		ACIN 200V	77typ (CURRENT1)	83typ (CURRENT1)	
	POWER FACTOR(lo=100%)	ACIN 100V	0.98typ	0.99typ	
ACIN 200V		0.87typ	0.93typ		
INRUSH CURRENT[A]	ACIN 100V	15typ (CURRENT1) (At cold start)			
	ACIN 200V	30typ (CURRENT1) (At cold start)			
LEAKAGE CURRENT[mA]	0.40/0.75max (ACIN 100V/240V 60Hz, lo=100%, According to IEC62368-1.DENAN)				
OUTPUT	VOLTAGE[V]	±5 / (+10V reference number)	±12 / (+24V reference number)	±15 / (+30V reference number)	
	CURRENT1[A]	3.0 / 3.0	2.1 / 2.1	1.7 / 1.7	
	CURRENT2[A]	4.0 / -	2.7 / -	2.4 / -	
	LINE REGULATION[mV]	20max / 36max	48max / 96max	60max / 96max	
	LOAD REGULATION 1[mV]	250max / 100max	600max / 150max	600max / 150max	
	LOAD REGULATION 2[mV]	500max / -	750max / -	750max / -	
	RIPPLE[mVp-p]	0 to +50°C *1	80max / 240max	120max / 240max	120max / 240max
		-10 - 0°C *1	140max / 320max	160max / 320max	160max / 320max
	RIPPLE NOISE[mVp-p]	0 to +50°C *1	120max / 300max	150max / 300max	150max / 300max
		-10 - 0°C *1	160max / 360max	180max / 360max	180max / 360max
	TEMPERATURE REGULATION[mV]	0 to +50°C	50max	120max	150max
		-10 to +50°C	60max	150max	180max
	DRIFT[mV]	20max	48max	60max	
	START-UP TIME[ms]	350typ(ACIN 100V, lo=100%)			
HOLD-UP TIME[ms]	20typ (ACIN 100V, lo=100%)				
OUTPUT VOLTAGE ADJUSTMENT RANGE[V]	4.99 - 6.00 (+V and -V are simultaneously adjusted)	9.60 - 13.2 (+V and -V are simultaneously adjusted)	13.2 - 16.5 (+V and -V are simultaneously adjusted)		
OUTPUT VOLTAGE SETTING[V]	4.99 - 5.30 (+V and -V CURRENT1)	11.5 - 12.5 (+V and -V CURRENT1)	14.4 - 15.6 (+V and -V CURRENT1)		
PROTECTION CIRCUIT AND OTHERS	OVERCURRENT PROTECTION	Works over 105% of rated current and recovers automatically			
	OVERVOLTAGE PROTECTION[V]	6.90 - 10.0	16.8 - 24.0	20.0 - 29.0	
	OPERATING INDICATION	LED (Green)			
REMOTE ON/OFF	Optional (Required external power source)				
ISOLATION	INPUT-OUTPUT - RC	*7 AC3.000V 1minute, Cutoff current = 10mA, DC500V 50MΩ min (At Room Temperature)			
	INPUT-FG	AC2.000V 1minute, Cutoff current = 10mA, DC500V 50MΩ min (At Room Temperature)			
	OUTPUT - RC-FG	*7 AC500V 1minute, Cutoff current = 100mA, DC500V 50MΩ min (At Room Temperature)			
ENVIRONMENT	OPERATING TEMP.,HUMID.AND ALTITUDE	-10 to +71°C (Refer to "Derating"), 20 - 90%RH (Non condensing) 3,000m (10,000feet) max			
	STORAGE TEMP.,HUMID.AND ALTITUDE	-20 to +75°C, 20 - 90%RH (Non condensing) 9,000m (30,000feet) max			
	VIBRATION	10 - 55Hz, 19.6m/s ² (2G), 3minutes period, 60minutes each along X, Y and Z axis			
SAFETY AND NOISE REGULATIONS	IMPACT	196.1m/s ² (20G), 11ms, once each X, Y and Z axis			
	AGENCY APPROVALS (At only AC input)	UL60950-1, C-UL(CSA60950-1), EN62368-1 Complies with DEN-AN			
	CONDUCTED NOISE	Complies with FCC Part15 classB, VCCI-B, CISPR22-B, EN55011-B, EN55022-B			
	HARMONIC ATTENUATOR	Complies with IEC61000-3-2 *10			
OTHERS	CASE SIZE/WEIGHT	31 x 82 x 120mm [1.22 x 3.23 x 4.72 inches] (without terminal block) (W x H x D) / 280g max (with cover : 325g max)			
	COOLING METHOD	Convection			

*1 Measured by 20MHz oscilloscope or Ripple-Noise meter(equivalent to KEISOKU-GIKEN : RM101).
 *2 Drift is the change in DC output for an eight hour period after a half-hour warm-up at 25°C.
 *3 Derating is required.
 *4 Figures for 0 to rated current 1.The current not measured side is fixed.
 *5 Figures for 0 to rated current 2.The current not measured side is fixed.
 *6 The sum of +power -power must be less than output power.
 *7 RC is applied to remote ON/OFF option. RC is isolated with input/output and FG.
 *8 ±5, ±12, ±15 can be used as +10,+24 and +30.
 *9 Please contact us about safety approvals for the model with option.
 *10 Please contact us about class C.
 * Parallel operation with other model is not possible.
 * Derating is required when operated with cover.
 * A sound may occur from power supply at peak loading.

Block diagram

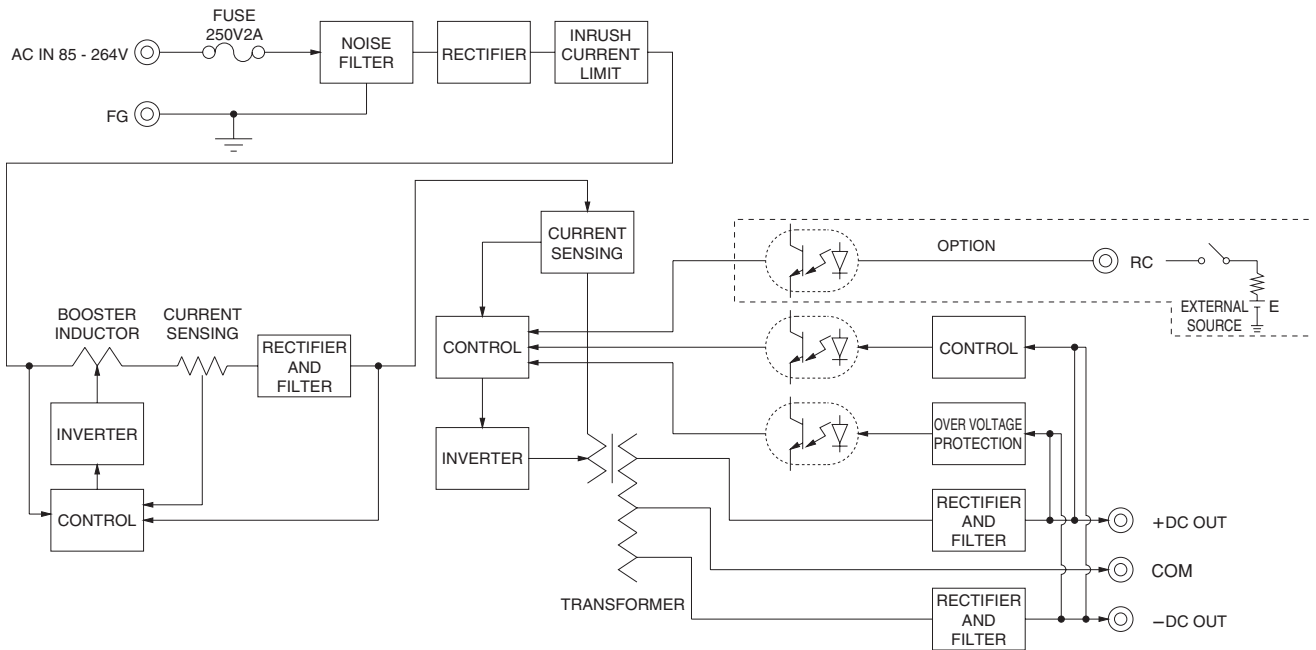

External view

※ External size of option T,J1,R,N1 and V is different from standard model and refer to 7 Option of instruction manual for details.

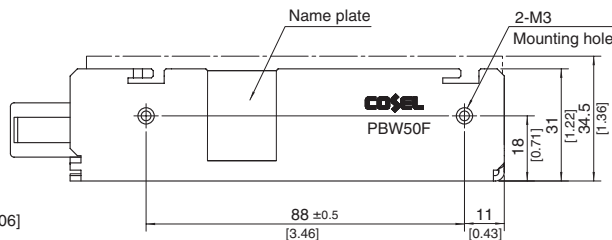
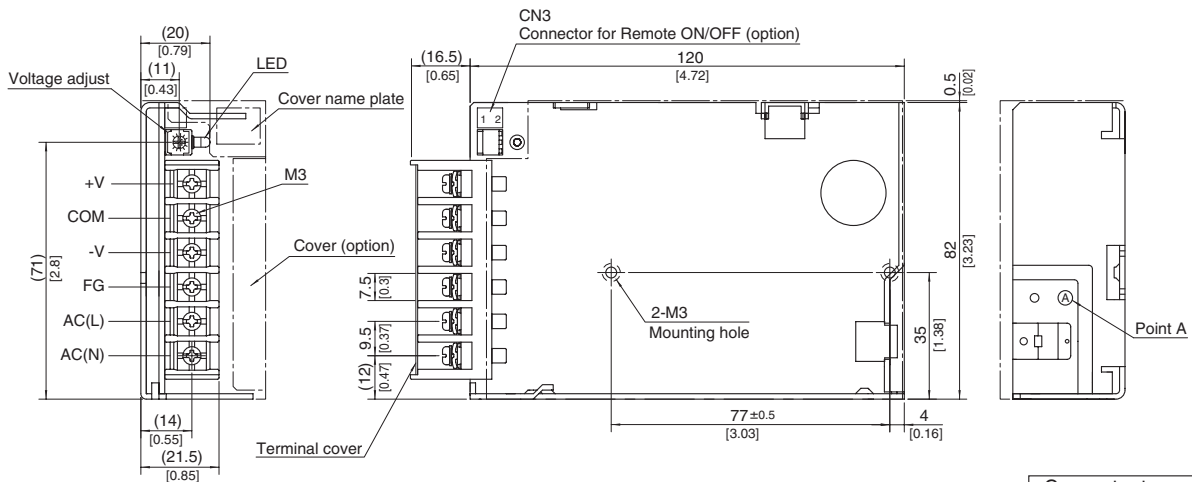

Connector type	
CN3 Option (Mfr : J.S.T.)	
Pin No.	Contents
1	RC(+)
2	RC(-)

Barrier strip type
 Model B2B-XH-A
 Mating Connector (Terminal)
 XHP-2
 (BXH-001T-P0.6
 or SXH-001T-P0.6)

- ※ Tolerance : ±1 [±0.04]
- ※ Weight : 280g max (with cover : 325g max)
- ※ PCB Material/thickness : CEM3 / 1.6mm [0.06]
- ※ Chassis material : Aluminum
- ※ Dimensions in mm, [] = inches
- ※ Mounting torque : 0.49N • m(5kgf • cm)max
- ※ Screw tightening torque : M3 0.8N • m(8.5kgf • cm)max
- ※ Please connect safety ground to the unit in 2-M3 holes.

Terminal Blocks

* The following information covers PBA300F - 1500F. Please see External View for PBA10F - 150F and PBW15F - 50F.

● PBA300F

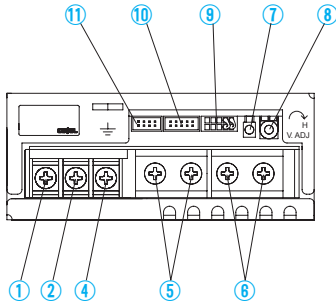

● PBA600F

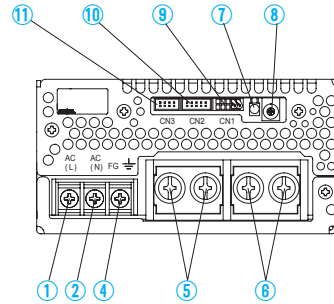

● PBA1000F

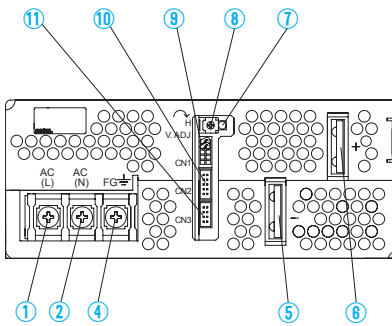

● PBA1500F

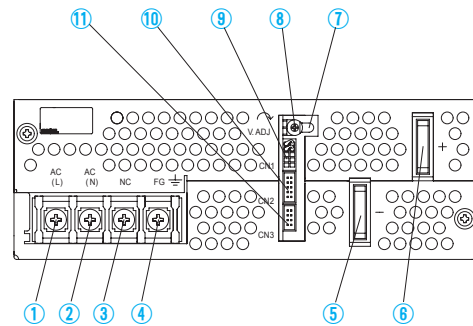

● PBA1500T

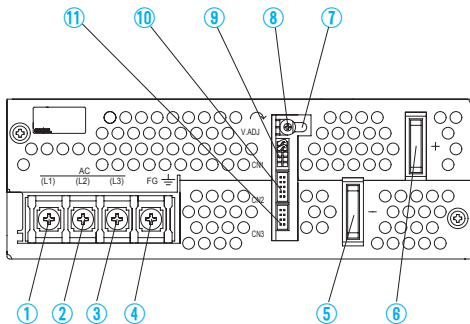

*PBA300F - 1500F

- ① AC (L) } Input Terminals AC85 - 264V ϕ 47 - 63Hz
- ② AC (N) } (M4)
- ③ NC
- ④ Frame ground (M4 \perp)
- ⑤ -Output
- ⑥ +Output
- ⑦ LED
- ⑧ Output voltage adjustable potentiometer
- ⑨ CN1 } Connectors
- ⑩ CN2 }
- ⑪ CN3 }

* Please see Optional Parts for dedicated harnesses.

*PBA1500T

- ① AC (L1)
- ② AC (L2)
- ③ AC (L3)
- ④ Frame ground (M4 \perp)
- ⑤ -Output
- ⑥ +Output
- ⑦ LED
- ⑧ Output voltage adjustable potentiometer
- ⑨ CN1 } Connectors
- ⑩ CN2 }
- ⑪ CN3 }

Terminal Blocks

● PBA300F, 600F Pin Configuration

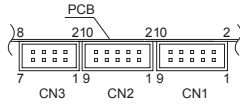

● PBA1000F, 1500F Pin Configuration

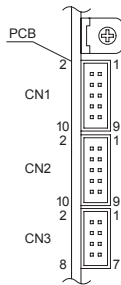

Pin Configuration and Functions of CN1 and CN2

Pin No.	Function
1	+M : Self sensing terminal. (Do not wire for external connection.)
2	+S : +Sensing
3	-M : Self sensing terminal. (Do not wire for external connection.)
4	-S : -Sensing
5	VB : Voltage balance
6	CB : Current balance
7	TRM : Adjustment of output voltage
8	-S : -Sensing
9	RC2 : Remote ON/OFF
10	RCG : Remote ON/OFF (GND)

Pin Configuration and Functions of CN3

Pin No.	Function
1	-S : -Sensing
2	-S : -Sensing
3	AUX : Auxiliary output (12V 0.1A)
4	RC1 : Remote ON/OFF
5	AUXG : Auxiliary output (GND)
6	N.C. : No connection
7	PG : Alarm
8	PGG : Alarm (GND)

*Common signs among CN1, CN2 and CN3 such as -S represent the same potential.

Matching connectors and terminals on CN1, CN2 and CN3

Connector	Housing	Terminal	Mfr.
CN1 CN2	S10B-PHDSS PHDR-10VS	Reel : SPHD-002T-P0.5 Loose : BPHD-001T-P0.5	J.S.T.
CN3	S8B-PHDSS PHDR-08VS		

Assembling and Installation Method

Installation Method

■ Do not insert a screw more than 6mm from the outside of a power supply to keep enough insulation distance between the screw and internal components.

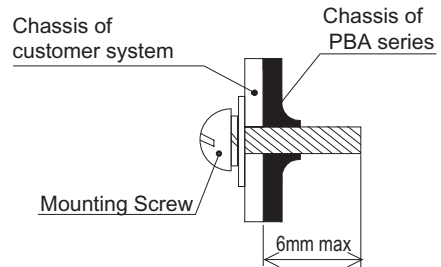

● PBA10F, PBA15F, PBW15F, PBA30F, PBW30F, PBA50F, PBW50F, PBA75F, PBA100F and PBA150F

- If you use two or more power supplies side by side, please keep a sufficient distance between them to allow enough air ventilation.
- Ambient temperature around each power supply should not exceed the temperature range shown in "derating".

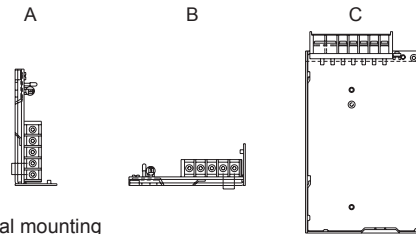

Normal mounting

● PBA300F, PBA600F, PBA1000F, PBA1500F and PBA1500T

- The power supplies have a built-in forced cooling fan. Do not block ventilation at the suction side (terminal block side) and its opposite side (fan installation side). If you need to secure a power supply by screws, securely fix it, taking into consideration of its weight. You can install it in any direction.
- If you use a power supply in a dusty environment, it can give a cause for a failure. Please consider taking such countermeasures as installing an air filter near the suction area of the system to prevent a failure.
- In PBA300F, PBA1500F and PBA1500T, ventilation holes are located on the mounting side. If you would like to install the unit by using that side, please contact us for details.

Derating

- PBA10F, PBA15F, PBW15F, PBA30F, PBW30F
- PBA1500F Input voltage Derating Curve

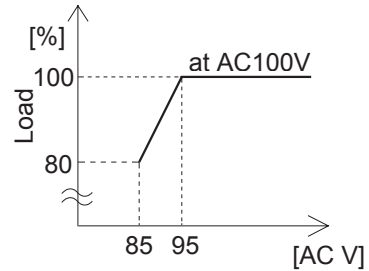
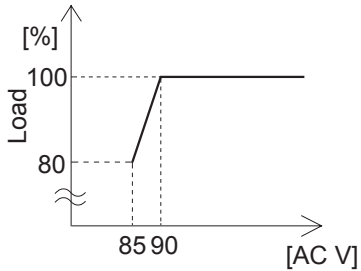

- PBA10F, PBA15F, PBW15F, PBA30F, PBW30F, PBA50F, PBW50F, PBA75F, PBA100F, PBA150F Ambient temperature derating curve

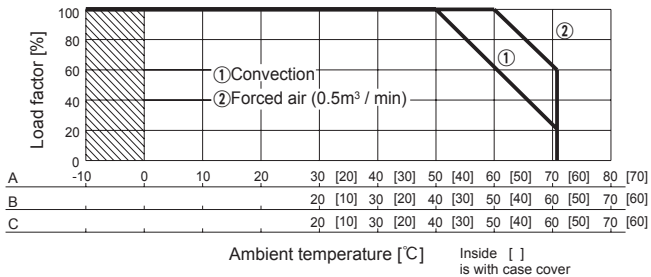

- In the hatched area, the specification of Ripple, Ripple Noise is different from other area.
- The ambient temperature should be measured 5 to 10 cm away from the power supply so that it won't be influenced by the heat from the power supply. Please consult us for more details.
- Make sure the temperature at point A is less than the temperatures shown in Instruction Manual 4.

- PBA300F, PBA600F, PBA1000F, PBA1500F, PBA1500T Ambient temperature derating curve

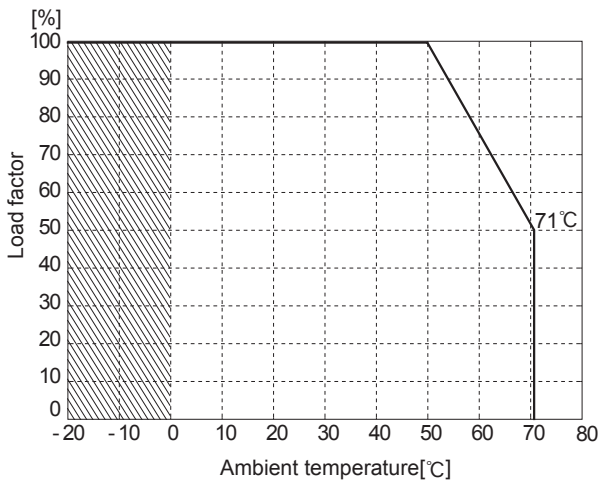

- In the hatched area, the specification of Ripple, Ripple Noise is different from other area.
- Derating curve depending on an ambient temperature (temperature of air sucked in for a cooling purpose) is shown above.

Instruction Manual

◆ It is necessary to read the “Instruction Manual” and “Before using our product” before you use our product.

Instruction Manual <https://www.cosel.co.jp/redirect/catalog/en/PBA/>
 Instruction Manual <https://www.cosel.co.jp/redirect/catalog/en/PBW/>
 Before using our product <https://en.cosel.co.jp/technical/caution/index.html>



Basic Characteristics Data

Model	Circuit method	Switching frequency [kHz]	Input current [A]	Rated input fuse	Inrush current protection circuit	PCB/Pattern			Series/Parallel operation availability	
						Material	Single sided	Double sided	Series operation	Parallel operation
PBA10F	Flyback converter	100	0.3	250V 2.5A	LF	CEM-3	Yes		Yes	*1
PBA15F	Flyback converter	100	0.4		Thermistor	CEM-3	Yes		Yes	*1
PBA30F	Flyback converter	100	0.7		Thermistor	CEM-3	Yes		Yes	*1
PBA50F	Active filter	60 - 550	0.7	250V 2A	Thermistor	CEM-3	Yes		Yes	*1
	Forward converter	130								
PBA75F	Active filter	60 - 550	1.0	250V 3.15A	Thermistor	CEM-3	Yes		Yes	*1
	Forward converter	120								
PBA100F	Active filter	60 - 550	1.3	250V 3.15A	Thermistor	CEM-3	Yes		Yes	*1
	Forward converter	120								
PBA150F	Active filter	60 - 550	2.0	250V 4A	Thermistor	CEM-3	Yes		Yes	*1
	Forward converter	120								
PBA300F	Active filter	230	4.1	250V 10A	SCR	FR-4		Yes	Yes	Yes
	Forward converter	330								
PBA600F	Active filter	130	8.2	250V 15A	SCR	FR-4		Yes	Yes	Yes
	Forward converter	330								
PBA1000F	Active filter	130	13	250V 30A	SCR	FR-4		Yes	Yes	Yes
	Forward converter	280								
PBA1500F	Active filter	130	19	250V 30A	SCR	FR-4		Yes	Yes	Yes
	Forward converter	200								
PBA1500T	Active filter	130	6	250V 16A	SCR	FR-4		Yes	Yes	Yes
	Forward converter	200								
PBW15F	Flyback converter	100	0.4	250V 2.5A	Thermistor	CEM-3	Yes		Yes	*1
PBW30F	Flyback converter	100	0.7	250V 3.15A	Thermistor	CEM-3	Yes		Yes	*1
PBW50F	Active filter	60 - 550	0.7	250V 2A	Thermistor	CEM-3	Yes		Yes	*1
	Forward converter	130								

*1 Refer to Series/Parallel Operation of Instruction Manual.

* The value of input current is at ACIN 100V and rated load, ACIN 200V 3 φ and rated load in PBA1500T.



PJA-series

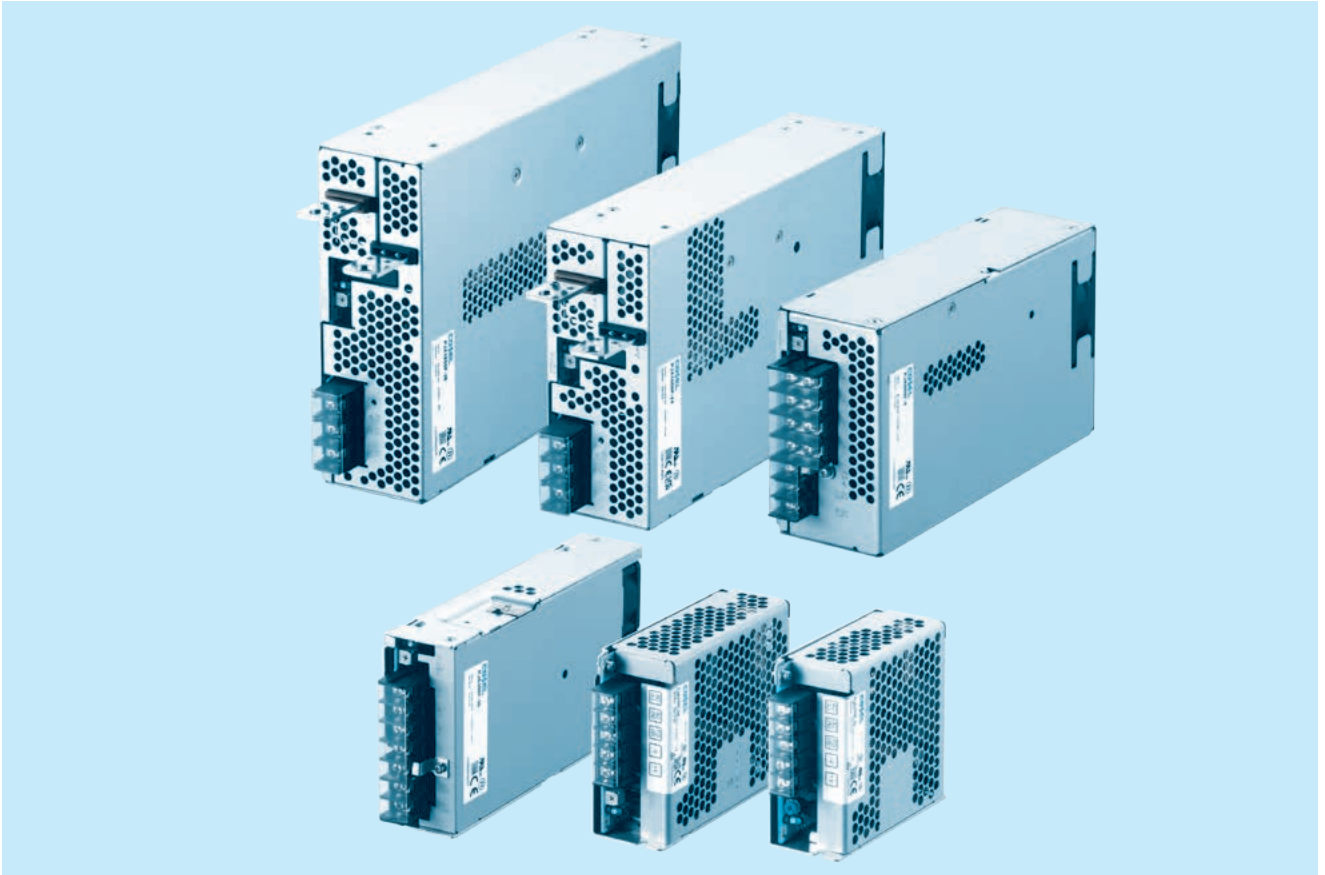

Feature

Low Profile (PJA100F, 150F, 300F : 1U size)
(PJA600F, 1000F, 1500F : 2U size)
Wide temperature range (-20°C to +70°C, Derating is required)
Harmonic attenuator (Complies with IEC61000-3-2 class A)
Universal input (AC85 - 264V, Derating is required)
Low power consumption at no load
Complies with SEMI F-47 (PJA1000F, 1500F can meet at 200V input range only)
Many optional functions

Safety agency approvals

UL62368-1, C-UL (CSA62368-1), EN62368-1
UL508 (PJA100F, 150F)
Complies with DEN-AN

5-year warranty (See Instruction Manual)

CE marking

Low Voltage Directive
RoHS Directive

UKCA marking

Electrical Equipment Safety Regulations
RoHS Regulations

EMI

Complies with FCC-B, CISPR22-B, EN55011-B, EN55022-B, VCCI-B
(PJA1500F: Class A. In conducted noise, it can meet class B by additional EMI/EMC filter.)

EMS Compliance : EN61204-3, EN61000-6-2

EN61000-4-2
EN61000-4-3
EN61000-4-4
EN61000-4-5
EN61000-4-6
EN61000-4-8
EN61000-4-11

PJA100F

PJ A 100 F -□ -□
 ① ② ③ ④ ⑤ ⑥

PJA

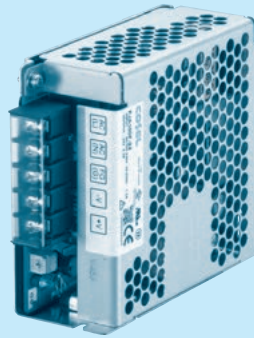

Example recommended EMI/EMC filter
NAC-04-472



High voltage pulse noise type : NAP series
 Low leakage current type : NAM series
 * A higher current rating EMI/EMC filter may be recommended in view of the other devices that could be connected in parallel with the power supply.

- ① Series name
- ② Single output
- ③ Output wattage
- ④ Universal input
- ⑤ Output voltage
- ⑥ Optional *6
- C : with Coating
- R : Remote on/off (Required external power source)
- J : EP (Tyco Electronics) connector type
- J1 : VH (J.S.T.) connector type
- T : Vertical terminal block
- N2 : with DIN rail

See 6.1 in Instruction Manual.

*Make sure necessary tests will be carried out on your end equipment with the power supply installed in accordance with any required EMC/EMI regulations.

SPECIFICATIONS

* Please consider "PBA100F-5-N" about 5V output with case cover.

MODEL		PJA100F-12	PJA100F-15	PJA100F-24	PJA100F-36	PJA100F-48
VOLTAGE[V]		AC85 - 264 1 φ (Output derating is required at AC85V - 115V. Refer to "Derating" and instruction manual 1.1, 3)				
CURRENT[A]	ACIN 100V	1.2typ (Io=90%)				
	ACIN 115V	1.1typ (Io=100%)				
	ACIN 230V	0.6typ (Io=100%)				
FREQUENCY[Hz]		50 / 60 (47 - 63)				
EFFICIENCY[%]	ACIN 100V	82typ (Io=90%)	83typ (Io=90%)	85typ (Io=90%)	86typ (Io=90%)	86typ (Io=90%)
	ACIN 115V	82typ (Io=100%)	83typ (Io=100%)	85typ (Io=100%)	86typ (Io=100%)	86typ (Io=100%)
	ACIN 230V	85typ (Io=100%)	86typ (Io=100%)	88typ (Io=100%)	89typ (Io=100%)	89typ (Io=100%)
POWER FACTOR	ACIN 100V	0.98typ (Io=90%)				
	ACIN 115V	0.98typ (Io=100%)				
	ACIN 230V	0.90typ (Io=100%) * Power factor correction is stopped at AC250V or more.				
INRUSH CURRENT[A]	ACIN 100V	16typ (Io=90%) Ta=25°C at cold start				
	ACIN 115V	16typ (Io=100%) Ta=25°C at cold start				
	ACIN 230V	32typ (Io=100%) Ta=25°C at cold start				
LEAKAGE CURRENT[ma]		0.75max (ACIN 240V, 60Hz, Io=100%. According to IEC62368-1 and DEN-AN)				
VOLTAGE[V]		12	15	24	36	48
CURRENT[A]	ACIN 85-115V	Output derating is required at ACIN 115V or less (Refer to "Derating")				
	ACIN 115V-264V	8.4	6.7	4.3	2.8	2.1
WATTAGE[W]		Output derating is required at ACIN 115V or less (Refer to "Derating")				
ACIN 85-115V		100.8	100.5	103.2	100.8	100.8
ACIN 115V-264V		100.8	100.5	103.2	100.8	100.8
LINE REGULATION[mV] *3		48max	60max	96max	144max	192max
LOAD REGULATION [mV] *3	Io=30 to 100%	100max	120max	150max	150max	300max
	Io=0 to 30%	Burst operation (Please contact us about detail)				
RIPPLE[mVp-p] *1	0 to +40°C	120max	120max	120max	150max	150max
	-10 to 0°C	160max	160max	160max	200max	400max
	Io: load factor	500max	500max	500max	500max	500max
RIPPLE NOISE[mVp-p] *1	0 to +40°C	150max	150max	150max	200max	200max
	-10 to 0°C	180max	180max	180max	240max	500max
	Io: load factor	600max	600max	600max	600max	600max
TEMPERATURE REGULATION[mV]	0 to +40°C	120max	150max	240max	360max	480max
	-10 to +40°C	180max	180max	290max	440max	600max
DRIFT[mV] *2		48max	60max	96max	144max	192max
START-UP TIME[ms]		500typ (ACIN 115V, Io=100%) Ta=25°C				
HOLD-UP TIME[ms]		20typ (ACIN 115V, Io=100%)				
OUTPUT VOLTAGE ADJUSTMENT RANGE[V]		10.80 to 13.20	13.50 to 16.50	21.60 to 26.40	32.40 to 39.60	43.20 to 52.80
OUTPUT VOLTAGE SETTING[V]		12.00 to 12.48	15.00 to 15.60	24.00 to 24.96	36.00 to 37.44	48.00 to 49.92
PROTECTION CIRCUIT AND OTHERS	OVERCURRENT PROTECTION	Works over 105% of rating and recovers automatically				
	OVERVOLTAGE PROTECTION[V]	13.80 to 16.80	17.25 to 21.00	27.60 to 33.60	41.40 to 50.40	54.00 to 67.20
	OPERATING INDICATION	LED (Green)				
	REMOTE SENSING	Not provided				
REMOTE ON/OFF		Optional (Required external power source. Option -R)				
ISOLATION	INPUT-OUTPUT • RC *8	AC3,000V 1minute, Cutoff current = 10mA, DC500V 50MΩ min (At room temperature)				
	INPUT-FG	AC2,000V 1minute, Cutoff current = 10mA, DC500V 50MΩ min (At room temperature)				
	OUTPUT • RC-FG *8	AC500V 1minute, Cutoff current = 100mA, DC500V 50MΩ min (At room temperature)				
	OUTPUT-RC *8	AC500V 1minute, Cutoff current = 100mA, DC500V 50MΩ min (At room temperature)				
ENVIRONMENT	OPERATING TEMP., HUMID. AND ALTITUDE *4	-20 to +70°C (Refer to "Derating"), 20 - 90%RH (Non condensing), 3,000m (10,000 feet) max				
	STORAGE TEMP., HUMID. AND ALTITUDE	-20 to +75°C, 20 - 90%RH (Non condensing), 9,000m (30,000 feet) max				
	VIBRATION	10 - 55Hz, 19.6m/s ² (2G), 3minutes period, 60minutes each along X, Y and Z axes				
	IMPACT	196.1m/s ² (20G), 11ms, once each X, Y and Z axes				
SAFETY AND NOISE REGULATIONS	AGENCY APPROVALS	UL62368-1, C-UL (CSA62368-1), EN62368-1, UL508 (Except option -J, -J1) Complies with DEN-AN				
	CONDUCTED NOISE	Complies with FCC-B, VCCI-B, CISPR22-B, EN55011-B, EN55022-B				
	HARMONIC ATTENUATOR *7	Complies with IEC61000-3-2 class A				

SPECIFICATIONS

OTHERS	CASE SIZE/WEIGHT	41 X 97 X 109mm [1.61 X 3.82 X 4.29 inches] (Excluding terminal block and screw) (W X H X D) / 500g max
	COOLING METHOD	Convection
WARRANTY	WARRANTY	*5 5 years (subject to the operating conditions)

- *1 This is the result of measurement of the testing board with capacitors of 22 μ F and 0.1 μ F placed at 150 mm from the output terminals by a 20 MHz oscilloscope or a ripple-noise meter equivalent to Keisoku-Giken RM103. See 1.6 of Instruction Manual for more details. When the load factor is 0 - 30%, the switching power loss is reduced by burst operation, which will cause ripple and ripple noise to go beyond the specifications.
- *2 Drift is the change in DC output for an eight hour period after a half-hour warm-up at 25°C.
- *3 Consult us about dynamic load and input response. Measure the output voltage by using the average mode of the tester to deal with the burst operation at 30% load or less.
- *4 Output power derating is required. Refer to "Derating".
- *5 See 4 in Instruction Manual for more details.
- *6 Consult us about safety agency approvals for the models with optional functions.
- *7 Consult us about other classes.
- *8 The RC terminal is added to option -R models. The RC terminal is isolated from input, output, and FG.
- * Do not use the power supply in overcurrent conditions or in unspecified input voltage ranges. Otherwise the internal components may be damaged.
- * Parallel operation is not possible with this mode.
- * Sound noise may be heard from the power supply when used for pulse load.

Features

- Compact design (Depth: 109mm 4.29inches)
- High efficiency (88%typ PJA100F-24, AC230Vin, 100% load)
- Low power consumption (1.5W typ AC240Vin, no load at standard model)
- UL508 approved (Except option -J, -J1), and complies with SEMI F47 (see instruction manual 1.1)
- Various connection interface options (vertical terminal [-T], AMP connector [-J], [-J1])

Block diagram

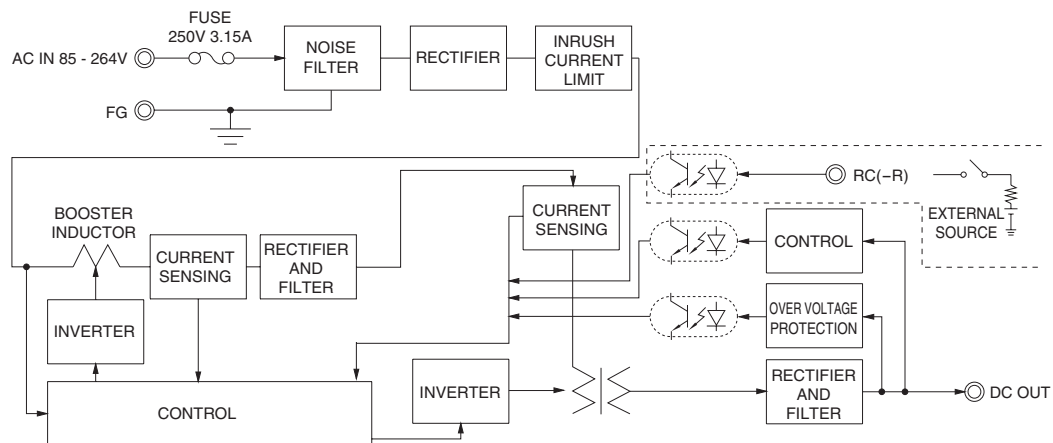

External view

The external size of -R option, -J option, -J1 option, -N2 option and -T option models is different from the standard model. See "6. Options and Others" in Instruction Manual for more details.

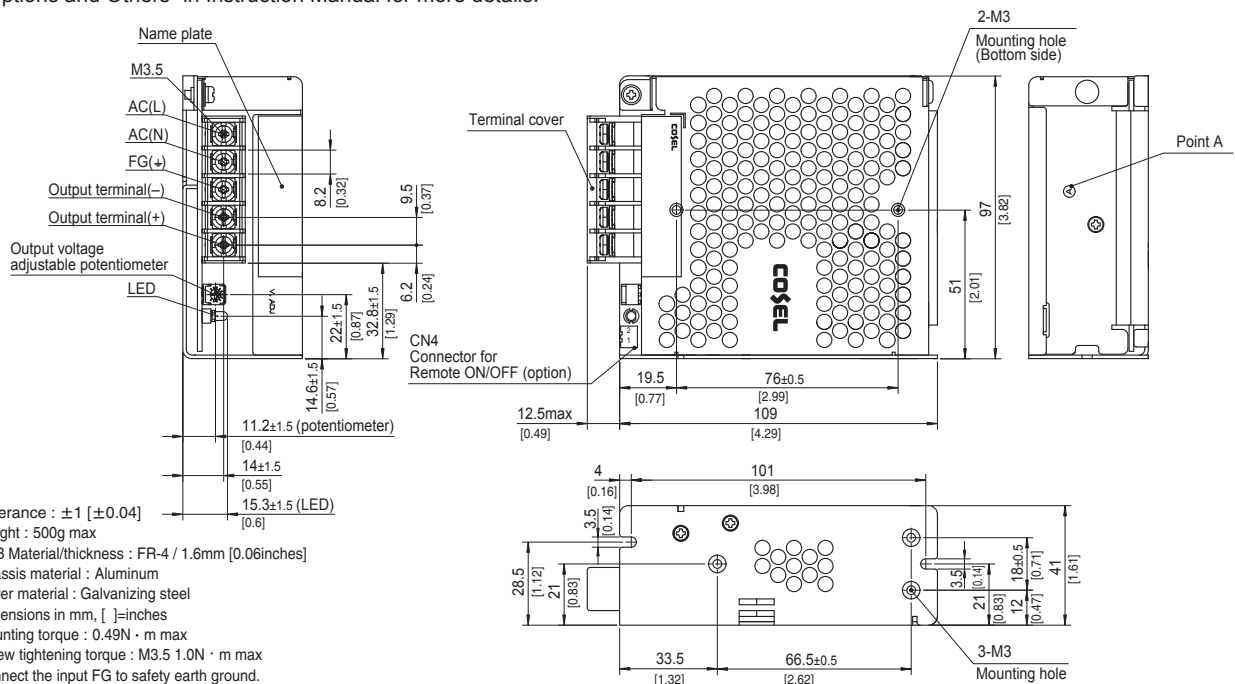

- * Tolerance : ± 1 [± 0.04]
- * Weight : 500g max
- * PCB Material/thickness : FR-4 / 1.6mm [0.06inches]
- * Chassis material : Aluminum
- * Cover material : Galvanizing steel
- * Dimensions in mm, []=inches
- * Mounting torque : 0.49N · m max
- * Screw tightening torque : M3.5 1.0N · m max
- * Connect the input FG to safety earth ground.

PJA150F

PJ A 150 F -□ -□

① ② ③ ④ ⑤ ⑥

PJA



Example recommended EMI/EMC filter
NAC-04-472



High voltage pulse noise type : NAP series
Low leakage current type : NAM series
* A higher current rating EMI/EMC filter may be recommended in view of the other devices that could be connected in parallel with the power supply.

- ① Series name
- ② Single output
- ③ Output wattage
- ④ Universal input
- ⑤ Output voltage
- ⑥ Optional *6
- C : with Coating
- R : Remote on/off (Required external power source)
- J : EP (Tyco Electronics) connector type
- J1 : VH (J.S.T.) connector type
- T : Vertical terminal block
- N2 : with DIN rail

See 6.1 in Instruction Manual.

*Make sure necessary tests will be carried out on your end equipment with the power supply installed in accordance with any required EMC/EMI regulations.

SPECIFICATIONS

* Please consider "PBA150F-5-N" about 5V output with case cover.

MODEL		PJA150F-12	PJA150F-15	PJA150F-24	PJA150F-36	PJA150F-48
VOLTAGE[V]		AC85 - 264 1 φ (Output derating is required at AC85V - 115V. Refer to "Derating" and instruction manual 1.1, 3)				
CURRENT[A]	ACIN 100V	1.7typ (Io=90%)				
	ACIN 115V	1.6typ (Io=100%)				
	ACIN 230V	0.8typ (Io=100%)				
FREQUENCY[Hz]		50 / 60 (47 - 63)				
EFFICIENCY[%]	ACIN 100V	84typ (Io=90%)	84typ (Io=90%)	87typ (Io=90%)	87typ (Io=90%)	87typ (Io=90%)
	ACIN 115V	84typ (Io=100%)	84typ (Io=100%)	87typ (Io=100%)	87typ (Io=100%)	87typ (Io=100%)
	ACIN 230V	87typ (Io=100%)	87typ (Io=100%)	90typ (Io=100%)	90typ (Io=100%)	90typ (Io=100%)
POWER FACTOR	ACIN 100V	0.98typ (Io=90%)				
	ACIN 115V	0.98typ (Io=100%)				
	ACIN 230V	0.93typ (Io=100%) * Power factor correction is stopped at AC250V or more.				
INRUSH CURRENT[A]	ACIN 100V	16typ (Io=90%) Ta=25°C at cold start				
	ACIN 115V	16typ (Io=100%) Ta=25°C at cold start				
	ACIN 230V	32typ (Io=100%) Ta=25°C at cold start				
LEAKAGE CURRENT[ma]		0.75max (ACIN 240V, 60Hz, Io=100%. According to IEC62368-1 and DEN-AN)				
VOLTAGE[V]		12	15	24	36	48
CURRENT[A]	ACIN 85-115V	Output derating is required at ACIN 115V or less (Refer to "Derating")				
	ACIN 115V-264V	12.5	10	6.4	4.2	3.2
WATTAGE[W]	ACIN 85-115V	Output derating is required at ACIN 115V or less (Refer to "Derating")				
	ACIN 115V-264V	150.0	150.0	153.6	151.2	153.6
LINE REGULATION[mV] *3		48max	60max	96max	144max	192max
LOAD REGULATION [mV] *3	Io=30 to 100%	100max	120max	150max	150max	300max
	Io=0 to 30%	Burst operation (Please contact us about detail)				
RIPPLE[mVp-p] *1	0 to +40°C	120max	120max	120max	150max	150max
	-10 to 0°C	160max	160max	160max	200max	400max
	Io: load factor	500max	500max	500max	500max	500max
RIPPLE NOISE[mVp-p] *1	0 to +40°C	150max	150max	150max	200max	200max
	-10 to 0°C	180max	180max	180max	240max	500max
	Io: load factor	600max	600max	600max	600max	600max
TEMPERATURE REGULATION[mV]	0 to +40°C	120max	150max	240max	360max	480max
	-10 to +40°C	180max	180max	290max	440max	600max
DRIFT[mV] *2		48max	60max	96max	144max	192max
START-UP TIME[ms]		500typ (ACIN 115V, Io=100%) Ta=25°C				
HOLD-UP TIME[ms]		20typ (ACIN 115V, Io=100%)				
OUTPUT VOLTAGE ADJUSTMENT RANGE[V]		10.80 to 13.20	13.50 to 16.50	21.60 to 26.40	32.40 to 39.60	43.20 to 52.80
OUTPUT VOLTAGE SETTING[V]		12.00 to 12.48	15.00 to 15.60	24.00 to 24.96	36.00 to 37.44	48.00 to 49.92
OVERCURRENT PROTECTION		Works over 105% of rating and recovers automatically				
OVERVOLTAGE PROTECTION[V]		13.80 to 16.80	17.25 to 21.00	27.60 to 33.60	41.40 to 50.40	54.00 to 67.20
OPERATING INDICATION		LED (Green)				
REMOTE SENSING		Not provided				
REMOTE ON/OFF		Optional (Required external power source. Option -R)				
ISOLATION	INPUT-OUTPUT • RC *8	AC3,000V 1minute, Cutoff current = 10mA, DC500V 50MΩ min (At room temperature)				
	INPUT-FG	AC2,000V 1minute, Cutoff current = 10mA, DC500V 50MΩ min (At room temperature)				
	OUTPUT • RC-FG *8	AC500V 1minute, Cutoff current = 100mA, DC500V 50MΩ min (At room temperature)				
	OUTPUT-RC *8	AC500V 1minute, Cutoff current = 100mA, DC500V 50MΩ min (At room temperature)				
ENVIRONMENT	OPERATING TEMP.,HUMID.AND ALTITUDE *4	-20 to +70°C (Refer to "Derating"), 20 - 90%RH (Non condensing), 3,000m (10,000 feet) max				
	STORAGE TEMP.,HUMID.AND ALTITUDE	-20 to +75°C, 20 - 90%RH (Non condensing), 9,000m (30,000 feet) max				
	VIBRATION	10 - 55Hz, 19.6m/s ² (2G), 3minutes period, 60minutes each along X, Y and Z axes				
IMPACT		196.1m/s ² (20G), 11ms, once each X, Y and Z axes				
SAFETY AND NOISE REGULATIONS	AGENCY APPROVALS	UL62368-1, C-UL (CSA62368-1), EN62368-1, UL508 (Except option -J, -J1) Complies with DEN-AN				
	CONDUCTED NOISE	Complies with FCC-B, VCCI-B, CISPR22-B, EN55011-B, EN55022-B				
	HARMONIC ATTENUATOR *7	Complies with IEC61000-3-2 class A				

SPECIFICATIONS

OTHERS	CASE SIZE/WEIGHT	41 X 97 X 129mm [1.61 X 3.82 X 5.08 inches] (Excluding terminal block and screw) (W X H X D) / 600g max
	COOLING METHOD	Convection
WARRANTY	WARRANTY	*5 5 years (subject to the operating conditions)

*1 This is the result of measurement of the testing board with capacitors of 22 μ F and 0.1 μ F placed at 150 mm from the output terminals by a 20 MHz oscilloscope or a ripple-noise meter equivalent to Keisoku-Giken RM103.
See 1.6 of Instruction Manual for more details.
When the load factor is 0 - 30%, the switching power loss is reduced by burst operation, which will cause ripple and ripple noise to go beyond the specifications.
*2 Drift is the change in DC output for an eight hour period after a half-

hour warm-up at 25°C.
*3 Consult us about dynamic load and input response. Measure the output voltage by using the average mode of the tester to deal with the burst operation at 30% load or less.
*4 Output power derating is required. Refer to "Derating".
*5 See 4 in Instruction Manual for more details.
*6 Consult us about safety agency approvals for the models with optional functions.
*7 Consult us about other classes.
*8 The RC terminal is added to option -R models. The RC terminal is

isolated from input, output, and FG.
* Do not use the power supply in overcurrent conditions or in unspecified input voltage ranges. Otherwise the internal components may be damaged.
* Parallel operation is not possible with this mode.
* Sound noise may be heard from the power supply when used for pulse load.

Features

- Compact design (Depth: 129mm 5.08inches)
- High efficiency (90%typ PJA150F-24, AC230Vin, 100% load)
- Low power consumption (1.5W typ AC240Vin, no load at standard model)
- UL508 approved (Except option -J, -J1), and complies with SEMI F47 (see instruction manual 1.1)
- Various connection interface options (vertical terminal [-T], AMP connector [-J], [-J1])

Block diagram

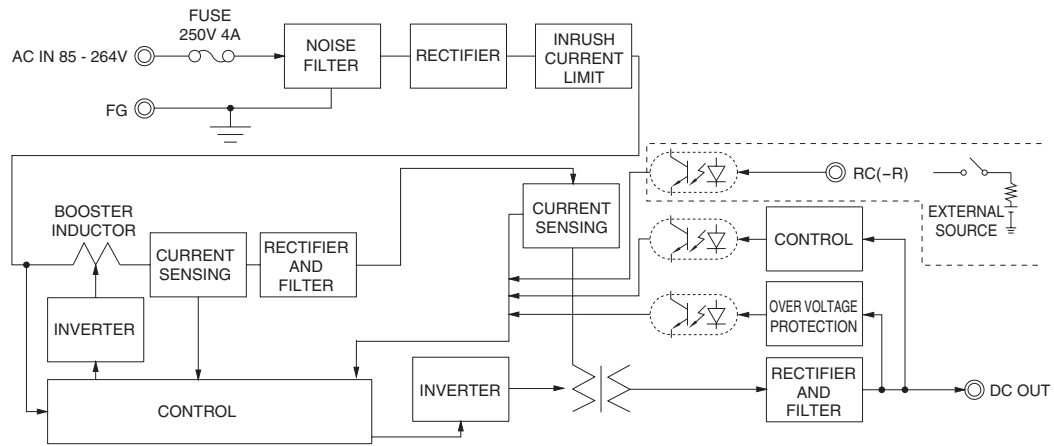

External view

The external size of -R option, -J option, -J1 option, -N2 option and -T option models is different from the standard model. See "6. Options and Others" in Instruction Manual for more details.

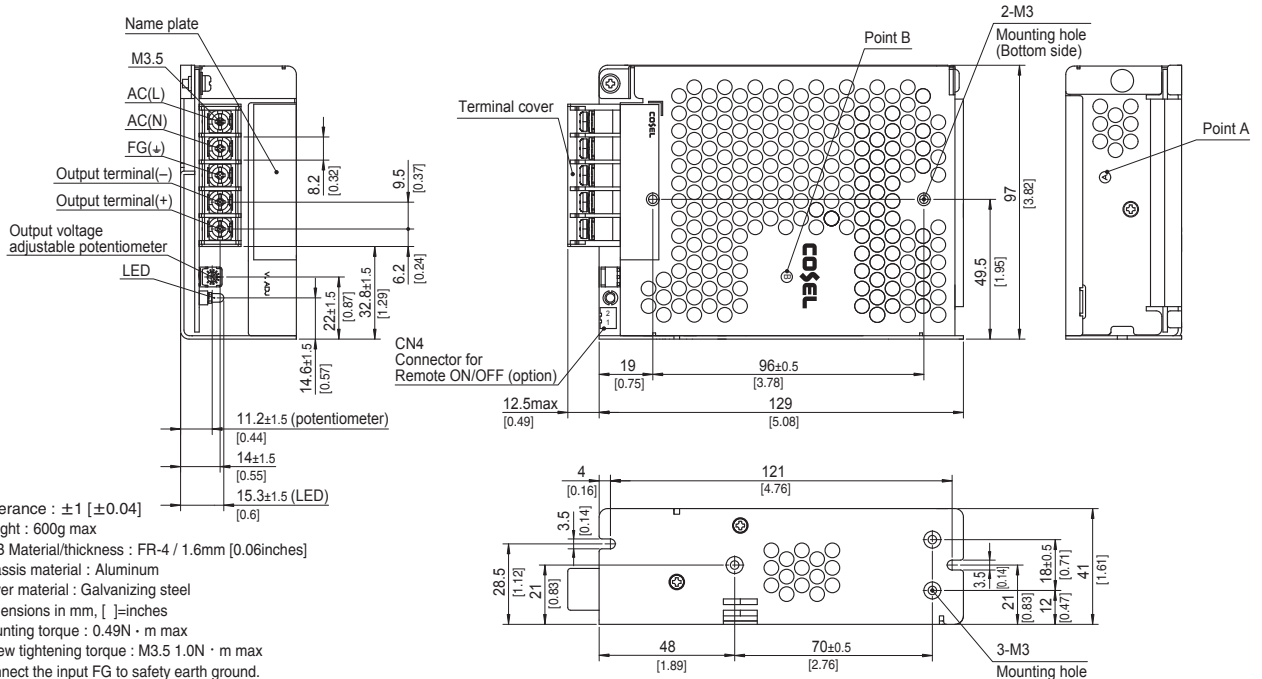

- ※ Tolerance : ± 1 [± 0.04]
- ※ Weight : 600g max
- ※ PCB Material/thickness : FR-4 / 1.6mm [0.06inches]
- ※ Chassis material : Aluminum
- ※ Cover material : Galvanizing steel
- ※ Dimensions in mm, []=inches
- ※ Mounting torque : 0.49N · m max
- ※ Screw tightening torque : M3.5 1.0N · m max
- ※ Connect the input FG to safety earth ground.

PJA300F

PJ A 300 F -□ -□

① ② ③ ④ ⑤ ⑥

PJA

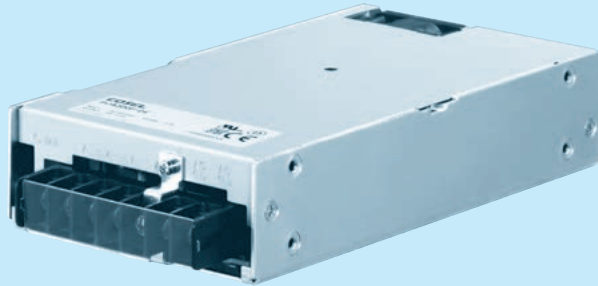

Example recommended EMI/EMC filter
NAC-06-472



High voltage pulse noise type : NAP series
Low leakage current type : NAM series
* A higher current rating EMI/EMC filter may be recommended in view of the other devices that could be connected in parallel with the power supply.

- ① Series name
- ② Single output
- ③ Output wattage
- ④ Universal input
- ⑤ Output voltage
- ⑥ Optional *6
- C : with Coating
- G : Low leakage current
- V : External potentiometer for output voltage adjustment
- R : Remote on/off (Required external power source)
- F4: Low speed fan

See 6.1 in Instruction Manual.

*Make sure necessary tests will be carried out on your end equipment with the power supply installed in accordance with any required EMC/EML regulations.

SPECIFICATIONS

	MODEL	PJA300F-5	PJA300F-12	PJA300F-15	PJA300F-24	PJA300F-36	PJA300F-48	
INPUT	VOLTAGE[V]	AC85 - 264 1 φ (Output derating is required at AC85V - 100V. Refer to "Derating" and instruction manual 1.1, 3)						
	CURRENT[A]	ACIN 100V	3.5typ (Io=100%)	3.9typ (Io=100%)				
		ACIN 115V	3.0typ (Io=100%)	3.3typ (Io=100%)				
		ACIN 230V	1.5typ (Io=100%)	1.7typ (Io=100%)				
	FREQUENCY[Hz]	50 / 60 (47 - 63)						
	EFFICIENCY[%]	ACIN 100V	73typ (Io=100%)	79typ (Io=100%)	81typ (Io=100%)	82typ (Io=100%)	83typ (Io=100%)	82typ (Io=100%)
		ACIN 115V	74typ (Io=100%)	80typ (Io=100%)	82typ (Io=100%)	83typ (Io=100%)	83typ (Io=100%)	83typ (Io=100%)
		ACIN 230V	77typ (Io=100%)	82typ (Io=100%)	84typ (Io=100%)	86typ (Io=100%)	87typ (Io=100%)	86typ (Io=100%)
	POWER FACTOR	ACIN 100V	0.99typ (Io=100%)					
		ACIN 115V	0.98typ (Io=100%)					
ACIN 230V		0.95typ (Io=100%)						
INRUSH CURRENT[A]	ACIN 100V	20typ (Io=100%) Ta=25°C at cold start						
	ACIN 115V	20typ (Io=100%) Ta=25°C at cold start						
	ACIN 230V	40typ (Io=100%) Ta=25°C at cold start						
LEAKAGE CURRENT[ma]	0.75max (ACIN 240V, 60Hz, Io=100%, According to IEC62368-1 and DEN-AN)							
OUTPUT	VOLTAGE[V]	5	12	15	24	36	48	
	CURRENT[A]	ACIN 85-100V	Output derating is required at ACIN 100V or less (Refer to "Derating")					
		ACIN 100V-264V	50	25	20	12.5	8.4	6.3
	WATTAGE[W]	ACIN 85-100V	Output derating is required at ACIN 100V or less (Refer to "Derating")					
		ACIN 100V-264V	250	300	300	300	302.4	302.4
	LINE REGULATION[mV]	*3	20max	48max	60max	96max	144max	192max
	LOAD REGULATION[mV]	*3	40max	100max	120max	150max	150max	300max
	RIPPLE[mVp-p]	0 to +50°C	80max	120max	120max	120max	150max	150max
		*1 -10 to 0°C	140max	160max	160max	160max	160max	400max
	RIPPLE NOISE[mVp-p]	0 to +50°C	120max	150max	150max	150max	200max	200max
		*1 -10 to 0°C	160max	180max	180max	180max	240max	500max
	TEMPERATURE REGULATION[mV]	0 to +50°C	50max	120max	150max	240max	360max	480max
		*1 -10 to +50°C	75max	180max	180max	290max	440max	600max
	DRIFT[mV]	*2	20max	48max	60max	96max	144max	192max
	START-UP TIME[ms]		300typ (ACIN 100V, Io=100%)					
HOLD-UP TIME[ms]		20typ (ACIN 100V, Io=100%)						
OUTPUT VOLTAGE ADJUSTMENT RANGE[V]		4.50 to 5.50	10.80 to 13.20	13.50 to 16.50	21.60 to 26.40	32.40 to 39.60	43.20 to 52.80	
OUTPUT VOLTAGE SETTING[V]		5.00 to 5.15	12.00 to 12.48	15.00 to 15.60	24.00 to 24.96	36.00 to 37.44	48.00 to 49.92	
PROTECTION CIRCUIT AND OTHERS	OVERCURRENT PROTECTION	Works over 105% of rating and recovers automatically						
	OVERVOLTAGE PROTECTION[V]	5.75 to 7.00	13.80 to 16.80	17.25 to 21.00	27.60 to 33.60	41.40 to 50.40	55.20 to 67.20	
	OPERATING INDICATION	LED (Green)						
	REMOTE SENSING	Not provided						
REMOTE ON/OFF	Optional (Required external power source. Option -R)							
ISOLATION	INPUT-OUTPUT • RC	*9 AC3,000V 1minute, Cutoff current = 10mA, DC500V 50MΩ min (At room temperature)						
	INPUT-FG	AC2,000V 1minute, Cutoff current = 10mA, DC500V 50MΩ min (At room temperature)						
	OUTPUT • RC-FG	*9 AC500V 1minute, Cutoff current = 100mA, DC500V 50MΩ min (At room temperature)						
	OUTPUT-RC	*9 AC500V 1minute, Cutoff current = 100mA, DC500V 50MΩ min (At room temperature)						
ENVIRONMENT	OPERATING TEMP., HUMID. AND ALTITUDE *4	-20 to +70°C (Refer to "Derating"), 20 - 90%RH (Non condensing), 3,000m (10,000 feet) max						
	STORAGE TEMP., HUMID. AND ALTITUDE	-20 to +75°C, 20 - 90%RH (Non condensing), 9,000m (30,000 feet) max						
	VIBRATION	10 - 55Hz, 19.6m/s ² (2G), 3minutes period, 60minutes each along X, Y and Z axes						
IMPACT	196.1m/s ² (20G), 11ms, once each X, Y and Z axes							
SAFETY AND NOISE REGULATIONS	AGENCY APPROVALS	UL62368-1, C-UL (CSA62368-1), EN62368-1 Complies with DEN-AN						
	CONDUCTED NOISE	Complies with FCC-B, VCCI-B, CISPR22-B, EN55011-B, EN55022-B						
	HARMONIC ATTENUATOR *8	Complies with IEC61000-3-2 class A						

SPECIFICATIONS

OTHERS	CASE SIZE/WEIGHT	102 X 41 X 190mm [4.02 X 1.61 X 7.48 inches] (Excluding terminal block and screw) (W X H X D) / 1.0kg max
	COOLING METHOD	*7 Forced cooling (internal fan)
WARRANTY	WARRANTY	*5 5 years (subject to the operating conditions)

- *1 This is the result of measurement of the testing board with capacitors of 22 μF and 0.1 μF placed at 150 mm from the output terminals by a 20 MHz oscilloscope or a ripple-noise meter equivalent to Keisoku-Giken RM103. See 1.6 of Instruction Manual for more details.
- *2 Drift is the change in DC output for an eight hour period after a half-hour warm-up at 25°C.
- *3 Consult us about dynamic load and input response.
- *4 Output power derating is required. Refer to "Derating".
- *5 See 4 in Instruction Manual for more details.
- *6 Consult us about safety agency approvals for the models with optional functions.
- *7 The fan speed slows down at no load.
- *8 Consult us about other classes.
- *9 The RC terminal is added to option -R models. The RC terminal is isolated from input, output, and FG.
- * Do not use the power supply in overcurrent conditions or in unspecified input voltage ranges. Otherwise the internal components may be damaged.
- * Parallel operation is not possible with this mode.
- * Sound noise may be heard from the power supply when used for pulse load.

Features

- Cost-effective
- Longer life (see Instruction Manual)
- Low profile (meets 1U height = 41 mm or 1.61 inches)
- Wide operating temperature range (-20°C to +70°C Refer to "Derating")
- Slow fan speed at no load
- Complies with SEMI F-47
- Many optional functions

Block diagram

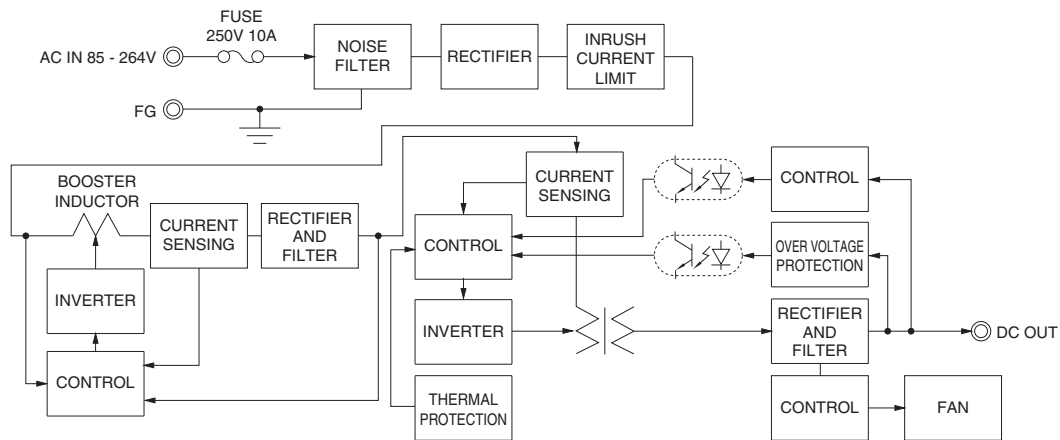

External view

The external size of -V option and -R option models is different from the standard model. See "6. Options and Others" in Instruction Manual for more details.

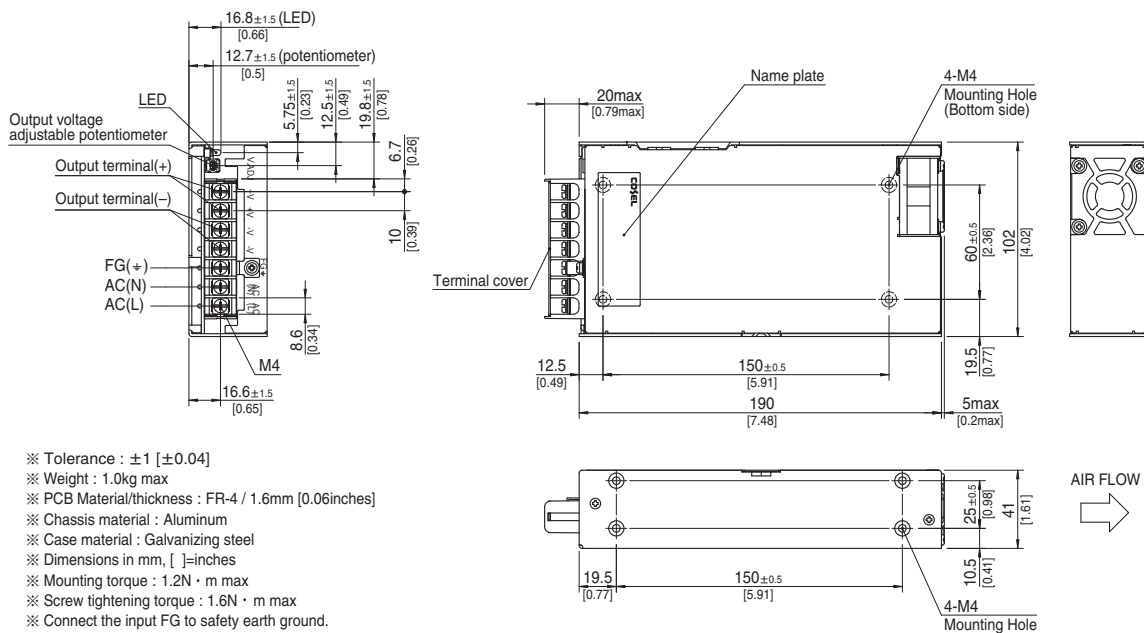

PJA600F

PJ A 600 F - □ - □

① ② ③ ④ ⑤ ⑥

PJA

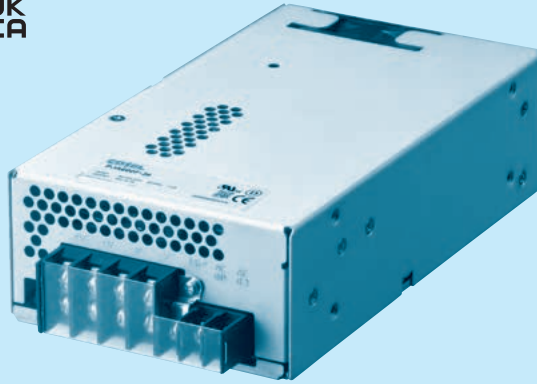

Example recommended EMI/EMC filter
NAC-16-472



High voltage pulse noise type : NAP series
Low leakage current type : NAM series
* A higher current rating EMI/EMC filter may be recommended in view of the other devices that could be connected in parallel with the power supply.

- ① Series name
- ② Single output
- ③ Output wattage
- ④ Universal input
- ⑤ Output voltage
- ⑥ Optional *6
- C : with Coating
- G : Low leakage current
- V : External potentiometer for output voltage adjustment
- W: Parallel operation, LV alarm and Remote sensing
- R : Remote on/off (Required external power source)
- F4: Low speed fan

See 6.1 in Instruction Manual.

*Make sure necessary tests will be carried out on your end equipment with the power supply installed in accordance with any required EMC/EMI regulations.

SPECIFICATIONS

	MODEL	PJA600F-5	PJA600F-12	PJA600F-15	PJA600F-24	PJA600F-36	PJA600F-48	
INPUT	VOLTAGE[V]	AC85 - 264 1 φ (Output derating is required at AC85V - 100V. Refer to "Derating" and instruction manual 1.1, 3)						
	CURRENT[A]	ACIN 100V	6.7typ (Io=100%)	7.5typ (Io=100%)				
		ACIN 115V	5.7typ (Io=100%)	6.5typ (Io=100%)				
		ACIN 230V	2.8typ (Io=100%)	3.2typ (Io=100%)				
	FREQUENCY[Hz]	50 / 60 (47 - 63)						
	EFFICIENCY[%]	ACIN 100V	76typ (Io=100%)	81typ (Io=100%)	82typ (Io=100%)	84typ (Io=100%)	85typ (Io=100%)	85typ (Io=100%)
		ACIN 115V	77typ (Io=100%)	82typ (Io=100%)	82typ (Io=100%)	85typ (Io=100%)	86typ (Io=100%)	85typ (Io=100%)
		ACIN 230V	79typ (Io=100%)	84typ (Io=100%)	85typ (Io=100%)	88typ (Io=100%)	88typ (Io=100%)	88typ (Io=100%)
	POWER FACTOR	ACIN 100V	0.99typ (Io=100%)					
		ACIN 115V	0.98typ (Io=100%)					
ACIN 230V		0.95typ (Io=100%)						
INRUSH CURRENT[A]	ACIN 100V	20/40typ (Io=100%) (Primary inrush current /Secondary inrush current) (More than 3sec to re-start)						
	ACIN 115V	20/40typ (Io=100%) (Primary inrush current /Secondary inrush current) (More than 3sec to re-start)						
	ACIN 230V	40/40typ (Io=100%) (Primary inrush current /Secondary inrush current) (More than 3sec to re-start)						
LEAKAGE CURRENT[ma]	1.5max (ACIN 240V, 60Hz, Io=100%, According to IEC62368-1 and DEN-AN)							
OUTPUT	VOLTAGE[V]	5	12	15	24	36	48	
	CURRENT[A]	ACIN 85-100V	Output derating is required at ACIN 100V or less (Refer to "Derating")					
		ACIN 100V-264V	100	50	40	25	16.7	12.5
	WATTAGE[W]	ACIN 85-100V	Output derating is required at ACIN 100V or less (Refer to "Derating")					
		ACIN 100V-264V	500	600	600	600	601.2	600
	LINE REGULATION[mV]	*7	20max	48max	60max	96max	144max	192max
	LOAD REGULATION[mV]	*7	40max	100max	120max	150max	150max	300max
	RIPPLE[mVp-p]	0 to +50°C	80max	120max	120max	120max	150max	150max
		-20 to 0°C	140max	160max	160max	160max	160max	400max
	RIPPLE NOISE[mVp-p]	0 to +50°C	120max	150max	150max	150max	200max	200max
		-20 to 0°C	160max	180max	180max	180max	240max	500max
	TEMPERATURE REGULATION[mV]	0 to +50°C	50max	120max	150max	240max	360max	480max
		-20 to +50°C	75max	180max	180max	290max	440max	600max
	DRIFT[mV]	*2	20max	48max	60max	96max	144max	192max
	START-UP TIME[ms]	300typ (ACIN 100V, Io=100%)						
	HOLD-UP TIME[ms]	20typ (ACIN 100V, Io=100%)						
	OUTPUT VOLTAGE ADJUSTMENT RANGE[V]	4.50 to 5.50		10.80 to 13.20	13.50 to 16.50	21.60 to 26.40	32.40 to 39.60	43.20 to 52.80
OUTPUT VOLTAGE SETTING[V]	5.00 to 5.15		12.00 to 12.48	15.00 to 15.60	24.00 to 24.96	36.00 to 37.44	48.00 to 49.92	
PROTECTION CIRCUIT AND OTHERS	OVERCURRENT PROTECTION	Works over 105% of rating and recovers automatically						
	OVERVOLTAGE PROTECTION[V]	5.75 to 7.00	13.80 to 16.80	17.25 to 21.00	27.60 to 33.60	41.40 to 50.40	55.20 to 67.20	
	OPERATING INDICATION	LED (Green)						
	REMOTE SENSING	Optional (Option -W)						
REMOTE ON/OFF	Optional (Required external power source. Option -R)							
ISOLATION	INPUT-OUTPUT • RC	*3 AC3,000V 1minute, Cutoff current = 10mA, DC500V 50MΩ min (At room temperature)						
	INPUT-FG	AC2,000V 1minute, Cutoff current = 10mA, DC500V 50MΩ min (At room temperature)						
	OUTPUT • RC-FG	*3 AC500V 1minute, Cutoff current = 100mA, DC500V 50MΩ min (At room temperature)						
	OUTPUT-RC	*3 AC500V 1minute, Cutoff current = 100mA, DC500V 50MΩ min (At room temperature)						
ENVIRONMENT	OPERATING TEMP., HUMID. AND ALTITUDE *4	-20 to +70°C (Refer to "Derating"), 20 - 90%RH (Non condensing), 3,000m (10,000 feet) max						
	STORAGE TEMP., HUMID. AND ALTITUDE	-20 to +75°C, 20 - 90%RH (Non condensing), 9,000m (30,000 feet) max						
	VIBRATION	10 - 55Hz, 19.6m/s ² (2G), 3minutes period, 60minutes each along X, Y and Z axes						
SAFETY AND NOISE REGULATIONS	IMPACT	196.1m/s ² (20G), 11ms, once each X, Y and Z axes						
	AGENCY APPROVALS	UL62368-1, C-UL (CSA62368-1), EN62368-1 Complies with DEN-AN						
	CONDUCTED NOISE	Complies with FCC-B, VCCI-B, CISPR22-B, EN55011-B, EN55022-B						
HARMONIC ATTENUATOR *9	Complies with IEC61000-3-2 class A							

SPECIFICATIONS

OTHERS	CASE SIZE/WEIGHT	120×61×215mm [4.72×2.40×8.46 inches] (Excluding terminal block and screw) (W×H×D) / 2.0kg max
	COOLING METHOD	*8 Forced cooling (internal fan)
WARRANTY	WARRANTY	*5 5 years (subject to the operating conditions)

- *1 This is the result of measurement of the testing board with capacitors of 22 μF and 0.1 μF placed at 150 mm from the output terminals by a 20 MHz oscilloscope or a ripple-noise meter equivalent to Keisoku-Giken RM103. See 1.6 of Instruction Manual for more details.
- *2 Drift is the change in DC output for an eight hour period after a half-hour warm-up at 25°C.
- *3 The RC terminal is added to option –R models. The RC terminal is isolated from input, output, and FG.
- *4 Output power derating is required. Refer to “Derating”.
- *5 See 4 in Instruction Manual for more details.
- *6 Consult us about safety agency approvals for the models with optional functions.
- *7 Consult us about dynamic load and input response.
- *8 The fan speed slows down at no load.
- *9 Consult us about other classes.
- * Do not use the power supply in overcurrent conditions or in unspecified input voltage ranges. Otherwise the internal components may be damaged.
- * Parallel operation is allowed for PLA600FA models with the –W option only.
- * Sound noise may be heard from the power supply when used for pulse load.

Features

- Cost-effective
- Longer life (see Instruction Manual)
- Low profile (meets 2U height = 61 mm or 2.40 inches)
- Wide operating temperature range (-20°C to +70°C Refer to “Derating”)
- Slow fan speed at no load
- Complies with SEMI F-47
- Many optional functions

Block diagram

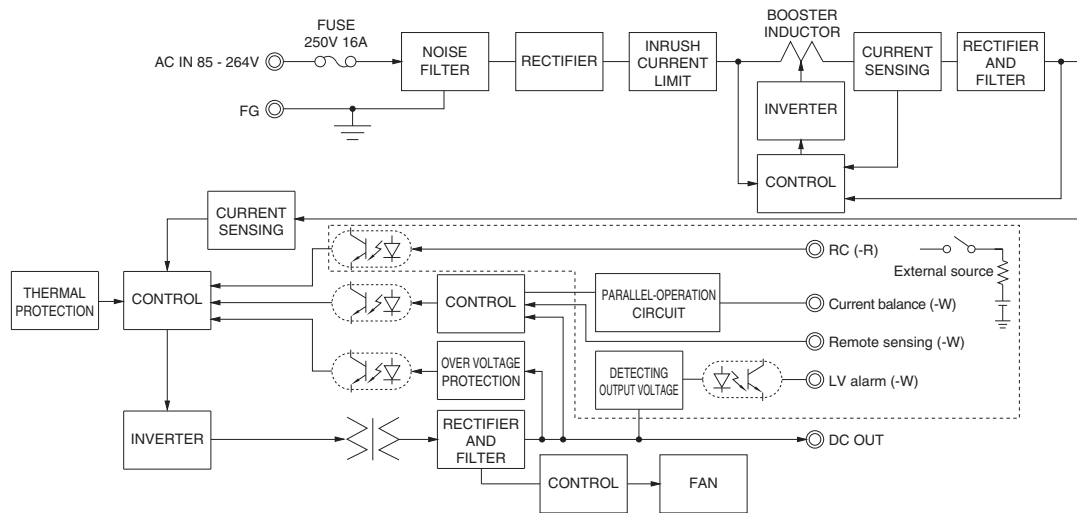

External view

The external size of –V option, –W option and –R option models is different from the standard model. See “6. Options and Others” in Instruction Manual for more details.

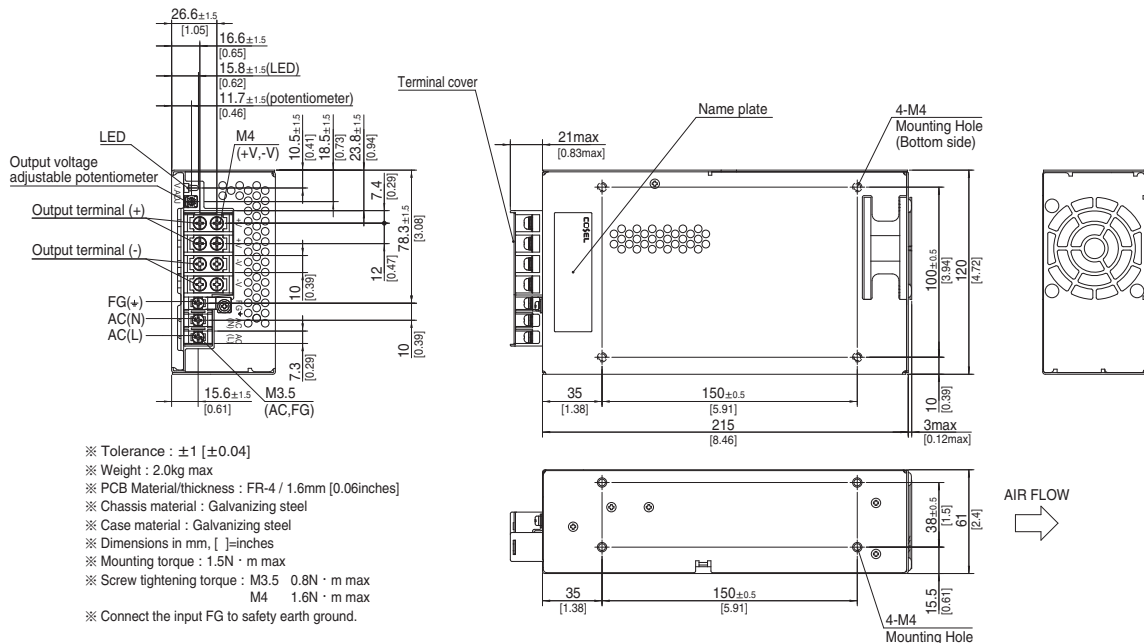

- ※ Tolerance : ±1 [±0.04]
- ※ Weight : 2.0kg max
- ※ PCB Material/thickness : FR-4 / 1.6mm [0.06inches]
- ※ Chassis material : Galvanizing steel
- ※ Case material : Galvanizing steel
- ※ Dimensions in mm, []=inches
- ※ Mounting torque : 1.5N · m max
- ※ Screw tightening torque : M3.5 0.8N · m max
M4 1.6N · m max
- ※ Connect the input FG to safety earth ground.

PJA1000F

① PJ ② A ③ 1000 ④ F ⑤ -□ ⑥ -□

PJA



Example recommended EMI/EMC filter
NAC-20-472



High voltage pulse noise type : NAP series
Low leakage current type : NAM series

- ① Series name
- ② Single output
- ③ Output wattage
- ④ Universal input
- ⑤ Output voltage
- ⑥ Optional *8
- C : with Coating
- G : Low leakage current
- V : External potentiometer for output voltage adjustment
- W : Parallel operation, LV alarm and Remote sensing
- R : Remote on/off (Required external power source)

See 6.1 in Instruction Manual.

*Make sure necessary tests will be carried out on your end equipment with the power supply installed in accordance with any required EMC/EML regulations.

SPECIFICATIONS

	MODEL	PJA1000F-12	PJA1000F-15	PJA1000F-24	PJA1000F-36	PJA1000F-48	
INPUT	VOLTAGE[V]	AC85 - 264 1 φ (Output derating is required at AC85V - 115V. Refer to "Derating" and instruction manual 1.1, 3)					
	CURRENT[A]	ACIN 100V	12.5typ (Io=90%)				
		ACIN 115V	11.0typ (Io=100%)				
		ACIN 230V	5.5typ (Io=100%)				
	FREQUENCY[Hz]	50 / 60 (47 - 63)					
	EFFICIENCY[%]	ACIN 100V	81typ (Io=90%)	82typ (Io=90%)	84typ (Io=90%)	84typ (Io=90%)	84typ (Io=90%)
		ACIN 115V	82typ (Io=100%)	82typ (Io=100%)	85typ (Io=100%)	85typ (Io=100%)	85typ (Io=100%)
		ACIN 230V	85typ (Io=100%)	85typ (Io=100%)	88typ (Io=100%)	88typ (Io=100%)	88typ (Io=100%)
	POWER FACTOR	ACIN 100V	0.98typ (Io=90%)				
		ACIN 115V	0.98typ (Io=100%)				
ACIN 230V		0.95typ (Io=100%)					
INRUSH CURRENT[A]	ACIN 100V	15/30typ (Io=90%) (Primary inrush current /Secondary inrush current) (More than 10sec to re-start)					
	ACIN 115V	15/30typ (Io=100%) (Primary inrush current /Secondary inrush current) (More than 10sec to re-start)					
	ACIN 230V	30/30typ (Io=100%) (Primary inrush current /Secondary inrush current) (More than 10sec to re-start)					
LEAKAGE CURRENT[ma]	1.5max (ACIN 240V, 60Hz, Io=100%, According to IEC62368-1 and DEN-AN)						
OUTPUT	VOLTAGE[V]	12	15	24	36	48	
	CURRENT[A]	ACIN 85-115V	Output derating is required at ACIN 115V or less (Refer to "Derating")				
		ACIN 115V-264V	84	67	42	28	21
	WATTAGE[W]	ACIN 85-115V	Output derating is required at ACIN 115V or less (Refer to "Derating")				
		ACIN 115V-264V	1008	1005	1008	1008	1008
	LINE REGULATION[mV]	*2	48max	60max	96max	144max	192max
	LOAD REGULATION[mV]	*2	100max	120max	150max	150max	300max
	RIPPLE[mVp-p]	0 to +50°C	180max	180max	120max	150max	200max
		*1 -20 to 0°C	240max	240max	160max	200max	500max
	RIPPLE NOISE[mVp-p]	0 to +50°C	210max	210max	150max	200max	300max
		*1 -20 to 0°C	270max	270max	180max	240max	600max
	TEMPERATURE REGULATION[mV]	0 to +50°C	120max	150max	240max	360max	480max
		*1 -20 to +50°C	180max	180max	290max	440max	600max
	DRIFT[mV]	*3	48max	60max	96max	144max	192max
	START-UP TIME[ms]	800typ (ACIN 115V, Io=100%)					
HOLD-UP TIME[ms]	20typ (ACIN 115V, Io=100%)						
OUTPUT VOLTAGE ADJUSTMENT RANGE[V]	10.80 to 13.50	13.50 to 17.30	20.40 to 28.50	30.60 to 40.80	40.80 to 55.20		
OUTPUT VOLTAGE SETTING[V]	12.00 to 12.48	15.00 to 15.60	24.00 to 24.96	36.00 to 37.44	48.00 to 49.92		
PROTECTION CIRCUIT AND OTHERS	OVERCURRENT PROTECTION	Works over 105% of rating and recovers automatically					
	OVERVOLTAGE PROTECTION[V]	14.40 to 17.40	18.00 to 21.80	28.80 to 34.80	43.20 to 52.20	57.00 to 67.20	
	OPERATING INDICATION	LED (Green)					
	REMOTE SENSING	Optional (Option -W)					
	REMOTE ON/OFF	Optional (Required external power source. Option -R)					
ISOLATION	INPUT-OUTPUT	AC3,000V 1minute, Cutoff current = 25mA, DC500V 50MΩ min (At room temperature)					
	INPUT-FG	AC2,000V 1minute, Cutoff current = 25mA, DC500V 50MΩ min (At room temperature)					
	OUTPUT-FG	AC500V 1minute, Cutoff current = 100mA, DC500V 50MΩ min (At room temperature)					
ENVIRONMENT	OPERATING TEMP., HUMID. AND ALTITUDE *4	-20 to +70°C (Refer to "Derating"), 20 - 90%RH (Non condensing), 3,000m (10,000 feet) max					
	STORAGE TEMP., HUMID. AND ALTITUDE	-20 to +75°C, 20 - 90%RH (Non condensing), 9,000m (30,000 feet) max					
	VIBRATION	10 - 55Hz, 19.6m/s ² (2G), 3minutes period, 60minutes each along X, Y and Z axes					
	IMPACT	196.1m/s ² (20G), 11ms, once each X, Y and Z axes					
SAFETY AND NOISE REGULATIONS	AGENCY APPROVALS	UL62368-1, C-UL (CSA62368-1), EN62368-1 Complies with DEN-AN					
	CONDUCTED NOISE	Complies with FCC-B, VCCI-B, CISPR22-B, EN55011-B, EN55022-B					
	HARMONIC ATTENUATOR *5	Complies with IEC61000-3-2 class A					

SPECIFICATIONS

OTHERS	CASE SIZE/WEIGHT	150×61×240mm [5.91×2.40×9.45 inches] (Excluding terminal block and screw) (W×H×D) / 2.8kg max
	COOLING METHOD	*6 Forced cooling (internal fan)
WARRANTY	WARRANTY	*7 5 years (subject to the operating conditions)

- *1 This is the result of measurement of the testing board with capacitors of 22 μF and 0.1 μF placed at 150 mm from the output terminals by a 20 MHz oscilloscope or a ripple-noise meter equivalent to Keisoku-Giken RM103.
See 1.6 of Instruction Manual for more details.
- *2 Consult us about dynamic load and input response.
- *3 Drift is the change in DC output for an eight hour period after a half-hour warm-up at 25°C.
- *4 Output power derating is required. Refer to "Derating".
- *5 Consult us about other classes.
- *6 The fan speed slows down or stops at no load.
- *7 See 4 in Instruction Manual for more details.
- *8 Consult us about safety agency approvals for the models with optional functions.
- * Do not use the power supply in overcurrent conditions or in unspecified input voltage ranges. Otherwise the internal components may be damaged.
- * Parallel operation is not possible with this mode.
- * Audible noise may be heard from the power supply when used for pulse load.

Features

- Cost-effective
- Longer life (see Instruction Manual)
- Low profile (meets 2U height = 61 mm or 2.4 inches)
- Wide operating temperature range (-20°C to +70°C Refer to "Derating")
- Stop or slow fan speed at no load

Block diagram

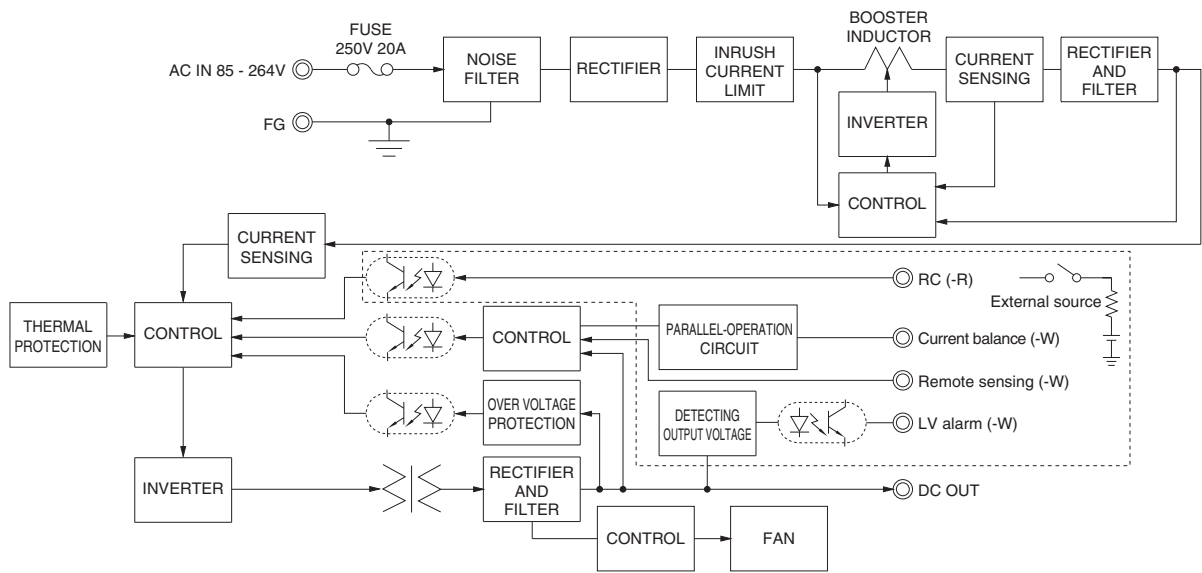

External view

The external size of -V option, -W option and -R option models is different from the standard model. See "6. Options and Others" in Instruction Manual for more details.

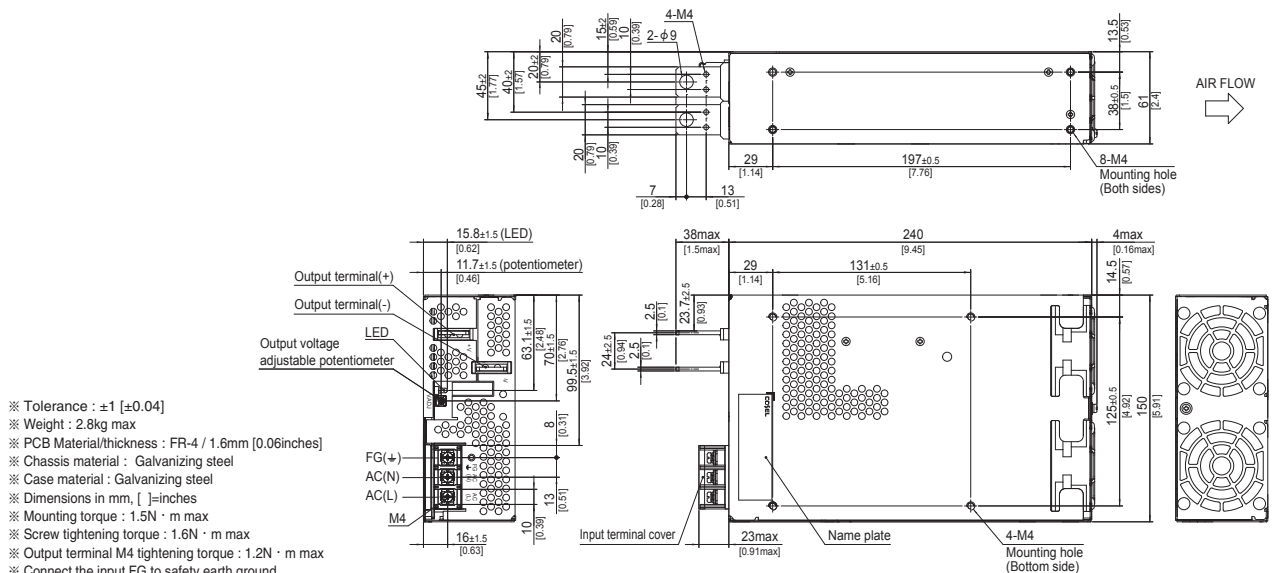

PJA1500F

PJ A 1500 F -□ -□
 ① ② ③ ④ ⑤ ⑥

PJA

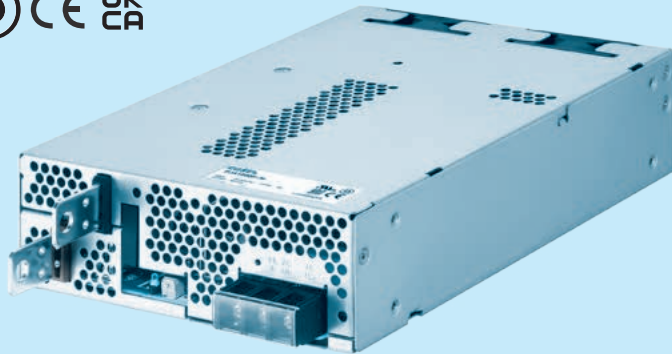

Example recommended EMI/EMC filter
NAC-20-472



High voltage pulse noise type : NAP series
 Low leakage current type : NAM series

- ① Series name
- ② Single output
- ③ Output wattage
- ④ Universal input
- ⑤ Output voltage
- ⑥ Optional *8
- C : with Coating
- G : Low leakage current
- V : External potentiometer for output voltage adjustment
- W : Parallel operation, LV alarm and Remote sensing
- R : Remote on/off (Required external power source)

See 6.1 in Instruction Manual.

*Make sure necessary tests will be carried out on your end equipment with the power supply installed in accordance with any required EMC/EMI regulations.

SPECIFICATIONS

	MODEL	PJA1500F-12	PJA1500F-15	PJA1500F-24	PJA1500F-36	PJA1500F-48	
INPUT	VOLTAGE[V]	AC85 - 264 1 φ (Output derating is required at AC85V - 115V. Refer to "Derating" and instruction manual 1.1, 3)					
	CURRENT[A]	ACIN 100V	18typ (Io=90%)				
		ACIN 115V	16typ (Io=100%)				
		ACIN 230V	8typ (Io=100%)				
	FREQUENCY[Hz]	50 / 60 (47 - 63)					
	EFFICIENCY[%]	ACIN 100V	81typ (Io=90%)	82typ (Io=90%)	84typ (Io=90%)	84typ (Io=90%)	84typ (Io=90%)
		ACIN 115V	82typ (Io=100%)	82typ (Io=100%)	85typ (Io=100%)	85typ (Io=100%)	84typ (Io=100%)
		ACIN 230V	85typ (Io=100%)	85typ (Io=100%)	88typ (Io=100%)	88typ (Io=100%)	87typ (Io=100%)
	POWER FACTOR	ACIN 100V	0.98typ (Io=90%)				
		ACIN 115V	0.98typ (Io=100%)				
ACIN 230V		0.95typ (Io=100%)					
INRUSH CURRENT[A]	ACIN 100V	15/30typ (Io=90%) (Primary inrush current /Secondary inrush current) (More than 10sec to re-start)					
	ACIN 115V	15/30typ (Io=100%) (Primary inrush current /Secondary inrush current) (More than 10sec to re-start)					
	ACIN 230V	30/30typ (Io=100%) (Primary inrush current /Secondary inrush current) (More than 10sec to re-start)					
LEAKAGE CURRENT[ma]	1.5max (ACIN 240V, 60Hz, Io=100%, According to IEC62368-1 and DEN-AN)						
OUTPUT	VOLTAGE[V]	12	15	24	36	48	
	CURRENT[A]	ACIN 85-115V	Output derating is required at ACIN 115V or less (Refer to "Derating")				
		ACIN 115V-264V	125	100	64	42	32
	WATTAGE[W]	ACIN 85-115V	Output derating is required at ACIN 115V or less (Refer to "Derating")				
		ACIN 115V-264V	1500	1500	1536	1512	1536
	LINE REGULATION[mV]	*2	48max	60max	96max	144max	192max
	LOAD REGULATION[mV]	*2	100max	120max	150max	150max	300max
	RIPPLE[mVp-p]	0 to +50°C	180max	180max	120max	150max	200max
		*1 -20 to 0°C	240max	240max	160max	200max	500max
	RIPPLE NOISE[mVp-p]	0 to +50°C	210max	210max	150max	200max	300max
		*1 -20 to 0°C	270max	270max	270max	240max	600max
	TEMPERATURE REGULATION[mV]	0 to +50°C	120max	150max	240max	360max	480max
		*1 -20 to +50°C	180max	180max	290max	440max	600max
	DRIFT[mV]	*3	48max	60max	96max	144max	192max
	START-UP TIME[ms]	800typ (ACIN 115V, Io=100%)					
HOLD-UP TIME[ms]	20typ (ACIN 115V, Io=100%)						
OUTPUT VOLTAGE ADJUSTMENT RANGE[V]	10.80 to 13.50	13.50 to 17.30	20.40 to 28.50	30.60 to 40.80	40.80 to 55.20		
OUTPUT VOLTAGE SETTING[V]	12.00 to 12.48	15.00 to 15.60	24.00 to 24.96	36.00 to 37.44	48.00 to 49.92		
PROTECTION CIRCUIT AND OTHERS	OVERCURRENT PROTECTION	Works over 105% of rating and recovers automatically					
	OVERVOLTAGE PROTECTION[V]	14.40 to 17.40	18.00 to 21.80	28.80 to 34.80	43.20 to 52.20	57.00 to 67.20	
	OPERATING INDICATION	LED (Green)					
	REMOTE SENSING	Optional (Option -W)					
	REMOTE ON/OFF	Optional (Required external power source. Option -R)					
ISOLATION	INPUT-OUTPUT	AC3,000V 1minute, Cutoff current = 25mA, DC500V 50MΩ min (At room temperature)					
	INPUT-FG	AC2,000V 1minute, Cutoff current = 25mA, DC500V 50MΩ min (At room temperature)					
	OUTPUT-FG	AC500V 1minute, Cutoff current = 100mA, DC500V 50MΩ min (At room temperature)					
ENVIRONMENT	OPERATING TEMP., HUMID. AND ALTITUDE *4	-20 to +70°C (Refer to "Derating"), 20 - 90%RH (Non condensing), 3,000m (10,000 feet) max					
	STORAGE TEMP., HUMID. AND ALTITUDE	-20 to +75°C, 20 - 90%RH (Non condensing), 9,000m (30,000 feet) max					
	VIBRATION	10 - 55Hz, 19.6m/s ² (2G), 3minutes period, 60minutes each along X, Y and Z axes					
	IMPACT	196.1m/s ² (20G), 11ms, once each X, Y and Z axes					
SAFETY AND NOISE REGULATIONS	AGENCY APPROVALS	UL62368-1, C-UL (CSA62368-1), EN62368-1, Complies with DEN-AN					
	CONDUCTED NOISE	Complies with FCC-A, VCCI-A, CISPR22-A, EN55011-A, EN55022-A, additional EMI/EMC Filter is required for meeting class B					
	HARMONIC ATTENUATOR *5	Complies with IEC61000-3-2 class A					

SPECIFICATIONS

OTHERS	CASE SIZE/WEIGHT	178×61×268mm [7.01×2.40×10.55 inches] (Excluding terminal block and screw) (W×H×D) / 3.5kg max
	COOLING METHOD	*6 Forced cooling (internal fan)
WARRANTY	WARRANTY	*7 5 years (subject to the operating conditions)

- *1 This is the result of measurement of the testing board with capacitors of 22 μF and 0.1 μF placed at 150 mm from the output terminals by a 20 MHz oscilloscope or a ripple-noise meter equivalent to Keisoku-Giken RM103.
See 1.6 of Instruction Manual for more details.
- *2 Consult us about dynamic load and input response.
- *3 Drift is the change in DC output for an eight hour period after a half-hour warm-up at 25°C.
- *4 Output power derating is required. Refer to "Derating".
- *5 Consult us about other classes.
- *6 The fan speed slows down or stops at no load.
- *7 See 4 in Instruction Manual for more details.
- *8 Consult us about safety agency approvals for the models with optional functions.
- * Do not use the power supply in overcurrent conditions or in unspecified input voltage ranges. Otherwise the internal components may be damaged.
- * Parallel operation is not possible with this mode.
- * Audible noise may be heard from the power supply when used for pulse load.

Features

- Cost-effective
- Longer life (see Instruction Manual)
- Low profile (meets 2U height = 61 mm or 2.4 inches)
- Wide operating temperature range (-20°C to +70°C Refer to "Derating")
- Stop or slow fan speed at no load

Block diagram

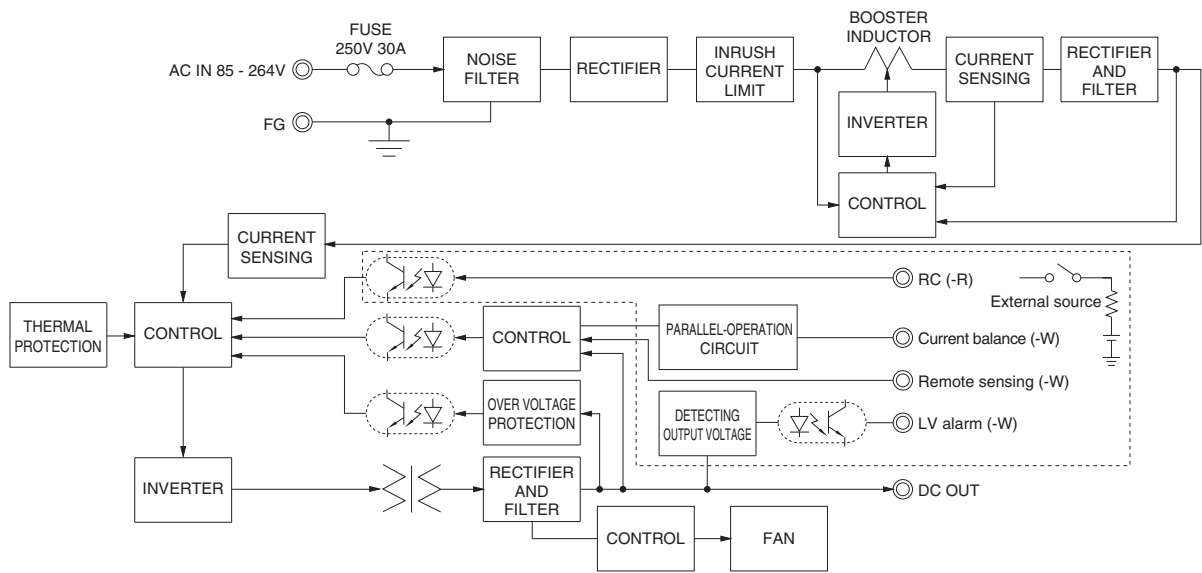

External view

The external size of -V option, -W option and -R option models is different from the standard model. See "6. Options and Others" in Instruction Manual for more details.

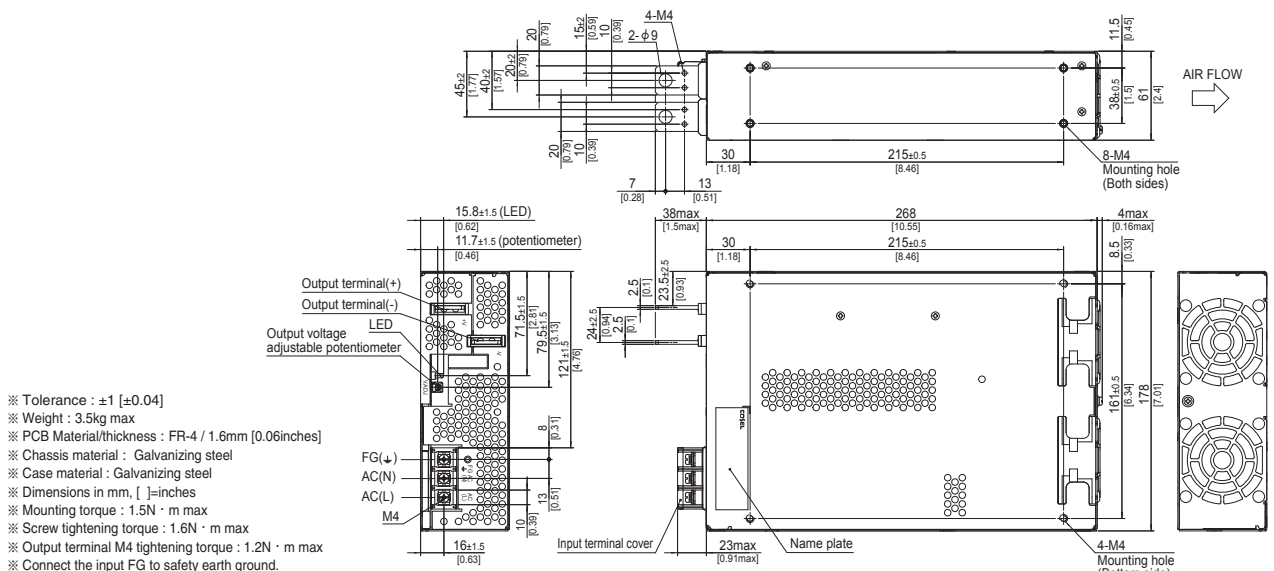

Assembling and Installation Method

PJA

■ Do not insert a screw more than 6mm from the outside of a power supply to keep enough insulation distance between the screw and internal components.

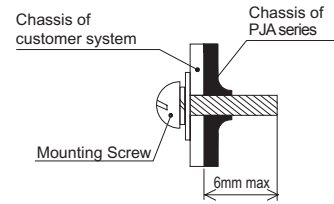

● PJA100F, PJA150F

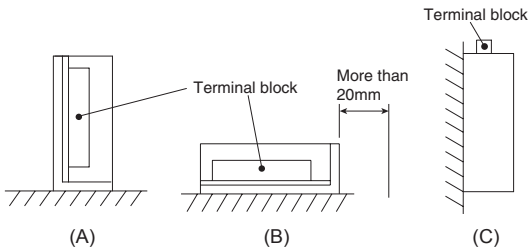

■ If you use two or more power supplies side by side, please keep a sufficient distance between them to allow enough air ventilation.
 ■ Ambient temperature around each power supply should not exceed the temperature range shown in “derating”.

● PJA300F

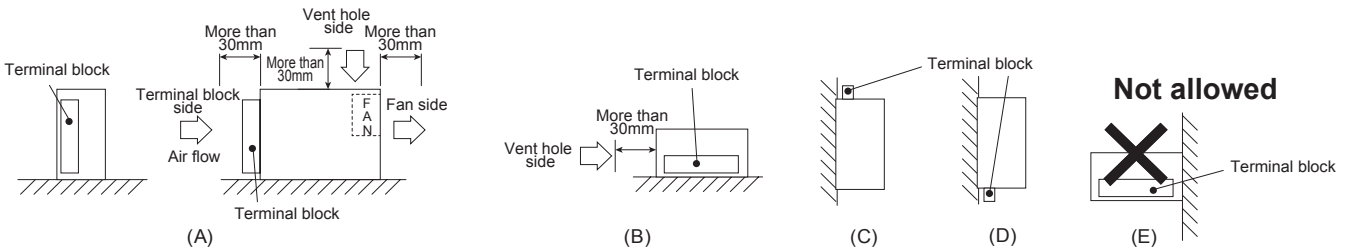

● PJA600F

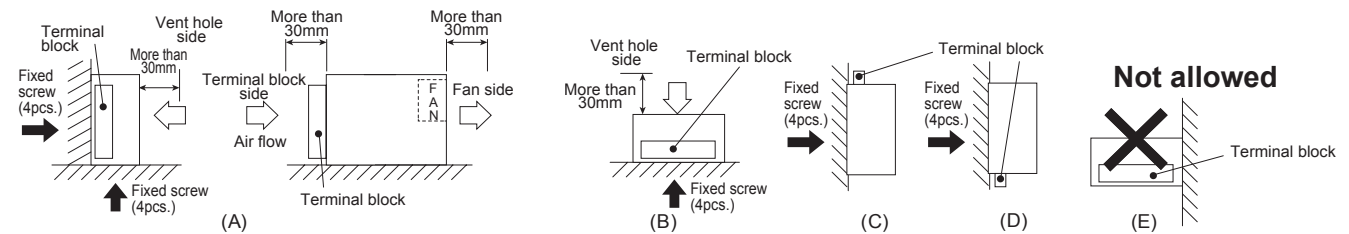

● PJA1000F, PJA1500F

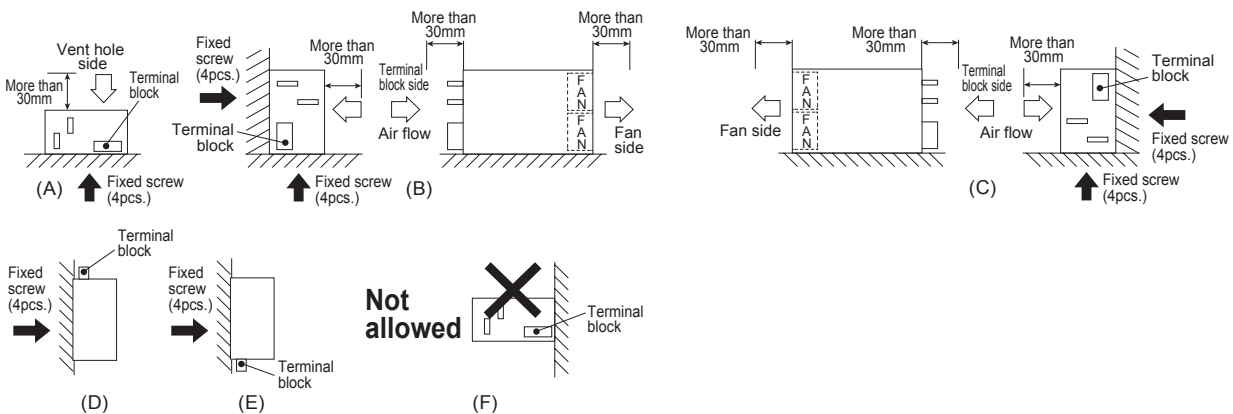

Assembling and Installation Method

- When mounting the power supply with screws, it is recommended that this be done as shown above . If other methods are used, be sure the weight of the power supply is taken into account.
- Avoid the not allowed installation method as it gives excessive stress to the mounting holes.
- Do not block air flow of the built-in fan (terminal block and ventilation hole).
- If the power supply is used in a dusty environment, use an airfilter. Make sure air flow is not blocked.
- If the built-in fan stops, thermal protection will work and the output will stop.
- The life expectancy (R(t)=90%) of the built-in fan varies depending on the operating condition.

PJA

Derating

Input voltage Derating Curve

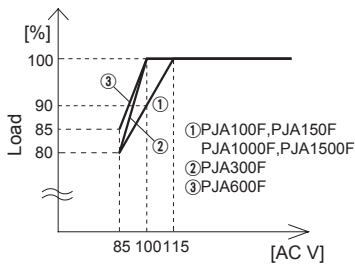

PJA100F/150F-12,15 Ambient temperature Derating Curve (Reference value)

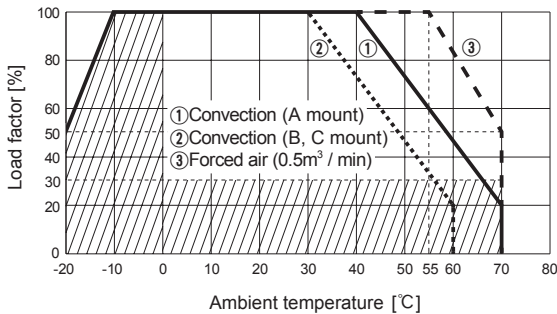

PJA100F/150F-24,36,48 Ambient temperature Derating Curve (Reference value)

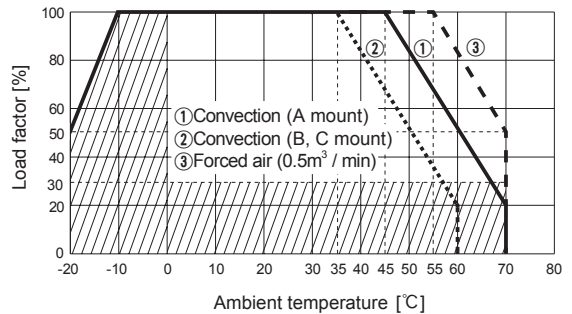

- In the hatched area, the specification of Ripple, Ripple Noise is different from other area.
- The ambient temperature should be measured 5 to 10 cm away from the power supply so that it won't be influenced by the heat from the power supply. Please consult us for more details.
- Make sure the temperature at point A and point B is less than the temperatures shown in Instruction Manual 3.

PJA300F Ambient temperature Derating Curve

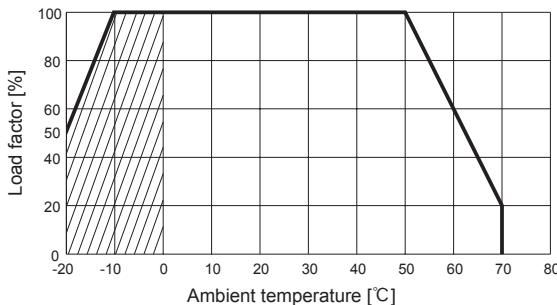

PJA600F/1000F/1500F Ambient temperature Derating Curve

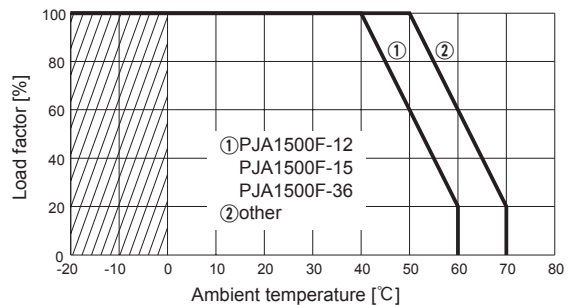

- The ambient temperature is defined as the temperature of the air (at the terminal block side) that the built-in cooling fan blows into the power supply. Please pay attention to the heat generated by the input and output wires. Please consult us for more details.

Instruction Manual

PJA

◆ It is necessary to read the “Instruction Manual” and “Before using our product” before you use our product.

Instruction Manual <https://www.cosel.co.jp/redirect/catalog/en/PJA/>
 Before using our product <https://en.cosel.co.jp/technical/caution/index.html>

PJA



NOTICE



Basic Characteristics Data

Model	Circuit method	Switching frequency [kHz]	Input current [A]	Rated input fuse	Inrush current protection circuit	PCB/Pattern			Series/Parallel operation availability	
						Material	Single sided	Double sided	Series operation	Parallel operation
PJA100F	Active filter	40 to 160	1.2 *1	250V 3.15A	Thermistor	FR-4		Yes	Yes	No
	Flyback converter	20 to 150 *2								
PJA150F	Active filter	40 to 160	1.7 *1	250V 4A	Thermistor	FR-4		Yes	Yes	No
	Flyback converter	20 to 150 *2								
PJA300F	Active filter	60	3.9 *3	250V 10A	Thermistor	FR-4		Yes	Yes	No
	Forward converter	140								
PJA600F	Active filter	60	7.5 *3	250V 16A	SCR	FR-4		Yes	Yes	*4
	Forward converter	220								
PJA1000F	Active filter	65	12.5 *1	250V 20A	TRIAC	FR-4		Yes	Yes	*4
	Forward converter	210								
PJA1500F	Active filter	65	18.0 *1	250V 30A	TRIAC	FR-4		Yes	Yes	*4
	Forward converter	210								

*1 The input current shown is at ACIN 100V and 90% load.

*2 The burst mode frequency varies according to the operating conditions. Consult us for more details.

*3 The input current shown is at ACIN 100V and 100% load.

*4 Parallel operation is possible with -W option, see “6.Option and Other” in Instruction Manual.



PLA-series

PLA

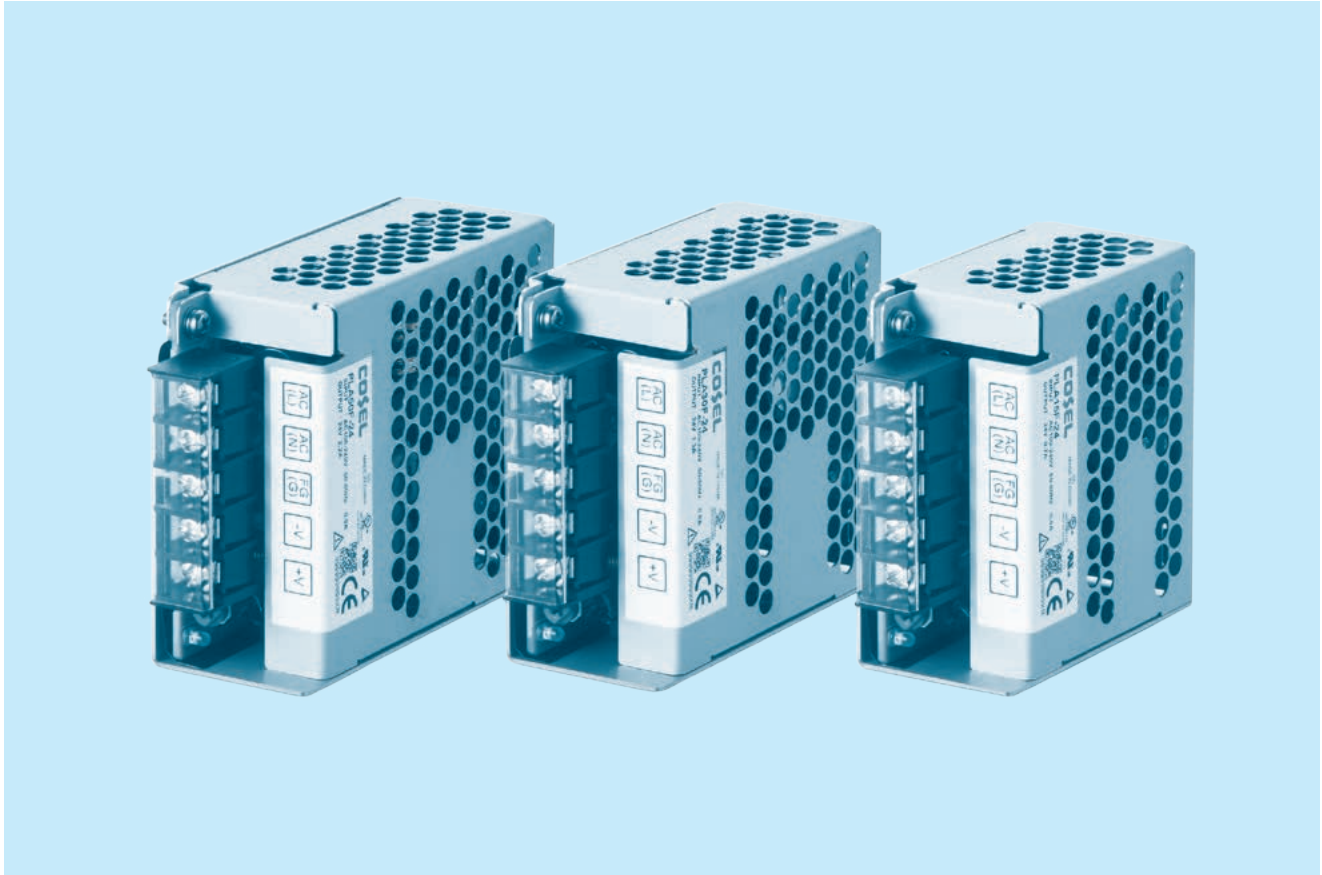

Feature

- Low Profile (1U size)
- Wide temperature range (-20°C to +70°C, Derating is required)
- Harmonic attenuator (Complies with IEC61000-3-2 class A)
- Universal input (AC85 - 264V, Derating is required)
- Low power consumption at no load
- Complies with SEMI F-47
- Many optional functions

Safety agency approvals

- UL60950-1, C-UL (CSA60950-1), EN62368-1
- UL508 (PLA15F-50F) approved
- Complies with DEN-AN

5-year warranty (See Instruction Manual)

CE marking

- Low Voltage Directive
- RoHS Directive

UKCA marking

- Electrical Equipment Safety Regulations
- RoHS Regulations

EMI

- Complies with FCC-B, CISPR22-B, EN55011-B, EN55022-B, VCCI-B

EMS Compliance : EN61204-3, EN61000-6-2

- EN61000-4-2
- EN61000-4-3
- EN61000-4-4
- EN61000-4-5
- EN61000-4-6
- EN61000-4-8
- EN61000-4-11

PLA15F

① **PL** ② **A** ③ **15** ④ **F** ⑤ **-□** ⑥ **-□**

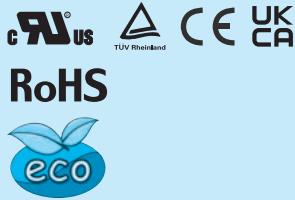

Example recommended EMI/EMC filter
NAC-04-472



High voltage pulse noise type : NAP series
Low leakage current type : NAM series
* A higher current rating EMI/EMC filter may be recommended in view of the other devices that could be connected in parallel with the power supply.

- ① Series name
- ② Single output
- ③ Output wattage
- ④ Universal input
- ⑤ Output voltage
- ⑥ Optional *7
- C : with Coating
- J : Connector interface
- T : Vertical terminal block
- N□ : with DIN rail

See 6.1 in Instruction Manual.

*Make sure necessary tests will be carried out on your end equipment with the power supply installed in accordance with any required EMC/EMI regulations.

SPECIFICATIONS

	MODEL	PLA15F-5	PLA15F-12	PLA15F-15	PLA15F-24	
INPUT	VOLTAGE[V]	AC85 - 264 1 φ (Output derating is required at AC85V - 115V. Refer to "Derating" and instruction manual 1.1, 3) *3				
	CURRENT[A]	ACIN 100V	0.4typ (Io=90%)			
		ACIN 115V	0.4typ (Io=100%)			
		ACIN 230V	0.25typ (Io=100%)			
	FREQUENCY[Hz]	50 / 60 (47 - 63)				
	EFFICIENCY[%]	ACIN 100V	72.5typ (Io=90%)	75.5typ (Io=90%)	77.0typ (Io=90%)	78.0typ (Io=90%)
		ACIN 115V	73.5typ (Io=100%)	77.0typ (Io=100%)	78.5typ (Io=100%)	79.0typ (Io=100%)
		ACIN 230V	75.5typ (Io=100%)	78.5typ (Io=100%)	79.5typ (Io=100%)	80.0typ (Io=100%)
INRUSH CURRENT[A]	ACIN 100V	16typ (Io=90%) Ta=25°C at cold start				
	ACIN 115V	16typ (Io=100%) Ta=25°C at cold start				
	ACIN 230V	32typ (Io=100%) Ta=25°C at cold start				
LEAKAGE CURRENT[ma]	0.30max (ACIN 115V / 240V, 60Hz, Io=100%, According to IEC62368-1 and DEN-AN)					
OUTPUT	VOLTAGE[V]	5	12	15	24	
	CURRENT[A]	3	1.3	1	0.7	
	WATTAGE[W]	ACIN 85-115V	Output derating is required at ACIN 115V or less (Refer to "Derating")			
		ACIN 115V-264V	15.0	15.6	15.0	16.8
	LINE REGULATION[mV] *4	20max	48max	60max	96max	
	LOAD REGULATION[mV] *4	40max	100max	120max	150max	
	RIPPLE[mVp-p] *1	0 to +50°C	80max	120max	120max	120max
		-10 to 0°C	140max	160max	160max	160max
		Io=0 to 35%	160max	240max	240max	280max
	RIPPLE NOISE[mVp-p] *1	0 to +50°C	120max	150max	150max	150max
		-10 to 0°C	160max	180max	180max	180max
		Io=0 to 35%	240max	300max	300max	320max
	TEMPERATURE REGULATION[mV]	0 to +50°C	50max	120max	150max	240max
		-10 to +50°C	60max	150max	180max	290max
	DRIFT[mV] *2	20max	48max	60max	96max	
START-UP TIME[ms]	200typ (ACIN 115V, Io=100%) *Start-up time is 700 ms typ for less than 1 minute of applying input again from turning off the input voltage.					
HOLD-UP TIME[ms]	20typ (ACIN 115V, Io=100%)					
OUTPUT VOLTAGE ADJUSTMENT RANGE[V]	4.50 to 5.50	10.80 to 13.20	13.50 to 16.50	21.60 to 26.40		
OUTPUT VOLTAGE SETTING[V]	5.00 to 5.15	12.00 to 12.48	15.00 to 15.60	24.00 to 24.96		
PROTECTION CIRCUIT AND OTHERS	OVERCURRENT PROTECTION	Works over 105% of rating and recovers automatically				
	OVERVOLTAGE PROTECTION[V]	5.75 to 7.00	13.80 to 16.80	17.25 to 21.00	27.60 to 33.60	
	OPERATING INDICATION	LED (Green)				
	REMOTE SENSING	Not provided				
REMOTE ON/OFF	Not provided					
ISOLATION	INPUT-OUTPUT	AC3,000V 1minute, Cutoff current = 10mA, DC500V 50MΩ min (At room temperature)				
	INPUT-FG	AC2,000V 1minute, Cutoff current = 10mA, DC500V 50MΩ min (At room temperature)				
	OUTPUT-FG	AC500V 1minute, Cutoff current = 25mA, DC500V 50MΩ min (At room temperature)				
ENVIRONMENT	OPERATING TEMP., HUMID. AND ALTITUDE *5	-20 to +70°C, 20 - 90%RH (Non condensing), 3,000m (10,000 feet) max				
	STORAGE TEMP., HUMID. AND ALTITUDE	-20 to +75°C, 20 - 90%RH (Non condensing), 9,000m (30,000 feet) max				
	VIBRATION	10 - 55Hz, 19.6m/s ² (2G), 3minutes period, 60minutes each along X, Y and Z axes				
	IMPACT	196.1m/s ² (20G), 11ms, once each X, Y and Z axes				
SAFETY AND NOISE REGULATIONS	AGENCY APPROVALS	UL60950-1, C-UL (CSA60950-1), EN62368-1, UL508 (Except option -J) Complies with DEN-AN				
	CONDUCTED NOISE	Complies with FCC-B, VCCI-B, CISPR22-B, EN55011-B, EN55022-B				
	HARMONIC ATTENUATOR *8	Complies with IEC61000-3-2 class A				

SPECIFICATIONS

OTHERS	CASE SIZE/WEIGHT	38×80×73mm [1.50×3.15×2.87 inches] (Excluding terminal block and screw) (W×H×D) / 250g max
	COOLING METHOD	Convection
WARRANTY	WARRANTY	*6 5 years (subject to the operating conditions)

- *1 This is the result of measurement of the testing board with capacitors of 22 μF and 0.1 μF placed at 150 mm from the output terminals by a 20 MHz oscilloscope or a ripple-noise meter equivalent to Keisoku-Giken RM103. See 1.6 of Instruction Manual for more details. When the load factor is 0 - 35%, the switching power loss is reduced by burst operation, which will cause ripple and ripple noise to go beyond the specifications.
- *2 Drift is the change in DC output for an eight hour period after a half-hour warm-up at 25°C.
- *3 As for DC input, consult us for advice.
- *4 Consult us about dynamic load and input response. Measure the output voltage by using the average mode of the tester to deal with the burst operation at 35% load or less.

- *5 Output power derating is required. Refer to "Derating".
- *6 See 4 in Instruction Manual for more details.
- *7 Consult us about safety agency approvals for the models with optional functions.
- *8 Consult us about other classes.
- * Do not use the power supply in overcurrent conditions or in unspecified input voltage ranges. Otherwise the internal components may be damaged.
- * Parallel operation is not possible with this mode.
- * Sound noise may be heard from the power supply when used for pulse load.

PLA

Features

- Compact design (Depth: 73mm 2.87inches)
- Low power consumption (1.0W typ AC240Vin, no load at standard model)
- UL508 approved (Except option -J), and complies with SEMI F47
- Various connection interface options (vertical terminal [-T], AMP connector [-J])

Block diagram

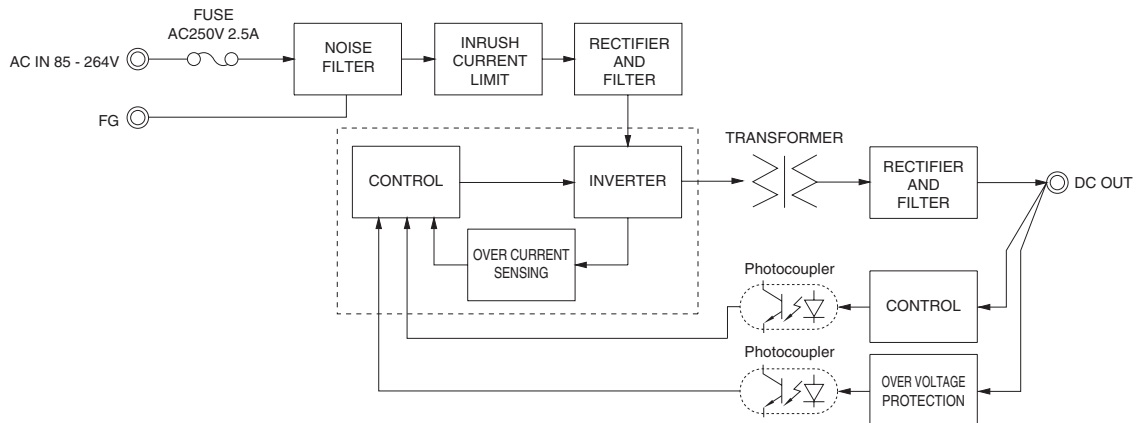

External view

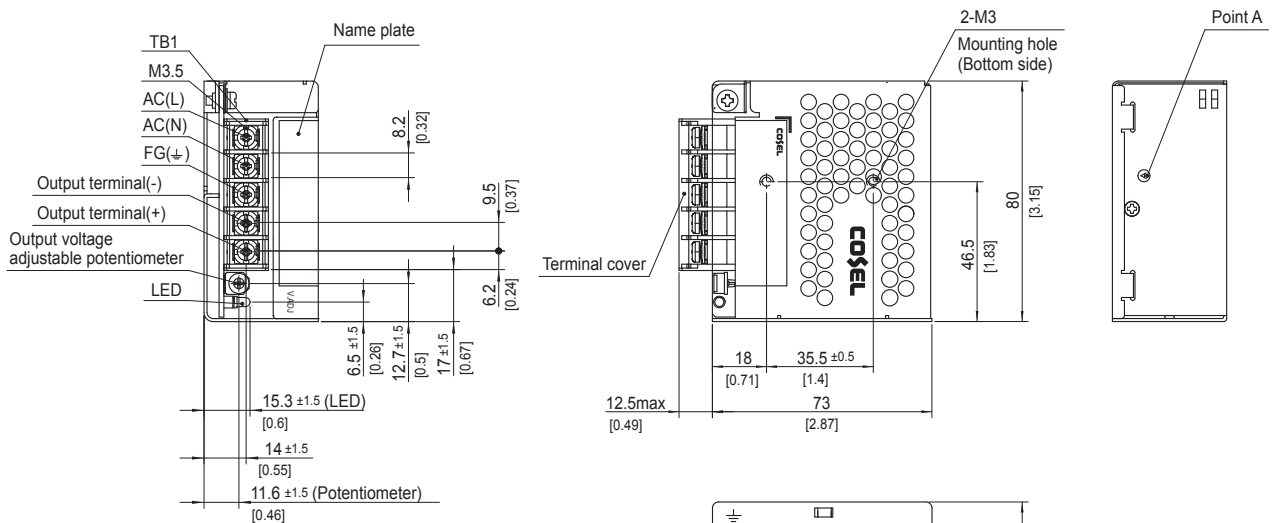

- ※ Tolerance : ±1 [±0.04]
- ※ Weight : 250g max
- ※ PCB Material/thickness : CEM-3 / 1.6mm [0.06inches]
- ※ Chassis material : Electric galvanizing steel board
- ※ Case material : Electric galvanizing steel board
- ※ Dimensions in mm, []=inches
- ※ Mounting torque : 0.6N · m max
- ※ Screw tightening torque : 1.0N · m max

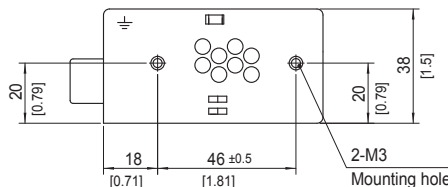

PLA30F

PL A 30 F -□ -□
 ① ② ③ ④ ⑤ ⑥

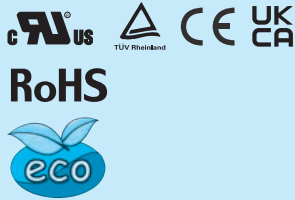

Example recommended EMI/EMC filter
NAC-04-472



High voltage pulse noise type : NAP series
 Low leakage current type : NAM series
 * A higher current rating EMI/EMC filter may be recommended in view of the other devices that could be connected in parallel with the power supply.

- ① Series name
- ② Single output
- ③ Output wattage
- ④ Universal input
- ⑤ Output voltage
- ⑥ Optional *7
- C : with Coating
- J : Connector interface
- T : Vertical terminal block
- N□ : with DIN rail

See 6.1 in Instruction Manual.

*Make sure necessary tests will be carried out on your end equipment with the power supply installed in accordance with any required EMC/EMI regulations.

SPECIFICATIONS

	MODEL	PLA30F-5	PLA30F-12	PLA30F-15	PLA30F-24	
INPUT	VOLTAGE[V]	AC85 - 264 1 φ (Output derating is required at AC85V - 115V. Refer to "Derating" and instruction manual 1.1, 3) *3				
	CURRENT[A]	ACIN 100V	0.7typ (Io=90%)			
		ACIN 115V	0.7typ (Io=100%)			
		ACIN 230V	0.4typ (Io=100%)			
	FREQUENCY[Hz]	50 / 60 (47 - 63)				
	EFFICIENCY[%]	ACIN 100V	73.0typ (Io=90%)	80.0typ (Io=90%)	81.0typ (Io=90%)	82.5typ (Io=90%)
		ACIN 115V	74.0typ (Io=100%)	80.5typ (Io=100%)	81.5typ (Io=100%)	83.0typ (Io=100%)
ACIN 230V		77.0typ (Io=100%)	81.0typ (Io=100%)	82.0typ (Io=100%)	83.5typ (Io=100%)	
INRUSH CURRENT[A]	ACIN 100V	16typ (Io=90%) Ta=25°C at cold start				
	ACIN 115V	16typ (Io=100%) Ta=25°C at cold start				
	ACIN 230V	32typ (Io=100%) Ta=25°C at cold start				
LEAKAGE CURRENT[ma]	0.65max (ACIN 115V / 240V, 60Hz, Io=100%, According to IEC62368-1 and DEN-AN)					
OUTPUT	VOLTAGE[V]	5	12	15	24	
	CURRENT[A]	6	2.5	2	1.3	
	WATTAGE[W]	ACIN 85-115V	Output derating is required at ACIN 115V or less (Refer to "Derating")			
		ACIN 115V-264V	30.0	30.0	30.0	31.2
	LINE REGULATION[mV] *4	20max	48max	60max	96max	
	LOAD REGULATION[mV] *4	40max	100max	120max	150max	
	RIPPLE[mVp-p] *1	0 to +50°C	80max	120max	120max	120max
		-10 to 0°C	140max	160max	160max	160max
	RIPPLE NOISE[mVp-p] *1	0 to +50°C	120max	150max	150max	150max
		-10 to 0°C	160max	180max	180max	180max
	TEMPERATURE REGULATION[mV]	0 to +50°C	50max	120max	150max	240max
		-10 to +50°C	60max	150max	180max	290max
	DRIFT[mV] *2	20max	48max	60max	96max	
	START-UP TIME[ms]	150typ (ACIN 115V, Io=100%)				
HOLD-UP TIME[ms]	20typ (ACIN 115V, Io=100%)					
OUTPUT VOLTAGE ADJUSTMENT RANGE[V]	4.50 to 5.50	10.80 to 13.20	13.50 to 16.50	21.60 to 26.40		
OUTPUT VOLTAGE SETTING[V]	5.00 to 5.15	12.00 to 12.48	15.00 to 15.60	24.00 to 24.96		
PROTECTION CIRCUIT AND OTHERS	OVERCURRENT PROTECTION	Works over 105% of rating and recovers automatically				
	OVERVOLTAGE PROTECTION[V]	5.75 to 7.00	13.80 to 16.80	17.25 to 21.00	27.60 to 33.60	
	OPERATING INDICATION	LED (Green)				
	REMOTE SENSING	Not provided				
ISOLATION	REMOTE ON/OFF	Not provided				
	INPUT-OUTPUT	AC3,000V 1minute, Cutoff current = 10mA, DC500V 50MΩ min (At room temperature)				
	INPUT-FG	AC2,000V 1minute, Cutoff current = 10mA, DC500V 50MΩ min (At room temperature)				
ENVIRONMENT	OUTPUT-FG	AC500V 1minute, Cutoff current = 25mA, DC500V 50MΩ min (At room temperature)				
	OPERATING TEMP., HUMID. AND ALTITUDE *5	-20 to +70°C, 20 - 90%RH (Non condensing), 3,000m (10,000 feet) max				
	STORAGE TEMP., HUMID. AND ALTITUDE	-20 to +75°C, 20 - 90%RH (Non condensing), 9,000m (30,000 feet) max				
	VIBRATION	10 - 55Hz, 19.6m/s ² (2G), 3minutes period, 60minutes each along X, Y and Z axes				
SAFETY AND NOISE REGULATIONS	IMPACT	196.1m/s ² (20G), 11ms, once each X, Y and Z axes				
	AGENCY APPROVALS	UL60950-1, C-UL (CSA60950-1), EN62368-1, UL508 (Except option -J) Complies with DEN-AN				
	CONDUCTED NOISE	Complies with FCC-B, VCCI-B, CISPR22-B, EN55011-B, EN55022-B				
	HARMONIC ATTENUATOR *8	Complies with IEC61000-3-2 class A				

SPECIFICATIONS

OTHERS	CASE SIZE/WEIGHT	38×80×88mm [1.50×3.15×3.46 inches] (Excluding terminal block and screw) (W×H×D) / 330g max
	COOLING METHOD	Convection
WARRANTY	WARRANTY	*6 5 years (subject to the operating conditions)

- *1 This is the result of measurement of the testing board with capacitors of 22 μF and 0.1 μF placed at 150 mm from the output terminals by a 20 MHz oscilloscope or a ripple-noise meter equivalent to Keisoku-Giken RM103.
See 1.6 of Instruction Manual for more details.
- *2 Drift is the change in DC output for an eight hour period after a half-hour warm-up at 25°C.
- *3 As for DC input, consult us for advice.
- *4 Consult us about dynamic load and input response.
- *5 Output power derating is required. Refer to "Derating".
- *6 See 4 in Instruction Manual for more details.
- *7 Consult us about safety agency approvals for the models with optional functions.
- *8 Consult us about other classes.
- * Do not use the power supply in overcurrent conditions or in unspecified input voltage ranges. Otherwise the internal components may be damaged.
- * Parallel operation is not possible with this mode.
- * Sound noise may be heard from the power supply when used for pulse load.

PLA

Features

- Compact design (Depth: 88mm 3.46inches)
- UL508 approved (Except option -J), and complies with SEMI F47
- Various connection interface options (vertical terminal [-T], AMP connector [-J])

Block diagram

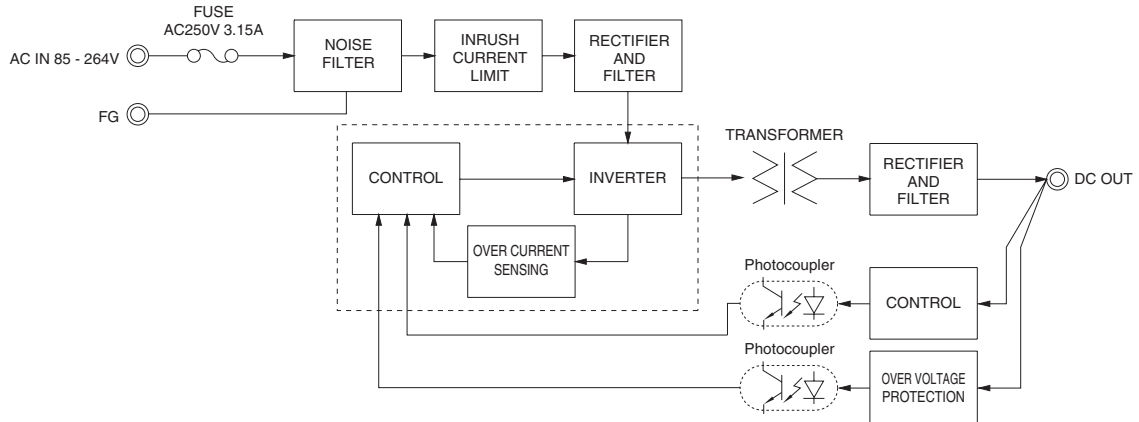

External view

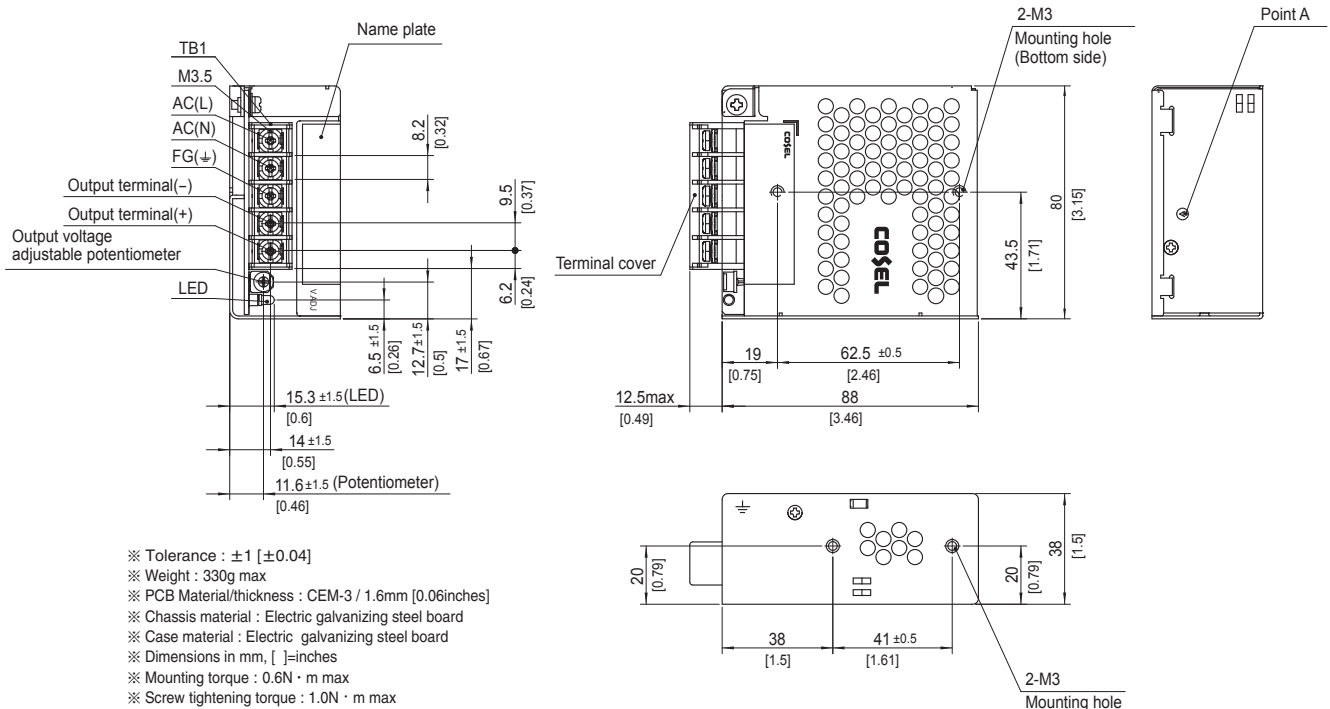

PLA50F

① **PL** ② **A** ③ **50** ④ **F** ⑤ **-□** ⑥ **-□**



Example recommended EMI/EMC filter
NAC-04-472



High voltage pulse noise type : NAP series
Low leakage current type : NAM series
* A higher current rating EMI/EMC filter may be recommended in view of the other devices that could be connected in parallel with the power supply.

- ① Series name
- ② Single output
- ③ Output wattage
- ④ Universal input
- ⑤ Output voltage
- ⑥ Optional *7
C : with Coating
J : Connector interface
T : Vertical terminal block
□ : with DIN rail

See 6.1 in Instruction Manual.

*Make sure necessary tests will be carried out on your end equipment with the power supply installed in accordance with any required EMC/EMI regulations.

SPECIFICATIONS

	MODEL	PLA50F-5	PLA50F-12	PLA50F-15	PLA50F-24	
INPUT	VOLTAGE[V]	AC85 - 264 1 φ (Output derating is required at AC85V - 115V. Refer to "Derating" and instruction manual 1.1, 3) *3				
	CURRENT[A]	ACIN 100V	0.6typ (Io=90%)	0.7typ (Io=90%)		
		ACIN 115V	0.6typ (Io=100%)	0.7typ (Io=100%)		
		ACIN 230V	0.3typ (Io=100%)	0.4typ (Io=100%)		
	FREQUENCY[Hz]	50 / 60 (47 - 63)				
	EFFICIENCY[%]	ACIN 100V	74.5typ (Io=90%)	80.0typ (Io=90%)	80.0typ (Io=90%)	81.5typ (Io=90%)
		ACIN 115V	75.0typ (Io=100%)	80.5typ (Io=100%)	80.5typ (Io=100%)	82.0typ (Io=100%)
		ACIN 230V	76.5typ (Io=100%)	82.0typ (Io=100%)	82.0typ (Io=100%)	84.0typ (Io=100%)
	POWER FACTOR	ACIN 100V	0.97typ (Io=90%)	0.98typ (Io=90%)		
		ACIN 115V	0.97typ (Io=100%)	0.98typ (Io=100%)		
ACIN 230V		0.85typ (Io=100%)	0.87typ (Io=100%)			
INRUSH CURRENT[A]	ACIN 100V	16typ (Io=90%) Ta=25°C at cold start				
	ACIN 115V	16typ (Io=100%) Ta=25°C at cold start				
	ACIN 230V	32typ (Io=100%) Ta=25°C at cold start				
LEAKAGE CURRENT[ma]	0.75max (ACIN 115V / 240V, 60Hz, Io=100%, According to IEC62368-1 and DEN-AN)					
OUTPUT	VOLTAGE[V]	5	12	15	24	
	CURRENT[A]	8	4.3	3.5	2.2	
	WATTAGE[W]	ACIN 85-115V	Output derating is required at ACIN 115V or less (Refer to "Derating")			
		ACIN 115V-264V	40.0	51.6	52.5	52.8
	LINE REGULATION[mV] *4	20max	48max	60max	96max	
	LOAD REGULATION[mV] *4	40max	100max	120max	150max	
	RIPPLE[mVp-p] *1	0 to +45°C	80max	120max	120max	120max
		-10 to 0°C	140max	160max	160max	160max
	RIPPLE NOISE[mVp-p] *1	0 to +45°C	120max	150max	150max	150max
		-10 to 0°C	160max	180max	180max	180max
	TEMPERATURE REGULATION[mV]	0 to +45°C	50max	120max	150max	240max
		-10 to +45°C	60max	150max	180max	290max
	DRIFT[mV] *2	20max	48max	60max	96max	
	START-UP TIME[ms]	350typ (ACIN 115V, Io=100%)				
	HOLD-UP TIME[ms]	20typ (ACIN 115V, Io=100%)				
	OUTPUT VOLTAGE ADJUSTMENT RANGE[V]	4.50 to 5.50	10.80 to 13.20	13.50 to 16.50	21.60 to 26.40	
	OUTPUT VOLTAGE SETTING[V]	5.00 to 5.15	12.00 to 12.48	15.00 to 15.60	24.00 to 24.96	
PROTECTION CIRCUIT AND OTHERS	OVERCURRENT PROTECTION	Works over 105% of rating and recovers automatically				
	OVERVOLTAGE PROTECTION[V]	5.75 to 7.00	13.80 to 16.80	17.25 to 21.00	27.60 to 33.60	
	OPERATING INDICATION	LED (Green)				
	REMOTE SENSING	Not provided				
ISOLATION	REMOTE ON/OFF	Not provided				
	INPUT-OUTPUT	AC3,000V 1minute, Cutoff current = 10mA, DC500V 50MΩ min (At room temperature)				
	INPUT-FG	AC2,000V 1minute, Cutoff current = 10mA, DC500V 50MΩ min (At room temperature)				
ENVIRONMENT	OUTPUT-FG	AC500V 1minute, Cutoff current = 25mA, DC500V 50MΩ min (At room temperature)				
	OPERATING TEMP., HUMID. AND ALTITUDE *5	-20 to +70°C, 20 - 90%RH (Non condensing), 3,000m (10,000 feet) max				
	STORAGE TEMP., HUMID. AND ALTITUDE	-20 to +75°C, 20 - 90%RH (Non condensing), 9,000m (30,000 feet) max				
	VIBRATION	10 - 55Hz, 19.6m/s ² (2G), 3minutes period, 60minutes each along X, Y and Z axes				
SAFETY AND NOISE REGULATIONS	IMPACT	196.1m/s ² (20G), 11ms, once each X, Y and Z axes				
	AGENCY APPROVALS	UL60950-1, C-UL (CSA60950-1), EN62368-1, UL508 (Except option -J) Complies with DEN-AN				
	CONDUCTED NOISE	Complies with FCC-B, VCCI-B, CISPR22-B, EN55011-B, EN55022-B				
	HARMONIC ATTENUATOR *8	Complies with IEC61000-3-2 class A				

SPECIFICATIONS

OTHERS	CASE SIZE/WEIGHT	38 × 80 × 99mm [1.50 × 3.15 × 3.90 inches] (Excluding terminal block and screw) (W × H × D) / 400g max
	COOLING METHOD	Convection
WARRANTY	WARRANTY	*6 5 years (subject to the operating conditions)

- *1 This is the result of measurement of the testing board with capacitors of 22 μF and 0.1 μF placed at 150 mm from the output terminals by a 20 MHz oscilloscope or a ripple-noise meter equivalent to Keisoku-Giken RM103.
See 1.6 of Instruction Manual for more details.
- *2 Drift is the change in DC output for an eight hour period after a half-hour warm-up at 25°C.
- *3 As for DC input, consult us for advice.
- *4 Consult us about dynamic load and input response.
- *5 Output power derating is required. Refer to "Derating".
- *6 See 4 in Instruction Manual for more details.
- *7 Consult us about safety agency approvals for the models with optional functions.
- *8 Consult us about other classes.
- * Do not use the power supply in overcurrent conditions or in unspecified input voltage ranges. Otherwise the internal components may be damaged.
- * Parallel operation is not possible with this mode.
- * Sound noise may be heard from the power supply when used for pulse load.

PLA

Features

- Compact design (Depth: 99mm 3.90inches)
- UL508 approved (Except option -J), and complies with SEMI F47
- Various connection interface options (vertical terminal [-T], AMP connector [-J])

Block diagram

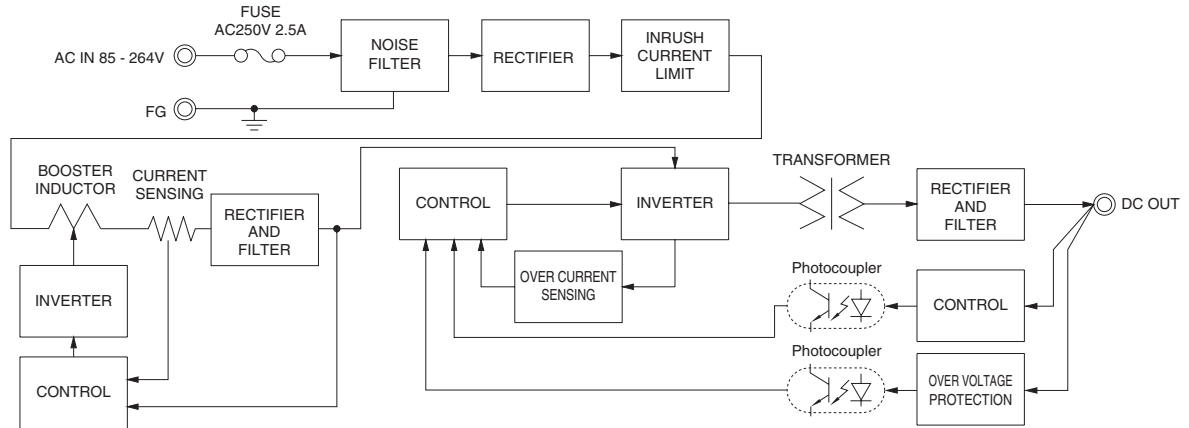

External view

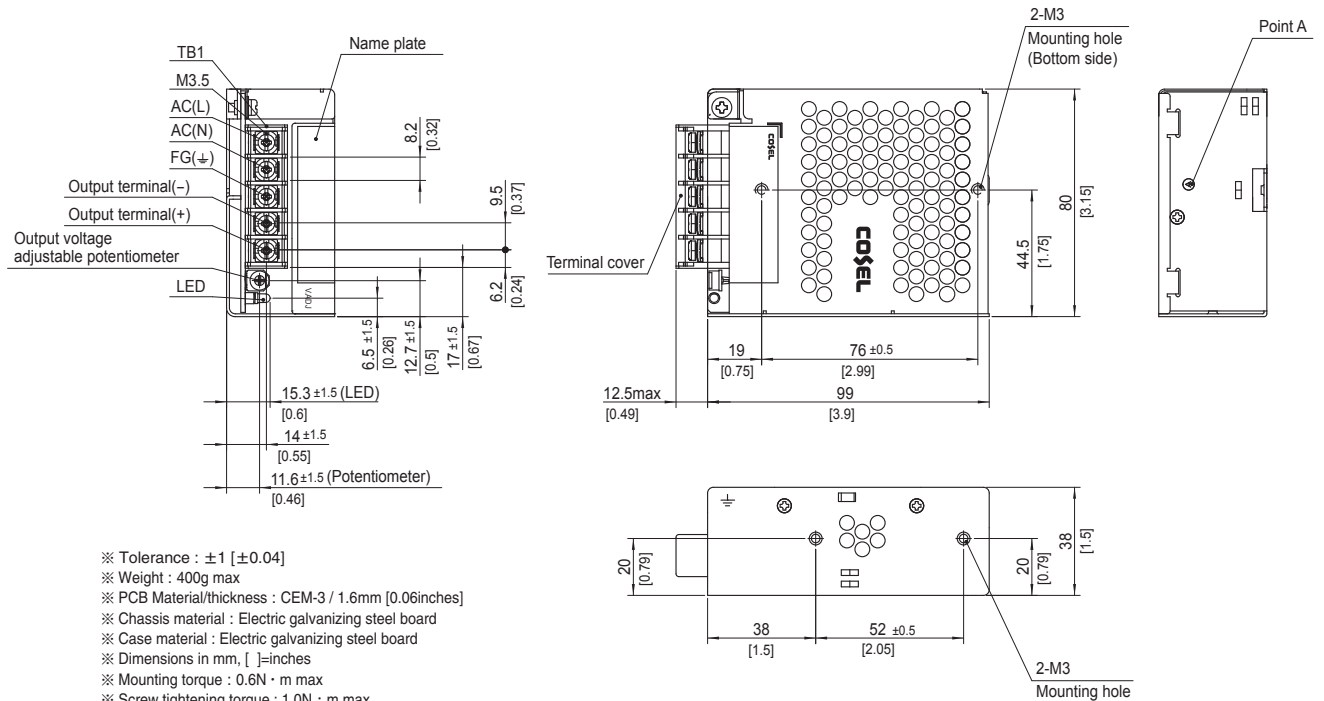

Assembling and Installation Method

Installation method

Do not insert a screw more than 6mm from the outside of a power supply to keep enough insulation distance between the screw and internal components.

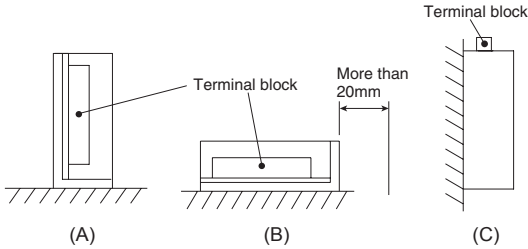
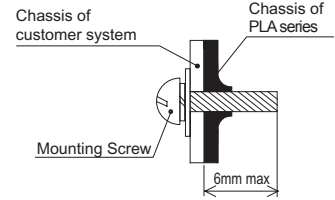

If you use two or more power supplies side by side, please keep a sufficient distance between them to allow enough air ventilation.
 Ambient temperature around each power supply should not exceed the temperature range shown in "Derating".

Derating

Input voltage Derating Curve

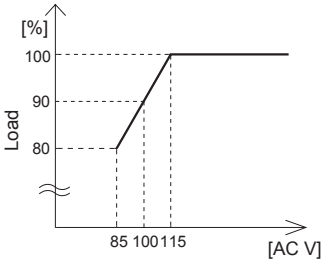

PLA15F Ambient temperature Derating Curve (Reference value)

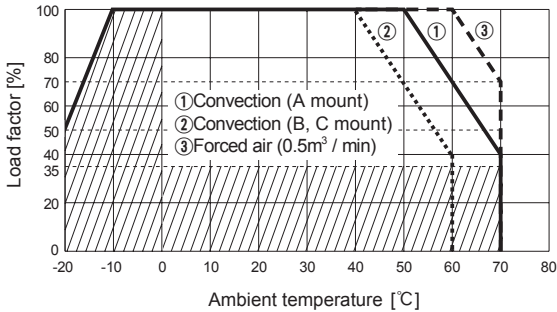

PLA30F Ambient temperature Derating Curve (Reference value)

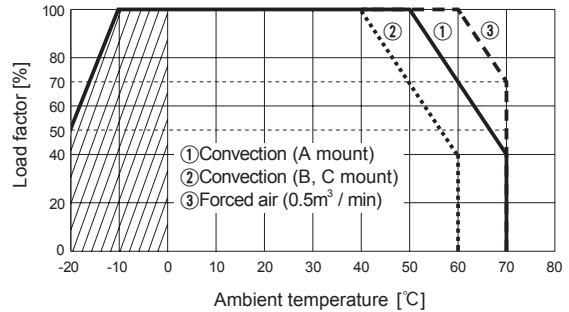

PLA50F-5 Ambient temperature Derating Curve (Reference value)

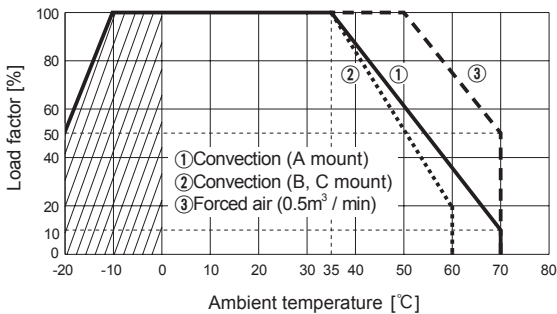

PLA50F-12,-15,-24 Ambient temperature Derating Curve (Reference value)

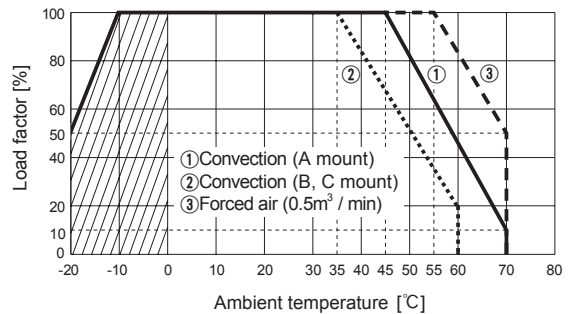

Derating

- In the hatched area, the specification of Ripple, Ripple Noise is different from other area.
- The ambient temperature should be measured 5 to 10 cm away from the power supply so that it won't be influenced by the heat from the power supply. Please consult us for more details.
- The derating curve by the ambient temperature shows the operating temperature range for a 3-year continuous use. It shows not the limit of use but the temperature of an expected life. Consult us for the operation limit temperature.
- Make sure the temperature at point A and point B is less than the temperatures shown in Instruction Manual 3.

Instruction Manual

- ◆ It is necessary to read the "Instruction Manual" and "Before using our product" before you use our product.

Instruction Manual <https://www.cosel.co.jp/redirect/catalog/en/PLA/>
 Before using our product <https://en.cosel.co.jp/technical/caution/index.html>

PLA



NOTICE



Basic Characteristics Data

Model	Circuit method	Switching frequency [kHz]	Input current [A]	Rated input fuse	Inrush current protection circuit	PCB/Pattern			Series/Parallel operation availability	
						Material	Single sided	Double sided	Series operation	Parallel operation
PLA15F	Flyback converter	100	0.4 *	250V 2.5A	Thermistor	CEM-3	Yes		Yes	No
PLA30F	Flyback converter	130	0.7 *	250V 3.15A	Thermistor	CEM-3	Yes		Yes	No
PLA50F	Active filter	60 to 440	0.7 *	250V 2.5A	Thermistor	CEM-3	Yes		Yes	No
	Flyback converter	130								

* The input current shown is at ACIN 100V and 100% load.

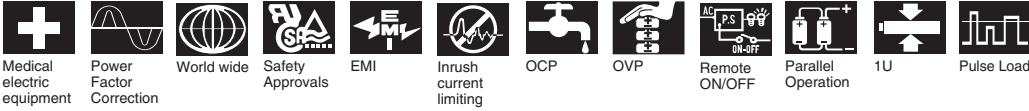

AEA-series

AEA

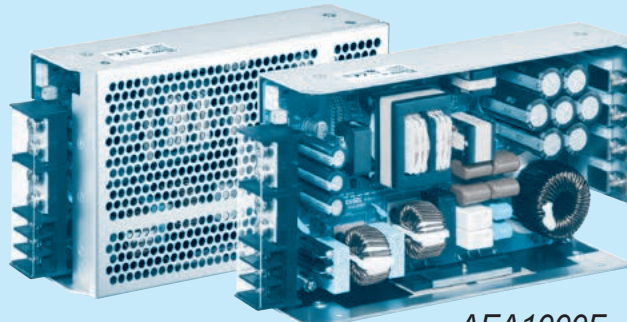

AEA1000F

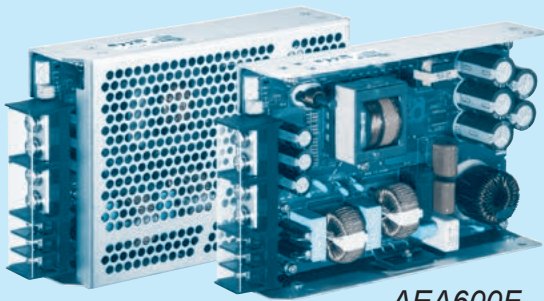

AEA600F

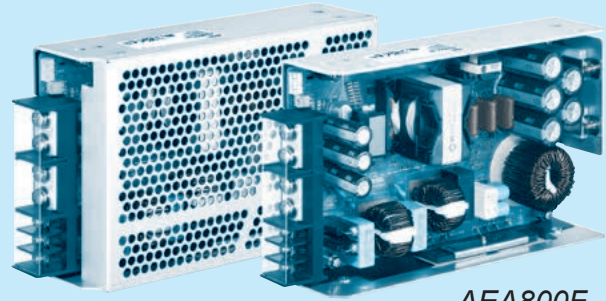

AEA800F

Feature

- High power & peak power
- High efficiency
- Low profile (41mm, 1.61 inch = meet to 1U height)
- For medical electric equipment (ANSI/AAMI ES60601, EN60601-1 3rd, IEC60601-1-2 4th Ed.)
- Suitable for BF application (Output-FG : 1MOPP, Input-Output : 2MOPP)
- OVC III (according to EN62477-1)
- Complies with SEMI F47 (Refer to Instruction Manual)
- UL508 (Optional)

Safety agency approval

- UL62368-1, ANSI/AAMI ES60601-1
- C-UL (CAN/CSA62368-1, CAN/CSA60601-1)
- EN62368-1, EN60601-1 3rd
- Complies with IEC60601-1-2 4th Ed. , IEC60335-1(AEA600F)
- EN62477-1 (OVC III)
- UL508 (Optional)

5-year warranty (Refer to Instruction Manual)

CE marking

- Low Voltage Directive
- RoHS Directive

UKCA marking

- Electrical Equipment Safety Regulations
- RoHS Regulations

EMI

- Complies with FCC-B, CISPR11-B, CISPR32-B, EN55011-B, EN55032-B, VCCI-B

EMS Compliance : EN61204-3, EN61000-6-2 IEC60601-1-2(2014), EN60601-1-2(2015)

- EN61000-4-2
- EN61000-4-3
- EN61000-4-4
- EN61000-4-5
- EN61000-4-6
- EN61000-4-8
- EN61000-4-11

AEA600F

AE A 600 F -□□ -□
 ① ② ③ ④ ⑤ ⑥

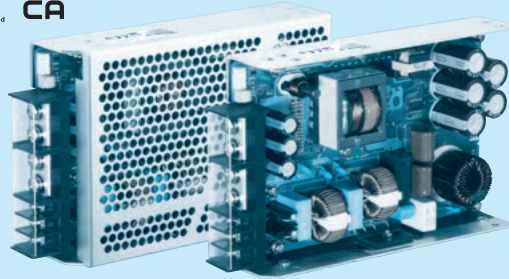

Example recommended EMI/EMC filter
EAC-20-472



High voltage pulse noise type : EAP series
 Low leakage current type : EAM series
 *Use of an EMI/EMC filter is recommended when a power supply is connected with several devices so that additional filtering is necessary.
 *Make sure that your final application will meet the required EMC standard by measuring the EMI level of the power supply used together with an EMI/EMC filter.

- ① Series name
 - ② Single output
 - ③ Output wattage
 - ④ Universal input
 - ⑤ Output voltage
 - ⑥ Optional *1
 - C : with Coating
 - N : with cover
 - T : Vertical terminal block
 - J : Connector type
 - R3: with Subfeatures (5V1A AUX, 12V1A AUX Remote ON/OFF, Alarm)
 - T5 : UL508 (Except 32V)
 - P5 : shutdown type overcurrent protection
- For option details, refer to instruction manual 6.1.

Please refer to derating curve, because the rated load current depends on cooling method that is convection cooling or forced air.

*Make sure necessary tests will be carried out on your end equipment with the power supply installed in accordance with any required EMC/EMI regulations.

MODEL	AEA600F-24	AEA600F-32	AEA600F-36	AEA600F-48
MAX OUTPUT WATTAGE[W]	600	601	601.2	600
DC OUTPUT (forced air)	ACIN 100V	24V 20.0 (Peak 42.0) A	32V 15.0 (Peak 31.5) A	36V 13.4 (Peak 28.0) A
	ACIN 230V	24V 25.0 (Peak 52.5) A	32V 18.8 (Peak 39.4) A	36V 16.7 (Peak 35.0) A

SPECIFICATIONS

	MODEL	AEA600F-24	AEA600F-32	AEA600F-36	AEA600F-48	
INPUT	VOLTAGE[V]	AC85 - 264 1 φ (Output derating is required at AC85V - 170V. See "Derating")				
	CURRENT[A]	ACIN 100V	5.7typ (Io=20A)	5.7typ (Io=15.0A)	5.7typ (Io=13.4A)	5.7typ (Io=10A)
		ACIN 230V	2.9typ (Io=25A)	2.9typ (Io=18.8A)	2.9typ (Io=16.7A)	2.9typ (Io=12.5A)
	FREQUENCY[Hz]	50/60 (45 - 66)				
	EFFICIENCY[%]	ACIN 100V	92.0%typ (Io=20A)	92.0typ (Io=15.0A)	92.0%typ (Io=13.4A)	92.0%typ (Io=10A)
		ACIN 230V	94.5%typ (Io=25A)	95.0typ (Io=18.8A)	95.0%typ (Io=16.7A)	95.0%typ (Io=12.5A)
	POWER FACTOR	ACIN 100V	0.98typ (Io=20A)	0.98typ (Io=15.0A)	0.98typ (Io=13.4A)	0.98typ (Io=10A)
		ACIN 230V	0.95typ (Io=25A)	0.95typ (Io=18.8A)	0.95typ (Io=16.7A)	0.95typ (Io=12.5A)
INRUSH CURRENT[A] *2	ACIN 100V	20/40typ (Io=20A)	20/40typ (Io=15.0A)	20/40typ (Io=13.4A)	20/40typ (Io=10A)	
	ACIN 230V	40/40typ (Io=25A)	40/40typ (Io=18.8A)	40/40typ (Io=16.7A)	40/40typ (Io=12.5A)	
LEAKAGE CURRENT[mA]	0.3max (ACIN 240V 60Hz, Io=100%, According to IEC60601-1)					
OUTPUT	VOLTAGE[V]	24	32	36	48	
	CURRENT[A]	ACIN 100V	14.0 (Peak 42.0) convection	10.5 (Peak 31.5) convection	9.4 (Peak 28.0) convection	7.0 (Peak 21.0) convection
			20.0 (Peak 42.0) forced air	15.0 (Peak 31.5) forced air	13.4 (Peak 28.0) forced air	10.0 (Peak 21.0) forced air
		ACIN 230V	17.5 (Peak 52.5) convection	13.2 (Peak 39.4) convection	11.7 (Peak 35.0) convection	8.8 (Peak 26.3) convection
			25.0 (Peak 52.5) forced air	18.8 (Peak 39.4) forced air	16.7 (Peak 35.0) forced air	12.5 (Peak 26.3) forced air
	LINE REGULATION[mV]	96max	144max	144max	192max	
	LOAD REGULATION[mV]	150max	240max	240max	300max	
	RIPPLE[mVp-p] *3	0 to +50°C	120max	200max	200max	200max
		-20 to 0°C	200max	300max	300max	350max
	RIPPLE NOISE[mVp-p] *3	0 to +50°C	150max	270max	230max	250max
		-20 to 0°C	230max	350max	350max	500max
	TEMPERATURE REGULATION[mV]	0 to +50°C	240max	360max	360max	480max
	DRIFT[mV] *4	96max	144max	144max	192max	
	START-UP[ms]	750typ				
HOLD-UP[ms]	20typ (ACIN 230V, Io=100%)					
OUTPUT VOLTAGE ADJUSTMENT RANGE[V]	21.6 to 26.4	28.8 to 35.2	32.4 to 39.6	43.2 to 52.8		
OUTPUT VOLTAGE SETTING[V]	23.5 to 24.5	31.0 to 33.0	35.0 to 37.0	47.0 to 49.0		
PROTECTION CIRCUIT AND OTHERS	OVERCURRENT PROTECTION	Works over 101% of peak current and recovers automatically *5				
	OVERVOLTAGE PROTECTION[V]	30 to 33.6	43.0 to 48.4	45 to 50.4	60 to 69.6	
	ALARM	Optional (Input voltage alarm : PR, Output voltage alarm : PG)				
	REMOTE ON/OFF	Optional				
	AUX1	Optional (12V1A forced air)				
AUX2	Optional (5V1A forced air)					
ISOLATION	INPUT-OUTPUT · PR · PG · RC · AUX *6	AC4,000V 1minute, Cutoff current = 10mA, DC500V 50MΩ min (At Room Temperature) 2MOPP				
	INPUT-FG	AC2,000V 1minute, Cutoff current = 10mA, DC500V 50MΩ min (At Room Temperature) 1MOPP				
	OUTPUT · PR · PG · RC · AUX-FG *6	AC1,500V 1minute, Cutoff current = 10mA, DC500V 50MΩ min (At Room Temperature) 1MOPP				
	OUTPUT · AUX1-PR · PG · RC · AUX2 *6	AC100V 1minute, Cutoff current = 25mA, DC100V 10MΩ min (At Room Temperature)				
ENVIRONMENT	OPERATING TEMP., HUMID. AND ALTITUDE	-20 to +70°C, 20 - 90%RH (Non condensing), 5,000m (16,500feet) max				
	STORAGE TEMP., HUMID. AND ALTITUDE	-20 to +75°C, 20 - 90%RH (Non condensing), 9,000m (30,000feet) max				
	VIBRATION	10 - 55Hz, 19.6m/s ² (2G), 3minutes period, 60minutes each along X, Y and Z axis				
IMPACT	196.1m/s ² (20G), 11ms, once each X, Y and Z axis					
SAFETY AND NOISE REGULATIONS	AGENCY APPROVALS	UL62368-1, AANSI/AAMI ES 60601-1, C-UL (equivalent to CAN/CSA-C22.2 No.62368-1, CAN/CSA-C22.2 No.60601-1) EN62368-1, EN60601-1 3rd, EN62477-1 (OVCI), UL508 (Optional. Except 32V), Complies with IEC60601-1-2 4th Ed., IEC60335-1(AEA600F)				
	CONDUCTED NOISE	Complies with FCC Part15 classB, VCCI-B, CISPR32-B, EN55011-B, EN55032-B				
	HARMONIC ATTENUATOR *7	Complies with IEC61000-3-2 (Class A)				
OTHERS	CASE SIZE/WEIGHT	41x127x186mm [1.61x5x7.32 inches] (WxHxD) (without terminal block) / 1.0kg max				
	COOLING METHOD	Convection/Forced air				

*1 The listed options may affect the published standard specifications. Please contact us for detailed product specification.

*2 The current of input surge to a built-in EMI/EMS Filter (0.2ms or less) is excluded.

*3 Measured by 20MHz oscilloscope or Ripple-Noise meter (equivalent to KEISOKUGIKEN:RM104). Please refer to the instruction manual 1.8.

*4 Drift is the change in DC output for an eight hours period after a half-hour warm-up at 25°C

*5 The output is shut down when the overcurrent protection continues.

*6 Applicable when AUX and remote control (optional) is added.

*7 Please contact us about another class.

* Sound noise may be generated by power supply in case of pulse load.

Features

- High power & peak power
- High efficiency : 94% typ (Input Voltage 230V, Output Voltage 24V)
- Low profile (41mm, 1.61 inch)
- For medical electric equipment (ANSI/AAMI ES60601, EN60601-1 3rd, IEC60601-1-2 4th Ed.)
- Suitable for BF application (Output-FG : 1MOPP, Input-Output : 2MOPP)
- OVC III (according to EN62477-1)
- Complies with SEMI F47 (Refer to Instruction Manual)
- With AUX1 (12V 1A), AUX2 (5V 1A) (Optional)

AEA

Block diagram

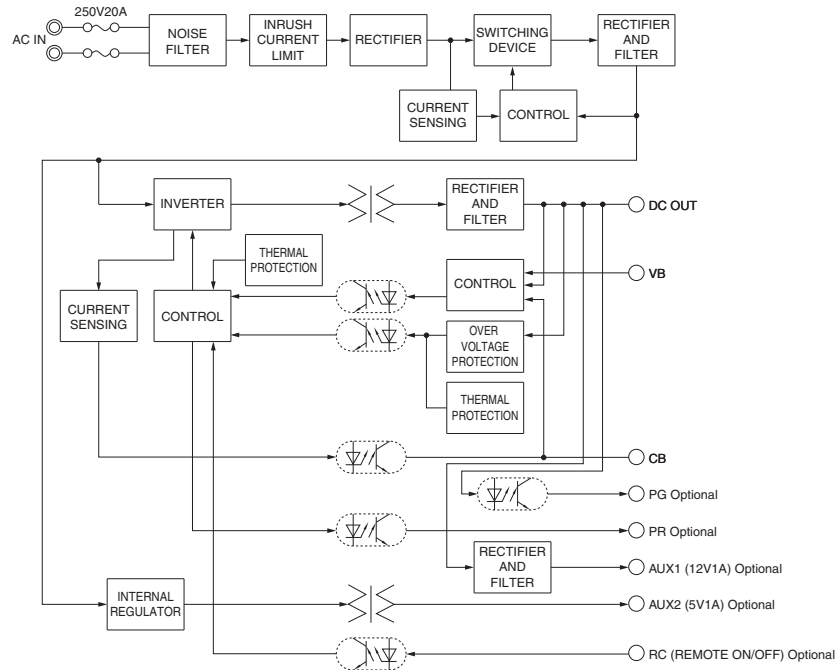

External view

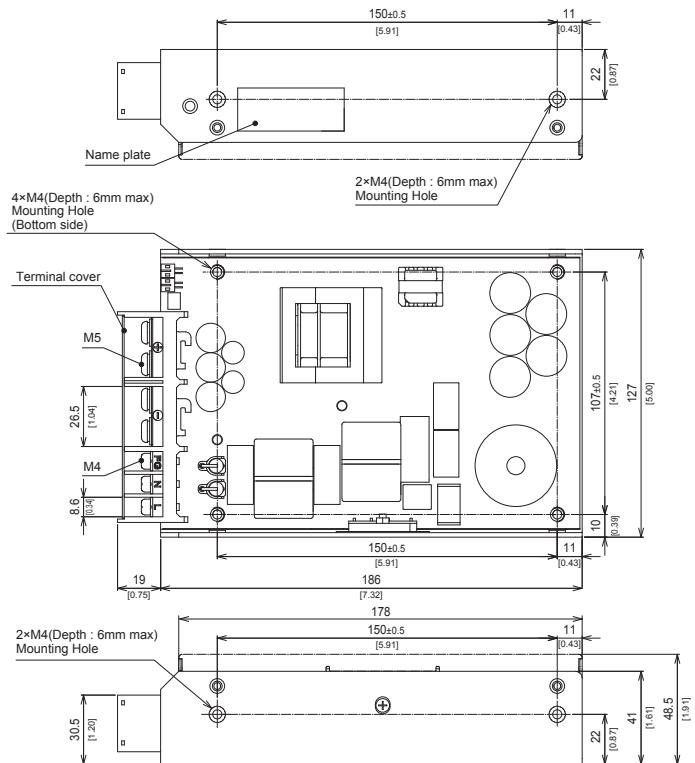
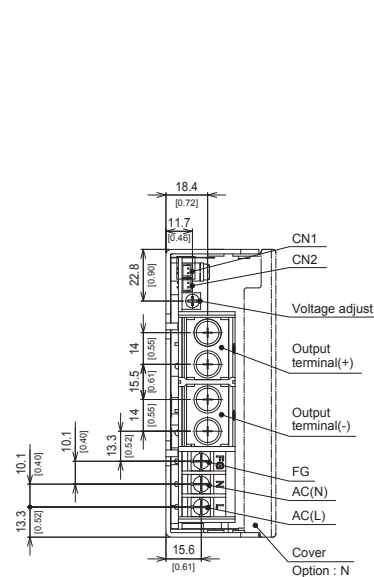

- * Dimensions in mm [inch]
- * Tolerance : ± 1 [± 0.04]
- * Weight : 1.0kg max (with Cover : 1.1kg max)
- * PCB Material/thickness : FR-4/1.6mm [± 0.06]
- * Chassis Material : Aluminum
- * Mounting torque : 1.2N · m max
- * Input and output terminal screw tightening torque
M4 1.6N · m max
M5 2.5N · m max
- * Please connect safety ground to mounting hole on the unit.

AEA800F

AE A 800 F -□□ -□
 ① ② ③ ④ ⑤ ⑥

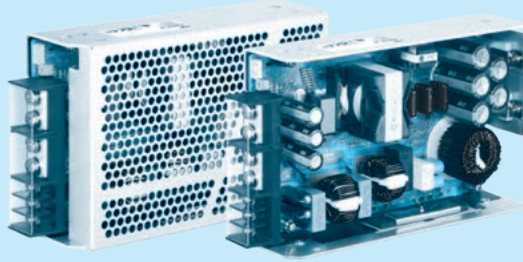

Example recommended EMI/EMC filter
NAC-30-472



High voltage pulse noise type : NAP series
 Low leakage current type : NAM series
 *Use of an EMI/EMC filter is recommended when a power supply is connected with several devices so that additional filtering is necessary.
 *Make sure that your final application will meet the required EMC standard by measuring the EMI level of the power supply used together with an EMI/EMC filter.

- ① Series name
 - ② Single output
 - ③ Output wattage
 - ④ Universal input
 - ⑤ Output voltage
 - ⑥ Optional *1
 - C : with Coating
 - N : with cover
 - T : Vertical terminal block
 - J : Connector type
 - R3 : with Subfeatures (5V1A AUX, 12V1A AUX Remote ON/OFF, Alarm)
 - T5 : UL508
 - P5 : shutdown type overcurrent protection
- For option details, refer to instruction manual 6.1.

Please refer to derating curve, because the rated load current depends on cooling method that is convection cooling or forced air.

*Make sure necessary tests will be carried out on your end equipment with the power supply installed in accordance with any required EMC/EMI regulations.

MODEL	AEA800F-24	AEA800F-36	AEA800F-48
MAX OUTPUT WATTAGE[W]	816	817	816
DC OUTPUT (forced air)	ACIN 100V	24V 25.5 (Peak 54.3) A	48V 12.7 (Peak 27.2) A
	ACIN 230V	24V 34.0 (Peak 72.5) A	36V 22.7 (Peak 48.4) A

SPECIFICATIONS

	MODEL	AEA800F-24	AEA800F-36	AEA800F-48	
INPUT	VOLTAGE[V]	AC85 - 264 1 φ (Output derating is required at AC85 - 170V. See "Derating")			
	CURRENT[A]	ACIN 100V	6.6typ (Io=25.5A)	6.6typ (Io=17.0A)	6.6typ (Io=12.7A)
		ACIN 230V	3.7typ (Io=34.0A)	3.7typ (Io=22.7A)	3.7typ (Io=17.0A)
	FREQUENCY[Hz]	50/60 (45 - 66)			
	EFFICIENCY[%]	ACIN 100V	92.5typ (Io=25.5A)	92.5typ (Io=17.0A)	92.5typ (Io=12.7A)
		ACIN 230V	95.0typ (Io=34.0A)	95.5typ (Io=22.7A)	95.5typ (Io=17.0A)
	POWER FACTOR	ACIN 100V	0.98typ (Io=25.5A)	0.98typ (Io=17.0A)	0.98typ (Io=12.7A)
		ACIN 230V	0.95typ (Io=34.0A)	0.95typ (Io=22.7A)	0.95typ (Io=17.0A)
INRUSH CURRENT[A] *2	ACIN 100V	20/40typ (Io=25.5A)	20/40typ (Io=17.0A)	20/40typ (Io=12.7A)	
	ACIN 230V	40/40typ (Io=34.0A)	40/40typ (Io=22.7A)	40/40typ (Io=17.0A)	
LEAKAGE CURRENT[mA]	0.3max (ACIN 240V 60Hz, Io=100%, According to IEC60601-1)				
OUTPUT	VOLTAGE[V]	24	36	48	
	CURRENT[A]	ACIN 100V	17.6 (Peak 54.3) convection	11.7 (Peak 36.3) convection	8.8 (Peak 27.2) convection
			25.5 (Peak 54.3) forced air	17.0 (Peak 36.3) forced air	12.7 (Peak 27.2) forced air
		ACIN 230V	23.5 (Peak 72.5) convection	15.7 (Peak 48.4) convection	11.8 (Peak 36.3) convection
			34.0 (Peak 72.5) forced air	22.7 (Peak 48.4) forced air	17.0 (Peak 36.3) forced air
	LINE REGULATION[mV]	96max	144max	192max	
	LOAD REGULATION[mV]	150max	240max	300max	
	RIPPLE[mVp-p] *3	0 to +50°C	120max	200max	250max
		-20 to 0°C	230max	300max	400max
	RIPPLE NOISE[mVp-p] *3	0 to +50°C	150max	230max	300max
		-20 to 0°C	250max	350max	550max
	TEMPERATURE REGULATION[mV]	0 to +50°C	240max	360max	480max
	DRIFT[mV] *4	96max	144max	192max	
	START-UP[ms]	750typ			
HOLD-UP[ms]	20typ (ACIN 230V, Io=100%)				
OUTPUT VOLTAGE ADJUSTMENT RANGE[V]	21.6 to 26.4	32.4 to 39.6	43.2 to 52.8		
OUTPUT VOLTAGE SETTING[V]	23.5 to 24.5	35.0 to 37.0	47.0 to 49.0		
PROTECTION CIRCUIT AND OTHERS	OVERCURRENT PROTECTION	Works over 101% of peak current and recovers automatically *5			
	OVERVOLTAGE PROTECTION[V]	30 to 33.6	45 to 50.4	60 to 69.6	
	ALARM	Optional (Input voltage alarm : PR, Output voltage alarm : PG)			
	REMOTE ON/OFF	Optional			
	AUX1	Optional (12V1A forced air)			
AUX2	Optional (5V1A forced air)				
ISOLATION	INPUT-OUTPUT · PR · PG · RC · AUX *6	AC4,000V 1minute, Cutoff current = 10mA, DC500V 50MΩ min (At Room Temperature) 2MOPP			
	INPUT-FG	AC2,000V 1minute, Cutoff current = 10mA, DC500V 50MΩ min (At Room Temperature) 1MOPP			
	OUTPUT · PR · PG · RC · AUX-FG *6	AC1,500V 1minute, Cutoff current = 10mA, DC500V 50MΩ min (At Room Temperature) 1MOPP			
	OUTPUT · AUX1 · PR · PG · RC · AUX2 *6	AC100V 1minute, Cutoff current = 25mA, DC100V 10MΩ min (At Room Temperature)			
ENVIRONMENT	OPERATING TEMP, HUMID. AND ALTITUDE	-20 to +70°C, 20 - 90%RH (Non condensing), 5,000m (16,500feet) max			
	STORAGE TEMP, HUMID. AND ALTITUDE	-20 to +75°C, 20 - 90%RH (Non condensing), 9,000m (30,000feet) max			
	VIBRATION	10 - 55Hz, 19.6m/s ² (2G), 3minutes period, 60minutes each along X, Y and Z axis			
	IMPACT	196.1m/s ² (20G), 11ms, once each X, Y and Z axis			
SAFETY AND NOISE REGULATIONS	AGENCY APPROVALS	UL62368-1, ANSI/AAMI ES 60601-1, C-UL (equivalent to CAN/CSA-C22.2 No.62368-1, CAN/CSA-C22.2 No.60601-1) EN62368-1, EN60601-1 3rd, EN62477-1 (OVCI), UL508 (Optional), Complies with IEC60601-1-2 4th Ed.			
	CONDUCTED NOISE	Complies with FCC Part15 classB, VCCI-B, CISPR32-B, EN55011-B, EN55032-B			
	HARMONIC ATTENUATOR *7	Complies with IEC61000-3-2 (Class A)			
OTHERS	CASE SIZE/WEIGHT	50x127x203.2mm [1.97x5x8 inches] (WxHxD) (without terminal block) / 1.3kg max			
	COOLING METHOD	Convection/Forced air			

*1 The listed options may affect the published standard specifications. Please contact us for detailed product specification

*2 The current of input surge to a built-in EMI/EMS Filter (0.2ms or less) is excluded.

*3 Measured by 20MHz oscilloscope or Ripple-Noise meter (equivalent to KEISOKUGIKEN:RM104). Please refer to the instruction manual 1.8.

*4 Drift is the change in DC output for an eight hours period after a half-hour warm-up at 25°C

*5 The output is shut down when the overcurrent protection continues.

*6 Applicable when AUX and remote control (optional) is added.

*7 Please contact us about another class.

* Sound noise may be generated by power supply in case of pulse load.

Features

- High power & peak power
- High efficiency : 95% typ (Input Voltage 230V, Output Voltage 24V)
- Low profile (50mm, 1.97inch)
- For medical electric equipment (ANSI/AAMI ES60601, EN60601-1 3rd, IEC60601-1-2 4th Ed.)
- Suitable for BF application (Output-FG : 1MOPP, Input-Output : 2MOPP)
- OVC III (according to EN62477-1)
- Complies with SEMI F47 (Refer to Instruction Manual)
- With AUX1 (12V 1A), AUX2 (5V 1A) (Optional)

AEA

Block diagram

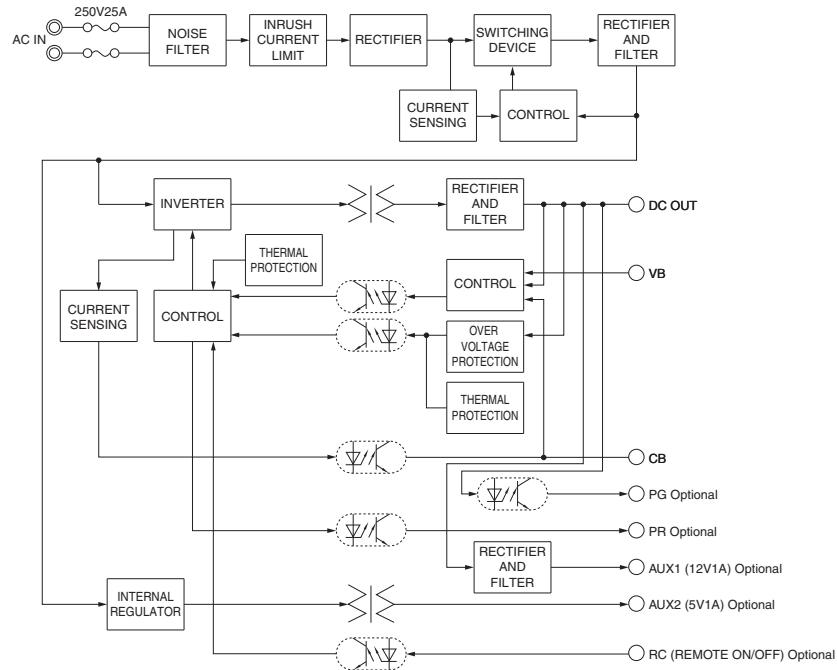

External view

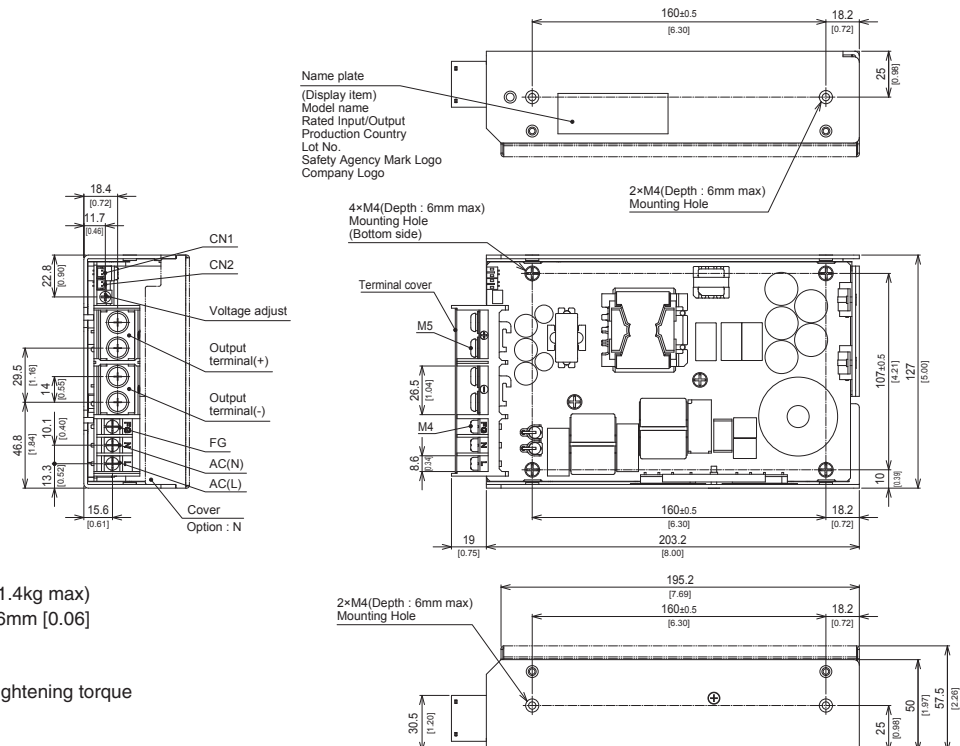

Option

-N : with CoverCover material Aluminum

- * Dimensions in mm [inch]
- * Tolerance : ± 1 [± 0.04]
- * Weight : 1.3kg max (with Cover : 1.4kg max)
- * PCB Material/thickness : FR-4/1.6mm [0.06]
- * Chassis Material : Aluminum
- * Mounting torque : $1.2N \cdot m$ max
- * Input and output terminal screw tightening torque
M4 1.6N · m max
M5 2.5N · m max
- * Please connect safety ground to mounting hole on the unit.

AEA1000F

AE A 1000 F -□□ -□
 ① ② ③ ④ ⑤ ⑥

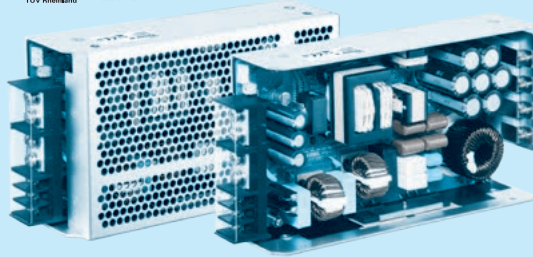

Example recommended EMI/EMC filter
NAC-30-472



High voltage pulse noise type : NAP series
 Low leakage current type : NAM series
 *Use of an EMI/EMC filter is recommended when a power supply is connected with several devices so that additional filtering is necessary.
 *Make sure that your final application will meet the required EMC standard by measuring the EMI level of the power supply used together with an EMI/EMC filter.

- ① Series name
 - ② Single output
 - ③ Output wattage
 - ④ Universal input
 - ⑤ Output voltage
 - ⑥ Optional *1
 - C : with Coating
 - N : with cover
 - T : Vertical terminal block
 - J : Connector type
 - R3 : with Subfeatures (5V1A AUX, 12V1A AUX Remote ON/OFF, Alarm)
 - T5 : UL508
 - P5 : shutdown type overcurrent protection
- For option details, refer to instruction manual 6.1.

Please refer to derating curve, because the rated load current depends on cooling method that is convection cooling or forced air.

*Make sure necessary tests will be carried out on your end equipment with the power supply installed in accordance with any required EMC/EMI regulations.

MODEL	AEA1000F-24	AEA1000F-36	AEA1000F-48
MAX OUTPUT WATTAGE[W]	1,008	1,008	1,008
DC OUTPUT (forced air)	ACIN 100V	24V 31.5 (Peak 75.0) A	36V 21.0 (Peak 50.0) A
	ACIN 230V	24V 42.0 (Peak 100.0) A	36V 28.0 (Peak 66.7) A
		48V 15.8 (Peak 37.5) A	48V 21.0 (Peak 50.0) A

SPECIFICATIONS

	MODEL	AEA1000F-24	AEA1000F-36	AEA1000F-48	
INPUT	VOLTAGE[V]	AC85 - 264 1 φ (Output derating is required at AC85V - 170V. See "Derating")			
	CURRENT[A]	ACIN 100V	8.4typ (Io=31.5A)	8.4typ (Io=21.0A)	8.4typ (Io=15.8A)
		ACIN 230V	4.9typ (Io=42.0A)	4.9typ (Io=28.0A)	4.9typ (Io=21.0A)
	FREQUENCY[Hz]	50/60 (45 - 66)			
	EFFICIENCY[%]	ACIN 100V	92.0typ (Io=31.5A)	92.0typ (Io=21.0A)	92.0typ (Io=15.8A)
		ACIN 230V	95.0typ (Io=42.0A)	95.0typ (Io=28.0A)	95.0typ (Io=21.0A)
	POWER FACTOR	ACIN 100V	0.98typ (Io=31.5A)	0.98typ (Io=21.0A)	0.98typ (Io=15.8A)
		ACIN 230V	0.95typ (Io=42.0A)	0.95typ (Io=28.0A)	0.95typ (Io=21.0A)
	INRUSH CURRENT[A] *2	ACIN 100V	20/40typ (Io=31.5A)	20/40typ (Io=21.0A)	20/40typ (Io=15.8A)
		ACIN 230V	40/40typ (Io=42.0A)	40/40typ (Io=28.0A)	40/40typ (Io=21.0A)
LEAKAGE CURRENT[mA]	0.3max (ACIN 240V 60Hz, Io=100%, According to IEC60601-1)				
OUTPUT	VOLTAGE[V]	24	36	48	
	CURRENT[A]	ACIN 100V	22.5 (Peak 75.0) convection	15.0 (Peak 50.0) convection	11.3 (Peak 37.5) convection
			31.5 (Peak 75.0) forced air	21.0 (Peak 50.0) forced air	15.8 (Peak 37.5) forced air
		ACIN 230V	30.0 (Peak 100.0) convection	20.0 (Peak 66.7) convection	15.0 (Peak 50.0) convection
			42.0 (Peak 100.0) forced air	28.0 (Peak 66.7) forced air	21.0 (Peak 50.0) forced air
	LINE REGULATION[mV]	96max	144max	192max	
	LOAD REGULATION[mV]	150max	240max	300max	
	RIPPLE[mVp-p] *3	0 to +50°C	150max	230max	300max
		-20 to 0°C	230max	350max	450max
		Io=0 to 30%	500max	550max	600max
RIPPLE NOISE[mVp-p] *3	0 to +50°C	300max	350max	400max	
	-20 to 0°C	450max	530max	600max	
	Io=0 to 30%	700max	750max	800max	
TEMPERATURE REGULATION[mV]	0 to +50°C	240max	360max	480max	
DRIFT[mV]	*4	96max	144max	192max	
START-UP[ms]	750typ				
HOLD-UP[ms]	20typ (ACIN 230V, Io=100%)				
OUTPUT VOLTAGE ADJUSTMENT RANGE[V]	22.8 to 26.4	34.2 to 39.6	45.6 to 52.8		
OUTPUT VOLTAGE SETTING[V]	23.5 to 24.5	35.0 to 37.0	47.0 to 49.0		
PROTECTION CIRCUIT AND OTHERS	OVERCURRENT PROTECTION	Works over 101% of peak current and recovers automatically *5			
	OVERVOLTAGE PROTECTION[V]	30 to 33.6	45 to 50.4	60 to 69.6	
	ALARM	Optional (Input voltage alarm : PR, Output voltage alarm : PG)			
	REMOTE ON/OFF	Optional			
	AUX1	Optional (12V1A forced air)			
	AUX2	Optional (5V1A forced air)			
ISOLATION	INPUT-OUTPUT · PR · PG · RC · AUX *6	AC4,000V 1minute, Cutoff current = 10mA, DC500V 50MΩ min (At Room Temperature) 2MOPP			
	INPUT-FG	AC2,000V 1minute, Cutoff current = 10mA, DC500V 50MΩ min (At Room Temperature) 1MOPP			
	OUTPUT · PR · PG · RC · AUX-FG *6	AC1,500V 1minute, Cutoff current = 10mA, DC500V 50MΩ min (At Room Temperature) 1MOPP			
	OUTPUT · AUX1-PR · PG · RC · AUX2 *6	AC100V 1minute, Cutoff current = 25mA, DC100V 10MΩ min (At Room Temperature)			
ENVIRONMENT	OPERATING TEMP., HUMID. AND ALTITUDE	-20 to +70°C, 20 - 90%RH (Non condensing), 5,000m (16,500feet) max			
	STORAGE TEMP., HUMID. AND ALTITUDE	-20 to +75°C, 20 - 90%RH (Non condensing), 9,000m (30,000feet) max			
	VIBRATION	10 - 55Hz, 19.6m/s ² (2G), 3minutes period, 60minutes each along X, Y and Z axis			
	IMPACT	196.1m/s ² (20G), 11ms, once each X, Y and Z axis			
SAFETY AND NOISE REGULATIONS	AGENCY APPROVALS	UL62368-1, ANSI/AAMI ES 60601-1, C-UL (equivalent to CAN/CSA-C22.2 No.62368-1, CAN/CSA-C22.2 No.60601-1) EN62368-1, EN60601-1 3rd, EN62477-1 (OVCI), UL508 (Optional), Complies with IEC60601-1-2 4th Ed.			
	CONDUCTED NOISE	Complies with FCC Part15 classB, VCCI-B, CISPR32-B, EN55011-B, EN55032-B			
	HARMONIC ATTENUATOR *7	Complies with IEC61000-3-2 (Class A)			
OTHERS	CASE SIZE/WEIGHT	50x127x228.6mm [1.97x5x9 inches] (WxHxD) without terminal block /1.5kg max			
	COOLING METHOD	Convection/Forced air			

*1 The listed options may affect the published standard specifications. Please contact us for detailed product specification

*2 The current of input surge to a built-in EMI/EMS Filter (0.2ms or less) is excluded.

*3 Measured by 20MHz oscilloscope or Ripple-Noise meter (equivalent to KEISOKUGIKEN:RM104). Please refer to the instruction manual 1.8.

Ripple and ripple noise spec is change at Io=0 to 30% by burst operation.

*4 Drift is the change in DC output for an eight hours period after a half-hour warm-up at 25°C.

*5 The output is shut down when the overcurrent protection continues.

*6 Applicable when AUX and remote control (optional) is added.

*7 Please contact us about another class.

* Sound noise may be generated by power supply in case of pulse load.

Features

- High power & peak power
- High efficiency : 95% typ (Input Voltage 230V, Output Voltage 24V)
- Low profile (50mm, 1.97inch)
- For medical electric equipment (ANSI/AAMI ES60601, EN60601-1 3rd, IEC60601-1-2 4th Ed.)
- Suitable for BF application (Output-FG : 1MOPP, Input-Output : 2MOPP)
- OVC III (according to EN62477-1)
- Complies with SEMI F47 (Refer to Instruction Manual)
- With AUX1 (12V 1A), AUX2 (5V 1A) (Optional)

AEA

Block diagram

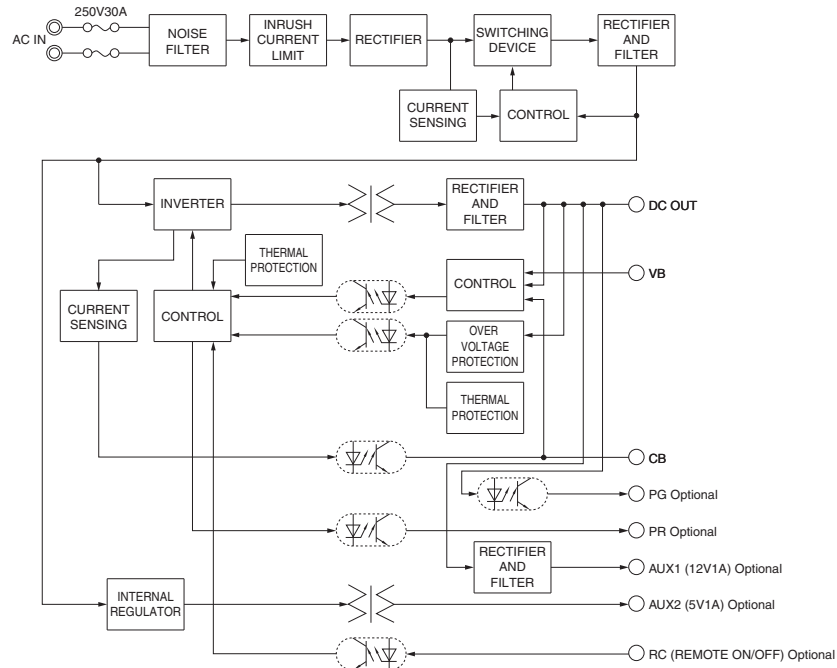

External view

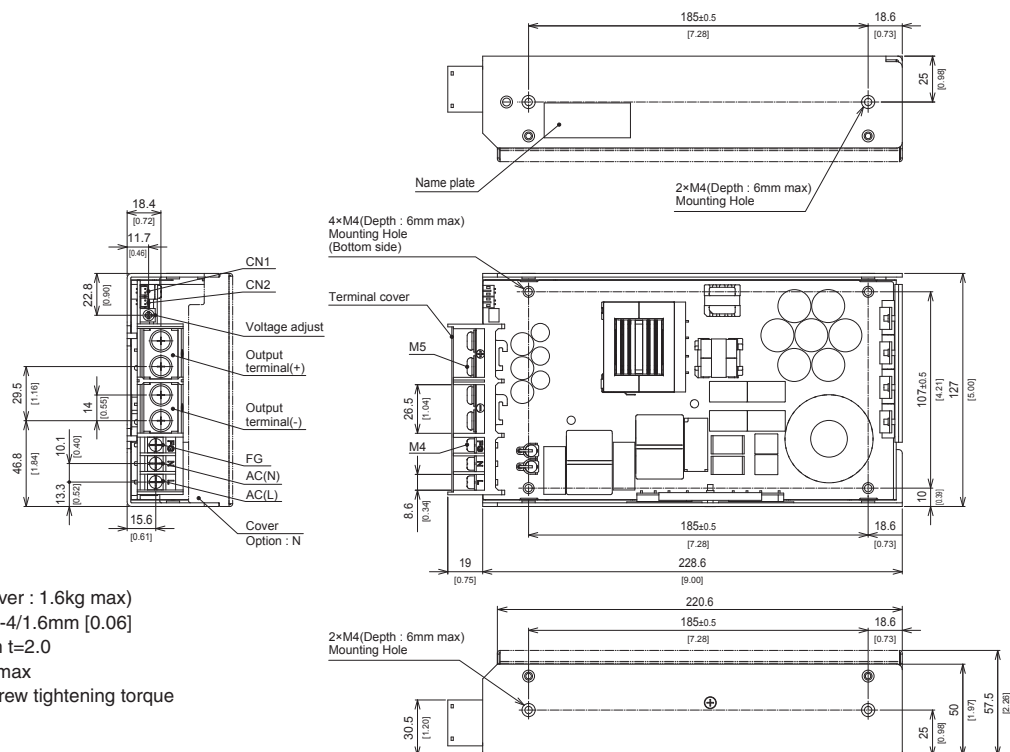

- * Dimensions in mm [inch]
- * Tolerance : ± 1 [± 0.04]
- * Weight : 1.5kg max (with Cover : 1.6kg max)
- * PCB Material/thickness : FR-4/1.6mm [0.06]
- * Chassis Material : Aluminum t=2.0
- * Mounting torque : 1.2N · m max
- * Input and output terminal screw tightening torque
M4 1.6N · m max
M5 2.5N · m max
- * Please connect safety ground to FG terminal on the unit.

Terminal Blocks

AEA

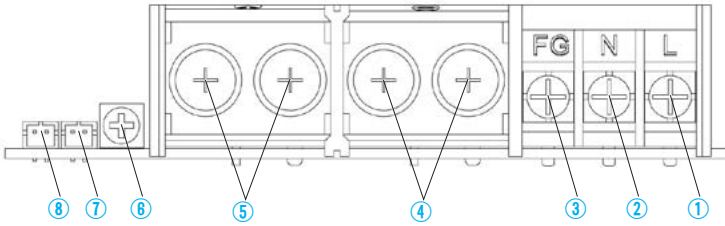

- ① AC (L) (M4)
- ② AC (N) (M4)
- ③ Frame ground (M4)
- ④ - Output (M5)
- ⑤ + Output (M5)
- ⑥ Output voltage adjustable potentiometer
- ⑦ CN2 connector
- ⑧ CN1 connector

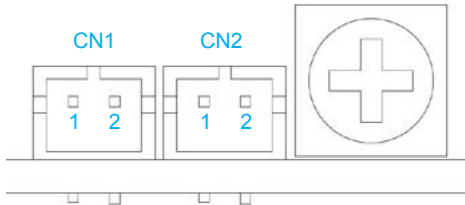

Pin Configuration and Functions of CN1, CN2

Pin No.	Function
1	VB Voltage Balance
2	CB Current Balance

Matching connectors and terminals

Connector	Housing	Terminal	Mfr	
CN1	S2B-PH-K-S	PHR-2	Real : SPH-002T-P0.5S Loose : BPH-002T-P0.5S	J.S.T.

Assembling and Installation Method

Installation method

- The screw should be inserted up to 6mm max from outside of the power supply to keep a distance between inside parts and an isolation.
- When two or more power supplies are used side by side, position them with proper intervals to allow enough air ventilation. Ambient temperature around each power supply should not exceed the temperature range shown in "derating".
- Fix firmly, considering weight, though it can be used by the installation method shown in right figure.

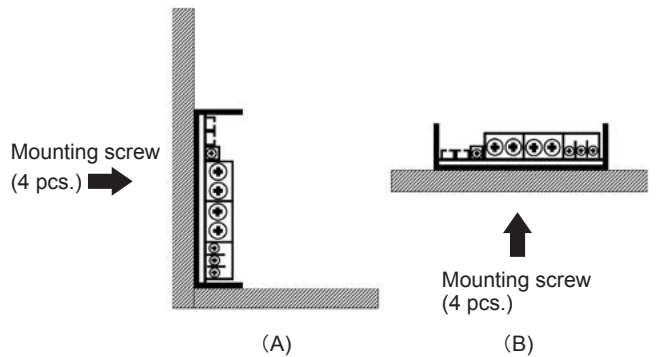
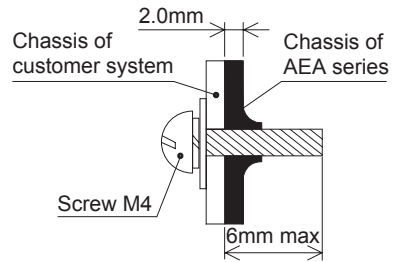

- If mounting on a metal chassis, keep at least 4 mm between the top of the power supply and the chassis for insulation between the components and the chassis. If the distance between the top of the power supply and the chassis is less than 4mm, insert an insulating sheet with reinforced insulation between the power supply unit and metal chassis. The following distance is not satisfactory for cooling condition. Please refer to "Derating" for cooling method.

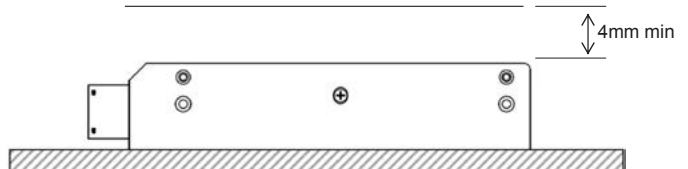

Derating

● AEA600F Derating curve depends on Input voltage

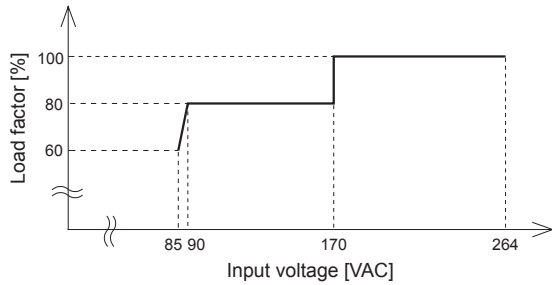

● AEA800F/1000F Derating curve depends on Input voltage

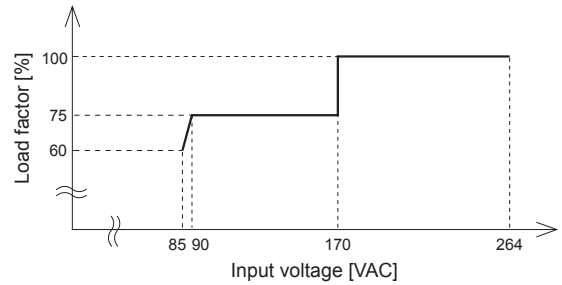

AEA

● AEA600F/800F Ambient temperature Derating Curve (convection cooling)

100% Load factor in each derating curve means the rated current (convection cooling) in Specifications.

In the hatched area, the specification of Ripple and Ripple Noise are different from other area.

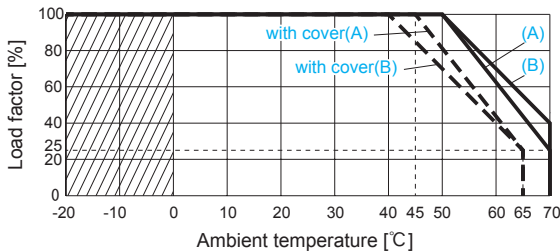

● AEA1000F Ambient temperature Derating Curve (convection cooling)

100% Load factor in each derating curve means the rated current (convection cooling) in Specifications.

In the hatched area, the specification of Ripple and Ripple Noise are different from other area.

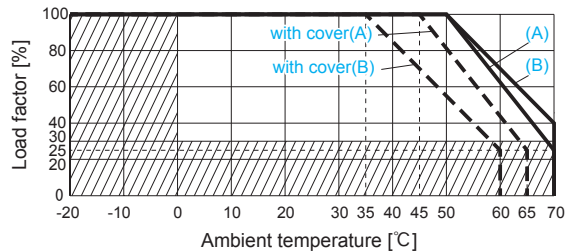

● AEA600F/800F Ambient temperature Derating Curve (forced air cooling)

100% Load factor in each derating curve means the rated current (forced air cooling) in Specifications.

In the hatched area, the specification of Ripple and Ripple Noise are different from other area.

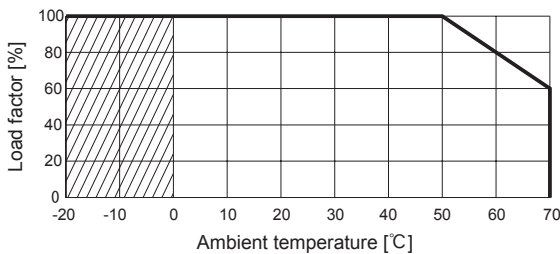

● AEA1000F Ambient temperature Derating Curve (forced air cooling)

100% Load factor in each derating curve means the rated current (forced air cooling) in Specifications.

In the hatched area, the specification of Ripple and Ripple Noise are different from other area.

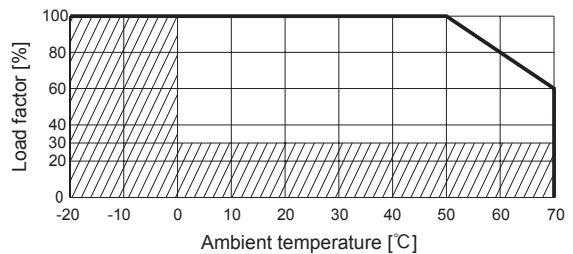

■ Forced air cooling

- AEA600F

① Please satisfy the below temperature at Point A and Point B under the forced air cooling. The Point A/B position is shown in the next figure.

- Point A 90°C or less and Point B 80°C or less at Ta = 50°C
- Point A 110°C or less and Point B 100°C or less at Ta = 70°C

② The forced air should be given to whole of the product.

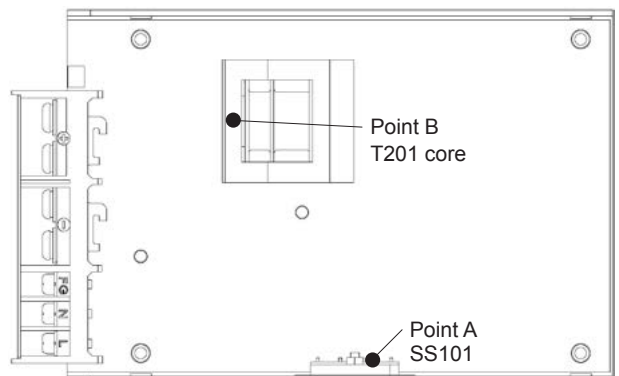
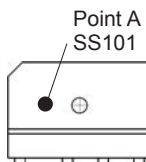

Derating

• AEA800F

① Please satisfy the below temperature at Point A and Point B under the forced air cooling. The Point A/B position is shown in the next figure.

- Point A 90°C or less and Point B 80°C or less at Ta = 50°C
- Point A 110°C or less and Point B 100°C or less at Ta = 70°C

② The forced air should be given to whole of the product.

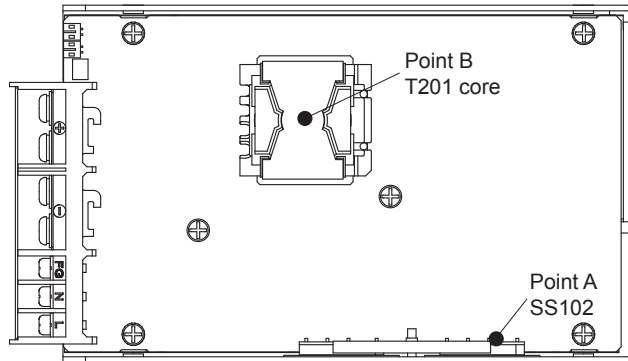
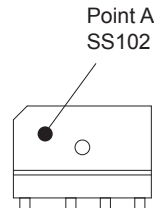

• AEA1000F

① Please satisfy the below temperature at Point A and Point B under the forced air cooling. The Point A/B position is shown in the next figure.

- Point A 90°C or less and Point B 80°C or less at Ta = 50°C
- Point A 110°C or less and Point B 100°C or less at Ta = 70°C

② The forced air should be given to whole of the product.

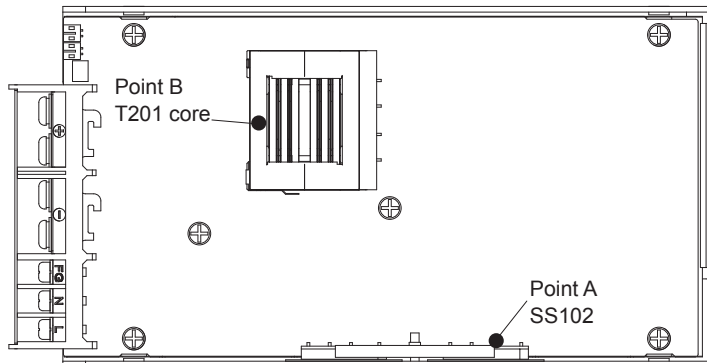
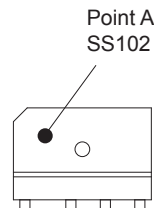

Instruction Manual

◆ It is necessary to read the “Instruction Manual” and “Before using our product” before you use our product.

Instruction Manual <https://www.cosel.co.jp/redirect/catalog/en/AEA/>
 Before using our product <https://en.cosel.co.jp/technical/caution/index.html>

AEA



NOTICE



Basic Characteristics Data

Model	Circuit method	Switching frequency [kHz]	Input current [A] *1	Inrush current protection	PCB/Pattern			Series/Parallel operation availability	
					Material	Single sided	Double sided	Series operation	Parallel operation
AEA600F	Active filter	65	5.7 (Peak 11.1)	Relay	FR-4	-	Yes	Yes	Yes
	LLC resonant converters	70 - 200							
AEA800F	Active filter	65	6.6 (Peak 14.4)	Relay	FR-4	-	Yes	Yes	Yes
	LLC resonant converters	60 - 200							
AEA1000F	Active filter	65	8.4 (Peak 20.6)	Relay	FR-4	-	Yes	Yes	Yes
	LLC resonant converters	70 - 200							

*1 The value of input current is at ACIN 100V and rated load (peak).



HCA-series

HCA

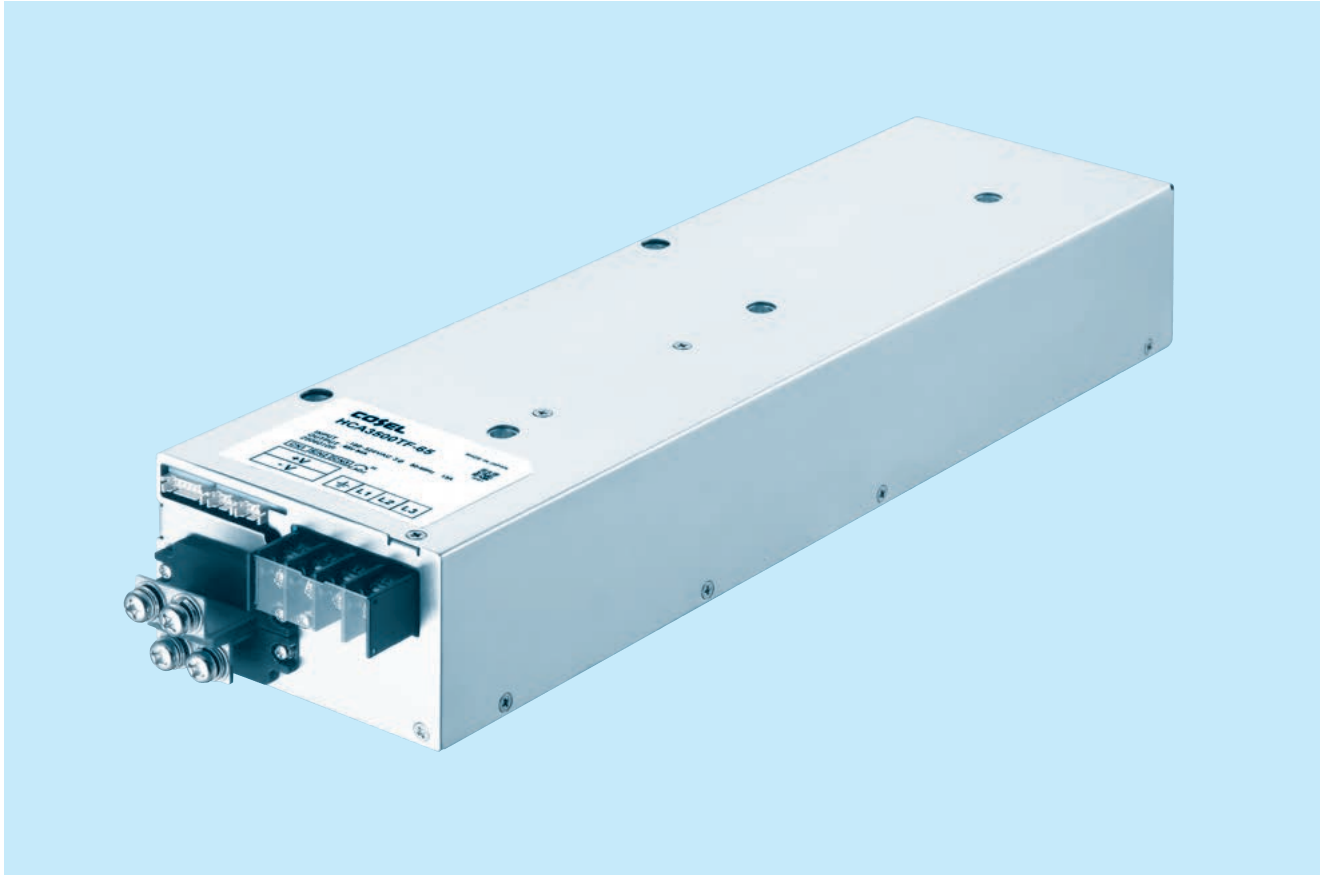

Feature

- Fanless (Conduction cooling)
- Low profile (Meets 1.5U height.)
- Wide input voltage range
- High efficiency
- Parallel Operation / N+1 Parallel Redundancy Operation
- Built-in AUX (12V1A)
- Built-in Alarms
- Remote ON / OFF function

Safety agency approvals

UL62368-1, C-UL (CSA62368-1), EN62368-1

5-year warranty (Refer to Instruction Manual)

CE marking

- Low voltage Directive
- RoHS Directive

UKCA marking

- Electrical Equipment Safety Regulations
- RoHS Regulations

EMI

- Complies with FCC Part 15-A, CISPR32-A, EN55011-A, EN55032-A, VCCI-A

EMS Compliance : EN61204-3, EN61000-6-2

- EN61000-4-2
- EN61000-4-3
- EN61000-4-4
- EN61000-4-5
- EN61000-4-6
- EN61000-4-8
- EN61000-4-11

HCA3500TF

HC A 3500 TF -□□ -□

① ② ③ ④ ⑤ ⑥

- ① Series name
- ② Single output
- ③ Output wattage
- ④ 3 phase full range input
- ⑤ Output voltage
- ⑥ Optional
- R : with Remote ON/OFF
Positive logic control
- G : Low leakage current
- T1: Different shaped output terminal

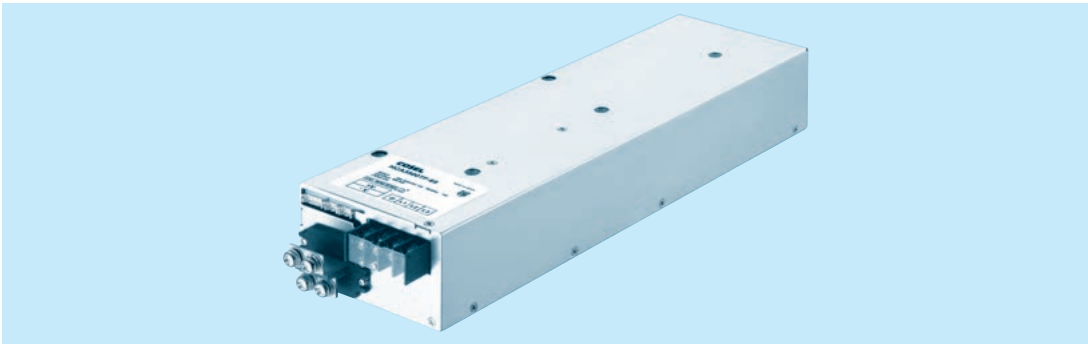

HCA

MODEL	HCA3500TF-48	HCA3500TF-65
MAX OUTPUT WATTAGE[W]	3504	3510
DC OUTPUT	48V 73A	65V 54A

SPECIFICATIONS

	MODEL	HCA3500TF-48	HCA3500TF-65	
INPUT	VOLTAGE[VAC]	*1 180 - 528 3 φ 3-wire (Available to 3 φ 4-wire as well (without N phase))		
	CURRENT[A]	ACIN 200V	11.5typ	
		ACIN 400V	5.7typ	
	FREQUENCY[Hz]	50 / 60 (45 - 66)		
	EFFICIENCY[%]	ACIN 200V (Io=100%)	91typ	92typ
		ACIN 400V (Io=100%)	93typ	94typ
	POWER FACTOR	ACIN 200V (Io=100%)	0.95typ	
		ACIN 400V (Io=100%)	0.94typ	
INRUSH CURRENT[A]	ACIN 200V *2	20 / 30 typ (Io=100%) (Primary / Secondary inrush current) (More than 3 sec. to re-start)		
	ACIN 400V *2	40 / 30 typ (Io=100%) (Primary / Secondary inrush current) (More than 3 sec. to re-start)		
LEAKAGE CURRENT[mA]	3 max (ACIN 480V 60Hz, Io=100%, Complies with IEC62368-1)			
OUTPUT	VOLTAGE[V]	48	65	
	CURRENT[A]	73	54	
	LINE REGULATION[mV]	192max	260max	
	LOAD REGULATION[mV]	300max	450max	
	RIPPLE[mVp-p]	*3 480max	650max	
	RIPPLE NOISE[mVp-p]	*3 720max	950max	
	TEMPERATURE REGULATION[mV]	480max	650max	
	START-UP TIME[ms]	400 typ (ACIN 200/400V, Io=100%)		
	HOLD-UP TIME[ms]	20 typ (ACIN 200V, Io=55%) / 10 typ (ACIN 200V, Io=100%)		
	OUTPUT VOLTAGE ADJUSTMENT RANGE[V] *4	33.60 to 55.20		45.50 to 74.75
48.00 to 48.48		65.00 to 65.65		
PROTECTION CIRCUIT AND OTHERS	OVERCURRENT PROTECTION	Works over 105% of rating (Recovers automatically, Hiccup overcurrent)		
	OVERVOLTAGE PROTECTION[V]	59.04 to 67.20	79.95 to 91.00	
	Remote sensing	Provided		
	REMOTE ON/OFF	Provided		
	DC_OK LAMP	LED (Blue)		
ALARM LAMP	LED (Amber)			
ISOLATION	Input - Output, CN1, CN2, CN3	4,243VAC 1minute, Cutoff current = 15mA, 500VDC 50MΩ min (At room temperature)		
	Input - FG	2,829VAC 1minute, Cutoff current = 15mA, 500VDC 50MΩ min (At room temperature)		
	Output, CN1, CN2 - FG	2,000VAC 1minute, Cutoff current = 10mA, 500VDC 50MΩ min (At room temperature)		
	Output, CN1, CN2 - CN3	500VAC 1minute, Cutoff current = 10mA, 500VDC 50MΩ min (At room temperature)		
	CN3 - FG	500VAC 1minute, Cutoff current = 10mA, 500VDC 50MΩ min (At room temperature)		
ENVIRONMENT	OPERATING TEMP.,HUMID.AND ALTITUDE	0 to +55°C (Baseplate temperature), -10 to +70°C (Ambient temperature), 20 - 90%RH (Non condensing), 3,000m (10,000feet) max		
	STORAGE TEMP.,HUMID.AND ALTITUDE	-20 to +75°C, 20 - 90%RH (Non condensing), 9,000m (30,000 feet) max		
	VIBRATION	10 - 55Hz, 19.6m/s ² (2G), 3minutes period, 60minutes each along X, Y and Z axis		
	IMPACT	196.1m/s ² (20G), 11ms, once each along X, Y and Z axis		
SAFETY AND NOISE REGULATIONS	AGENCY APPROVALS	UL62368-1, EN62368-1, C-UL (equivalent to CAN/CSA-C22.2 No.62368-1)		
	CONDUCTED NOISE	Complies with FCC Part 15-A, FCC Part18-A, CISPR11-A, CISPR32-A, EN55011-A, EN55032-A, VCCI-A		
OTHERS	CASE SIZE/WEIGHT	110 X 65 X 420mm [4.33 X 2.65 X 16.54 inches] (without terminal block and screw) (W X H X D) / 5kg max		
	COOLING METHOD	Conduction cooling (Water-cooled)		

*1 Output derating is required at 180 - 200VAC. Refer to "Derating".
 *2 The value is primary surge. The current of input surge to a built-in EMI/EMS Filter (0.2ms or less) is excluded.
 *3 Measured by 20MHz oscilloscope or Ripple-Noise meter (equivalent to KEISOKUGIKEN : RM104). Please refer to the instruction manual 1.7.
 *4 Output derating is required more than 52.8V (HCA3500TF-48) / 71.5V (HCA3500TF-65). Refer to "Derating"

Features

- Fanless (Conduction cooling)
- Low profile (65mm, 2.65 inch = Meet 1.5U height)
- Wide input voltage range : 3 ϕ 180–528VAC
- Built-in AUX power 12V 1A

- Parallel Operation / N+1 Parallel Redundancy Operation
- High efficiency 94% (at 400VAC input and 65V output)
- Built-in Alarms
- Built-in Oring MOSFET

Block diagram

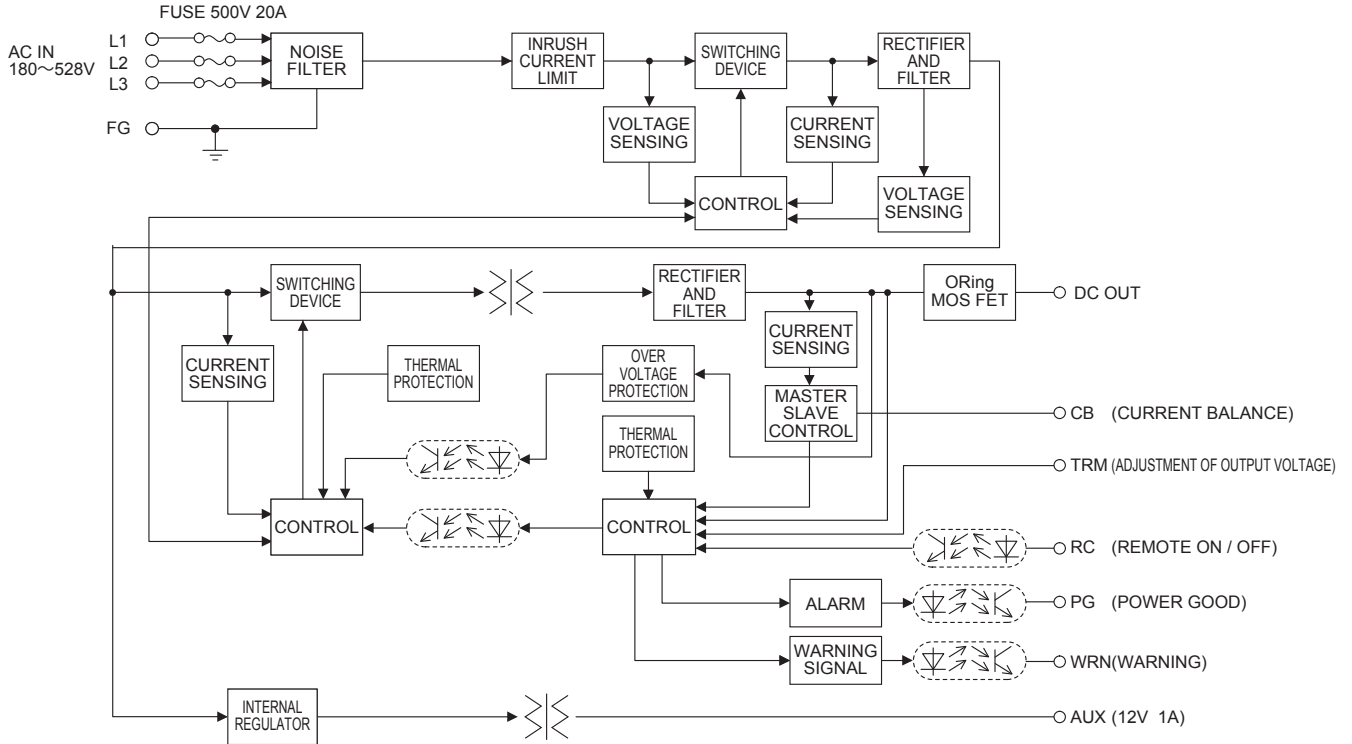

External view

1. Standard model

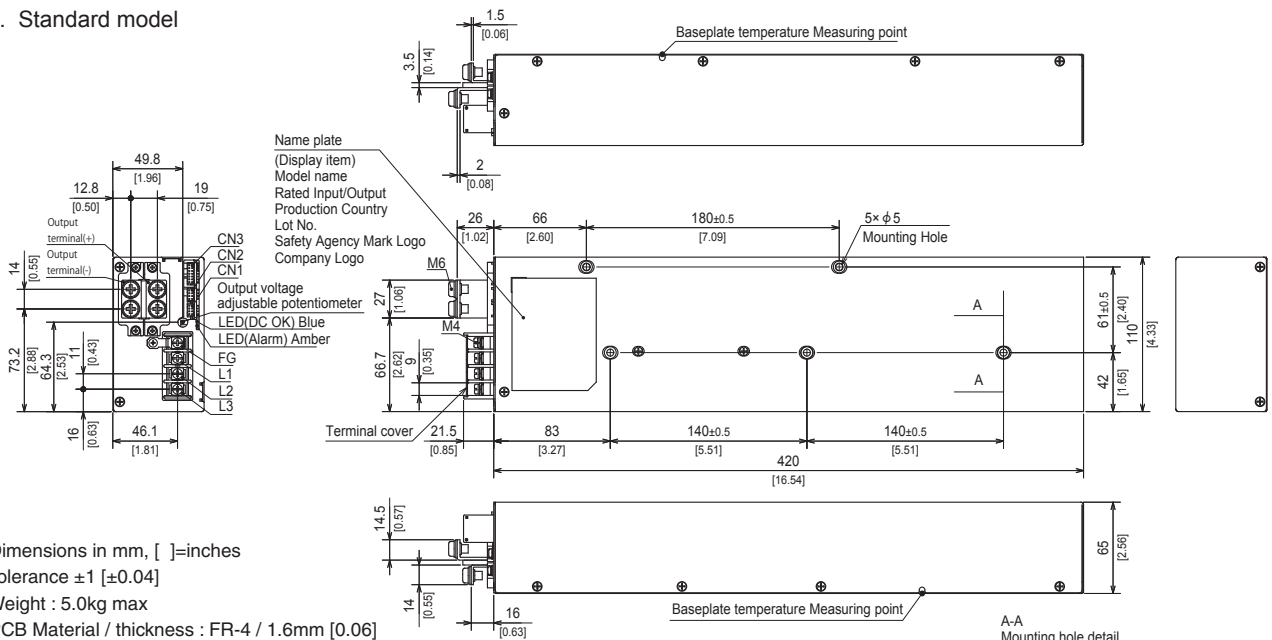

* Dimensions in mm, []=inches

* Tolerance ± 1 [± 0.04]

* Weight : 5.0kg max

* PCB Material / thickness : FR-4 / 1.6mm [0.06]

* Chassis Material : Stainless

* Baseplate Material : Alminum

* Input and output terminal screw tightening torue
: M4 1.6N · m max
M6 4.3N · m max

* Please connect safty ground to FG terminal on the unit.

External view

2. T1 model

HCA

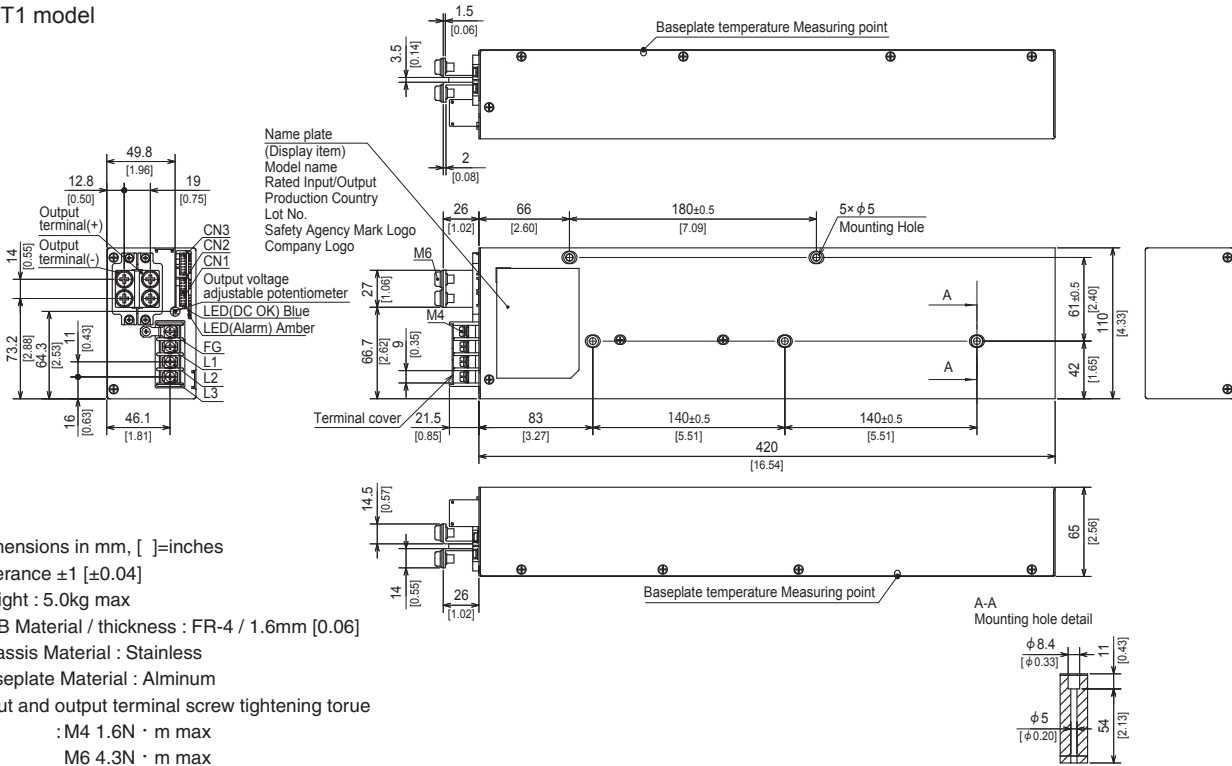

- * Dimensions in mm, []=inches
- * Tolerance ±1 [±0.04]
- * Weight : 5.0kg max
- * PCB Material / thickness : FR-4 / 1.6mm [0.06]
- * Chassis Material : Stainless
- * Baseplate Material : Alminum
- * Input and output terminal screw tightening torue : M4 1.6N · m max
M6 4.3N · m max
- * Please connect safty ground to FG terminal on the unit.

Terminal Blocks

● HCA3500TF

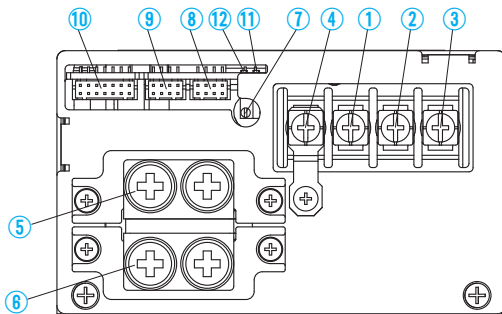

- ①AC (L1)
 - ②AC (L2)
 - ③AC (L3)
 - ④Frame ground (M4)
 - ⑤+ Output (M6)
 - ⑥- Output (M6)
 - ⑦Output voltage adjustable potentiometer
 - ⑧CN1
 - ⑨CN2
 - ⑩CN3
 - ⑪LED for output voltage confirmation (DC_OK) Color : Bule
 - ⑫LED for fault condition detection (ALARM) Color : Orange
- Input Terminals 180–528VAC 3 φ 45–66Hz (M4)
- Connectors

Terminal Blocks

Pin Configuration and Functions

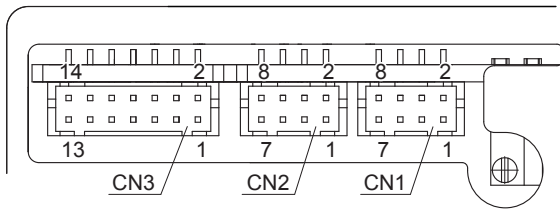

Pin Configuration and Functions of CN1, CN2

Pin No.	Function	Ground level
1	+S : +Remote sensing	COM
2,3	N.C. : No connection	-
4	-S : -Remote sensing	COM
5	CB : Current Balance	COM
6	N.C. : No connection	-
7	VTRM : Adjustment of output voltage	COM
8	COM : Common ground (for signal)	COM

* Each terminal of CN1 and CN2 are connected inside the power supply

Pin Configuration and Functions of CN3

Pin No.	Function	Ground level
1	AUXG : Auxiliary output ground	AUXG
2	SLV_ENG : Enable Slave mode ground	SLV_ENG
3	AUX : Auxiliary output	AUXG
4,5,6,8	N.C. : No connection	-
7	SLV_EN : Enable Slave mode	SLV_ENG
9	RC : Remote ON/OFF	RCG
10	RCG : Remote ON/OFF ground	RCG
11	WRN : Warning signal	WRNG
12	WRNG : Warning signal ground	WRNG
13	PG : Alarm signal	PGG
14	PGG : Alarm signal ground	PGG

Mating connector and terminal

Connector	Housing	Terminal	Mfr.
CN1	S8B-PHDSS	PHDR-8VS	J.S.T.
CN2	S8B-PHDSS	PHDR-8VS	
CN3	S14B-PHDSS	PHDR-14VS	

* The manufacturer prepares only the ratchet hand.

Assembling and Installation Method

- Use with the conduction cooling (e.g. heat dissipation from the aluminum base plate to the attached water-cooled plate).
- Recommended screw is M4. Select a screw length that allows the effective thread to be fastened to the water-cooled plate at least 4 mm.
- The recommended torque for the mounting screws is 0.94–1.25Nm (when the male screw is iron and the water-cooled plate is aluminum or copper).
- The aluminum base plate should be cooled uniformly.
- Use TIM (Thermal interface material) between the aluminum base plate and the water-cooled plate.
It is recommended to use TIM with a thermal conductivity of 1 W/mK or more.
- The unit can be mounted in any direction. When two or more power supplies are used side by side, position them with proper intervals to allow enough air ventilation. Aluminum base plate temperature of each power supply should not exceed the temperature range shown in “derating”.

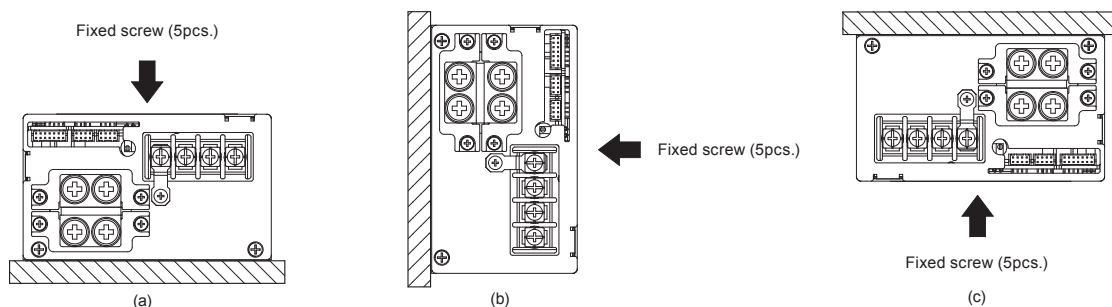

Derating

● Derating curve depends on Input voltage

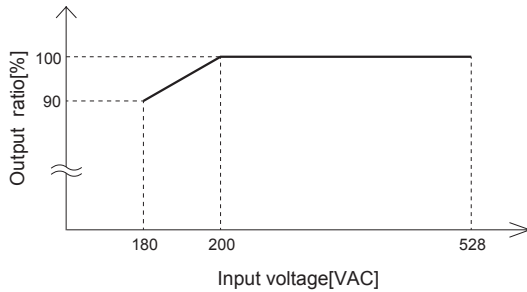

● Derating curve depends on Output voltage

- The unit should be used by the conduction cooling such as the water-cooled plate.
- The temperature of both points A and B has to be within the derating curve.
- Ambient temperature must keep between -10°C and 70°C.

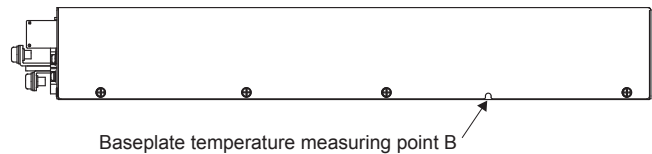
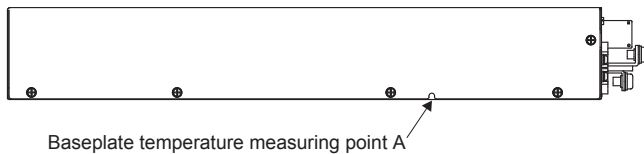
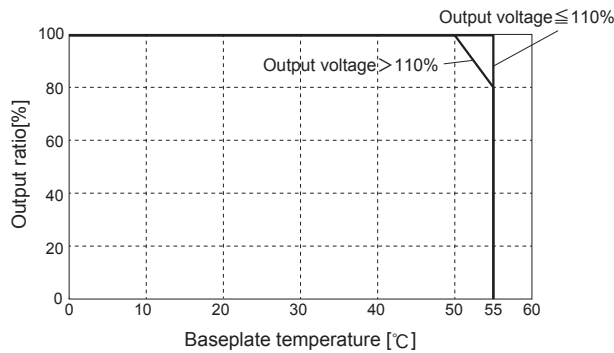

Instruction Manual

◆ It is necessary to read the "Instruction Manual" and "Before using our product" before you use our product.

Instruction Manual <https://www.cosec.co.jp/redirect/catalog/en/HCA/>
 Before using our product <https://en.cosec.co.jp/technical/caution/index.html>



Basic Characteristics Data

Model	Circuit method	Switching frequency [kHz]	Input current [A] *	Inrush current protection	PCB/Pattern			Series/Parallel operation availability	
					Material	Single sided	Double sided	Series operation	Parallel operation
HCA3500TF	Active filter	130	11.5	IGBT	FR-4		Yes	Yes	Yes
	Phase-shift Full-bridge converter	(Primary) 95 (Secondary) 190							

* The value of input current is at 200VAC input and rated load.



1U

Power
Factor
CorrectionSafety
Approvals

EMI

Inrush
current
limiting

OCP



OVP

Remote
ON/OFFParallel
OperationHigh output
voltage

FETA-series

FETA

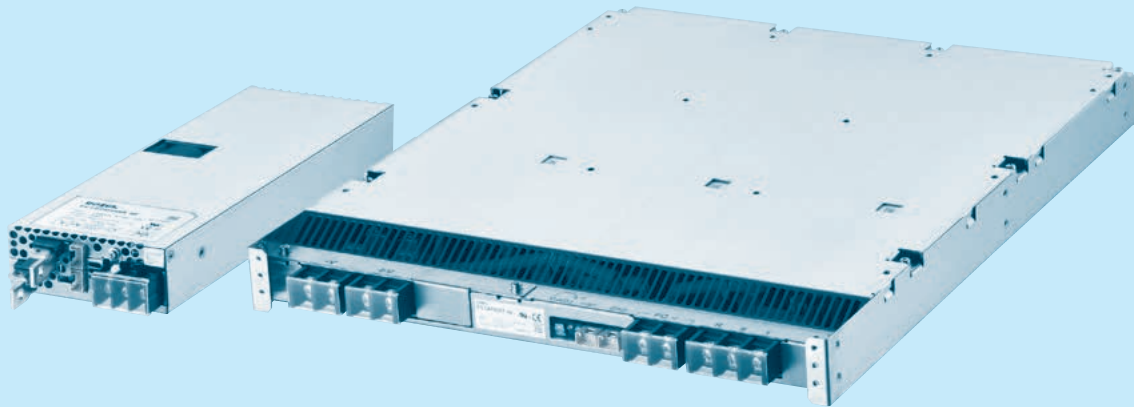

Feature

High power density
 Low profile (Meets 1U height.)
 High output voltage
 (FETA3000BC-250, FETA7000T-144, FETA7000ST-144)
 High efficiency
 High-speed response (FETA3000BC)
 Harmonic attenuator
 (FETA2500BA, 3000BA, 3000BC, 7000ST : Complies with
 IEC61000-3-2 Class A
 FETA7000T : Complies with IEC61000-3-12)
 Complies with SEMI F47
 Parallel Operation / Parallel Redundancy Operation
 Alarm signals, Remote ON / OFF and other functions

Safety agency approvals

UL62368-1, C-UL(CSA62368-1), EN62368-1

EMI

Complies with FCC Part 15-A, CISPR32-A, EN55032-A,
 VCCI-A
 (FETA7000ST : Complies with FCC Part 15-A, CISPR32-A,
 EN55032-A, VCCI-A by connecting an external EMI/EMC filter)

3-year warranty (Refer to Instruction Manual)

CE marking

Low voltage Directive
 RoHS Directive

UKCA marking

Electrical Equipment Safety Regulations
 RoHS Regulations

EMS Compliance : EN61204-3, EN61000-6-2

EN61000-4-2
 EN61000-4-3
 EN61000-4-4
 EN61000-4-5
 EN61000-4-6
 EN61000-4-8
 EN61000-4-11

FETA2500BA

FET A 2500 B A -□□ -□

① ② ③ ④ ⑤ ⑥ ⑦



Example recommended EMI/EMC filter
NAC-20-472



High voltage pulse noise type : NAP series
Low leakage current type : NAM series
* A higher current rating EMI/EMC filter may be recommended in view of the other devices that could be connected in parallel with the power supply.

- ① Series name
- ② Single output
- ③ Output wattage
- ④ 200/230V input
- ⑤ Version
- ⑥ Output voltage
- ⑦ Optional
- F2: Reverse air exhaust
- R: with Remote ON/OFF
- Positive logic control

*Make sure necessary tests will be carried out on your end equipment with the power supply installed in accordance with any required EMC/EMI regulations.

MODEL	FETA2500BA-36	FETA2500BA-48
MAX OUTPUT WATTAGE[W]	1980	2496
DC OUTPUT	36V 55A	48V 52A

SPECIFICATIONS

	MODEL	FETA2500BA-36	FETA2500BA-48	
INPUT	VOLTAGE[V]	AC170 - 264 1 φ (Output derating is required at AC170V - 180V. Refer to "Derating")		
	CURRENT[A]	ACIN 200V	11.3typ	
	FREQUENCY[Hz]		50 / 60 (47 - 63)	
	EFFICIENCY[%]	ACIN 230V	80typ (Io=10%)	83typ (Io=10%)
			87typ (Io=20%)	89typ (Io=20%)
			91typ (Io=50%)	92.5typ (Io=50%)
			90typ (Io=100%)	91.5typ (Io=100%)
POWER FACTOR	ACIN 230V	0.98typ (Io=100%)		
INRUSH CURRENT[A]	ACIN 200V	*2 20max / 60max (Primary inrush current /Secondary inrush current) (More than 10 sec. to re-start)		
LEAKAGE CURRENT[mA]		0.85max (ACIN 240V 60Hz, Io=100%, According to IEC62368-1)		
OUTPUT	VOLTAGE[V]	36	48	
	CURRENT[A]	ACIN 170V-180V	Output derating is required at ACIN 180V or less (refer to "Derating")	
		ACIN 180V-264V	55	52
	LINE REGULATION[mV]		144max	192max
	LOAD REGULATION[mV]		360max	480max
	RIPPLE[mVp-p]	0 to +50°C	*3 300max	360max
		-10 to 0°C	*3 360max	480max
	RIPPLE NOISE[mVp-p]	0 to +50°C	*3 360max	480max
		-10 to 0°C	*3 480max	600max
	TEMPERATURE REGULATION[mV]	0 to +50°C	360max	480max
		-10 to +50°C	440max	600max
	DRIFT[mV]	*4	144max	192max
	START-UP TIME[s]		1.7max (ACIN 200V, Io=100%)	
	HOLD-UP TIME[ms]	ACIN 200V	10typ (Io=100%)	
20typ (Io=50%)				
OUTPUT VOLTAGE ADJUSTMENT RANGE[V]	*5	28.80 - 39.60	38.40 - 52.80 *6	
OUTPUT VOLTAGE SETTING[V]		36.00 - 37.44	48.00 - 49.92	
PROTECTION CIRCUIT AND OTHERS	OVERCURRENT PROTECTION	Activate over 105% - 120% of rated current and recovers automatically. (Output voltage shuts down when the output voltage continuously drops due to overcurrent protection.) *7		
	OVERVOLTAGE PROTECTION[V]	*7	42.00 - 45.00	
	DC_OK LAMP		LED (Green)	
	ALARM LAMP		LED (Amber)	
	REMOTE ON/OFF		Provided	
ISOLATION	INPUT-OUTPUT·AUX·RC·WRN·PG	AC3,000V 1minute, Cutoff current = 25mA, DC500V 50MΩ min (At room temperature)		
	INPUT-FG	AC2,000V 1minute, Cutoff current = 25mA, DC500V 50MΩ min (At room temperature)		
	OUTPUT·AUX·RC·WRN·PG-FG	AC500V 1minute, Cutoff current = 100mA, DC500V 50MΩ min (At room temperature)		
	OUTPUT-AUX·RC·WRN·PG	AC100V 1minute, Cutoff current = 100mA, DC100V 50MΩ min (At room temperature)		
ENVIRONMENT	OPERATING TEMP.,HUMID.AND ALTITUDE	-10 to +70°C (Refer to "Derating"), 20 - 90%RH (Non condensing), 3,000m (10,000 feet) max		
	STORAGE TEMP.,HUMID.AND ALTITUDE	-20 to +85°C, 20 - 90%RH (Non condensing), 9,000m (30,000 feet) max		
	VIBRATION	10 - 55Hz, 19.6m/s² (2G), 3minutes period, 60minutes each along X, Y and Z axis		
	IMPACT	196.1m/s² (20G), 11ms, once each along X, Y and Z axis		
SAFETY AND NOISE REGULATIONS	AGENCY APPROVALS	UL62368-1, C-UL (CSA62368-1), EN62368-1		
	CONDUCTED NOISE	Complies with FCC Part 15-A, CISPR32-A, EN55032-A, VCCI-A		
	HARMONIC ATTENUATOR	Complies with IEC61000-3-2 Class A *8		
OTHERS	CASE SIZE/WEIGHT	*9	102 X 41 X 340mm [4.02 X 1.61 X 13.39 inches] (W X H X D) / 2.3kg max	
	COOLING METHOD		Forced cooling (internal fan)	

*1 AUX output power is not included.
 *2 The current of input surge to a built-in noise filter (0.2ms or less) is excluded.
 *3 Measured by 500MHz oscilloscope.
 Ripple and ripple noise is measured on measuring board with capacitor of 22μF within 150mm from the output terminal.
 *4 Drift is the change in DC output for an eight hour period after a half-hour warm-up at 25°C, with the input voltage held constant at the rated input/output.
 *5 Can't be used above the rated output current and the rated output power.
 *6 When the output voltage is adjusted to higher than 49.92V and the load factor is over 70% of the rated current, if the load current changes quickly (< 200msec), the output voltage drops approximately 5V below the setting voltage.
 *7 Output voltage recovers from protection by shutting down the input voltage and waiting more than 10 seconds then turning on AC input again, or turning off the output voltage by remote control.
 *8 Please contact us about another class.
 *9 Case size contains neither the terminal blocks, connector and screw.
 To meet the specifications, do not operate over-loaded condition.
 A sound may occur from power supply at peak loading.

Block diagram

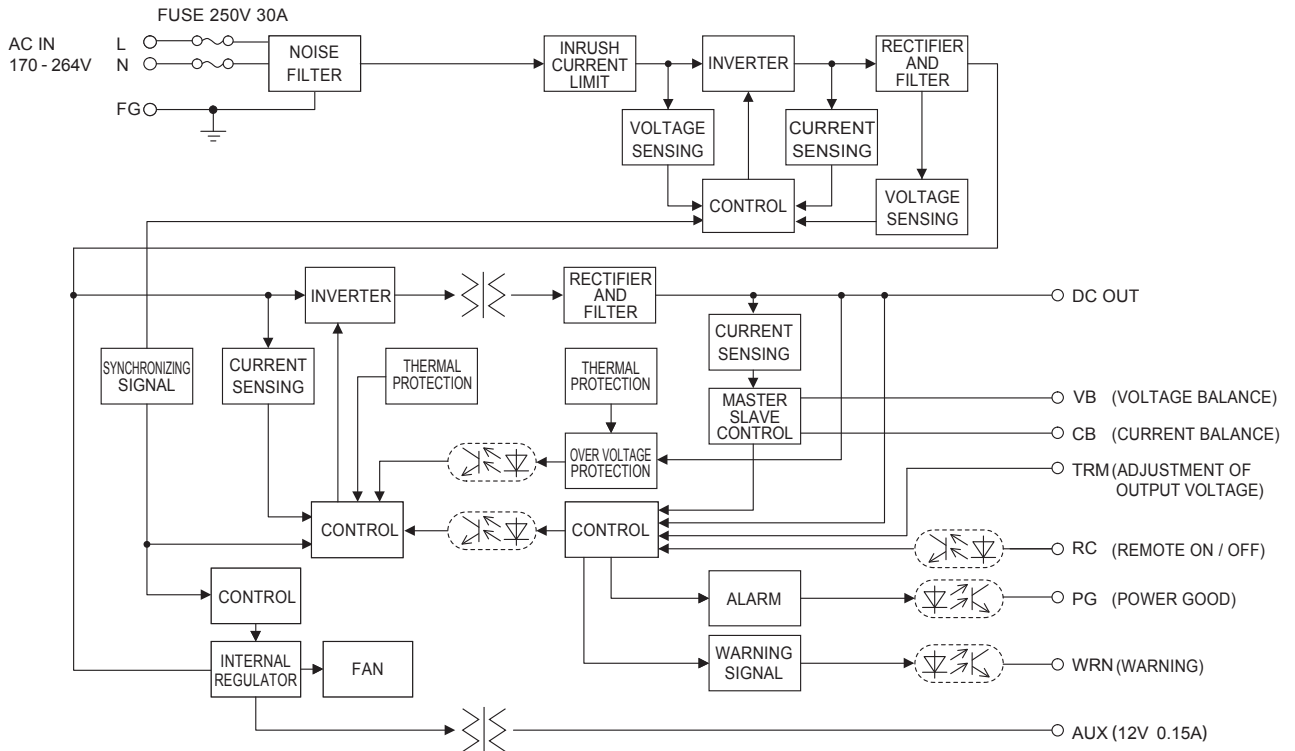

External view

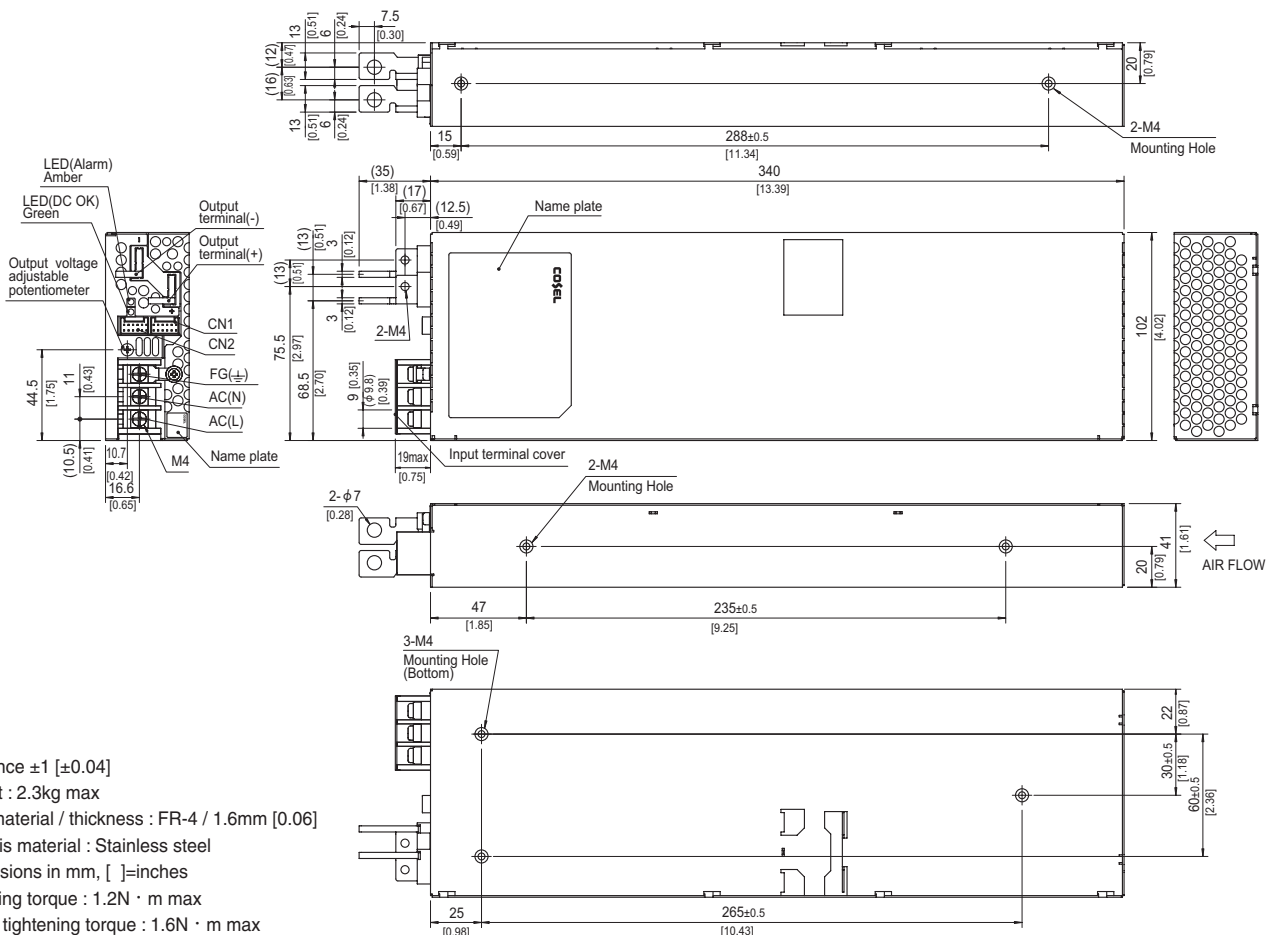

- * Tolerance ± 1 [± 0.04]
- * Weight : 2.3kg max
- * PCB material / thickness : FR-4 / 1.6mm [0.06]
- * Chassis material : Stainless steel
- * Dimensions in mm, []=inches
- * Mounting torque : 1.2N · m max
- * Screw tightening torque : 1.6N · m max
- * Please connect safety ground to FG terminal on the unit.

FETA3000BA

FET A 3000 B A -□□ -□

① ② ③ ④ ⑤ ⑥ ⑦



Example recommended EMI/EMC filter
NAC-20-472



High voltage pulse noise type : NAP series
Low leakage current type : NAM series
* A higher current rating EMI/EMC filter may be recommended in view of the other devices that could be connected in parallel with the power supply.

- ① Series name
 - ② Single output
 - ③ Output wattage
 - ④ 200/230V input
 - ⑤ Version
 - ⑥ Output voltage
 - ⑦ Optional
- R: with Remote ON/OFF
Positive logic control

*Make sure necessary tests will be carried out on your end equipment with the power supply installed in accordance with any required EMC/EMI regulations.

MODEL	FETA3000BA-48
MAX OUTPUT WATTAGE[W]	*1 2976
DC OUTPUT	48V 62A

SPECIFICATIONS

	MODEL	FETA3000BA-48	
INPUT	VOLTAGE[V]	AC170 - 264 1 φ (Output derating is required at AC170V - 180V. Refer to "Derating")	
	CURRENT[A]	ACIN 200V 16.6typ	
	FREQUENCY[Hz]	50 / 60 (47 - 63)	
	EFFICIENCY[%]	ACIN 230V	82typ (Io=10%)
			90typ (Io=20%)
			93typ (Io=50%)
POWER FACTOR	ACIN 230V 0.98typ (Io=100%)		
INRUSH CURRENT[A]	ACIN 200V *2 20max / 80max (Primary inrush current /Secondary inrush current) (More than 10 sec. to re-start)		
LEAKAGE CURRENT[ma]	0.85max (ACIN 240V 60Hz, Io=100%, According to IEC62368-1)		
OUTPUT	VOLTAGE[V]	48	
	CURRENT[A]	ACIN 170V-180V	Output derating is required at ACIN 180V or less (refer to "Derating")
		ACIN 180V-264V	62
	LINE REGULATION[mV]	192max	
	LOAD REGULATION[mV]	480max	
	RIPPLE[mVp-p]	0 to +50°C *3	360max (Vo=15 - 52.8[V]) *4
		-10 to 0°C *3	480max (Vo=15 - 52.8[V]) *4
	RIPPLE NOISE[mVp-p]	0 to +50°C *3	600max (Vo=15 - 52.8[V]) *4
		-10 to 0°C *3	720max (Vo=15 - 52.8[V]) *4
	TEMPERATURE REGULATION[mV]	0 to +50°C	480max
		-10 to +50°C	600max
	DRIFT[mV]	*4	192max
	START-UP TIME[s]	*5	1.7max (ACIN 200V, Io=100%)
HOLD-UP TIME[ms]	ACIN 200V	10typ (Io=100%)	
		20typ (Io=50%)	
OUTPUT VOLTAGE ADJUSTMENT RANGE[V]	*6	38.40 - 52.80	
OUTPUT VOLTAGE SETTING[V]		48.00 - 49.00	
PROTECTION CIRCUIT AND OTHERS	OVERCURRENT PROTECTION	Activate over 105% - 120% of rated current and recovers automatically. (Output voltage shuts down when the output voltage continuously drops due to overcurrent protection.) *7	
	OVERVOLTAGE PROTECTION[V]	*7 56.00 - 60.00	
	DC_OK LAMP	LED (Green)	
	ALARM LAMP	LED (Amber)	
	REMOTE ON/OFF	Provided	
ISOLATION	INPUT-OUTPUT·AUX·RC·WRN·PG	AC3,000V 1minute, Cutoff current = 25mA, DC500V 50MΩ min (At room temperature)	
	INPUT-FG	AC2,000V 1minute, Cutoff current = 25mA, DC500V 50MΩ min (At room temperature)	
	OUTPUT·AUX·RC·WRN·PG-FG	AC500V 1minute, Cutoff current = 100mA, DC500V 50MΩ min (At room temperature)	
	OUTPUT-AUX·RC·WRN·PG	AC100V 1minute, Cutoff current = 100mA, DC100V 50MΩ min (At room temperature)	
ENVIRONMENT	OPERATING TEMP.,HUMID.AND ALTITUDE	-10 to +70°C (Refer to "Derating"), 20 - 90%RH (Non condensing), 3,000m (10,000 feet) max	
	STORAGE TEMP.,HUMID.AND ALTITUDE	-20 to +85°C, 20 - 90%RH (Non condensing), 9,000m (30,000 feet) max	
	VIBRATION	10 - 55Hz, 19.6m/s ² (2G), 3minutes period, 60minutes each along X, Y and Z axis	
	IMPACT	196.1m/s ² (20G), 11ms, once each along X, Y and Z axis	
SAFETY AND NOISE REGULATIONS	AGENCY APPROVALS	UL62368-1, C-UL (CSA62368-1), EN62368-1	
	CONDUCTED NOISE	Complies with FCC Part 15-A, CISPR32-A, EN55032-A, VCCI-A	
	HARMONIC ATTENUATOR	Complies with IEC61000-3-2 Class A *8	
OTHERS	CASE SIZE/WEIGHT	*9 102 X 41 X 340mm [4.02 X 1.61 X 13.39 inches] (W X H X D) / 2.3kg max	
	COOLING METHOD	Forced cooling (internal fan)	

*1 AUX output power is not included.
 *2 The current of input surge to a built-in noise filter (0.2ms or less) is excluded.
 *3 Measured by 500MHz oscilloscope.
 *4 The output voltage should not be adjusted to 15V or less because the ripple and ripple noise would be out of specs and the unit would make the audible noise.
 *5 Drift is the change in DC output for an eight hour period after a half-hour warm-up at 25°C, with the input voltage held constant at the rated input/output.
 *6 Can't be used above the rated output current and the rated output power.
 *7 Output voltage recovers from protection by shutting down the input voltage and waiting more than 10 seconds then turning on AC input again, or turning off the output voltage by remote control.
 *8 Please contact us about another class.
 *9 Case size contains neither the terminal blocks, connector and screw.
 * To meet the specifications, do not operate over-loaded condition.
 * A sound may occur from power supply at peak loading.

Block diagram

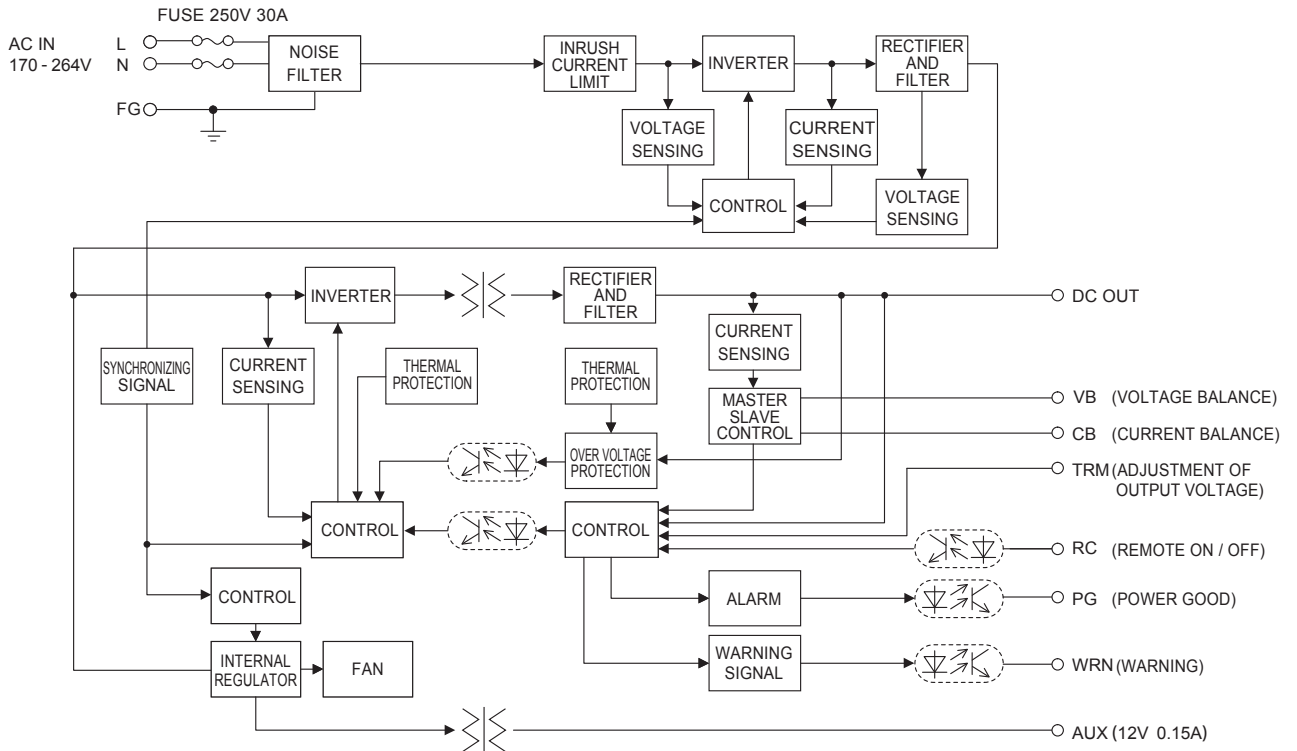

External view

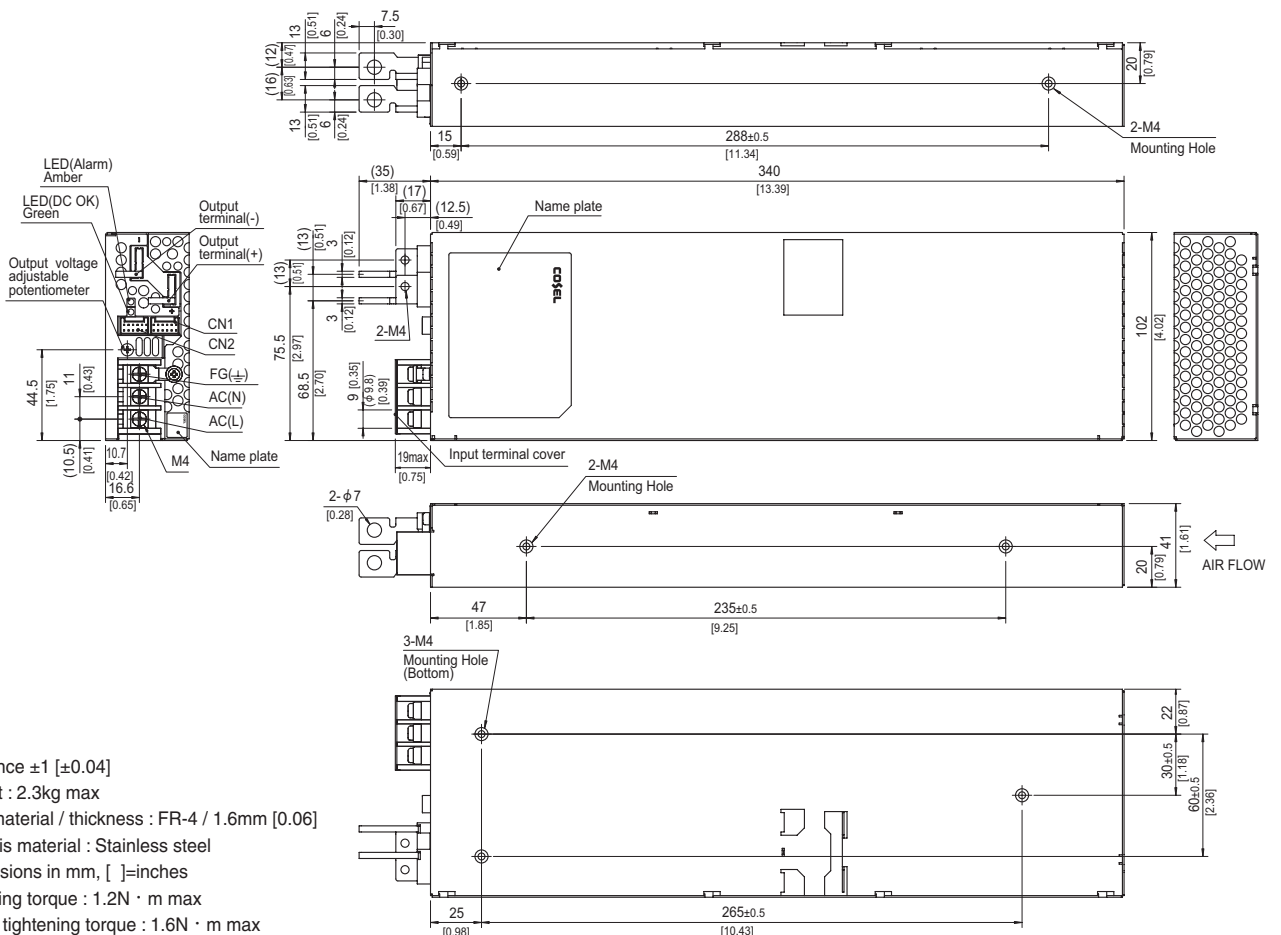

- * Tolerance ± 1 [± 0.04]
- * Weight : 2.3kg max
- * PCB material / thickness : FR-4 / 1.6mm [0.06]
- * Chassis material : Stainless steel
- * Dimensions in mm, []=inches
- * Mounting torque : 1.2N · m max
- * Screw tightening torque : 1.6N · m max
- * Please connect safety ground to FG terminal on the unit.

FETA3000BC

FET A 3000 B C -□□ -□

① ② ③ ④ ⑤ ⑥ ⑦



Example recommended EMI/EMC filter
NAC-20-472



High voltage pulse noise type : NAP series
Low leakage current type : NAM series
* A higher current rating EMI/EMC filter may be recommended in view of the other devices that could be connected in parallel with the power supply.

- ① Series name
 - ② Single output
 - ③ Output wattage
 - ④ 200/230V input
 - ⑤ Version
 - ⑥ Output voltage
 - ⑦ Optional
- R: with Remote ON/OFF Positive logic control

*Make sure necessary tests will be carried out on your end equipment with the power supply installed in accordance with any required EMC/EMI regulations.

MODEL	FETA3000BC-250
MAX OUTPUT WATTAGE[W]	3000
DC OUTPUT	250V 12A

SPECIFICATIONS

MODEL		FETA3000BC-250
INPUT	VOLTAGE[V]	AC170 - 264 1 φ (Output derating is required at AC170V - 180V. Refer to "Derating")
	CURRENT[A]	ACIN 200V 16.8typ
	FREQUENCY[Hz]	50 / 60 (47 - 63)
	EFFICIENCY[%]	ACIN 230V 93typ (Io=50%) 91.5typ (Io=100%)
	POWER FACTOR	ACIN 230V 0.98typ (Io=100%)
	INRUSH CURRENT[A]	ACIN 200V *1 20max / 80max (Primary inrush current /Secondary inrush current) (More than 10 sec. to re-start)
	LEAKAGE CURRENT[mA]	0.85max (ACIN 240V 60Hz, Io=100%, According to IEC62368-1)
OUTPUT	VOLTAGE[V]	250
	CURRENT[A]	ACIN 170V-180V Output derating is required at ACIN 180V or less (refer to "Derating") ACIN 180V-264V 12
	LINE REGULATION[V]	1.0max
	LOAD REGULATION[V]	2.5max
	RIPPLE[Vp-p]	0 to +40°C *2 12max -10 to 0°C *2 13.2max
	RIPPLE NOISE[Vp-p]	0 to +40°C *2 12max -10 to 0°C *2 13.2max
	TEMPERATURE REGULATION[V]	0 to +40°C 2.5max -10 to 40°C 3.2max
	DRIFT[V]	*3 1.0max
	START-UP TIME[s]	1.0max (ACIN 200V, Io=100%)
	HOLD-UP TIME[ms]	ACIN 200V 10typ (Io=100%) 20typ (Io=50%)
	OUTPUT VOLTAGE ADJUSTMENT RANGE[V]	*4 180 - 350
	OUTPUT VOLTAGE SETTING[V]	250 - 253
PROTECTION CIRCUIT AND OTHERS	OVERCURRENT PROTECTION	Activate over 105% - 120% of rated current and recovers automatically. (Output voltage shuts down when the output voltage continuously drops due to overcurrent protection.) *5
	OVERVOLTAGE PROTECTION[V]	*5 400 - 450 (Active over 160%-180% of rated voltage.) *6
	DC_OK LAMP	LED (Green)
	ALARM LAMP	LED (Amber)
REMOTE ON/OFF	Provided	
ISOLATION	INPUT-OUTPUT · RC · WRN · PG	AC3,000V 1minute, Cutoff current = 25mA, DC500V 50MΩ min (At room temperature)
	INPUT-FG	AC2,000V 1minute, Cutoff current = 25mA, DC500V 50MΩ min (At room temperature)
	OUTPUT-FG	AC2,000V 1minute, Cutoff current = 25mA, DC500V 50MΩ min (At room temperature)
	RC · WRN · PG-FG	AC500V 1minute, Cutoff current = 100mA, DC500V 50MΩ min (At room temperature)
	OUTPUT-RC · WRN · PG	AC3,000V 1minute, Cutoff current = 25mA, DC500V 50MΩ min (At room temperature)
ENVIRONMENT	OPERATING TEMP., HUMID. AND ALTITUDE	-10 to +70°C (Refer to "Derating"), 20 - 90%RH (Non condensing), 3,000m (10,000 feet) max
	STORAGE TEMP., HUMID. AND ALTITUDE	-20 to +85°C, 20 - 90%RH (Non condensing), 9,000m (30,000 feet) max
	VIBRATION	10 - 55Hz, 19.6m/s ² (2G), 3minutes period, 60minutes each along X, Y and Z axis
	IMPACT	196.1m/s ² (20G), 11ms, once each along X, Y and Z axis
SAFETY AND NOISE REGULATIONS	AGENCY APPROVALS	UL62368-1, C-UL (CSA62368-1), EN62368-1
	CONDUCTED NOISE	Complies with FCC Part 15-A, CISPR32-A, EN55032-A, VCCI-A
	HARMONIC ATTENUATOR	Complies with IEC61000-3-2 Class A *7
OTHERS	CASE SIZE/WEIGHT	*8 102 X 41 X 340mm [4.02 X 1.61 X 13.39 inches] (W X H X D) / 2.3kg max
	COOLING METHOD	Forced cooling (internal fan)

*1 The current of input surge to a built-in noise filter (0.2ms or less) is excluded.

*2 Measured by 500MHz oscilloscope.
Ripple and ripple noise is measured on measuring board with capacitor of 2.2μF within 150mm from the output terminal.

*3 Drift is the change in DC output for an eight hour period after a half-hour warm-up at 25°C, with the input voltage held constant at the rated input/output.

*4 Can't be used above the rated output current and the rated output power.

*5 Output voltage recovers from protection by shutting down the input voltage and waiting more than 10 seconds then turning on AC input again, or turning off the output voltage by remote control.

*6 Since the voltage adjustment range is wide, the operating voltage of the overvoltage protection is set high.

*7 Please contact us about another class.

*8 Case size contains neither the terminal blocks, connector and screw.

* To meet the specifications, do not operate over-loaded condition.

* A sound may occur from power supply at peak loading.

Block diagram

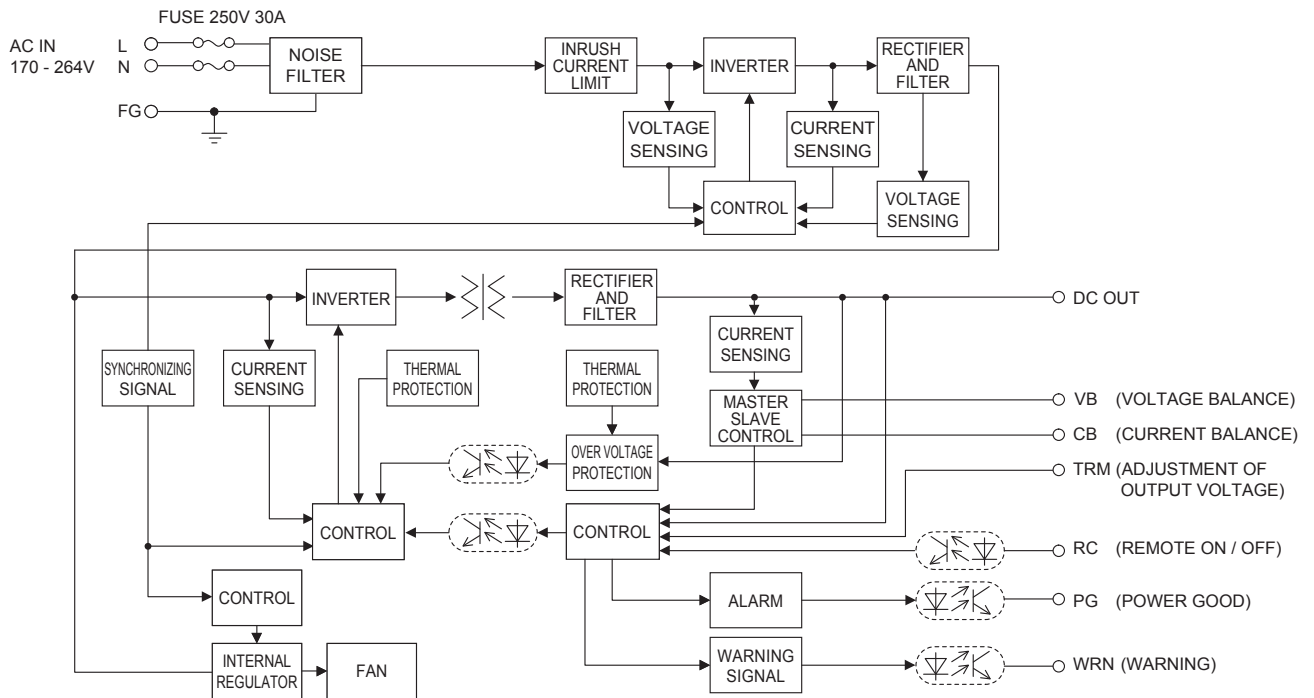

External view

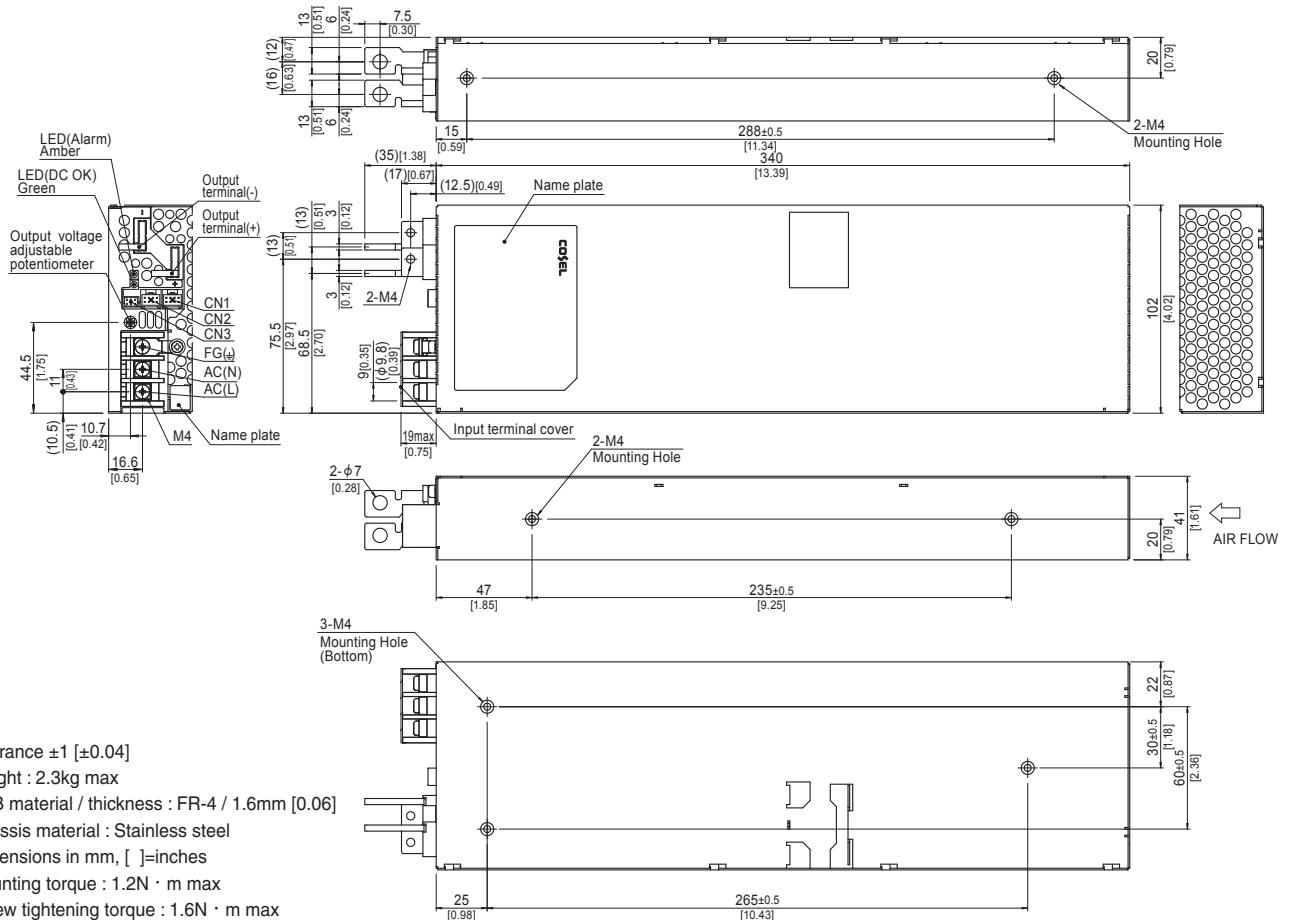

- * Tolerance ±1 [±0.04]
- * Weight : 2.3kg max
- * PCB material / thickness : FR-4 / 1.6mm [0.06]
- * Chassis material : Stainless steel
- * Dimensions in mm, []=inches
- * Mounting torque : 1.2N · m max
- * Screw tightening torque : 1.6N · m max
- * Please connect safety ground to FG terminal on the unit.

FETA7000T

FET A 7000 T -□□

① ② ③ ④ ⑤

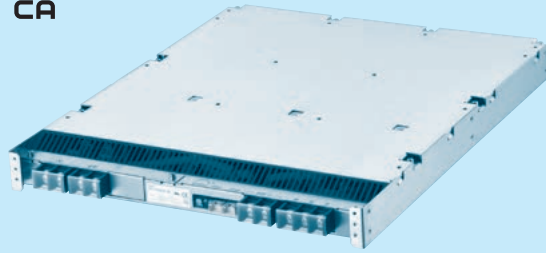

Example recommended EMI/EMC filter
TAC-30-683



*A higher current rating EMI/EMC filter may be recommended in view of the other devices that could be connected in parallel with the power supply.

- ① Series name
- ② Single output
- ③ Output wattage
- ④ Triple input phase
- ⑤ Output voltage

*Make sure necessary tests will be carried out on your end equipment with the power supply installed in accordance with any required EMC/EMI regulations.

MODEL	FETA7000T-48	FETA7000T-144
MAX OUTPUT WATTAGE[W]	*1 7113	7488
DC OUTPUT	48V 148.2A	144V 52A

SPECIFICATIONS

	MODEL	FETA7000T-48	FETA7000T-144	
INPUT	VOLTAGE[V]	AC170 - 264 3 φ (Output derating is required at AC170V - 180V. Refer to "Derating")		
	CURRENT[A]	ACIN 200V	22.7typ	
	FREQUENCY[Hz]		50 / 60 (47 - 63)	
	EFFICIENCY[%]	ACIN 230V	90.5% (Io=100%)	
	POWER FACTOR	ACIN 230V	0.98typ (Io=100%)	
	INRUSH CURRENT[A]	ACIN 200V *2	30max / 60max (Primary inrush current / Secondary inrush current) (More than 10 sec. to re-start)	
	LEAKAGE CURRENT[ma]		3.0max (ACIN 240V 60Hz, Io=100%, According to IEC62368-1)	
OUTPUT	VOLTAGE[V]	48	144	
	CURRENT[A]	ACIN 170V-180V ACIN 180V-264V	Output derating is required at ACIN 180V or less (refer to "Derating")	
	LINE REGULATION[mV]		192max	360max
	LOAD REGULATION[mV]		960max	1800max
	RIPPLE[mVp-p]	0 to +40°C *3	360max	720max
		-10 to 0°C *3	480max	960max
	RIPPLE NOISE[mVp-p]	0 to +40°C *3	480max	960max
		-10 to 0°C *3	600max	1200max
	TEMPERATURE REGULATION[mV]	0 to +40°C	480max	2200max
		-10 to +40°C	600max	2800max
	DRIFT[mV]	*4	192max	384max
	START-UP TIME[s]		1.7max (ACIN 200V, Io=100%)	
	HOLD-UP TIME[ms]	ACIN 200V	10typ (Io=100%)	20typ (Io=50%)
			20typ (Io=50%)	
OUTPUT VOLTAGE ADJUSTMENT RANGE[V] *5		28.8 - 52.8 *6	86.4 - 158.4 *7	
OUTPUT VOLTAGE SETTING[V]		47 - 49	141 - 147	
PROTECTION CIRCUIT AND OTHERS	OVERCURRENT PROTECTION	Works over 105% of rating (Recovers automatically, Hiccup overcurrent) (Output voltage shuts down when the output voltage continuously drops due to overcurrent protection.) *8		
	OVERVOLTAGE PROTECTION[V] *8	56 - 60	168 - 180	
	DC_OK LAMP	LED (Green)		
	ALARM LAMP	LED (Amber)		
REMOTE ON/OFF	Provided			
ISOLATION	INPUT-OUTPUT-AUX-RC-WRN-PG	AC3,000V 1minute, Cutoff current = 100mA, DC500V 50MΩ min (At room temperature)		
	INPUT-FG	AC2,000V 1minute, Cutoff current = 100mA, DC500V 50MΩ min (At room temperature)		
	OUTPUT-AUX-RC-WRN-PG-FG	AC500V 1minute, Cutoff current = 100mA, DC500V 50MΩ min (At room temperature)		
	OUTPUT-AUX-RC-WRN-PG	AC100V 1minute, Cutoff current = 100mA, DC100V 50MΩ min (At room temperature)		
ENVIRONMENT	OPERATING TEMP., HUMID. AND ALTITUDE	-10 to +60°C (Refer to "Derating"), 20 - 90%RH (Non condensing), 3,000m (10,000 feet) max		
	STORAGE TEMP., HUMID. AND ALTITUDE	-20 to +75°C, 20 - 90%RH (Non condensing), 9,000m (30,000 feet) max		
	VIBRATION	10 - 55Hz, 19.6m/s ² (2G), 3minutes period, 60minutes each along X, Y and Z axis		
	IMPACT	196.1m/s ² (20G), 11ms, once each along X, Y and Z axis		
SAFETY AND NOISE REGULATIONS	AGENCY APPROVALS	UL62368-1, C-UL (CSA62368-1), EN62368-1		
	CONDUCTED NOISE	Complies with FCC Part15-A, CISPR32-A, EN55032-A, VCCI-A		
	HARMONIC ATTENUATOR	Complies with IEC61000-3-12		
OTHERS	CASE SIZE/WEIGHT *9	388 X 43 X 475mm [15.28 X 1.69 X 18.70 inches] (W X H X D) / 11kg max		
	COOLING METHOD	Forced cooling (internal fan)		

- *1 AUX output power is not included.
- *2 The current of input surge to a built-in noise filter (0.2ms or less) is excluded.
- *3 Measured by 500MHz oscilloscope. Ripple and ripple noise is measured on measuring board with capacitor of 22μF within 150mm from the output terminal.
- *4 Drift is the change in DC output for an eight hour period after a half-hour warm-up at 25°C, with the input voltage held constant at the rated input/output.
- *5 Can't be used above the rated output current and the rated output power.
- *6 When the output voltage is adjusted to higher than 49.92V and the load factor is over 70% of the rated current, if the load current changes quickly (< 200msec), the output voltage drops approximately 5V below the setting voltage.
- *7 When the output voltage is adjusted to higher than 149.82V and the load factor is over 70% of the rated current, if the load current changes quickly (<200msec), the output voltage drops approximately 15V below the setting voltage.
- *8 Output voltage recovers from protection by shutting down the input voltage and waiting more than 10 seconds then turning on AC input again, or turning off the output voltage by remote control.
- *9 Case size contains neither the terminal blocks, connector and screw.
- * To meet the specifications, do not operate over-loaded condition.
- * A sound may occur from power supply at peak loading.

Block diagram

●FETA7000T-48

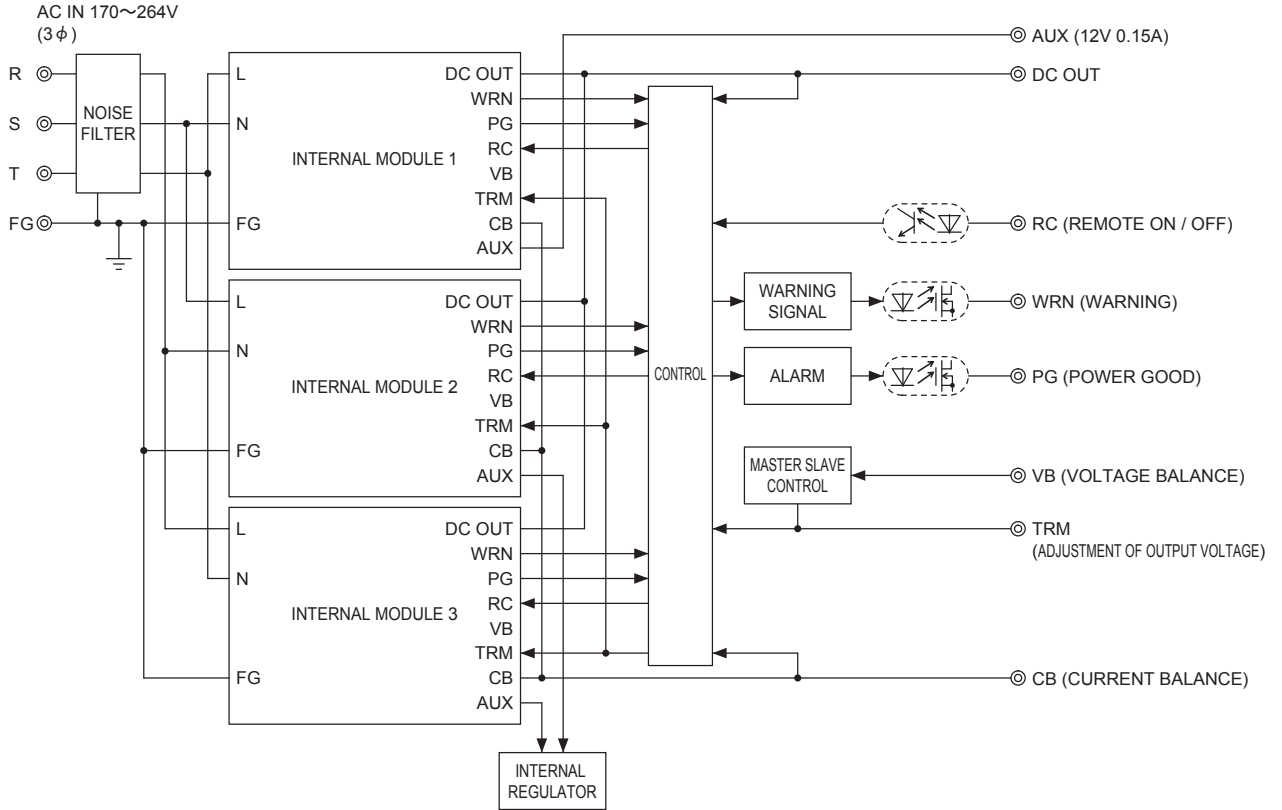

●FETA7000T-144

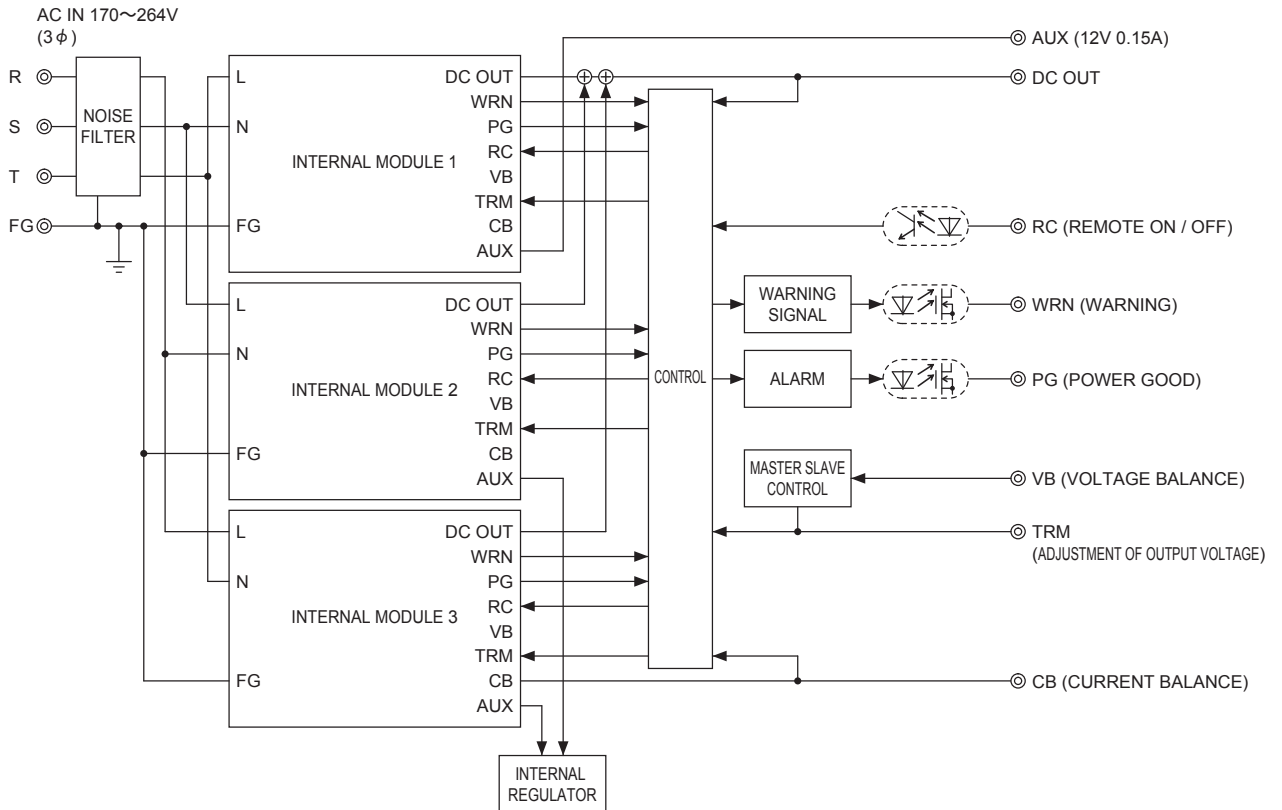

Block diagram of internal module

FETA

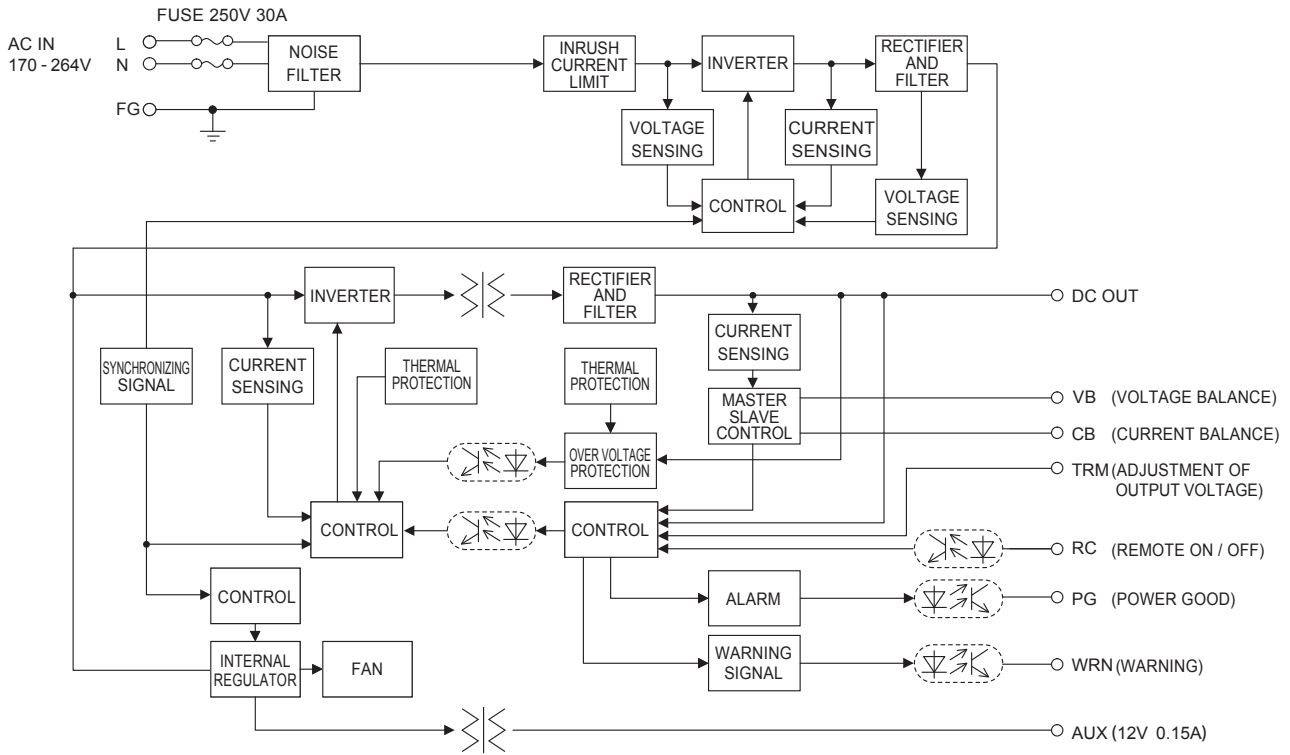

External view

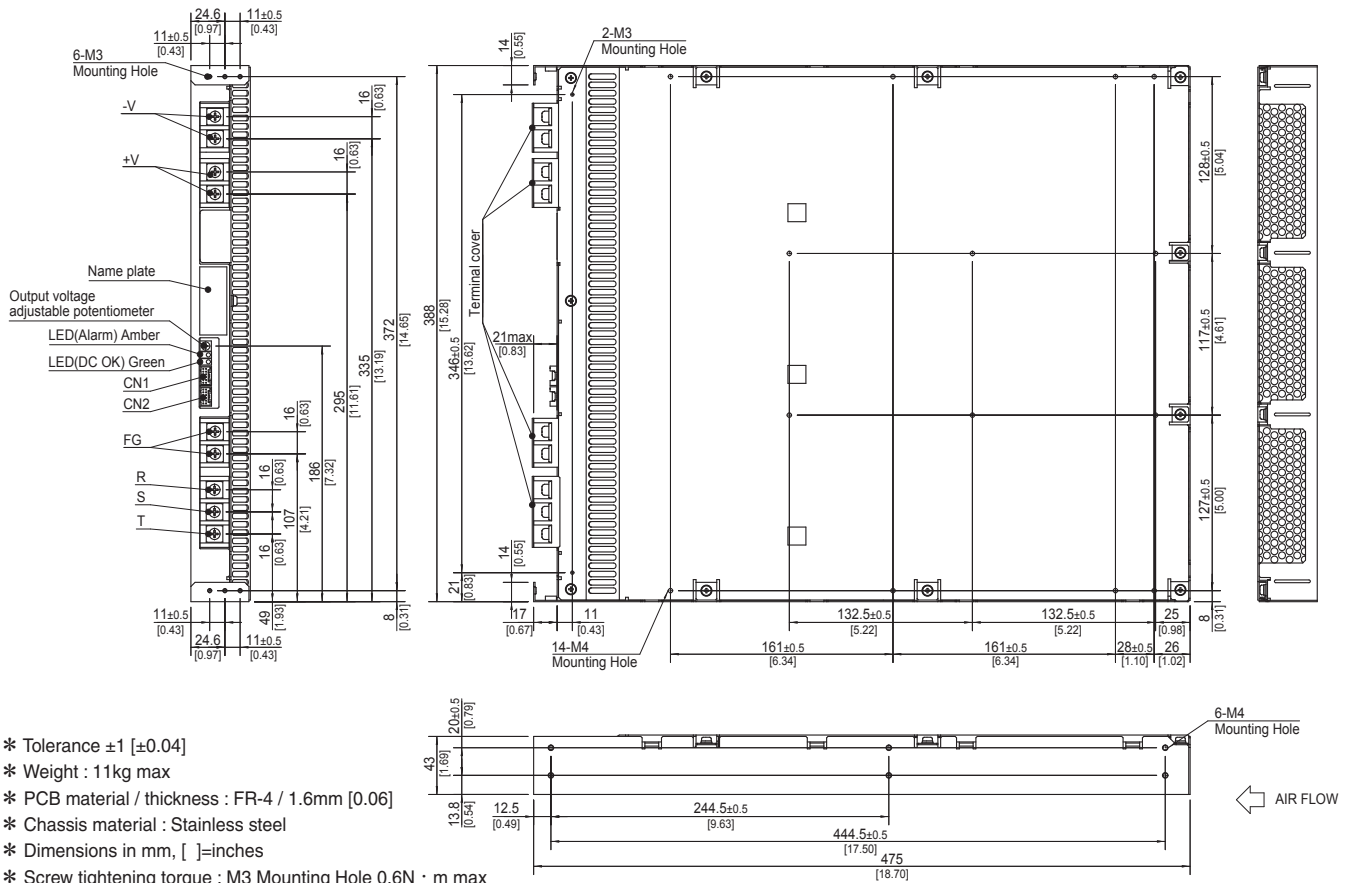

FETA

- * Tolerance ± 1 [± 0.04]
- * Weight : 11kg max
- * PCB material / thickness : FR-4 / 1.6mm [0.06]
- * Chassis material : Stainless steel
- * Dimensions in mm, []=inches
- * Screw tightening torque : M3 Mounting Hole 0.6N · m max
M4 Mounting Hole 1.2N · m max
M5 Input terminal 3.0N · m max
- * Please connect safety ground to FG terminal on the unit.

FETA7000ST

FET A 7000 ST -□□

① ② ③ ④ ⑤

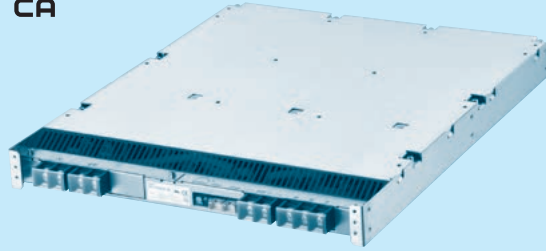

Example recommended EMI/EMC filter
YAC-25-685



*A higher current rating EMI/EMC filter may be recommended in view of the other devices that could be connected in parallel with the power supply.

- ① Series name
- ② Single output
- ③ Output wattage
- ④ 3 φ 4-Wire
- ⑤ Output voltage

*Make sure necessary tests will be carried out on your end equipment with the power supply installed in accordance with any required EMC/EMI regulations.

MODEL	FETA7000ST-48	FETA7000ST-144
MAX OUTPUT WATTAGE[W]	*1 7113	7488
DC OUTPUT	48V 148.2A	144V 52A

SPECIFICATIONS

	MODEL	FETA7000ST-48	FETA7000ST-144	
INPUT	VOLTAGE[V]	AC300 - 480 3 φ 4-Wire (Output derating is required at AC300V - 320V. Refer to "Derating")		
	CURRENT[A]	ACIN 400V *2	11.4typ	12.0typ
	FREQUENCY[Hz]	50 / 60 (47 - 63)		
	EFFICIENCY[%]	ACIN 400V	90.5% (Io=100%)	90.5% (Io=100%)
	POWER FACTOR	ACIN 400V	0.98typ (Io=100%)	
	INRUSH CURRENT[A]	ACIN 400V *3	40max / 80max (Primary inrush current / Secondary inrush current) (More than 10 sec. to re-start)	
OUTPUT	LEAKAGE CURRENT[mA]	5.0max (ACIN 480V 60Hz, Io=100%, According to IEC62368-1)		
	VOLTAGE[V]		48	144
	CURRENT[A]	ACIN 300V-320V ACIN 320V-480V	Output derating is required at ACIN 320V or less (refer to "Derating")	
	LINE REGULATION[mV]		192max	360max
	LOAD REGULATION[mV]		960max	1800max
	RIPPLE[mVp-p]	0 to +40°C *4	360max	720max
		-10 to 0°C *4	480max	960max
	RIPPLE NOISE[mVp-p]	0 to +40°C *4	480max	960max
		-10 to 0°C *4	600max	1200max
	TEMPERATURE REGULATION[mV]	0 to +40°C	480max	2200max
		-10 to +40°C	600max	2800max
	DRIFT[mV]	*5	192max	384max
	START-UP TIME[s]		1.7max (ACIN 400V, Io=100%)	
HOLD-UP TIME[ms]	ACIN 400V	10typ (Io=100%)		
		20typ (Io=50%)		
OUTPUT VOLTAGE ADJUSTMENT RANGE[V] *6		28.8 - 52.8 *7	86.4 - 158.4 *8	
OUTPUT VOLTAGE SETTING[V]		47 - 49	141 - 147	
PROTECTION CIRCUIT AND OTHERS	OVERCURRENT PROTECTION	Works over 105% of rating (Recovers automatically, Hiccup overcurrent) (Output voltage shuts down when the output voltage continuously drops due to overcurrent protection.) *9		
	OVERVOLTAGE PROTECTION[V] *9	56 - 60	168 - 180	
	DC_OK LAMP	LED (Green)		
	ALARM LAMP	LED (Amber)		
REMOTE ON/OFF	Provided			
ISOLATION	INPUT-OUTPUT-AUX-RC-WRN-PG	AC3,000V 1minute, Cutoff current = 100mA, DC500V 50MΩ min (At room temperature)		
	INPUT-FG	AC2,000V 1minute, Cutoff current = 100mA, DC500V 50MΩ min (At room temperature)		
	OUTPUT-AUX-RC-WRN-PG-FG	AC500V 1minute, Cutoff current = 100mA, DC500V 50MΩ min (At room temperature)		
	OUTPUT-AUX-RC-WRN-PG	AC100V 1minute, Cutoff current = 100mA, DC100V 50MΩ min (At room temperature)		
ENVIRONMENT	OPERATING TEMP., HUMID. AND ALTITUDE	-10 to +60°C (Refer to "Derating"), 20 - 90%RH (Non condensing), 3,000m (10,000 feet) max		
	STORAGE TEMP., HUMID. AND ALTITUDE	-20 to +75°C, 20 - 90%RH (Non condensing), 9,000m (30,000 feet) max		
	VIBRATION	10 - 55Hz, 19.6m/s ² (2G), 3minutes period, 60minutes each along X, Y and Z axis		
SAFETY AND NOISE REGULATIONS	IMPACT	196.1m/s ² (20G), 11ms, once each along X, Y and Z axis		
	AGENCY APPROVALS	UL62368-1, C-UL (CSA62368-1), EN62368-1		
	CONDUCTED NOISE	Complies with FCC Part15-A, CISPR32-A, EN55032-A, VCCI-A with an external EMI/EMC filter. (refer to Instruction manual)		
OTHERS	HARMONIC ATTENUATOR	Complies with IEC61000-3-2 Class A *10		
	CASE SIZE/WEIGHT *11	388 X 43 X 475mm [15.28 X 1.69 X 18.70 inches] (W X H X D) / 11kg max		
	COOLING METHOD	Forced cooling (internal fan)		

- *1 AUX output power is not included.
- *2 The current flowing through the neutral line increases when AC input voltage is over AC456V 3 φ 4-Wire. The flowing current will vary according to the input voltage and the load current. The maximum flowing current will be 18A.
- *3 The current of input surge to a built-in noise filter (0.2ms or less) is excluded.
- *4 Measured by 500MHz oscilloscope. Ripple and ripple noise is measured on measuring board with capacitor of 22μF within 150mm from the output terminal.
- *5 Drift is the change in DC output for an eight hour period after a half-hour warm-up at 25°C, with the input voltage held constant at the rated input/output.
- *6 Can't be used above the rated output current and the rated output power.
- *7 When the output voltage is adjusted to higher than 49.92V and the load factor is over 70% of the rated current, if the load current changes quickly (< 200msec), the output voltage drops approximately 5V below the setting voltage.
- *8 When the output voltage is adjusted to higher than 149.82V and the load factor is over 70% of the rated current, if the load current changes quickly (< 200msec), the output voltage drops approximately 15V below the setting voltage.
- *9 Output voltage recovers from protection by shutting down the input voltage and waiting more than 10 seconds then turning on AC input again, or turning off the output voltage by remote control.
- *10 Please contact us about another class.
- *11 Case size contains neither the terminal blocks, connector and screw. To meet the specifications, do not operate over-loaded condition. A sound may occur from power supply at peak loading.

Block diagram

●FETA7000ST-48

AC IN 300~480V (3 φ 4-Wire)

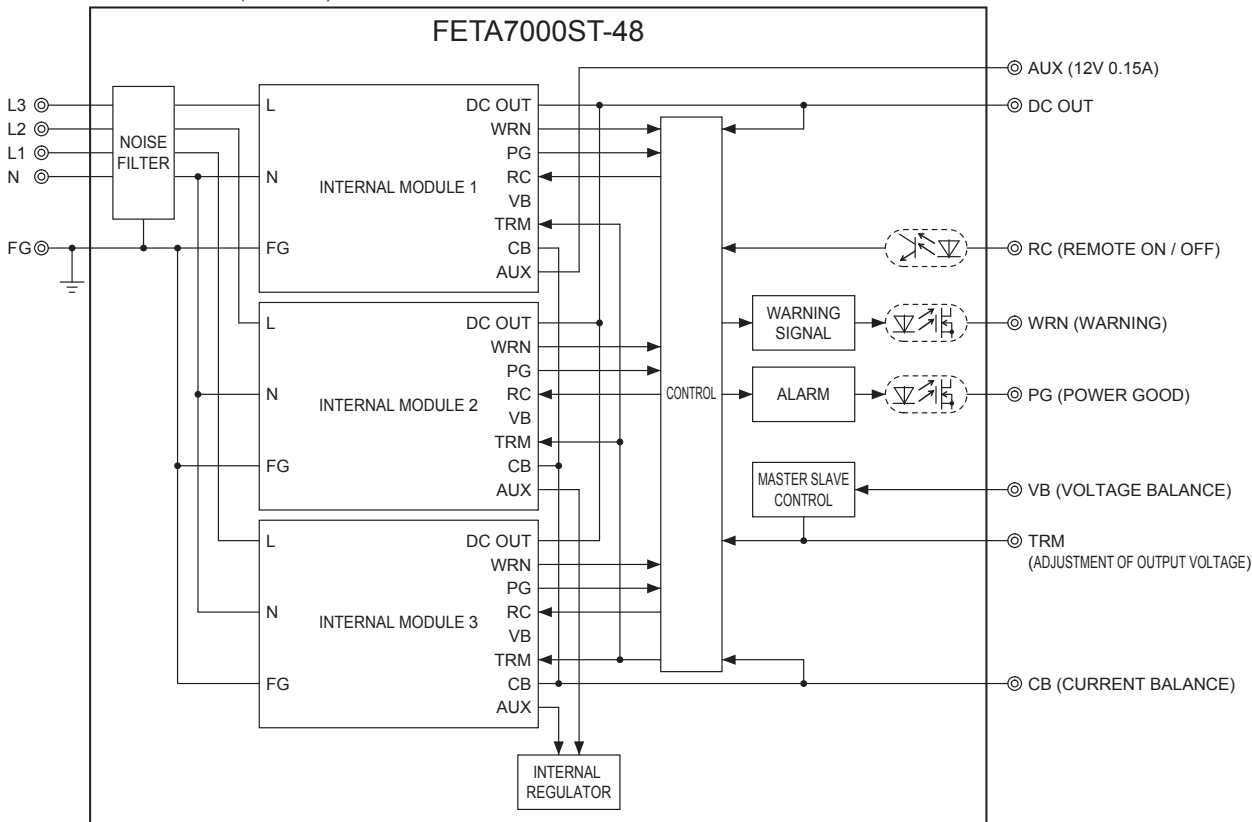

●FETA7000ST-144

AC IN 300~480V (3 φ 4-Wire)

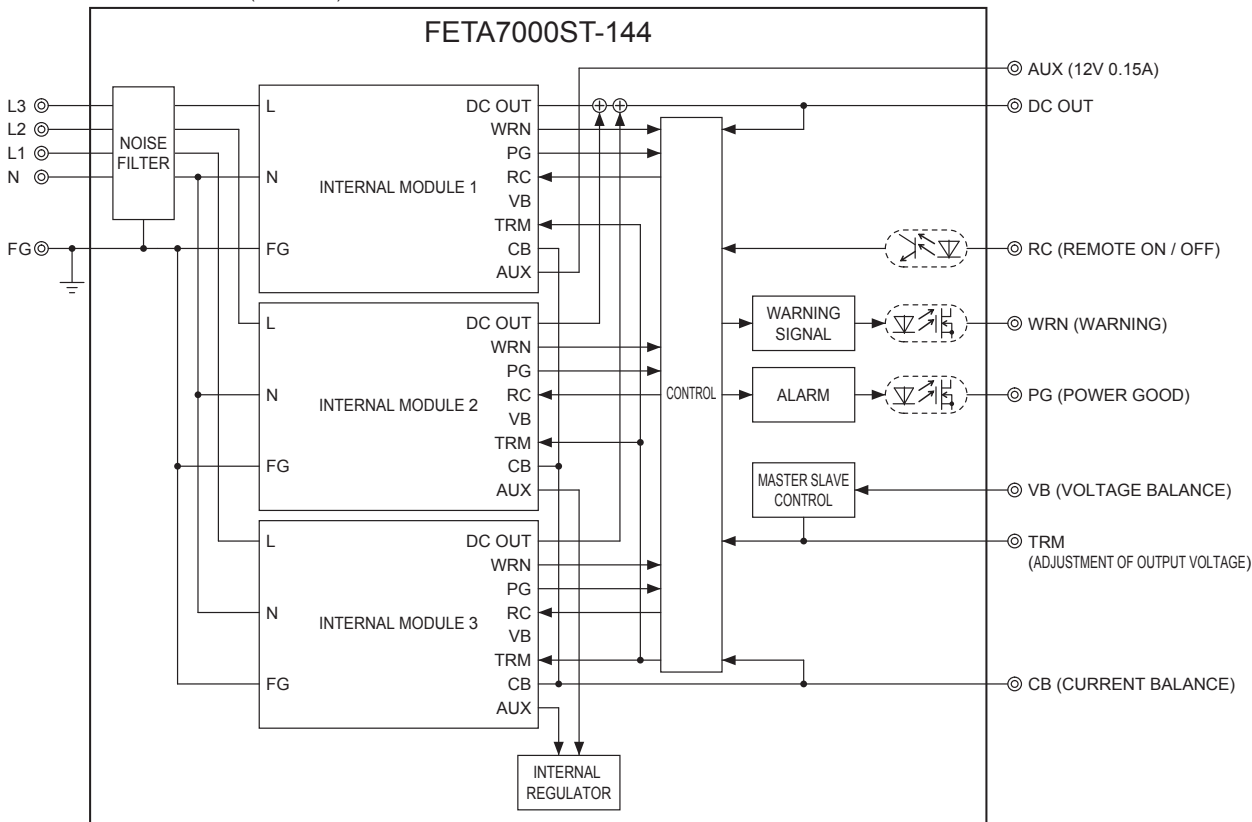

Block diagram of internal module

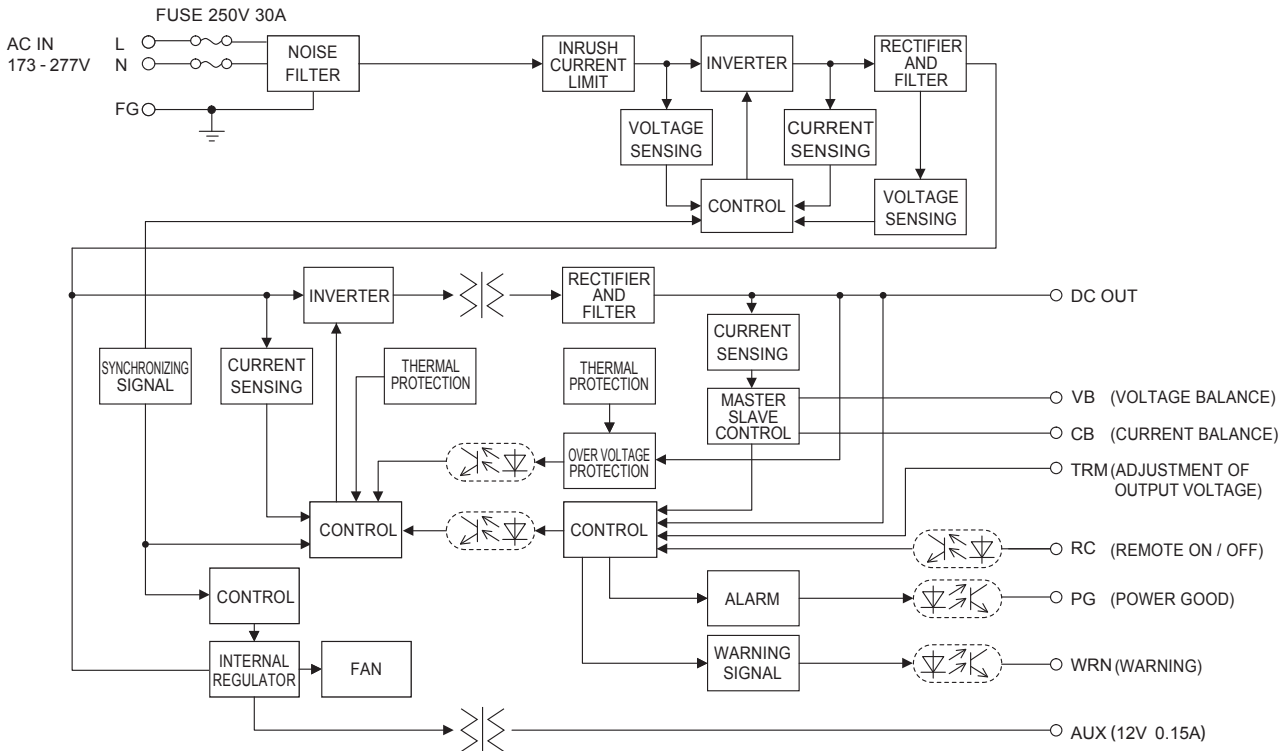

External view

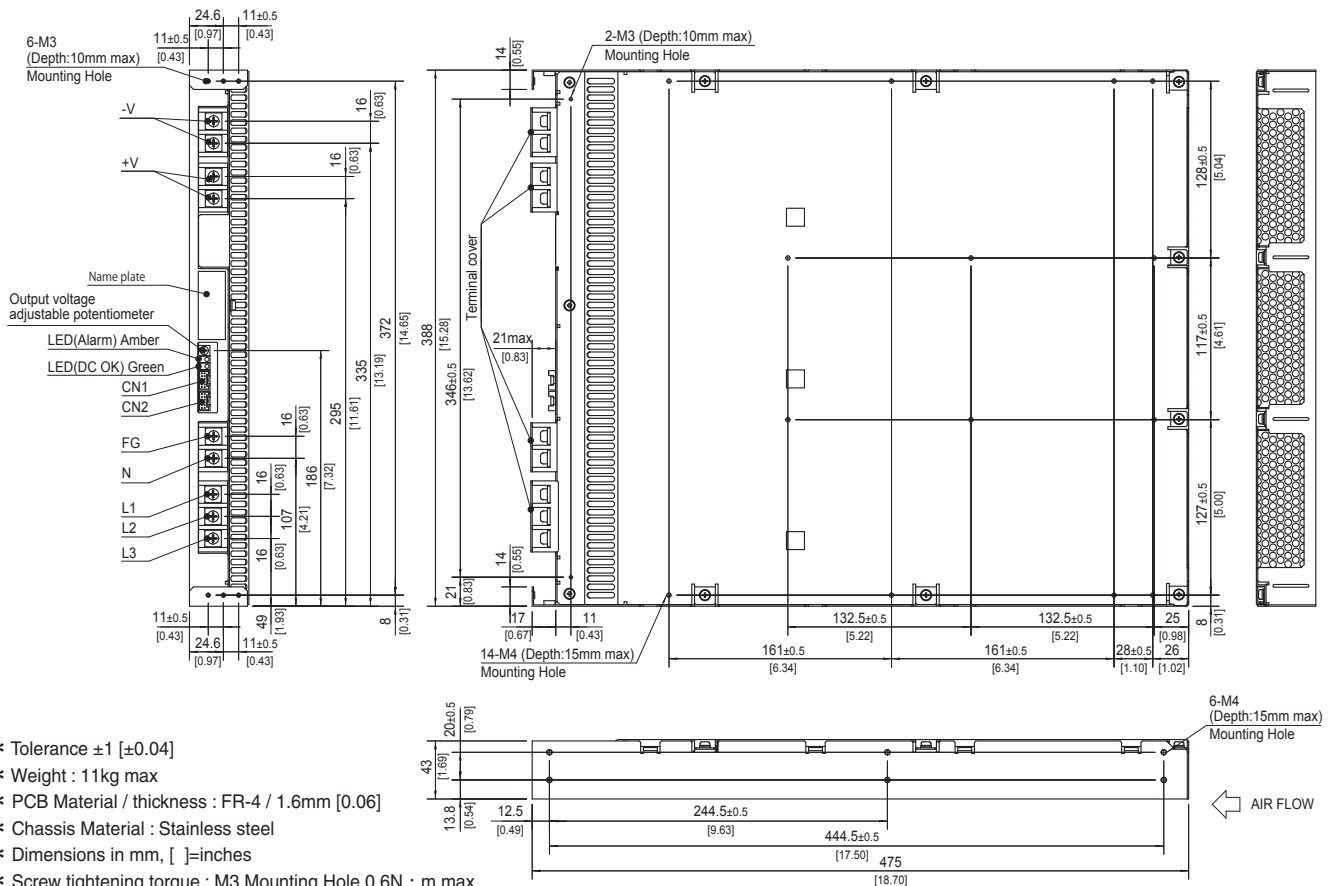

- * Tolerance ± 1 [± 0.04]
- * Weight : 11kg max
- * PCB Material / thickness : FR-4 / 1.6mm [0.06]
- * Chassis Material : Stainless steel
- * Dimensions in mm, []=inches
- * Screw tightening torque : M3 Mounting Hole 0.6N · m max
M4 Mounting Hole 1.2N · m max
M5 Terminal block 3.0N · m max
- * Please connect safety ground to FG terminal on the unit.

Terminal Blocks

FETA2500BA, 3000BA

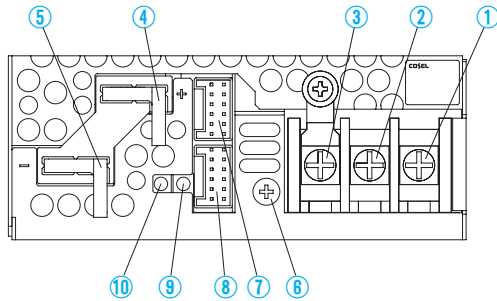

- ①AC (L) } Input Terminals AC170 - 264V 1 φ 47 - 63Hz
- ②AC (N) } (M4)
- ③Frame ground (M4 \perp)
- ④+Output
- ⑤-Output
- ⑥Output voltage adjustable potentiometer
- ⑦CN1 } Connectors
- ⑧CN2 }
- ⑨LED for output voltage confirmation (DC_OK)
- ⑩LED for fault condition detection (ALARM)

FETA3000BC

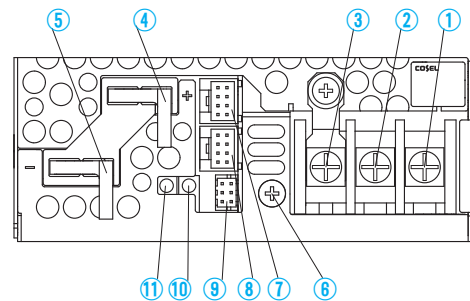

- ①AC (L) } Input Terminals AC170 - 264V 1 φ 47 - 63Hz
- ②AC (N) } (M4)
- ③Frame ground (M4 \perp)
- ④+Output
- ⑤-Output
- ⑥Output voltage adjustable potentiometer
- ⑦CN1 } Connectors
- ⑧CN2 }
- ⑨CN3 }
- ⑩LED for output voltage confirmation (DC_OK)
- ⑪LED for fault condition detection (ALARM)

FETA2500BA, 3000BA

Pin Configuration and Functions of CN1, CN2

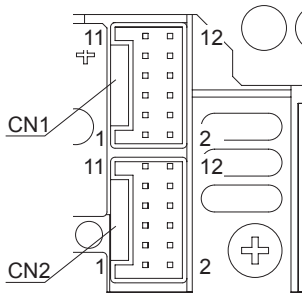

Pin Configuration and Function of CN1, CN2

Pin No.	Pin Name	Function
1	AUXG	Auxiliary power output (GND)
2	AUX	Auxiliary power output
3	WRNG	Warning signal (GND)
4	WRN	Warning signal
5	PGG	Alarm signal (GND)
6	PG	Alarm signal
7	RCG	Remote ON/OFF (GND)
8	RC	Remote ON/OFF
9	COM	Signal ground
10	TRM	Adjustment of output voltage
11	VB	Voltage Balance
12	CB	Current Balance

Mating connector and terminal

Connector	Housing	Terminal	Mfr.
CN1 CN2	S12B-PUDSS-1 PUDP-12V-S	Reel : SPUD-001T-P0.5 or SPUD-002T-P0.5	J.S.T

FETA3000BC

Pin Configuration and Function of CN1, CN2, CN3

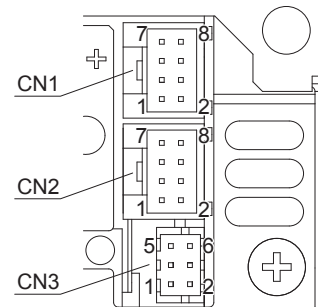

Pin Configuration and Functions of CN1, CN2

Pin No.	Pin Name	Function
1	N.C.	-
2	N.C.	-
3	N.C.	-
4	N.C.	-
5	COM	Signal ground
6	TRM	Adjustment of output voltage
7	VB	Voltage Balance
8	CB	Current Balance

Pin Configuration and Functions of CN3

Pin No.	Pin Name	Function
1	WRNG	Warning signal (GND)
2	WRN	Warning signal
3	PGG	Alarm signal (GND)
4	PG	Alarm signal
5	RCG	Remote ON/OFF (GND)
6	RC	Remote ON/OFF

Mating connector and terminal

Connector	Housing	Terminal	Mfr.
CN1 CN2	S8B-PUDSS-1 PUDP-8V-S	Reel : SPUD-001T-P0.5 or SPUD-002T-P0.5	J.S.T
CN3	DF11-6DP-2DS DF11-6DS-2C	DF11-22SCF or DF11-2428SCF	Hirose

Terminal Blocks

FETA7000T

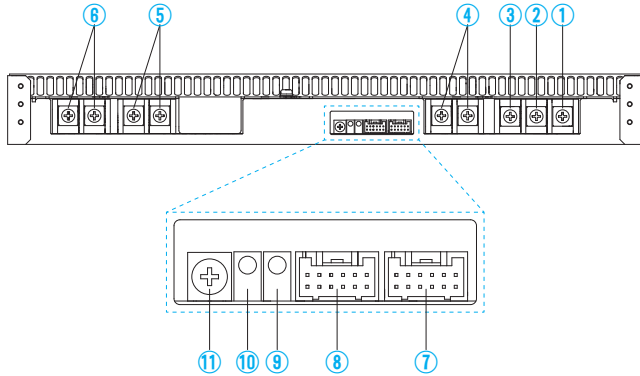

- ①AC (T) } Input Terminals AC170 - 264V 3 φ 47 - 63Hz
- ②AC (S) } (M5)
- ③AC (R) }
- ④Frame ground (M5 ≍)
- ⑤+Output
- ⑥-Output
- ⑦CN2 } Connectors
- ⑧CN1 }
- ⑨LED for output voltage confirmation (DC_OK)
- ⑩LED for fault condition detection (ALARM)
- ⑪Output voltage adjustable potentiometer

FETA7000ST

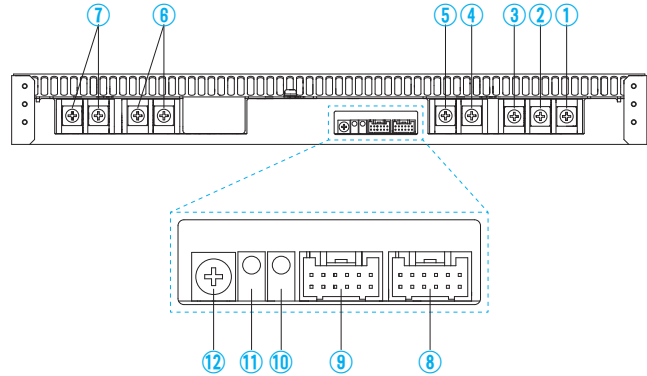

- ①AC (L3) } Input Terminals AC170 - 264V 3 φ - 4 wire 47 - 63Hz
- ②AC (L2) }
- ③AC (L1) } (M5)
- ④AC (N) }
- ⑤Frame ground (M5 ≍)
- ⑥+Output
- ⑦-Output
- ⑧CN2 } Connectors
- ⑨CN1 }
- ⑩LED for output voltage confirmation (DC_OK)
- ⑪LED for fault condition detection (ALARM)
- ⑫Output voltage adjustable potentiometer

FETA7000T

Pin Configuration and Functions of CN1, CN2

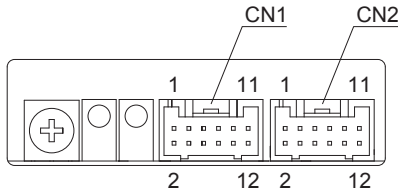

Pin Configuration and Function of CN1, CN2

Pin No.	Pin Name	Function
1	AUXG	Auxiliary power output (GND)
2	AUX	Auxiliary power output
3	WRNG	Warning signal (GND)
4	WRN	Warning signal
5	PGG	Alarm signal (GND)
6	PG	Alarm signal
7	RCG	Remote ON/OFF (GND)
8	RC	Remote ON/OFF
9	COM	Signal ground
10	TRM	Adjustment of output voltage
11	VB	Voltage Balance
12	CB	Current Balance

Mating connector and terminal

Connector	Housing	Terminal	Mfr.
CN1 CN2	S12B-PUDSS-1 PUDP-12V-S	Reel : SPUD-001T-P0.5 or SPUD-002T-P0.5	J.S.T

FETA7000ST

Pin Configuration and Functions of CN1, CN2

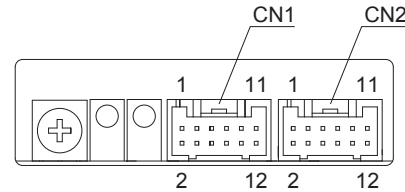

Pin Configuration and Function of CN1, CN2

Pin No.	Pin Name	Function
1	AUXG	Auxiliary power output (GND)
2	AUX	Auxiliary power output
3	WRNG	Warning signal (GND)
4	WRN	Warning signal
5	PGG	Alarm signal (GND)
6	PG	Alarm signal
7	RCG	Remote ON/OFF (GND)
8	RC	Remote ON/OFF
9	COM	Signal ground
10	TRM	Adjustment of output voltage
11	VB	Voltage Balance
12	CB	Current Balance

Mating connector and terminal

Connector	Housing	Terminal	Mfr.
CN1 CN2	S12B-PUDSS-1 PUDP-12V-S	Reel : SPUD-001T-P0.5 or SPUD-002T-P0.5	J.S.T

Assembling and Installation Method

Installation Method

- Screw mounting requires considering the product weight for safety fixtures.
- To keep enough insulation distance between screws and internal components, length of the mounting screw should not exceed recommendation as shown in right figure.

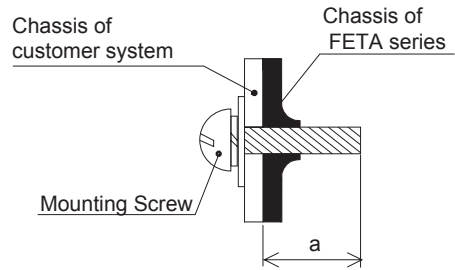

Model	Mounting hole	a (Max penetration length)
FETA2500BA, 3000BA, 3000BC	Bottom	6mm max
	Side	4.5mm max
FETA7000T, 7000ST	Side	15mm max

- The power supplies have a built-in forced cooling fan. Do not block ventilation at the suction side and its opposite side.
- * Reverse airflow option (-F2) is available for FETA2500BA. Refer to Instruction manual.
- If you use a power supply in a dusty environment, it can cause a failure. Please consider taking such countermeasures as installing an air filter near the suction area of the system to prevent a failure.

FETA2500BA, 3000BA, 3000BC

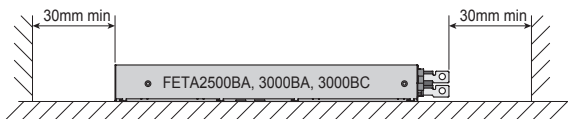
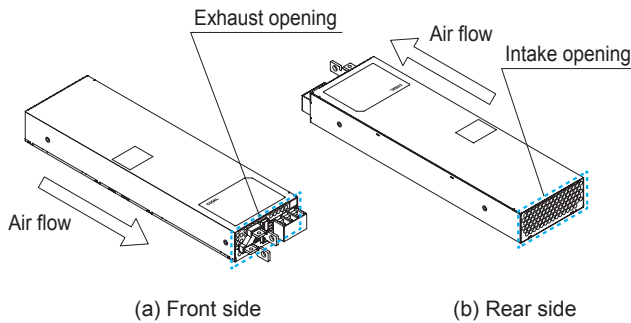

FETA7000T, 7000ST

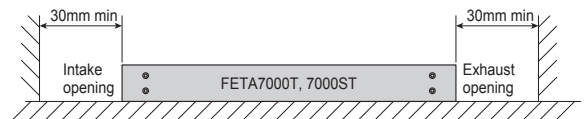
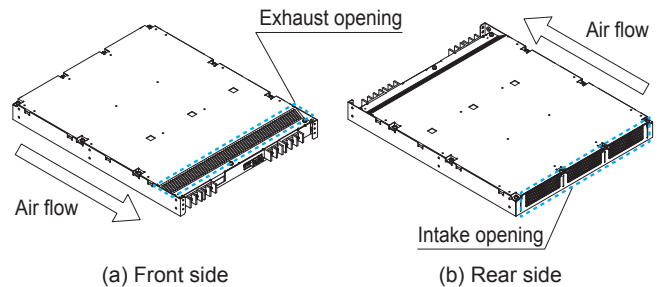

- When mounting the power supply with screws, it is recommended that this be done as shown below. If other methods are used, be sure the weight of the power supply is taken into account.

FETA2500BA, 3000BA, 3000BC

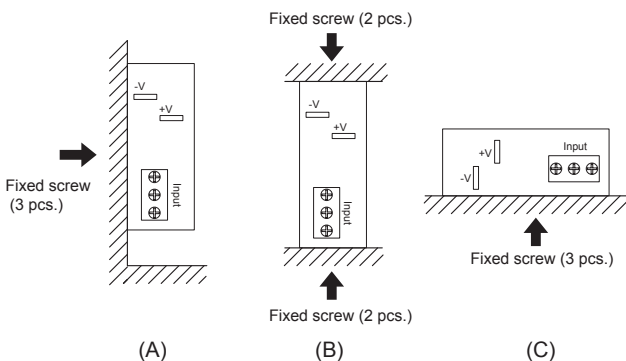

FETA7000T, 7000ST

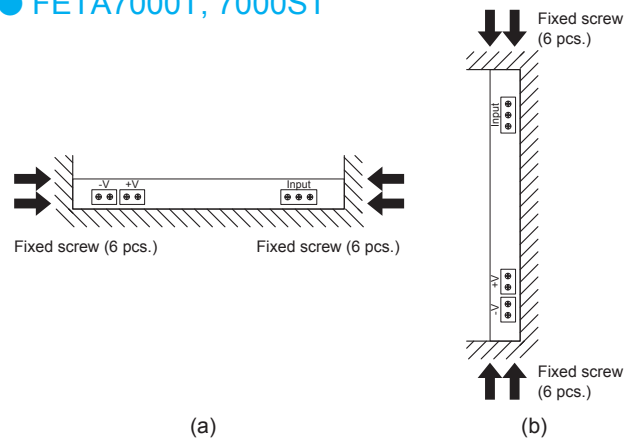

Derating

● Input Voltage Derating Curve

FETA2500BA, 3000BA, 3000BC, 7000T

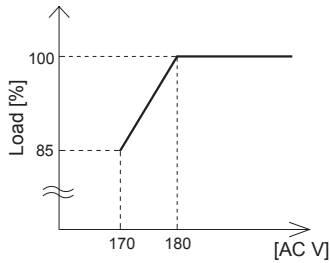

FETA7000ST

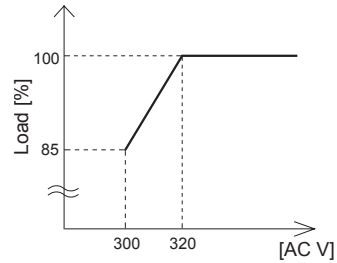

FETA

● Ambient Temperature Derating Curve

FETA2500BA, FETA3000BA

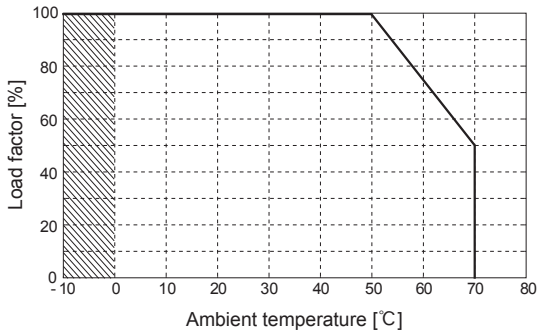

FETA3000BC

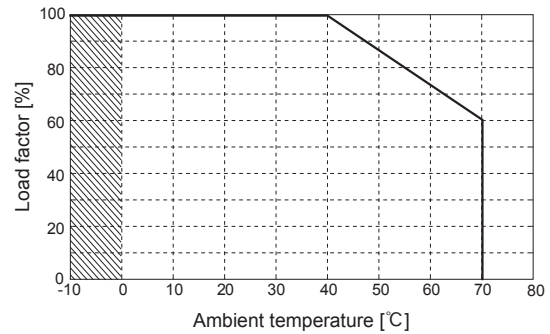

FETA7000T, FETA7000ST

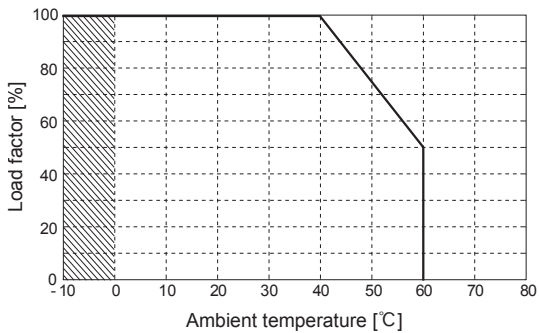

■ Specifications for ripple and ripple noise changes in the shaded area.

Instruction Manual

◆ It is necessary to read the "Instruction Manual" and "Before using our product" before you use our product.

Instruction Manual <https://www.cosel.co.jp/redirect/catalog/en/FETA/>
 Before using our product <https://en.cosel.co.jp/technical/caution/index.html>

FETA



NOTICE



Basic Characteristics Data

FETA

Model	Circuit method	Switching frequency [kHz]	Input current [A]	Rated input fuse	Inrush current protection circuit	PCB/Pattern			Series/Parallel operation availability	
						Material	Single sided	Double sided	Series operation	Parallel operation
FETA2500BA	Active filter	47	13.8	250V 30A	Relay	FR-4		Yes	Yes	Yes
	Phase-shift Full-bridge converter	94								
FETA3000BA	Active filter	47	16.6	250V 30A	Relay	FR-4		Yes	Yes	Yes
	Phase-shift Full-bridge converter	94								
FETA3000BC	Active filter	47	16.8	250V 30A	Relay	FR-4		Yes		Yes
	Phase-shift Full-bridge converter	94								
FETA7000T	Active filter	47	23.9	250V 30A	Relay	FR-4		Yes	Yes	Yes
	Phase-shift Full-bridge converter	94								

* The value of input current is at ACIN 200V and rated load.

Model	Circuit method	Switching frequency [kHz]	Input current [A]	Rated input fuse	Inrush current protection circuit	PCB/Pattern			Series/Parallel operation availability	
						Material	Single sided	Double sided	Series operation	Parallel operation
FETA7000ST	Active filter	47	12.0	250V 30A	Relay	FR-4		Yes	Yes	Yes
	Phase-shift Full-bridge converter	94								

* The value of input current is at ACIN 400V and rated load.



SC-series

DC48V Front end power supply

SC

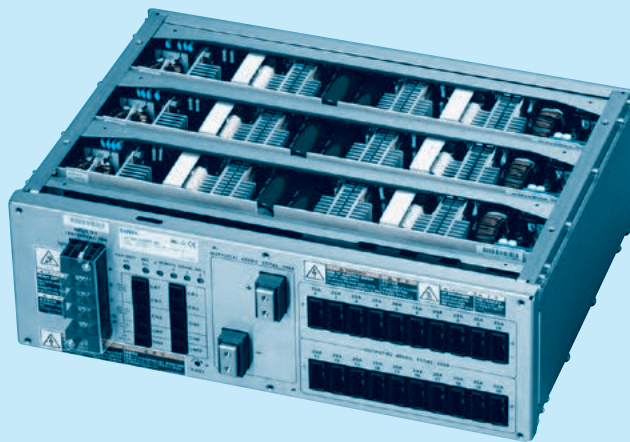

SCHA10000T



SCDA10000T

Feature

- High power, AC-DC front end power supply
- Three-phase input(AC160 - 264V 3 φ)
- High efficiency (90%), High power factor (0.99)
- Harmonic attenuator (Complies with IEC61000-3-12)
- Complies with SEMI F47
- Wide output voltage adjustable range approximately 0 to 52.8V (Optional)
- Constant current regulation provided with additional external components (Optional)
- Parallel operation and Parallel redundancy operation (SCHA10000T)
- System ON / OFF (Remote ON / OFF)
- Alarms
- Output Voltage Monitor
- Parallel Control (Start in / out)
- Remote Signal ON / OFF

Safety agency approvals

UL60950-1, C-UL, EN62368-1

3-year warranty

CE marking

Low Voltage Directive
RoHS Directive

UKCA marking

Electrical Equipment Safety Regulations
RoHS Regulations

EMI

Complies with EN55011 Group1-A, EN55022-A, CISPR22-A, FCC Part15 classA

EMS Compliance : EN61204-3, EN61000-6-2

EN61000-4-2
EN61000-4-3
EN61000-4-4
EN61000-4-5
EN61000-4-6
EN61000-4-8
EN61000-4-11

SCHA 10000T/SCDA 10000T

SC H A 10000 T -48 -□

① ② ③ ④ ⑤ ⑥ ⑦



SCHA10000T

SCDA10000T

Example recommended EMI/EMC filter
Filter TAC-50-223

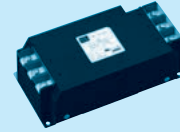

*A higher current rating EMI/EMC filter may be recommended in view of the other devices that could be connected in parallel with the power supply.

- ① Series name
- ② External form
H:Wide front interface
D:Compact front interface
- ③ Single output
- ④ Output wattage
- ⑤ Three-phase input
- ⑥ Output voltage
- ⑦ Optional

*Make sure necessary tests will be carried out on your end equipment with the power supply installed in accordance with any required EMC/EMI regulations.

SPECIFICATIONS

	MODEL	SCHA10000T-48	SCDA10000T-48	
INPUT	VOLTAGE[V]	AC160 - 264 3 φ		
	CURRENT[A]	ACIN200V	35typ	
	FREQUENCY[Hz]	50/60 (47 - 63)		
	EFFICIENCY[%]	ACIN200-240V	90typ	
	POWER FACTOR	ACIN200-240V	0.99typ (Io=100%)	
	INRUSH CURRENT[A]	ACIN240V *1	60typ / 80typ (Primary inrush current /Secondary inrush current) (More than 3 sec. to re-start)	
	LEAKAGE CURRENT[mA]	5.0max (ACIN 240V 60Hz, Io=0 - 100%, According to IEC62368-1)		
OUTPUT	VOLTAGE[V]	48		
	CURRENT[A]	208		
	WATTAGE[W]	9,984		
	LINE REGULATION[mV]	192max		
	LOAD REGULATION[mV]	720max		
	RIPPLE[mVp-p]	0 to +50°C *2	150max	
	RIPPLE NOISE[mVp-p]	0 to +50°C *2	200max (BW:500MHz)	
	TEMPERATURE REGULATION[mV]	0 to +50°C	240max	
	DRIFT[mV]	*3	192max	
	START-UP TIME[ms]	*6	750max (ACIN 200V, Io=100%)	
	HOLD-UP TIME[ms]	20typ (ACIN200V, Io=100%)		
OUTPUT VOLTAGE ADJUSTMENT RANGE[V]	43.2 - 52.8			
OUTPUT VOLTAGE SETTING[V]	47.0 - 49.0			
PROTECTION CIRCUIT AND OTHERS	OVERCURRENT PROTECTION	Activate over 105% - 120% of rated current and recovers automatically. (Shut down if low-voltage protection activated)		
	OVERVOLTAGE PROTECTION[V]	*4	56.0 - 59.0 (shut down)	
	LOW-VOLTAGE PROTECTION[V]	*4	28.8 - 33.6 (shut down)	
	OPERATING INDICATION	LED : Green (48VDC output), White (AC IN)		
	ALARM OUTPUT	Detecting low input voltage, detecting open phase, detecting low output voltage		
REMOTE ON/OFF (SYSTEM ON/OFF)	Provided			
ISOLATION	(INPUT) - (OUTPUT - SYSTEM ON/OFF - REMOTE SIGNAL ON/OFF - ALARM)	AC3,000V 1minute, Cutoff current = 100mA, DC2,200V 1minute, Cutoff current = 1mA (At Room Temperature) DC500V 50MΩ min (At Room Temperature)		
	(INPUT) - (FG)	AC2,000V 1minute, Cutoff current = 100mA, DC2,200V 1minute, Cutoff current = 1mA (At Room Temperature) DC500V 50MΩ min (At Room Temperature)		
	(OUTPUT - SYSTEM ON/OFF - REMOTE SIGNAL ON/OFF - ALARM) - (FG)	AC500V 1minute, Cutoff current = 100mA, DC500V 50MΩ min (At Room Temperature)		
	(OUTPUT) - (SYSTEM ON/OFF - REMOTE SIGNAL ON/OFF - ALARM)	AC100V 1minute, Cutoff current = 50mA, DC100V 10MΩ min (At Room Temperature)		
ENVIRONMENT	OPERATING TEMP., HUMID. AND ALTITUDE	0 to +50°C, 20 - 85%RH (Non condensing), 3,000m(10,000feet) max (Refer to Cooling method)		
	STORAGE TEMP., HUMID. AND ALTITUDE	-25 to +85°C, 20 - 90%RH (Non condensing), 9,000m(30,000feet) max		
	VIBRATION	10 - 55Hz, 19.6m/s ² (2G), 3minutes period, 30 minutes each along X, Y and Z axis		
	IMPACT	196.1m/s ² (20G), 11ms, once each along X, Y and Z axis		
SAFETY AND NOISE REGULATIONS	AGENCY APPROVALS	UL60950-1, C-UL (CSA60950-1), EN62368-1 complies		
	CONDUCTED NOISE	Complies with EN55011 Group1-A, EN55022-A, CISPR22-A, FCC part15 classA, additional EMI/EMC Filter required for meeting class B		
	HARMONIC ATTENUATOR	Complies with IEC61000-3-12		
OTHERS	CASE SIZE/WEIGHT *5	459 X 150 X 320mm [18.07 X 5.91 X 12.6 inches] (W X H X D)/23kg max	310.5 X 150 X 510mm [12.22 X 5.91 X 20.08 inches] (W X H X D)/20kg max	
	COOLING METHOD	Forced cooling (require external fan)		

*1 The current of input surge to a built-in noise filter (0.2ms or less) is excluded.

*2 Measured by 500MHz oscilloscope.

*3 Drift is the change in DC output for an eight hour period after a half-hour warm-up at 25°C, with the input voltage held constant at the rated input/output.

*4 To recover output voltage, recycle input voltage after 3 or more seconds.

*5 Case size contains neither the terminal blocks, connector and screw nor.

*6 When input voltage recycling is needed for output recovery, AC power shall be removed and cycled after 3 seconds to reset the protection circuit.

Please contact us when it's necessary to restart the power supply in less than 3 seconds.

SCHA/SCDA1000T Block diagram

● SCHA/SCDA1000T Block diagram

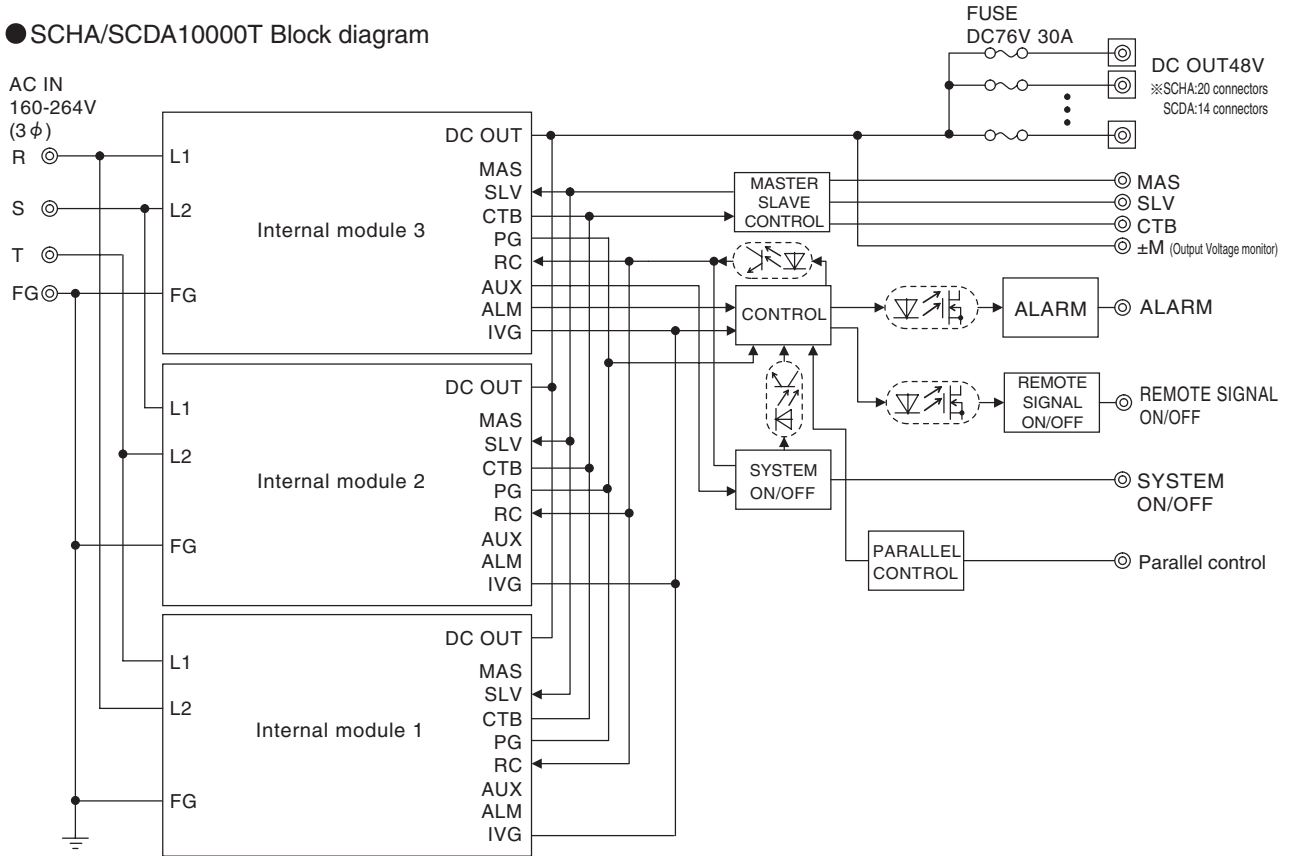

● Internal module Block diagram

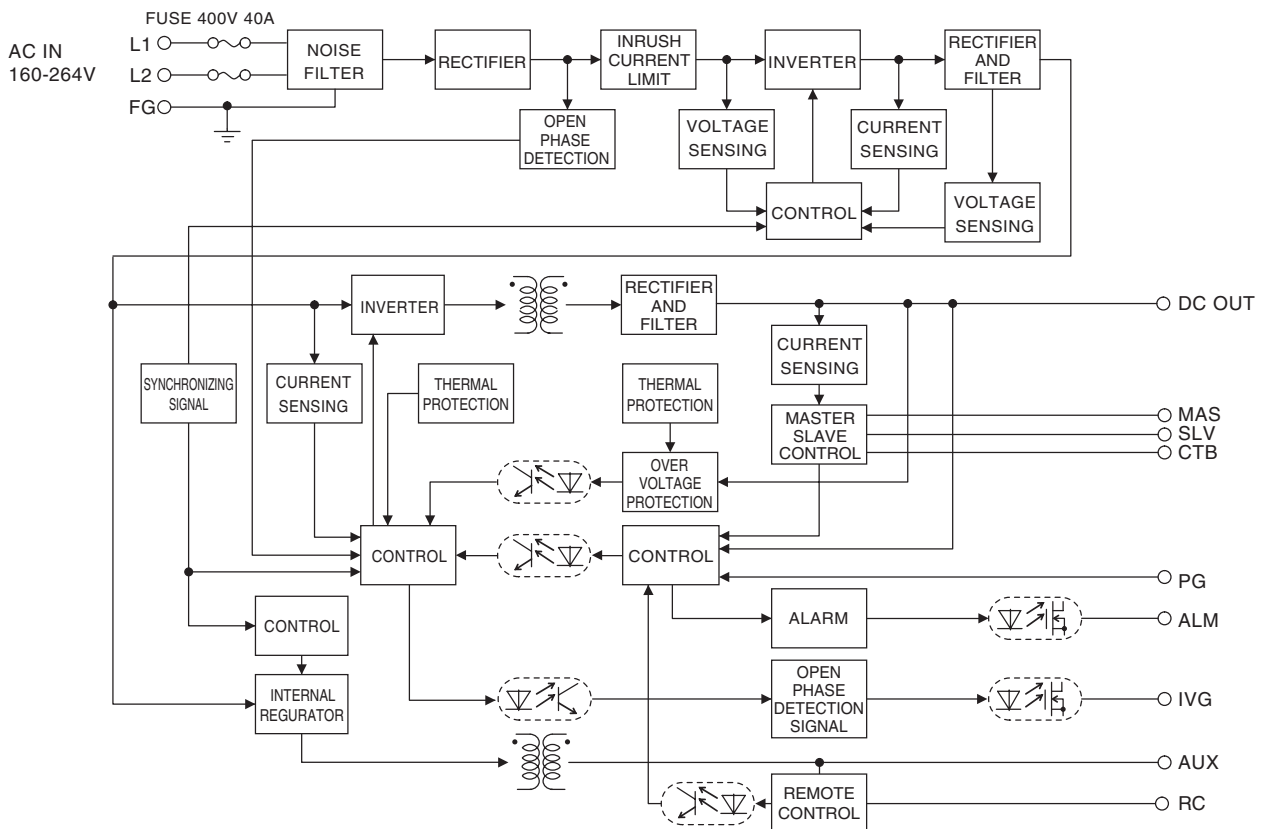

SCHA1000T external view

SC

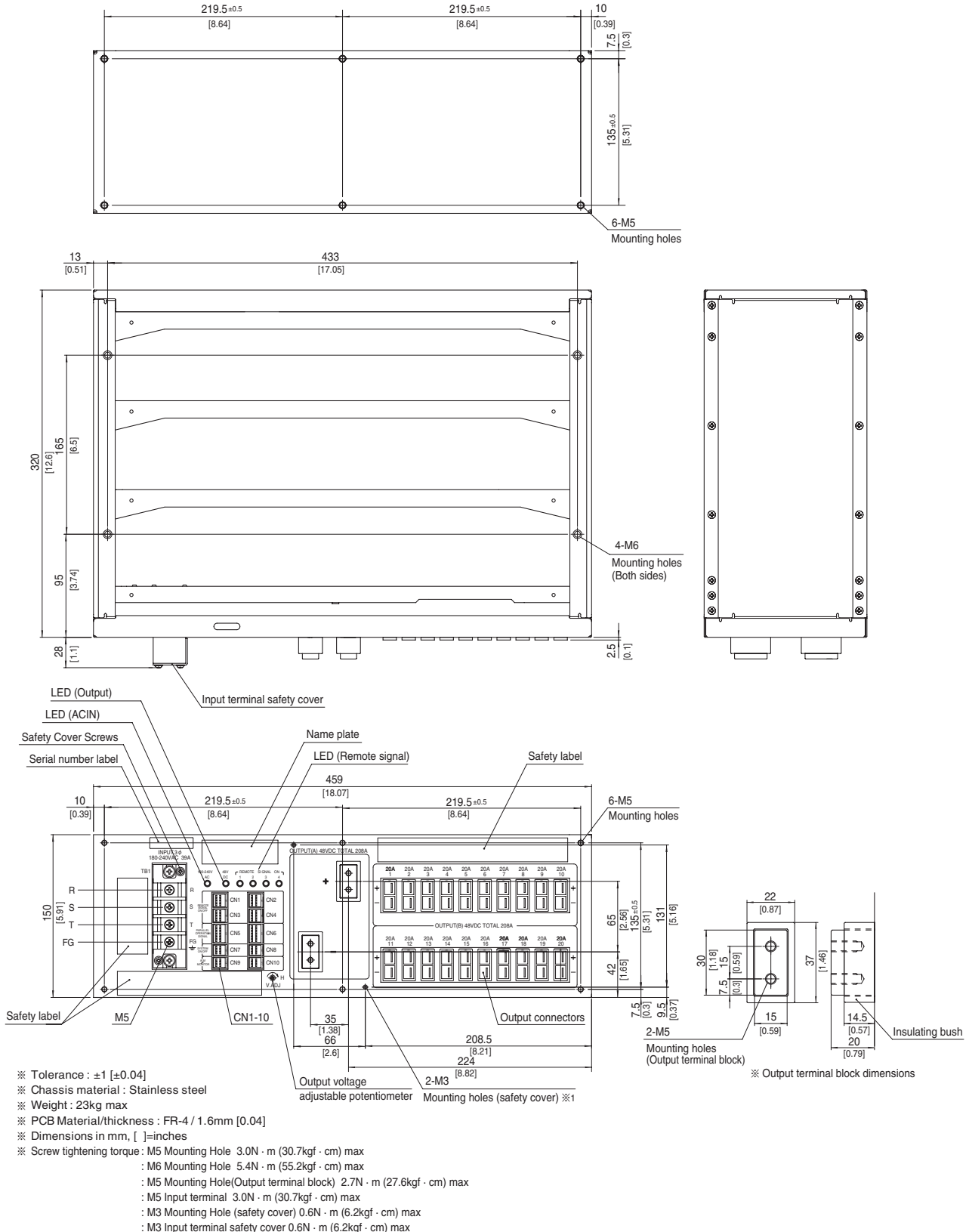

- ※ Tolerance : ±1 [±0.04]
- ※ Chassis material : Stainless steel
- ※ Weight : 23kg max
- ※ PCB Material/thickness : FR-4 / 1.6mm [0.04]
- ※ Dimensions in mm, []=inches
- ※ Screw tightening torque : M5 Mounting Hole 3.0N · m (30.7kgf · cm) max
- : M6 Mounting Hole 5.4N · m (55.2kgf · cm) max
- : M5 Mounting Hole(Output terminal block) 2.7N · m (27.6kgf · cm) max
- : M5 Input terminal 3.0N · m (30.7kgf · cm) max
- : M3 Mounting Hole (safety cover) 0.6N · m (6.2kgf · cm) max
- : M3 Input terminal safety cover 0.6N · m (6.2kgf · cm) max

- ※ LED (ACIN) : White with AC input
- ※ LED (Output) : Green with 48VDC output
- ※ LED (Remote signal) : Green (Indicates Remote signal status)

※ 1 Bus-bar safety cover, optional accessory.

SCDA10000T external view

SC

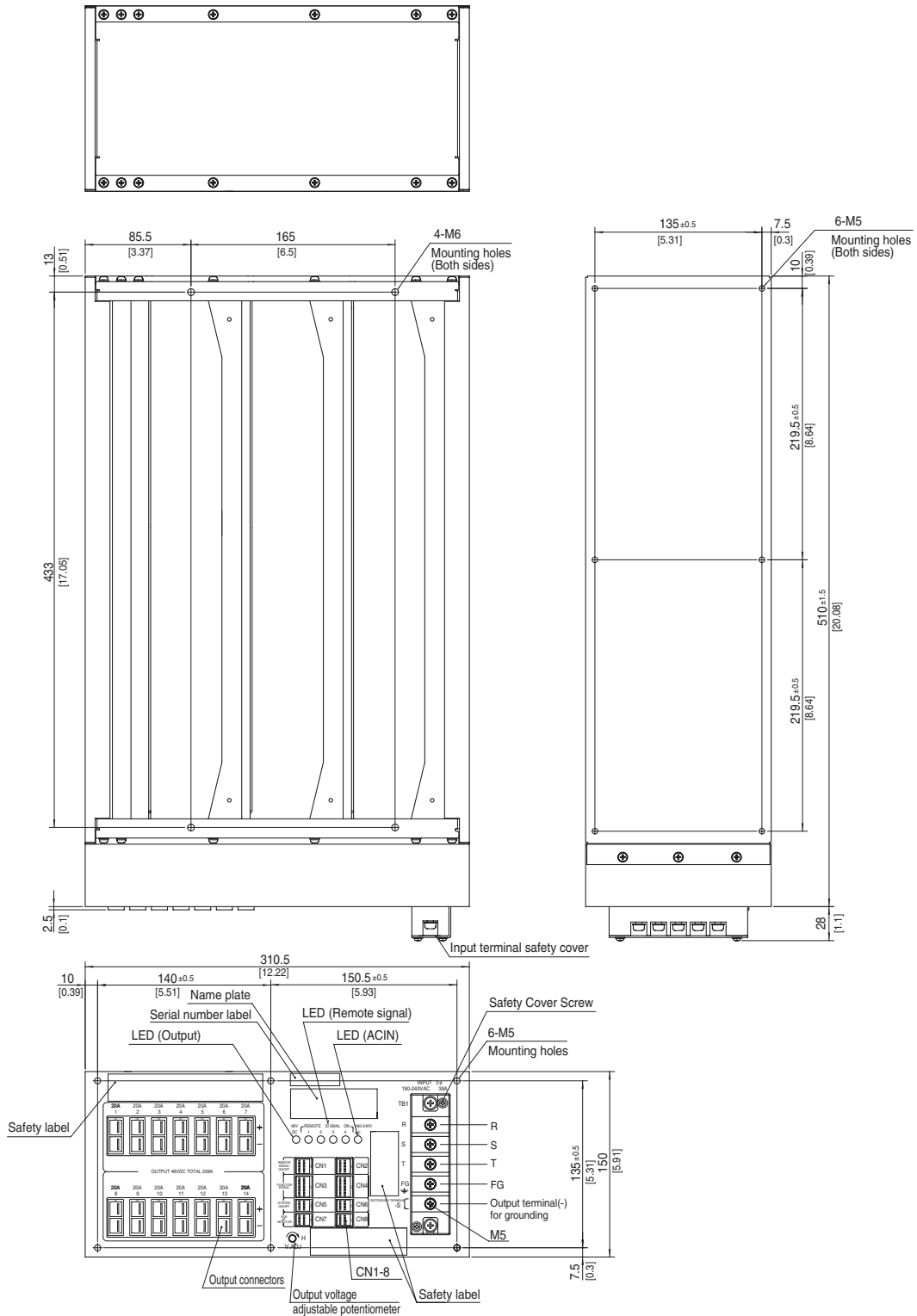

※ Tolerance : ±1 [±0.04]

※ Chassis material : Stainless steel

※ Weight : 20kg max

※ PCB Material/thickness : FR-4 / 1.6mm [0.04]

※ Dimensions in mm, []=inches

※ Screw tightening torque : M5 Mounting Hole 3.0N · m (30.7kgf · cm) max
 : M6 Mounting Hole 5.4N · m (55.2kgf · cm) max
 : M5 Input terminal 3.0N · m (30.7kgf · cm) max
 : M3 Input terminal safety cover 0.6N · m (6.2kgf · cm) max

※ LED (ACIN) : White with AC input

※ LED (Output) : Green with 48VDC output

※ LED (Remote signal) : Green (Indicates Remote signal status)

※ Output terminal(-) for grounding

-Output terminal(-) is internally connected to DC48V Output (-).

-Output terminal(-) : For grounding to stabilize secondary output by connecting to system ground (earth).

-Can not draw current through output terminal(-) for grounding.

SCHA1000T external view (front panel)

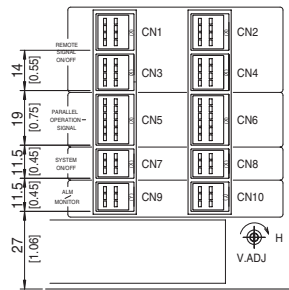
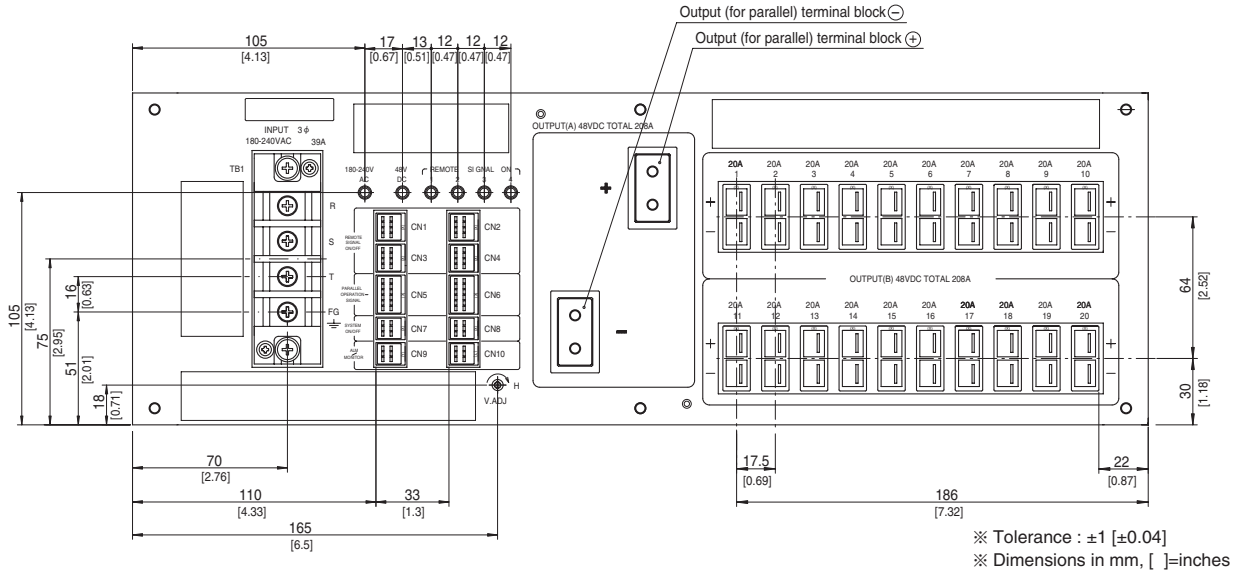

CN1-10 location dimensions

CN1 - 4



CN5 & CN6

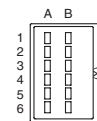

Output Connectors

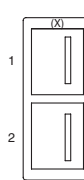

CN7 & CN8



CN9 & CN10



Connector pin numbers

SCHA1000T Functions & Connectors

Connector	Housing	Mfr.	Pin No.	Function
Output connector	1-353080-2	1-179958-2	1	Output (+)
			2	Output (-)
CN1-CN4	1318125-1	1-1318119-4	1A	Remote signal ON/OFF 1+
			1B	Remote signal ON/OFF 1-
			2A	Remote signal ON/OFF 2+
			2B	Remote signal ON/OFF 2-
			3A	Remote signal ON/OFF 3+
			3B	Remote signal ON/OFF 3-
			4A	Remote signal ON/OFF 4+
			4B	Remote signal ON/OFF 4-
CN5 & CN6	1318126-1	1-1318118-6	1A,1B	MAS: Master
			2A,2B	SLV: Slave
			3A,3B	CTB: Current balance
			4A,4B	PCNT: Parallel control
			5A,5B	COM:GND
			6A,6B	N.C.
CN7 & CN8	1318124-1	1-1318119-3	1A,1B	System ON/OFF +
			3A,3B	System ON/OFF -
			2A,2B	N.C.
CN9 & CN10	1318124-2	2-1318119-3	1A,1B	Alarm +
			3A,3B	Alarm -
			2A	+M: Output voltage monitor+
			2B	-M: Output voltage monitor-

SCDA10000T external view (front panel)

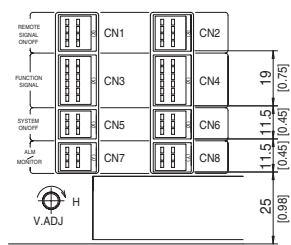
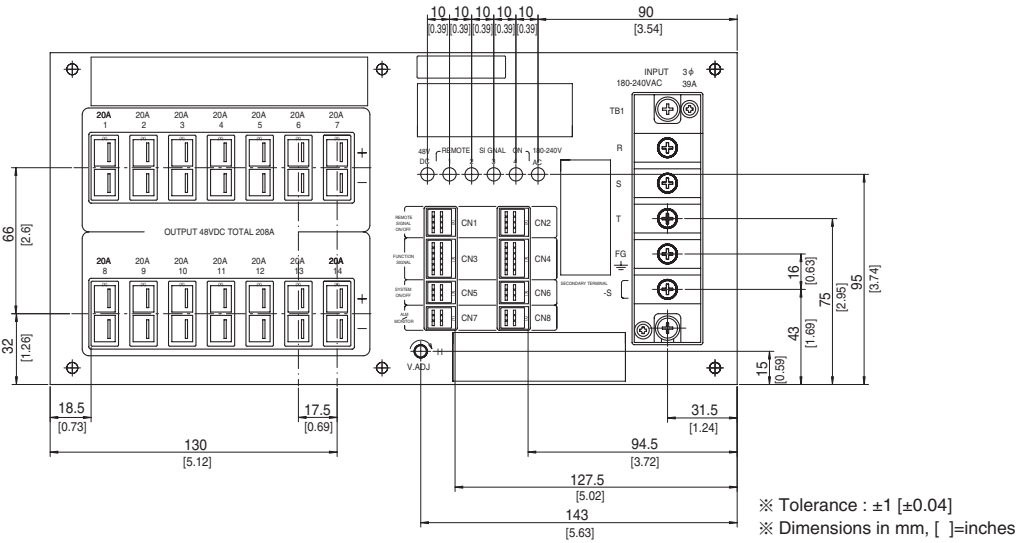

CN1-8 location dimensions

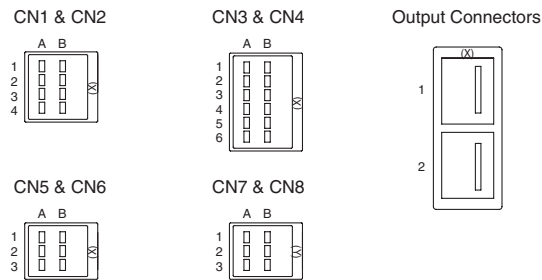

Connector pin numbers

SCDA10000T Functions & Connectors

Connector	Housing	Mfr.	Pin No.	Function	
Output connector	1-353080-2	1-179958-2	1	Output (+)	
			2	Output (-)	
CN1 & CN2	1318125-1	1-1318119-4	Tyco Electronics AMP	1A	Remote signal ON/OFF 1+
				1B	Remote signal ON/OFF 1-
				2A	Remote signal ON/OFF 2+
				2B	Remote signal ON/OFF 2-
				3A	Remote signal ON/OFF 3+
				3B	Remote signal ON/OFF 3-
				4A	Remote signal ON/OFF 4+
				4B	Remote signal ON/OFF 4-
CN3 & CN4	1318126-1	1-1318118-6	Tyco Electronics AMP	1A,1B	MAS: Master
				2A,2B	SLV: Slave
				3A,3B	CTB: Current balance
				4A,4B	PCNT: Parallel control
				5A,5B	COM:GND
				6A,6B	N.C.
CN5 & CN6	1318124-1	1-1318119-3	Tyco Electronics AMP	1A,1B	System ON/OFF +
				3A,3B	System ON/OFF -
				2A,2B	N.C.
CN7 & CN8	1318124-2	2-1318119-3	Tyco Electronics AMP	1A,1B	Alarm +
				3A,3B	Alarm -
				2A	+M: Output voltage monitor+
			2B	-M: Output voltage monitor-	

Connection diagram of function connectors

● SCHA10000T

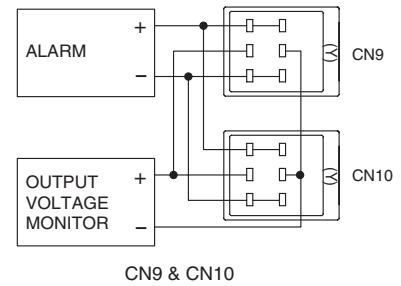
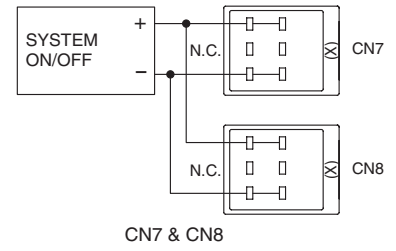
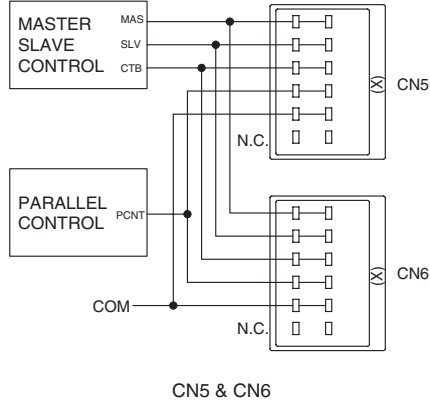
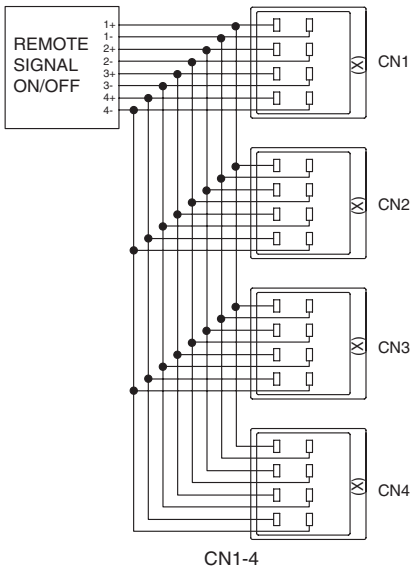

● SCDA10000T

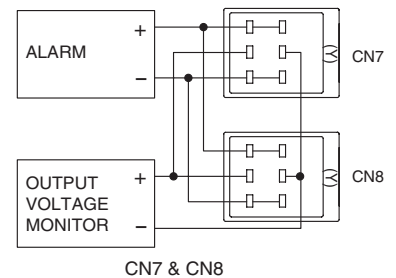
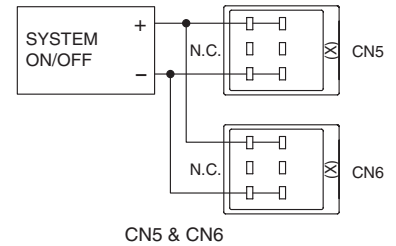
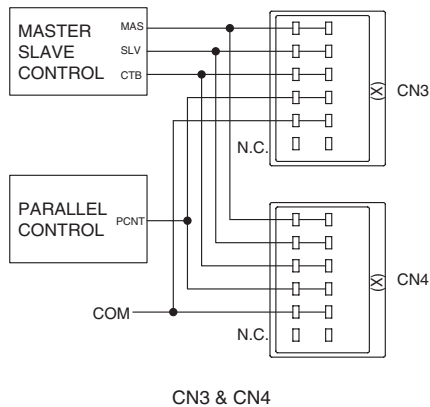
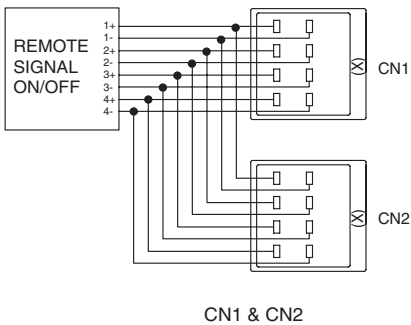

Assembling and Installation Method

Installation method

- Screw mounting has to be consider the product weight for safety fixture.
- To keep enough insulation distance between screws and internal components, length of the mounting screw should not exceed recommendation as right figure.

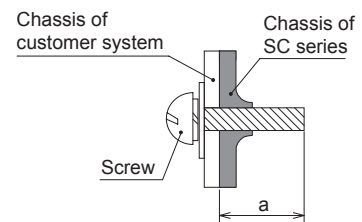

Mounting hole	Diameter	a (Max penetration length)
Chassis	M6	8mm max
	M5	7mm max
Output terminal block (SCHA10000T)	M5	10mm max
Safety cover (Bus bar) (SCHA10000T)	M3	7mm max

Assembling and Installation Method

Cooling Method

This power supply unit is designed for assuming external cooling fans. Follow instruction of cooling condition as follows.

- Built into cooling air flow line in the system (Duct structure air cooling) for uniform cooling air flow.
- Number of stacked units is up to 3, as shown in Fig① and Fig②.
- Air flow direction is either Up or Down as shown in Fig① to Fig③.
- Clearance between stacked units is $1.5\text{mm} \leq d \leq 6\text{mm}$.
- Fig① to Fig③ show the position of cooling fan unit.
- Contact us for more information if your design utilizes other cooling methods.
- Stacking 4 units or more is not allowed.

① Cooling methods for use of single unit

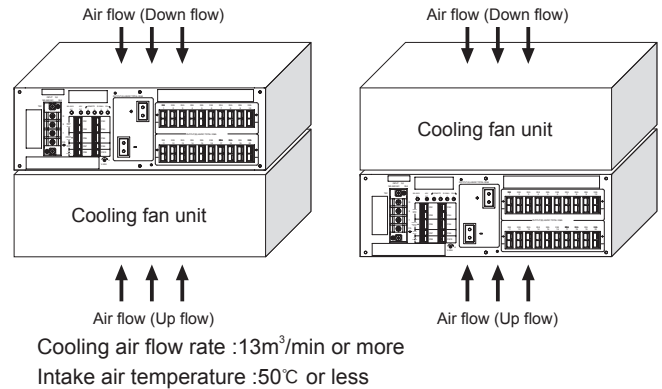

SC

② Cooling methods for use of 2 units

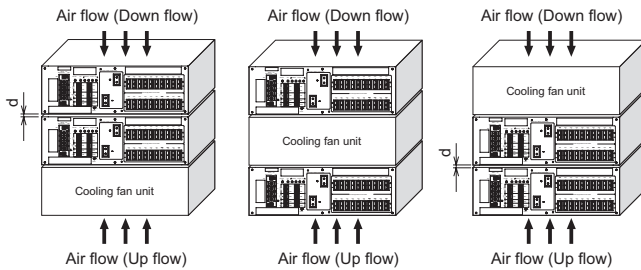

d : gap of power supply units. ($1.5\text{mm} \leq d \leq 6\text{mm}$)

Cooling air flow rate : $13\text{m}^3/\text{min}$ or more
Intake air temperature : 35°C or less

③ Cooling methods for use of 3 units

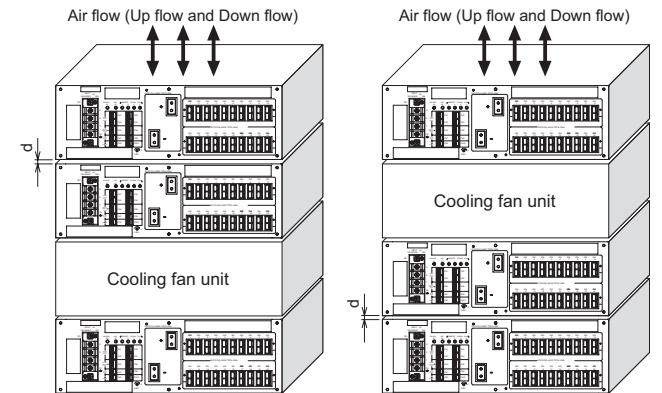

d : gap of power supply units. ($1.5\text{mm} \leq d \leq 6\text{mm}$)

Cooling air flow rate : $13\text{m}^3/\text{min}$ or more
Intake air temperature : 35°C or less

Instruction Manual

- ◆ It is necessary to read the "Instruction Manual" and "Before using our product" before you use our product.

Instruction Manual <https://www.cosel.co.jp/redirect/catalog/en/SC/>

Before using our product <https://en.cosel.co.jp/technical/caution/index.html>

SC



NOTICE



Basic Characteristics Data

Model	Circuit method	Switching frequency [kHz]	Input current [A]	Rated input fuse	Inrush current protection circuit	PCB/Pattern		
						Material	Single sided	Double sided
SCHA 10000T	Active filter	65	35	400V 40A	SCR	FR-4		Double and Multi
	Forward converter	130						
SCDA 10000T	Active filter	65	35	400V 40A	SCR	FR-4		Double and Multi
	Forward converter	130						

* The value of input current is at ACIN 200V 3φ and rated load.



LHA-series

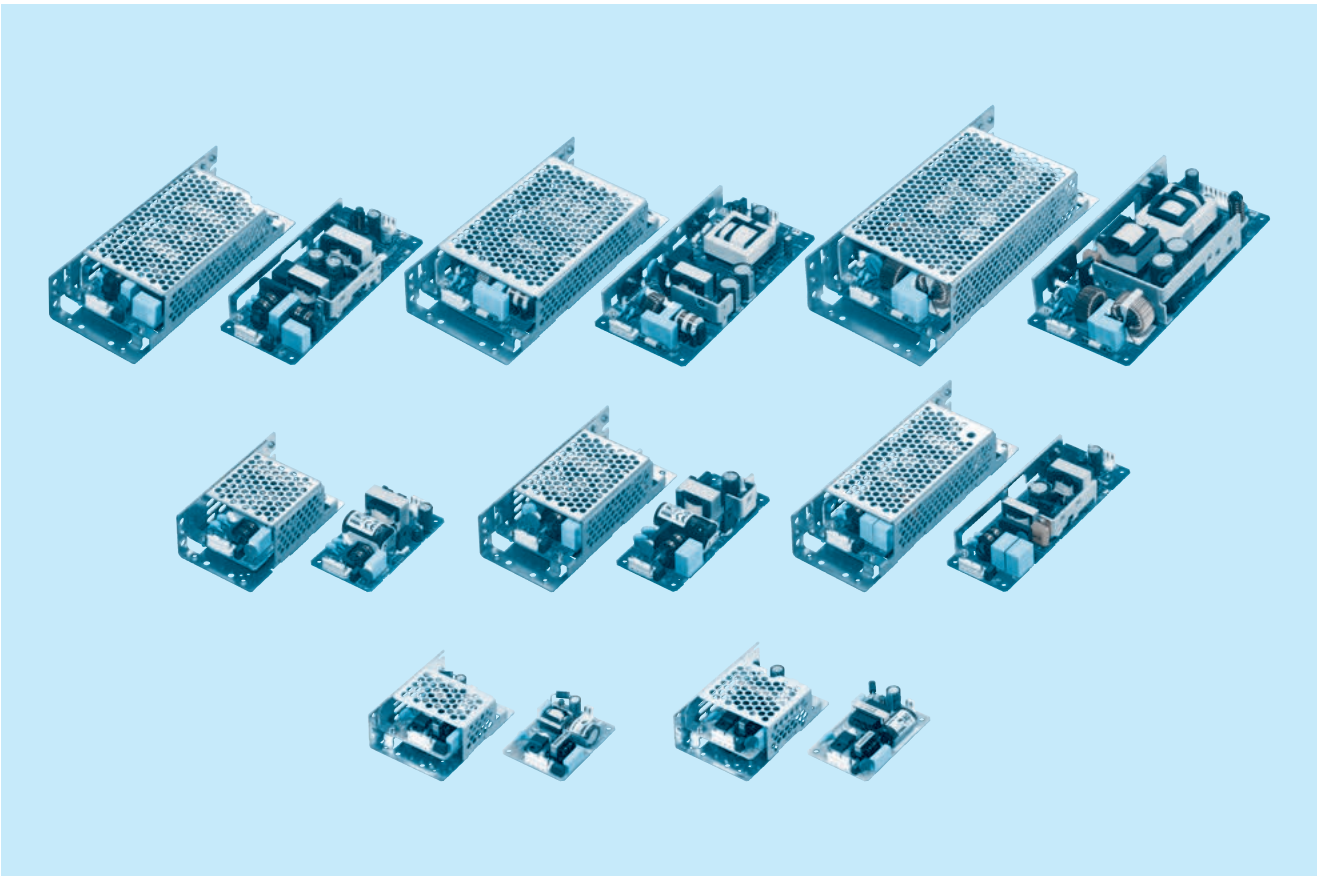

LHA

Feature

- EN62477-1 (OVC III)
- Low-profile
- Small and compact PCB construction
- High efficiency
- Low noise
- Harmonic attenuator (Complies with IEC61000-3-2)
- Power factor correction (LHA75F-300F)
- Universal input (85-264VAC)
- Built-in inrush current, overcurrent and overvoltage protection circuits

Safety agency approvals

- UL62368-1, C-UL (equivalent to CAN/CSA-C22.2 No.62368-1), EN62368-1
- EN62477-1 (OVC III) : LHA150F, 300F
- Complies with DEN-AN

5-year warranty (refer to Instruction Manual)

CE marking

- Low Voltage Directive
- RoHS Directive

UKCA marking

- Electrical Equipment Safety Regulations
- RoHS Regulations

EMI

- Complies with FCC-B, CISPR11-B, CISPR32-B, EN55011-B, EN55032-B, VCCI-B

EMS Compliance : EN61204-3, EN61000-6-2

- EN61000-4-2
- EN61000-4-3
- EN61000-4-4
- EN61000-4-5
- EN61000-4-6
- EN61000-4-8
- EN61000-4-11

LHA10F

LH A 10 F -□□ -□

① ② ③ ④ ⑤ ⑥

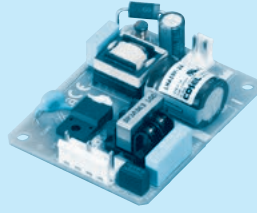
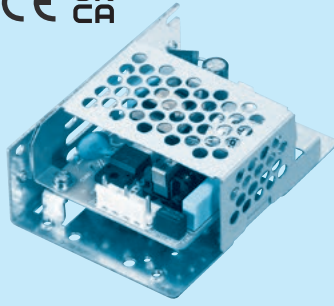

Example recommended EMI/EMC filter
EAC-03-472



High voltage pulse noise type : EAP series
Low leakage current type : EAM series
* A higher current rating EMI/EMC filter may be recommended in view of the other devices that could be connected in parallel with the power supply.

- ① Series name
- ② Single output
- ③ Output wattage
- ④ Universal input
- ⑤ Output voltage
- ⑥ Optional *1
- C : with Coating
- J4 : EP (TE Connectivity) connector type
- S : with Chassis
- SN : with Chassis & cover
- Y : with Potentiometer

For option details, refer to Instruction Manual 6.

This power supply is manufactured by SMD technology. The stress to PCB like twisting or bending causes the defect of the unit, so handle the unit with care.
*Make sure necessary tests will be carried out on your end equipment with the power supply installed in accordance with any required EMC/EMI regulations.

MODEL	LHA10F-3R3-Y	LHA10F-5	LHA10F-12	LHA10F-15	LHA10F-24
MAX OUTPUT WATTAGE[W]	*2 6.6	10	10.8	10.5	12
DC OUTPUT	*2 3.3V 2A	5V 2A	12V 0.9A	15V 0.7A	24V 0.5A

SPECIFICATIONS

	MODEL	LHA10F-3R3-Y	LHA10F-5	LHA10F-12	LHA10F-15	LHA10F-24	
INPUT	VOLTAGE[VAC]	*2 85 - 264 1 φ (Refer to "Derating" and Instruction Manual 1.1)					
	CURRENT[A]	ACIN 100V	0.18typ	0.26typ			
		ACIN 230V	0.10typ	0.14typ			
	FREQUENCY[Hz]	50 / 60 (45 - 440)					
	EFFICIENCY[%]	ACIN 100V	72.0typ	77.0typ	79.5typ	81.0typ	82.5typ
		ACIN 230V	72.0typ	78.5typ	81.0typ	83.0typ	84.5typ
INRUSH CURRENT[A]	ACIN 100V	15typ (Io=100%)					
	ACIN 230V	35typ (Io=100%)					
	LEAKAGE CURRENT[mA]	0.07 / 0.15max (ACIN 100V / 240V, 60Hz, Io=100%, According to IEC62368-1, and DEN-AN)					
OUTPUT	VOLTAGE[V]	3.3	5	12	15	24	
	CURRENT[A]	*2 2.0	2.0	0.9	0.7	0.5	
	LINE REGULATION[mV]	*3 20max	20max	48max	60max	96max	
	LOAD REGULATION[mV]	*3 40max	40max	100max	120max	150max	
	RIPPLE[mVp-p]	*4	0 to +60°C *7	80max	80max	120max	120max
			-10 to 0°C	140max	140max	160max	160max
			Io=0 to 25%	300max	300max	300max	300max
	RIPPLE NOISE[mVp-p]	*4	0 to +60°C *7	120max	120max	150max	150max
			-10 to 0°C	160max	160max	180max	180max
			Io=0 to 25%	360max	360max	360max	360max
	TEMPERATURE REGULATION[mV]	0 to +60°C *7	50max	50max	120max	150max	240max
		-10 to +60°C *7	60max	60max	150max	180max	290max
	DRIFT[mV]	*5 20max	20max	48max	60max	96max	
START-UP TIME[ms]	40typ (ACIN 100V, Io=100%)						
HOLD-UP TIME[ms]	20typ (ACIN 100V, Io=100%) / 150typ (ACIN 230V, Io=100%)						
OUTPUT VOLTAGE ADJUSTMENT RANGE[V]	2.85 to 3.63		Fixed ("Y"option is available for adjusting output voltage between ±10%)				
OUTPUT VOLTAGE SETTING[V]	3.30 to 3.40	4.90 to 5.30	11.50 to 12.50	14.40 to 15.60	23.00 to 25.00		
PROTECTION CIRCUIT AND OTHERS	OVERCURRENT PROTECTION	Works over 105% of rating and recovers automatically					
	OVERVOLTAGE PROTECTION	4.00 to 6.00	5.75 to 8.00	13.80 to 18.00	17.25 to 23.30	27.60 to 34.50	
	OPERATING INDICATION	Not provided					
	REMOTE SENSING	Not provided					
ISOLATION	INPUT-OUTPUT	AC3,000V 1minute, Cutoff current = 10mA, DC500V 100MΩ min (At Room Temperature)					
	INPUT-FG	AC2,000V 1minute, Cutoff current = 10mA, DC500V 100MΩ min (At Room Temperature)					
	OUTPUT-FG	AC500V 1minute, Cutoff current = 25mA, DC500V 100MΩ min (At Room Temperature)					
ENVIRONMENT	OPERATING TEMP., HUMID. AND ALTITUDE	*2 -10 to +70°C, 20 - 90%RH (Non condensing), 5,000m (16,500feet) max					
	STORAGE TEMP., HUMID. AND ALTITUDE	-20 to +75°C, 20 - 90%RH (Non condensing), 9,000m (30,000feet) max					
	VIBRATION	10 - 55Hz, 19.6m/s ² (2G), 3minutes period, 60minutes each along X, Y and Z axis					
	IMPACT	196.1m/s ² (20G), 11ms, once each X, Y and Z axis					
SAFETY AND NOISE REGULATIONS	AGENCY APPROVALS	UL62368-1, C-UL (equivalent to CAN/CSA-C22.2No.62368-1), EN62368-1, Complies with DEN-AN					
	CONDUCTED NOISE	Complies with FCC-B, VCCI-B, CISPR11-B, CISPR32-B, EN55011-B, EN55032-B					
	HARMONIC ATTENUATOR	*6 Complies with IEC61000-3-2 (Class A) (No built-in power factor correction)					
OTHERS	CASE SIZE/WEIGHT	50 X 21.5 X 62.5mm [1.97 X 0.85 X 2.46 inches] (W X H X D) / 45g max					
	COOLING METHOD	*2 Convection/Forced air (Requires external fan) (Refer to "Derating")					

*1 The listed options may affect the published standard specifications. Please contact us for detailed product specifications.
*2 Derating is required.
*3 At low load conditions, the burst mode operation will start. To check load regulation, you will need to measure the characteristics at average mode with instruments.
*4 This is the value that measured on measuring board with capacitor of 22 μF and 0.1 μF at 150mm from output terminal. Measured by 20MHz oscilloscope or Ripple-Noise meter (Equivalent to KEISOKU-GIKEN:RM104).
Ripple and ripple noise spec is change at Io=0 to 25% by burst operation.
Audible noise may be generated.

*5 Drift is the change in DC output for an eight hour period after a half-hour warm-up at 25°C, with the input voltage held constant at the rated input/output.
*6 Please contact us about another class. When two or more units are operating it may not comply with the IEC61000-3-2. Please contact us for details.
*7 3.3V, 5V, 12V output product, the maximum temperature of 55°C.
* To meet the specification, do not operate overload condition.
* Parallel operation is not possible.
* Sound noise may be generated by power supply in case of pulse load.

Block diagram

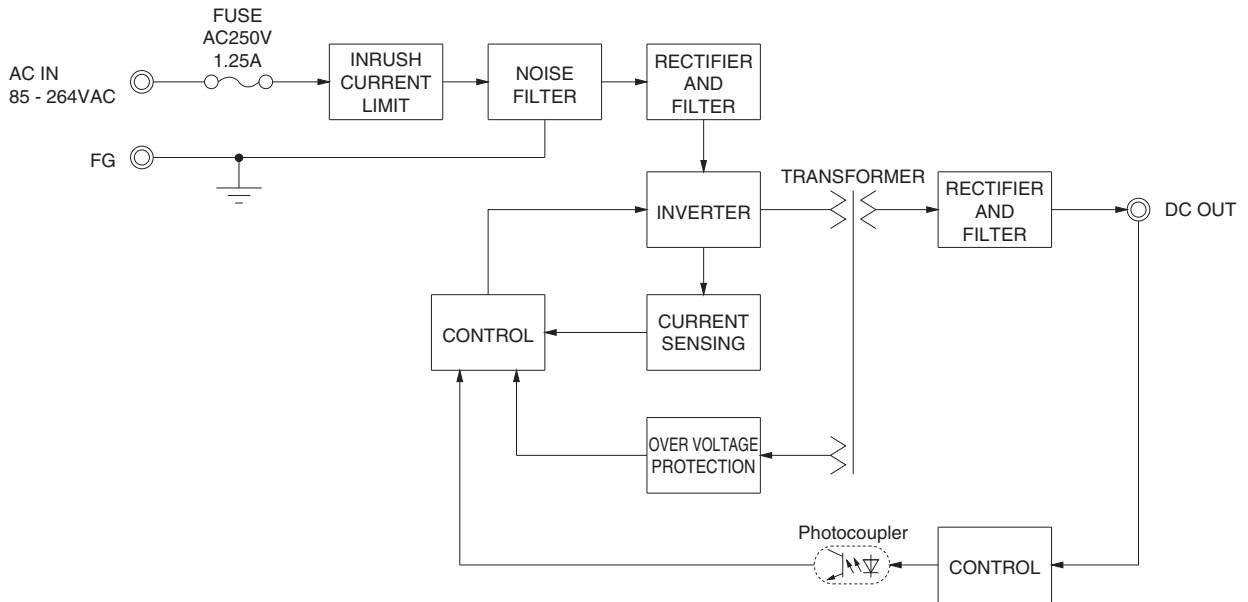

LHA

External view

※ External size of option is different from standard type.

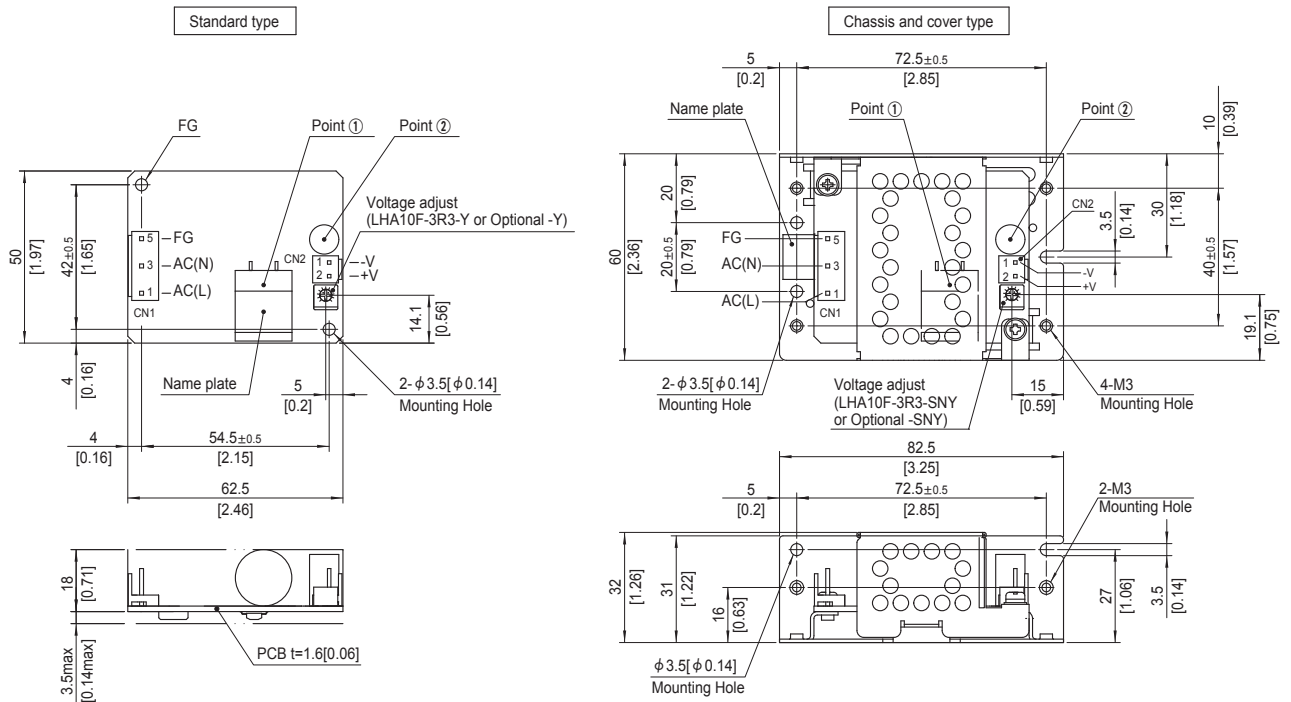

- ※ The back side of PCB of the power supply is assembled some SMDs.
Be careful not to bump against the attached area by vibration.
- ※ Use the spacer of 8mm [0.31] length or more for isolation.
And do not use press-fitting bush.
- ※ Point ①, Point ② are thermometry points. Please refer to Instruction Manual 3.

I/O Connector	Mating connector	Terminal
CN1	B3P5-VH	Chain SVH-21T-P1.1
		Loose BVH-21T-P1.1
CN2	B2P-VH	Chain SVH-21T-P1.1
		Loose BVH-21T-P1.1

(Mfr: J.S.T.)

- ※ I/O Connector is Mfr.J.S.T.
- ※ Option:-J4:EP (TE Connectivity) connector type.

Pin No.	Input
1	AC(L)
2	
3	AC(N)
4	
5	FG

※ Pin No.2 and 4 is NC at CN1.

Pin No.	Output
1	-V
2	+V

- ※ Dimensions in mm, []=inches
- ※ Tolerance : ±1 [±0.04]
- ※ Weight : 45g max (with chassis and cover : 115g max)
- ※ PCB Material / thickness : CEM-3 / 1.6mm [0.06]
- ※ Optional chassis and cover material : Galvanizing steel board
- ※ Mounting torque (Mounting hole of chassis) : 1.5N · m max

LHA15F

LH A 15 F -□□ -□
 ① ② ③ ④ ⑤ ⑥

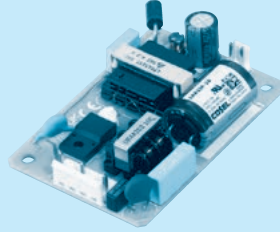
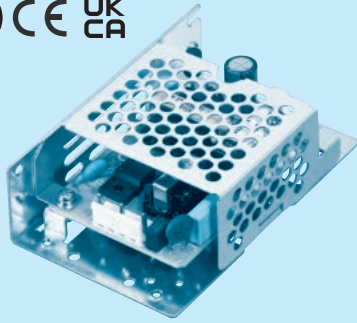

Example recommended EMI/EMC filter
EAC-03-472



High voltage pulse noise type : EAP series
 Low leakage current type : EAM series
 * A higher current rating EMI/EMC filter may be recommended in view of the other devices that could be connected in parallel with the power supply.

- ① Series name
- ② Single output
- ③ Output wattage
- ④ Universal input
- ⑤ Output voltage
- ⑥ Optional *1
- C : with Coating
- J4 : EP (TE Connectivity) connector type
- S : with Chassis
- SN : with Chassis & cover
- Y : with Potentiometer

For option details, refer to Instruction Manual 6.

This power supply is manufactured by SMD technology. The stress to PCB like twisting or bending causes the defect of the unit, so handle the unit with care.
 *Make sure necessary tests will be carried out on your end equipment with the power supply installed in accordance with any required EMC/EMI regulations.

MODEL	LHA15F-3R3-Y	LHA15F-5	LHA15F-12	LHA15F-15	LHA15F-24
MAX OUTPUT WATTAGE[W]	*2 9.9	15	15.6	15	16.8
DC OUTPUT	*2 3.3V 3A	5V 3A	12V 1.3A	15V 1.0	24V 0.7A

SPECIFICATIONS

	MODEL	LHA15F-3R3-Y	LHA15F-5	LHA15F-12	LHA15F-15	LHA15F-24	
INPUT	VOLTAGE[VAC]	*2 85 - 264 1 φ (Refer to "Derating" and Instruction Manual 1.1)					
	CURRENT[A]	ACIN 100V	0.24typ	0.35typ			
		ACIN 230V	0.15typ	0.19typ			
	FREQUENCY[Hz]	50 / 60 (45 - 440)					
	EFFICIENCY[%]	ACIN 100V	71.5typ	75.0typ	79.0typ	80.0typ	81.5typ
		ACIN 230V	72.5typ	77.0typ	82.0typ	83.0typ	84.5typ
	INRUSH CURRENT[A]	ACIN 100V	15typ (Io=100%) Ta=25°C at cold start				
	ACIN 230V	35typ (Io=100%) Ta=25°C at cold start					
LEAKAGE CURRENT[mA]	0.05 / 0.10max (ACIN 100V / 240V, 60Hz, Io=100%, According to IEC62368-1, and DEN-AN)						
OUTPUT	VOLTAGE[V]	3.3	5	12	15	24	
	CURRENT[A]	*2 3.0	3.0	1.3	1.0	0.7	
	LINE REGULATION[mV]	*3 20max	20max	48max	60max	96max	
	LOAD REGULATION[mV]	*3 40max	40max	100max	120max	150max	
	RIPPLE[mVp-p]	*4	0 to +60°C *7	80max	80max	120max	120max
			-10 to 0°C	140max	140max	160max	160max
			Io=0 to 25%	300max	300max	300max	300max
	RIPPLE NOISE[mVp-p]	*4	0 to +60°C *7	120max	120max	150max	150max
			-10 to 0°C	160max	160max	180max	180max
			Io=0 to 25%	360max	360max	360max	360max
	TEMPERATURE REGULATION[mV]	0 to +60°C *7	50max	50max	120max	150max	240max
		-10 to +60°C *7	60max	60max	150max	180max	290max
	DRIFT[mV]	*5 20max	20max	48max	60max	96max	
START-UP TIME[ms]	40typ (ACIN 100V, Io=100%)						
HOLD-UP TIME[ms]	20typ (ACIN 100V, Io=100%) / 150typ (ACIN 230V, Io=100%)						
OUTPUT VOLTAGE ADJUSTMENT RANGE[V]	2.85 to 3.63		Fixed ("Y"option is available for adjusting output voltage between ±10%)				
OUTPUT VOLTAGE SETTING[V]	3.30 to 3.40	4.90 to 5.30	11.50 to 12.50	14.40 to 15.60	23.00 to 25.00		
PROTECTION CIRCUIT AND OTHERS	OVERCURRENT PROTECTION	Works over 105% of rating and recovers automatically					
	OVERVOLTAGE PROTECTION	4.00 to 6.00	5.75 to 8.00	13.80 to 18.00	17.25 to 23.30	27.60 to 34.50	
	OPERATING INDICATION	Not provided					
	REMOTE SENSING	Not provided					
ISOLATION	INPUT-OUTPUT	AC3,000V 1minute, Cutoff current = 10mA, DC500V 100MΩ min (At Room Temperature)					
	INPUT-FG	AC2,000V 1minute, Cutoff current = 10mA, DC500V 100MΩ min (At Room Temperature)					
	OUTPUT-FG	AC500V 1minute, Cutoff current = 25mA, DC500V 100MΩ min (At Room Temperature)					
ENVIRONMENT	OPERATING TEMP., HUMID. AND ALTITUDE *2	-10 to +70°C, 20 - 90%RH (Non condensing), 5,000m (16,500feet) max					
	STORAGE TEMP., HUMID. AND ALTITUDE	-20 to +75°C, 20 - 90%RH (Non condensing), 9,000m (30,000feet) max					
	VIBRATION	10 - 55Hz, 19.6m/s ² (2G), 3minutes period, 60minutes each along X, Y and Z axis					
	IMPACT	196.1m/s ² (20G), 11ms, once each X, Y and Z axis					
SAFETY AND NOISE REGULATIONS	AGENCY APPROVALS	UL62368-1, C-UL (equivalent to CAN/CSA-C22.2No.62368-1), EN62368-1, Complies with DEN-AN					
	CONDUCTED NOISE	Complies with FCC-B, VCCI-B, CISPR11-B, CISPR32-B, EN55011-B, EN55032-B					
	HARMONIC ATTENUATOR *6	Complies with IEC61000-3-2 (Class A) (No built-in power factor correction)					
OTHERS	CASE SIZE/WEIGHT	50 X 21.5 X 73.5mm [1.97 X 0.85 X 2.89 inches] (W X H X D) / 60g max					
	COOLING METHOD *2	Convection/Forced air (Requires external fan) (Refer to "Derating")					

*1 The listed options may affect the published standard specifications. Please contact us for detailed product specifications.
 *2 Derating is required.
 *3 At low load conditions, the burst mode operation will start. To check load regulation, you will need to measure the characteristics at average mode with instruments.
 *4 This is the value that measured on measuring board with capacitor of 22 μF and 0.1 μF at 150mm from output terminal. Measured by 20MHz oscilloscope or Ripple-Noise meter (Equivalent to KEISOKU-GIKEN:RM104).
 Ripple and ripple noise spec is change at Io=0 to 25% by burst operation.
 Audible noise may be generated.

*5 Drift is the change in DC output for an eight hour period after a half-hour warm-up at 25°C, with the input voltage held constant at the rated input/output.
 *6 Please contact us about another class. When two or more units are operating it may not comply with the IEC61000-3-2. Please contact us for details.
 *7 3.3V, 5V, 12V output product, the maximum temperature of 55°C.
 * To meet the specification, do not operate overload condition.
 * Parallel operation is not possible.
 * Sound noise may be generated by power supply in case of pulse load.

Block diagram

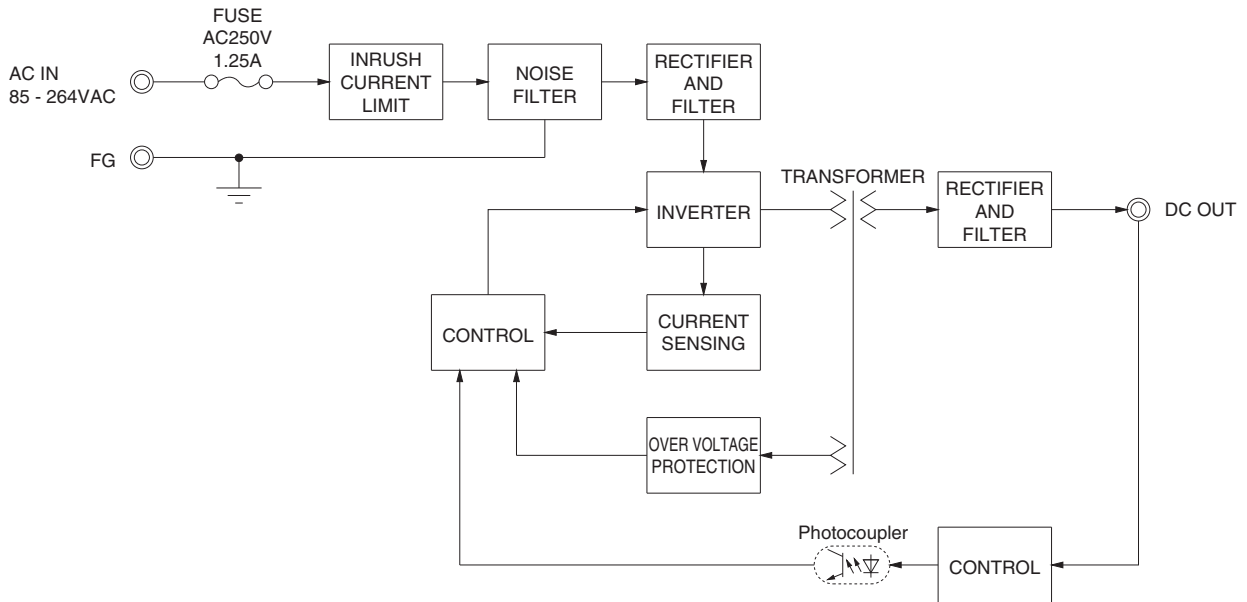

LHA

External view

※ External size of option is different from standard type.

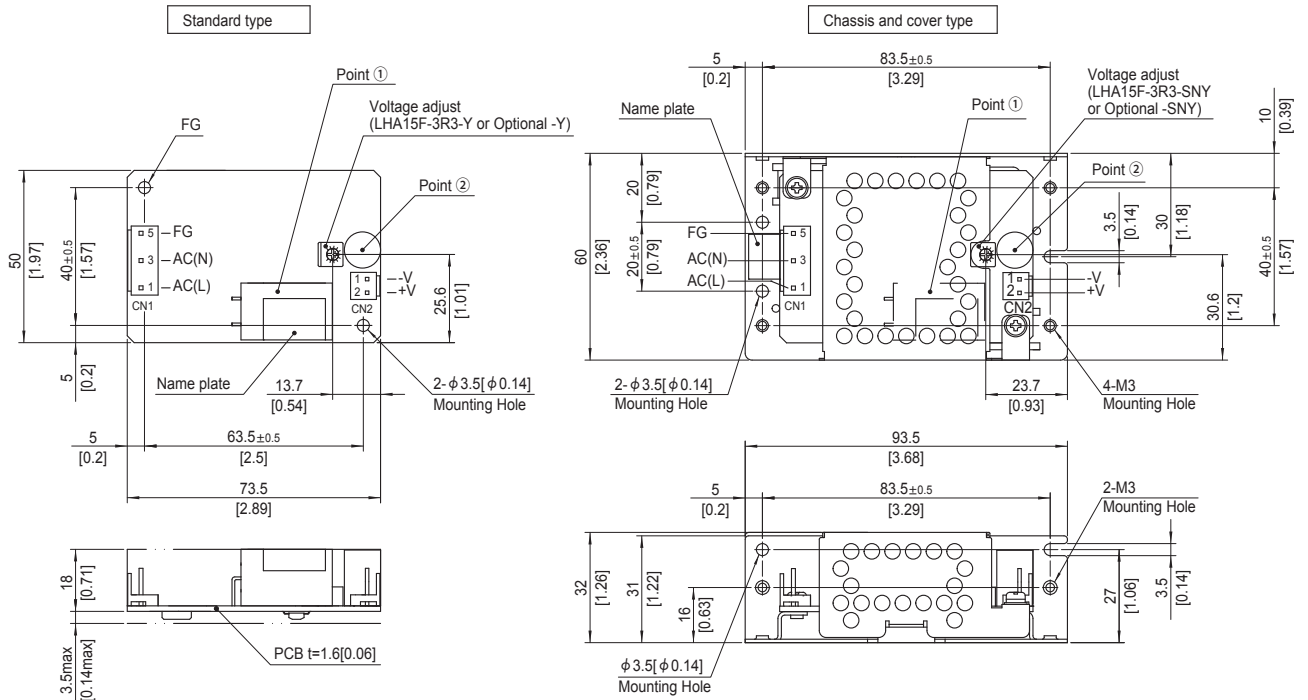

※ The back side of PCB of the power supply is assembled some SMDs.

Be careful not to bump against the attached area by vibration.

※ Use the spacer of 8mm [0.31] length or more for isolation. And do not use press-fitting bush.

※ Point ①, Point ② are thermometry points. Please refer to Instruction Manual 3.

I/O Connector	Mating connector	Terminal
CN1	B3P5-VH	VHR-5N
		Chain SVH-21T-P1.1
CN2	B2P-VH	Loose BVH-21T-P1.1
		Chain SVH-21T-P1.1
		Loose BVH-21T-P1.1

(Mfr: J.S.T.)

※ I/O Connector is Mfr. J.S.T.

※ Option: -J4:EP (TE Connectivity) connector type.

CN1

Pin No.	Input
1	AC(L)
2	
3	AC(N)
4	
5	FG

※ Pin No.2 and 4 is NC at CN1.

CN2

Pin No.	Output
1	-V
2	+V

※ Dimensions in mm, []=inches

※ Tolerance : ±1 [±0.04]

※ Weight : 60g max (with chassis and cover : 140g max)

※ PCB Material / thickness : CEM-3 / 1.6mm [0.06]

※ Optional chassis and cover material : Galvanizing steel board

※ Mounting torque (Mounting hole of chassis) : 1.5N · m max

LHA30F

LH A 30 F -□□ -□

① ② ③ ④ ⑤ ⑥

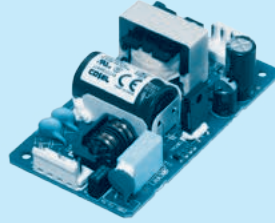
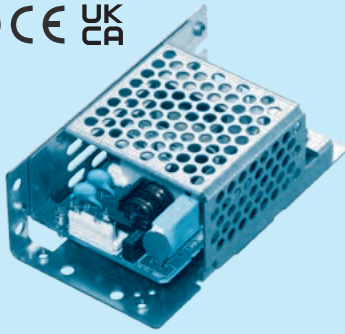

Example recommended EMI/EMC filter
EAC-03-472



High voltage pulse noise type : EAP series
Low leakage current type : EAM series
* A higher current rating EMI/EMC filter may be recommended in view of the other devices that could be connected in parallel with the power supply.

- ① Series name
- ② Single output
- ③ Output wattage
- ④ Universal input
- ⑤ Output voltage
- ⑥ Optional *1
- C : with Coating
- G : Low leakage current
- J4 : EP (TE Connectivity) connector type
- S : with Chassis
- SN : with Chassis & cover
- Y : with Potentiometer

For option details, refer to Instruction Manual 6.

This power supply is manufactured by SMD technology. The stress to PCB like twisting or bending causes the defect of the unit, so handle the unit with care.
*Make sure necessary tests will be carried out on your end equipment with the power supply installed in accordance with any required EMC/EMI regulations.

MODEL	LHA30F-3R3-Y	LHA30F-5	LHA30F-12	LHA30F-15	LHA30F-24
MAX OUTPUT WATTAGE[W]	*2 19.8	30	30	30	31.2
DC OUTPUT	*2 3.3V6A	5V6A	12V2.5A	15V2A	24V1.3A

SPECIFICATIONS

	MODEL	LHA30F-3R3-Y	LHA30F-5	LHA30F-12	LHA30F-15	LHA30F-24		
INPUT	VOLTAGE[VAC]	*2 85 - 264 1 φ (Refer to "Derating" and Instruction Manual 1.1)						
	CURRENT[A]	ACIN 100V	0.42typ	0.62typ				
		ACIN 230V	0.23typ	0.32typ				
	FREQUENCY[Hz]	50 / 60 (45 - 440)						
	EFFICIENCY[%]	ACIN 100V	83.0typ	83.0typ	85.0typ	85.5typ	87.0typ	
		ACIN 230V	85.5typ	87.0typ	88.5typ	89.0typ	90.0typ	
INRUSH CURRENT[A]	ACIN 100V	15typ (Io=100%) Ta=25°C at cold start						
	ACIN 230V	35typ (Io=100%) Ta=25°C at cold start						
LEAKAGE CURRENT[mA]	0.20 / 0.45max (ACIN 100V / 240V 60Hz, Io=100%, According to IEC62368-1 and DEN-AN)							
OUTPUT	VOLTAGE[V]	3.3	5	12	15	24		
	CURRENT[A]	*2 6.0	6.0	2.5	2.0	1.3		
	LINE REGULATION[mV]	*3 20max	20max	48max	60max	96max		
	LOAD REGULATION[mV]	*3 40max	40max	100max	120max	150max		
	RIPPLE[mVp-p]	*4	0 to +50°C	80max	80max	120max	120max	120max
			-10 to 0°C	140max	140max	160max	160max	160max
			Io=0 to 15%	300max	300max	300max	300max	300max
	RIPPLE NOISE[mVp-p]	*4	0 to +50°C	120max	120max	150max	150max	150max
			-10 to 0°C	160max	160max	180max	180max	180max
			Io=0 to 15%	360max	360max	360max	360max	360max
	TEMPERATURE REGULATION[mV]	0 to +50°C	50max	50max	120max	150max	240max	
		-10 to +50°C	60max	60max	150max	180max	290max	
	DRIFT[mV]	*5 20max	20max	48max	60max	96max		
	START-UP TIME[ms]	40typ (ACIN 100V, Io=100%)						
HOLD-UP TIME[ms]	25typ (ACIN 100V, Io=100%) / 170typ (ACIN 230V, Io=100%)							
OUTPUT VOLTAGE ADJUSTMENT RANGE[V]	2.85 to 3.63		Fixed ("Y"option is available for adjusting output voltage between ±10%)					
OUTPUT VOLTAGE SETTING[V]	3.30 to 3.40		4.90 to 5.30		11.50 to 12.50 / 14.40 to 15.60 / 23.00 to 25.00			
PROTECTION CIRCUIT AND OTHERS	OVERCURRENT PROTECTION	Works over 105% of rating and recovers automatically						
	OVERVOLTAGE PROTECTION	4.00 to 5.25	5.75 to 7.00	13.80 to 16.80	17.25 to 21.00	27.60 to 33.60		
	OPERATING INDICATION	Not provided						
	REMOTE SENSING	Not provided						
ISOLATION	INPUT-OUTPUT	AC3,000V 1minute, Cutoff current = 10mA, DC500V 100MΩ min (At Room Temperature)						
	INPUT-FG	AC2,000V 1minute, Cutoff current = 10mA, DC500V 100MΩ min (At Room Temperature)						
	OUTPUT-FG	AC500V 1minute, Cutoff current = 25mA, DC500V 100MΩ min (At Room Temperature)						
ENVIRONMENT	OPERATING TEMP., HUMID. AND ALTITUDE	*2 -10 to +70°C, 20 - 90%RH (Non condensing), 5,000m (16,500feet) max						
	STORAGE TEMP., HUMID. AND ALTITUDE	-20 to +75°C, 20 - 90%RH (Non condensing), 9,000m (30,000feet) max						
	VIBRATION	10 - 55Hz, 19.6m/s ² (2G), 3minutes period, 60minutes each along X, Y and Z axis						
	IMPACT	196.1m/s ² (20G), 11ms, once each X, Y and Z axis						
SAFETY AND NOISE REGULATIONS	AGENCY APPROVALS	UL62368-1, C-UL (equivalent to CAN/CSA-C22.2No.62368-1), EN62368-1, Complies with DEN-AN						
	CONDUCTED NOISE	Complies with FCC-B, VCCI-B, CISPR11-B, CISPR32-B, EN55011-B, EN55032-B						
	HARMONIC ATTENUATOR	*6 Complies with IEC61000-3-2 (Class A) (No built-in power factor correction)						
OTHERS	CASE SIZE/WEIGHT	50 X 27 X 87.5mm [1.97 X 1.07 X 3.44 inches] (W X H X D) / 100g max (with chassis & cover : 210g max)						
	COOLING METHOD	*2 Convection/Forced air (Requires external fan) (Refer to "Derating")						

*1 The listed options may affect the published standard specifications. Please contact us for detailed product specifications.
*2 Derating is required.
*3 At low load conditions, the burst mode operation will start. To check load regulation, you will need to measure the characteristics at average mode with instruments.
*4 This is the value that measured on measuring board with capacitor of 22 μF and 0.1 μF at 150mm from output terminal. Measured by 20MHz oscilloscope or Ripple-Noise meter (Equivalent to KEISOKU-GIKEN:RM104).
Ripple and ripple noise spec is change at Io=0 to 15% by burst operation.

*5 Drift is the change in DC output for an eight hour period after a half-hour warm-up at 25°C, with the input voltage held constant at the rated input/output.
*6 Please contact us about another class. When two or more units are operating it may not comply with the IEC61000-3-2. Please contact us for details.
* To meet the specification, do not operate overload condition.
* Parallel operation is not possible.
* Sound noise may be generated by power supply in case of pulse load.

Block diagram

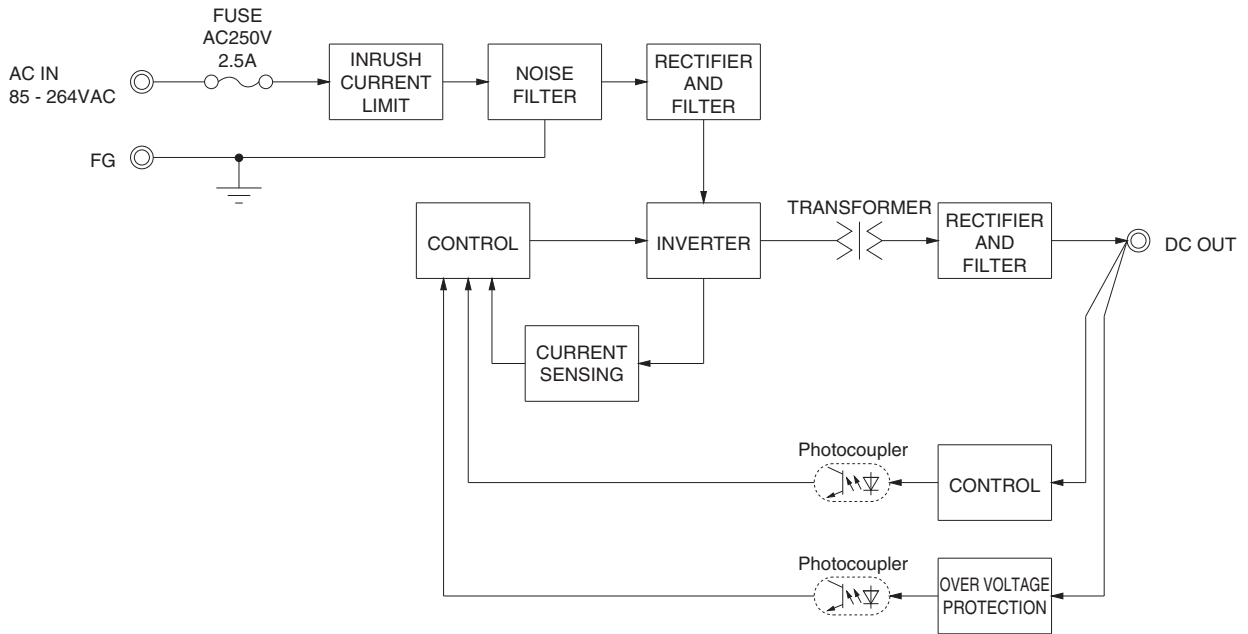

LHA

External view

※ External size of option is different from standard type.

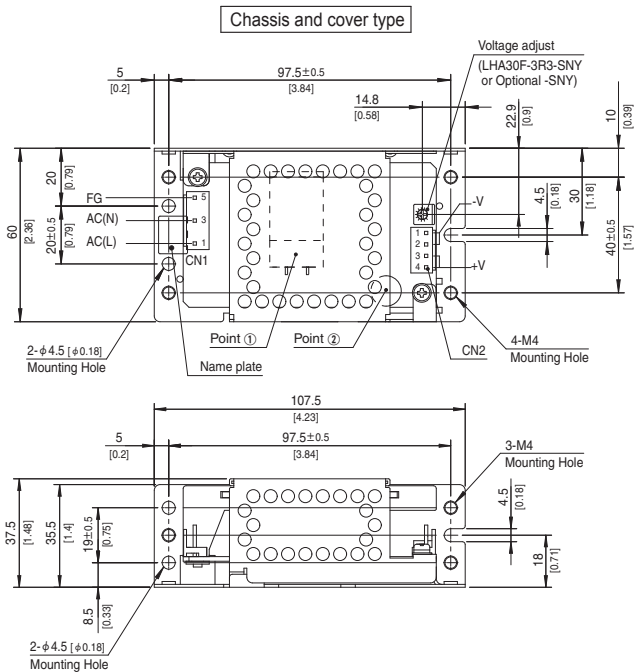
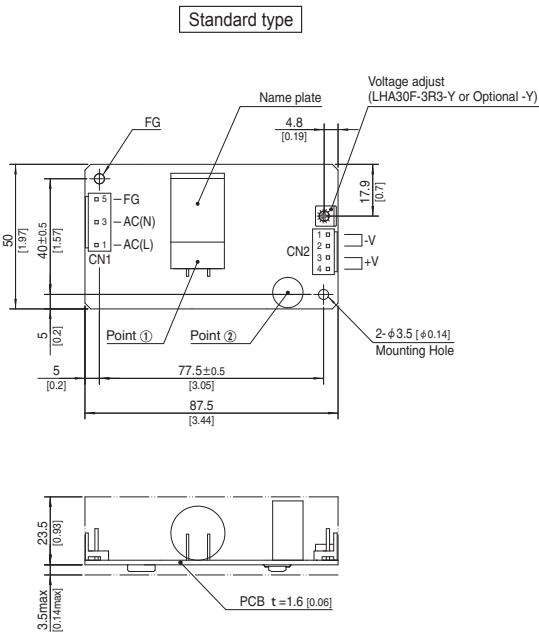

- ※ The back side of PCB of the power supply is assembled some SMDs.
Be careful not to bump against the attached area by vibration.
- ※ Use the spacer of 8mm [0.31] length or more for isolation.
And do not use press-fitting bush.
- ※ Point ①, Point ② are thermometry points. Please refer to Instruction Manual 3.

I/O Connector	Mating connector	Terminal
CN1	B3P5-VH	Chain SVH-21T-P1.1
		Loose BVH-21T-P1.1
CN2	B4P-VH	Chain SVH-21T-P1.1
		Loose BVH-21T-P1.1

(Mfr: J.S.T.)

- ※ I/O Connector is Mfr. J.S.T.
- ※ Option: -J4:EP (TE Connectivity) connector type.

Pin No.	Input
1	AC(L)
2	
3	AC(N)
4	
5	FG

Pin No.	Output
1, 2	-V
3, 4	+V

- ※ Pin No.2 and 4 is NC at CN1.
- ※ Keep drawing current per pin below 5A for CN2.

- ※ Dimensions in mm, []=inches
- ※ Tolerance : ±1 [±0.04]
- ※ Weight : 100g max (with chassis and cover : 210g max)
- ※ PCB Material / thickness : FR-4 / 1.6mm [0.06]
- ※ Optional chassis and cover material : Galvanizing steel board
- ※ Mounting torque (Mounting hole of chassis) : 1.5N·m max

LHA50F

LH A 50 F -□□ -□

① ② ③ ④ ⑤ ⑥

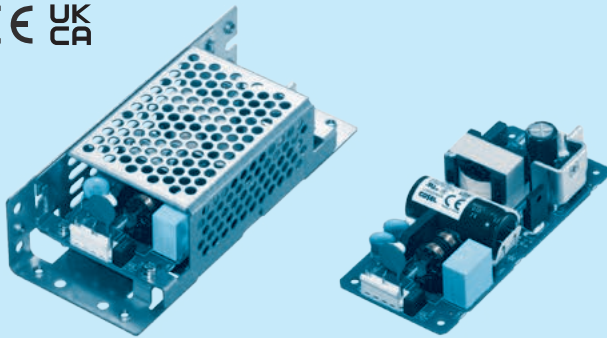

Example recommended EMI/EMC filter
EAC-03-472



High voltage pulse noise type : EAP series
Low leakage current type : EAM series
* A higher current rating EMI/EMC filter may be recommended in view of the other devices that could be connected in parallel with the power supply.

- ① Series name
- ② Single output
- ③ Output wattage
- ④ Universal input
- ⑤ Output voltage
- ⑥ Optional *1
- C : with Coating
- G : Low leakage current
- J4 : EP (TE Connectivity) connector type
- S : with Chassis
- SN : with Chassis & cover
- Y : with Potentiometer

For option details, refer to Instruction Manual 6.

This power supply is manufactured by SMD technology. The stress to PCB like twisting or bending causes the defect of the unit, so handle the unit with care.

*Make sure necessary tests will be carried out on your end equipment with the power supply installed in accordance with any required EMC/EMI regulations.

MODEL	LHA50F-3R3-Y	LHA50F-5	LHA50F-12	LHA50F-15	LHA50F-24	LHA50F-36	LHA50F-48
MAX OUTPUT WATTAGE[W]	*2 26.4	40	51.6	52.5	50.4	50.4	52.8
DC OUTPUT	*2 3.3V8A	5V8A	12V4.3A	15V3.5A	24V2.1A	36V1.4A	48V1.1A

SPECIFICATIONS

	MODEL	LHA50F-3R3-Y	LHA50F-5	LHA50F-12	LHA50F-15	LHA50F-24	LHA50F-36	LHA50F-48		
INPUT	VOLTAGE[VAC]	*2 85 - 264 1 φ (Refer to "Derating" and Instruction Manual 1.1)								
	CURRENT[A]	ACIN 100V	0.56typ	0.82typ	1.05typ					
		ACIN 230V	0.30typ	0.42typ	0.52typ					
	FREQUENCY[Hz]	50 / 60 (45 - 440)								
	EFFICIENCY[%]	ACIN 100V	80.0typ	83.0typ	87.0typ	85.5typ	86.0typ	86.5typ	86.5typ	
		ACIN 230V	83.5typ	86.5typ	90.5typ	89.0typ	89.0typ	90.0typ	90.0typ	
INRUSH CURRENT[A]	ACIN 100V	15typ (Io=100%) Ta=25°C at cold start								
	ACIN 230V	35typ (Io=100%) Ta=25°C at cold start								
LEAKAGE CURRENT[mA]	0.30 / 0.65max (ACIN 100V / 240V 60Hz, Io=100%, According to IEC62368-1 and DEN-AN)									
OUTPUT	VOLTAGE[V]	3.3	5	12	15	24	36	48		
	CURRENT[A]	*2 8.0	8.0	4.3	3.5	2.1	1.4	1.1		
	LINE REGULATION[mV]	*3 20max	20max	48max	60max	96max	144max	192max		
	LOAD REGULATION[mV]	*3 40max	40max	100max	120max	150max	240max	240max		
	RIPPLE[mVp-p]	*4	0 to +50°C	80max	80max	120max	120max	120max	150max	150max
			-10 to 0°C	140max	140max	160max	160max	160max	200max	200max
			Io=0 to 15%	300max	300max	300max	300max	300max	300max	300max
	RIPPLE NOISE[mVp-p]	*4	0 to +50°C	120max	120max	150max	150max	150max	250max	250max
			-10 to 0°C	160max	160max	180max	180max	180max	300max	300max
			Io=0 to 15%	360max	360max	360max	360max	360max	360max	360max
	TEMPERATURE REGULATION[mV]		0 to +50°C	50max	50max	120max	150max	240max	360max	480max
			-10 to +50°C	60max	60max	150max	180max	290max	450max	600max
	DRIFT[mV]	*5	20max	20max	48max	60max	96max	144max	192max	
START-UP TIME[ms]	40typ (ACIN 100V, Io=100%)									
HOLD-UP TIME[ms]	20typ (ACIN 100V, Io=100%) / 140typ (ACIN 230V, Io=100%)									
OUTPUT VOLTAGE ADJUSTMENT RANGE[V]	2.85 to 3.63 Fixed ("Y"option is available for adjusting output voltage between ±10%)									
OUTPUT VOLTAGE SETTING[V]	3.30 to 3.40	4.90 to 5.30	11.50 to 12.50	14.40 to 15.60	23.00 to 25.00	34.50 to 37.50	46.00 to 50.00			
PROTECTION CIRCUIT AND OTHERS	OVERCURRENT PROTECTION	Works over 105% of rating and recovers automatically								
	OVERVOLTAGE PROTECTION	4.00 to 5.25	5.75 to 7.00	13.80 to 16.80	17.25 to 21.00	27.60 to 33.60	41.40 to 50.40	55.20 to 67.20		
	OPERATING INDICATION	Not provided								
	REMOTE SENSING	Not provided								
ISOLATION	INPUT-OUTPUT	AC3,000V 1minute, Cutoff current = 10mA, DC500V 100MΩ min (At Room Temperature)								
	INPUT-FG	AC2,000V 1minute, Cutoff current = 10mA, DC500V 100MΩ min (At Room Temperature)								
	OUTPUT-FG	AC500V 1minute, Cutoff current = 25mA, DC500V 100MΩ min (At Room Temperature)								
ENVIRONMENT	OPERATING TEMP., HUMID. AND ALTITUDE	*2 -10 to +70°C, 20 - 90%RH (Non condensing), 5,000m (16,500feet) max								
	STORAGE TEMP., HUMID. AND ALTITUDE	-20 to +75°C, 20 - 90%RH (Non condensing), 9,000m (30,000feet) max								
	VIBRATION	10 - 55Hz, 19.6m/s ² (2G), 3minutes period, 60minutes each along X, Y and Z axis								
	IMPACT	196.1m/s ² (20G), 11ms, once each X, Y and Z axis								
SAFETY AND NOISE REGULATIONS	AGENCY APPROVALS	UL62368-1, C-UL (equivalent to CAN/CSA-C22.2No.62368-1), EN62368-1, Complies with DEN-AN								
	CONDUCTED NOISE	Complies with FCC-B, VCCI-B, CISPR11-B, CISPR32-B, EN55011-B, EN55032-B								
	HARMONIC ATTENUATOR	*6 Complies with IEC61000-3-2 (Class A) (No built-in power factor correction)								
OTHERS	CASE SIZE/WEIGHT	50 X 27 X 112mm [1.97 X 1.07 X 4.41 inches] (W X H X D) / 140g max (with chassis & cover : 280g max)								
	COOLING METHOD	*2 Convection/Forced air (Requires external fan) (Refer to "Derating")								

*1 The listed options may affect the published standard specifications. Please contact us for detailed product specifications.
 *2 Derating is required.
 *3 At low load conditions, the burst mode operation will start. To check load regulation, you will need to measure the characteristics at average mode with instruments.
 *4 This is the value that measured on measuring board with capacitor of 22 μF and 0.1 μF at 150mm from output terminal. Measured by 20MHz oscilloscope or Ripple-Noise meter (Equivalent to KEISOKU-GIKEN:RM104).
 Ripple and ripple noise spec is change at Io=0 to 15% by burst operation.

*5 Drift is the change in DC output for an eight hour period after a half-hour warm-up at 25°C, with the input voltage held constant at the rated input/output.
 *6 Please contact us about another class. When two or more units are operating it may not comply with the IEC61000-3-2. Please contact us for details.
 * To meet the specification, do not operate overload condition.
 * Parallel operation is not possible.
 * Sound noise may be generated by power supply in case of pulse load.

Block diagram

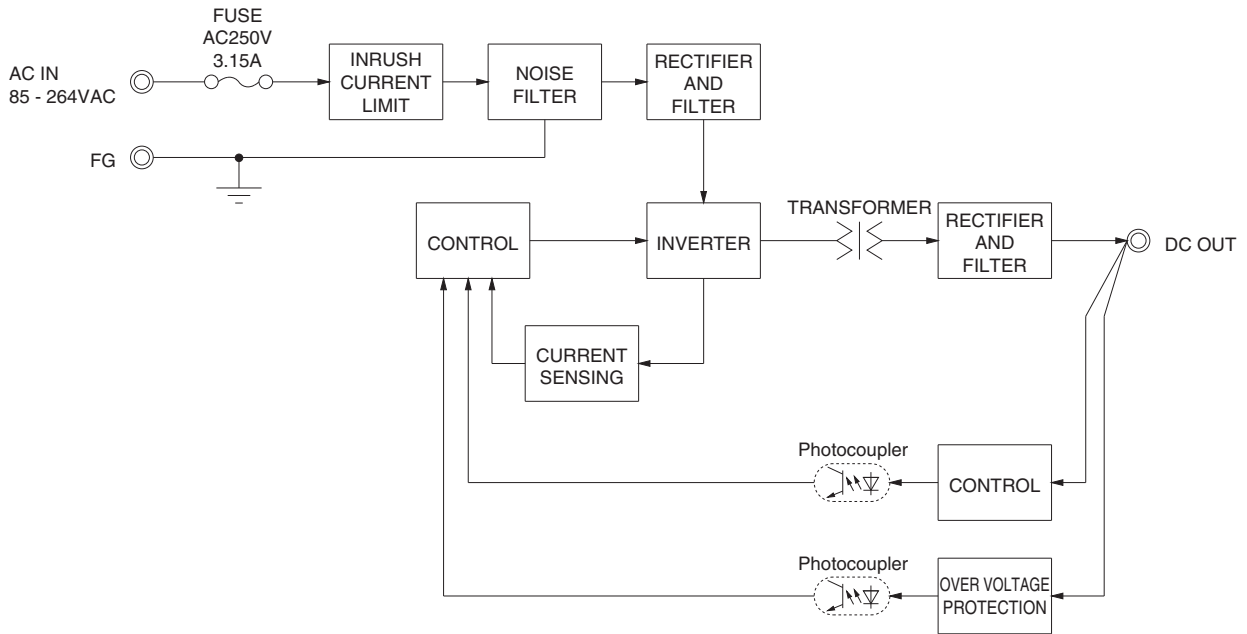

LHA

External view

※ External size of option is different from standard type.

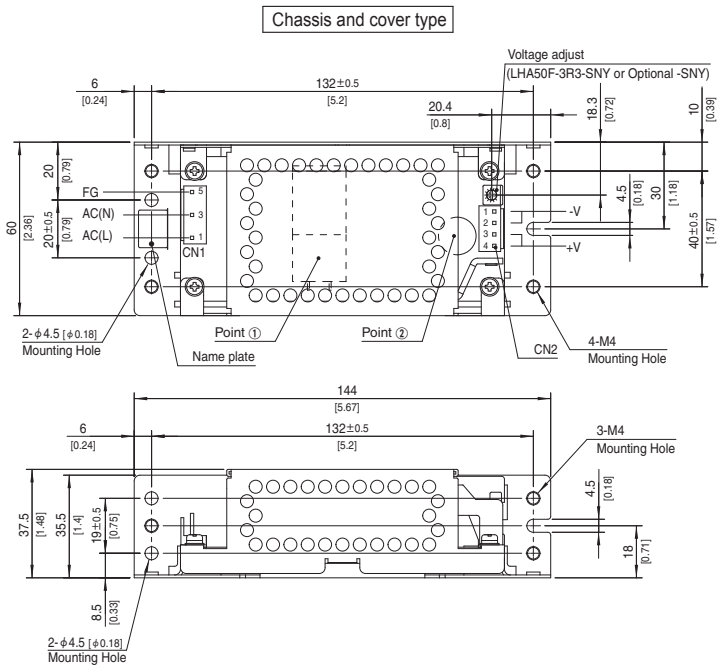
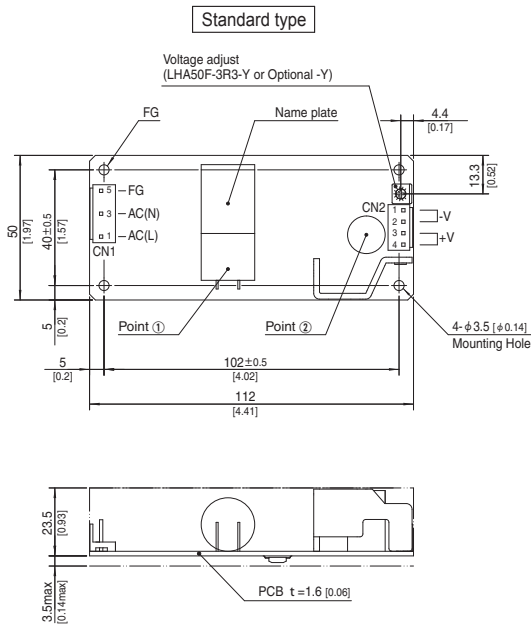

- ※ The back side of PCB of the power supply is assembled some SMDs.
Be careful not to bump against the attached area by vibration.
- ※ Use the spacer of 8mm [0.31] length or more for isolation.
And do not use press-fitting bush.
- ※ Point ①, Point ② are thermometry points. Please refer to Instruction Manual 3.

I/O Connector	Mating connector	Terminal
CN1	B3P5-VH	Chain SVH-21T-P1.1
		Loose BVH-21T-P1.1
CN2	B4P-VH	Chain SVH-21T-P1.1
		Loose BVH-21T-P1.1

(Mfr: J.S.T.)

- ※ I/O Connector is Mfr. J.S.T.
- ※ Option: -J4:EP (TE Connectivity) connector type.

Pin No.	Input
1	AC(L)
2	
3	AC(N)
4	
5	FG

Pin No.	Output
1, 2	-V
3, 4	+V

- ※ Pin No.2 and 4 is NC at CN1.
- ※ Keep drawing current per pin below 5A for CN2.

- ※ Dimensions in mm, []=inches
- ※ Tolerance : ±1 [±0.04]
- ※ Weight : 140g max (with chassis and cover : 280g max)
- ※ PCB Material / thickness : FR-4 / 1.6mm [0.06]
- ※ Optional chassis and cover material : Galvanizing steel board
- ※ Mounting torque (Mounting hole of chassis) : 1.5N·m max

LHA75F

LH A 75 F -□□ -□

① ② ③ ④ ⑤ ⑥

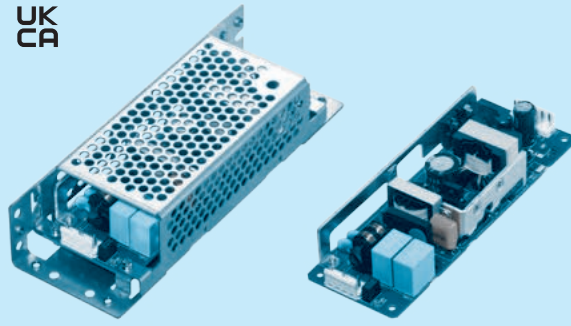

Example recommended EMI/EMC filter
EAC-03-472



High voltage pulse noise type : EAP series
Low leakage current type : EAM series
* A higher current rating EMI/EMC filter may be recommended in view of the other devices that could be connected in parallel with the power supply.

- ① Series name
- ② Single output
- ③ Output wattage
- ④ Universal input
- ⑤ Output voltage
- ⑥ Optional *1
- C : with Coating
- G : Low leakage current
- J4 : EP (TE Connectivity) connector type
- S : with Chassis
- SN : with Chassis & cover
- Y : with Potentiometer

For option details, refer to Instruction Manual 6.

This power supply is manufactured by SMD technology. The stress to PCB like twisting or bending causes the defect of the unit, so handle the unit with care.
* Make sure necessary tests will be carried out on your end equipment with the power supply installed in accordance with any required EMC/EMI regulations.

MODEL	LHA75F-3R3-Y	LHA75F-5	LHA75F-12	LHA75F-15	LHA75F-24	LHA75F-36	LHA75F-48
MAX OUTPUT WATTAGE[W]	*2 39.6	60	75.6	75	76.8	75.6	76.8
DC OUTPUT	*2 3.3V12A	5V12A	12V6.3A	15V5A	24V3.2A	36V2.1A	48V1.6A

SPECIFICATIONS

	MODEL	LHA75F-3R3-Y	LHA75F-5	LHA75F-12	LHA75F-15	LHA75F-24	LHA75F-36	LHA75F-48	
INPUT	VOLTAGE[VAC]	*2 85 - 264 1 φ (Refer to "Derating" and Instruction Manual 1.1)							
	CURRENT[A]	ACIN 100V	0.6typ	0.8typ	0.9typ				
		ACIN 230V	0.3typ	0.4typ	0.5typ				
	FREQUENCY[Hz]	50 / 60 (45 - 66)							
	EFFICIENCY[%]	ACIN 100V	74.0typ	79.0typ	84.5typ	85.5typ	86.0typ	87.5typ	87.5typ
		ACIN 230V	75.0typ	81.0typ	86.5typ	87.5typ	88.0typ	89.5typ	89.5typ
	POWER FACTOR (Io=100%)	ACIN 100V	0.96typ	0.97typ					
ACIN 230V		0.70typ	0.80typ						
INRUSH CURRENT[A]	ACIN 100V	15typ (Io=100%) Ta=25°C at cold start							
	ACIN 230V	35typ (Io=100%) Ta=25°C at cold start							
LEAKAGE CURRENT[mA]	0.40 / 0.75max (ACIN 100V / 240V 60Hz, Io=100%, According to IEC62368-1 and DEN-AN)								
OUTPUT	VOLTAGE[V]	3.3	5	12	15	24	36	48	
	CURRENT[A]	*2 12.0	12.0	6.3	5.0	3.2	2.1	1.6	
	LINE REGULATION[mV]	*3 20max	20max	48max	60max	96max	144max	192max	
	LOAD REGULATION[mV]	*3 40max	40max	100max	120max	150max	240max	240max	
	RIPPLE[mVp-p]	0 to +50°C *7	80max	80max	120max	120max	120max	150max	150max
		-10 to 0°C	140max	140max	160max	160max	160max	200max	200max
		Io=0 to 15%	300max	300max	360max	500max	500max	500max	500max
	RIPPLE NOISE[mVp-p]	0 to +50°C *7	120max	120max	150max	150max	150max	250max	250max
		-10 to 0°C	160max	160max	180max	180max	180max	300max	300max
		Io=0 to 15%	360max	360max	400max	600max	600max	600max	600max
	TEMPERATURE REGULATION[mV]	0 to +50°C *7	50max	50max	120max	150max	240max	360max	480max
		-10 to +50°C *7	60max	60max	150max	180max	290max	450max	600max
	DRIFT[mV]	*5 20max	20max	48max	60max	96max	144max	192max	
START-UP TIME[ms]	100typ (ACIN 100V, Io=100%)								
HOLD-UP TIME[ms]	20typ (ACIN 100V, Io=100%)								
OUTPUT VOLTAGE ADJUSTMENT RANGE[V]	2.85 to 3.63	Fixed ("Y" option is available for adjusting output voltage between ±10%)							
OUTPUT VOLTAGE SETTING[V]	3.30 to 3.40	4.90 to 5.30	11.50 to 12.50	14.40 to 15.60	23.00 to 25.00	34.50 to 37.50	46.00 to 50.00		
PROTECTION CIRCUIT AND OTHERS	OVERCURRENT PROTECTION	Works over 105% of rating and recovers automatically							
	OVERVOLTAGE PROTECTION	4.00 to 5.25	5.75 to 7.00	13.80 to 16.80	17.25 to 21.00	27.60 to 33.60	41.40 to 50.40	55.20 to 67.20	
	OPERATING INDICATION	Not provided							
	REMOTE SENSING	Not provided							
ISOLATION	INPUT-OUTPUT	AC3,000V 1minute, Cutoff current = 10mA, DC500V 100MΩ min (At Room Temperature)							
	INPUT-FG	AC2,000V 1minute, Cutoff current = 10mA, DC500V 100MΩ min (At Room Temperature)							
	OUTPUT-FG	AC500V 1minute, Cutoff current = 25mA, DC500V 100MΩ min (At Room Temperature)							
ENVIRONMENT	OPERATING TEMP., HUMID. AND ALTITUDE *2	-10 to +70°C, 20 - 90%RH (Non condensing), 5,000m (16,500feet) max							
	STORAGE TEMP., HUMID. AND ALTITUDE	-20 to +75°C, 20 - 90%RH (Non condensing), 9,000m (30,000feet) max							
	VIBRATION	10 - 55Hz, 19.6m/s ² (2G), 3minutes period, 60minutes each along X, Y and Z axis							
	IMPACT	196.1m/s ² (20G), 11ms, once each X, Y and Z axis							
SAFETY AND NOISE REGULATIONS	AGENCY APPROVALS	UL62368-1, C-UL (equivalent to CAN/CSA-C22.2No.62368-1), EN62368-1, Complies with DEN-AN							
	CONDUCTED NOISE	Complies with FCC-B, VCCI-B, CISPR11-B, CISPR32-B, EN55011-B, EN55032-B							
	HARMONIC ATTENUATOR *6	Complies with IEC61000-3-2 (Class A)							
OTHERS	CASE SIZE/WEIGHT	50 X 27 X 150mm [1.97 X 1.07 X 5.91 inches] (W X H X D) / 190g max (with chassis & cover : 370g max)							
	COOLING METHOD	*2 Convection/Forced air (Requires external fan) (Refer to "Derating")							

*1 The listed options may affect the published standard specifications. Please contact us for detailed product specifications.
 *2 Derating is required.
 *3 At low load conditions, the burst mode operation will start. To check load regulation, you will need to measure the characteristics at average mode with instruments.
 *4 This is the value that measured on measuring board with capacitor of 22 μF and 0.1 μF at 150mm from output terminal. Measured by 20MHz oscilloscope or Ripple-Noise meter (Equivalent to KEISOKU-GIKEN:RM104).

*5 Ripple and ripple noise spec is change at Io=0 to 15% by burst operation.
 Drift is the change in DC output for an eight hour period after a half-hour warm-up at 25°C, with the input voltage held constant at the rated input/output.
 *6 Please contact us about another class.
 *7 3.3V and 5V output product, the maximum temperature of 40°C.
 *8 To meet the specification, do not operate overload condition.
 *9 Parallel operation is not possible.
 *10 Sound noise may be generated by power supply in case of pulse load.

Block diagram

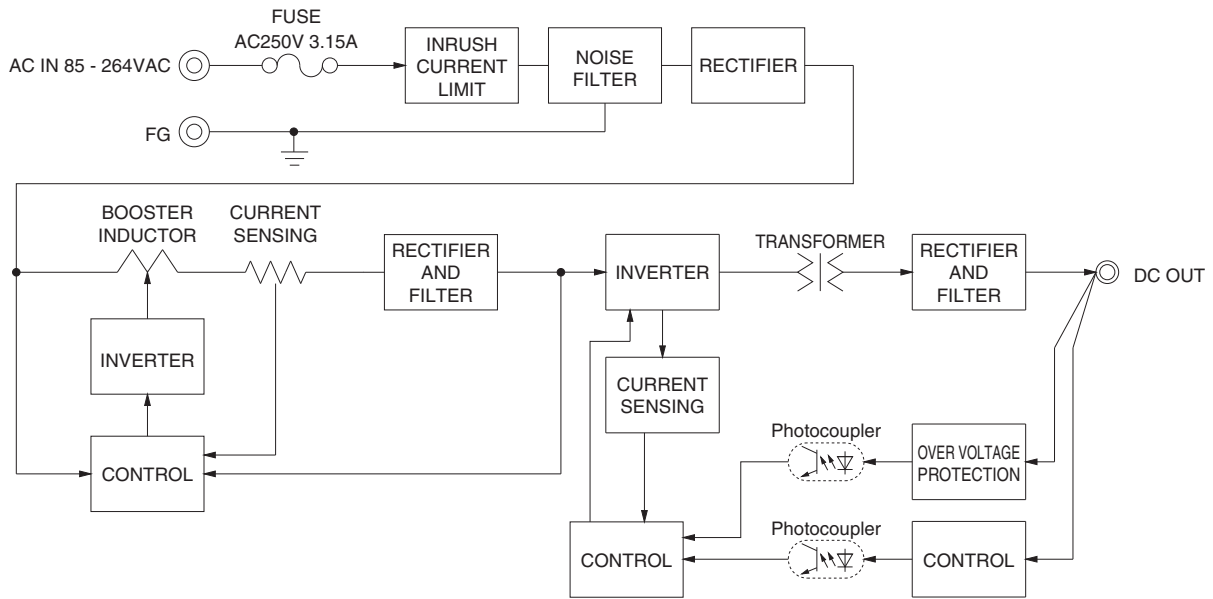

LHA

External view

※ External size of option is different from standard type.

Standard type

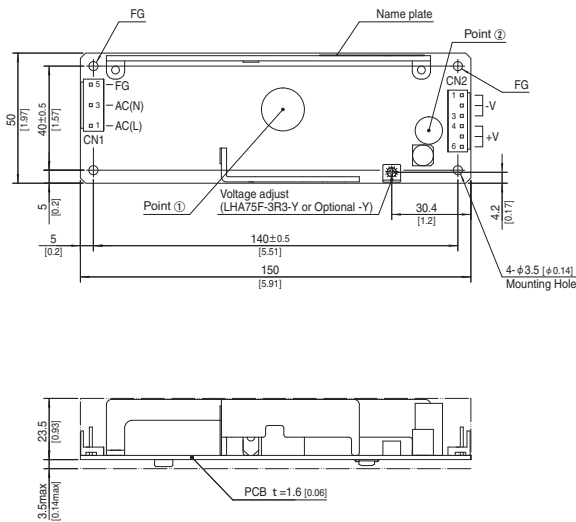

Chassis and cover type

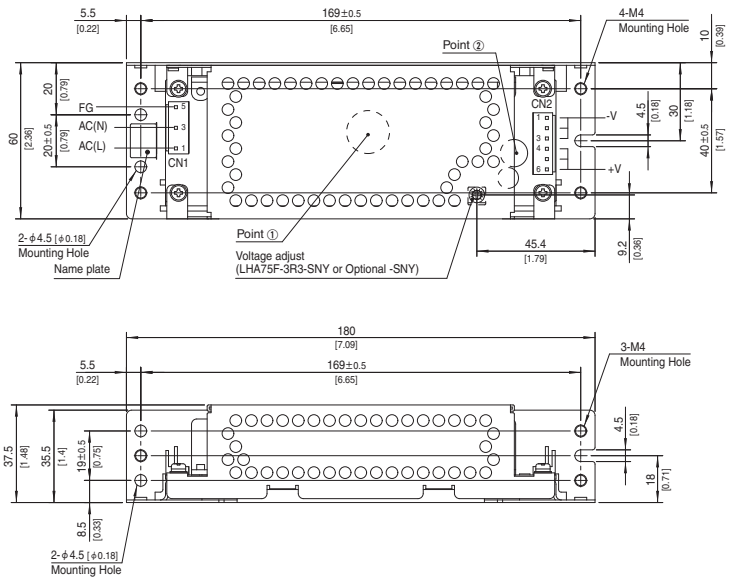

- ※ The back side of PCB of the power supply is assembled some SMDs.
Be careful not to bump against the attached area by vibration.
- ※ Use the spacer of 8mm [0.31] length or more for isolation.
And do not use press-fitting bush.
- ※ Point ①, Point ② are thermometry points. Please refer to Instruction Manual 3.

I/O Connector	Mating connector	Terminal
CN1	B3P5-VH	Chain SVH-21T-P1.1
		Loose BVH-21T-P1.1
CN2	B6P-VH	Chain SVH-21T-P1.1
		Loose BVH-21T-P1.1

(Mfr: J.S.T.)

- ※ I/O Connector is Mfr. J.S.T.
- ※ Option: -J4:EP (TE Connectivity) connector type.

Pin No.	Input
1	AC(L)
2	
3	AC(N)
4	
5	FG

Pin No.	Output
1 to 3	-V
4 to 6	+V

- ※ Pin No.2 and 4 is NC at CN1.
- ※ Keep drawing current per pin below 5A for CN2.

- ※ Dimensions in mm, []=inches
- ※ Tolerance : ±1 [±0.04]
- ※ Weight : 190g max (with chassis and cover : 370g max)
- ※ PCB Material / thickness : FR-4 / 1.6mm [0.06]
- ※ Optional chassis and cover material : Galvanizing steel board
- ※ Mounting torque (Mounting hole of chassis) : 1.5N·m max

LHA100F

LH A 100 F -□□ -□

① ② ③ ④ ⑤ ⑥

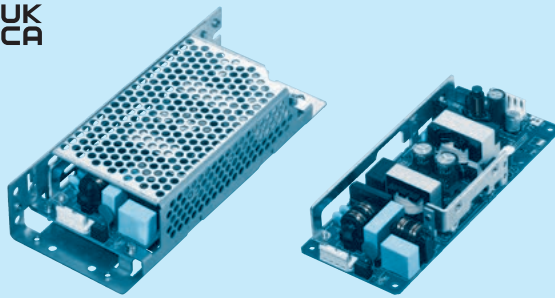

Example recommended EMI/EMC filter EAC-03-472



High voltage pulse noise type : EAP series
Low leakage current type : EAM series
* A higher current rating EMI/EMC filter may be recommended in view of the other devices that could be connected in parallel with the power supply.

- ① Series name
- ② Single output
- ③ Output wattage
- ④ Universal input
- ⑤ Output voltage
- ⑥ Optional *1
- C : with Coating
- G : Low leakage current
- J4 : EP (TE Connectivity) connector type
- R2 : with Remote ON/OFF
- S : with Chassis
- SN : with Chassis & cover
- Y : with Potentiometer

For option details, refer to Instruction Manual 6.

This power supply is manufactured by SMD technology. The stress to PCB like twisting or bending causes the defect of the unit, so handle the unit with care.
* Make sure necessary tests will be carried out on your end equipment with the power supply installed in accordance with any required EMC/EMI regulations.

MODEL	LHA100F-5	LHA100F-12	LHA100F-15	LHA100F-24	LHA100F-36	LHA100F-48
MAX OUTPUT WATTAGE[W]	*2 75	102	100.5	103.2	100.8	100.8
DC OUTPUT	*2 5V15A	12V8.5A	15V6.7A	24V4.3A	36V2.8A	48V2.1A

SPECIFICATIONS

	MODEL	LHA100F-5	LHA100F-12	LHA100F-15	LHA100F-24	LHA100F-36	LHA100F-48	
INPUT	VOLTAGE[VAC]	*2 85 - 264 1 φ (Refer to "Derating" and Instruction Manual 1.1)						
	CURRENT[A]	ACIN 100V	1.0typ	1.2typ				
		ACIN 230V	0.5typ	0.6typ				
	FREQUENCY[Hz]	50 / 60 (45 - 66)						
	EFFICIENCY[%]	ACIN 100V	82.0typ	87.0typ	88.0typ	86.5typ	87.0typ	87.0typ
		ACIN 230V	84.0typ	89.0typ	90.0typ	89.0typ	89.0typ	89.0typ
	POWER FACTOR (Io=100%)	ACIN 100V	0.97typ	0.97typ				
		ACIN 230V	0.83typ	0.87typ				
INRUSH CURRENT[A]	ACIN 100V	15typ (Io=100%) Ta=25°C at cold start						
	ACIN 230V	35typ (Io=100%) Ta=25°C at cold start						
LEAKAGE CURRENT[mA]	0.40 / 0.75max (ACIN 100V / 240V 60Hz, Io=100%, According to IEC62368-1 and DEN-AN)							
OUTPUT	VOLTAGE[V]	5	12	15	24	36	48	
	CURRENT[A]	*2 15.0	8.5	6.7	4.3	2.8	2.1	
	LINE REGULATION[mV]	*3 20max	48max	60max	96max	144max	192max	
	LOAD REGULATION[mV]	*3 40max	100max	120max	150max	240max	240max	
	RIPPLE[mVp-p]	0 to +50°C *7	80max	120max	120max	120max	150max	150max
		-10 to 0°C	140max	160max	160max	160max	200max	200max
		Io=0 to 15%	300max	360max	500max	500max	500max	500max
	RIPPLE NOISE[mVp-p]	0 to +50°C *7	120max	150max	150max	150max	250max	250max
		-10 to 0°C	160max	180max	180max	180max	300max	300max
		Io=0 to 15%	360max	400max	600max	600max	600max	600max
	TEMPERATURE REGULATION[mV]	0 to +50°C *7	50max	120max	150max	240max	360max	480max
		-10 to +50°C *7	60max	150max	180max	290max	450max	600max
	DRIFT[mV]	*5 20max	48max	60max	96max	144max	192max	
	START-UP TIME[ms]	100typ (ACIN 100V, Io=100%)						
	HOLD-UP TIME[ms]	20typ (ACIN 100V, Io=100%)						
OUTPUT VOLTAGE ADJUSTMENT RANGE[V]	Fixed ("Y"option is available for adjusting output voltage between ±10%)							
OUTPUT VOLTAGE SETTING[V]	4.90 to 5.30	11.50 to 12.50	14.40 to 15.60	23.00 to 25.00	34.50 to 37.50	46.00 to 50.00		
PROTECTION CIRCUIT AND OTHERS	OVERCURRENT PROTECTION	Works over 105% of rating and recovers automatically						
	OVERVOLTAGE PROTECTION	5.75 to 7.00	13.80 to 16.80	17.25 to 21.00	27.60 to 33.60	41.40 to 50.40	55.20 to 67.20	
	OPERATING INDICATION	Not provided						
	REMOTE SENSING	Not provided						
	REMOTE CONTROL (RC)	Option (Refer to Instruction Manual 6.1)						
ISOLATION	INPUT-OUTPUT-RC	*8 AC3,000V 1minute, Cutoff current = 10mA, DC500V 100MΩ min (At Room Temperature)						
	INPUT-FG	AC2,000V 1minute, Cutoff current = 10mA, DC500V 100MΩ min (At Room Temperature)						
	OUTPUT-RC-FG	*8 AC500V 1minute, Cutoff current = 25mA, DC500V 100MΩ min (At Room Temperature)						
	OUTPUT-RC	*8 AC100V 1minute, Cutoff current = 25mA, DC100V 10MΩ min (At Room Temperature)						
ENVIRONMENT	OPERATING TEMP., HUMID. AND ALTITUDE	*2 -10 to +70°C, 20 - 90%RH (Non condensing), 5,000m (16,500feet) max						
	STORAGE TEMP., HUMID. AND ALTITUDE	-20 to +75°C, 20 - 90%RH (Non condensing), 9,000m (30,000feet) max						
	VIBRATION	10 - 55Hz, 19.6m/s ² (2G), 3minutes period, 60minutes each along X, Y and Z axis						
	IMPACT	196.1m/s ² (20G), 11ms, once each X, Y and Z axis						
SAFETY AND NOISE REGULATIONS	AGENCY APPROVALS	UL62368-1, C-UL (equivalent to CAN/CSA-C22.2No.62368-1), EN62368-1, Complies with DEN-AN						
	CONDUCTED NOISE	Complies with FCC-B, VCCI-B, CISPR11-B, CISPR32-B, EN55011-B, EN55032-B						
	HARMONIC ATTENUATOR	*6 Complies with EN61000-3-2 (Class A)						
OTHERS	CASE SIZE/WEIGHT	62 X 27 X 155mm [2.44 X 1.07 X 6.10 inches] (W X H X D) / 250g max (with chassis & cover : 450g max)						
	COOLING METHOD	*2 Convection/Forced air (Requires external fan) (Refer to "Derating")						

*1 The listed options may affect the published standard specifications. Please contact us for detailed product specifications.
*2 Derating is required.
*3 At low load conditions, the burst mode operation will start. To check load regulation, you will need to measure the characteristics at average mode with instruments.
*4 This is the value that measured on measuring board with capacitor

of 22 μF and 0.1 μF at 150mm from output terminal. Measured by 20MHz oscilloscope or Ripple-Noise meter (Equivalent to KEISOKU-GIKEN:RM104).
Ripple and ripple noise spec is change at Io=0 to 15% by burst operation.
*5 Drift is the change in DC output for an eight hour period after a half-hour warm-up at 25°C, with the input voltage held constant at the rated input/output.

*6 Please contact us about another class.
*7 5V output product, the maximum temperature of 40°C.
*8 Applicable when Remote ON/OFF (optional) is added.
* To meet the specification, do not operate overload condition.
* Parallel operation is not possible.
* Sound noise may be generated by power supply in case of pulse load.

Block diagram

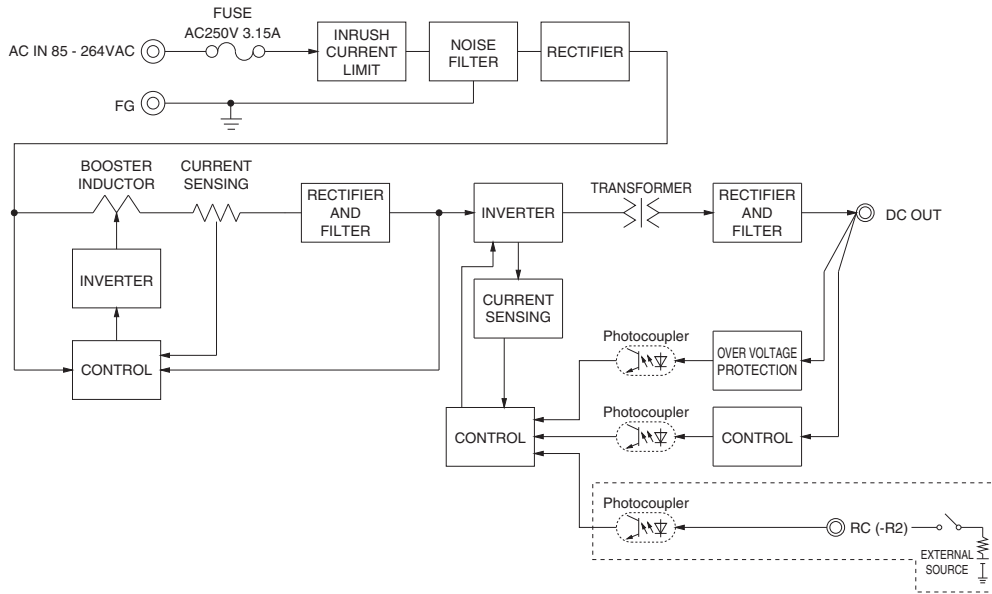

LHA

External view

※ External size of option is different from standard type.

Standard type

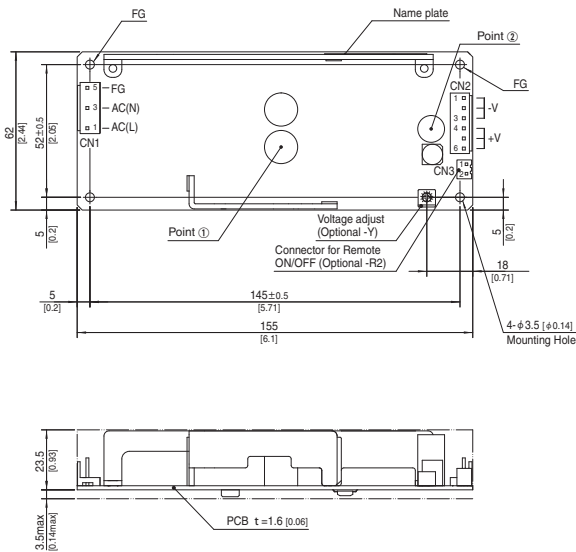

Chassis and cover type

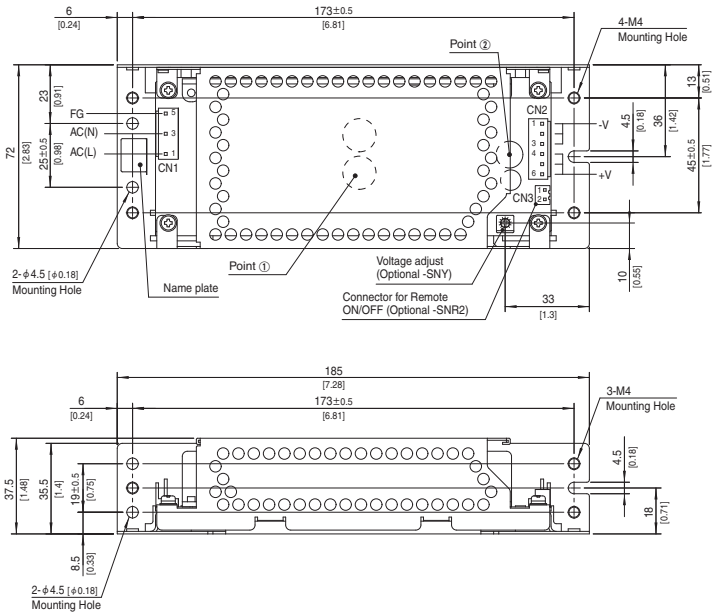

- ※ The back side of PCB of the power supply is assembled some SMDs.
Be careful not to bump against the attached area by vibration.
- ※ Use the spacer of 8mm [0.31] length or more for isolation.
And do not use press-fitting bush.
- ※ Point ①, Point ② are thermometry points. Please refer to Instruction Manual 3.

I/O Connector	Mating connector	Terminal
CN1	B3P5-VH	Chain SVH-21T-P1.1
		Loose BVH-21T-P1.1
CN2	B6P-VH	Chain SVH-21T-P1.1
		Loose BVH-21T-P1.1

(Mfr: J.S.T.)

- ※ I/O Connector is Mfr. J.S.T.
- ※ Option: -J4:EP (TE Connectivity) connector type.

- ※ Dimensions in mm, []=inches
- ※ Tolerance : ±1 [±0.04]
- ※ Weight : 250g max (with chassis and cover : 450g max)
- ※ PCB Material / thickness : FR-4 / 1.6mm [0.06]
- ※ Optional chassis and cover material : Galvanizing steel board
- ※ Mounting torque (Mounting hole of chassis) : 1.5N·m max

Pin No.	Input
1	AC(L)
2	
3	AC(N)
4	
5	FG

- ※ Pin No.2 and 4 is NC at CN1.
- ※ Keep drawing current per pin below 5A for CN2.

Pin No.	Output
1 to 3	-V
4 to 6	+V

CN3 Option (Mfr: J.S.T.)

PIN No.	Contents
1	RC(+)
2	RC(-)

Model B2B-XH-A
Mating Connector (Terminal)
XHP-2

(BXH-001T-P0.6
or SXH-001T-P0.6)

LHA150F

LH A 150 F -□□ -□

① ② ③ ④ ⑤ ⑥

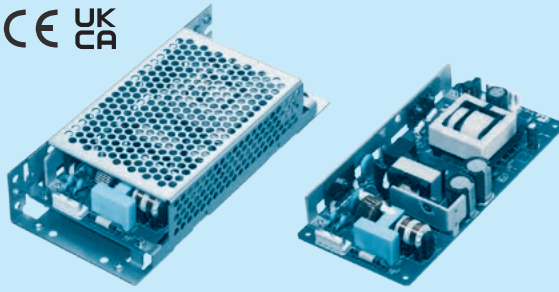
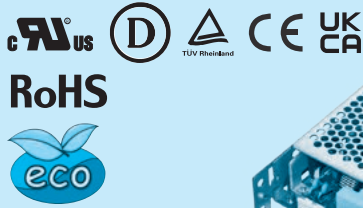

Example recommended EMI/EMC filter EAC-03-472



High voltage pulse noise type : EAP series
Low leakage current type : EAM series
* A higher current rating EMI/EMC filter may be recommended in view of the other devices that could be connected in parallel with the power supply.

- ① Series name
- ② Single output
- ③ Output wattage
- ④ Universal input
- ⑤ Output voltage
- ⑥ Optional *1
- C : with Coating
- G : Low leakage current
- J4 : EP (TE Connectivity) connector type
- R2 : with Remote ON/OFF
- S : with Chassis
- SN : with Chassis & cover
- U1 : Can be attached the external capacitor unit
- Y : with Potentiometer

LHA

This power supply is manufactured by SMD technology. The stress to PCB like twisting or bending causes the defect of the unit, so handle the unit with care.
* Make sure necessary tests will be carried out on your end equipment with the power supply installed in accordance with any required EMC/EMI regulations.

For option details, refer to Instruction Manual 6.

MODEL	LHA150F-12	LHA150F-24	LHA150F-36	LHA150F-48
MAX OUTPUT WATTAGE[W]	150	151.2	151.2	153.6
DC OUTPUT	12V 12.5A	24V 6.3A	36V 4.2A	48V 3.2A

SPECIFICATIONS

	MODEL	LHA150F-12	LHA150F-24	LHA150F-36	LHA150F-48	
INPUT	VOLTAGE[VAC]	85 - 264 1 φ (Refer to "Derating" and Instruction Manual 1.1)				
	CURRENT[A]	ACIN 100V	1.8typ			
		ACIN 230V	0.8typ			
	FREQUENCY[Hz]	50 / 60 (45 - 66)				
	EFFICIENCY[%]	ACIN 100V	86.5typ	89.0typ	89.5typ	90.0typ
		ACIN 230V	89.5typ	92.0typ	92.5typ	93.0typ
	POWER FACTOR (lo=100%)	ACIN 100V	0.99typ			
ACIN 230V		0.91typ				
INRUSH CURRENT[A]	ACIN 100V	15typ (lo=100%) Ta=25°C at cold start				
	ACIN 230V	35typ (lo=100%) Ta=25°C at cold start				
LEAKAGE CURRENT[mA]	0.40 / 0.75max (ACIN 100V / 240V 60Hz, lo=100%, According to IEC62368-1 and DEN-AN)					
OUTPUT	VOLTAGE[V]	12	24	36	48	
	CURRENT[A]	12.5	6.3	4.2	3.2	
	LINE REGULATION[mV]	48max	96max	144max	192max	
	LOAD REGULATION[mV]	100max	150max	240max	240max	
	RIPPLE[mVp-p]	0 to +50°C	120max	120max	150max	150max
		-10 to 0°C	160max	160max	200max	200max
		lo=0 to 10%	160max	160max	200max	200max
	RIPPLE NOISE[mVp-p]	0 to +50°C	150max	150max	250max	250max
		-10 to 0°C	180max	180max	300max	300max
		lo=0 to 10%	230max	230max	300max	300max
	TEMPERATURE REGULATION[mV]	0 to +50°C	120max	240max	360max	480max
		-10 to +50°C	150max	290max	450max	600max
	DRIFT[mV]	48max	96max	144max	192max	
	START-UP TIME[ms]	700typ (ACIN 100V, lo=100%)				
HOLD-UP TIME[ms]	20typ (ACIN 100V, lo=100%)					
OUTPUT VOLTAGE ADJUSTMENT RANGE[V]	Fixed ("Y" option is available for adjusting output voltage between +10%, -5%)					
OUTPUT VOLTAGE SETTING[V]	11.50 to 12.50	23.00 to 25.00	34.50 to 37.50	46.00 to 50.00		
PROTECTION CIRCUIT AND OTHERS	OVERCURRENT PROTECTION	Works over 105% of rating and recovers automatically				
	OVERVOLTAGE PROTECTION	13.80 to 16.80	27.60 to 33.60	41.40 to 50.40	55.20 to 67.20	
	OPERATING INDICATION	Not provided				
	REMOTE SENSING	Not provided				
REMOTE ON/OFF	Option (Refer to Instruction Manual 6.1)					
ISOLATION	INPUT-OUTPUT-RC	AC3,000V 1minute, Cutoff current = 10mA, DC500V 100MΩ min (At Room Temperature)				
	INPUT-FG	AC2,000V 1minute, Cutoff current = 10mA, DC500V 100MΩ min (At Room Temperature)				
	OUTPUT-RC-FG	AC500V 1minute, Cutoff current = 25mA, DC500V 100MΩ min (At Room Temperature)				
	OUTPUT-RC	AC100V 1minute, Cutoff current = 25mA, DC100V 10MΩ min (At Room Temperature)				
ENVIRONMENT	OPERATING TEMP., HUMID. AND ALTITUDE	-10 to +70°C, 20 - 90%RH (Non condensing), 5,000m (16,500feet) max (EN62477-1 (OVC III) : 2,000m (6,600feet) max)				
	STORAGE TEMP., HUMID. AND ALTITUDE	-20 to +75°C, 20 - 90%RH (Non condensing), 9,000m (30,000feet) max				
	VIBRATION	10 - 55Hz, 19.6m/s ² (2G), 3minutes period, 60minutes each along X, Y and Z axis				
	IMPACT	196.1m/s ² (20G), 11ms, once each X, Y and Z axis				
SAFETY AND NOISE REGULATIONS	AGENCY APPROVALS	UL62368-1, C-UL (equivalent to CAN/CSA-C22.2 No.62368-1), EN62368-1, EN62477-1 (OVC III), Complies with DEN-AN				
	CONDUCTED NOISE	Complies with FCC-B, VCCI-B, CISPR11-B, CISPR32-B, EN55011-B, EN55032-B				
OTHERS	HARMONIC ATTENUATOR	Complies with IEC61000-3-2 (Class A)				
OTHERS	CASE SIZE/WEIGHT	75 X 27 X 160mm [2.95 X 1.07 X 6.30 inches] (W X H X D) / 320g max (with chassis & cover : 570g max)				
	COOLING METHOD	Convection/Forced air (Requires external fan) (Refer to "Derating")				

*1 The listed options may affect the published standard specifications. Please contact us for detailed product specifications.

*2 Derating is required.

*3 At low load conditions, the burst mode operation will start. To check load regulation, you will need to measure the characteristics at average mode with instruments.

*4 This is the value that measured on measuring board with capacitor of 22 μF and 0.1 μF at 150mm from output terminal. Measured

by 20MHz oscilloscope or Ripple-Noise meter (Equivalent to KEISOKU-GIKEN:RM104).
Ripple and ripple noise spec is change at lo=0 to 10% by burst operation.

*5 Drift is the change in DC output for an eight hour period after a half-hour warm-up at 25°C, with the input voltage held constant at the rated input/output.

*6 Please contact us about another class.

*7 12V output product, the maximum temperature of 40°C.

*8 Applicable when Remote ON/OFF (optional) is added.

*9 To meet the specification, do not operate overload condition.

*10 Parallel operation is not possible.

*11 Sound noise may be generated by power supply in case of pulse load.

Block diagram

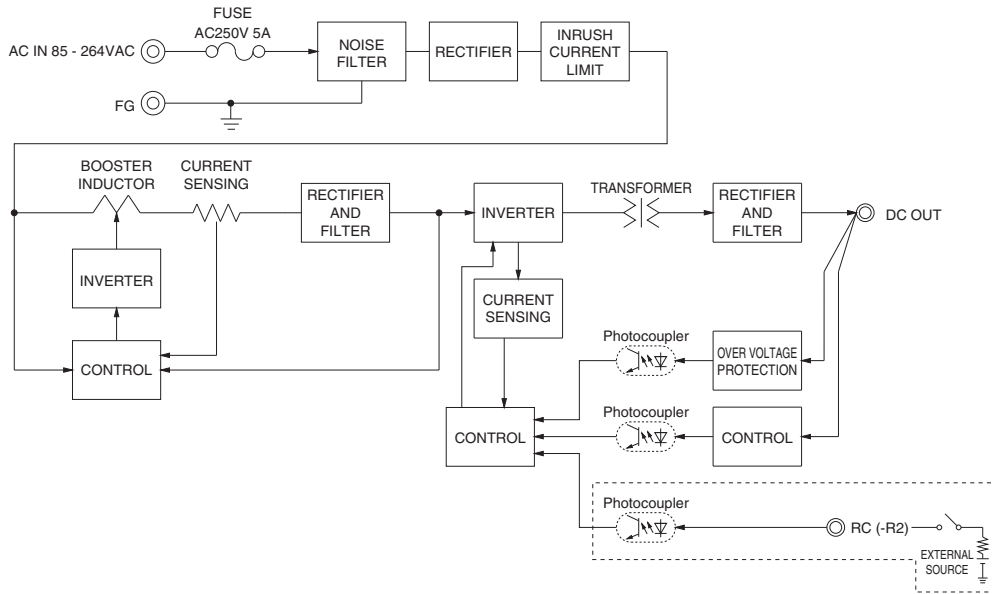

LHA

External view

※ External size of option is different from standard type.

Standard type

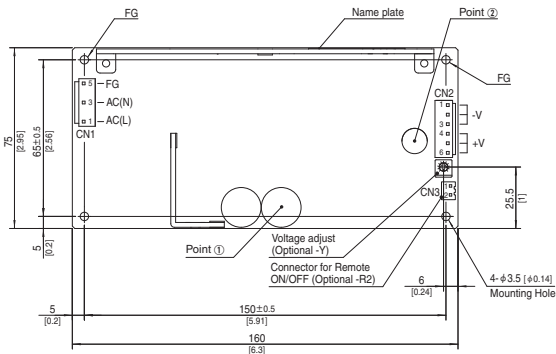

Chassis and cover type

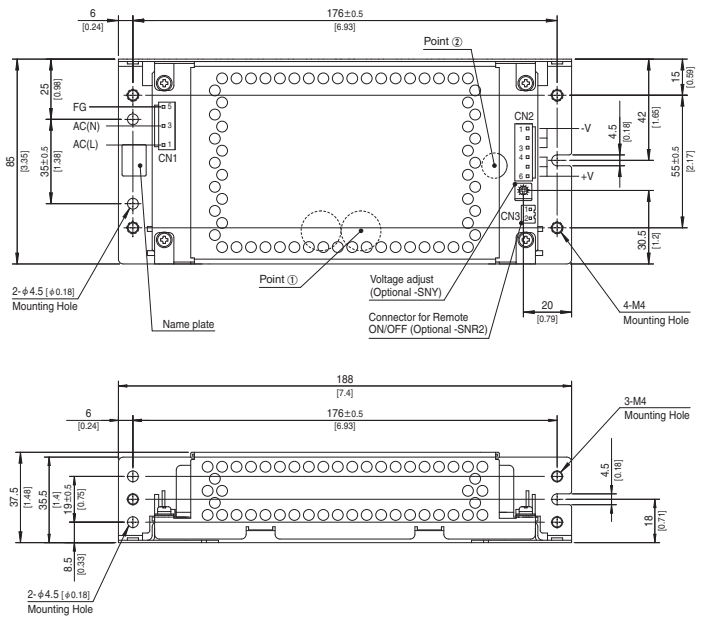

- ※ The back side of PCB of the power supply is assembled some SMDs.
- Be careful not to bump against the attached area by vibration.
- ※ Use the spacer of 8mm [0.31] length or more for isolation.
- And do not use press-fitting bush.
- ※ Point ①, Point ② are thermometry points. Please refer to Instruction Manual 3.

I/O Connector	Mating connector	Terminal	
CN1	B3P5-VH	VHR-5N	Chain SVH-21T-P1.1
			Loose BVH-21T-P1.1
CN2	B6P-VH	VHR-6N	Chain SVH-21T-P1.1
			Loose BVH-21T-P1.1

(Mfr: J.S.T.)

※ I/O Connector is Mfr.J.S.T.

※ Option:-J4:EP (TE Connectivity) connector type.

※ Dimensions in mm, []=inches

※ Tolerance : ±1 [±0.04]

※ Weight : 320g max (with chassis and cover : 570g max)

※ PCB Material / thickness : FR-4 / 1.6mm [0.06]

※ Optional chassis and cover material : Galvanizing steel board

※ Mounting torque (Mounting hole of chassis) : 1.5N·m max

CN1

Pin No.	Input
1	AC(L)
2	
3	AC(N)
4	
5	FG

CN2

Pin No.	Output
1 to 3	-V
4 to 6	+V

CN3 Option (Mfr:J.S.T.)

PIN No.	Contents
1	RC(+)
2	RC(-)

Model B2B-XH-A
Mating Connector (Terminal)
XHP-2

(BXH-001T-P0.6
or SXH-001T-P0.6)

※ Pin No.2 and 4 is NC at CN1.

※ Keep drawing current per pin below 5A for CN2.

LHA300F

LH A 300 F -□□ -□

① ② ③ ④ ⑤ ⑥

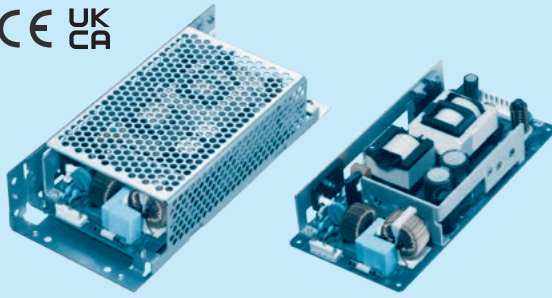
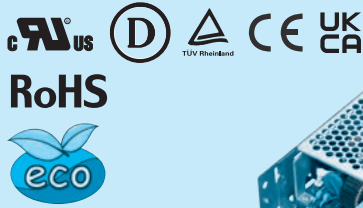

Example recommended EMI/EMC filter
EAC-06-472



High voltage pulse noise type : EAP series
Low leakage current type : EAM series
* A higher current rating EMI/EMC filter may be recommended in view of the other devices that could be connected in parallel with the power supply.

- ① Series name
- ② Single output
- ③ Output wattage
- ④ Universal input
- ⑤ Output voltage
- ⑥ Optional *1
- C : with Coating
- G : Low leakage current
- J4 : EP (TE Connectivity) connector type
- J5 : 8 pin type(Output connector)
- R2 : with Remote ON/OFF
- S : with Chassis
- SN : with Chassis & cover
- T : Terminal block type
- T4 : Push-in Terminal block type
- U1 : Can be attached the external capacitor unit

This power supply is manufactured by SMD technology. The stress to PCB like twisting or bending causes the defect of the unit, so handle the unit with care.

* Make sure necessary tests will be carried out on your end equipment with the power supply installed in accordance with any required EMC/EMI regulations.

For option details, refer to Instruction Manual 6.

MODEL	LHA300F-12-Y	LHA300F-24-Y	LHA300F-48-Y
MAX OUTPUT WATTAGE[W]	300	300	302.4
DC OUTPUT	12V 25A	24V 12.5A	48V 6.3A

SPECIFICATIONS

	MODEL	LHA300F-12-Y	LHA300F-24-Y	LHA300F-48-Y	
INPUT	VOLTAGE[VAC]	*2 85 - 264 1 φ (Refer to "Derating" and Instruction Manual 1.1)			
	CURRENT[A]	ACIN 100V	3.5typ		
		ACIN 230V	1.6typ		
	FREQUENCY[Hz]	50 / 60 (45 - 66)			
	EFFICIENCY[%]	ACIN 100V	90.0typ	91.5typ	92.0typ
		ACIN 230V	92.0typ	93.5typ	94.0typ
	POWER FACTOR (lo=100%)	ACIN 100V	0.99typ		
ACIN 230V		0.93typ			
INRUSH CURRENT[A]	ACIN 100V	20typ (lo=100%) Ta=25°C at cold start			
	ACIN 230V	40typ (lo=100%) Ta=25°C at cold start			
LEAKAGE CURRENT[ma]	0.40 / 0.75max (ACIN 100V / 240V 60Hz, lo=100%, According to IEC62368-1 and DEN-AN)				
OUTPUT	VOLTAGE[V]	12	24	48	
	CURRENT[A]	*2 25.0	12.5	6.3	
	LINE REGULATION[mV]	*3 48max	96max	192max	
	LOAD REGULATION[mV]	*3 100max	150max	240max	
	RIPPLE[mVp-p]	0 to +50°C *7	120max	120max	150max
		-10 to 0°C	160max	160max	200max
		lo=0 to 10%	160max	160max	200max
	RIPPLE NOISE[mVp-p]	0 to +50°C *7	150max	150max	250max
		-10 to 0°C	180max	180max	300max
		lo=0 to 10%	180max	180max	300max
	TEMPERATURE REGULATION[mV]	0 to +50°C *7	120max	240max	480max
		-10 to +50°C *7	150max	290max	600max
	DRIFT[mV]	*5 48max	96max	192max	
	START-UP TIME[ms]	700typ (ACIN 100V, lo=100%)			
HOLD-UP TIME[ms]	25typ (ACIN 100V, lo=100%)				
OUTPUT VOLTAGE ADJUSTMENT RANGE[V]	11.40 to 13.20		22.80 to 26.40		
OUTPUT VOLTAGE SETTING[V]	12.00 to 12.48		24.00 to 24.96		
PROTECTION CIRCUIT AND OTHERS	OVERCURRENT PROTECTION	Works over 105% of rating and recovers automatically			
	OVERVOLTAGE PROTECTION	13.80 to 16.80	27.60 to 33.60	55.20 to 67.20	
	OPERATING INDICATION	Not provided			
	REMOTE SENSING	Not provided			
	REMOTE ON/OFF	Option (Refer to Instruction Manual 6.1)			
ISOLATION	INPUT-OUTPUT-RC	*8 AC3,000V 1minute, Cutoff current = 10mA, DC500V 100MΩ min (At Room Temperature)			
	INPUT-FG	AC2,000V 1minute, Cutoff current = 10mA, DC500V 100MΩ min (At Room Temperature)			
	OUTPUT-RC-FG	*8 AC500V 1minute, Cutoff current = 25mA, DC500V 100MΩ min (At Room Temperature)			
	OUTPUT-RC	*8 AC100V 1minute, Cutoff current = 25mA, DC100V 10MΩ min (At Room Temperature)			
ENVIRONMENT	OPERATING TEMP., HUMID. AND ALTITUDE	*2 -10 to +70°C, 20 - 90%RH (Non condensing), 5,000m (16,500feet) max (EN62477-1 (OVC III) : 2,000m (6,600feet) max)			
	STORAGE TEMP., HUMID. AND ALTITUDE	-20 to +75°C, 20 - 90%RH (Non condensing), 9,000m (30,000feet) max			
	VIBRATION	10 - 55Hz, 19.6m/s ² (2G), 3minutes period, 60minutes each along X, Y and Z axis			
	IMPACT	196.1m/s ² (20G), 11ms, once each X, Y and Z axis			
SAFETY AND NOISE REGULATIONS	AGENCY APPROVALS	UL62368-1, C-UL (equivalent to CAN/CSA-C22.2 No.62368-1), EN62368-1, EN62477-1 (OVC III), Complies with DEN-AN			
	CONDUCTED NOISE	Complies with FCC-B, VCCI-B, CISPR11-B, CISPR32-B, EN55011-B, EN55032-B			
	HARMONIC ATTENUATOR	*6 Complies with IEC61000-3-2 (Class A)			
OTHERS	CASE SIZE/WEIGHT	84 × 37 × 180mm [3.31 × 1.46 × 7.09 inches] (W × H × D) / 580g max (with chassis & cover : 890g max)			
	COOLING METHOD	*2 Convection/Forced air (Requires external fan) (Refer to "Derating")			

*1 The listed options may affect the published standard specifications. Please contact us for detailed product specifications.

*2 Derating is required.

*3 At low load conditions, the burst mode operation will start. To check load regulation, you will need to measure the characteristics at average mode with instruments.

*4 This is the value that measured on measuring board with capacitor of 22 μF and 0.1 μF at 150mm from output terminal. Measured

by 20MHz oscilloscope or Ripple-Noise meter (Equivalent to KEISOKU-GIKEN:RM104)

Ripple and ripple noise spec is change at lo=0 to 10% by burst operation.

*5 Drift is the change in DC output for an eight hour period after a half-hour warm-up at 25°C, with the input voltage held constant at the rated input/output.

*6 Please contact us about another class.

*7 12V output product, the maximum temperature of 35°C.

*8 Applicable when Remote ON/OFF (optional) is added.

To meet the specification, do not operate overload condition.

* Parallel operation is not possible.

* Sound noise may be generated by power supply in case of pulse load.

Block diagram

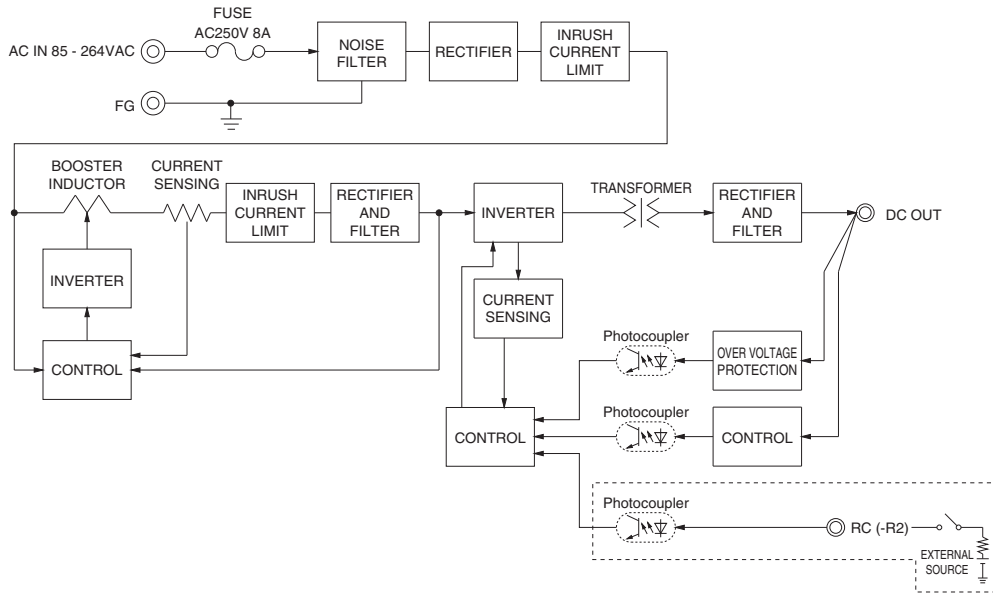

LHA

External view

※ External size of option is different from standard type.

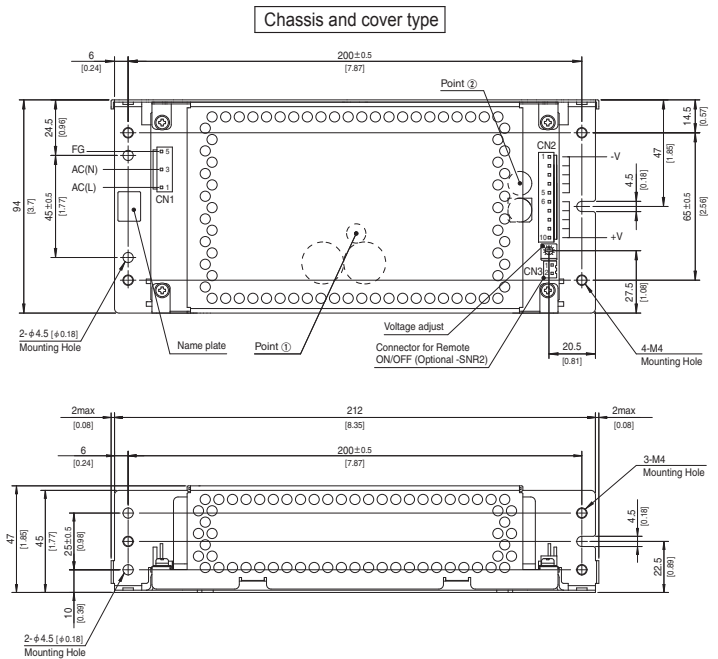
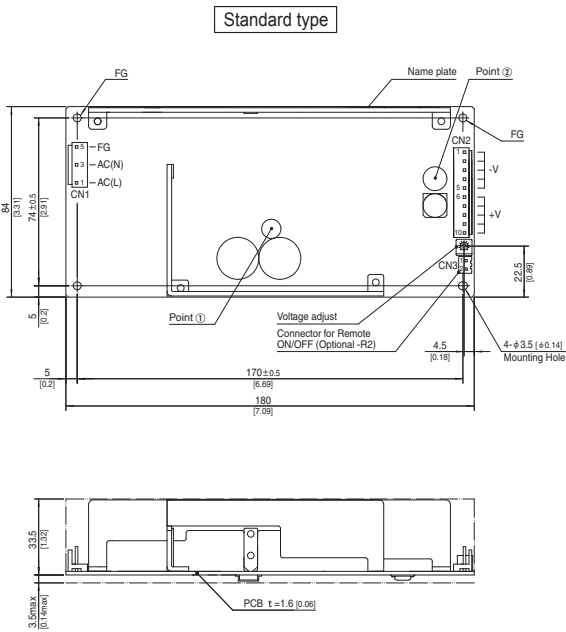

- ※ The back side of PCB of the power supply is assembled some SMDs.
- Be careful not to bump against the attached area by vibration.
- ※ Use the spacer of 8mm [0.31] length or more for isolation.
- And do not use press-fitting bush.
- ※ Point ①, Point ② are thermometry points. Please refer to Instruction Manual 3.

I/O Connector	Mating connector	Terminal
CN1	B3P5-VH	Chain SVH-21T-P1.1
		Loose BVH-21T-P1.1
CN2	B10P-VH	Chain SVH-21T-P1.1
		Loose BVH-21T-P1.1

(Mfr: J.S.T.)

- ※ I/O Connector is Mfr.J.S.T.
- ※ Option:-J4:EP (TE Connectivity) connector type.
- ※ Option:-J5:Output connector as 8 pin type.

- ※ Dimensions in mm, []=inches
- ※ Tolerance : ±1 [±0.04]
- ※ Weight : 580g max (with chassis and cover : 890g max)
- ※ PCB Material / thickness : FR-4 / 1.6mm [0.06]
- ※ Optional chassis and cover material : Galvanizing steel board
- ※ Mounting torque (Mounting hole of chassis) : 1.5N·m max

CN1

Pin No.	Input
1	AC(L)
2	
3	AC(N)
4	FG

- ※ Pin No.2 and 4 is NC at CN1.
- ※ Keep drawing current per pin below 5A for CN2.

CN2

Pin No.	Output
1 to 5	-V
6 to 10	+V

CN3 Option (Mfr:J.S.T.)

PIN No.	Contents
1	RC(+)
2	RC(-)

Model B2B-XH-A
Mating Connector (Terminal)
XHP-2
(BXH-001T-P0.6 or SXH-001T-P0.6)

Assembling and Installation Method

Installation method

■ This power supply is manufactured by SMD technology. Do not touch any SMD components on the unit. Be especially careful when handling.

■ If using a metal chassis, keep proper insulation between the component and metal chassis, use the spacer of 8mm or more between bottom of power supply and metal chassis.

If d_1 and/or d_2 are less than the value mentioned in right figure, insert an insulating sheet with reinforced insulation between the power supply unit and metal chassis.

The following distance is not satisfactory for cooling condition. Please refer to "Derating" and Instruction Manual 3 for cooling method.

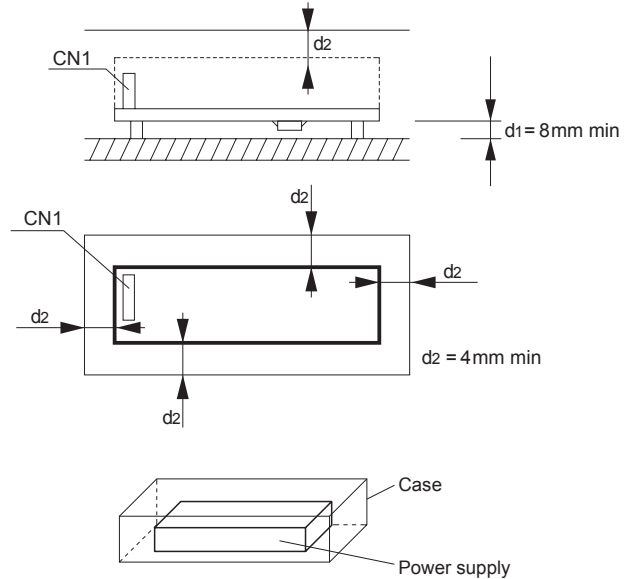

■ There is a possibility that it is not possible to cool enough when the power supply is used by the sealing up space as showing in right figure.

Please use it after confirming the temperature of points ① and points ② of Instruction Manual 3.

■ Installation method shown right is possible.

■ In optional -SN, Method (F) is not available with convection cooling. If method (F) is used, use with forced air cooling or derate temperature / load. For more details, please contact us.

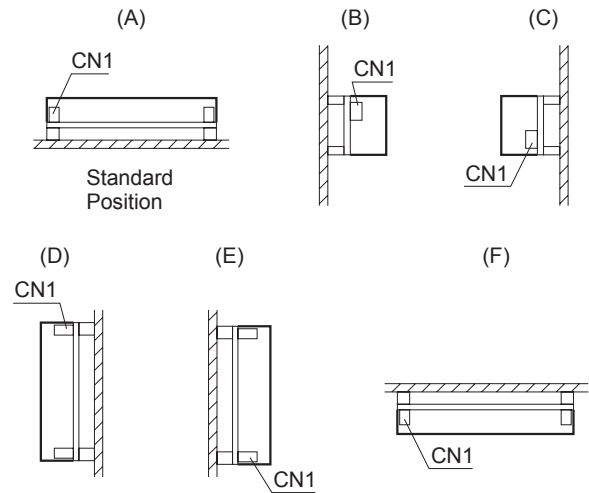

Mounting screw

■ The mounting screw should be $\phi 3\text{mm}$. The hatched area shows the allowance of metal parts for mounting.

● LHA10F, LHA15F, LHA30F

● LHA50F, LHA75F, LHA100F, LHA150F, LHA300F

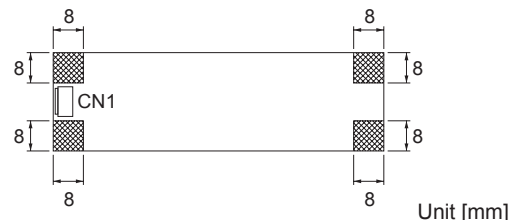
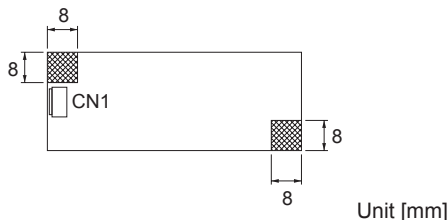

■ If mounting metallic fittings on the board surface, ensure there is no contact with components.

■ This product uses SMD technology. Please avoid the PCB installation method which includes the twisting stress or the bending stress.

Derating

● Derating curve for input voltage

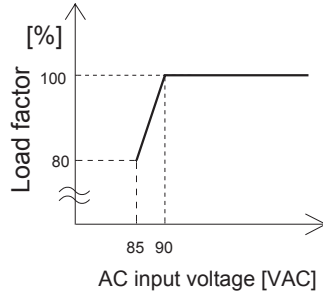

LHA

● LHA10F-3R3-Y,-5,-12
Ambient temperature derating curve
(Reference value)

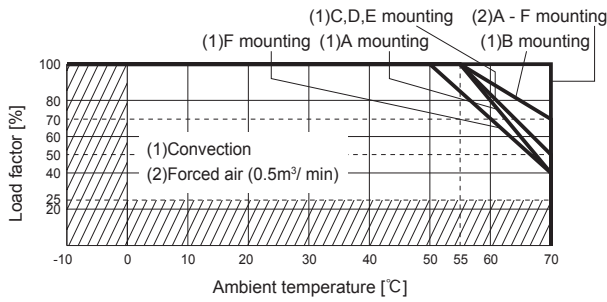

● LHA10F-15,-24
Ambient temperature derating curve
(Reference value)

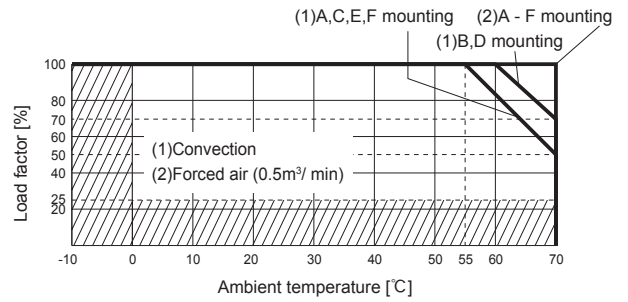

● LHA10F-3R3-SNY,-5-SN,-12-SN
Ambient temperature derating curve
(Reference value)

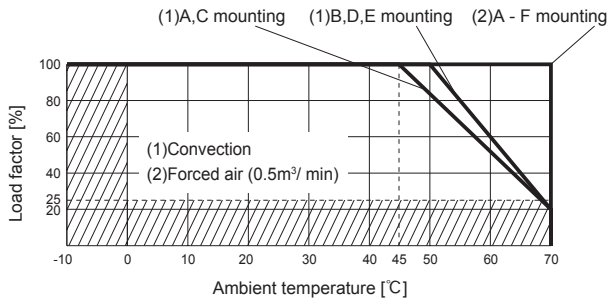

● LHA10F-15-SN,-24-SN
Ambient temperature derating curve
(Reference value)

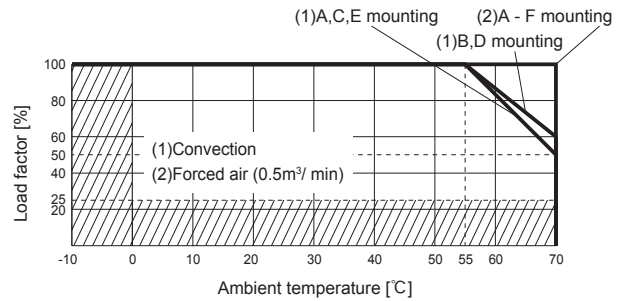

● LHA15F-3R3-Y,-5,-12
Ambient temperature derating curve
(Reference value)

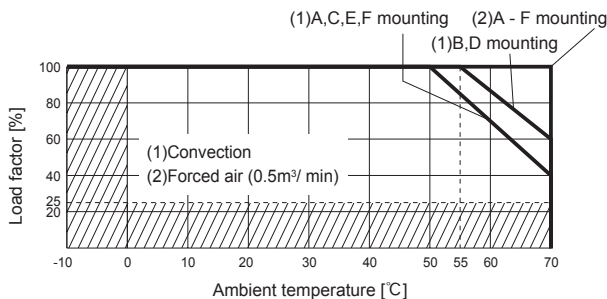

● LHA15F-15,-24
Ambient temperature derating curve
(Reference value)

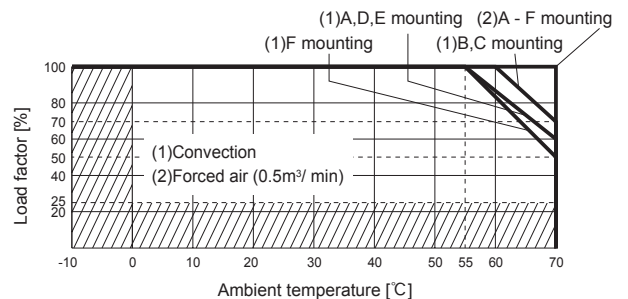

Derating

- LHA15F-3R3-SNY,-5-SN,-12-SN
Ambient temperature derating curve
(Reference value)

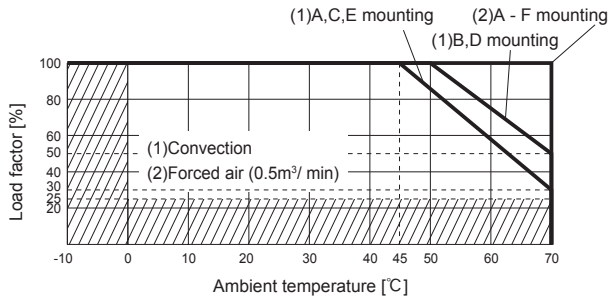

- LHA15F-15-SN,-24-SN
Ambient temperature derating curve
(Reference value)

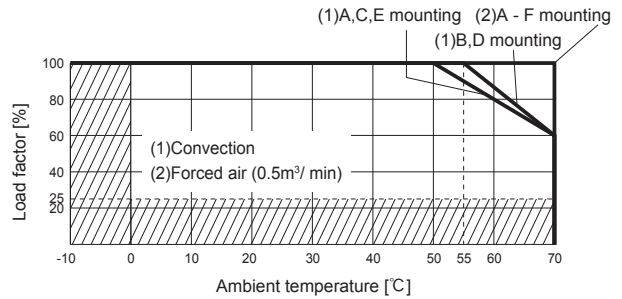

- LHA30F-3R3-Y,-5,-12,-15,-24
Ambient temperature derating curve
(Reference value)

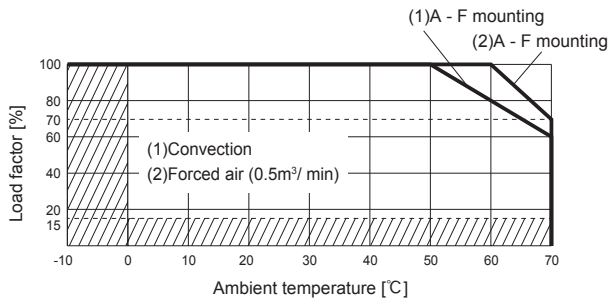

- LHA30F-3R3-SNY,-5-SN,-12-SN,-15-SN,-24-SN
Ambient temperature derating curve
(Reference value)

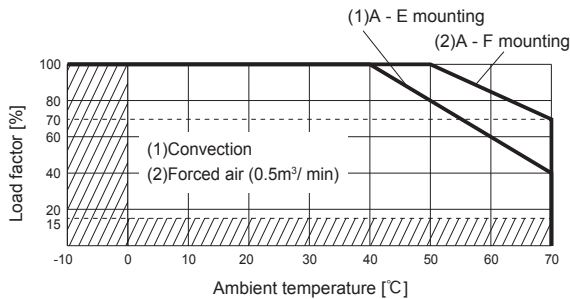

- LHA50F-3R3-Y,-5,-24,-36,-48
Ambient temperature derating curve
(Reference value)

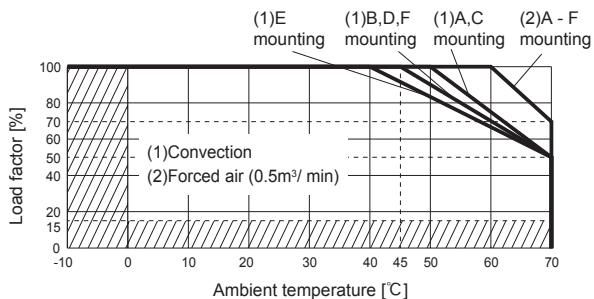

- LHA50F-12,-15
Ambient temperature derating curve
(Reference value)

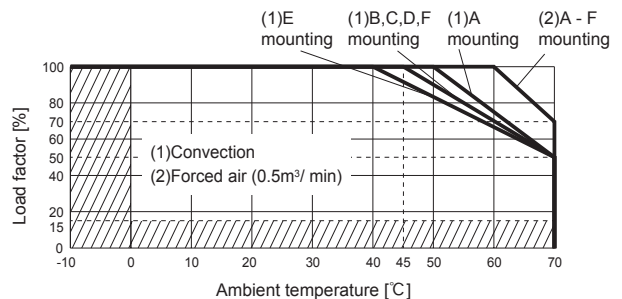

Derating

- LHA50F-3R3-SNY, -12-SN, -24-SN, -36-SN, -48-SN
Ambient temperature derating curve
(Reference value)

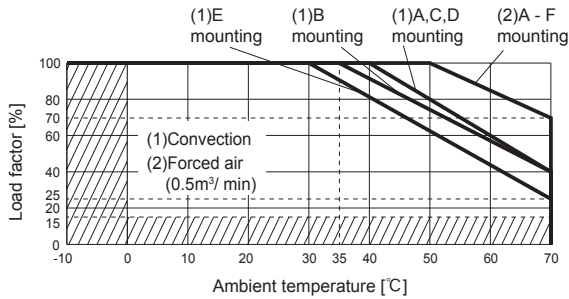

- LHA50F-5-SN, -15-SN
Ambient temperature derating curve
(Reference value)

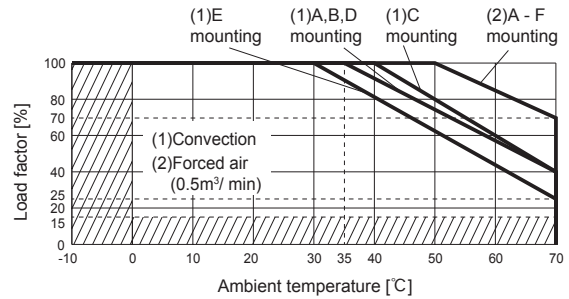

LHA

- LHA75F-3R3-Y, -5
Ambient temperature derating curve
(Reference value)

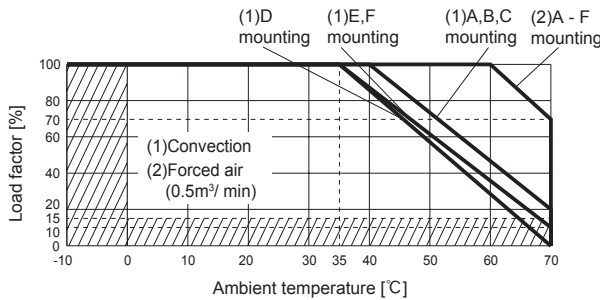

- LHA75F-12, -15, -24, -36, -48
Ambient temperature derating curve
(Reference value)

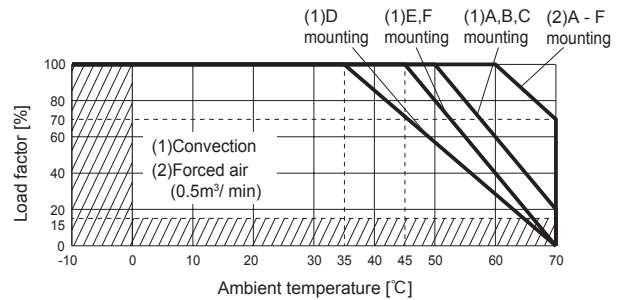

- LHA75F-3R3-SNY, -5-SN
Ambient temperature derating curve
(Reference value)

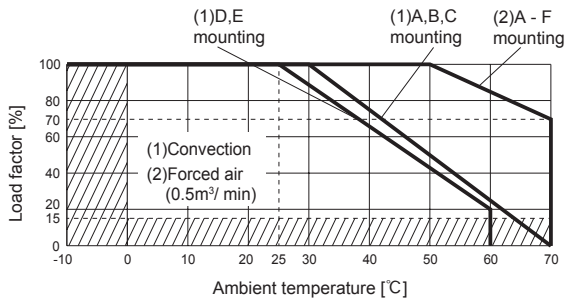

- LHA75F-12-SN, -15-SN, -24-SN, -36-SN, -48-SN
Ambient temperature derating curve
(Reference value)

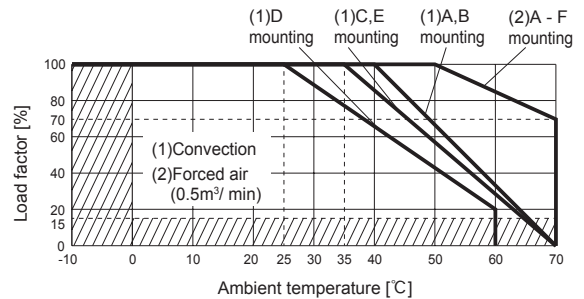

- LHA100F-5
Ambient temperature derating curve
(Reference value)

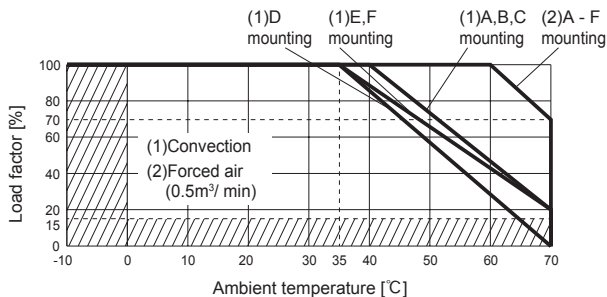

- LHA100F-12, -15, -24, -36, -48
Ambient temperature derating curve
(Reference value)

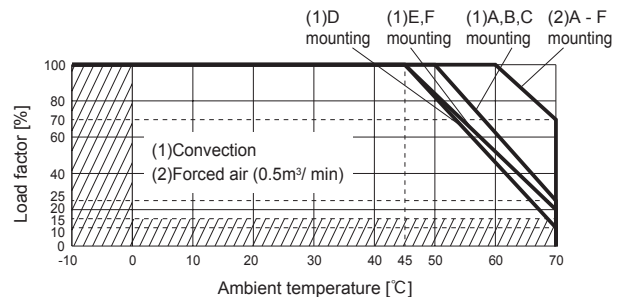

Derating

- LHA100F-5-SN
Ambient temperature derating curve
(Reference value)

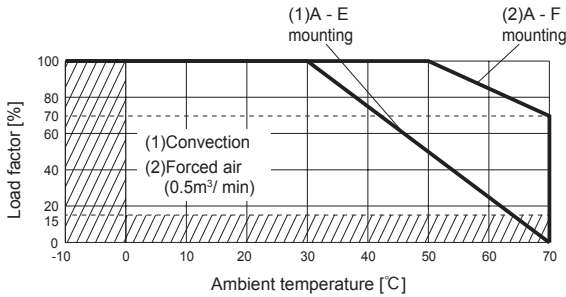

- LHA100F-12-SN,-15-SN,-24-SN,-36-SN,-48-SN
Ambient temperature derating curve
(Reference value)

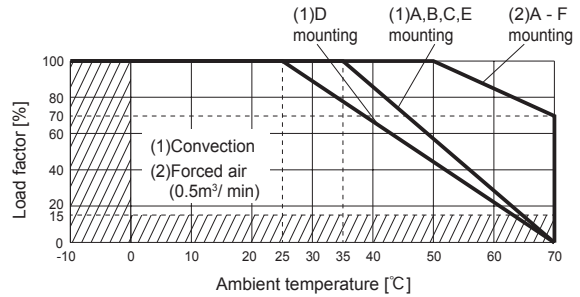

- LHA150F-12
Ambient temperature derating curve
(Reference value)

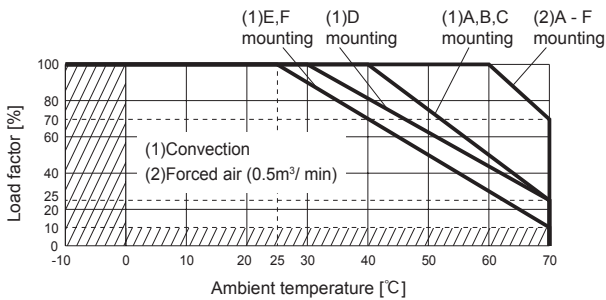

- LHA150F-24, -36, -48
Ambient temperature derating curve
(Reference value)

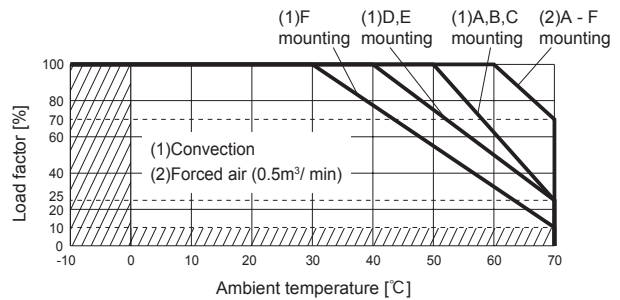

- LHA150F-12-SN
Ambient temperature derating curve
(Reference value)

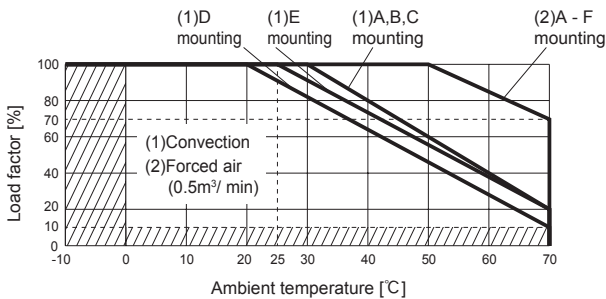

- LHA150F-24-SN, -36-SN, -48-SN
Ambient temperature derating curve
(Reference value)

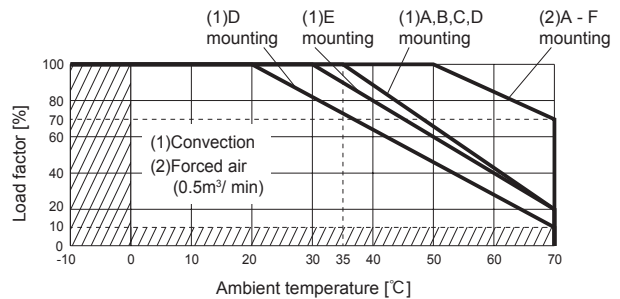

- LHA300F-12-Y
Ambient temperature derating curve
(Reference value)

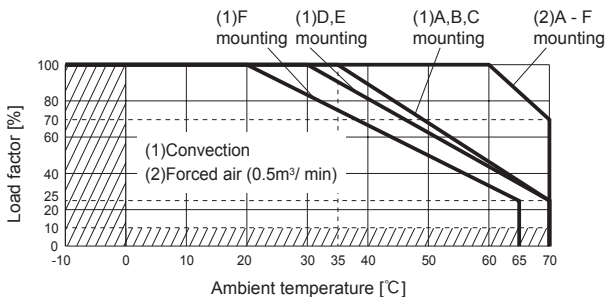

- LHA300F-24-Y, -48-Y
Ambient temperature derating curve
(Reference value)

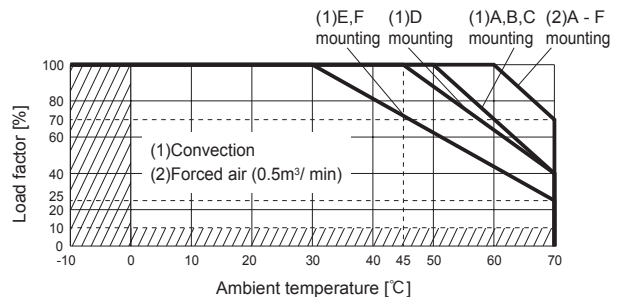

Derating

- LHA300F-12-SNY
Ambient temperature derating curve
(Reference value)

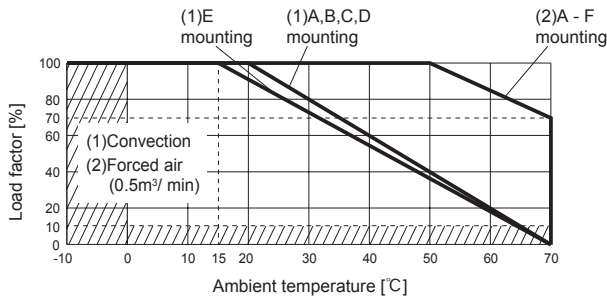

- LHA300F-24-SNY, -48-SNY
Ambient temperature derating curve
(Reference value)

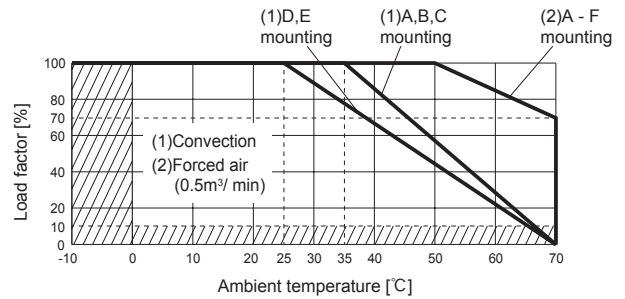

- The operating ambient temperature is different by with / without chassis cover or mounting position.
- In the hatched area, the specification of Ripple, Ripple Noise is different from other area.
- The ambient temperature should be measured 5 to 10 cm away from the power supply so that it won't be influenced by the heat from the power supply.
- Please make sure the maximum component temperature rise given in Instruction manual 3 is not exceeded.
- Please contact us for more information about operating ambient temperature.

Instruction Manuals

- ◆ Please see catalog and instructionmanual before you use.

Instruction Manuals <https://www.cosel.co.jp/redirect/catalog/en/LHA/>
 Before using our product <https://en.cosel.co.jp/technical/caution/index.html>

LHA



NOTICE



Basic Characteristics Data

Model	Circuit method	Switching frequency [kHz] *1 *2	Input current *3 [A]	Inrush current protection	PCB/Pattern			Series/Parallel operation availability	
					Material	Single sided	Double sided	Series operation	Parallel operation
LHA10F	Flyback converter	20 to 125	0.26	Resistance *4	CEM-3	Yes	-	Yes	No
LHA15F	Flyback converter	20 to 125	0.35	Thermistor	CEM-3	Yes	-	Yes	No
LHA30F	Flyback converter	30 to 130	0.62	Thermistor	FR-4	-	Yes	Yes	No
LHA50F	Flyback converter	30 to 130	1.05	Thermistor	FR-4	-	Yes	Yes	No
LHA75F	Active filter	15 to 300	0.9	Thermistor	FR-4	-	Yes	Yes	No
	Flyback converter	50 to 140							
LHA100F	Active filter	15 to 300	1.2	Thermistor	FR-4	-	Yes	Yes	No
	Flyback converter	35 to 130							
LHA150F	Active filter	15 to 300	1.8	Thermistor	FR-4	-	Yes	Yes	No
	LLC resonant converter	90 to 280							
LHA300F	Active filter	15 to 300	3.5	Thermistor	FR-4	-	Yes	Yes	No
	LLC resonant converter	65 to 200							

*1 The value changes depending on input and load.
 *2 At light load, burst operation is performed to reduce input power. The switching frequency is changed by using condition. Please contact us for more details.
 *3 The value of input current is at ACIN 100V and rated load.
 *4 Resistance of the line filter.



LFA-series

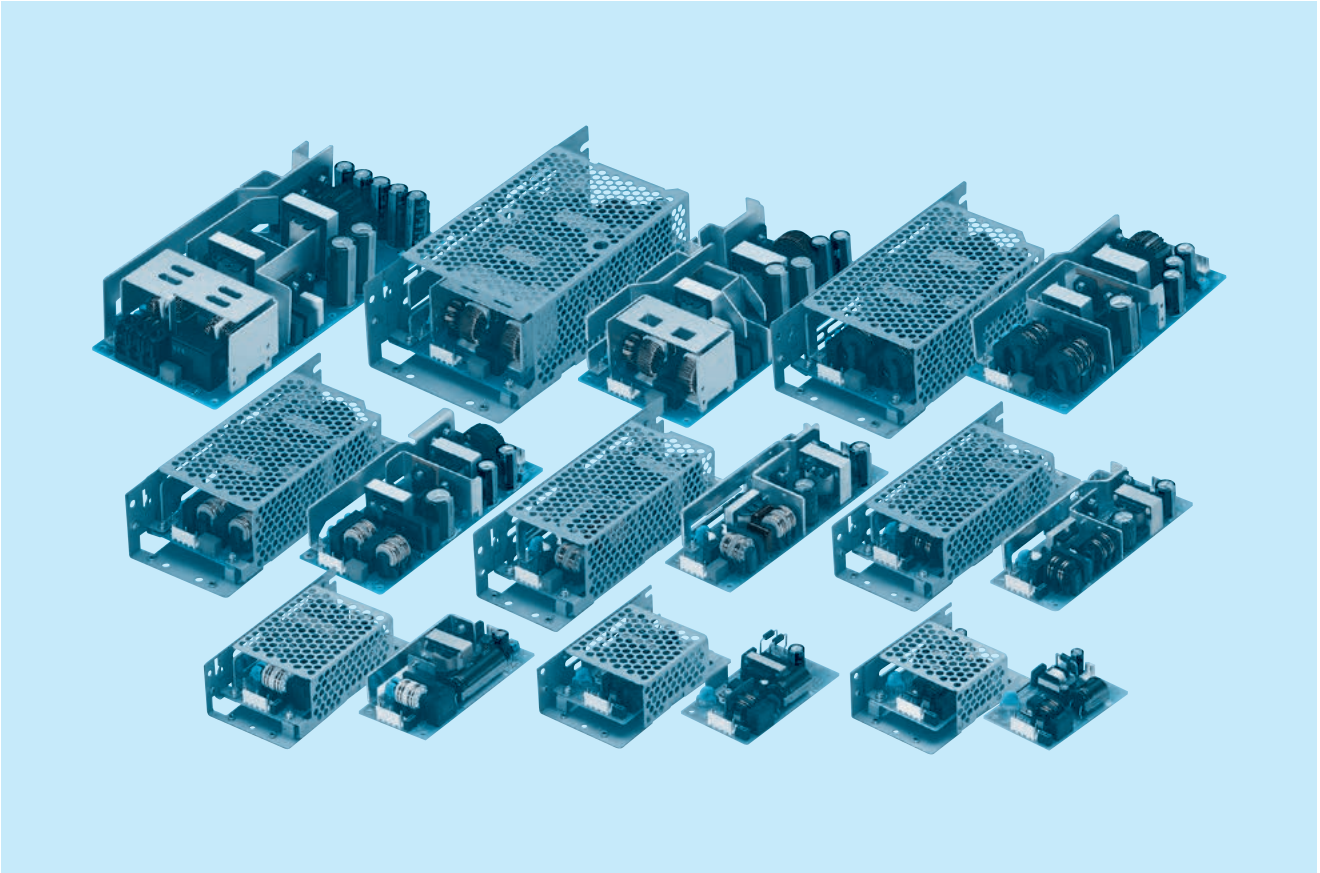

LFA

■ Feature

Small and compact PCB construction
 Built-in inrush current, overcurrent and overvoltage protection circuits
 Harmonic attenuator (Complies with IEC61000-3-2)
 Universal input (AC85-264V)
 Power factor correction (LFA50F-300F)
 Built-in reducing standby power circuit (LFA10F, 15F)

■ Safety agency approvals

UL60950-1, C-UL(CSA60950-1), EN62368-1
 Complies with DEN-AN

■ EMI

Complies with FCC-B, CISPR22-B, EN55011-B, EN55022-B, VCCI-B

■ 5-year warranty (refer to Instruction Manual)

■ CE marking

Low Voltage Directive
 RoHS Directive

■ UKCA marking

Electrical Equipment Safety Regulations
 RoHS Regulations

■ EMS Compliance : EN61204-3, EN61000-6-2

EN61000-4-2
 EN61000-4-3
 EN61000-4-4
 EN61000-4-5
 EN61000-4-6
 EN61000-4-8
 EN61000-4-11

LFA10F

LF A 10 F -□ -□
 ① ② ③ ④ ⑤ ⑥

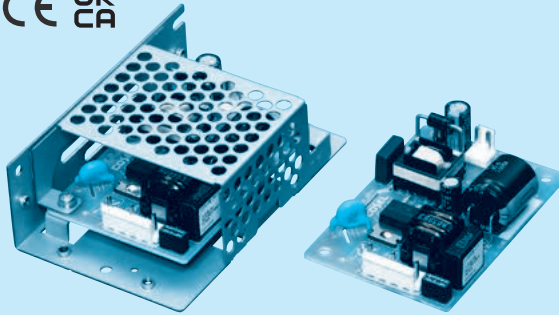
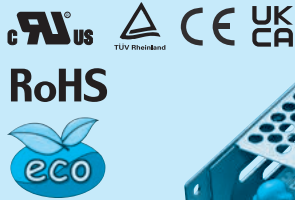

Example recommended EMI/EMC filter
NAC-04-472



High voltage pulse noise type : NAP series
 Low leakage current type : NAM series
 * A higher current rating EMI/EMC filter may be recommended in view of the other devices that could be connected in parallel with the power supply.

- ① Series name
- ② Single output
- ③ Output wattage
- ④ Universal input
- ⑤ Output voltage
- ⑥ Optional
- C : with Coating
- G : Low leakage current
- J1 : VH(J.S.T.)connector type
- S : with Chassis
- SN : with Chassis & cover
- Y : with Potentiometer

Specification is changed at option, refer to Instruction Manual.

This power supply is manufactured by SMD technology. The stress to P.C.B like twisting or bending causes the defect of the unit, so handle the unit with care.
 *Make sure necessary tests will be carried out on your end equipment with the power supply installed in accordance with any required EMC/EMI regulations.

MODEL	LFA10F-3R3-Y	LFA10F-5	LFA10F-12	LFA10F-15	LFA10F-24
MAX OUTPUT WATTAGE[W]	6.6	10	10.8	10.5	12
DC OUTPUT	3.3V 2A	5V 2A	12V 0.9A	15V 0.7A	24V 0.5A

SPECIFICATIONS

	MODEL	LFA10F-3R3-Y	LFA10F-5	LFA10F-12	LFA10F-15	LFA10F-24	
INPUT	VOLTAGE[V]	AC85 - 264 1 φ (Refer to "Derating", Instruction Manual 1 and 3) *3					
	CURRENT[A]	ACIN 100V	0.18typ (Io=100%)	0.26typ (Io=100%)			
		ACIN 200V	0.11typ (Io=100%)	0.16typ (Io=100%)			
	FREQUENCY[Hz]	50 / 60 (47 - 440)					
	EFFICIENCY[%]	ACIN 100V	68.0typ	74.0typ	76.5typ	77.5typ	79.5typ
		ACIN 200V	68.5typ	76.0typ	79.0typ	80.0typ	83.0typ
	INRUSH CURRENT[A]	ACIN 100V	15typ (Io=100%)				
ACIN 200V		30typ (Io=100%)					
LEAKAGE CURRENT[ma]	0.15/0.30max (ACIN 100V / 240V 60Hz, Io=100%, According to IEC62368-1 and DEN-AN)						
OUTPUT	VOLTAGE[V]	3.3	5	12	15	24	
	CURRENT[A]	2.0	2.0	0.9	0.7	0.5	
	LINE REGULATION[mV]	*5 20max	20max	48max	60max	96max	
	LOAD REGULATION[mV]	*5 40max	40max	100max	120max	150max	
	RIPPLE[mVp-p]	*1	0 to +50°C	80max	80max	120max	120max
			-10 - 0°C	140max	140max	160max	160max
			Io=0 - 35%	190max	160max	240max	240max
	RIPPLE NOISE[mVp-p]	*1	0 to +50°C	120max	120max	150max	150max
			-10 - 0°C	160max	160max	180max	180max
			Io=0 - 35%	240max	240max	300max	300max
	TEMPERATURE REGULATION[mV]	0 to +50°C	50max	50max	120max	150max	240max
		-10 to +50°C	60max	60max	150max	180max	290max
	DRIFT[mV]	*2 20max	20max	48max	60max	96max	
START-UP TIME[ms]	200typ (ACIN 100V, Io=100%) * Start-up time is 700ms typ for less than 1 minute of applying input again from turning off the input voltage.						
HOLD-UP TIME[ms]	20typ (ACIN 100V, Io=100%)						
OUTPUT VOLTAGE ADJUSTMENT RANGE[V]	2.85 to 3.63	Fixed ("Y"option is available for adjusting output voltage between ±10%)					
OUTPUT VOLTAGE SETTING[V]	3.30 to 3.40	4.90 to 5.30	11.50 to 12.50	14.40 to 15.60	23.00 to 25.00		
PROTECTION CIRCUIT AND OTHERS	OVERCURRENT PROTECTION	Works over 105% of rating and recovers automatically					
	OVERVOLTAGE PROTECTION	4.00 to 5.25	5.75 to 7.00	13.80 to 16.80	17.25 to 21.00	27.60 to 33.60	
	OPERATING INDICATION	Not provided					
	REMOTE SENSING	Not provided					
ISOLATION	REMOTE ON/OFF	Not provided					
	INPUT-OUTPUT	AC3,000V 1minute, Cutoff current = 10mA, DC500V 50MΩ min (At Room Temperature)					
	INPUT-FG	AC2,000V 1minute, Cutoff current = 10mA, DC500V 50MΩ min (At Room Temperature)					
	OUTPUT-FG	AC500V 1minute, Cutoff current = 25mA, DC500V 50MΩ min (At Room Temperature)					
ENVIRONMENT	OPERATING TEMP., HUMID. AND ALTITUDE	-10 to +70°C, 20 - 90%RH (Non condensing) (Refer to "Derating", Instruction Manual 3), 3,000m (10,000 feet) max *3					
	STORAGE TEMP., HUMID. AND ALTITUDE	-20 to +75°C, 20 - 90%RH (Non condensing), 9,000m (30,000 feet) max					
	VIBRATION	10 - 55Hz, 19.6m/s ² (2G), 3minutes period, 60minutes each along X, Y and Z axis					
	IMPACT	196.1m/s ² (20G), 11ms, once each X, Y and Z axis					
SAFETY AND NOISE REGULATIONS	AGENCY APPROVALS	UL60950-1, C-UL (CSA60950-1), EN62368-1 Complies with DEN-AN					
	CONDUCTED NOISE	Complies with FCC-B, VCCI-B, CISPR-B, EN55011-B, EN55022-B					
	HARMONIC ATTENUATOR	Complies with IEC61000-3-2 (Class A) *6 (Not built-in to active filter) *4					
OTHERS	CASE SIZE/WEIGHT	50 X 22 X 73.5mm [1.97 X 0.87 X 2.89 inches] (W X H X D) / 55g max (with chassis & cover : 150g max)					
	COOLING METHOD	Convection (Refer to "Derating", Instruction Manual 3) *3					

*1 This is the value that measured on measuring board with capacitor of 22 μF at 150mm from output terminal. Measured by 20MHz oscilloscope or Ripple-Noise meter (Equivalent to KEISOKU-GIKEN: FM103). A circuit reducing standby power is built in this unit. Therefore, the internal switch element is intermittent operated, and the Ripple/Ripple Noise specification in load

factor Io=0-35% is different. Please refer to the Instruction Manual 1.7.
 *2 Drift is the change in DC output for an eight hour period after a half-hour warm-up at 25°C, with the input voltage held constant at the rated input/output. Derating is required.
 *3 When two or more units are operating it may not comply with the IEC61000-3-2.

Please contact us for details.
 *5 Please contact us about dynamic load and input response.
 *6 Please contact us about another class.
 * To meet the specifications. Do not operate over-loaded condition. Parallel operation is not possible.
 * Derating is required when operated with chassis and cover.
 * Sound noise may be generated by power supply in case of pulse load.

Block diagram

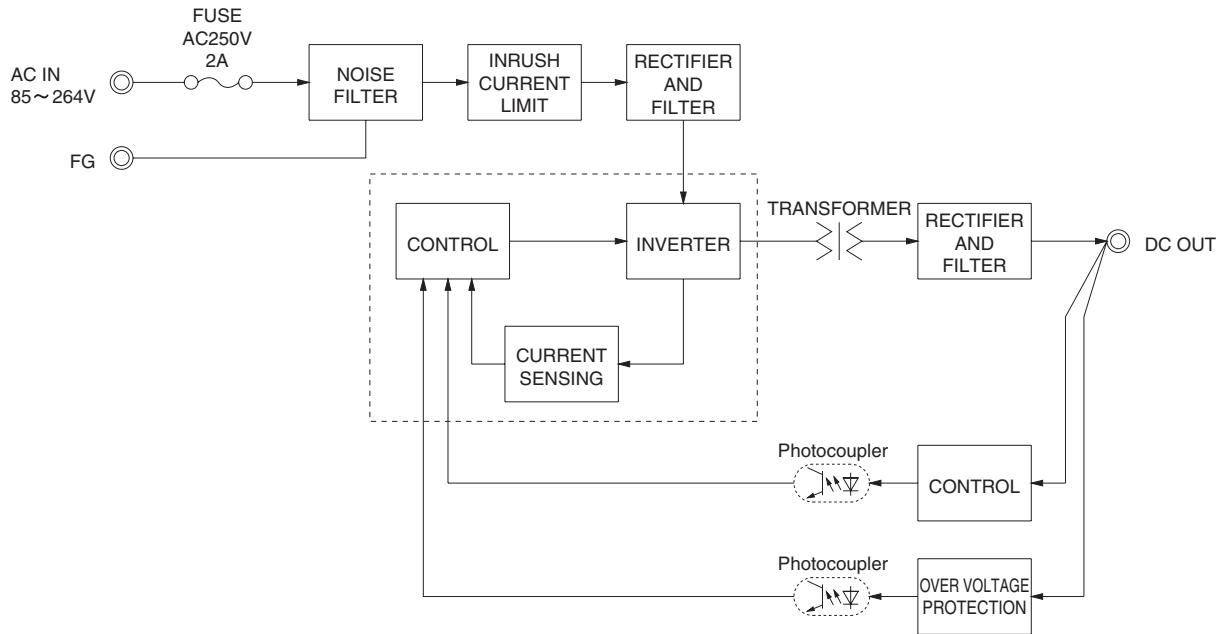

External view

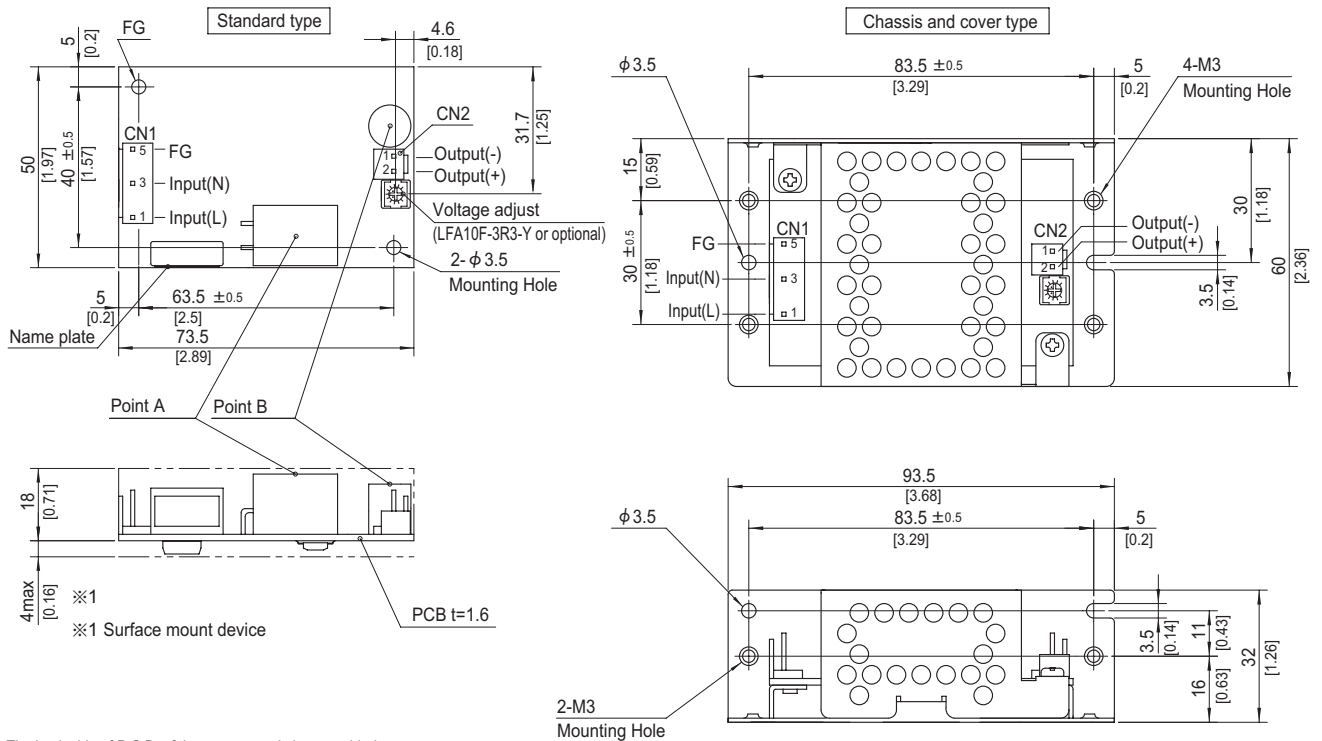

※ The back side of P.C.B. of the power supply is assembled some SMDs.

Be attention not to bump against the attached area by vibration.

※ Use the spacer of 8mm length or more regarding insulation.

And do not use press-fitting bush.

※ Point A, Point B are thermometry points. Please refer to Instruction Manual 3.

I/O Connector	Mating connector	Terminal
CN1	1-1123724-3	Chain 1123721-1 Loose 1318912-1
CN2	1-1123723-2	Chain 1123721-1 Loose 1318912-1

(Mfr:Tyco Electronics)

※ I/O Connector is Mfr. Tyco Electronics

※ Option:-J1:(J.S.T) connector type. Refer to Instruction Manual 6.

<PIN CONNECTION>

CN1

Pin No.	Input
1	AC(L)
2	
3	AC(N)
4	
5	FG

CN2

Pin No.	Output
1	-V
2	+V

※ Tolerance : ± 1 [± 0.04]

※ Weight : 55g max (with chassis & cover : 150g max)

※ PCB material / thickness : CEM3 / 1.6mm

※ Optional chassis and cover material : Electric galvanizing steel board.

※ Dimensions in mm, []=inches

※ Mounting torque (Mounting hole of chassis) : $0.6N \cdot m$ (6.3kgf · cm) max

LFA15F

① LF ② A ③ 15 ④ F ⑤ -□ ⑥ -□

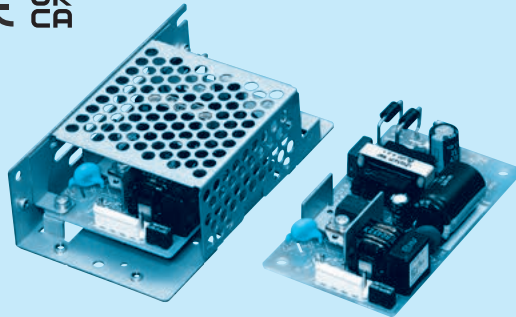

Example recommended EMI/EMC filter
NAC-04-472



High voltage pulse noise type : NAP series
Low leakage current type : NAM series
* A higher current rating EMI/EMC filter may be recommended in view of the other devices that could be connected in parallel with the power supply.

- ① Series name
- ② Single output
- ③ Output wattage
- ④ Universal input
- ⑤ Output voltage
- ⑥ Optional
- C : with Coating
- G : Low leakage current
- J1 : VH(J.S.T.)connector type
- S : with Chassis
- SN : with Chassis & cover
- Y : with Potentiometer

Specification is changed at option, refer to Instruction Manual.

This power supply is manufactured by SMD technology. The stress to P.C.B like twisting or bending causes the defect of the unit, so handle the unit with care.
*Make sure necessary tests will be carried out on your end equipment with the power supply installed in accordance with any required EMC/EMI regulations.

MODEL	LFA15F-3R3-Y	LFA15F-5	LFA15F-12	LFA15F-15	LFA15F-24
MAX OUTPUT WATTAGE[W]	9.9	15	15.6	15	16.8
DC OUTPUT	3.3V 3A	5V 3A	12V 1.3A	15V 1A	24V 0.7A

SPECIFICATIONS

	MODEL	LFA15F-3R3-Y	LFA15F-5	LFA15F-12	LFA15F-15	LFA15F-24	
INPUT	VOLTAGE[V]	AC85 - 264 1 φ (Refer to "Derating", Instruction Manual 1 and 3) *3					
	CURRENT[A]	ACIN 100V	0.24typ (Io=100%)	0.35typ (Io=100%)			
		ACIN 200V	0.15typ (Io=100%)	0.20typ (Io=100%)			
	FREQUENCY[Hz]	50 / 60 (47 - 440)					
	EFFICIENCY[%]	ACIN 100V	68.0typ	73.0typ	76.0typ	77.0typ	78.0typ
		ACIN 200V	69.0typ	76.0typ	78.5typ	80.0typ	81.5typ
	INRUSH CURRENT[A]	ACIN 100V	15typ (Io=100%) (At cold start) (Ta=25°C)				
ACIN 200V		30typ (Io=100%) (At cold start) (Ta=25°C)					
LEAKAGE CURRENT[ma]	0.15/0.30max (ACIN 100V / 240V 60Hz, Io=100%, According to IEC62368-1 and DEN-AN)						
OUTPUT	VOLTAGE[V]	3.3	5	12	15	24	
	CURRENT[A]	3.0	3.0	1.3	1.0	0.7	
	LINE REGULATION[mV]	*5 20max	20max	48max	60max	96max	
	LOAD REGULATION[mV]	*5 40max	40max	100max	120max	150max	
	RIPPLE[mVp-p]	*1	0 to +50°C	80max	80max	120max	120max
			-10 - 0°C	140max	140max	160max	160max
			Io=0 - 35%	190max	160max	240max	240max
	RIPPLE NOISE[mVp-p]	*1	0 to +50°C	120max	120max	150max	150max
			-10 - 0°C	160max	160max	180max	180max
			Io=0 - 35%	240max	240max	300max	300max
	TEMPERATURE REGULATION[mV]	0 to +50°C	50max	50max	120max	150max	240max
		-10 to +50°C	60max	60max	150max	180max	290max
	DRIFT[mV]	*2 20max	20max	48max	60max	96max	
START-UP TIME[ms]	200typ (ACIN 100V, Io=100%) * Start-up time is 700ms typ for less than 1 minute of applying input again from turning off the input voltage.						
HOLD-UP TIME[ms]	20typ (ACIN 100V, Io=100%)						
OUTPUT VOLTAGE ADJUSTMENT RANGE[V]	2.85 to 3.63	Fixed ("Y"option is available for adjusting output voltage between ±10%)					
OUTPUT VOLTAGE SETTING[V]	3.30 to 3.40	4.90 to 5.30	11.50 to 12.50	14.40 to 15.60	23.00 to 25.00		
PROTECTION CIRCUIT AND OTHERS	OVERCURRENT PROTECTION	Works over 105% of rating and recovers automatically					
	OVERVOLTAGE PROTECTION	4.00 to 5.25	5.75 to 7.00	13.80 to 16.80	17.25 to 21.00	27.60 to 33.60	
	OPERATING INDICATION	Not provided					
	REMOTE SENSING	Not provided					
ISOLATION	REMOTE ON/OFF	Not provided					
	INPUT-OUTPUT	AC3,000V 1minute, Cutoff current = 10mA, DC500V 50MΩ min (At Room Temperature)					
	INPUT-FG	AC2,000V 1minute, Cutoff current = 10mA, DC500V 50MΩ min (At Room Temperature)					
	OUTPUT-FG	AC500V 1minute, Cutoff current = 25mA, DC500V 50MΩ min (At Room Temperature)					
ENVIRONMENT	OPERATING TEMP., HUMID. AND ALTITUDE	-10 to +70°C, 20 - 90%RH (Non condensing) (Refer to "Derating", Instruction Manual 3), 3,000m (10,000 feet) max *3					
	STORAGE TEMP., HUMID. AND ALTITUDE	-20 to +75°C, 20 - 90%RH (Non condensing), 9,000m (30,000 feet) max					
	VIBRATION	10 - 55Hz, 19.6m/s ² (2G), 3minutes period, 60minutes each along X, Y and Z axis					
	IMPACT	196.1m/s ² (20G), 11ms, once each X, Y and Z axis					
SAFETY AND NOISE REGULATIONS	AGENCY APPROVALS	UL60950-1, C-UL (CSA60950-1), EN62368-1 Complies with DEN-AN					
	CONDUCTED NOISE	Complies with FCC-B, VCCI-B, CISPR-B, EN55011-B, EN55022-B					
	HARMONIC ATTENUATOR	Complies with IEC61000-3-2 (Class A) *6 (Not built-in to active filter) *4					
OTHERS	CASE SIZE/WEIGHT	50 X 22 X 87.5mm [1.97 X 0.87 X 3.44 inches] (W X H X D) / 80g max (with chassis & cover : 190g max)					
	COOLING METHOD	Convection (Refer to "Derating", Instruction Manual 3) *3					

*1 This is the value that measured on measuring board with capacitor of 22 μF at 150mm from output terminal.
Measured by 20MHz oscilloscope or Ripple-Noise meter (Equivalent to KEISOKU-GIKEN: RM103).
A circuit reducing standby power is built in this unit.
Therefore, the internal switch element is intermittent operated, and the Ripple/Ripple Noise specification in load

factor Io=0-35% is different.
Please refer to the Instruction Manual 1.7.
*2 Drift is the change in DC output for an eight hour period after a half-hour warm-up at 25°C, with the input voltage held constant at the rated input/output.
Derating is required.
*3 When two or more units are operating it may not comply with the IEC61000-3-2.

Please contact us for details.
*5 Please contact us about dynamic load and input response.
*6 Please contact us about another class.
* To meet the specifications. Do not operate over-loaded condition.
Parallel operation is not possible.
Derating is required when operated with chassis and cover.
Sound noise may be generated by power supply in case of pulse load.

Block diagram

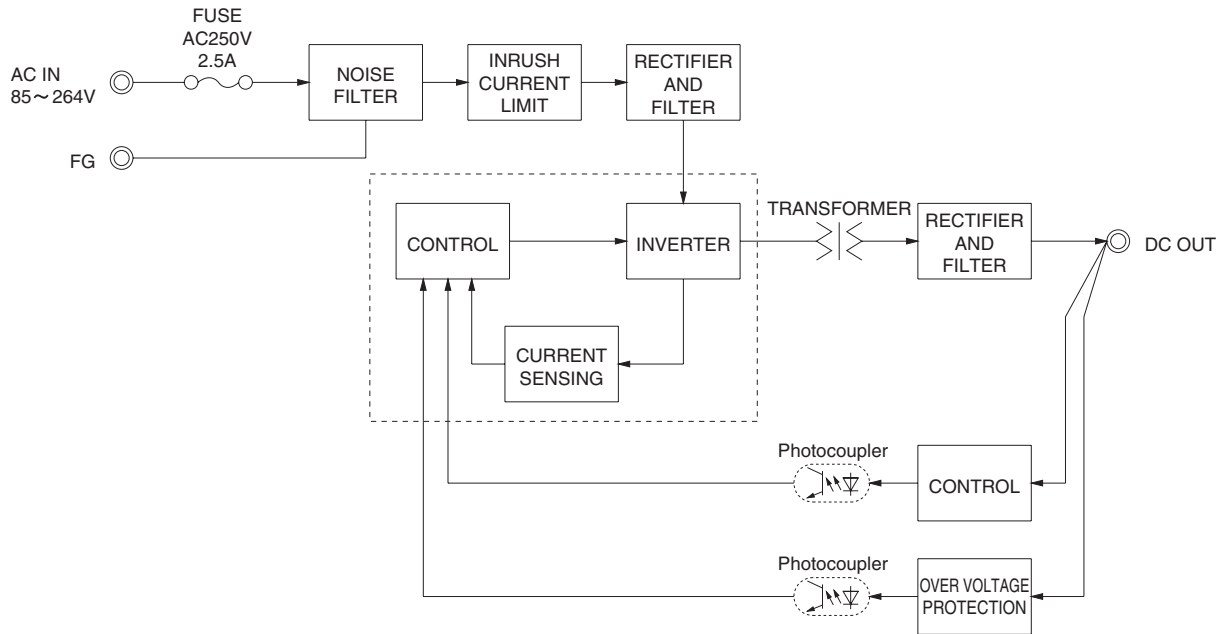

External view

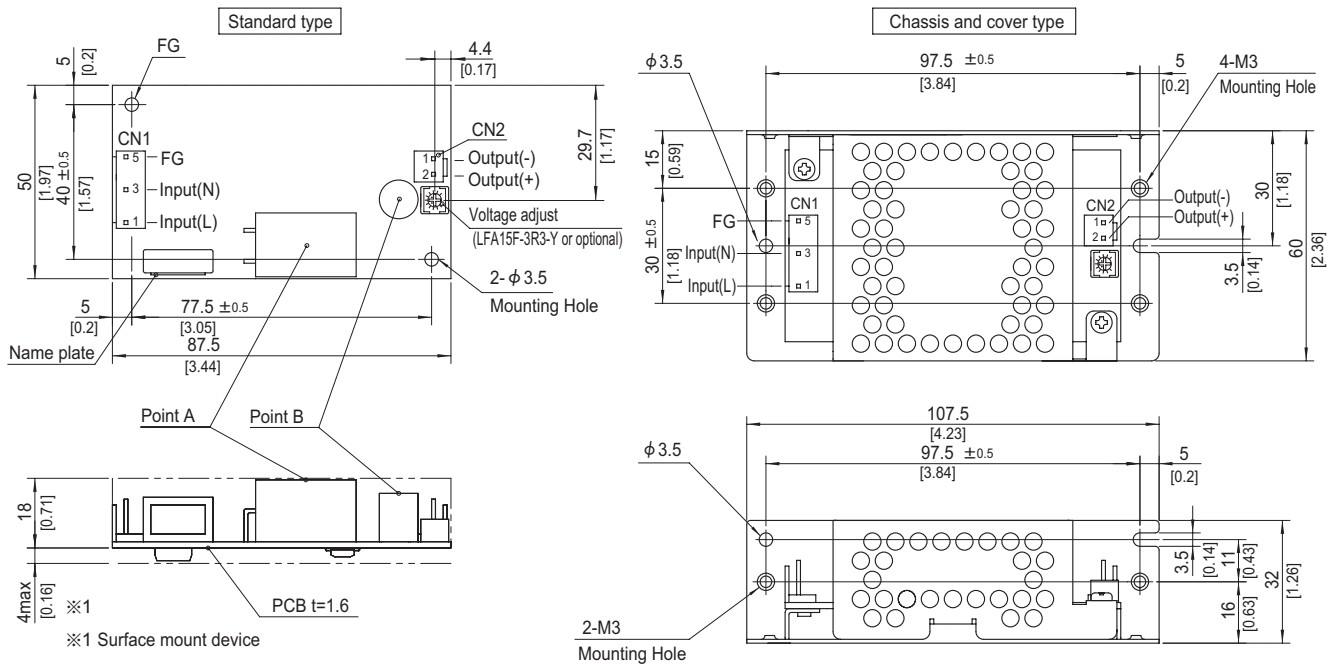

- ※ The back side of P.C.B. of the power supply is assembled some SMDs.
Be attention not to bump against the attached area by vibration.
- ※ Use the spacer of 8mm length or more regarding insulation.
And do not use press-fitting bush.
- ※ Point A, Point B are thermometry points. Please refer to Instruction Manual 3.

I/O Connector	Mating connector	Terminal	Terminal
CN1	1-1123722-5	Chain	1123721-1
		Loose	1318912-1
		Chain	1123721-1
CN2	1-1123722-2	Chain	1123721-1
		Loose	1318912-1

(Mfr:Tyco Electronics)

- ※ I/O Connector is Mfr. Tyco Electronics
- ※ Option-J1:(J.S.T) connector type. Refer to Instruction Manual 6.

<PIN CONNECTION>

CN1

Pin No.	Input
1	AC(L)
2	
3	AC(N)
4	
5	FG

CN2

Pin No.	Output
1	-V
2	+V

- ※ Tolerance : ± 1 [± 0.04]
- ※ Weight : 80g max (with chassis & cover : 190g max)
- ※ PCB material / thickness : CEM3 / 1.6mm
- ※ Optional chassis and cover material : Electric galvanizing steel board.
- ※ Dimensions in mm, []=inches
- ※ Mounting torque (Mounting hole of chassis) : $0.6N \cdot m$ (6.3kgf · cm) max

LFA30F

LF A 30 F -□ -□
 ① ② ③ ④ ⑤ ⑥

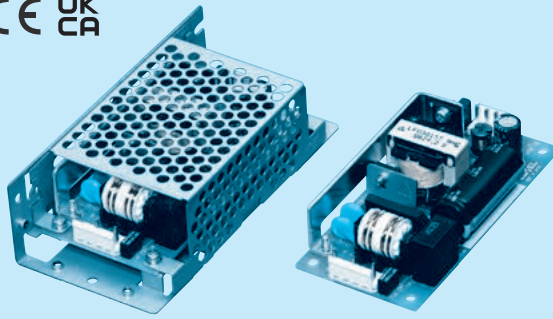

Example recommended EMI/EMC filter
NAC-04-472



High voltage pulse noise type : NAP series
 Low leakage current type : NAM series
 * A higher current rating EMI/EMC filter may be recommended in view of the other devices that could be connected in parallel with the power supply.

- ① Series name
- ② Single output
- ③ Output wattage
- ④ Universal input
- ⑤ Output voltage
- ⑥ Optional
- C : with Coating
- G : Low leakage current
- J1 : VH(J.S.T.)connector type
- S : with Chassis
- SN : with Chassis & cover
- Y : with Potentiometer

Specification is changed at option, refer to Instruction Manual.

This power supply is manufactured by SMD technology. The stress to P.C.B like twisting or bending causes the defect of the unit, so handle the unit with care.
 *Make sure necessary tests will be carried out on your end equipment with the power supply installed in accordance with any required EMC/EMI regulations.

MODEL	LFA30F-3R3-Y	LFA30F-5	LFA30F-12	LFA30F-15	LFA30F-24
MAX OUTPUT WATTAGE[W]	19.8	30.0	30.0	30.0	31.2
DC OUTPUT	3.3V 6A	5V 6A	12V 2.5A	15V 2A	24V 1.3A

SPECIFICATIONS

	MODEL	LFA30F-3R3-Y	LFA30F-5	LFA30F-12	LFA30F-15	LFA30F-24	
INPUT	VOLTAGE[V]	AC85 - 264 1 φ (Refer to "Derating", Instruction Manual 1 and 3) *3					
	CURRENT[A]	ACIN 100V	0.50typ (Io=100%)	0.65typ (Io=100%)			
		ACIN 200V	0.30typ (Io=100%)	0.35typ (Io=100%)			
	FREQUENCY[Hz]	50 / 60 (47 - 440)					
	EFFICIENCY[%]	ACIN 100V	73typ	76typ	79typ	81typ	82typ
		ACIN 200V	75typ	79typ	81typ	83typ	84typ
INRUSH CURRENT[A]	ACIN 100V	15typ (Io=100%) (At cold start) (Ta=25°C)					
	ACIN 200V	30typ (Io=100%) (At cold start) (Ta=25°C)					
LEAKAGE CURRENT[mA]	0.30 / 0.65max (ACIN 100V / 240V 60Hz, Io=100%, According to IEC62368-1 and DEN-AN)						
OUTPUT	VOLTAGE[V]	3.3	5	12	15	24	
	CURRENT[A]	6.0	6.0	2.5	2.0	1.3	
	LINE REGULATION[mV] *5	20max	20max	48max	60max	96max	
	LOAD REGULATION[mV] *5	40max	40max	100max	120max	150max	
	RIPPLE[mVp-p]	0 to +50°C *1	80max	80max	120max	120max	120max
		-10 to 0°C *1	140max	140max	160max	160max	160max
	RIPPLE NOISE[mVp-p]	0 to +50°C *1	120max	120max	150max	150max	150max
		-10 to 0°C *1	160max	160max	180max	180max	180max
	TEMPERATURE REGULATION[mV]	0 to +50°C	50max	50max	120max	150max	240max
		-10 to +50°C	60max	60max	150max	180max	290max
	DRIFT[mV] *2	20max	20max	48max	60max	96max	
START-UP TIME[ms]	150typ (ACIN 100V, Io=100%)						
HOLD-UP TIME[ms]	20typ (ACIN 100V, Io=100%)						
OUTPUT VOLTAGE ADJUSTMENT RANGE[V]	2.85 to 3.63	Fixed ("Y"option is available for adjusting output voltage between ±10%)					
OUTPUT VOLTAGE SETTING[V]	3.30 to 3.40	4.90 to 5.30	11.50 to 12.50	14.40 to 15.60	23.00 to 25.00		
PROTECTION CIRCUIT AND OTHERS	OVERCURRENT PROTECTION	Works over 105% of rating and recovers automatically					
	OVERVOLTAGE PROTECTION	4.00 to 5.25	5.75 to 7.00	13.80 to 16.80	17.25 to 21.00	27.60 to 33.60	
	OPERATING INDICATION	Not provided					
	REMOTE SENSING	Not provided					
ISOLATION	REMOTE ON/OFF	Not provided					
	INPUT-OUTPUT	AC3,000V 1minute, Cutoff current = 10mA, DC500V 50MΩ min (At Room Temperature)					
	INPUT-FG	AC2,000V 1minute, Cutoff current = 10mA, DC500V 50MΩ min (At Room Temperature)					
ENVIRONMENT	OUTPUT-FG	AC500V 1minute, Cutoff current = 25mA, DC500V 50MΩ min (At Room Temperature)					
	OPERATING TEMP., HUMID. AND ALTITUDE	-10 to +70°C, 20 - 90%RH (Non condensing) (Refer to "Derating", Instruction Manual 3), 3,000m (10,000feet) max *3					
	STORAGE TEMP., HUMID. AND ALTITUDE	-20 to +75°C, 20 - 90%RH (Non condensing), 9,000m (30,000feet) max					
SAFETY AND NOISE REGULATIONS	VIBRATION	10 - 55Hz, 19.6m/s ² (2G), 3minutes period, 60minutes each along X, Y and Z axis					
	IMPACT	196.1m/s ² (20G), 11ms, once each X, Y and Z axis					
OTHERS	AGENCY APPROVALS	UL60950-1, C-UL (CSA60950-1), EN62368-1 Complies with DEN-AN					
	CONDUCTED NOISE	Complies with FCC-B, VCCI-B, CISPR-B, EN55011-B, EN55022-B					
	HARMONIC ATTENUATOR	Complies with IEC61000-3-2 (Class A) *6 (Not built-in to active filter) *4					
OTHERS	CASE SIZE/WEIGHT	50 × 26.5 × 105mm [1.97 × 1.04 × 4.13 inches] (W × H × D) / 130g max (with chassis & cover : 260g max)					
	COOLING METHOD	Convection (Refer to "Derating", Instruction Manual 3) *3					

*1 This is the value that measured on measuring board with capacitor of 22 μF at 150mm from output terminal.
 Measured by 20MHz oscilloscope or Ripple-Noise meter (Equivalent to KEISOKU-GIKEN: RM103).
 *2 Drift is the change in DC output for an eight hour period after a half-hour warm-up at 25°C, with the input voltage held constant at the rated input/output.
 *3 Derating is required.

*4 When two or more units are operating it may not comply with the IEC61000-3-2. Please contact us for details.
 *5 Please contact us about dynamic load and input response.
 *6 Please contact us about another class.
 * To meet the specifications. Do not operate over-loaded condition.
 * Parallel operation is not possible.
 * Derating is required when operated with chassis and cover.
 * Sound noise may be generated by power supply in case of pulse load.

Block diagram

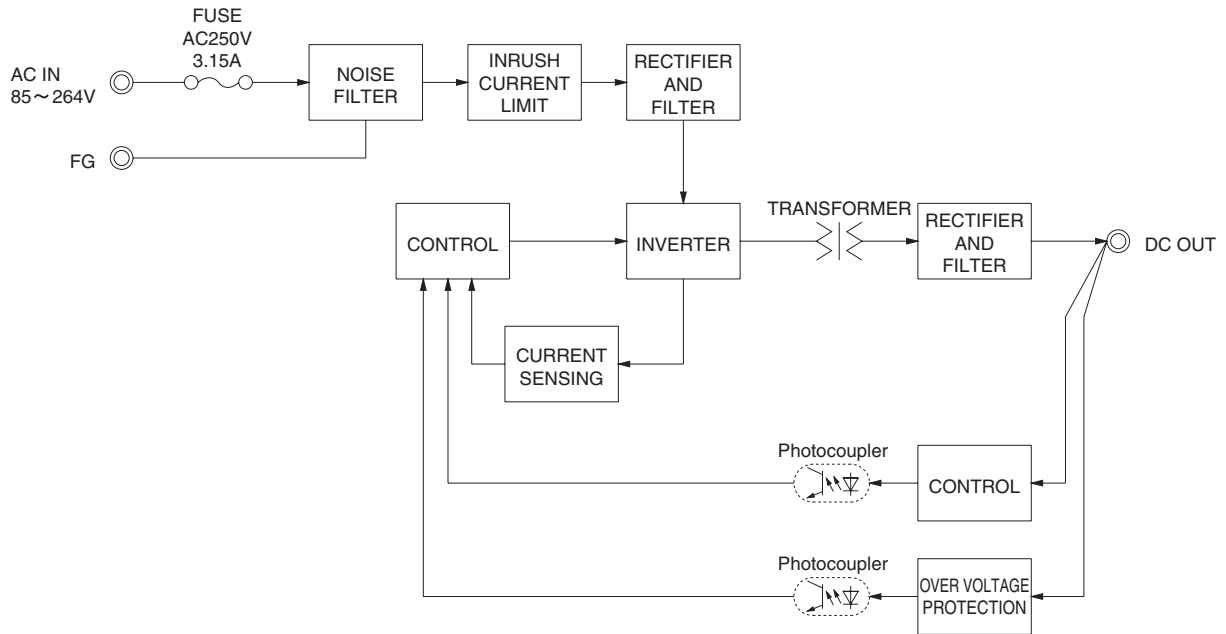

External view

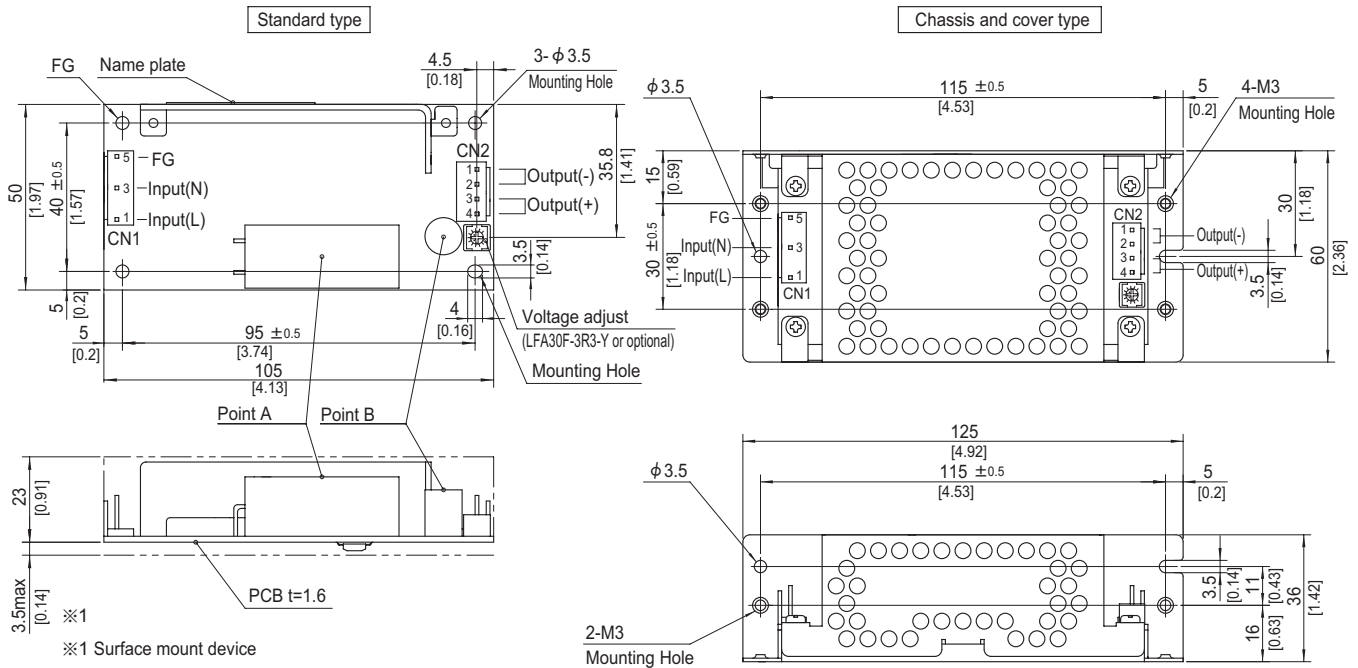

- ※ 4 Mounting holes are existing.
- ※ The back side of P.C.B. of the power supply is assembled some SMDs.
- Be attention not to bump against the attached area by vibration.
- ※ Use the spacer of 8mm length or more regarding insulation.
- And do not use press-fitting bush.
- ※ Point A, Point B are thermometry points. Please refer to Instruction Manual 3.

I/O Connector	Mating connector	Terminal
CN1	1-1123724-3	Chain 1123721-1
		Loose 1318912-1
CN2	1-1123723-4	Chain 1123721-1
		Loose 1318912-1

(Mfr:Tyco Electronics)

- ※ I/O Connector is Mfr. Tyco Electronics
- ※ Option:-J1:(J.S.T) connector type. Refer to Instruction Manual 6.

<PIN CONNECTION>

CN1		CN2	
Pin No.	Input	Pin No.	Output
1	AC(L)	1, 2	-V
2			
3	AC(N)	3, 4	+V
4			
5	FG		

- ※ Tolerance : ± 1 [±0.04]
- ※ Weight: 130g max (with chassis & cover : 260g max)
- ※ PCB material / thickness : CEM3 / 1.6mm
- ※ Optional chassis and cover material : Electric galvanizing steel board.
- ※ Dimensions in mm, []=inches
- ※ Mounting torque (Mounting hole of chassis) : 0.6N · m (6.3kgf · cm) max

※ Keep drawing current per pin below 5A for CN2.

LFA50F

LF A 50 F -□ -□
 ① ② ③ ④ ⑤ ⑥

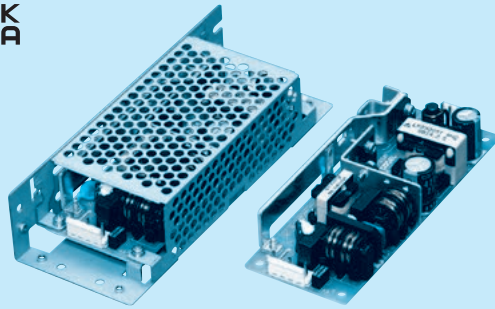
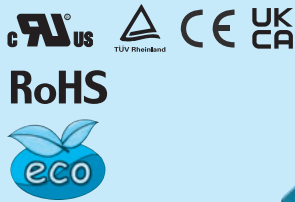

Example recommended EMI/EMC filter
NAC-04-472



High voltage pulse noise type : NAP series
 Low leakage current type : NAM series
 * A higher current rating EMI/EMC filter may be recommended in view of the other devices that could be connected in parallel with the power supply.

- ① Series name
- ② Single output
- ③ Output wattage
- ④ Universal input
- ⑤ Output voltage
- ⑥ Optional
- C : with Coating
- G : Low leakage current
- J1 : VH(J.S.T.)connector type
- S : with Chassis
- SN : with Chassis & cover
- Y : with Potentiometer

Specification is changed at option, refer to Instruction Manual.

This power supply is manufactured by SMD technology. The stress to P.C.B like twisting or bending causes the defect of the unit, so handle the unit with care.
 *Make sure necessary tests will be carried out on your end equipment with the power supply installed in accordance with any required EMC/EMI regulations.

MODEL	LFA50F-3R3-Y	LFA50F-5	LFA50F-12	LFA50F-15	LFA50F-24	LFA50F-36	LFA50F-48
MAX OUTPUT WATTAGE[W]	33	50	51.6	52.5	50.4	50.4	52.8
DC OUTPUT	3.3V 10A	5V 10A	12V 4.3A	15V 3.5A	24V 2.1A	36V 1.4A	48V 1.1A

SPECIFICATIONS

	MODEL	LFA50F-3R3-Y	LFA50F-5	LFA50F-12	LFA50F-15	LFA50F-24	LFA50F-36	LFA50F-48	
INPUT	VOLTAGE[V]	AC85 - 264 1 φ (Refer to "Derating", Instruction Manual 1 and 3) *3							
	CURRENT[A]	ACIN 100V	0.47typ (Io=100%)	0.67typ (Io=100%)					
		ACIN 200V	0.27typ (Io=100%)	0.36typ (Io=100%)					
	FREQUENCY[Hz]	50 / 60 (47 - 63)							
	EFFICIENCY[%]	ACIN 100V	73.5typ	77.5typ	80.0typ	80.5typ	81.5typ	82.0typ	81.0typ
		ACIN 200V	74.0typ	79.0typ	81.5typ	81.5typ	83.0typ	83.5typ	82.5typ
	POWER FACTOR (Io=100%)	ACIN 100V	0.96typ	0.97typ					
		ACIN 200V	0.83typ	0.90typ					
INRUSH CURRENT[A]	ACIN 100V	15typ (Io=100%) (At cold start) (Ta=25°C)							
	ACIN 200V	30typ (Io=100%) (At cold start) (Ta=25°C)							
LEAKAGE CURRENT[mA]	0.40 / 0.75max (ACIN 100V / 240V 60Hz, Io=100%, According to IEC62368-1 and DEN-AN)								
OUTPUT	VOLTAGE[V]	3.3	5	12	15	24	36	48	
	CURRENT[A]	10.0	10.0	4.3	3.5	2.1	1.4	1.1	
	LINE REGULATION[mV]	*4	20max	20max	48max	60max	96max	144max	192max
	LOAD REGULATION[mV]	*4	40max	40max	100max	120max	150max	240max	240max
	RIPPLE[mVp-p]	0 to +50°C *1	80max	80max	120max	120max	150max	150max	150max
		-10 - 0°C *1	140max	140max	160max	160max	160max	200max	200max
	RIPPLE NOISE[mVp-p]	0 to +50°C *1	120max	120max	150max	150max	150max	250max	250max
		-10 - 0°C *1	160max	160max	180max	180max	180max	300max	300max
	TEMPERATURE REGULATION[mV]	0 to +50°C	50max	50max	120max	150max	240max	360max	480max
		-10 to +50°C	60max	60max	150max	180max	290max	450max	600max
	DRIFT[mV]	*2	20max	20max	48max	60max	96max	144max	192max
	START-UP TIME[ms]	350typ (ACIN 100V, Io=100%)							
	HOLD-UP TIME[ms]	20typ (ACIN 100V, Io=100%)							
OUTPUT VOLTAGE ADJUSTMENT RANGE[V]	2.85 to 3.63		Fixed ("Y"option is available for adjusting output voltage between ±10%)						
OUTPUT VOLTAGE SETTING[V]	3.30 to 3.40		4.90 to 5.30		11.50 to 12.50		17.25 to 21.00		
PROTECTION CIRCUIT AND OTHERS	OVERCURRENT PROTECTION	Works over 105% of rating and recovers automatically							
	OVERVOLTAGE PROTECTION	4.00 to 5.25	5.75 to 7.00	13.80 to 16.80	17.25 to 21.00	27.60 to 33.60	41.40 to 50.40	55.20 to 67.20	
	OPERATING INDICATION	Not provided							
	REMOTE SENSING	Not provided							
	REMOTE ON/OFF	Not provided							
ISOLATION	INPUT-OUTPUT	AC3,000V 1minute, Cutoff current = 10mA, DC500V 50MΩ min (At Room Temperature)							
	INPUT-FG	AC2,000V 1minute, Cutoff current = 10mA, DC500V 50MΩ min (At Room Temperature)							
	OUTPUT-FG	AC500V 1minute, Cutoff current = 25mA, DC500V 50MΩ min (At Room Temperature)							
ENVIRONMENT	OPERATING TEMP., HUMID. AND ALTITUDE	-10 to +70°C, 20 - 90%RH (Non condensing) (Refer to "Derating", Instruction Manual 3), 3,000m (10,000feet) max *3							
	STORAGE TEMP., HUMID. AND ALTITUDE	-20 to +75°C, 20 - 90%RH (Non condensing), 9,000m (30,000feet) max							
	VIBRATION	10 - 55Hz, 19.6m/s ² (2G), 3minutes period, 60minutes each along X, Y and Z axis							
	IMPACT	196.1m/s ² (20G), 11ms, once each X, Y and Z axis							
SAFETY AND NOISE REGULATIONS	AGENCY APPROVALS	UL60950-1, C-UL (CSA60950-1), EN62368-1 Complies with DEN-AN							
	CONDUCTED NOISE	Complies with FCC-B, VCCI-B, CISPR-B, EN55011-B, EN55022-B							
	HARMONIC ATTENUATOR	Complies with IEC61000-3-2 (Class A) *5							
OTHERS	CASE SIZE/WEIGHT	50 X 26.5 X 132mm [1.97 X 1.04 X 5.20 inches] (W X H X D) / 165g max (with chassis & cover : 325g max)							
	COOLING METHOD	Convection (Refer to "Derating", Instruction Manual 3) *3							

*1 This is the value that measured on measuring board with capacitor of 22 μF at 150mm from output terminal.
 Measured by 20MHz oscilloscope or Ripple-Noise meter (Equivalent to KEISOKU-GIKEN: RM103).

*2 Drift is the change in DC output for an eight hour period after a half-hour warm-up at 25°C, with the input voltage held constant at the rated input/output.

*3 Derating is required.

*4 Please contact us about dynamic load and input response.

*5 Please contact us about another class.

* To meet the specifications. Do not operate over-loaded condition.

* Parallel operation is not possible.

* Derating is required when operated with chassis and cover.

* Sound noise may be generated by power supply in case of pulse load.

Block diagram

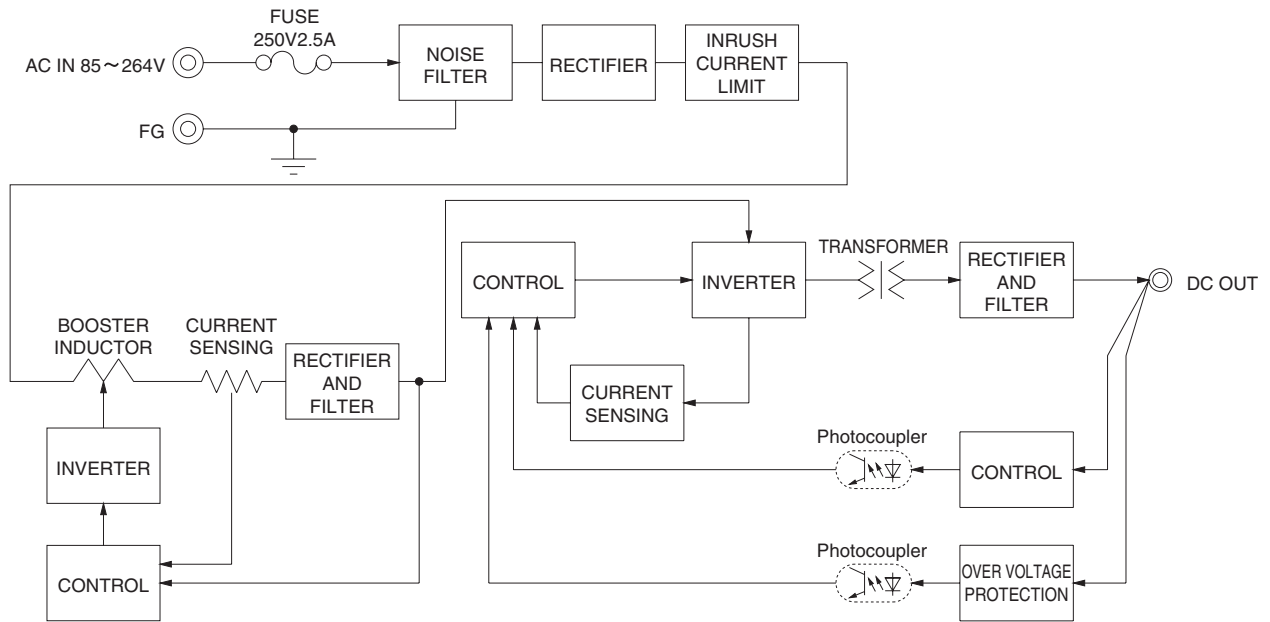

External view

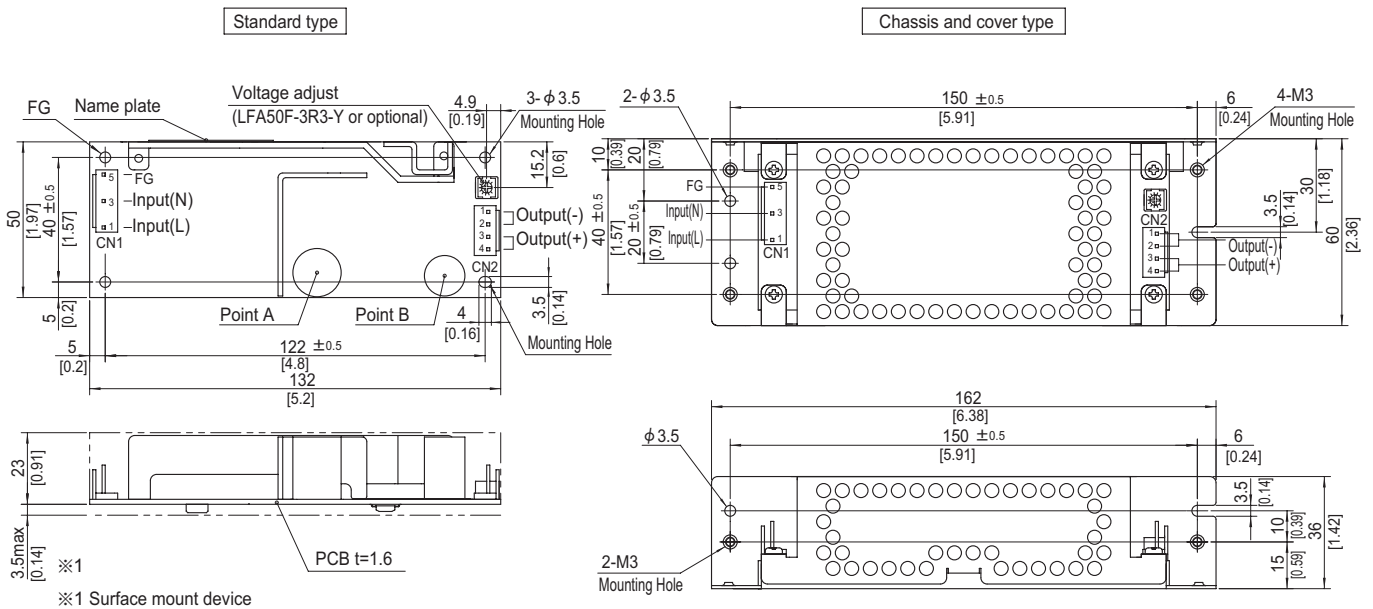

- ※ 4 Mounting holes are existing.
- ※ The back side of P.C.B. of the power supply is assembled some SMDs.
Be attention not to bump against the attached area by vibration.
- ※ Use the spacer of 8mm length or more regarding insulation.
And do not use press-fitting bush.
- ※ Point A, Point B are thermometry points. Please refer to Instruction Manual 3.

I/O Connector	Mating connector	Terminal
CN1	1-1123724-3	1-1123722-5 Chain 1123721-1
		Loose 1318912-1
CN2	1-1123723-4	1-1123722-4 Chain 1123721-1
		Loose 1318912-1

(Mfr:Tyco Electronics)

- ※ I/O Connector is Mfr. Tyco Electronics
- ※ Option:-J1:(J.S.T) connector type. Refer to Instruction Manual 6.

<PIN CONNECTION>

CN1		CN2	
Pin No.	Input	Pin No.	Output
1	AC(L)	1, 2	-V
2		3, 4	+V
3	AC(N)		
4			
5	FG		

- ※ Tolerance : ± 1 [± 0.04]
- ※ Weight : 165g max (with chassis & cover : 325g max)
- ※ PCB material / thickness : CEM3 / 1.6mm
- ※ Optional chassis and cover material : Electric galvanizing steel board.
- ※ Dimensions in mm, []=inches
- ※ Mounting torque (Mounting hole of chassis) : 0.6N · m (6.3kgf · cm) max

- ※ Keep drawing current per pin below 5A for CN2.

LFA75F

LF A 75 F -□ -□

① ② ③ ④ ⑤ ⑥

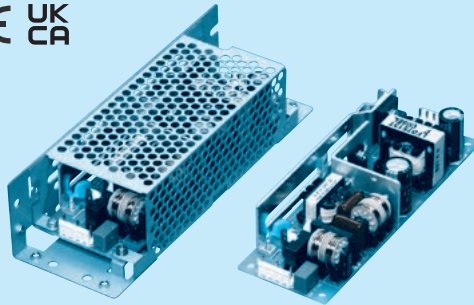

Example recommended EMI/EMC filter
NAC-04-472



High voltage pulse noise type : NAP series
Low leakage current type : NAM series
* A higher current rating EMI/EMC filter may be recommended in view of the other devices that could be connected in parallel with the power supply.

- ① Series name
- ② Single output
- ③ Output wattage
- ④ Universal input
- ⑤ Output voltage
- ⑥ Optional
- C : with Coating
- G : Low leakage current
- J1 : VH(J.S.T.)connector type
- S : with Chassis
- SN : with Chassis & cover
- Y : with Potentiometer

Specification is changed at option, refer to Instruction Manual.

This power supply is manufactured by SMD technology. The stress to P.C.B like twisting or bending causes the defect of the unit, so handle the unit with care.
*Make sure necessary tests will be carried out on your end equipment with the power supply installed in accordance with any required EMC/EMI regulations.

MODEL	LFA75F-3R3-Y	LFA75F-5	LFA75F-12	LFA75F-15	LFA75F-24	LFA75F-36	LFA75F-48
MAX OUTPUT WATTAGE[W]	49.5	75	75.6	75	76.8	75.6	76.8
DC OUTPUT	3.3V 15A	5V 15A	12V 6.3A	15V 5A	24V 3.2A	36V 2.1A	48V 1.6A

SPECIFICATIONS

	MODEL	LFA75F-3R3-Y	LFA75F-5	LFA75F-12	LFA75F-15	LFA75F-24	LFA75F-36	LFA75F-48	
INPUT	VOLTAGE[V]	AC85 - 264 1 φ (Refer to "Derating", Instruction Manual 1 and 3) *3							
	CURRENT[A]	ACIN 100V	0.70typ (Io=100%)	1.00typ (Io=100%)					
		ACIN 200V	0.40typ (Io=100%)	0.50typ (Io=100%)					
	FREQUENCY[Hz]	50 / 60 (47 - 63)							
	EFFICIENCY[%]	ACIN 100V	73.5typ	78.0typ	81.5typ	81.5typ	82.5typ	82.5typ	82.5typ
		ACIN 200V	75.0typ	80.0typ	83.0typ	83.0typ	84.5typ	84.5typ	84.5typ
	POWER FACTOR (Io=100%)	ACIN 100V	0.96typ	0.97typ					
		ACIN 200V	0.83typ	0.90typ					
INRUSH CURRENT[A]	ACIN 100V	15typ (Io=100%) (At cold start) (Ta=25°C)							
	ACIN 200V	30typ (Io=100%) (At cold start) (Ta=25°C)							
LEAKAGE CURRENT[mA]	0.40 / 0.75max (ACIN 100V / 240V 60Hz, Io=100%, According to IEC62368-1 and DEN-AN)								
OUTPUT	VOLTAGE[V]	3.3	5	12	15	24	36	48	
	CURRENT[A]	15.0	15.0	6.3	5.0	3.2	2.1	1.6	
	LINE REGULATION[mV] *4	20max	20max	48max	60max	96max	144max	192max	
	LOAD REGULATION[mV] *4	40max	40max	100max	120max	150max	240max	240max	
	RIPPLE[mVp-p]	0 to +50°C *1	80max	80max	120max	120max	120max	150max	150max
		-10 -0°C *1	140max	140max	160max	160max	160max	200max	200max
	RIPPLE NOISE[mVp-p]	0 to +50°C *1	120max	120max	150max	150max	150max	250max	250max
		-10 -0°C *1	160max	160max	180max	180max	180max	300max	300max
	TEMPERATURE REGULATION[mV]	0 to +50°C	50max	50max	120max	150max	240max	360max	480max
		-10 to +50°C	60max	60max	150max	180max	290max	450max	600max
	DRIFT[mV] *2	20max	20max	48max	60max	96max	144max	192max	
	START-UP TIME[ms]	350typ (ACIN 100V, Io=100%)							
HOLD-UP TIME[ms]	20typ (ACIN 100V, Io=100%)								
OUTPUT VOLTAGE ADJUSTMENT RANGE[V]	2.85 to 3.63	Fixed ("Y"option is available for adjusting output voltage between ±10%)							
OUTPUT VOLTAGE SETTING[V]	3.30 to 3.40	4.90 to 5.30	11.50 to 12.50	14.40 to 15.60	23.00 to 25.00	34.50 to 37.50	46.00 to 50.00		
PROTECTION CIRCUIT AND OTHERS	OVERCURRENT PROTECTION	Works over 105% of rating and recovers automatically							
	OVERVOLTAGE PROTECTION	4.00 to 5.25	5.75 to 7.00	13.80 to 16.80	17.25 to 21.00	27.60 to 33.60	41.40 to 50.40	55.20 to 67.20	
	OPERATING INDICATION	Not provided							
	REMOTE SENSING	Not provided							
ISOLATION	REMOTE ON/OFF	Not provided							
	INPUT-OUTPUT	AC3,000V 1minute, Cutoff current = 10mA, DC500V 50MΩ min (At Room Temperature)							
	INPUT-FG	AC2,000V 1minute, Cutoff current = 10mA, DC500V 50MΩ min (At Room Temperature)							
ENVIRONMENT	OUTPUT-FG	AC500V 1minute, Cutoff current = 25mA, DC500V 50MΩ min (At Room Temperature)							
	OPERATING TEMP., HUMID. AND ALTITUDE	-10 to +70°C, 20 - 90%RH (Non condensing) (Refer to "Derating", Instruction Manual 3), 3,000m (10,000feet) max *3							
	STORAGE TEMP., HUMID. AND ALTITUDE	-20 to +75°C, 20 - 90%RH (Non condensing), 9,000m (30,000feet) max							
	VIBRATION	10 - 55Hz, 19.6m/s ² (2G), 3minutes period, 60minutes each along X, Y and Z axis							
SAFETY AND NOISE REGULATIONS	IMPACT	196.1m/s ² (20G), 11ms, once each X, Y and Z axis							
	AGENCY APPROVALS	UL60950-1, C-UL (CSA60950-1), EN62368-1 Complies with DEN-AN							
	CONDUCTED NOISE	Complies with FCC-B, VCCI-B, CISPR-B, EN55011-B, EN55022-B							
OTHERS	HARMONIC ATTENUATOR	Complies with IEC61000-3-2 (Class A) *5							
	CASE SIZE/WEIGHT	50 X 33.5 X 150mm [1.97 X 1.32 X 5.91 inches] (W X H X D) / 230g max (with chassis & cover : 440g max)							
	COOLING METHOD	Convection (Refer to "Derating", Instruction Manual 3) *3							

*1 This is the value that measured on measuring board with capacitor of 22 μF at 150mm from output terminal.
Measured by 20MHz oscilloscope or Ripple-Noise meter (Equivalent to KEISOKU-GIKEN: RM103).

*2 Drift is the change in DC output for an eight hour period after a half-hour warm-up at 25°C, with the input voltage held constant at the rated input/output.

*3 Derating is required.

*4 Please contact us about dynamic load and input response.

*5 Please contact us about another class.

* To meet the specifications. Do not operate over-loaded condition.

* Parallel operation is not possible.

* Derating is required when operated with chassis and cover.

* Sound noise may be generated by power supply in case of pulse load.

Block diagram

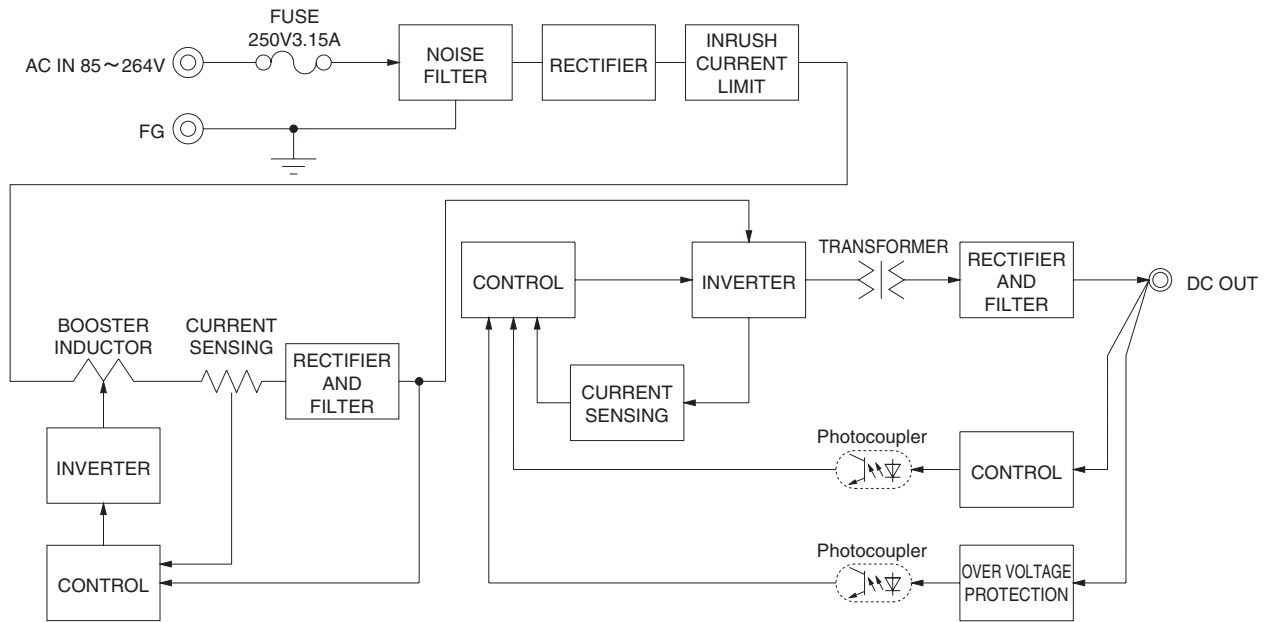

LFA

External view

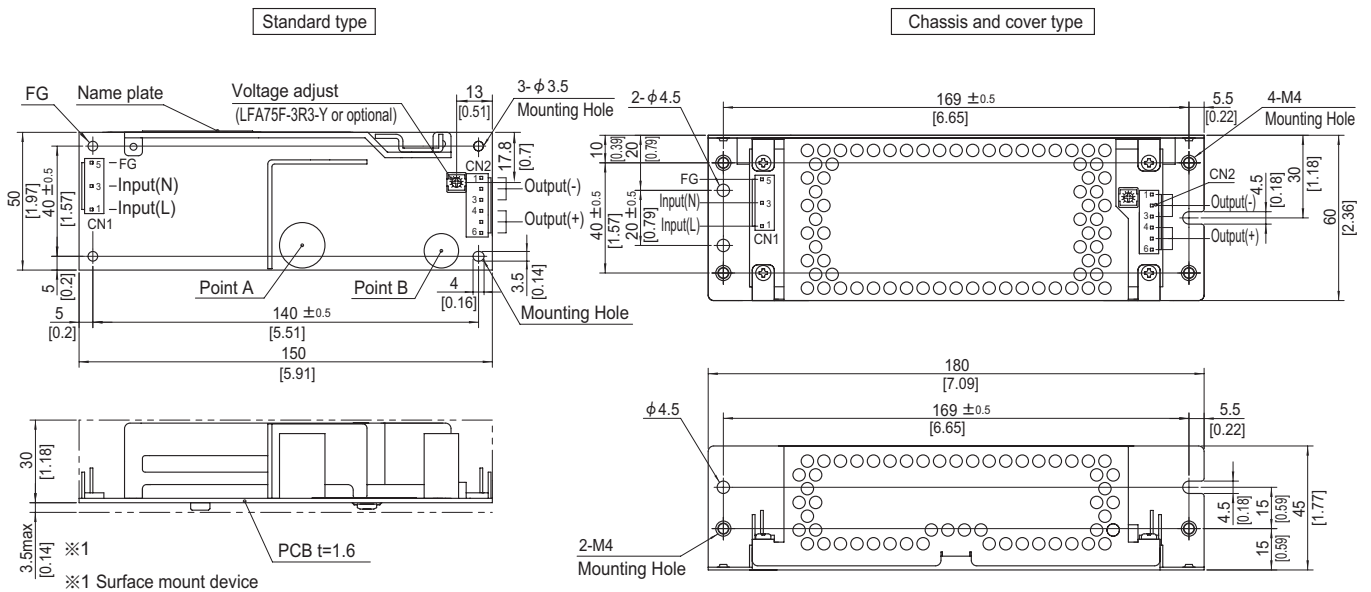

- ※ 4 Mounting holes are existing.
- ※ The back side of P.C.B. of the power supply is assembled some SMDs.
Be attention not to bump against the attached area by vibration.
- ※ Use the spacer of 8mm length or more regarding insulation.
And do not use press-fitting bush.
- ※ Point A, Point B are thermometry points. Please refer to Instruction Manual 3.

I/O Connector	Mating connector	Terminal
CN1	1-1123724-3	Chain 1123721-1
		Loose 1318912-1
CN2	1-1123723-6	Chain 1123721-1
		Loose 1318912-1

(Mfr:Tyco Electronics)

- ※ I/O Connector is Mfr. Tyco Electronics
- ※ Option:-J1:(J.S.T) connector type. Refer to Instruction Manual 6.

<PIN CONNECTION>

CN1		CN2	
Pin No.	Input	Pin No.	Output
1	AC(L)	1 to 3	-V
2		4 to 6	+V
3	AC(N)		
4			
5	FG		

- ※ Tolerance : ± 1 [± 0.04]
- ※ Weight : 230g max (with chassis & cover : 440g max)
- ※ PCB material / thickness : CEM3 / 1.6mm
- ※ Optional chassis and cover material : Electric galvanizing steel board.
- ※ Dimensions in mm, []=inches
- ※ Mounting torque (Mounting hole of chassis) : $1.5N \cdot m$ (16kgf \cdot cm) max

※ Keep drawing current per pin below 5A for CN2.

LFA100F

LF A 100 F -□ -□
 ① ② ③ ④ ⑤ ⑥

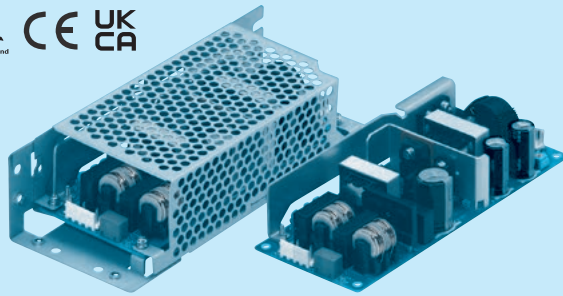
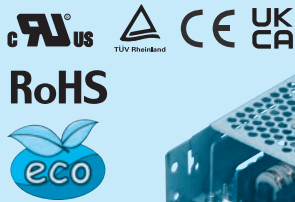

Example recommended EMI/EMC filter
NAC-04-472



High voltage pulse noise type : NAP series
 Low leakage current type : NAM series
 * A higher current rating EMI/EMC filter may be recommended in view of the other devices that could be connected in parallel with the power supply.

- ① Series name
- ② Single output
- ③ Output wattage
- ④ Universal input
- ⑤ Output voltage
- ⑥ Optional *1
- C : with Coating
- G : Low leakage current
- H : with the function to be acceptable to output peak current (only 24V)
- J1 : VH(J.S.T.)connector type
- R : with Remote ON/OFF
- R2 : with Remote ON/OFF
- S : with Chassis
- SN : with Chassis & cover
- Y : with Potentiometer

This power supply is manufactured by SMD technology. The stress to P.C.B like twisting or bending causes the defect of the unit, so handle the unit with care.
 * Make sure necessary tests will be carried out on your end equipment with the power supply installed in accordance with any required EMC/EMI regulations.

Please refer to Instruction manual 6.

MODEL	LFA100F-3R3-Y	LFA100F-5-Y	LFA100F-12	LFA100F-15	LFA100F-24	LFA100F-24-H	LFA100F-36	LFA100F-48
MAX OUTPUT WATTAGE[W]	66	100	102	100.5	103.2	103.2 (129.6)	100.8	100.8
DC OUTPUT	3.3V 20A	5V 20A	12V 8.5A	15V 6.7A	24V 4.3A	24V 4.3 (5.4)A	36V 2.8A	48V 2.1A

SPECIFICATIONS

	MODEL	LFA100F-3R3-Y	LFA100F-5-Y	LFA100F-12	LFA100F-15	LFA100F-24	LFA100F-24-H	LFA100F-36	LFA100F-48	
INPUT	VOLTAGE[V]	AC85 - 264 1 φ (Refer to "Derating", Instruction Manual 1 and 3) *4								
	CURRENT[A]	ACIN 100V	0.9typ (Io=100%)	1.3typ (Io=100%)						
		ACIN 200V	0.5typ (Io=100%)	0.7typ (Io=100%)						
	FREQUENCY[Hz]	50 / 60 (47 - 63)								
	EFFICIENCY[%]	ACIN 100V	77.0typ	82.0typ	82.0typ	83.0typ	84.0typ	84.0typ	84.0typ	84.5typ
		ACIN 200V	79.0typ	84.0typ	84.5typ	85.5typ	87.0typ	87.0typ	87.0typ	87.0typ
	POWER FACTOR (Io=100%)	ACIN 100V	0.98typ	0.99typ						
ACIN 200V		0.92typ	0.95typ							
INRUSH CURRENT[A]	ACIN 100V	15typ (Io=100%) (At cold start) (Ta=25°C)								
	ACIN 200V	30typ (Io=100%) (At cold start) (Ta=25°C)								
LEAKAGE CURRENT[mA]	0.40 / 0.75max (ACIN 100V / 240V 60Hz, Io=100%, According to IEC62368-1 and DEN-AN)									
OUTPUT	VOLTAGE[V]	3.3	5	12	15	24	24	36	48	
	CURRENT[A]	20	20	8.5	6.7	4.3	4.3 (Peak 5.4)	2.8	2.1	
	LINE REGULATION[mV]	20max	20max	48max	60max	96max	96max	144max	192max	
	LOAD REGULATION[mV]	40max	40max	100max	120max	150max	150max	240max	240max	
	RIPPLE [mVp-p]	0 to +50°C *2	80max	80max	120max	120max	120max	240max	150max	150max
		-10 - 0°C *2	140max	140max	160max	160max	160max	320max	200max	200max
	RIPPLE NOISE [mVp-p]	0 to +50°C *2	120max	120max	150max	150max	150max	300max	250max	250max
		-10 - 0°C *2	160max	160max	180max	180max	180max	360max	300max	300max
	TEMPERATURE REGULATION [mV]	0 to +50°C	50max	50max	120max	150max	240max	240max	360max	480max
		-10 to +50°C	60max	60max	150max	180max	290max	290max	450max	600max
	DRIFT [mV]	20max	20max	48max	60max	96max	96max	144max	192max	
	START-UP TIME [ms]	350typ (ACIN 100V, Io=100%)								
	HOLD-UP TIME [ms]	20typ (ACIN 100V, Io=100%)								
OUTPUT VOLTAGE ADJUSTMENT RANGE [V]	2.85 to 3.63 / 4.50 to 5.50 / Fixed ("Y" option is available for adjusting output voltage)									
OUTPUT VOLTAGE SETTING [V]	3.30 to 3.40	5.00 to 5.15	11.50 to 12.50	14.40 to 15.60	23.00 to 25.00	23.00 to 25.00	34.50 to 37.50	46.00 to 50.00		
PROTECTION CIRCUIT AND OTHERS	OVERCURRENT PROTECTION	Works over 105% of rating (works over 101% of peak current at option -H) and recovers automatically								
	OVERVOLTAGE PROTECTION	4.00 to 5.25	5.75 to 7.00	13.80 to 16.80	17.25 to 21.00	27.60 to 33.60	27.60 to 33.60	41.40 to 50.40	55.20 to 67.20	
	OPERATING INDICATION	Not provided								
	REMOTE SENSING	Not provided								
	REMOTE ON/OFF	Option (Refer to Instruction Manual)								
ISOLATION	INPUT-OUTPUT-RC	*6 AC3,000V 1minute, Cutoff current = 10mA, DC500V 50MΩ min (At Room Temperature)								
	INPUT-FG	*6 AC2,000V 1minute, Cutoff current = 10mA, DC500V 50MΩ min (At Room Temperature)								
	OUTPUT-RC-FG	*6 AC500V 1minute, Cutoff current = 25mA, DC500V 50MΩ min (At Room Temperature)								
	OUTPUT-RC	*6 AC100V 1minute, Cutoff current = 25mA, DC100V 10MΩ min (At Room Temperature)								
ENVIRONMENT	OPERATING TEMP., HUMID. AND ALTITUDE *4	-10 to +70°C, 20 - 90%RH (Non condensing) (Refer to "Derating", Instruction Manual 3), 3,000m (10,000feet) max								
	STORAGE TEMP., HUMID. AND ALTITUDE	-20 to +75°C, 20 - 90%RH (Non condensing), 9,000m (30,000feet) max								
	VIBRATION	10 - 55Hz, 19.6m/s ² (2G), 3minutes period, 60minutes each along X, Y and Z axis								
	IMPACT	196.1m/s ² (20G), 11ms, once each X, Y and Z axis								
SAFETY AND NOISE REGULATIONS	AGENCY APPROVALS	UL60950-1, C-UL (CSA60950-1), EN62368-1 Complies with DEN-AN								
	CONDUCTED NOISE	Complies with FCC-B, VCCI-B, CISPR-B, EN55011-B, EN55022-B								
	HARMONIC ATTENUATOR	Complies with IEC61000-3-2 (Class A) *8								
OTHERS	CASE SIZE/WEIGHT	62 X 33.5 X 155mm [2.44 X 1.32 X 6.10 inches] (W X H X D) / 280g max (with chassis & cover : 480g max)								
	COOLING METHOD	Convection (Refer to "Derating", Instruction Manual 3) *4								

*1 Specification is changed at option, refer to Instruction Manual.
 *2 This is the value that measured on measuring board with capacitor of 22 μF at 150mm from output terminal.
 *3 Drift is the change in DC output for an eight hour period after a half-hour warm-up at 25°C, with the input voltage held constant
 *4 at the rated input/output.
 *5 () means peak current. There is a possibility that an internal device is damaged when the specification is exceeded. Please contact us about the detail.
 *6 Applicable when Remote ON/OFF (optional) is added.
 *7 Please contact us about dynamic load and input response.
 *8 Please contact us about another class.
 *9 To meet the specifications. Do not operate over-loaded condition.
 *10 Parallel operation is not possible.
 *11 Derating is required when operated with chassis and cover.
 *12 Sound noise may be generated by power supply in case of pulse load.

Block diagram

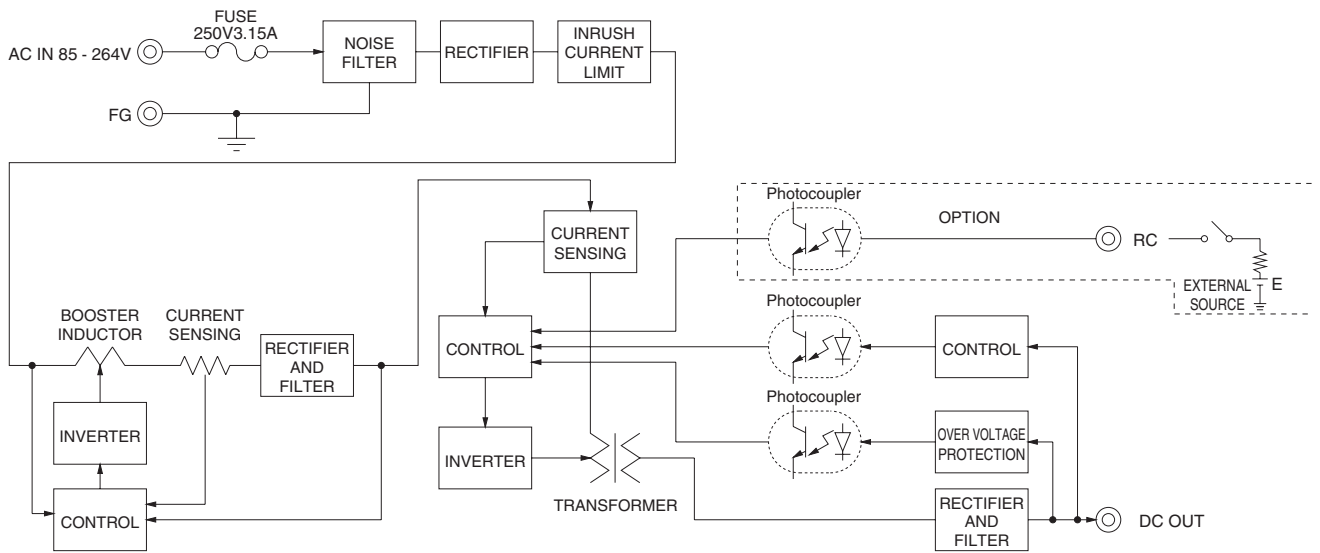

External view

※ External size of option is different from standard model.

Standard type

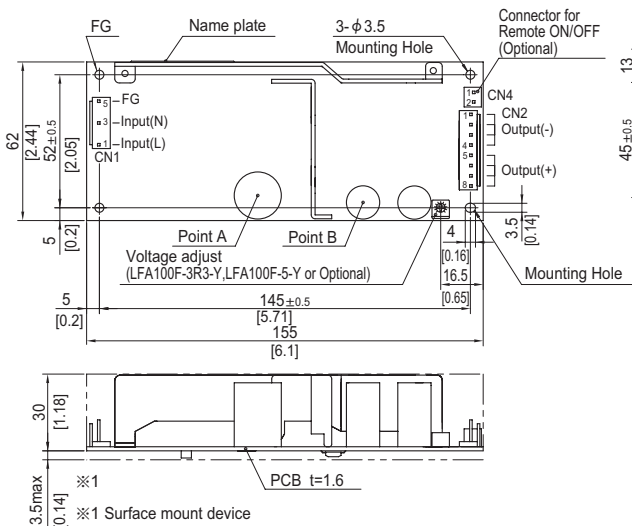

Chassis and cover type

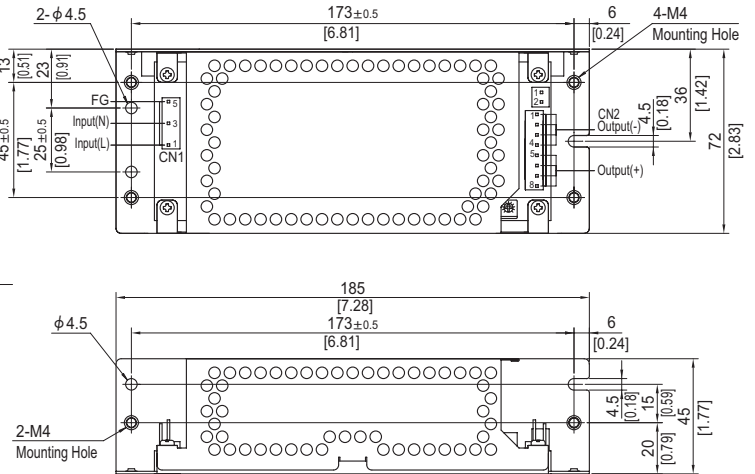

- ※ 4 Mounting holes are existing.
- ※ The back side of P.C.B. of the power supply is assembled some SMDs.
Be attention not to bump against the attached area by vibration.
- ※ Use the spacer of 8mm length or more regarding insulation.
And do not use press-fitting bush.
- ※ Point A, Point B are thermometry points. Please refer to Instruction Manual 3.

I/O Connector	Mating connector	Terminal
CN1	1-1123724-3	Chain Loose 1123721-1
	1-1123722-5	Chain Loose 1318912-1
CN2	1-1123723-8	Chain Loose 1123721-1
	1-1123722-8	Chain Loose 1318912-1

(Mfr:Tyco Electronics)

- ※ I/O Connector is Mfr. Tyco Electronics
- ※ Option:-J1:VH(J.S.T) connector type.

<PIN CONNECTION>

CN1		CN2	
Pin No.	Input	Pin No.	Output
1	AC(L)	1 to 4	-V
2		5 to 8	+V
3	AC(N)		
4			
5	FG		

※ Keep drawing current per pin below 5A for CN2.

- ※ Tolerance : ± 1 [± 0.04]
- ※ Weight : 280g max (with chassis & cover : 480g max)
- ※ PCB material : CEM3
- ※ Optional chassis and cover material : Electric galvanizing steel board.
- ※ Dimensions in mm, []=inches
- ※ Mounting torque (Mounting hole of chassis) : $1.5N \cdot m$ (16kgf · cm) max

Connector type

CN4 Option (Mfr:J.S.T)

PIN No.	Contents
1	RC(+)
2	RC(-)

Barrier strip type

Model B2B-XH-A
Mating Connector (Terminal)
XHP-2
(BXH-001T-P0.6
or SXH-001T-P0.6)

LFA150F

LF A 150 F -□ -□
 ① ② ③ ④ ⑤ ⑥

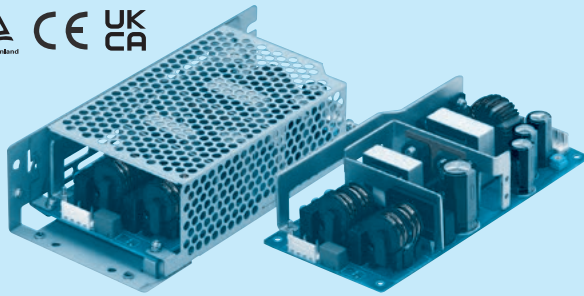
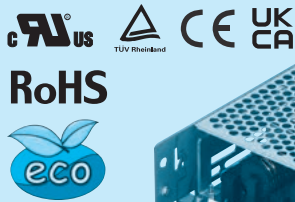

Example recommended EMI/EMC filter
NAC-04-472



High voltage pulse noise type : NAP series
 Low leakage current type : NAM series
 * A higher current rating EMI/EMC filter may be recommended in view of the other devices that could be connected in parallel with the power supply.

- ① Series name
 - ② Single output
 - ③ Output wattage
 - ④ Universal input
 - ⑤ Output voltage
 - ⑥ Optional *1
 - C : with Coating
 - G : Low leakage current
 - H : with the function to be acceptable to output peak current (only 24V)
 - J1 : VH(J.S.T.)connector type
 - R : with Remote ON/OFF
 - R2 : with Remote ON/OFF
 - S : with Chassis
 - SN : with Chassis & cover
 - Y : with Potentiometer
- Please refer to Instruction manual 6.

This power supply is manufactured by SMD technology. The stress to P.C.B like twisting or bending causes the defect of the unit, so handle the unit with care.
 * Make sure necessary tests will be carried out on your end equipment with the power supply installed in accordance with any required EMC/EMI regulations.

MODEL	LFA150F-3R3-Y	LFA150F-5-Y	LFA150F-12	LFA150F-15	LFA150F-24	LFA150F-24-H	LFA150F-36	LFA150F-48
MAX OUTPUT WATTAGE[W]	99	150	150	150	151.2	151.2 (189.6)	151.2	153.6
DC OUTPUT	3.3V 30A	5V 30A	12V 12.5A	15V 10A	24V 6.3A	24V 6.3 (7.9)A	36V 4.2A	48V 3.2A

SPECIFICATIONS

	MODEL	LFA150F-3R3-Y	LFA150F-5-Y	LFA150F-12	LFA150F-15	LFA150F-24	LFA150F-24-H	LFA150F-36	LFA150F-48	
INPUT	VOLTAGE[V]	AC85 - 264 1 φ (Refer to "Derating", Instruction Manual 1 and 3) *4								
	CURRENT[A]	ACIN 100V	1.4typ (Io=100%)	2.0typ (Io=100%)						
		ACIN 200V	0.7typ (Io=100%)	1.0typ (Io=100%)						
	FREQUENCY[Hz]	50 / 60 (47 - 63)								
	EFFICIENCY[%]	ACIN 100V	80.0typ	82.5typ	82.5typ	84.0typ	85.0typ	85.0typ	85.0typ	85.5typ
		ACIN 200V	82.0typ	85.5typ	85.0typ	86.5typ	87.5typ	87.5typ	87.5typ	88.0typ
	POWER FACTOR (Io=100%)	ACIN 100V	0.98typ	0.99typ						
ACIN 200V		0.92typ	0.95typ							
INRUSH CURRENT[A]	ACIN 100V	15typ (Io=100%) (At cold start) (Ta=25°C)								
	ACIN 200V	30typ (Io=100%) (At cold start) (Ta=25°C)								
LEAKAGE CURRENT[mA]	0.40 / 0.75max (ACIN 100V / 240V 60Hz, Io=100%, According to IEC62368-1 and DEN-AN)									
OUTPUT	VOLTAGE[V]	3.3	5	12	15	24	24	36	48	
	CURRENT[A]	30	30	12.5	10	6.3	6.3 (Peak 7.9)	4.2	3.2	
	LINE REGULATION[mV]	20max	20max	48max	60max	96max	96max	144max	192max	
	LOAD REGULATION[mV]	40max	40max	100max	120max	150max	150max	240max	240max	
	RIPPLE[mVp-p]	0 to +40°C *2	80max	80max	120max	120max	120max	240max	150max	150max
		-10 - 0°C *2	140max	140max	160max	160max	160max	320max	200max	200max
	RIPPLE NOISE[mVp-p]	0 to +40°C *2	120max	120max	150max	150max	150max	300max	250max	250max
		-10 - 0°C *2	160max	160max	180max	180max	180max	360max	300max	300max
	TEMPERATURE REGULATION[mV]	0 to +40°C	50max	50max	120max	150max	240max	240max	360max	480max
		-10 to +40°C	60max	60max	150max	180max	290max	290max	450max	600max
	DRIFT[mV]	20max	20max	48max	60max	96max	96max	144max	192max	
	START-UP TIME[ms]	350typ (ACIN 100V, Io=100%)								
	HOLD-UP TIME[ms]	20typ (ACIN 100V, Io=100%)								
OUTPUT VOLTAGE ADJUSTMENT RANGE[V]	2.85 to 3.63 / 4.50 to 5.50 / Fixed ("Y" option is available for adjusting output voltage)									
OUTPUT VOLTAGE SETTING[V]	3.30 to 3.40	5.00 to 5.15	11.50 to 12.50	14.40 to 15.60	23.00 to 25.00	23.00 to 25.00	34.50 to 37.50	46.00 to 50.00		
PROTECTION CIRCUIT AND OTHERS	OVERCURRENT PROTECTION	Works over 105% of rating (works over 101% of peak current at option -H) and recovers automatically								
	OVERVOLTAGE PROTECTION	4.00 to 5.25	5.75 to 7.00	13.80 to 16.80	17.25 to 21.00	27.60 to 33.60	27.60 to 33.60	41.40 to 50.40	55.20 to 67.20	
	OPERATING INDICATION	Not provided								
	REMOTE SENSING	Not provided								
	REMOTE ON/OFF	Option (Refer to Instruction Manual)								
ISOLATION	INPUT-OUTPUT-RC	AC3,000V 1minute, Cutoff current = 10mA, DC500V 50MΩ min (At Room Temperature)								
	INPUT-FG	AC2,000V 1minute, Cutoff current = 10mA, DC500V 50MΩ min (At Room Temperature)								
	OUTPUT-RC-FG	AC500V 1minute, Cutoff current = 25mA, DC500V 50MΩ min (At Room Temperature)								
	OUTPUT-RC	AC100V 1minute, Cutoff current = 25mA, DC100V 10MΩ min (At Room Temperature)								
ENVIRONMENT	OPERATING TEMP., HUMID. AND ALTITUDE *4	-10 to +70°C, 20 - 90%RH (Non condensing) (Refer to "Derating", Instruction Manual 3), 3,000m (10,000feet) max								
	STORAGE TEMP., HUMID. AND ALTITUDE	-20 to +75°C, 20 - 90%RH (Non condensing), 9,000m (30,000feet) max								
	VIBRATION	10 - 55Hz, 19.6m/s ² (2G), 3minutes period, 60minutes each along X, Y and Z axis								
	IMPACT	196.1m/s ² (20G), 11ms, once each X, Y and Z axis								
SAFETY AND NOISE REGULATIONS	AGENCY APPROVALS	UL60950-1, C-UL (CSA60950-1), EN62368-1 Complies with DEN-AN								
	CONDUCTED NOISE	Complies with FCC-B, VCCI-B, CISPR-B, EN55011-B, EN55022-B								
	HARMONIC ATTENUATOR	Complies with IEC61000-3-2 (Class A) *8								
OTHERS	CASE SIZE/WEIGHT	75 X 37.0 X 160mm [2.95 X 1.46 X 6.30 inches] (W X H X D) / 390g max (with chassis & cover : 650g max)								
	COOLING METHOD	Convection (Refer to "Derating", Instruction Manual 3) *4								

*1 Specification is changed at option, refer to Instruction Manual.
 *2 This is the value that measured on measuring board with capacitor of 22 μF at 150mm from output terminal.
 *3 Drift is the change in DC output for an eight hour period after a half-hour warm-up at 25°C, with the input voltage held constant
 *4 at the rated input/output.
 *5 Derating is required.
 *6 Applicable when remote control (optional) is added.
 *7 Please contact us about dynamic load and input response.
 *8 Please contact us about another class.
 *9 To meet the specifications. Do not operate over-loaded condition.
 *10 Parallel operation is not possible.
 *11 Derating is required when operated with chassis and cover.
 *12 Sound noise may be generated by power supply in case of pulse load.

Block diagram

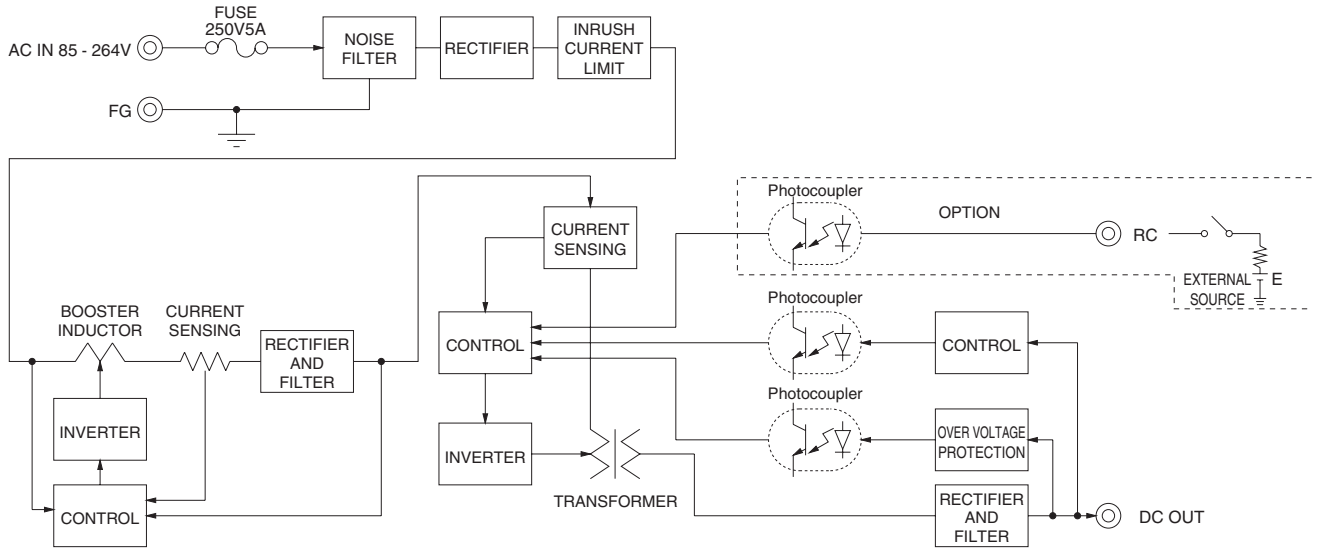

External view

※ External size of option is different from standard model.

Standard type

Chassis and cover type

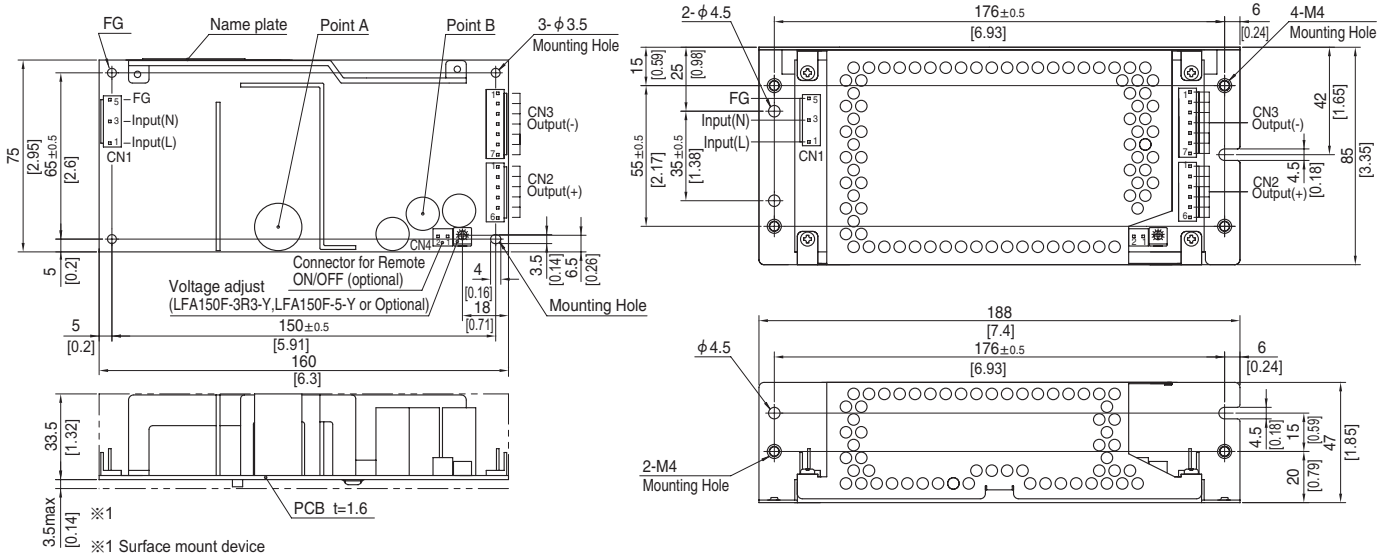

- ※ 4 Mounting holes are existing.
- ※ The back side of P.C.B. of the power supply is assembled some SMDs.
Be attention not to bump against the attached area by vibration.
- ※ Use the spacer of 8mm length or more regarding insulation.
And do not use press-fitting bush.
- ※ Point A, Point B are thermometry points. Please refer to Instruction Manual 3.

I/O Connector	Mating connector	Terminal
CN1	1-1123724-3	1123721-1
		1318912-1
CN2	1-1123723-6	1123721-1
		1318912-1
CN3	1-1123723-7	1123721-1
		1318912-1

(Mfr: Tyco Electronics)

- ※ I/O Connector is Mfr. Tyco Electronics
- ※ Option: -J1:VH(J.S.T) connector type.

<PIN CONNECTION>

CN1		CN2		CN3	
Pin No.	Input	Pin No.	Output	Pin No.	Output
1	AC(L)	1 to 6	+V	1 to 7	-V
2					
3	AC(N)				
4					
5	FG				

※ Keep drawing current per pin below 5A for CN2,CN3.

- ※ Tolerance : ± 1 [± 0.04]
- ※ Weight : 390g max (with chassis & cover : 650g max)
- ※ PCB material : CEM3
- ※ Optional chassis and cover material : Electric galvanizing steel board.
- ※ Dimensions in mm, []=inches
- ※ Mounting torque (Mounting hole of chassis) : 1.5N · m (16kgf · cm) max

Connector type

CN4 Option (Mfr:J.S.T)

PIN No.	Contents
1	RC(+)
2	RC(-)

Barrier strip type

Model B2B-XH-A
Mating Connector (Terminal)
XHP-2
(BXH-001T-P0.6
or SXH-001T-P0.6)

LFA240F

LF A 240 F -□ -□

① ② ③ ④ ⑤ ⑥

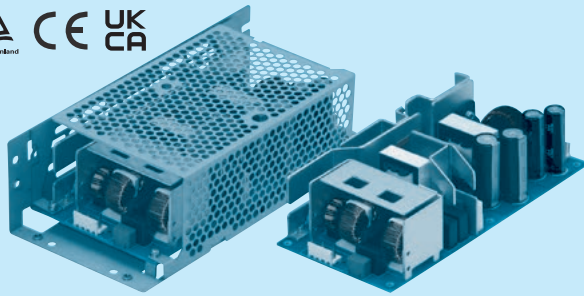
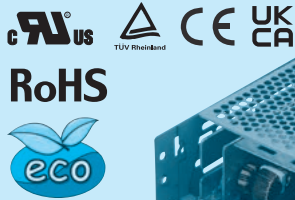

Example recommended EMI/EMC filter
NAC-06-472



High voltage pulse noise type : NAP series
Low leakage current type : NAM series
* A higher current rating EMI/EMC filter may be recommended in view of the other devices that could be connected in parallel with the power supply.

- ① Series name
- ② Single output
- ③ Output wattage
- ④ Universal input
- ⑤ Output voltage
- ⑥ Optional *1
- C : with Coating
- G : Low leakage current
- H : with the function to be acceptable to output peak current (only 24V)
- J1 : VH(J.S.T.)connector type
- R : with Remote ON/OFF
- R2 : with Remote ON/OFF
- S : with Chassis
- SN : with Chassis & cover
- T : Vertical terminal block
- Y : with Potentiometer

This power supply is manufactured by SMD technology. The stress to P.C.B like twisting or bending causes the defect of the unit, so handle the unit with care.
* Make sure necessary tests will be carried out on your end equipment with the power supply installed in accordance with any required EMC/EMI regulations.

Please refer to Instruction manual 6.

MODEL	LFA240F-24	LFA240F-24-H	LFA240F-36	LFA240F-48
MAX OUTPUT WATTAGE[W]	240	240 (300)	241.2	240
DC OUTPUT	24V 10A	24V 10 (12.5)A	36V 6.7A	48V 5A

SPECIFICATIONS

	MODEL	LFA240F-24	LFA240F-24-H	LFA240F-36	LFA240F-48	
INPUT	VOLTAGE[V]	AC85 - 264 1φ (Refer to "Derating", Instruction Manual 1 and 3) *4				
	CURRENT[A]	ACIN 100V	3.3typ (Io=100%)			
		ACIN 200V	1.7typ (Io=100%)			
	FREQUENCY[Hz]	50 / 60 (47 - 63)				
	EFFICIENCY[%]	ACIN 100V	84.5typ	84.5typ	84.5typ	84.5typ
		ACIN 200V	87.5typ	87.5typ	87.5typ	87.5typ
	POWER FACTOR (Io=100%)	ACIN 100V	0.99typ			
ACIN 200V		0.95typ				
INRUSH CURRENT[A]	ACIN 100V	15 / 30typ (Io=100%) (Primary inrush current /Secondary inrush current) (More than 3 sec. to re-start)				
	ACIN 200V	30 / 30typ (Io=100%) (Primary inrush current /Secondary inrush current) (More than 3 sec. to re-start)				
LEAKAGE CURRENT[mA]	0.40 / 0.75max (ACIN 100V / 240V 60Hz, Io=100%, According to IEC62368-1 and DEN-AN)					
OUTPUT	VOLTAGE[V]	24	24	36	48	
	CURRENT[A]	10	10 (Peak12.5)	6.7	5	
	LINE REGULATION[mV]	96max	96max	144max	192max	
	LOAD REGULATION[mV]	150max	150max	240max	240max	
	RIPPLE[mVp-p]	0 to +40°C *2	120max	240max	150max	150max
		-10 -0°C *2	160max	320max	200max	200max
	RIPPLE NOISE[mVp-p]	0 to +40°C *2	150max	300max	250max	250max
		-10 -0°C *2	180max	360max	300max	300max
	TEMPERATURE REGULATION[mV]	0 to +40°C	240max	240max	360max	480max
		-10 to +40°C	290max	290max	450max	600max
	DRIFT[mV]	96max	96max	144max	192max	
	START-UP TIME[ms]	350typ (ACIN 100V, Io=100%)				
	HOLD-UP TIME[ms]	20typ (ACIN 100V, Io=100%)				
	OUTPUT VOLTAGE ADJUSTMENT RANGE[V]	Fixed ("Y"option is available for adjusting output voltage)				
OUTPUT VOLTAGE SETTING[V]	23.00 to 25.00	23.00 to 25.00	34.50 to 37.50	46.00 to 50.00		
PROTECTION CIRCUIT AND OTHERS	OVERCURRENT PROTECTION	Works over 105% of rating (works over 101% of peak current at option -H) and recovers automatically				
	OVERVOLTAGE PROTECTION	27.60 to 33.60	27.60 to 33.60	41.40 to 50.40	55.20 to 67.20	
	OPERATING INDICATION	Not provided				
	REMOTE SENSING	Not provided				
	REMOTE ON/OFF	Option (Refer to Instruction Manual)				
ISOLATION	INPUT-OUTPUT-RC	*6 AC3,000V 1minute, Cutoff current = 10mA, DC500V 50MΩ min (At Room Temperature)				
	INPUT-FG	AC2,000V 1minute, Cutoff current = 10mA, DC500V 50MΩ min (At Room Temperature)				
	OUTPUT-RC-FG	*6 AC500V 1minute, Cutoff current = 25mA, DC500V 50MΩ min (At Room Temperature)				
	OUTPUT-RC	*6 AC100V 1minute, Cutoff current = 25mA, DC100V 10MΩ min (At Room Temperature)				
ENVIRONMENT	OPERATING TEMP.,HUMID.AND ALTITUDE *4	-10 to +70°C, 20 - 90%RH (Non condensing) (Refer to "Derating", Instruction Manual 3), 3,000m (10,000feet) max				
	STORAGE TEMP.,HUMID.AND ALTITUDE	-20 to +75°C, 20 - 90%RH (Non condensing), 9,000m (30,000feet) max				
	VIBRATION	10 - 55Hz, 19.6m/s ² (2G), 3minutes period, 60minutes each along X, Y and Z axis				
	IMPACT	196.1m/s ² (20G), 11ms, once each X, Y and Z axis				
SAFETY AND NOISE REGULATIONS	AGENCY APPROVALS	UL60950-1, C-UL (CSA60950-1), EN62368-1 Complies with DEN-AN				
	CONDUCTED NOISE	Complies with FCC-B, VCCI-B, CISPR-B, EN55011-B, EN55022-B				
	HARMONIC ATTENUATOR	Complies with IEC61000-3-2 (Class A) *8				
OTHERS	CASE SIZE/WEIGHT	84 X 46.5 X 180mm [3.31 X 1.83 X 7.09 inches] (W X H X D) / 550g max (with chassis & cover : 880g max)				
	COOLING METHOD	Convection (Refer to "Derating", Instruction Manual 3) *4				

*1 Specification is changed at option, refer to Instruction Manual.

*2 This is the value that measured on measuring board with capacitor of 22μF at 150mm from output terminal.
Measured by 20MHz oscilloscope or Ripple-Noise meter (Equivalent to KEISOKU-GIKEN: RM103).

*3 Drift is the change in DC output for an eight hour period after a half-hour warm-up at 25°C, with the input voltage held constant

at the rated input/output.

*4 Derating is required.

*5 () means peak current. There is a possibility that an internal device is damaged when the specification is exceeded. Please contact us about the detail.

*6 Applicable when remote control (optional) is added.

*7 Please contact us about dynamic load and input response.

*8 Please contact us about another class.

* To meet the specifications. Do not operate over-loaded condition.

* Parallel operation is not possible.

* Derating is required when operated with chassis and cover.

* Sound noise may be generated by power supply in case of pulse load.

Block diagram

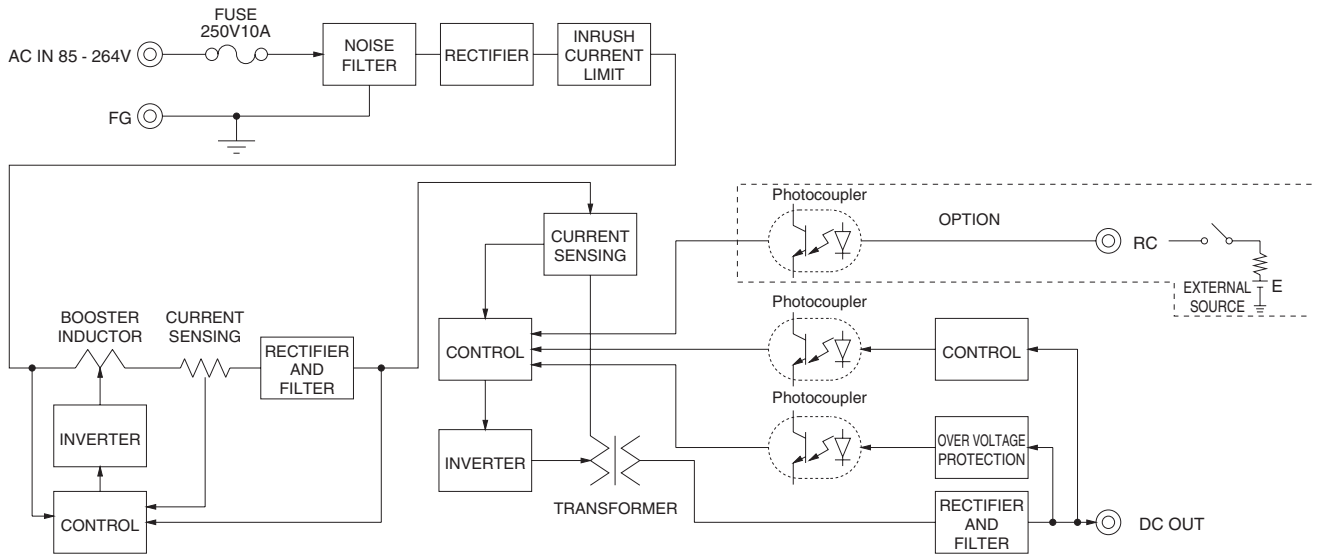

External view

※ External size of option is different from standard model.

Standard type

Chassis and cover type

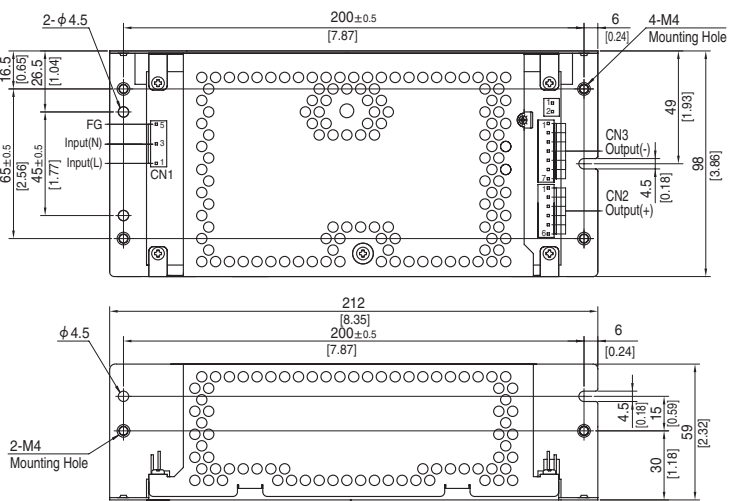
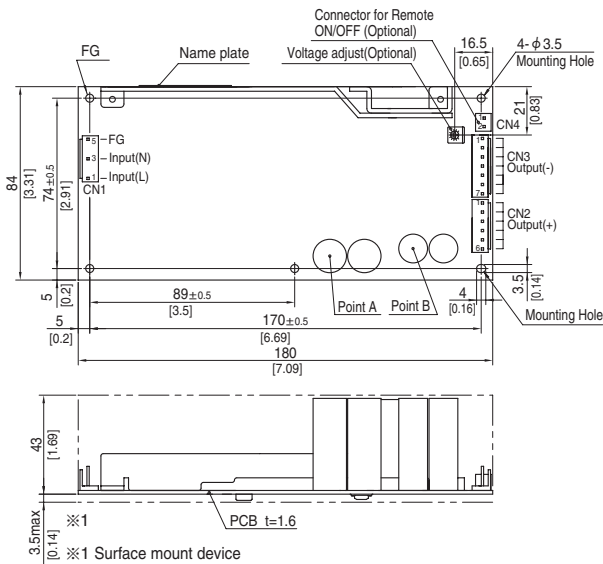

- ※ 5 Mounting holes are existing.
- ※ The back side of P.C.B. of the power supply is assembled some SMDs.
- Be attention not to bump against the attached area by vibration.
- ※ Use the spacer of 8mm length or more regarding insulation.
- And do not use press-fitting bush.
- ※ Point A, Point B are thermometry points. Please refer to Instruction Manual 3.

I/O Connector	Mating connector	Terminal
CN1	1-1123724-3	1123722-5
		Chain 1123721-1
CN2	1-1123723-6	1123722-6
		Chain 1123721-1
CN3	1-1123723-7	1123722-7
		Chain 1123721-1

(Mfr:Tyco Electronics)

- ※ I/O Connector is Mfr. Tyco Electronics
- ※ Option:-J1:VH(J.S.T) connector type.

<PIN CONNECTION>

CN1		CN2		CN3	
Pin No.	Input	Pin No.	Output	Pin No.	Output
1	AC(L)	1 to 6	+V	1 to 7	-V
2					
3	AC(N)				
4					
5	FG				

※ Keep drawing current per pin below 5A for CN2,CN3.

- ※ Tolerance : ±1 [±0.04]
- ※ Weight : 550g max (with chassis & cover : 880g max)
- ※ PCB material : CEM3
- ※ Optional chassis and cover material : Electric galvanizing steel board.
- ※ Dimensions in mm, []=inches
- ※ Mounting torque (Mounting hole of chassis) :1.5N · m (16kgf · cm) max

Connector type

CN4 Option (Mfr:J.S.T)

PIN No.	Contents
1	RC(+)
2	RC(-)

Barrier strip type

Model B2B-XH-A
Mating Connector (Terminal)
XHP-2
(BXH-001T-P0.6
or SXH-001T-P0.6)

LFA300F

LF A 300 F -□ -□
 ① ② ③ ④ ⑤ ⑥

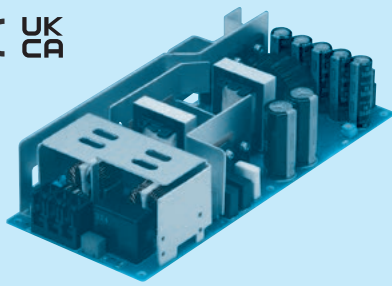
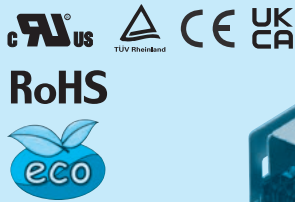

Example recommended EMI/EMC filter
NAC-06-472



High voltage pulse noise type : NAP series
 Low leakage current type : NAM series
 * A higher current rating EMI/EMC filter may be recommended in view of the other devices that could be connected in parallel with the power supply.

- ① Series name
- ② Single output
- ③ Output wattage
- ④ Universal input
- ⑤ Output voltage
- ⑥ Optional *1
- C : with Coating
- G : Low leakage current
- H : with the function to be acceptable to output peak current
 (Only 24V, 30V, 36V and 48V)
- J : EP (Tyco Electronics) connector type
 (Except 3.3V and 5V)
- J1 : VH (J.S.T.) connector type
 (Except 3.3V and 5V)
- R : with Remote ON/OFF
- R2 : with Remote ON/OFF
- S : with Chassis
- SNF : with Chassis & cover & fan
 (Only 5V, 12V and 24V)
- T1 : Horizontal terminal block

This power supply is manufactured by SMD technology. The stress to P.C.B like twisting or bending causes the defect of the unit, so handle the unit with care.

* Make sure necessary tests will be carried out on your end equipment with the power supply installed in accordance with any required EMC/EMI regulations.

Please refer to Instruction manual 6.

MODEL	LFA300F-3R3-TY	LFA300F-5-TY	LFA300F-12-TY	LFA300F-15-TY	LFA300F-24-TY	LFA300F-24-HTY	LFA300F-30-TY	LFA300F-36-TY	LFA300F-48-TY	
MAX OUTPUT WATTAGE[W]	198	300	324	330	336	336 (456)	330	338.4	336	
DC OUTPUT	Convection	3.3V 40A	5V 40A	12V 17A	15V 14A	24V 12.5A	24V 12.5 (19A)	30V 10A	36V 8.4A	48V 6.3A
	Forced air	3.3V 60A	5V 60A	12V 27A	15V 22A	24V 14A	24V 14 (19A)	30V 11A	36V 9.4A	48V 7A

SPECIFICATIONS

	MODEL	LFA300F-3R3-TY	LFA300F-5-TY	LFA300F-12-TY	LFA300F-15-TY	LFA300F-24-TY	LFA300F-24-HTY	LFA300F-30-TY	LFA300F-36-TY	LFA300F-48-TY	
INPUT	VOLTAGE[V]	AC85 - 264 1 φ (Refer to "Derating", Instruction Manual 1 and 3) *4									
	CURRENT[A]	ACIN 100V	2.7typ (Io=100%)	4.1typ (Io=100%)							
		ACIN 200V	1.4typ (Io=100%)	2.0typ (Io=100%)							
	FREQUENCY[Hz]	50 / 60 (47 - 63)									
	EFFICIENCY[%]	ACIN 100V	75.0typ	79.0typ	80.0typ	81.5typ	85.0typ	85.0typ	85.5typ	85.5typ	85.5typ
		ACIN 200V	77.0typ	82.5typ	83.0typ	84.5typ	88.0typ	88.0typ	88.0typ	88.0typ	88.0typ
	POWER FACTOR (Io=100%)	ACIN 100V	0.98typ	0.99typ							
		ACIN 200V	0.92typ	0.95typ							
	INRUSH CURRENT[A]	ACIN 100V	15 / 30typ (Io=100%) (Primary inrush current /Secondary inrush current) (More than 3 sec. to re-start)								
		ACIN 200V	30 / 30typ (Io=100%) (Primary inrush current /Secondary inrush current) (More than 3 sec. to re-start)								
LEAKAGE CURRENT[ma]	0.45 / 0.75max (ACIN 100V / 240V 60Hz, Io=100%, According to IEC62368-1 and DEN-AN)										
OUTPUT	VOLTAGE[V]	3.3	5	12	15	24	24	30	36	48	
	CURRENT[A]	Convection	40	40	17	14	12.5	12.5 (Peak19)	10	8.4	6.3
		Forced air	60	60	27	22	14	14 (Peak19)	11	9.4	7
	LINE REGULATION[mV]	20max	20max	48max	60max	96max	96max	144max	144max	192max	
	LOAD REGULATION[mV]	40max	40max	100max	120max	150max	150max	240max	240max	240max	
	RIPPLE[mVp-p]	0 to +40°C *2	80max	80max	120max	120max	120max	240max	150max	150max	150max
		-10 - 0°C *2	140max	140max	160max	160max	160max	320max	200max	200max	200max
	RIPPLE NOISE[mVp-p]	0 to +40°C *2	120max	120max	150max	150max	150max	300max	250max	250max	250max
		-10 - 0°C *2	160max	160max	180max	180max	180max	360max	300max	300max	300max
	TEMPERATURE REGULATION[mV]	0 to +40°C	50max	50max	120max	150max	240max	240max	360max	360max	480max
		-10 to +40°C	60max	60max	150max	180max	290max	290max	450max	450max	600max
	DRIFT[mV]	20max	20max	48max	60max	96max	96max	144max	144max	192max	
	START-UP TIME[ms]	350typ (ACIN 100V, Io=100%)									
HOLD-UP TIME[ms]	20typ (ACIN 100V, Io=100%)										
OUTPUT VOLTAGE ADJUSTMENT RANGE[V]	2.85 to 3.63	4.50 to 5.50	10.80 to 13.20	13.50 to 16.50	21.60 to 27.50	21.60 to 27.50	27.00 to 33.00	32.40 to 39.60	39.60 to 52.80		
OUTPUT VOLTAGE SETTING[V]	3.30 to 3.40	5.00 to 5.15	12.00 to 12.48	15.00 to 15.60	24.00 to 24.96	24.00 to 24.96	30.00 to 31.20	36.00 to 37.44	48.00 to 49.92		
PROTECTION CIRCUIT AND OTHERS	OVERCURRENT PROTECTION	Works over 105% of rating (works over 101% of peak current at option -H) and recovers automatically									
	OVERVOLTAGE PROTECTION	4.00 to 5.25	5.75 to 7.00	13.80 to 16.80	17.25 to 21.00	27.60 to 33.60	27.60 to 33.60	34.50 to 42.00	41.40 to 50.40	55.20 to 67.20	
	OPERATING INDICATION	Not provided									
	REMOTE SENSING	Not provided									
	REMOTE ON/OFF	Option (Refer to Instruction Manual)									
ISOLATION	INPUT-OUTPUT-RC	*6 AC3,000V 1minute, Cutoff current = 10mA, DC500V 50MΩ min (At Room Temperature)									
	INPUT-FG	AC2,000V 1minute, Cutoff current = 10mA, DC500V 50MΩ min (At Room Temperature)									
	OUTPUT-RC-FG	*6 AC500V 1minute, Cutoff current = 25mA, DC500V 50MΩ min (At Room Temperature)									
	OUTPUT-RC	*6 AC100V 1minute, Cutoff current = 25mA, DC100V 10MΩ min (At Room Temperature)									
ENVIRONMENT	OPERATING TEMP., HUMID. AND ALTITUDE *4	-10 to +70°C, 20 - 90%RH (Non condensing) (Refer to "Derating", Instruction Manual 3), 3,000m (10,000feet) max									
	STORAGE TEMP., HUMID. AND ALTITUDE	-20 to +75°C, 20 - 90%RH (Non condensing), 9,000m (30,000feet) max									
	VIBRATION	10 - 55Hz, 19.6m/s ² (2G), 3minutes period, 60minutes each along X, Y and Z axis									
	IMPACT	196.1m/s ² (20G), 11ms, once each X, Y and Z axis									
SAFETY AND NOISE REGULATIONS	AGENCY APPROVALS	UL60950-1, C-UL (CSA60950-1), EN62368-1 Complies with DEN-AN									
	CONDUCTED NOISE	Complies with FCC-B, VCCI-B, CISPR-B, EN55011-B, EN55022-B									
	HARMONIC ATTENUATOR	Complies with IEC61000-3-2 (Class A) *8									
OTHERS	CASE SIZE/WEIGHT	95X52.5X222mm [3.74X2.07X8.74 inches] (W X H X D) (without terminal block) / 810g max (with chassis & cover : 1,270g max)									
	COOLING METHOD	Convection / Forced air (Refer to "Derating", Instruction Manual 3) *4									

*1 Specification is changed at option, refer to Instruction Manual.
 *2 This is the value that measured on measuring board with capacitor of 22 μF at 150mm from output terminal.
 *3 Drift is the change in DC output for an eight hour period after a half-hour warm-up at 25°C, with the input voltage held constant
 *4 Derating is required.
 *5 () means peak current. There is a possibility that an internal device is damaged when the specification is exceeded. Please contact us about the detail.
 *6 Applicable when remote control (optional) is added.
 *7 Please contact us about dynamic load and input response.
 *8 Please contact us about another class.
 *9 To meet the specifications. Do not operate over-loaded condition.
 *10 Parallel operation is not possible.
 *11 Derating is required when operated with chassis and cover.
 *12 Sound noise may be generated by power supply in case of pulse load.

Block diagram

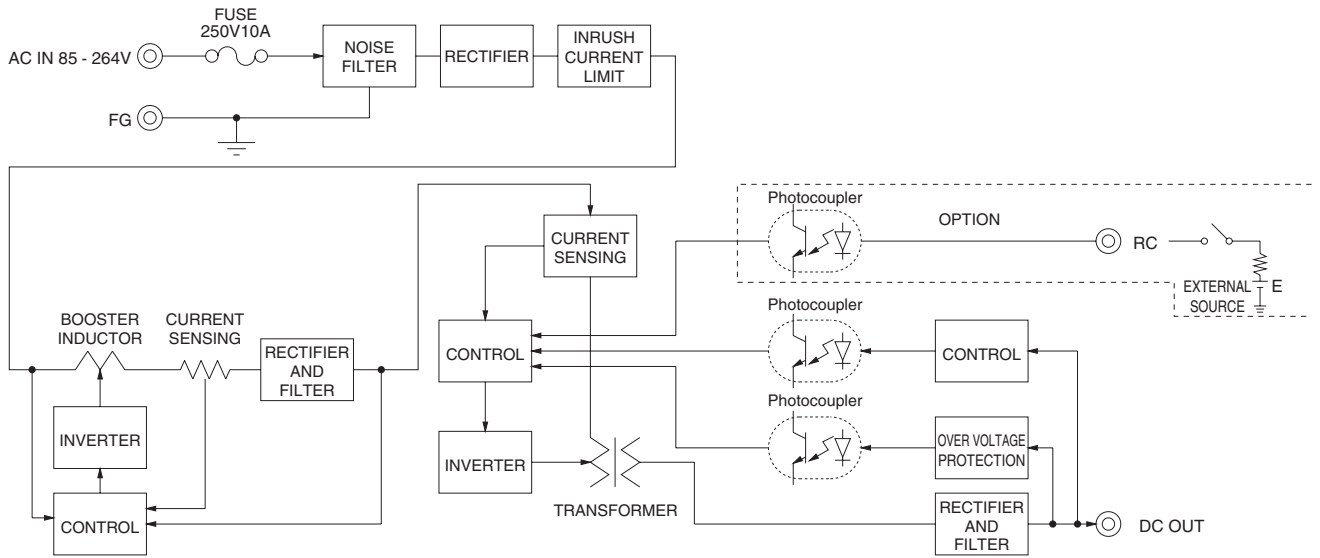

External view

※ External size of option is different from standard model.

Standard type

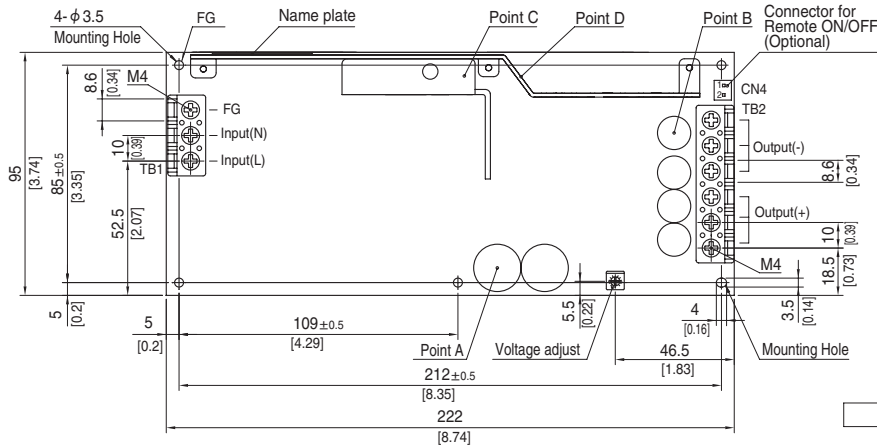

Connector type

CN4 Option (Mfr.:J.S.T)

PIN No.	Contents
1	RC(+)
2	RC(-)

Barrier strip type

Model B2B-XH-A
Mating Connector (Terminal)
XHP-2
(BXH-001T-P0.6
or SXH-001T-P0.6)

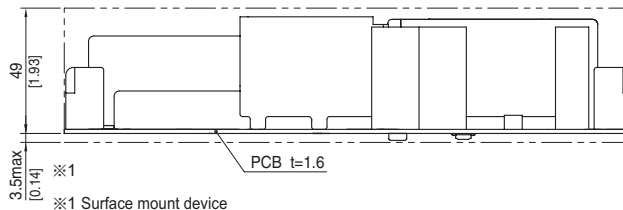

- ※ 5 Mounting holes are existing.
- ※ The back side of P.C.B. of the power supply is assembled some SMDs.
- Be attention not to bump against the attached area by vibration.
- ※ Use the spacer of 8mm length or more regarding insulation. And do not use press-fitting bush.
- ※ Point A, Point B, Point C, Point D are thermometry points. Please refer to Instruction Manual 3.
- ※ Keep drawing current per pin below 20A for TB2.

- ※ Tolerance : ± 1 [± 0.04]
- ※ Weight : 810g max (with chassis & cover : 1,270g max)
- ※ PCB material : CEM3
- ※ Dimensions in mm, []=inches
- ※ Screw tightening torque : M4 1.6N · m (16.9kgf · cm) max

Assembling and Installation Method

Installation method

■ This power supply is manufactured by SMD technology. The stress to P.C.B like twisting or bending causes the defect of the unit, so handle the unit with care.

■ In case of metal chassis, keep the distance between d1 & d2 for to insulate between lead of component and metal chassis, use the spacer of 8mm or more between d1. If it is less than d1 & d2, insert the insulation sheet between power supply and metal chassis.

■ There is a possibility that it is not possible to cool enough when the power supply is used by the sealing up space as showing in right figure. Please use it after confirming the temperature of point A and point B of Instruction Manual 3.

■ (F) mounting is not possible when unit is with case cover, but if need to operate unit by (F) positioning with case cover, temperature / load derating is necessary. For more details, please contact our sales or engineering departments.

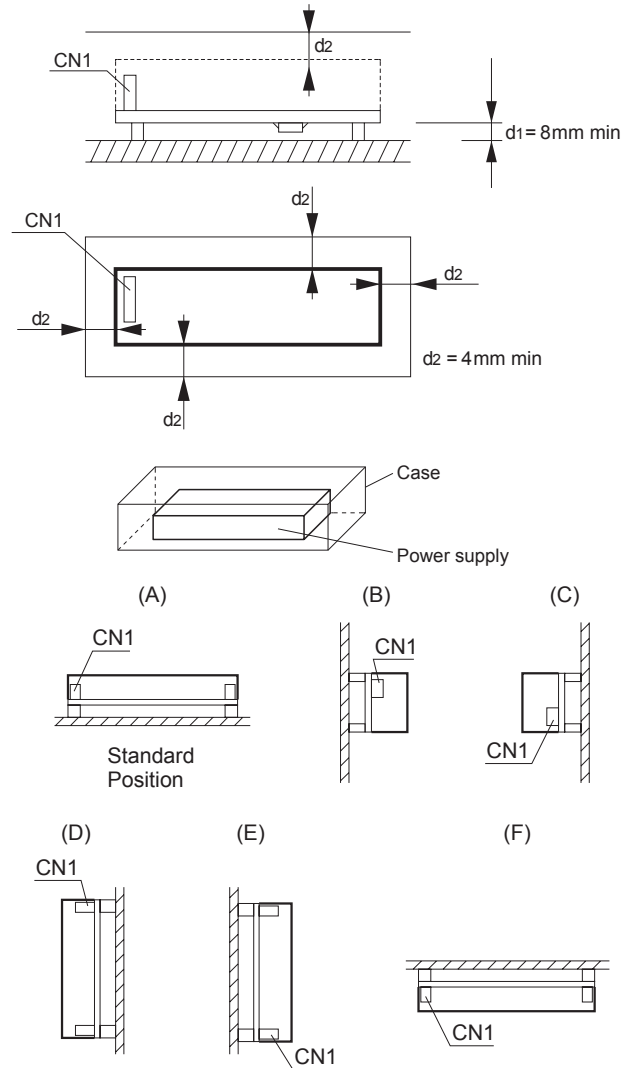

Mounting screw

■ The mounting screw should be M3. The hatched area shows the allowance of metal parts for mounting.

● LFA10F, LFA15F

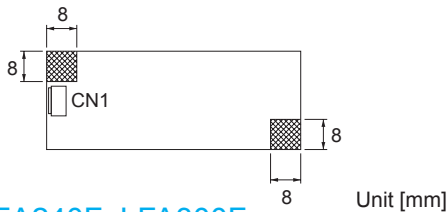

● LFA30F, LFA50F, LFA75F, LFA100F, LFA150F

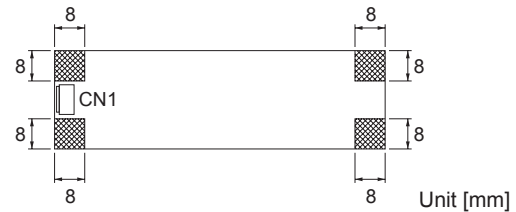

● LFA240F, LFA300F

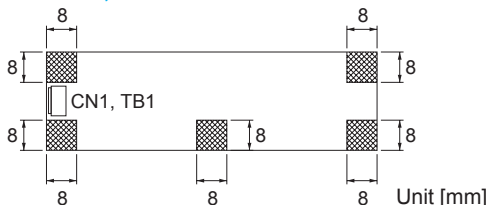

■ If metallic fittings are used on the component side of the board, ensure there is no contact with surface mounted components.

■ This product uses SMD technology. Please avoid the PCB installation method which includes the twisting stress or the bending stress.

*Recommendation to electrically connect FG to metal chassis for reducing noise.

Derating

● Derating curve for input voltage

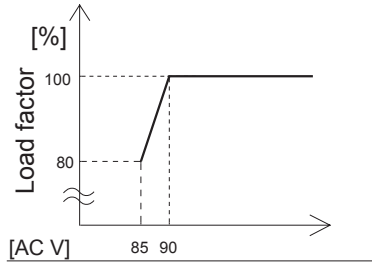

● LFA10F Ambient temperature derating curve (Reference value)

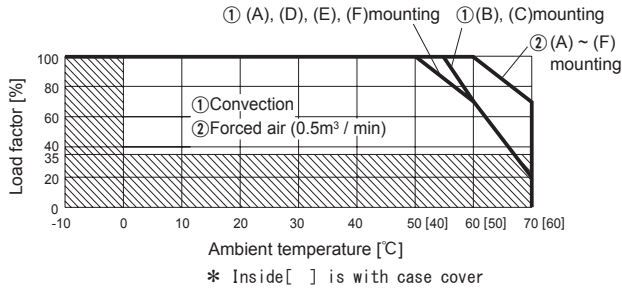

● LFA15F Ambient temperature derating curve (Reference value)

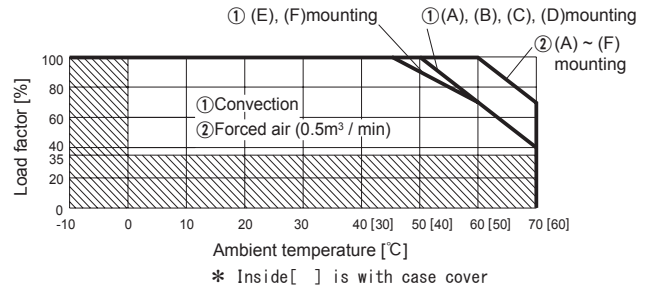

● LFA30F Ambient temperature derating curve (Reference value)

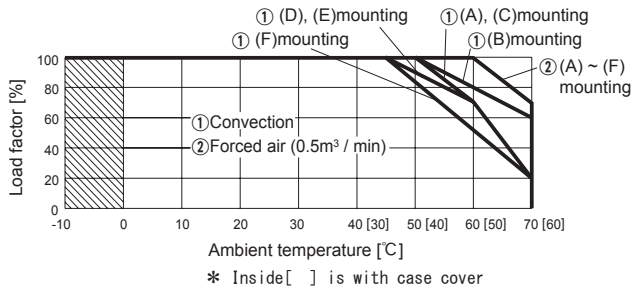

● LFA50F Ambient temperature derating curve (Reference value)

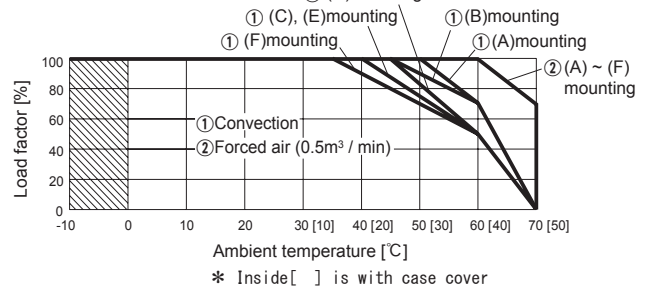

● LFA75F Ambient temperature derating curve (Reference value)

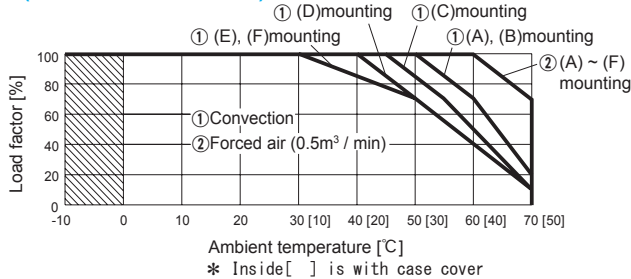

● LFA100F Ambient temperature derating curve (Reference value)

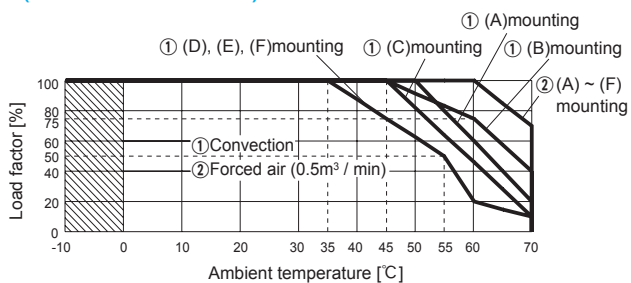

● LFA100F-□-SN Ambient temperature derating curve (Reference value)

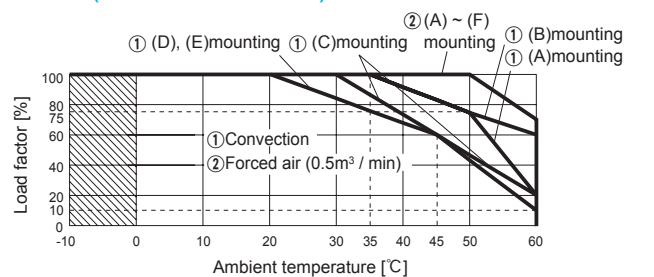

Derating

● LFA150F Ambient temperature derating curve (Reference value)

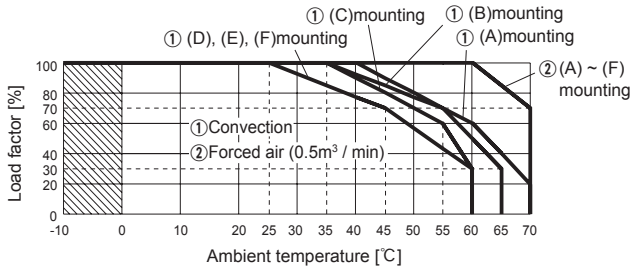

● LFA150F-□-SN Ambient temperature derating curve (Reference value)

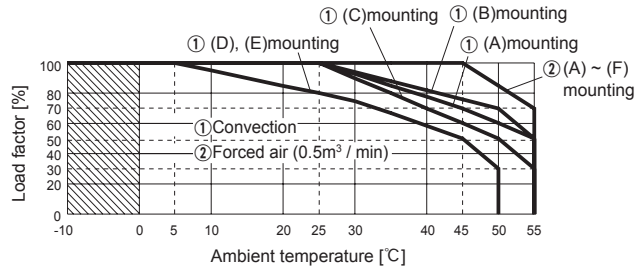

● LFA240F Ambient temperature derating curve (Reference value)

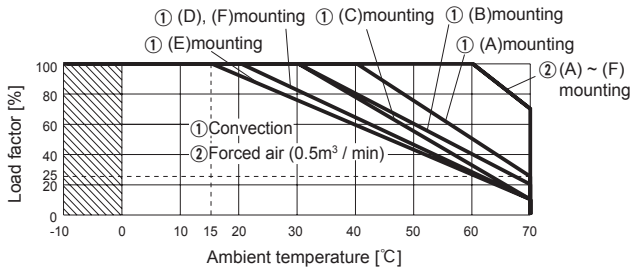

● LFA240F-□-SN Ambient temperature derating curve (Reference value)

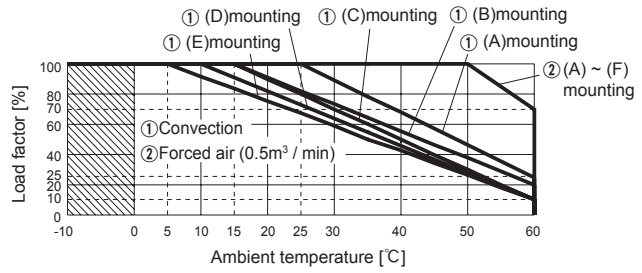

● LFA300F Ambient temperature derating curve (Reference value)

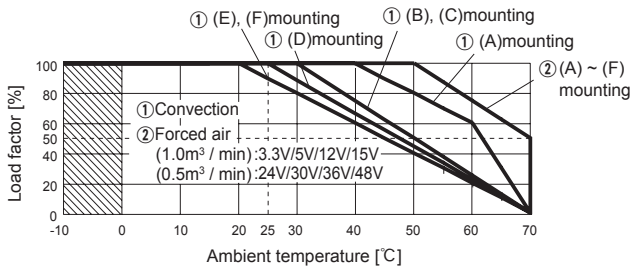

Output voltage	Output power[W]	
	①Convection	②Forced air
3.3V	132.0	198.0
5V	200.0	300.0
12V	204.0	324.0
15V	210.0	330.0
24V	300.0	336.0
30V	300.0	330.0
36V	302.4	338.4
48V	302.4	336.0

- The operative ambient temperature is different by with / without chassis cover or mounting position.
Note: In the hatched area, the specification of Ripple, Ripple Noise is different from other area.
- Make sure the temperature at point A and point B is less than the temperatures shown in Instruction Manual 3.
- The ambient temperature should be measured 5 to 10 cm away from the power supply so that it won't be influenced by the heat from the power supply. Please consult us for more details.

Instruction Manual

◆ It is necessary to read the "Instruction Manual" and "Before using our product" before you use our product.

LFA

NOTICE



Instruction Manual

<https://www.cosel.co.jp/redirect/catalog/en/LFA/>

Before using our product

<https://en.cosel.co.jp/technical/caution/index.html>

Basic Characteristics Data

Model	Circuit method	Switching frequency [kHz]	Input current *1 [A]	Inrush current protection	PCB/Pattern			Series/Parallel operation availability *2	
					Material	Single sided	Double sided	Series operation	Parallel operation
LFA10F	Flyback converter	100	0.26	LF	CEM-3	Yes		Yes	No
LFA15F	Flyback converter	100	0.35	Thermistor	CEM-3	Yes		Yes	No
LFA30F	Flyback converter	130	0.65	Thermistor	CEM-3	Yes		Yes	No
LFA50F	Active filter	60-440	0.67	Thermistor	CEM-3	Yes		Yes	No
	Flyback converter	130							
LFA75F	Active filter	60-440	1.0	Thermistor	CEM-3	Yes		Yes	No
	Flyback converter	130							
LFA100F	Active filter	60	1.3	Thermistor	CEM-3		Yes	Yes	No
	Forward converter	140							
LFA150F	Active filter	60	2.0	Thermistor	CEM-3		Yes	Yes	No
	Forward converter	140							
LFA240F	Active filter	60	3.3	SCR	CEM-3		Yes	Yes	No
	Forward converter	140							
LFA300F	Active filter	60	4.1	SCR	CEM-3		Yes	Yes	No
	Forward converter	140							

*1 The value of input current is at ACIN 100V and rated load.

*2 Refer to Instruction Manual 2.

LFA

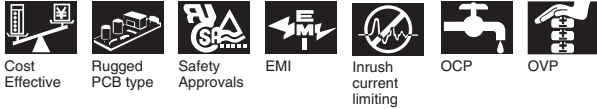

LGA-series

LGA

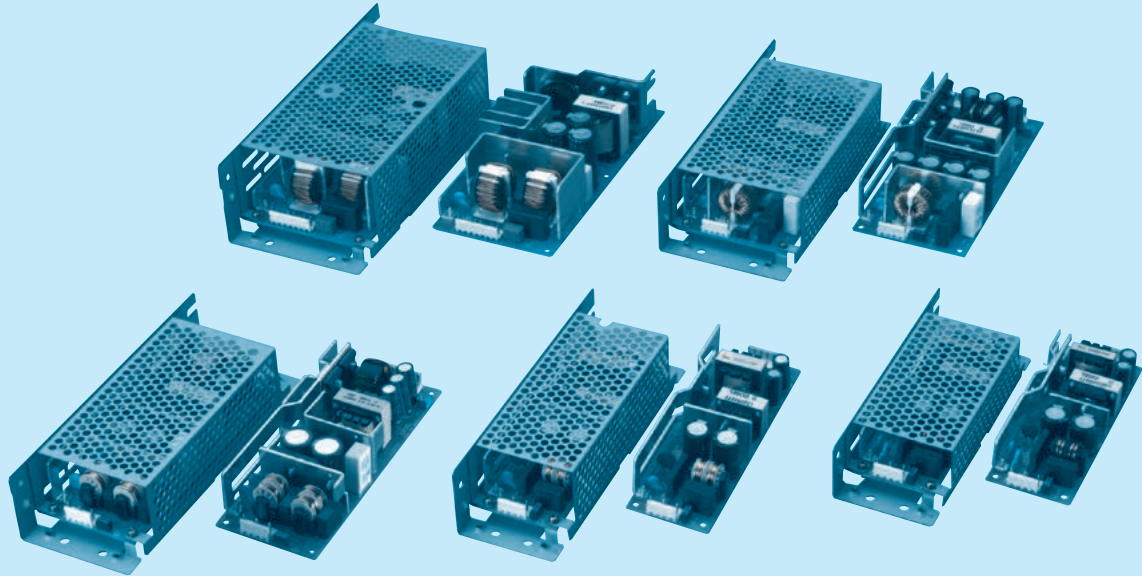

■ Feature

Small and compact PCB construction
Built-in inrush current, overcurrent and overvoltage protection circuits

■ Safety agency approvals

UL60950-1, C-UL(CSA60950-1) recognized, EN62368-1 approved
Complies with DEN-AN

■ EMI

Complies with FCC-B, CISPR22-B, EN55011-B, EN55022-B, VCCI-B

■ 5-year warranty (refer to Instruction Manual)

■ CE marking

Low Voltage Directive
RoHS Directive

■ UKCA marking

Electrical Equipment Safety Regulations
RoHS Regulations

■ EMS Compliance : EN61204-3, EN61000-6-2

EN61000-4-2
EN61000-4-3
EN61000-4-4
EN61000-4-5
EN61000-4-6
EN61000-4-8
EN61000-4-11

LGA50A

LG A 50 A -5 -□

① ② ③ ④ ⑤ ⑥

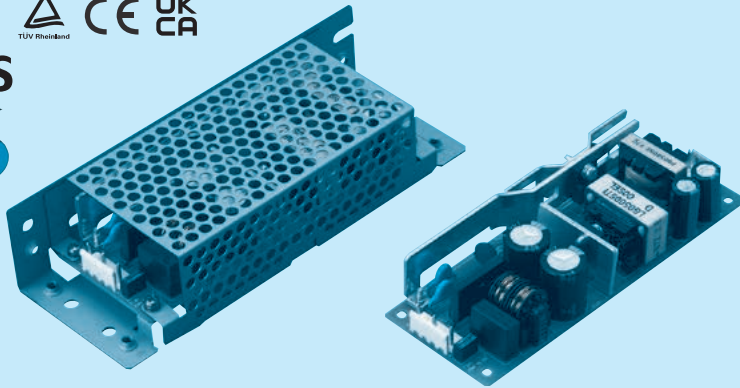

Example recommended EMI/EMC filter
NAC-06-472



High voltage pulse noise type : NAP series
Low leakage current type : NAM series
* A higher current rating EMI/EMC filter may be recommended in view of the other devices that could be connected in parallel with the power supply.

- ① Series name
- ② Single output
- ③ Output wattage
- ④ 100/120V input
- ⑤ Output voltage
- ⑥ Optional
- C :with Coating
- G :Low leakage current
- H :with the function to be acceptable to output peak current (only 24V)
- J1 :VH(J.S.T.)connector type
- S :with Chassis
- SN:with Chassis & cover
- Y :with Potentiometer

This power supply is manufactured by SMD technology. The stress to P.C.B like twisting or bending causes the defect of the unit, so handle the unit with care.
*Make sure necessary tests will be carried out on your end equipment with the power supply installed in accordance with any required EMC/EMI regulations.

MODEL	LGA50A-3R3-Y	LGA50A-5	LGA50A-12	LGA50A-15	LGA50A-24	LGA50A-24-H	LGA50A-48
MAX OUTPUT WATTAGE[W]	33	50	51.6	52.5	60	60	62.4
DC OUTPUT	3.3V 10A	5V 10A	12V 4.3A	15V 3.5A	24V 2.5A	24V 2.5 (Peak 3.2) A	48V 1.3A

SPECIFICATIONS

MODEL	LGA50A-3R3-Y	LGA50A-5	LGA50A-12	LGA50A-15	LGA50A-24	LGA50A-24-H	LGA50A-48
INPUT	VOLTAGE[V] AC85 - 132 1 φ (Refer to "Derating", Instruction Manual 1 and 3) CURRENT[A] ACIN 100V 0.8typ (Io=100%) 1.3typ (Io=100%) FREQUENCY[Hz] 47 - 440 (Refer to Instruction Manual 1.1) EFFICIENCY[%] ACIN 100V 74.0typ (Io=100%) 79.0typ (Io=100%) 82.0typ (Io=100%) 83.0typ (Io=100%) 85.0typ (Io=100%) 85.0typ (Io=100%) 85.0typ (Io=100%) INRUSH CURRENT[A] ACIN 100V 30typ (Io=100%), (At cold start), (Ta= 25°C) LEAKAGE CURRENT[ma] 0.5max (ACIN 100V, 60Hz, Io=100%, According to IEC62368-1 and DEN-AN)						
OUTPUT	VOLTAGE[V] 3.3 CURRENT[A] *3 10.0 LINE REGULATION[mV] 20max LOAD REGULATION[mV] 40max RIPPLE[mVp-p] 0 to +50°C *1 80max -10 - 0°C *1 140max RIPPLE NOISE[mVp-p] 0 to +50°C *1 120max -10 - 0°C *1 160max TEMPERATURE REGULATION[mV] 0 to +50°C *4 50max -10 to +50°C *4 60max DRIFT[mV] *2 20max START-UP TIME[ms] 200max (ACIN 100V, Io=100%) HOLD-UP TIME[ms] 20typ (ACIN 100V, Io=100%) OUTPUT VOLTAGE ADJUSTMENT RANGE[V] 2.85 - 3.63 Fixed ("Y" which can be adjusted the output is available as optional ± 10%) OUTPUT VOLTAGE SETTING[V] 3.30 - 3.40 4.90 - 5.30 11.50 - 12.50 14.40 - 15.60 23.00 - 25.00 23.00 - 25.00 46.00 - 50.00	5	12	15	24	24 (Peak 3.2)	48
PROTECTION CIRCUIT AND OTHERS	OVERCURRENT PROTECTION Works over 105% of rating (works over 101% of peak current at option -H) and recovers automatically OVERVOLTAGE PROTECTION 4.00 - 5.25 5.75 - 7.00 13.80 - 16.80 17.30 - 21.00 27.60 - 35.00 27.60 - 35.00 55.20 - 67.20 OPERATING INDICATION Not provided REMOTE SENSING Not provided REMOTE ON/OFF Not provided						
ISOLATION	INPUT-OUTPUT AC2,000V 1minute, Cutoff current = 10mA, DC500V 50MΩ min (At Room Temperature) INPUT-FG AC2,000V 1minute, Cutoff current = 10mA, DC500V 50MΩ min (At Room Temperature) OUTPUT-FG AC500V 1minute, Cutoff current = 25mA, DC500V 50MΩ min (At Room Temperature)						
ENVIRONMENT	OPERATING TEMP., HUMID. AND ALTITUDE -10 to +60°C, 20 - 90%RH (Non condensing) (Refer to "Derating", Instruction Manual 3), 3,000m (10,000feet) max STORAGE TEMP., HUMID. AND ALTITUDE -20 to +75°C, 20 - 90%RH (Non condensing), 9,000m (30,000feet) max VIBRATION 10 - 55Hz, 19.6m/s ² (2G), 3minutes period, 60minutes each along X, Y and Z axis IMPACT 196.1m/s ² (20G), 11ms, once each X, Y and Z axis						
SAFETY AND NOISE REGULATIONS	AGENCY APPROVALS UL60950-1, C-UL (CSA60950-1), EN62368-1 Complies with DEN-AN CONDUCTED NOISE Complies with FCC-B, VCCI-B, CISPR-B, EN55011-B, EN55022-B						
OTHERS	CASE SIZE/WEIGHT 50 X 28.5 X 132mm [1.97 X 1.12 X 5.2 inches] (W X H X D) / 160g max (with chassis & cover : 320g max) COOLING METHOD Convection (Refer to "Derating", Instruction Manual 3)						

*1 This is the value that measured on measuring board with capacitor of 22 μF at 150mm from output terminal.
Measured by 20MHz oscilloscope or Ripple-Noise meter (Equivalent to KEISOKU-GIKEN: RM-103).
*2 Drift is the change in DC output for an eight hour period after a half-hour warm-up at 25°C, with the input voltage held constant at the rated input/output.
*3 Peak loading for 10sec. And Duty 35% max. or less is acceptable if the total wattage is less than the rated wattage (24V:60W).
Refer to instruction Manual 6. In detail.

*4 Only output 24V and 48V DC models are applied that the upper temperature limit is 45°C.
* Avoid prolonged use under over - load.
* Parallel operation with other model is not possible.
* Derating is required when operated with chassis and cover.
* A sound may occur from power supply at pulse loading.

Block diagram

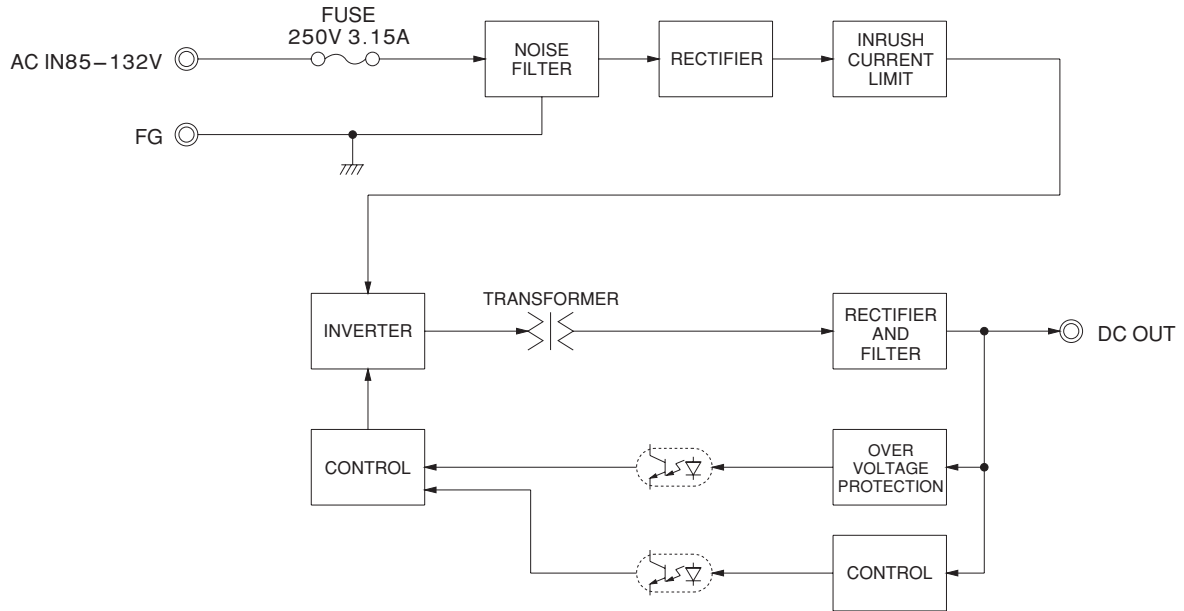

LGA

External view

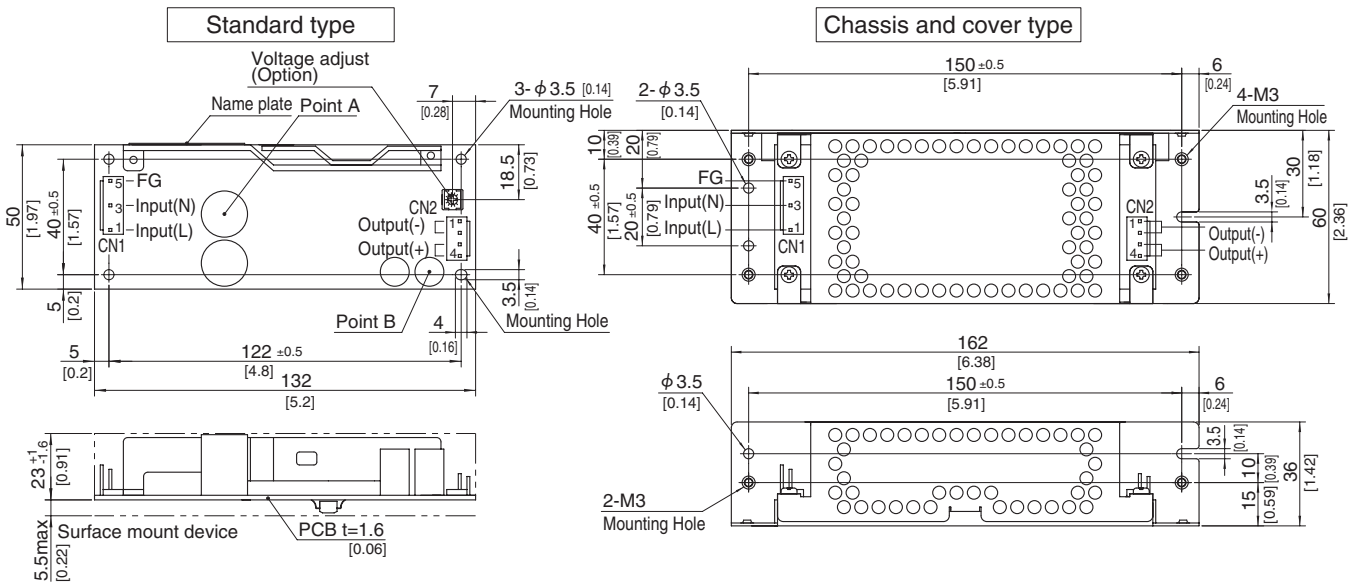

- ※ This power supply is manufactured by SMD technology. The stress to P.C.B like twisting or bending causes the defect of the unit, so handle the unit with care. Take care for SMD parts on the back to come in contact because of the vibration and not to break down.
- ※ Use the spacer of 8mm length or more.
- ※ 4 Mounting holes are existing.

※Mounting torque:0.6N.m(6.3kgf.cm)max

I/O Connector	Mating connector	Terminal
CN1	1-1123724-3	Chain 1123721-1
		Loose 1318912-1
CN2	1-1123723-4	Chain 1123721-1
		Loose 1318912-1

(Mfr:Tyco Electronics AMP)

※I/O Connector is Mfr Tyco Electronics AMP
 ※Option:-J1:VH(J.S.T) connector type.
 Refer to instruction Manual 6.

<PIN CONNECTION>

CN1		CN2	
Pin No.	Input	Pin No.	Output
1	AC(L)	1, 2	-V
2			
3	AC(N)	3, 4	+V
4			
5	FG		

※Keep drawing current per pin below 5A for CN2.

- ※Tolerance : ±1 [±0.04]
- ※Weight : 160g max (with chassis & cover : 320g max)
- ※PCB material / thickness : CEM3 / 1.6mm [0.06]
- ※Optional chassis and cover material : Electric galvanizing steel board.
- ※Dimensions in mm, []=inches

LGA75A

LG A 75 A -5 -□
 ① ② ③ ④ ⑤ ⑥

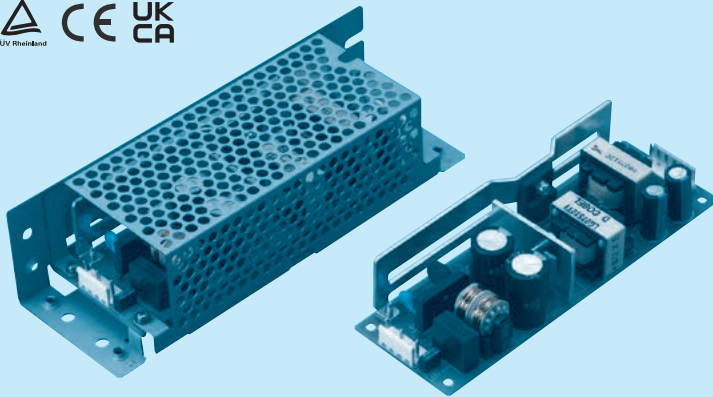
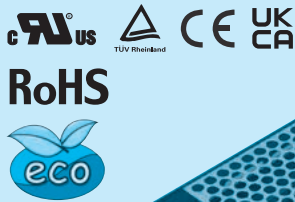

Example recommended EMI/EMC filter
NAC-06-472



High voltage pulse noise type : NAP series
 Low leakage current type : NAM series
 * A higher current rating EMI/EMC filter may be recommended in view of the other devices that could be connected in parallel with the power supply.

- ① Series name
- ② Single output
- ③ Output wattage
- ④ 100/120V input
- ⑤ Output voltage
- ⑥ Optional
- C :with Coating
- G :Low leakage current
- H :with the function to be acceptable to output peak current (only 24V)
- J1 :VH(J.S.T.)connector type
- S :with Chassis
- SN:with Chassis & cover
- Y :with Potentiometer

This power supply is manufactured by SMD technology. The stress to P.C.B like twisting or bending causes the defect of the unit, so handle the unit with care.
 *Make sure necessary tests will be carried out on your end equipment with the power supply installed in accordance with any required EMC/EMI regulations.

MODEL	LGA75A-3R3-Y	LGA75A-5	LGA75A-12	LGA75A-15	LGA75A-24	LGA75A-24-H	LGA75A-48
MAX OUTPUT WATTAGE[W]	49.5	75	75.6	75	76.8	76.8	76.8
DC OUTPUT	3.3V 15A	5V 15A	12V 6.3A	15V 5A	24V 3.2A	24V 3.2 (Peak 4.2) A	48V 1.6A

SPECIFICATIONS

MODEL	LGA75A-3R3-Y	LGA75A-5	LGA75A-12	LGA75A-15	LGA75A-24	LGA75A-24-H	LGA75A-48									
INPUT	VOLTAGE[V]															
	AC85 - 132 1 φ (Refer to "Derating", Instruction Manual 1 and 3)															
	CURRENT[A]		ACIN 100V													
			1.3typ (Io=100%)		1.7typ (Io=100%)											
	FREQUENCY[Hz]															
	47 - 440 (Refer to Instruction Manual 1.1)															
OUTPUT	EFFICIENCY[%]		ACIN 100V													
			75.0typ (Io=100%)		79.0typ (Io=100%)		83.0typ (Io=100%)		84.0typ (Io=100%)		86.0typ (Io=100%)		86.0typ (Io=100%)		86.0typ (Io=100%)	
	INRUSH CURRENT[A]		ACIN 100V		30typ (Io=100%), (At cold start), (Ta= 25°C)											
	LEAKAGE CURRENT[ma]															
	0.5max (ACIN 100V, 60Hz, Io=100%, According to IEC62368-1 and DEN-AN)															
	VOLTAGE[V]		3.3		5		12		15		24		24		48	
	CURRENT[A]		*3		15.0		15.0		6.3		5.0		3.2		3.2 (Peak 4.2)	
	LINE REGULATION[mV]		20max		20max		48max		60max		96max		96max		192max	
	LOAD REGULATION[mV]		40max		40max		100max		120max		150max		150max		300max	
	RIPPLE[mVp-p]		0 to +50°C *1		80max		80max		120max		120max		120max		240max	
			-10 - 0°C *1		140max		140max		160max		160max		160max		320max	
	RIPPLE NOISE[mVp-p]		0 to +50°C *1		120max		120max		150max		150max		150max		300max	
		-10 - 0°C *1		160max		160max		180max		180max		180max		360max		
TEMPERATURE REGULATION[mV]		0 to +50°C		50max		50max		120max		150max		240max		240max		
		-10 to +50°C		60max		60max		150max		180max		290max		290max		
DRIFT[mV]		*2		20max		20max		48max		60max		96max		96max		
START-UP TIME[ms]		200max (ACIN 100V, Io=100%)														
HOLD-UP TIME[ms]		20typ (ACIN 100V, Io=100%)														
OUTPUT VOLTAGE ADJUSTMENT RANGE[V]		2.85 - 3.63		Fixed ("Y" which can be adjusted the output is available as optional ± 10%)												
OUTPUT VOLTAGE SETTING[V]		3.30 - 3.40		4.90 - 5.30		11.50 - 12.50		14.40 - 15.60		23.00 - 25.00		23.00 - 25.00		46.00 - 50.00		
PROTECTION CIRCUIT AND OTHERS	OVERCURRENT PROTECTION															
	Works over 105% of rating (works over 101% of peak current at option -H) and recovers automatically															
	OVERVOLTAGE PROTECTION															
	4.00 - 5.25 5.75 - 7.00 13.80 - 16.80 17.30 - 21.00 27.60 - 35.00 27.60 - 35.00 55.20 - 67.20															
OPERATING INDICATION																
Not provided																
REMOTE SENSING																
Not provided																
REMOTE ON/OFF																
Not provided																
ISOLATION	INPUT-OUTPUT															
	AC2,000V 1minute, Cutoff current = 10mA, DC500V 50MΩ min (At Room Temperature)															
	INPUT-FG															
AC2,000V 1minute, Cutoff current = 10mA, DC500V 50MΩ min (At Room Temperature)																
OUTPUT-FG																
AC500V 1minute, Cutoff current = 25mA, DC500V 50MΩ min (At Room Temperature)																
ENVIRONMENT	OPERATING TEMP., HUMID. AND ALTITUDE															
	-10 to +60°C, 20 - 90%RH (Non condensing) (Refer to "Derating", Instruction Manual 3), 3,000m (10,000feet) max															
	STORAGE TEMP., HUMID. AND ALTITUDE															
	-20 to +75°C, 20 - 90%RH (Non condensing), 9,000m (30,000feet) max															
VIBRATION																
10 - 55Hz, 19.6m/s ² (2G), 3minutes period, 60minutes each along X, Y and Z axis																
IMPACT																
196.1m/s ² (20G), 11ms, once each X, Y and Z axis																
SAFETY AND NOISE REGULATIONS	AGENCY APPROVALS															
	UL60950-1, C-UL (CSA60950-1), EN62368-1 Complies with DEN-AN															
CONDUCTED NOISE																
Complies with FCC-B, VCCI-B, CISPR-B, EN55011-B, EN55022-B																
OTHERS	CASE SIZE/WEIGHT															
	50 X 34.5 X 150mm [1.97 X 1.36 X 5.91 inches] (W X H X D) / 200g max (with chassis & cover : 410g max)															
COOLING METHOD																
Convection (Refer to "Derating", Instruction Manual 3)																

*1 This is the value that measured on measuring board with capacitor of 22 μF at 150mm from output terminal.
 Measured by 20MHz oscilloscope or Ripple-Noise meter (Equivalent to KEISOKU-GIKEN: RM-103).
 *2 Drift is the change in DC output for an eight hour period after a half-hour warm-up at 25°C, with the input voltage held constant at the rated input/output.
 *3 Peak loading for 10sec. And Duty 35% max. or less is acceptable if the total wattage is less than the rated wattage.
 Refer to instruction Manual 6. In detail.
 * Avoid prolonged use under over - load.
 * Parallel operation with other model is not possible.
 * Derating is required when operated with chassis and cover.
 * A sound may occur from power supply at pulse loading.

Block diagram

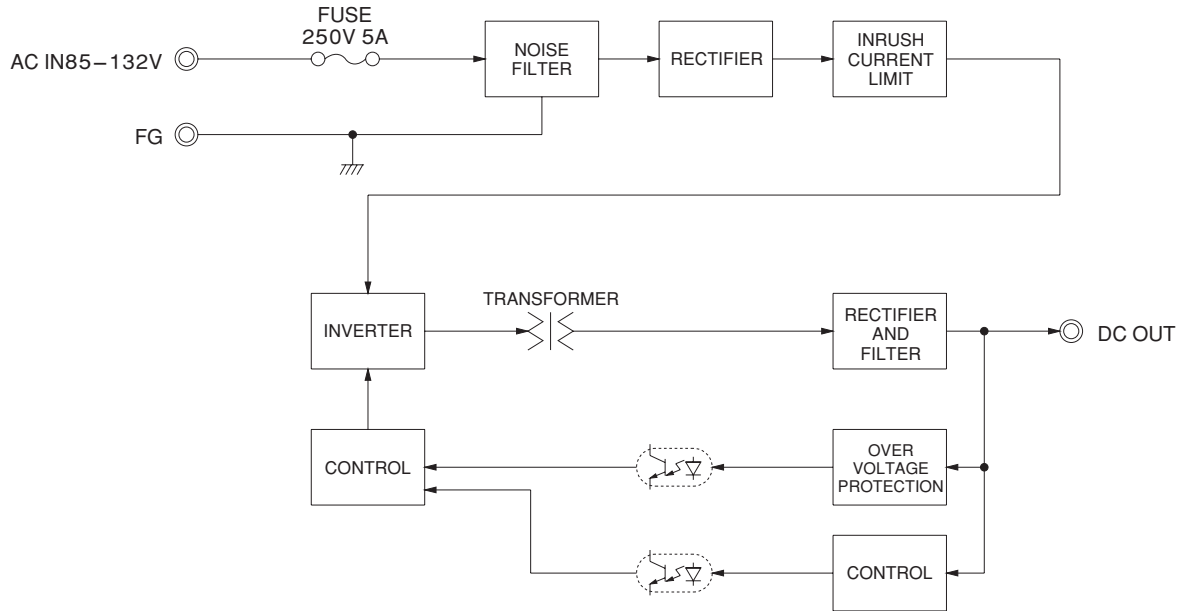

LGA

External view

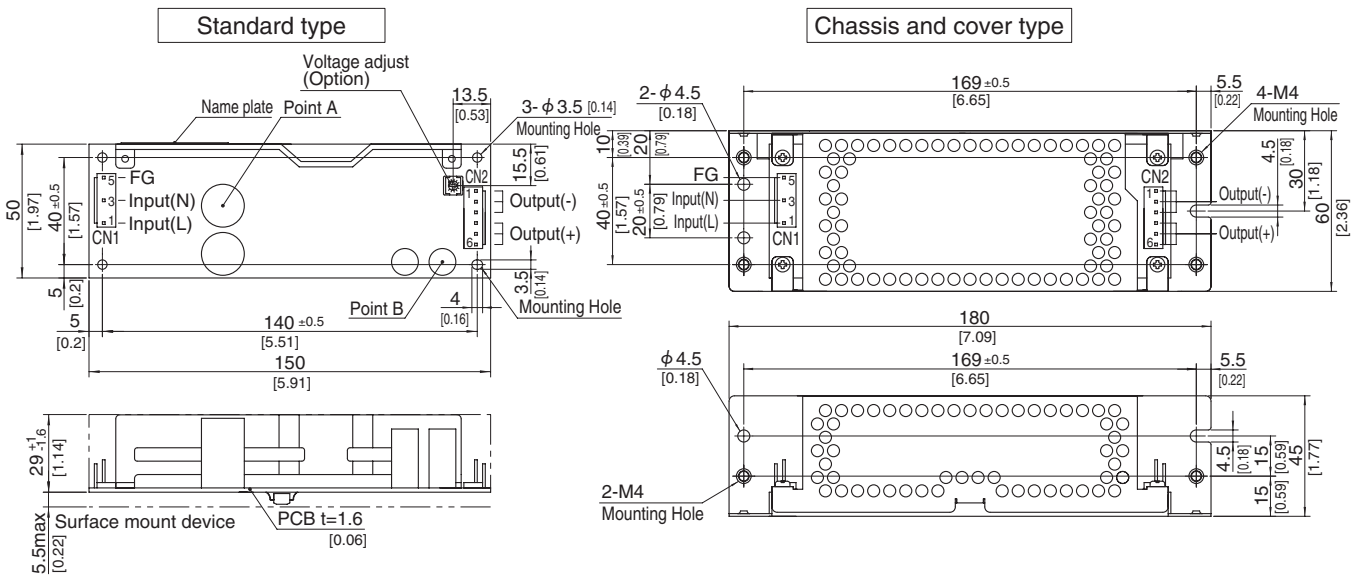

※ This power supply is manufactured by SMD technology. The stress to P.C.B like twisting or bending causes the defect of the unit, so handle the unit with care. Take care for SMD parts on the back to come in contact because of the vibration and not to break down.

※ Mounting torque: 1.5N•m (16kgf•cm) max

※ Use the spacer of 8mm length or more.
 ※ 4 Mounting holes are existing.

I/O Connector	Mating connector	Terminal
CN1	1-1123724-3	Chain 1123721-1
		Loose 1318912-1
CN2	1-1123723-6	Chain 1123721-1
		Loose 1318912-1

(Mfr: Tyco Electronics AMP)

※ I/O Connector is Mfr Tyco Electronics AMP
 ※ Option: -J1: VH(J.S.T) connector type.
 Refer to instruction Manual 6.

<PIN CONNECTION>

CN1		CN2	
Pin No.	Input	Pin No.	Output
1	AC(L)	1 to 3	-V
2			
3	AC(N)	4 to 6	+V
4			
5	FG		

※ Tolerance : ±1 [±0.04]
 ※ Weight : 200g max (with chassis & cover : 410g max)
 ※ PCB material / thickness : CEM3 / 1.6mm [0.06]
 ※ Optional chassis and cover material : Electric galvanizing steel board.
 ※ Dimensions in mm, [] = inches

※ Keep drawing current per pin below 5A for CN2.

LGA100A

LG A 100 A -5 -□

① ② ③ ④ ⑤ ⑥

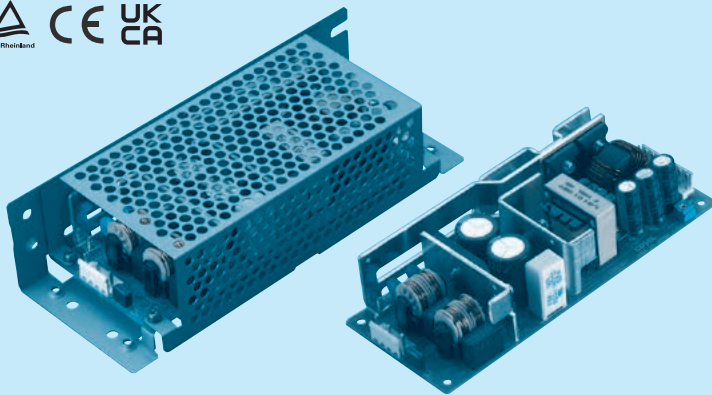
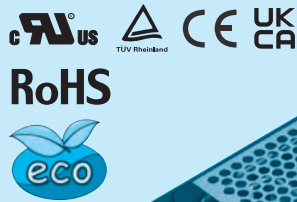

Example recommended EMI/EMC filter
NAC-06-472



High voltage pulse noise type : NAP series
Low leakage current type : NAM series
* A higher current rating EMI/EMC filter may be recommended in view of the other devices that could be connected in parallel with the power supply.

- ① Series name
- ② Single output
- ③ Output wattage
- ④ 100/120V input
- ⑤ Output voltage
- ⑥ Optional
- C :with Coating
- G :Low leakage current
- H :with the function to be acceptable to output peak current (only 24V)
- J1 :VH(J.S.T.)connector type
- S :with Chassis
- SN:with Chassis & cover
- Y :with Potentiometer

This power supply is manufactured by SMD technology. The stress to P.C.B like twisting or bending causes the defect of the unit, so handle the unit with care.
*Make sure necessary tests will be carried out on your end equipment with the power supply installed in accordance with any required EMC/EMI regulations.

MODEL	LGA100A-3R3-Y	LGA100A-5-Y	LGA100A-12	LGA100A-15	LGA100A-24	LGA100A-24-H	LGA100A-48
MAX OUTPUT WATTAGE[W]	66	100	102	105	103.2	103.2	100.8
DC OUTPUT	3.3V 20A	5V 20A	12V 8.5A	15V 7A	24V 4.3A	24V 4.3 (Peak 5.4) A	48V 2.1A

SPECIFICATIONS

	MODEL	LGA100A-3R3-Y	LGA100A-5-Y	LGA100A-12	LGA100A-15	LGA100A-24	LGA100A-24-H	LGA100A-48	
INPUT	VOLTAGE[V]	AC85 - 132 1 φ (Refer to "Derating", Instruction Manual 1 and 3)							
	CURRENT[A]	ACIN 100V 1.6typ (Io=100%)	2.4typ (Io=100%)						
	FREQUENCY[Hz]	47 - 440 (Refer to Instruction Manual 1.1)							
	EFFICIENCY[%]	ACIN 100V 76.0typ (Io=100%)	80.0typ (Io=100%)	83.0typ (Io=100%)	84.0typ (Io=100%)	85.5typ (Io=100%)	85.5typ (Io=100%)	85.5typ (Io=100%)	
	INRUSH CURRENT[A]	ACIN 100V 15typ (Io=100%, More than 10sec. to re-start)							
	LEAKAGE CURRENT[ma]	0.5max (ACIN 100V, 60Hz, Io=100%, According to IEC62368-1 and DEN-AN)							
OUTPUT	VOLTAGE[V]	3.3	5	12	15	24	24	48	
	CURRENT[A]	*3 20.0	20.0	8.5	7.0	4.3	4.3 (Peak 5.4)	2.1	
	LINE REGULATION[mV]	20max	20max	48max	60max	96max	96max	192max	
	LOAD REGULATION[mV]	40max	40max	100max	120max	150max	150max	300max	
	RIPPLE[mVp-p]	0 to +50°C *1	80max	80max	120max	120max	120max	240max	150max
		-10 - 0°C *1	140max	140max	160max	160max	160max	320max	200max
	RIPPLE NOISE[mVp-p]	0 to +50°C *1	120max	120max	150max	150max	150max	300max	350max
		-10 - 0°C *1	160max	160max	180max	180max	180max	360max	400max
	TEMPERATURE REGULATION[mV]	0 to +50°C	50max	50max	120max	150max	240max	240max	480max
		-10 to +50°C	60max	60max	150max	180max	290max	290max	600max
	DRIFT[mV]	*2 20max	20max	48max	60max	96max	96max	192max	
	START-UP TIME[ms]	200max (ACIN 100V, Io=100%)							
	HOLD-UP TIME[ms]	20typ (ACIN 100V, Io=100%)							
OUTPUT VOLTAGE ADJUSTMENT RANGE[V]	2.85 - 3.63	4.50 - 5.50	Fixed ("Y" which can be adjusted the output is available as optional ±10%)						
OUTPUT VOLTAGE SETTING[V]	3.30 - 3.40	5.00 - 5.15	11.50 - 12.50	14.40 - 15.60	23.00 - 25.00	23.00 - 25.00	46.00 - 50.00		
PROTECTION CIRCUIT AND OTHERS	OVERCURRENT PROTECTION	Works over 105% of rating (works over 101% of peak current at option -H) and recovers automatically							
	OVERVOLTAGE PROTECTION	4.00 - 5.25	5.75 - 7.00	13.80 - 16.80	17.30 - 21.00	27.60 - 35.00	27.60 - 35.00	55.20 - 67.20	
	OPERATING INDICATION	Not provided							
	REMOTE SENSING	Not provided							
ISOLATION	REMOTE ON/OFF	Not provided							
	INPUT-OUTPUT	AC2,000V 1minute, Cutoff current = 10mA, DC500V 50MΩ min (At Room Temperature)							
	INPUT-FG	AC2,000V 1minute, Cutoff current = 10mA, DC500V 50MΩ min (At Room Temperature)							
ENVIRONMENT	OUTPUT-FG	AC500V 1minute, Cutoff current = 25mA, DC500V 50MΩ min (At Room Temperature)							
	OPERATING TEMP., HUMID. AND ALTITUDE	-10 to +60°C, 20 - 90%RH (Non condensing) (Refer to "Derating", Instruction Manual 3), 3,000m (10,000feet) max							
	STORAGE TEMP., HUMID. AND ALTITUDE	-20 to +75°C, 20 - 90%RH (Non condensing), 9,000m (30,000feet) max							
	VIBRATION	10 - 55Hz, 19.6m/s ² (2G), 3minutes period, 60minutes each along X, Y and Z axis							
SAFETY AND NOISE REGULATIONS	IMPACT	196.1m/s ² (20G), 11ms, once each X, Y and Z axis							
	AGENCY APPROVALS	UL60950-1, C-UL (CSA60950-1), EN62368-1 Complies with DEN-AN							
	CONDUCTED NOISE	Complies with FCC-B, VCCI-B, CISPR-B, EN55011-B, EN55022-B							
OTHERS	CASE SIZE/WEIGHT	62 X 35.5 X 155mm [2.44 X 1.4 X 6.1 inches] (W X H X D) / 300g max (with chassis & cover : 530g max)							
	COOLING METHOD	Convection (Refer to "Derating", Instruction Manual 3)							

*1 This is the value that measured on measuring board with capacitor of 22 μ F at 150mm from output terminal.
Measured by 20MHz oscilloscope or Ripple-Noise meter (Equivalent to KEISOKU-GIKEN: RM-103).
*2 Drift is the change in DC output for an eight hour period after a half-hour warm-up at 25°C, with the input voltage held constant at the rated input/output.
*3 Peak loading for 10sec. And Duty 35% max. or less is acceptable if the total wattage is less than the rated wattage.
Refer to instruction Manual 6. In detail.
* Avoid prolonged use under over - load.
* Parallel operation with other model is not possible.
* Derating is required when operated with chassis and cover.
* A sound may occur from power supply at pulse loading.

Block diagram

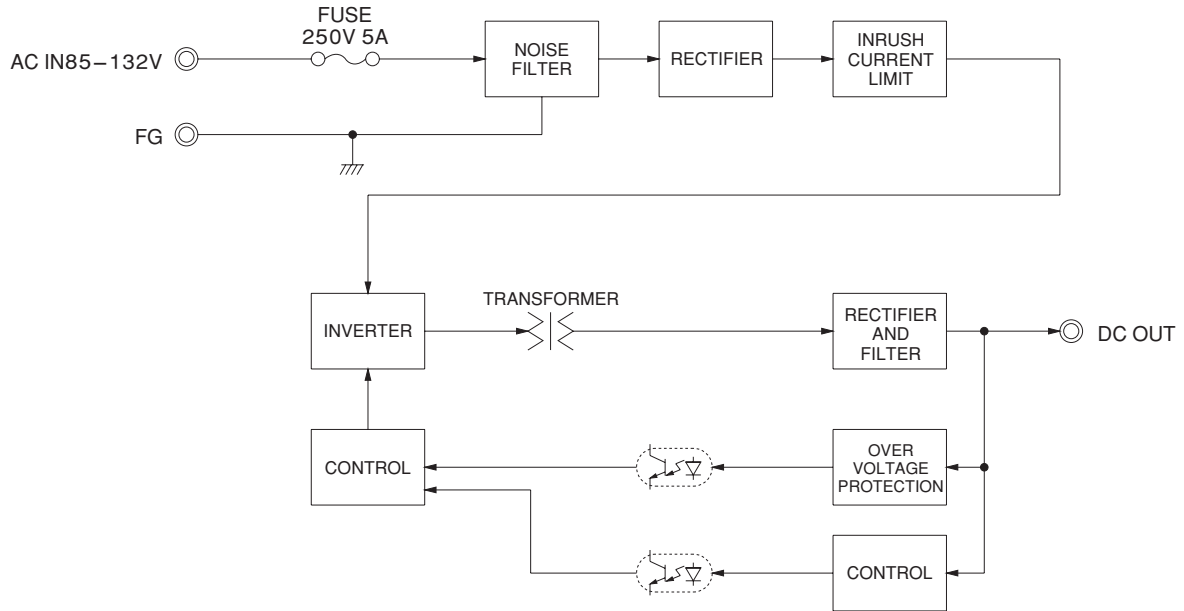

LGA

External view

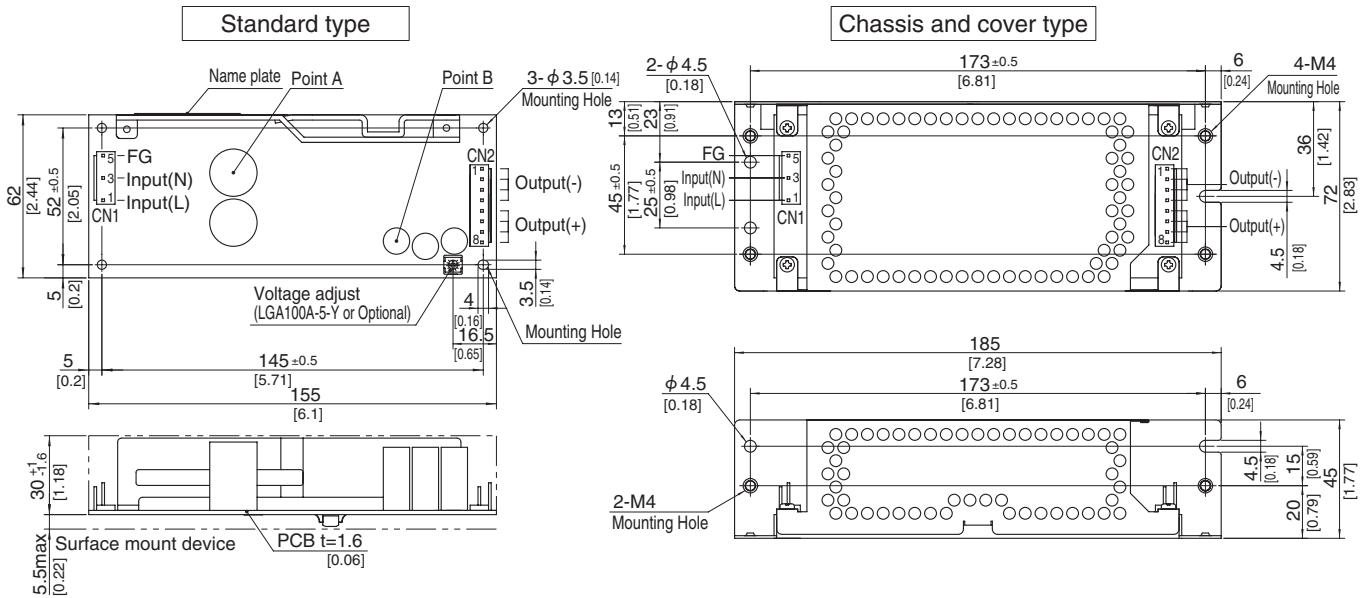

- ※ This power supply is manufactured by SMD technology. The stress to P.C.B like twisting or bending causes the defect of the unit, so handle the unit with care. Take care for SMD parts on the back to come in contact because of the vibration and not to break down.
- ※ Use the spacer of 8mm length or more.
- ※ 4 Mounting holes are existing.

※ Mounting torque: 1.5N•m (16kgf•cm) max

I/O Connector	Mating connector	Terminal
CN1	1-1123724-3	Chain 1123721-1
		Loose 1318912-1
CN2	1-1123723-8	Chain 1123721-1
		Loose 1318912-1

(Mfr: Tyco Electronics AMP)

- ※ I/O Connector is Mfr Tyco Electronics AMP
- ※ Option: J1: VH(J.S.T) connector type. Refer to instruction Manual 6.

<PIN CONNECTION>

Pin No.	Input
1	AC(L)
2	
3	AC(N)
4	
5	FG

Pin No.	Output
1 to 4	-V
5 to 8	+V

※ Tolerance : ±1 [±0.04]

※ Weight : 300g max (with chassis & cover : 530g max)

※ PCB material / thickness : CEM3 / 1.6mm [0.06]

※ Optional chassis and cover material : Electric galvanizing steel board.

※ Dimensions in mm, [] = inches

※ Keep drawing current per pin below 5A for CN2.

LGA150A

LG A 150 A -5 -□

① ② ③ ④ ⑤ ⑥

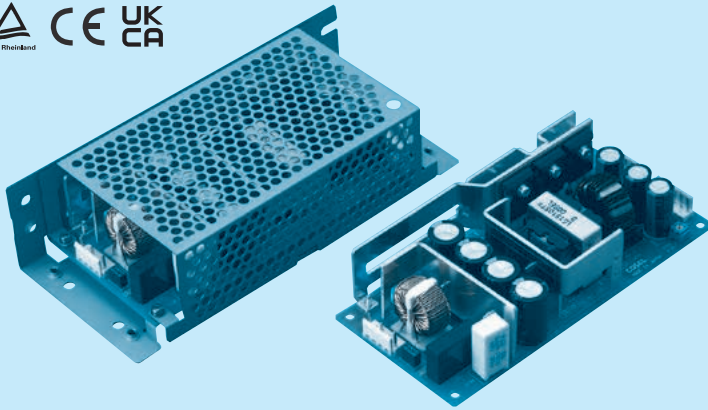
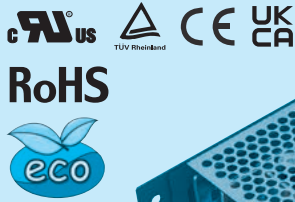

Example recommended EMI/EMC filter
NAC-06-472



High voltage pulse noise type : NAP series
Low leakage current type : NAM series
* A higher current rating EMI/EMC filter may be recommended in view of the other devices that could be connected in parallel with the power supply.

- ① Series name
- ② Single output
- ③ Output wattage
- ④ 100/120V input
- ⑤ Output voltage
- ⑥ Optional
- C :with Coating
- G :Low leakage current
- H :with the function to be acceptable to output peak current (only 24V)
- J1 :VH(J.S.T.)connector type
- S :with Chassis
- SN:with Chassis & cover
- Y :with Potentiometer

This power supply is manufactured by SMD technology. The stress to P.C.B like twisting or bending causes the defect of the unit, so handle the unit with care.
*Make sure necessary tests will be carried out on your end equipment with the power supply installed in accordance with any required EMC/EMI regulations.

MODEL	LGA150A-3R3-Y	LGA150A-5-Y	LGA150A-12	LGA150A-15	LGA150A-24	LGA150A-24-H	LGA150A-48
MAX OUTPUT WATTAGE[W]	99	150	150	150	151.2	151.2	153.6
DC OUTPUT	3.3V 30A	5V 30A	12V 12.5A	15V 10A	24V 6.3A	24V 6.3 (Peak 7.9) A	48V 3.2A

SPECIFICATIONS

MODEL	LGA150A-3R3-Y	LGA150A-5-Y	LGA150A-12	LGA150A-15	LGA150A-24	LGA150A-24-H	LGA150A-48		
INPUT	VOLTAGE[V]								
	AC85 - 132 1 φ (Refer to "Derating", Instruction Manual 1 and 3)								
	CURRENT[A]	ACIN 100V 2.6typ (Io=100%)		3.6typ (Io=100%)					
	FREQUENCY[Hz]	47 - 440 (Refer to Instruction Manual 1.1)							
	EFFICIENCY[%]	ACIN 100V 76.0typ (Io=100%)	82.0typ (Io=100%)	84.5typ (Io=100%)	85.5typ (Io=100%)	87.0typ (Io=100%)	87.0typ (Io=100%)	87.0typ (Io=100%)	
INRUSH CURRENT[A]	ACIN 100V 15 /15 typ (Primary / Secondary Surge Current, Io=100%, More than 10sec. to re-start)								
LEAKAGE CURRENT[ma]	0.5max (ACIN 100V, 60Hz, Io=100%, According to IEC62368-1 and DEN-AN)								
OUTPUT	VOLTAGE[V]	3.3	5	12	15	24	24	48	
	CURRENT[A]	*3 30.0	30.0	12.5	10.0	6.3	6.3 (Peak 7.9)	3.2	
	LINE REGULATION[mV]	20max	20max	48max	60max	96max	96max	192max	
	LOAD REGULATION[mV]	40max	40max	100max	120max	150max	150max	300max	
	RIPPLE[mVp-p]	0 to +40°C *1	80max	80max	120max	120max	120max	240max	150max
		-10 - 0°C *1	140max	140max	160max	160max	160max	320max	200max
	RIPPLE NOISE[mVp-p]	0 to +40°C *1	120max	120max	150max	150max	150max	300max	350max
		-10 - 0°C *1	160max	160max	180max	180max	180max	360max	400max
	TEMPERATURE REGULATION[mV]	0 to +40°C	50max	50max	120max	150max	240max	240max	480max
		-10 to +40°C	60max	60max	150max	180max	290max	290max	600max
	DRIFT[mV]	*2 20max	20max	48max	60max	96max	96max	192max	
	START-UP TIME[ms]	200max (ACIN 100V, Io=100%)							
HOLD-UP TIME[ms]	20typ (ACIN 100V, Io=100%)								
OUTPUT VOLTAGE ADJUSTMENT RANGE[V]	2.85 - 3.63	4.50 - 5.50	Fixed ("Y" which can be adjusted the output is available as optional ± 10%)						
OUTPUT VOLTAGE SETTING[V]	3.30 - 3.40	5.00 - 5.15	11.50 - 12.50	14.40 - 15.60	23.00 - 25.00	23.00 - 25.00	46.00 - 50.00		
PROTECTION CIRCUIT AND OTHERS	OVERCURRENT PROTECTION	Works over 105% of rating (works over 101% of peak current at option -H) and recovers automatically							
	OVERVOLTAGE PROTECTION	4.00 - 5.25	5.75 - 7.00	13.80 - 16.80	17.30 - 21.00	27.60 - 35.00	27.60 - 35.00	55.20 - 67.20	
	OPERATING INDICATION	Not provided							
	REMOTE SENSING	Not provided							
ISOLATION	REMOTE ON/OFF	Not provided							
	INPUT-OUTPUT	AC2,000V 1minute, Cutoff current = 10mA, DC500V 50MΩ min (At Room Temperature)							
	INPUT-FG	AC2,000V 1minute, Cutoff current = 10mA, DC500V 50MΩ min (At Room Temperature)							
ENVIRONMENT	OUTPUT-FG	AC500V 1minute, Cutoff current = 25mA, DC500V 50MΩ min (At Room Temperature)							
	OPERATING TEMP., HUMID. AND ALTITUDE	-10 to +60°C, 20 - 90%RH (Non condensing) (Refer to "Derating", Instruction Manual 3), 3,000m (10,000feet) max							
	STORAGE TEMP., HUMID. AND ALTITUDE	-20 to +75°C, 20 - 90%RH (Non condensing), 9,000m (30,000feet) max							
	VIBRATION	10 - 55Hz, 19.6m/s ² (2G), 3minutes period, 60minutes each along X, Y and Z axis							
SAFETY AND NOISE REGULATIONS	IMPACT	196.1m/s ² (20G), 11ms, once each X, Y and Z axis							
	AGENCY APPROVALS	UL60950-1, C-UL (CSA60950-1), EN62368-1 Complies with DEN-AN							
	CONDUCTED NOISE	Complies with FCC-B, VCCI-B, CISPR-B, EN55011-B, EN55022-B							
OTHERS	CASE SIZE/WEIGHT	75 X 39 X 160mm [2.95 X 1.54 X 6.3 inches] (W X H X D) / 420g max (with chassis & cover : 650g max)							
	COOLING METHOD	Convection (Refer to "Derating", Instruction Manual 3)							

*1 This is the value that measured on measuring board with capacitor of 22 μF at 150mm from output terminal.
Measured by 20MHz oscilloscope or Ripple-Noise meter (Equivalent to KEISOKU-GIKEN: RM-103).
*2 Drift is the change in DC output for an eight hour period after a half-hour warm-up at 25°C, with the input voltage held constant at the rated input/output.
*3 Peak loading for 10sec. And Duty 35% max. or less is acceptable if the total wattage is less than the rated wattage.
Refer to instruction Manual 6. In detail.
* Avoid prolonged use under over - load.
* Parallel operation with other model is not possible.
* Derating is required when operated with chassis and cover.
* A sound may occur from power supply at pulse loading.

Block diagram

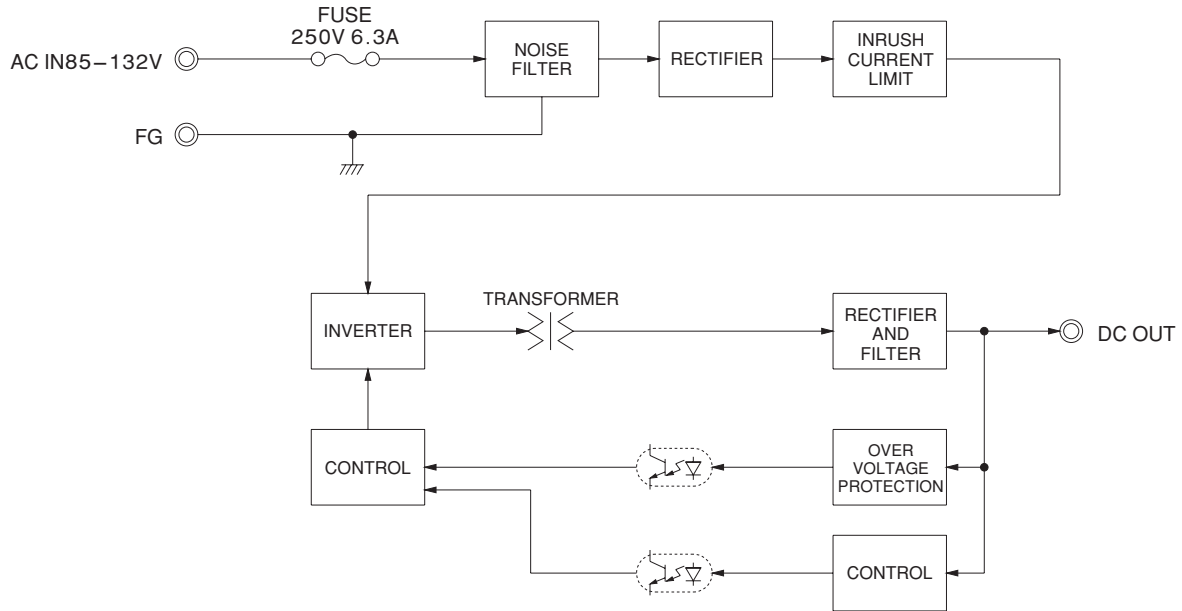

LGA

External view

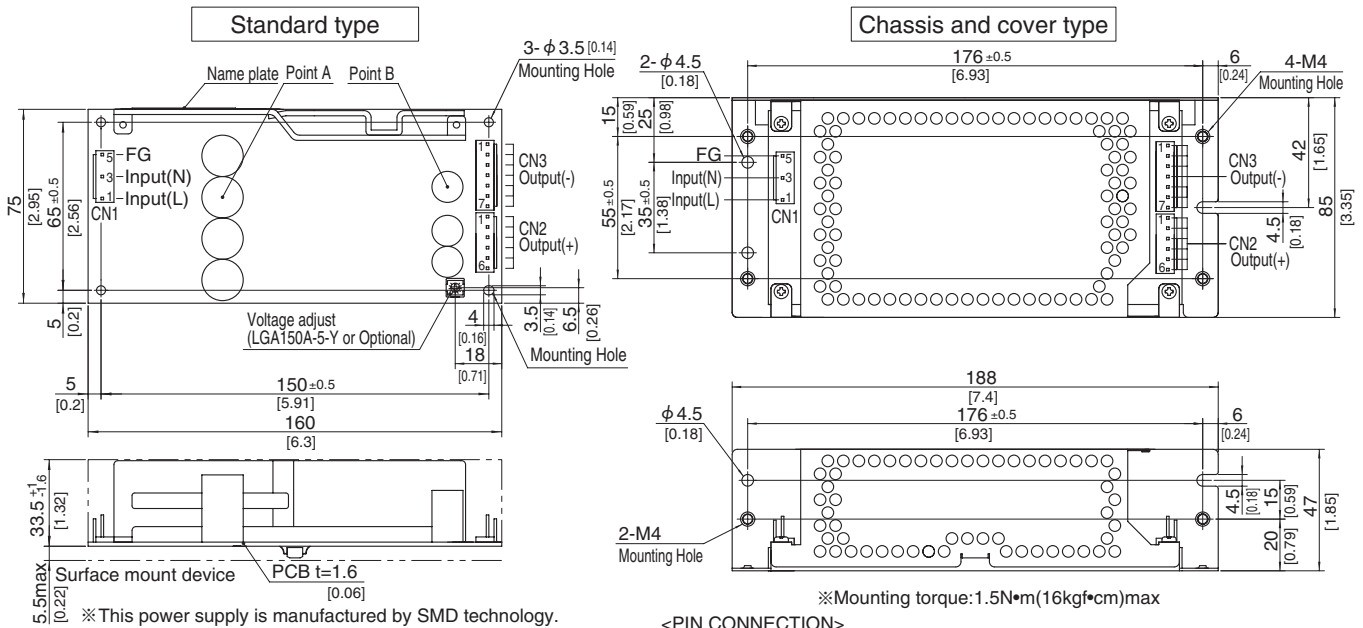

- ※ This power supply is manufactured by SMD technology. The stress to P.C.B like twisting or bending causes the defect of the unit, so handle the unit with care. Take care for SMD parts on the back to come in contact because of the vibration and not to break down.
- ※ Use the spacer of 8mm length or more.
- ※ 4 mounting holes are existing.

I/O Connector	Mating connector	Terminal
CN1	1-1123724-3	Chain 1123721-1
		Loose 1318912-1
CN2	1-1123723-6	Chain 1123721-1
		Loose 1318912-1
CN3	1-1123723-7	Chain 1123721-1
		Loose 1318912-1

(Mfr: Tyco Electronics AMP)

- ※ I/O Connector is Mfr Tyco Electronics AMP
- ※ Option: -J1: VH(J.S.T) connector type. Refer to instruction Manual 6.

<PIN CONNECTION>

CN1		CN2		CN3	
Pin No.	Input	Pin No.	Output	Pin No.	Output
1	AC(L)	1 to 6	+V	1 to 7	-V
2					
3	AC(N)				
4					
5	FG				

※ Keep drawing current per pin below 5A for CN2, CN3.

- ※ Tolerance : ±1 [±0.04]
- ※ Weight : 420g max (with chassis & cover : 650g max)
- ※ PCB material / thickness : CEM3 / 1.6mm [0.06]
- ※ Optional chassis and cover material : Electric galvanizing steel board.
- ※ Dimensions in mm, []=inches

LGA240A

LG A 240 A -5 -□

① ② ③ ④ ⑤ ⑥

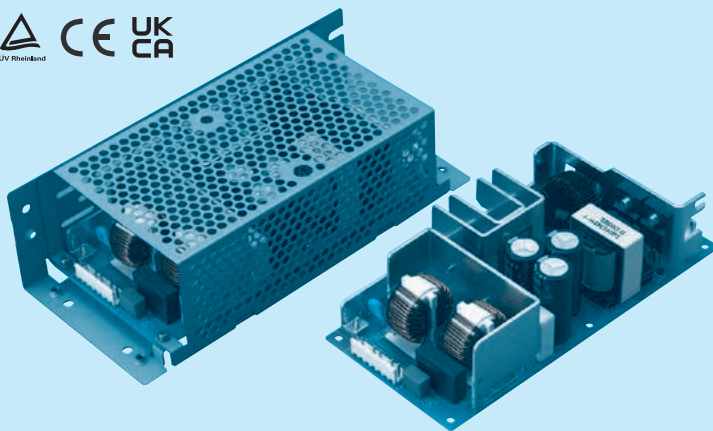
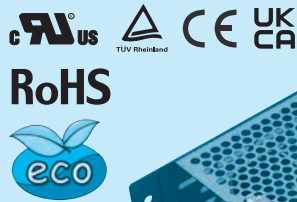

Example recommended EMI/EMC filter
NAC-16-472



High voltage pulse noise type : NAP series
Low leakage current type : NAM series
* A higher current rating EMI/EMC filter may be recommended in view of the other devices that could be connected in parallel with the power supply.

- ① Series name
- ② Single output
- ③ Output wattage
- ④ 100/120V input
- ⑤ Output voltage
- ⑥ Optional
- C :with Coating
- G :Low leakage current
- H :with the function to be acceptable to output peak current (only 24V)
- J1 :VH(J.S.T.)connector type
- S :with Chassis
- SN:with Chassis & cover
- T :Vertical terminal block
- Y :with Potentiometer

This power supply is manufactured by SMD technology. The stress to P.C.B like twisting or bending causes the defect of the unit, so handle the unit with care.
*Make sure necessary tests will be carried out on your end equipment with the power supply installed in accordance with any required EMC/EMI regulations.

MODEL	LGA240A-24	LGA240A-24-H
MAX OUTPUT WATTAGE[W]	240	240
DC OUTPUT	24V 10A	24V 10 (Peak 12.5) A

SPECIFICATIONS

	MODEL	LGA240A-24	LGA240A-24-H	
INPUT	VOLTAGE[V]	AC85 - 132 1 φ (Refer to "Derating", Instruction Manual 1 and 3)		
	CURRENT[A]	ACIN 100V	5.0typ (Io=100%)	
	FREQUENCY[Hz]	47 - 440 (Refer to Instruction Manual 1.1)		
	EFFICIENCY[%]	ACIN 100V	86.5typ (Io=100%)	86.5typ (Io=100%)
	INRUSH CURRENT[A]	ACIN 100V	15 / 20 typ (Primary / Secondary Surge Current, Io=100%, More than 10sec. to re-start)	
	LEAKAGE CURRENT[ma]	0.5max (ACIN 100V, 60Hz, Io=100%, According to IEC62368-1 and DEN-AN)		
OUTPUT	VOLTAGE[V]	24		
	CURRENT[A]	*3	10.0	10.0 (Peak 12.5)
	LINE REGULATION[mV]	96max		
	LOAD REGULATION[mV]	150max		
	RIPPLE[mVp-p]	0 to +40°C *1	120max	240max
		-10 - 0°C *1	160max	320max
	RIPPLE NOISE[mVp-p]	0 to +40°C *1	150max	300max
		-10 - 0°C *1	180max	360max
	TEMPERATURE REGULATION[mV]	0 to +40°C	240max	240max
		-10 to +40°C	290max	290max
	DRIFT[mV]	*2	96max	96max
	START-UP TIME[ms]	200max (ACIN 100V, Io=100%)		
	HOLD-UP TIME[ms]	20typ (ACIN 100V, Io=100%)		
OUTPUT VOLTAGE ADJUSTMENT RANGE[V]	Fixed ("Y" which can be adjusted the output is available as optional ±10%)			
OUTPUT VOLTAGE SETTING[V]	23.00 - 25.00	23.00 - 25.00		
PROTECTION CIRCUIT AND OTHERS	OVERCURRENT PROTECTION	Works over 105% of rating (works over 101% of peak current at option -H) and recovers automatically		
	OVERVOLTAGE PROTECTION	27.60 - 35.00	27.60 - 35.00	
	OPERATING INDICATION	Not provided		
	REMOTE SENSING	Not provided		
ISOLATION	REMOTE ON/OFF	Not provided		
	INPUT-OUTPUT	AC2,000V 1minute, Cutoff current = 10mA, DC500V 50MΩ min (At Room Temperature)		
	INPUT-FG	AC2,000V 1minute, Cutoff current = 10mA, DC500V 50MΩ min (At Room Temperature)		
ENVIRONMENT	OUTPUT-FG	AC500V 1minute, Cutoff current = 25mA, DC500V 50MΩ min (At Room Temperature)		
	OPERATING TEMP., HUMID. AND ALTITUDE	-10 to +60°C, 20 - 90%RH (Non condensing) (Refer to "Derating", Instruction Manual 3), 3,000m (10,000feet) max		
	STORAGE TEMP., HUMID. AND ALTITUDE	-20 to +75°C, 20 - 90%RH (Non condensing), 9,000m (30,000feet) max		
	VIBRATION	10 - 55Hz, 19.6m/s ² (2G), 3minutes period, 60minutes each along X, Y and Z axis		
SAFETY AND NOISE REGULATIONS	IMPACT	196.1m/s ² (20G), 11ms, once each X, Y and Z axis		
	AGENCY APPROVALS	UL60950-1, C-UL (CSA60950-1), EN62368-1 Complies with DEN-AN		
	CONDUCTED NOISE	Complies with FCC-B, VCCI-B, CISPR-B, EN55011-B, EN55022-B		
OTHERS	CASE SIZE/WEIGHT	84 × 48.5 × 180mm [3.31 × 1.91 × 7.09 inches] (W × H × D) / 590g max (with chassis & cover : 880g max)		
	COOLING METHOD	Convection (Refer to "Derating", Instruction Manual 3)		

*1 This is the value that measured on measuring board with capacitor of 22 μF at 150mm from output terminal.
Measured by 20MHz oscilloscope or Ripple-Noise meter (Equivalent to KEISOKU-GIKEN: RM-103).
*2 Drift is the change in DC output for an eight hour period after a half-hour warm-up at 25°C, with the input voltage held constant at the rated input/output.
*3 Peak loading for 10sec. And Duty 35% max. or less is acceptable if the total wattage is less than the rated wattage.
Refer to instruction Manual 6. In detail.
* Avoid prolonged use under over - load.
* Parallel operation with other model is not possible.
* Derating is required when operated with chassis and cover.
* A sound may occur from power supply at pulse loading.

Block diagram

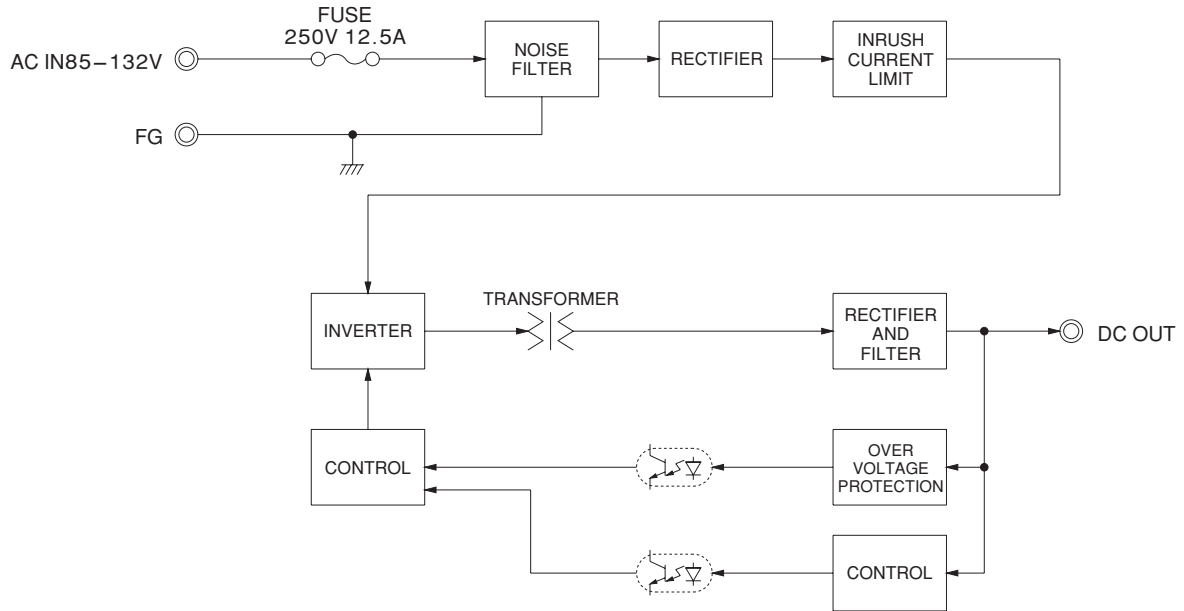

LGA

External view

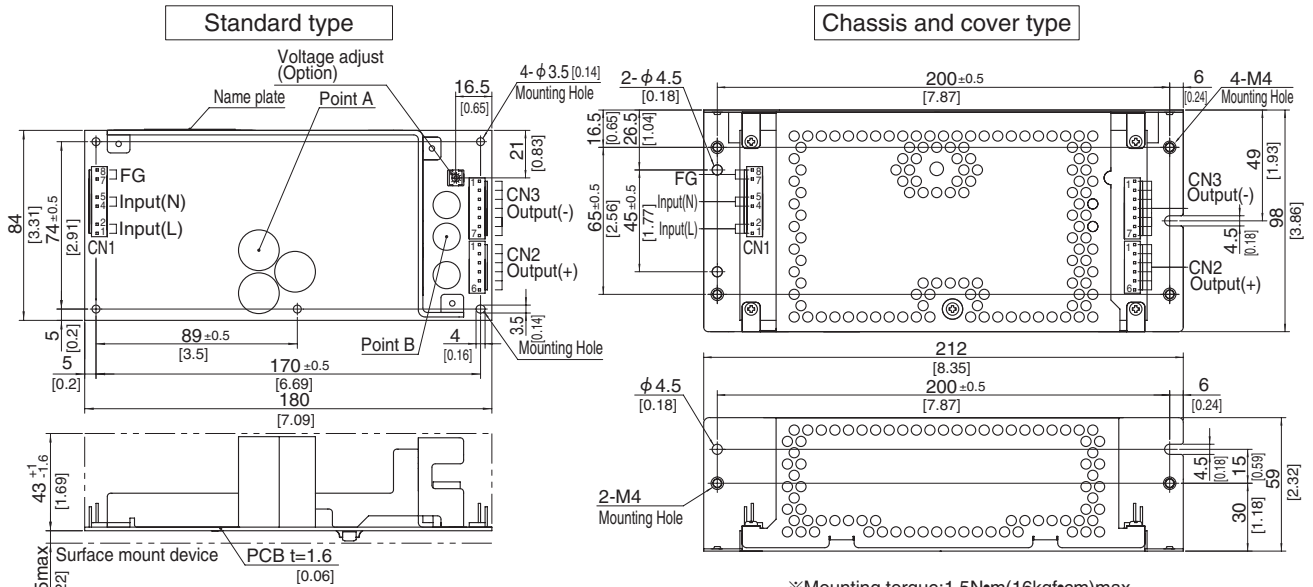

※Mounting torque: 1.5N•m(16kgf•cm)max

※ This power supply is manufactured by SMD technology.

The stress to P.C.B like twisting or bending causes the defect of the unit, so handle the unit with care.

Take care for SMD parts on the back to come in contact because of the vibration and not to break down.

※ Use the spacer of 8mm length or more.

※ 5 Mounting holes are existing.

I/O Connector	Mating connector	Terminal	
CN1	7-1565036-6	1-1123722-8	Chain 1123721-1
			Loose 1318912-1
CN2	1-1123723-6	1-1123722-6	Chain 1123721-1
			Loose 1318912-1
CN3	1-1123723-7	1-1123722-7	Chain 1123721-1
			Loose 1318912-1

(Mfr: Tyco Electronics AMP)

※I/O Connector is Mfr Tyco Electronics AMP

※Option:-J1:VH(J.S.T) connector type.
Refer to instruction Manual 6.

<PIN CONNECTION>

CN1		CN2		CN3	
Pin No.	Input	Pin No.	Output	Pin No.	Output
1, 2	AC(L)	1 to 6	+V	1 to 7	-V
3					
4, 5	AC(N)				
6					
7, 8	FG				

※Keep drawing current per pin below 5A for CN1, CN2 and CN3.

※Tolerance : ±1 [±0.04]

※Weight : 590g max (with chassis & cover : 880g max)

※PCB material / thickness : CEM3 / 1.6mm [0.06]

※Optional chassis and cover material : Electric galvanizing steel board.

※Dimensions in mm, []=inches

Assembling and Installation Method

Installation method

■ This power supply is manufactured by SMD technology. The stress to P.C.B like twisting or bending causes the defect of the unit, so handle the unit with care.

■ In case of metal chassis, keep the distance between d1 & d2 for to insulate between lead of component and metal chassis, use the spacer of 8mm or more between d1. If it is less than d1 & d2, insert the insulation sheet between power supply and metal chassis.

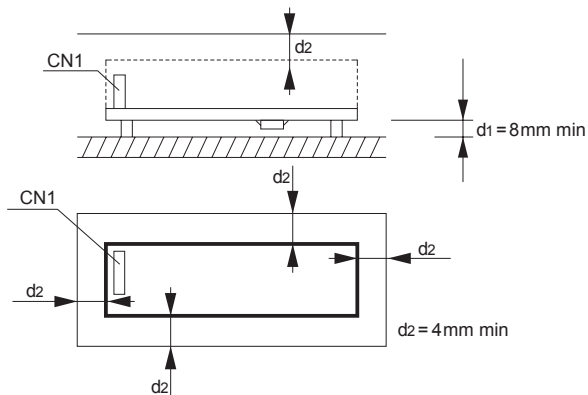

■ (F) mounting should be operated by Forced air.

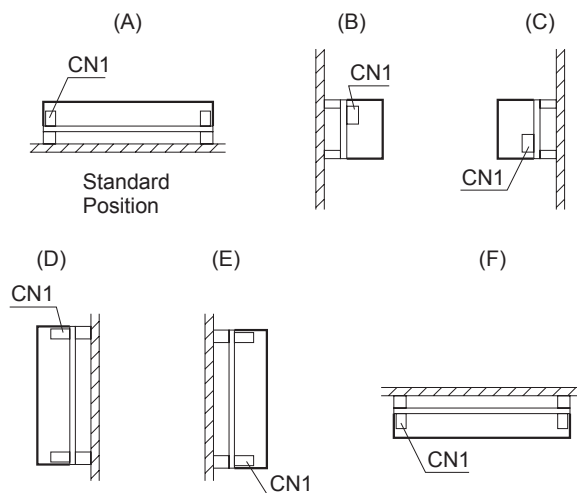

Mounting screw

■ The mounting screw should be M3. The hatched area shows the allowance of metal parts for mounting.

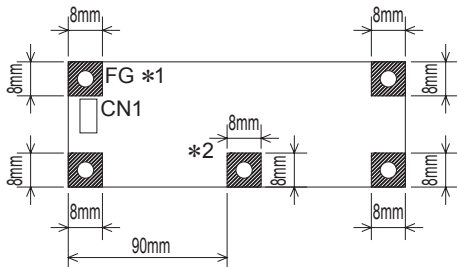

*1 Recommendation to electrically connect FG to metal reducing noise.
 *2 LGA240A only Refer to External view for location

■ If metallic fittings are used on the component side of the board, ensure there is no contact with surface mounted components.

Derating

● Derating curve for input voltage

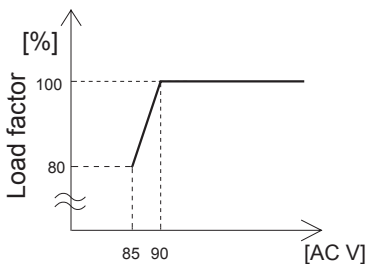

Derating

● LGA50A-3R3-Y, -5, -12, -15
Ambient temperature derating curve

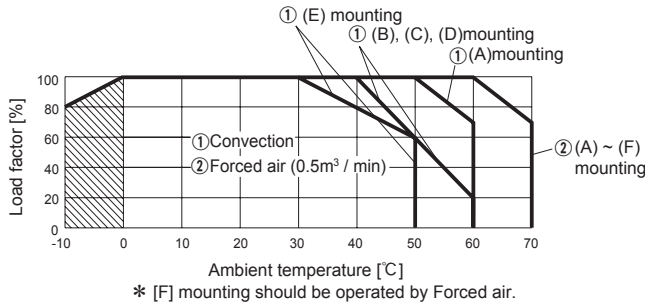

● LGA50A-3R3-Y, -5, -12, -15 -SN (with Chassis & Cover)
Ambient temperature derating curve

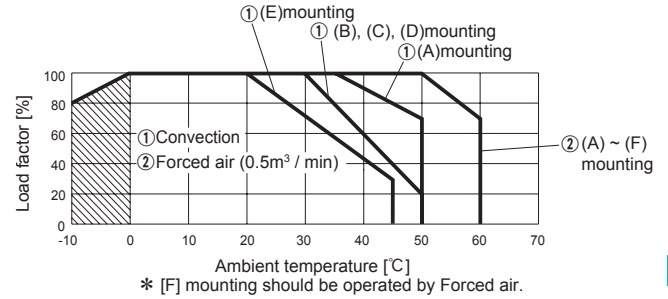

LGA

● LGA50A-24, -48
Ambient temperature derating curve

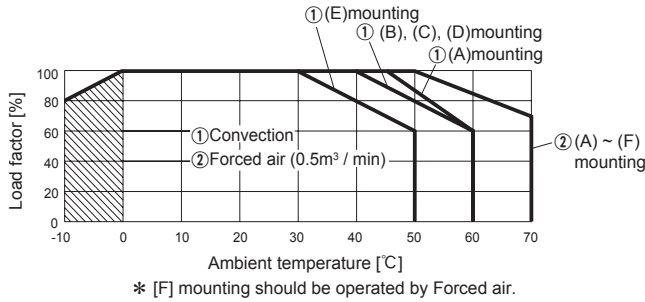

● LGA50A-24, -48 -SN (with Chassis & Cover)
Ambient temperature derating curve

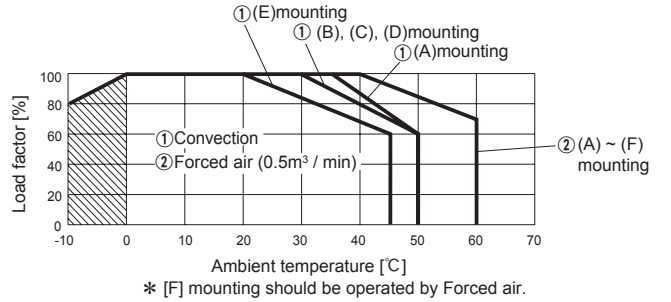

● LGA75A-□
Ambient temperature derating curve

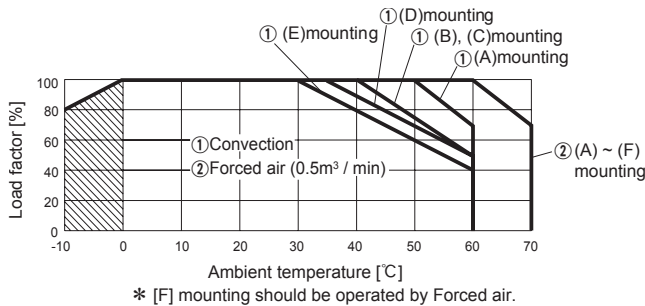

● LGA75A-□-SN (with Chassis & Cover)
Ambient temperature derating curve

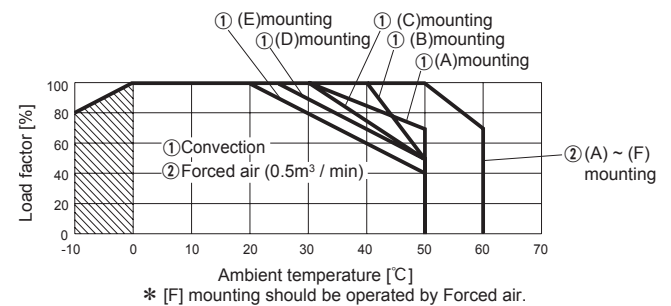

● LGA100A-□
Ambient temperature derating curve

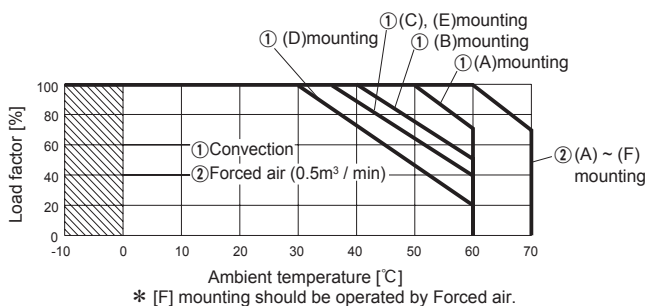

● LGA100A-□-SN (with Chassis & Cover)
Ambient temperature derating curve

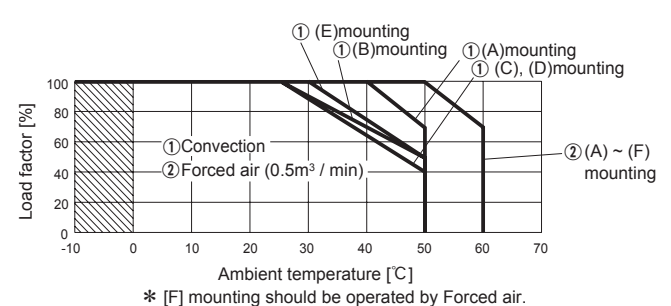

Derating

● LGA150A-□ Ambient temperature derating curve

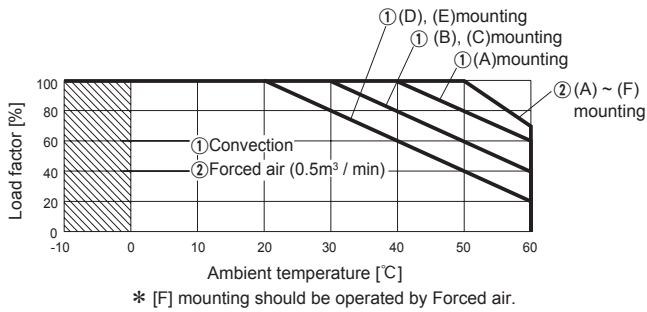

● LGA150A-□-SN (with Chassis & Cover) Ambient temperature derating curve

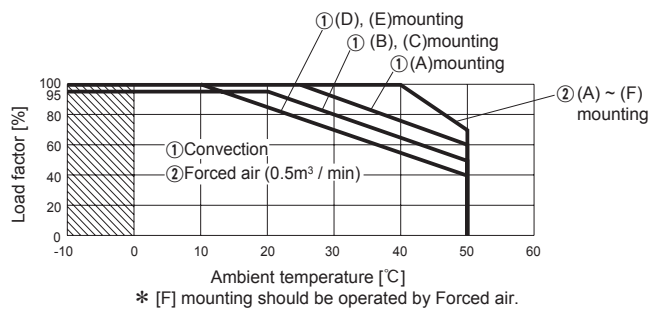

● LGA240A-□ Ambient temperature derating curve

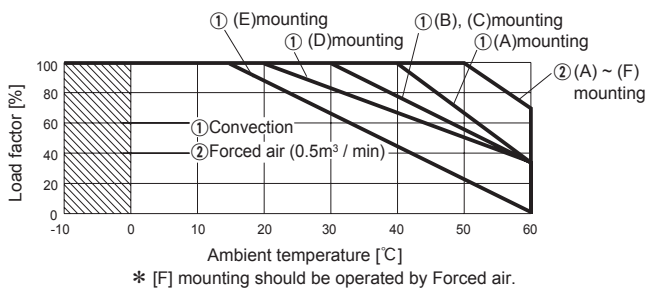

● LGA240A-□-SN (with Chassis & Cover) Ambient temperature derating curve

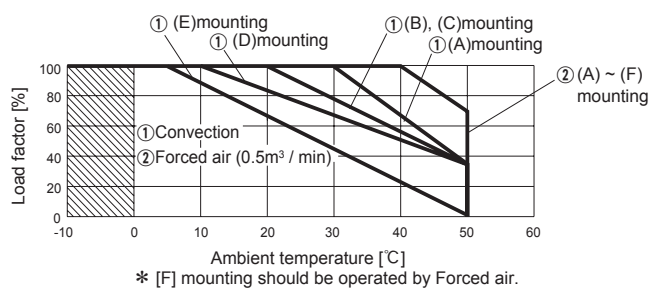

■ The operative ambient temperature is different by with / without chassis cover or mounting position.

Note: In the hatched area, the specification of Ripple, Ripple Noise is different from other area.

■ Make sure the temperature at point A and point B is less than the temperatures shown in Instruction Manual 3.

■ The ambient temperature should be measured 5 to 10 cm away from the power supply so that it won't be influenced by the heat from the power supply. Please consult us for more details.

Instruction Manual

◆ It is necessary to read the "Instruction Manual" and "Before using our product" before you use our product.

Instruction Manual <https://www.cosel.co.jp/redirect/catalog/en/LGA/>
 Before using our product <https://en.cosel.co.jp/technical/caution/index.html>

LGA



NOTICE



Basic Characteristics Data

Model	Circuit method	Switching frequency [kHz]	Input current *1 [A]	Inrush current protection	PCB/Pattern			Series/Parallel operation availability *2	
					Material	Single sided	Double sided	Series operation	Parallel operation
LGA50A	Forward Converter	130	1.3	Thermistor	CEM-3	Yes		Yes	No
LGA75A	Forward Converter	130	1.7	Thermistor	CEM-3	Yes		Yes	No
LGA100A	Forward Converter	130	2.4	SCR	CEM-3	Yes		Yes	No
LGA150A	Forward Converter	130	3.6	SCR	CEM-3	Yes		Yes	No
LGA240A	Forward Converter	130	5.0	SCR	CEM-3	Yes		Yes	No

*1 The value of input current is at ACIN 100V and rated load.

*2 Refer to Instruction Manual 2.



LHP-series

LHP

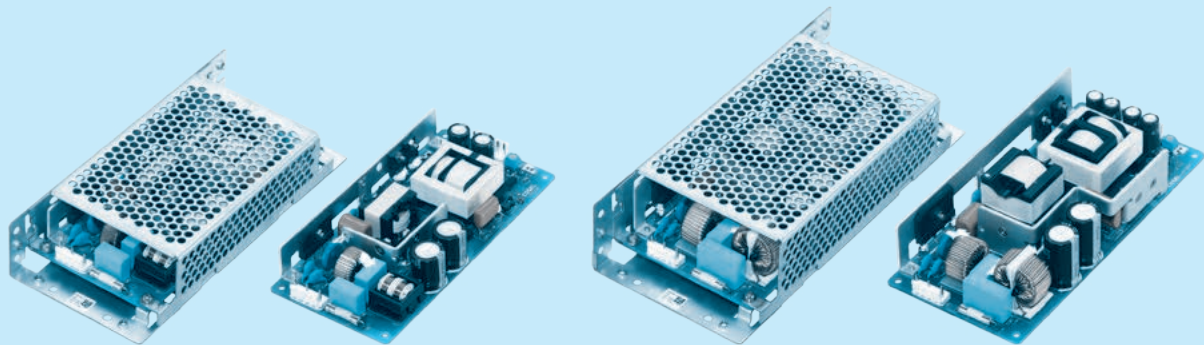

Feature

- OVC III
- High power & high peak power
- High efficiency
- Low profile
- Active Power factor correction
- Harmonic attenuator (Complies with IEC61000-3-2)
- Universal input (85 - 264 VAC)
- Built-in inrush current, over current, over voltage protection

Safety agency approvals

- UL62368-1, C-UL (equivalent to CAN/CSA-C22.2 No.62368-1), EN62368-1
- EN62477-1 (OVC III)
- Complies with DEN-AN
- UL508 (Optional)

5-year warranty (refer to Instruction Manual)

CE marking

- Low Voltage Directive
- RoHS Directive

UKCA marking

- Electrical Equipment Safety Regulations
- RoHS Regulations

EMI

- Complies with FCC-B, CISPR11-B, CISPR32-B, EN55011-B, EN55032-B, VCCI-B

EMS Compliance : EN61204-3, EN61000-6-2

- EN61000-4-2
- EN61000-4-3
- EN61000-4-4
- EN61000-4-5
- EN61000-4-6
- EN61000-4-8
- EN61000-4-11

LHP150F

LH P 150 F -□□ -□

① ② ③ ④ ⑤ ⑥

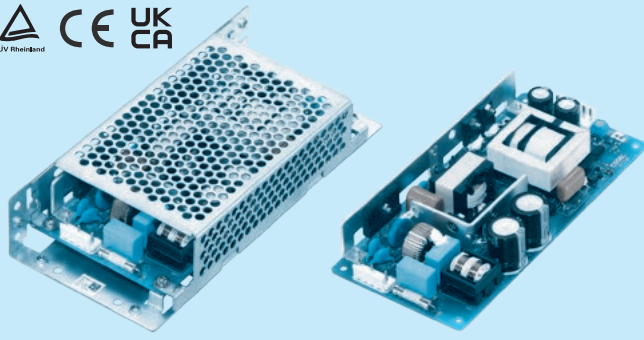
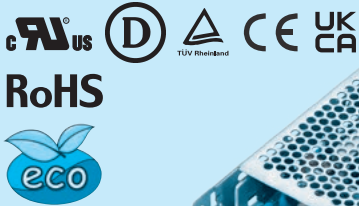

Example recommended EMI/EMC filter EAC-03-472



High voltage pulse noise type : EAP series
Low leakage current type : EAM series
* A higher current rating EMI/EMC filter may be recommended in view of the other devices that could be connected in parallel with the power supply.

- ① Series name
 - ② Single output
 - ③ Output wattage
 - ④ Universal input
 - ⑤ Output voltage
 - ⑥ Optional *1
 - C : with Coating
 - G : Low leakage current
 - J4 : EP(TE Connectivity) connector type
 - R□ : with Remote ON/OFF
 - S : with Chassis
 - SN : with Chassis & cover
 - T : Terminal block type
 - T4 : Push-in Terminal Block Type
 - T5 : UL508
 - U1 : Can be attached the external capacitor unit
- For option details, refer to instruction manual 7.1.

This power supply is manufactured by SMD technology. The stress to PCB like twisting or bending causes the defect of the unit, so handle the unit with care.
* Make sure necessary tests will be carried out on your end equipment with the power supply installed in accordance with any required EMC/EMI regulations.

MODEL	LHP150F-24-Y	LHP150F-30-Y	LHP150F-36-Y	LHP150F-42-Y	LHP150F-48-Y
MAX OUTPUT WATTAGE[W]	*2 151.2 (302.4)	150.0 (300.0)	151.2 (302.4)	151.2 (302.4)	153.6 (307.2)
DC OUTPUT	*2 24V6.3A (12.6A)	30V5.0A (10.0A)	36V4.2A (8.4A)	42V3.6A (7.2A)	48V3.2A (6.4A)

SPECIFICATIONS

	MODEL	LHP150F-24-Y	LHP150F-30-Y	LHP150F-36-Y	LHP150F-42-Y	LHP150F-48-Y	
INPUT	VOLTAGE[VAC]	85 - 264 1 φ (Refer to "Derating" and Instruction Manual 1.1) *8					
	CURRENT[A]	ACIN 100V	1.80typ				
		ACIN 230V	0.80typ				
	FREQUENCY[Hz]	50 / 60 (45 - 66)					
	EFFICIENCY[%]	ACIN 100V	90.0typ	90.0typ	90.5typ	90.5typ	91.0typ
		ACIN 230V	92.0typ	92.0typ	92.5typ	92.5typ	93.0typ
	POWER FACTOR (Io=100%)	ACIN 100V	0.99typ				
		ACIN 230V	0.93typ				
INRUSH CURRENT[A]	ACIN 100V	15typ (Io=100%) Ta=25°C at cold start					
	ACIN 230V	35typ (Io=100%) Ta=25°C at cold start					
LEAKAGE CURRENT[ma]	0.40/0.75max (ACIN 100 / 240V, 60Hz, Io=100%, According to IEC62368-1, and DEN-AN)						
OUTPUT	VOLTAGE[V]	24	30	36	42	48	
	CURRENT[A]	*2*8 6.3 (Peak 12.6)	5.0 (Peak 10.0)	4.2 (Peak 8.4)	3.6 (Peak 7.2)	3.2 (Peak 6.4)	
	LINE REGULATION[mV]	*4 96max	120max	144max	168max	192max	
	LOAD REGULATION[mV]	*4 150max	150max	180max	210max	240max	
	RIPPLE[mVp-p]	0 to +50°C	250max	280max	280max	280max	280max
		-10 to 0°C	310max	330max	330max	330max	330max
		Io=0 to 10%	310max	330max	330max	330max	330max
	RIPPLE NOISE[mVp-p]	0 to +50°C	290max	310max	310max	310max	310max
		-10 to 0°C	330max	360max	360max	360max	360max
		Io=0 to 10%	330max	360max	360max	360max	360max
	TEMPERATURE REGULATION[mV]	0 to +50°C	240max	300max	360max	420max	480max
		-10 to +50°C	290max	370max	450max	530max	600max
	DRIFT[mV]	*6 96max	120max	144max	168max	192max	
START-UP TIME[ms]	70typ (ACIN 100V, Io=100%)						
HOLD-UP TIME[ms]	20typ (ACIN 100V, Io=100%)						
OUTPUT VOLTAGE ADJUSTMENT RANGE[V]	22.80 to 26.40	28.50 to 33.00	34.20 to 39.60	39.90 to 46.20	45.60 to 52.80		
OUTPUT VOLTAGE SETTING[V]	24.00 to 24.96	30.00 to 31.20	36.00 to 37.44	42.00 to 43.68	48.00 to 49.92		
PROTECTION CIRCUIT AND OTHERS	OVERCURRENT PROTECTION	Works over 101% of rating and recovers automatically					
	OVERVOLTAGE PROTECTION [V]	27.6 to 33.6	34.5 to 42.0	41.4 to 50.4	48.3 to 58.8	55.2 to 67.2	
	OPERATING INDICATION	Not provided					
	REMOTE SENSING	Not provided					
	REMOTE ON/OFF (-R□)	Option (Refer to Instruction Manual 7.1)					
ISOLATION	INPUT-OUTPUT · RC	*7 AC3,000V 1minute Cutoff crrnt = 10mA, DC500V 100MΩ min (At Room Temperature)					
	INPUT-FG	AC2,000V 1minute Cutoff crrnt = 10mA, DC500V 100MΩ min (At Room Temperature)					
	OUTPUT-FG	*7 AC500V 1minute Cutoff crrnt = 25mA, DC500V 100MΩ min (At Room Temperature)					
	OUTPUT-RC	*7 AC100V 1minute Cutoff crrnt = 25mA, DC100V 100MΩ min (At Room Temperature)					
ENVIRONMENT	OPERATING TEMP., HUMID. AND ALTITUDE	*8 -10 to +70°C, 20 - 90%RH (Non condensing), 5,000m (16,500 feet) max, (EN62477-1 (OVC III):2,000m (6,600 feet) max)					
	STORAGE TEMP., HUMID. AND ALTITUDE	-20 to +75°C, 20 - 90%RH (Non condensing), 9,000m (30,000 feet) max					
	VIBRATION	10 - 55Hz 19.6m/s ² (2G) 3minutes period, 60minutes each along X, Y and Z axis					
	IMPACT	196.1m/s ² (20G), 11ms, once each X, Y and Z axis					
SAFETY AND NOISE REGULATIONS	AGENCY APPROVALS	UL62368-1, C-UL (equivalent to CAN / CSA-C22.2No.62368-1), EN62368-1, EN62477-1 (OVC III)					
	CONDUCTED NOISE	Complies with FCC-B, VCCI-B, CISPR32-B, EN55011-B, EN55032-B					
	HARMONIC ATTENUATOR	*9 Complies with IEC61000-3-2 (Class A)					
OTHERS	CASE SIZE/WEIGHT	75X27X160mm [2.95x1.07x6.30 inches] (WxHxD) / 320g max (with chassis & cover : 570g max)					
	COOLING METHOD	*8 Convection / Forced air (Requires external fan) (Refer to "Derating")					

*1 The listed optios may affect the published standard specifications. Please contact us for detailed product specifications and safety approvals.
*2 Peak loading for 10sec. And Duty 40% max, refer to Instruction Manual 6. In detail, () means peak current. There is a possibility that an internal device is damaged when the specification is exceeded.
*3 The current of input surge to a built-in EMI/EMS Filter (0.2ms or less) is excluded.
*4 In the case of dynamic fluctuations, the specifications may not be met.
*5 Measured by 20MHz oscilloscope or Ripple-Noise meter (Equivalent to KEISOKU-GIKEN : RM104). Please refer to the instruction manual 1.7.

*6 Drift is the change in DC output for an eight hour period after a half-hour warm-up at 25°C, with the input voltage held constant at the rated input/output.
*7 Applicable when Remote ON/OFF (optional) is added.
*8 Derating required. For use with DC input is Refer to Instruction Manual 1.1 and 7.1.
*9 Please contact us about another class.
* To meet the specification, do not operate overload conditon.
* Parallel operation is not possible.
* Sound noise may be generated by power supply in case of pulse load.
* Burst operation may occur when the load factor is 10% or less.

Block diagram

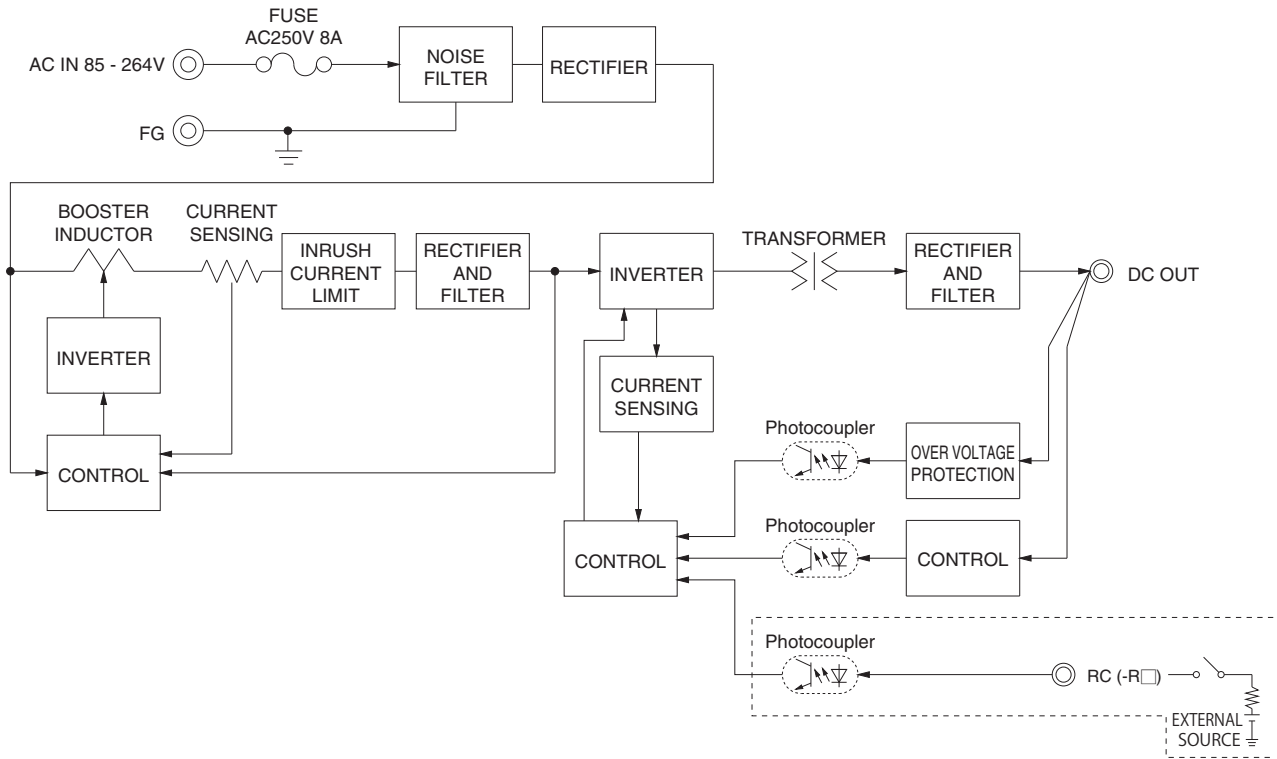

LHP

External view

※ External size of option is different from standard type.

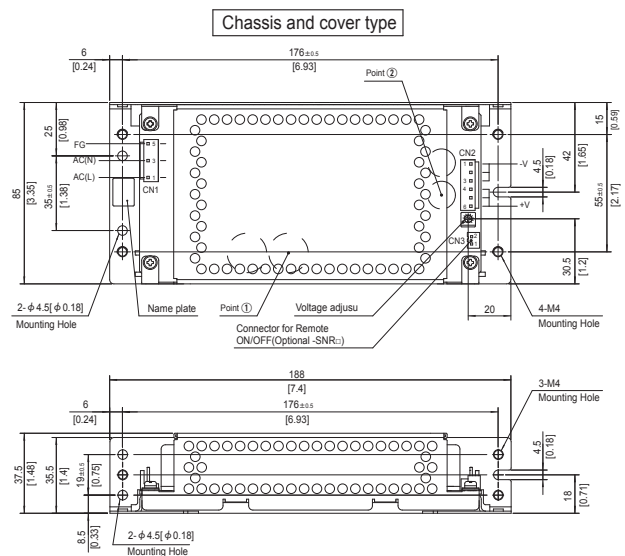
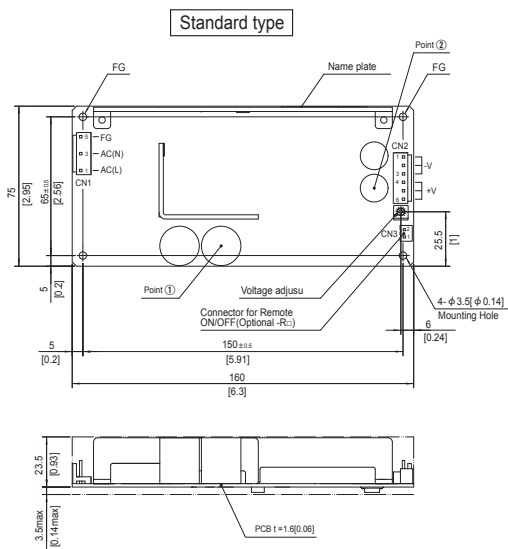

- ※ Use the spacer of 8mm [0.31] length or more for isolation. And do not use press-fitting bush.
- ※ The back side of the PCB when the power supply is assembled some SMDs. Be careful not to bump against the attached area by vibration.
- ※ Point ①, Point ② are thermometry points. Please refer to Instruction Manual 3. and 7.1.

< Mating connector and terminal >

I/O Connector	Mating connector	Terminal	Mfr.
CN1	B3P5-VH	VHR-5N	Chain SVH-21T-P1.1
			Loose BVH-21T-P1.1
CN2	B6P-VH	VHR-6N	Chain SVH-21T-P1.1
			Loose BVH-21T-P1.1

※ Option: -J4:EP (TE Connectivity) connector type.

Connector	Mating connector	Terminal	Mfr.
CN3	B2B-XH-A	XHP-2	Chain SXH-001T-P0.6
			Loose BXH-001T-P0.6

- ※ Dimensions in mm, []=inches
- ※ Tolerance : ±1 [±0.04]
- ※ Weight : 320g max (with chassis and cover : 570g max)
- ※ PCB Material / thickness : FR-4 / 1.6mm [0.06]
- ※ Optional chassis and cover material : Hot-dip galvanizing steel board
- ※ Mounting torque (Mounting hole of chassis) : 1.5N·m max

< Pin assignments >

Pin No.	Input
1	AC(L)
2	
3	AC(N)
4	
5	FG

Pin No.	Output
1 to 3	-V
4 to 6	+V

PIN No.	Contents
1	RC(+)
2	RC(-)

- ※ Pin No.2 and 4 is NC at CN1.
- ※ Keep drawing current per pin below 5A for CN2.

LHP300F

LH P 300 F -□□ -□

① ② ③ ④ ⑤ ⑥

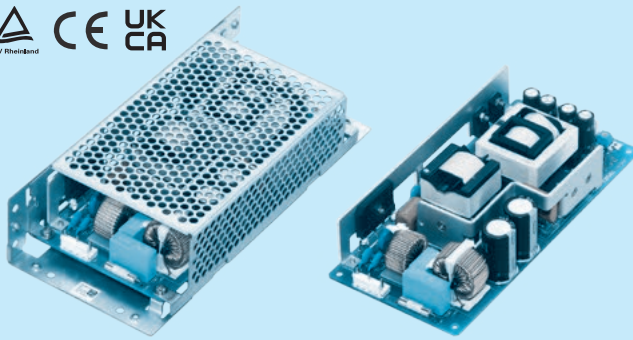
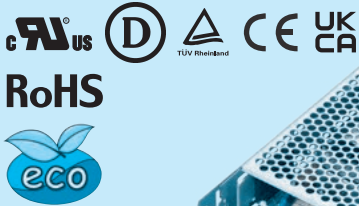

Example recommended EMI/EMC filter
EAC-06-472



High voltage pulse noise type : EAP series
Low leakage current type : EAM series
* A higher current rating EMI/EMC filter may be recommended in view of the other devices that could be connected in parallel with the power supply.

- ① Series name
 - ② Single output
 - ③ Output wattage
 - ④ Universal input
 - ⑤ Output voltage
 - ⑥ Optional *1
 - C : with Coating
 - G : Low leakage current
 - J4 : EP(TE Connectivity) connector type
 - J5 : 8pin type (Output connector)
 - R□ : with Remote ON/OFF
 - S : with Chassis
 - SN : with Chassis & cover
 - T : Terminal block type
 - T4 : Push-in Terminal Block Type
 - T5 : UL508
 - U1 : Can be attached the external capacitor unit
- For option details, refer to instruction manual 7.1.

This power supply is manufactured by SMD technology. The stress to PCB like twisting or bending causes the defect of the unit, so handle the unit with care.
*Make sure necessary tests will be carried out on your end equipment with the power supply installed in accordance with any required EMC/EMI regulations.

MODEL	LHP300F-24-Y	LHP300F-30-Y	LHP300F-36-Y	LHP300F-42-Y	LHP300F-48-Y
MAX OUTPUT WATTAGE[W]	*2 300.0 (600.0)	300.0 (600.0)	302.4 (604.8)	302.4 (604.8)	302.4 (604.8)
DC OUTPUT	*2 24V12.5A (25.0A)	30V10.0A (20.0A)	36V8.4A (16.8A)	42V7.2A (14.4A)	48V6.3A (12.6A)

SPECIFICATIONS

	MODEL	LHP300F-24-Y	LHP300F-30-Y	LHP300F-36-Y	LHP300F-42-Y	LHP300F-48-Y	
INPUT	VOLTAGE[VAC]	85 - 264 φ 1f (Refer to "Derating" and Instruction Manual 1.1) *8					
	CURRENT[A]	ACIN 100V	3.50typ				
		ACIN 230V	1.60typ				
	FREQUENCY[Hz]	50 / 60 (45 - 66)					
	EFFICIENCY[%]	ACIN 100V	91.5typ	91.5typ	91.5typ	91.5typ	92.0typ
		ACIN 230V	93.5typ	93.5typ	93.5typ	93.5typ	94.0typ
	POWER FACTOR (Io=100%)	ACIN 100V	0.99typ				
		ACIN 230V	0.93typ				
INRUSH CURRENT[A]	ACIN 100V	15typ (Io=100%) Ta=25°C at cold start					
	ACIN 230V	35typ (Io=100%) Ta=25°C at cold start					
LEAKAGE CURRENT[ma]	0.40/0.75max (ACIN 100 / 240V, 60Hz, Io=100%, According to IEC62368-1, and DEN-AN)						
OUTPUT	VOLTAGE[V]	24	30	36	42	48	
	CURRENT[A]	*2*8 12.5 (peak 25.0)	10.0 (peak 20.0)	8.4 (peak 16.8)	7.2 (peak 14.4)	6.3 (peak 12.6)	
	LINE REGULATION[mV]	*4 96max	120max	144max	168max	192max	
	LOAD REGULATION[mV]	*4 150max	195max	240max	240max	240max	
	RIPPLE [mVp-p]	0 to +50°C	300max	300max	300max	300max	300max
		-10 to 0°C	380max	420max	420max	420max	420max
		Io=0 to 10%	380max	420max	420max	420max	420max
	RIPPLE NOISE [mVp-p]	0 to +50°C	390max	390max	390max	390max	390max
		-10 to 0°C	500max	500max	500max	500max	500max
		Io=0 to 10%	500max	500max	500max	500max	500max
	TEMPERATURE REGULATION[mV]	0 to +50°C	240max	300max	360max	420max	480max
	-10 to +50°C	290max	370max	450max	530max	600max	
DRIFT[mV]	*6 96max	120max	144max	168max	192max		
START-UP TIME[ms]	70typ (ACIN 100V, Io=100%)						
HOLD-UP TIME[ms]	20typ (ACIN 100V, Io=100%)						
OUTPUT VOLTAGE ADJUSTMENT RANGE[V]	22.80 to 26.40	28.50 to 33.00	34.20 to 39.60	39.90 to 46.20	45.60 to 52.80		
OUTPUT VOLTAGE SETTING[V]	24.00 to 24.96	30.00 to 31.20	36.00 to 37.44	42.00 to 43.68	48.00 to 49.92		
PROTECTION CIRCUIT AND OTHERS	OVERCURRENT PROTECTION	Works over 101% of rating and recovers automatically					
	OVERVOLTAGE PROTECTION [V]	27.6 to 33.6	34.5 to 42.0	41.4 to 50.4	48.3 to 58.8	55.2 to 67.2	
	OPERATING INDICATION	Not provided					
	REMOTE SENSING	Not provided					
REMOTE ON/OFF (-R□)	Option (Refer to Instruction Manual 7.1)						
ISOLATION	INPUT-OUTPUT · RC	*7 AC3,000V 1minute Cutoff crrnt = 10mA, DC500V 100MΩ min (At Room Temperature)					
	INPUT-FG	AC2,000V 1minute Cutoff crrnt = 10mA, DC500V 100MΩ min (At Room Temperature)					
	OUTPUT-FG	*7 AC500V 1minute Cutoff crrnt = 25mA, DC500V 100MΩ min (At Room Temperature)					
	OUTPUT-RC	*7 AC100V 1minute Cutoff crrnt = 25mA, DC100V 100MΩ min (At Room Temperature)					
ENVIRONMENT	OPERATING TEMP., HUMID. AND ALTITUDE	*8 -10 to +70°C, 20 - 90%RH (Non condensing), 5,000m (16,500 feet) max, (EN62477-1 (OVC III):2,000m (6,600 feet) max)					
	STORAGE TEMP., HUMID. AND ALTITUDE	-20 to +75°C, 20 - 90%RH (Non condensing), 9,000m (30,000 feet) max					
	VIBRATION	10 - 55Hz 19.6m/s ² (2G) 3minutes period, 60minutes each along X, Y and Z axis					
SAFETY AND NOISE REGULATIONS	IMPACT	196.1m/s ² (20G), 11ms, once each X, Y and Z axis					
	AGENCY APPROVALS	UL62368-1, C-UL (equivalent to CAN / CSA-C22.2No.62368-1), EN62368-1, EN62477-1 (OVC III)					
	CONDUCTED NOISE	Complies with FCC-B, VCCI-B, CISPR32-B, EN55011-B, EN55032-B					
OTHERS	HARMONIC ATTENUATOR	*9 Complies with IEC61000-3-2 (Class A)					
	CASE SIZE/WEIGHT	84X37X180mm [3.31x1.46x7.09 inches] (WxHxD) / 580g max (with chassis & cover : 890g max)					
	COOLING METHOD	*8 Convection / Forced air (Requires external fan) (Refer to "Derating")					

*1 The listed optios may affect the published standard specifications. Please contact us for detailed product specifications and safety approvals.
*2 Peak loading for 10sec. And Duty 40% max, refer to Instruction Manual 6. In detail, () means peak current. There is a possibility that an internal device is damaged when the specification is exceeded.
*3 The current of input surge to a built-in EMI/EMS Filter (0.2ms or less) is excluded.
*4 In the case of dynamic fluctuations, the specifications may not be met.
*5 Measured by 20MHz oscilloscope or Ripple-Noise meter (Equivalent to KEISOKU-GIKEN : RM104). Please refer to the instruction manual 1.7.

*6 Drift is the change in DC output for an eight hour period after a half-hour warm-up at 25°C, with the input voltage held constant at the rated input/output.
*7 Applicable when Remote ON/OFF (optional) is added.
*8 Derating required. For use with DC input is Refer to Instruction Manual 1.1 and 7.1.
*9 Please contact us about another class.
* To meet the specification, do not operate overload condition.
* Parallel operation is not possible.
* Sound noise may be generated by power supply in case of pulse load.
* Burst operation may occur when the load factor is 10% or less.

Block diagram

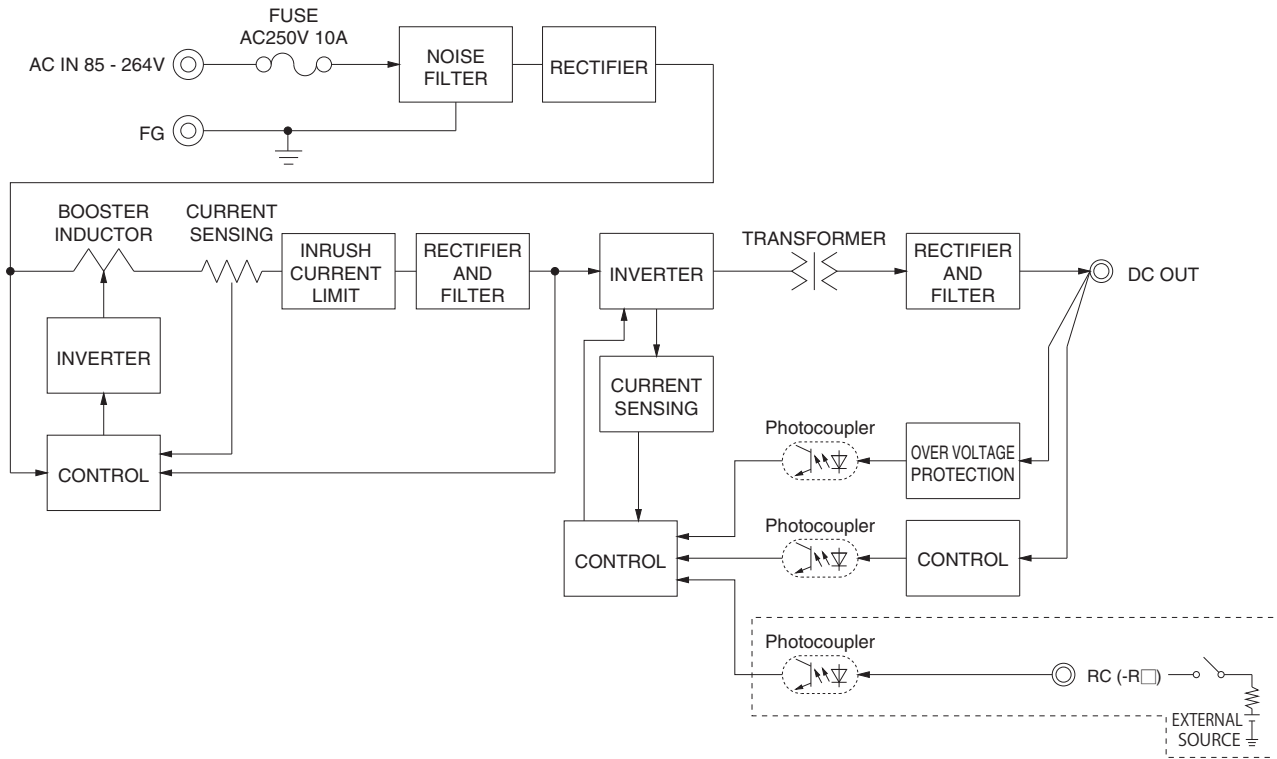

LHP

External view

※ External size of option is different from standard type.

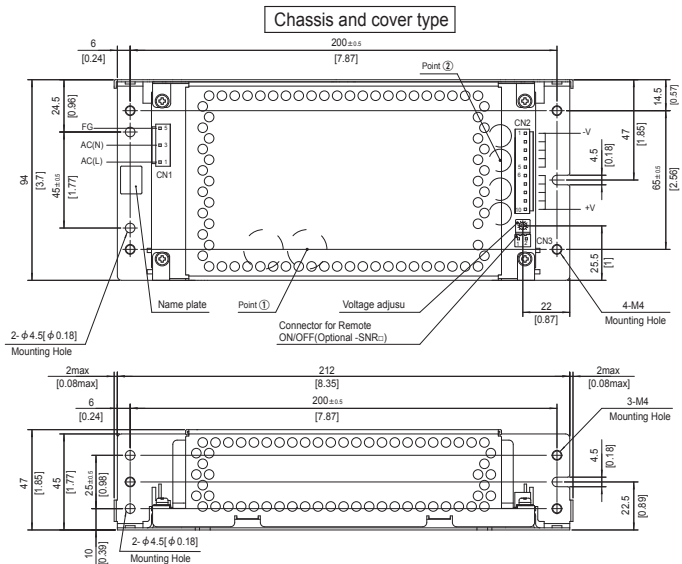
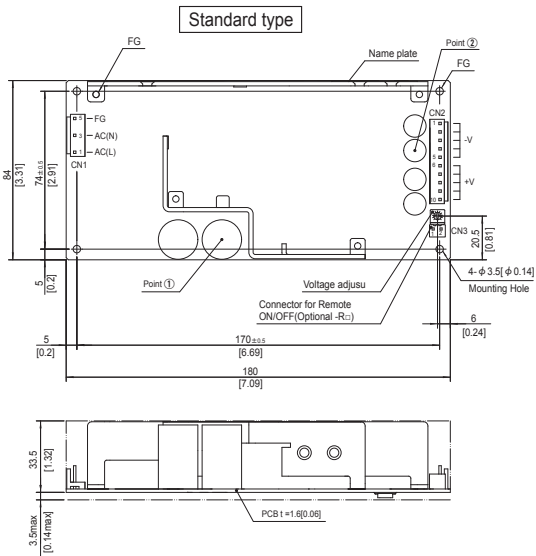

- ※ Use the spacer of 8mm [0.31] length or more for isolation. And do not use press-fitting bush.
- ※ The back side of PCB of the power supply is assembled some SMDs. Be careful not to bump against the attached area by vibration.
- ※ Point ①, Point ② are thermometry points. Please refer to Instruction Manual 3. and 7.1.

< Mating connector and terminal >

I/O Connector	Mating connector	Terminal	Mfr.
CN1	B3P5-VH	Chain	SVH-21T-P1.1
		Loose	BVH-21T-P1.1
CN2	B10P-VH	Chain	SVH-21T-P1.1
		Loose	BVH-21T-P1.1

- ※ Option:-J4:EP (TE Connectivity) connector type.
- ※ Option:-J5:Output connector as 8 pin type.

Connector	Mating connector	Terminal	Mfr.
CN3	B2B-XH-A	Chain	SXH-001T-P0.6
		Loose	BXH-001T-P0.6

- ※ Dimensions in mm, []=inches
- ※ Tolerance : ±1 [±0.04]
- ※ Weight : 580g max (with chassis and cover : 890g max)
- ※ PCB Material / thickness : FR-4 / 1.6mm [0.06]
- ※ Optional chassis and cover material : Hot-dip galvanizing steel board
- ※ Mounting torque (Mounting hole of chassis) : 1.5N·m max

< Pin assignments >

Pin No.	Input
1	AC(L)
2	
3	AC(N)
4	
5	FG

Pin No.	Output
1 to 5	-V
6 to 10	+V

PIN No.	Contents
1	RC(+)
2	RC(-)

- ※ Pin No.2 and 4 is NC at CN1.
- ※ Keep drawing current per pin below 5A for CN2.

Assembling and Installation Method

Installation method

■ This power supply is manufactured by SMD technology. Do not touch any SMD components on the unit. Be especially careful when handling.

■ If using a metal chassis, keep proper insulation between the component and metal chassis, use the spacer of 8mm or more between bottom of power supply and metal chassis.

If d_1 and/or d_2 are less than the value mentioned in right figure, insert an insulating sheet with reinforced insulation between the power supply unit and metal chassis.

The following distance is not satisfactory for cooling condition. Please refer to "Derating" and Instruction Manual 3 for cooling method.

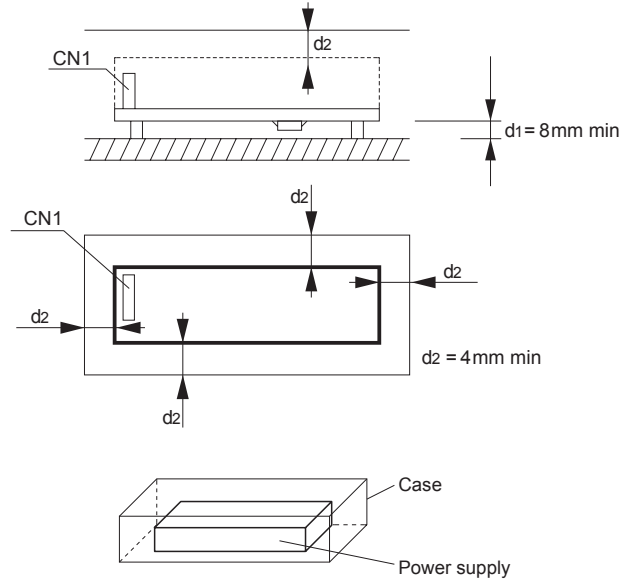

■ When used in a sealed case there is the possibility of insufficient cooling of the power supply – see right figure.

Please check and confirm that temperature of point ① and point ② stay below the limits given in the Instruction Manual 3.

■ Installation method shown right is possible.

■ In optional -SN, Method (F) is not available with convection cooling. If method (F) is used, use with forced air cooling or derate temperature / load. For more details, please contact us.

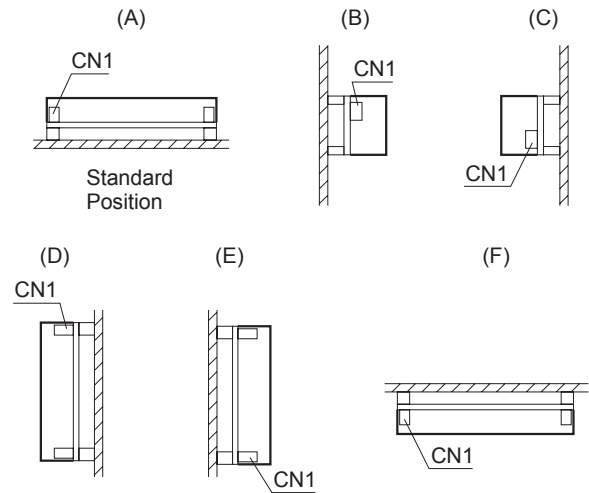

Mounting screw

■ The mounting screw should be $\phi 3\text{mm}$. The hatched area shows the allowance of metal parts for mounting.

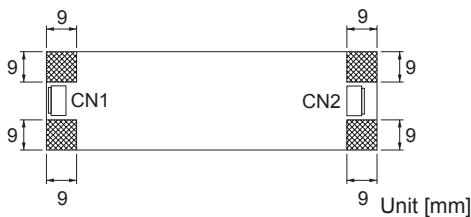

■ If mounting metallic fittings on the board surface, ensure there is no contact with components.

■ This product uses SMD technology. Please avoid the PCB installation method which includes the twisting stress or the bending stress.

Derating

● Derating curve for input voltage

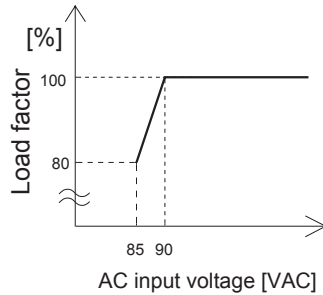

● LHP150F Ambient temperature derating curve (Reference value)

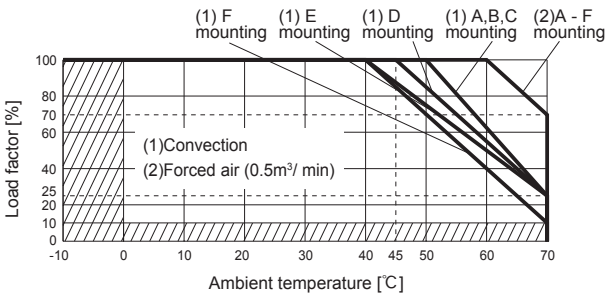

● LHP150F-□-SNY Ambient temperature derating curve (Reference value)

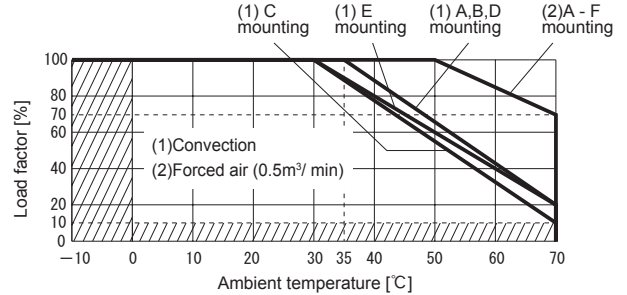

● LHP300F Ambient temperature derating curve (Reference value)

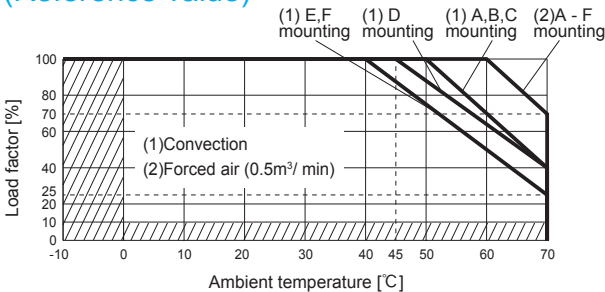

● LHP300F-□-SNY Ambient temperature derating curve (Reference value)

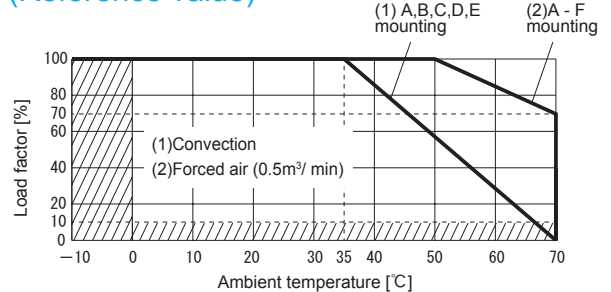

■ In the hatched area, the specification of Ripple, Ripple Noise is different from other area.

Instruction Manuals

◆ Please see catalog and instruction manual before you use.

Instruction Manuals <https://www.cosel.co.jp/redirect/catalog/en/LHP/>
 Before using our product <https://en.cosel.co.jp/technical/caution/index.html>

LHP



NOTICE



Basic Characteristics Data

Model	Circuit method	Switching frequency [kHz] *1 *2	Input current [A] *3	Inrush current protection	PCB/Pattern			Series / Parallel operation availability	
					Material	Single sided	Double sided	Series operation	Parallel operation
LHP150F	Active filter	20 to 160	1.8	Thermistor	FR-4	-	Yes	Yes	No
	LLC resonant converter	70 to 400							
LHP300F	Active filter	20 to 160	3.5	Thermistor	FR-4	-	Yes	Yes	No
	LLC resonant converter	40 to 210							

*1 The value changes depending on input and load.
 *2 At light load, burst operation is performed to reduce input power. The switching frequency is changed by using condition. Please contact us for more details.
 *3 The value of input current is at ACIN 100V and rated load.



LFP-series

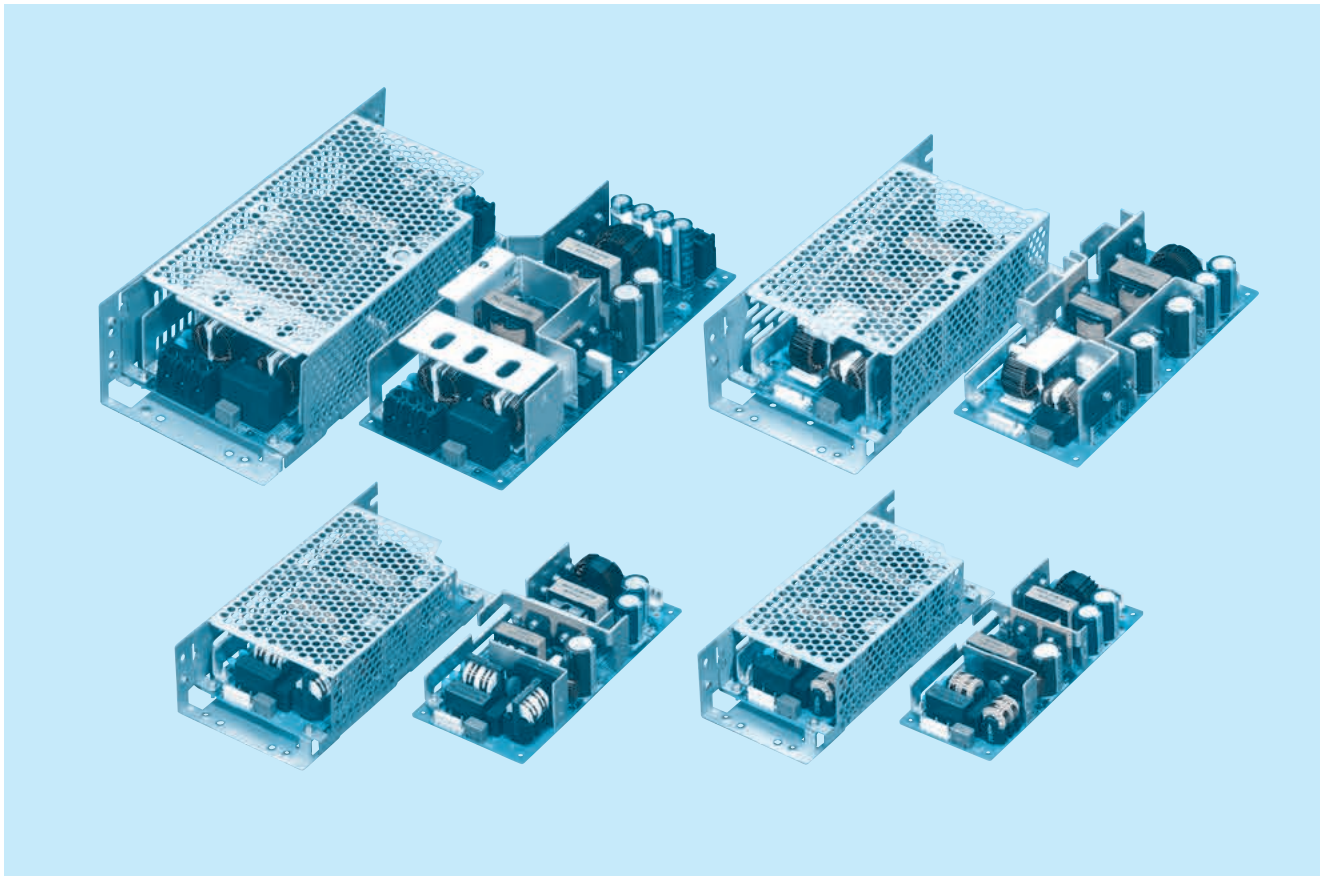

LFP

■ Feature

High power & peak power
 Small and compact PCB construction
 Built-in inrush current, overcurrent and overvoltage protection circuits
 Harmonic attenuator (Complies with IEC61000-3-2 class A)
 Universal input (AC85-264V)
 Power factor correction

■ Safety agency approvals

UL60950-1, C-UL(CSA60950-1), EN62368-1
 Complies with DEN-AN

■ EMI

Complies with FCC-B, CISPR22-B, EN55011-B, EN55022-B, VCCI-B

■ 5-year warranty (refer to Instruction Manual)

■ CE marking

Low Voltage Directive
 RoHS Directive

■ UKCA marking

Electrical Equipment Safety Regulations
 RoHS Regulations

■ EMS Compliance : EN61204-3, EN61000-6-2

EN61000-4-2
 EN61000-4-3
 EN61000-4-4
 EN61000-4-5
 EN61000-4-6
 EN61000-4-8
 EN61000-4-11

LFP100F

LF P 100 F -□ -□
 ① ② ③ ④ ⑤ ⑥

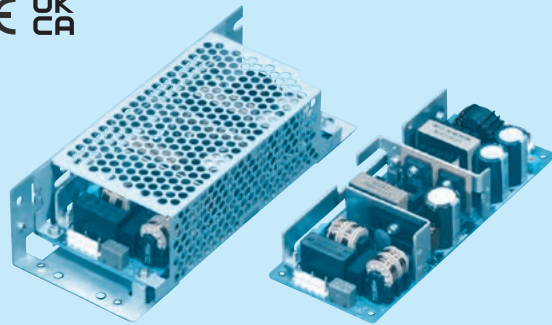

Example recommended EMI/EMC filter
NAC-04-472



High voltage pulse noise type : NAP series
 Low leakage current type : NAM series
 * A higher current rating EMI/EMC filter may be recommended in view of the other devices that could be connected in parallel with the power supply.

- ① Series name
- ② Single output
- ③ Output wattage
- ④ Universal input
- ⑤ Output voltage
- ⑥ Optional *1
- C : with Coating
- G : Low leakage current
- J1 : VH(J.S.T.)connector type
- R : with Remote ON/OFF
- R2 : with Remote ON/OFF
- S : with Chassis
- SN : with Chassis & cover

Please refer to Instruction manual 7.

This power supply is manufactured by SMD technology. The stress to P.C.B like twisting or bending causes the defect of the unit, so handle the unit with care.
 *Make sure necessary tests will be carried out on your end equipment with the power supply installed in accordance with any required EMC/EMI regulations.

MODEL	LFP100F-24-Y	LFP100F-36-Y	LFP100F-48-Y
MAX OUTPUT WATTAGE[W]	*2 103.2 (206.4)	100.8 (201.6)	100.8 (201.6)
DC OUTPUT	*2 24V 4.3A (8.6A)	36V 2.8A (5.6A)	48V 2.1A (4.2A)

SPECIFICATIONS

	MODEL	LFP100F-24-Y	LFP100F-36-Y	LFP100F-48-Y	
INPUT	VOLTAGE[V]	AC85 - 264 1 φ (Refer to "Derating", Instruction Manual 1 and 3) *5			
	CURRENT[A]	ACIN 100V	1.3typ (Io=100%)		
		ACIN 200V	0.7typ (Io=100%)		
	FREQUENCY[Hz]	50 / 60 (47 - 63)			
	EFFICIENCY[%]	ACIN 100V	84.0typ (Io=100%)		84.0typ (Io=100%)
		ACIN 200V	87.0typ (Io=100%)		87.0typ (Io=100%)
	POWER FACTOR	ACIN 100V	0.99typ (Io=100%)		
ACIN 200V		0.95typ (Io=100%)			
INRUSH CURRENT[A]	ACIN 100V	15typ (Io=100%) (At cold start) (Ta=25°C)			
	ACIN 200V	30typ (Io=100%) (At cold start) (Ta=25°C)			
LEAKAGE CURRENT[mA]	0.40 / 0.75max (ACIN 100V / 240V 60Hz, Io=100%, According to IEC62368-1 and DEN-AN)				
OUTPUT	VOLTAGE[V]	24	36	48	
	CURRENT[A]	*2 4.3 (Peak 8.6)	2.8 (Peak 5.6)	2.1 (Peak 4.2)	
	LINE REGULATION[mV]	*7 96max	144max	192max	
	LOAD REGULATION[mV]	*7 150max	240max	240max	
	RIPPLE[mVp-p]	*3 0 to +50°C	120max	150max	150max
		-10 - 0°C	160max	200max	200max
	RIPPLE NOISE[mVp-p]*3	0 to +50°C	150max	250max	250max
		-10 - 0°C	180max	300max	300max
	TEMPERATURE REGULATION[mV]	0 to +50°C	240max	360max	480max
		-10 to +50°C	290max	450max	600max
	DRIFT[mV]	*4 96max	144max	192max	
	START-UP TIME[ms]	350typ (ACIN 100V, Io=100%)			
	HOLD-UP TIME[ms]	20typ (ACIN 100V, Io=100%)			
OUTPUT VOLTAGE ADJUSTMENT RANGE[V]	21.60 to 27.50		32.40 to 39.60		
OUTPUT VOLTAGE SETTING[V]	24.00 to 24.96		36.00 to 37.44		
PROTECTION CIRCUIT AND OTHERS	OVERCURRENT PROTECTION	Works over 101% of rating and recovers automatically			
	OVERVOLTAGE PROTECTION[V]	27.60 to 33.60		41.40 to 50.40	
	OPERATING INDICATION	Not provided			
	REMOTE SENSING	Not provided			
	REMOTE ON/OFF	Option (Refer to Instruction Manual 6)			
ISOLATION	INPUT-OUTPUT-RC	*6 AC3,000V 1minute, Cutoff current = 10mA, DC500V 50MΩ min (At Room Temperature)			
	INPUT-FG	AC2,000V 1minute, Cutoff current = 10mA, DC500V 50MΩ min (At Room Temperature)			
	OUTPUT-RC-FG	*6 AC500V 1minute, Cutoff current = 25mA, DC500V 50MΩ min (At Room Temperature)			
	OUTPUT-RC	*6 AC100V 1minute, Cutoff current = 25mA, DC100V 10MΩ min (At Room Temperature)			
ENVIRONMENT	OPERATING TEMP., HUMID. AND ALTITUDE *5	-10 to +70°C, 20 - 90%RH (Non condensing) (Refer to "Derating", Instruction Manual 3), 3,000m (10,000feet) max			
	STORAGE TEMP., HUMID. AND ALTITUDE	-20 to +75°C, 20 - 90%RH (Non condensing), 9,000m (30,000feet) max			
	VIBRATION	10 - 55Hz, 19.6m/s ² (2G), 3minutes period, 60minutes each along X, Y and Z axis			
SAFETY AND NOISE REGULATIONS	IMPACT	196.1m/s ² (20G), 11ms, once each X, Y and Z axis			
	AGENCY APPROVALS (At only AC input)	UL60950-1, C-UL (CSA60950-1), EN62368-1 Complies with DEN-AN			
	CONDUCTED NOISE	Complies with FCC-B, VCCI-B, CISPR22-B, EN55011-B, EN55022-B			
OTHERS	HARMONIC ATTENUATOR	Complies with IEC61000-3-2 (Class A) *8			
	CASE SIZE/WEIGHT	62 X 33 X 155mm [2.44 X 1.30 X 6.10 inches] (W X H X D) / 290g max (with chassis & cover : 480g max)			
	COOLING METHOD	Convection (Refer to "Derating", Instruction Manual 3) *5			

*1 Specification is changed at option, refer to Instruction Manual.
 *2 Peak loading for 10sec. And Duty 40% max, refer to Instruction Manual 6. In detail.
 () means peak current. There is a possibility that an internal device is damaged when the specification is exceeded.
 *3 This is the value that measured on measuring board with capacitor of 22 μF at 150mm from output terminal.

Measured by 20MHz oscilloscope or Ripple-Noise meter (Equivalent to KEISOKU-GIKEN: RM103).
 *4 Drift is the change in DC output for an eight hour period after a half-hour warm-up at 25°C, with the input voltage held constant at the rated input/output.
 *5 Derating is required.
 *6 Applicable when remote control (optional) is added.

*7 Please contact us about dynamic load and input response.
 *8 Please contact us about another class.
 * To meet the specifications. Do not operate over-loaded condition.
 * Parallel operation is not possible.
 * Derating is required when operated with chassis and cover.
 * Sound noise may be generated by power supply in case of pulse load.

Block diagram

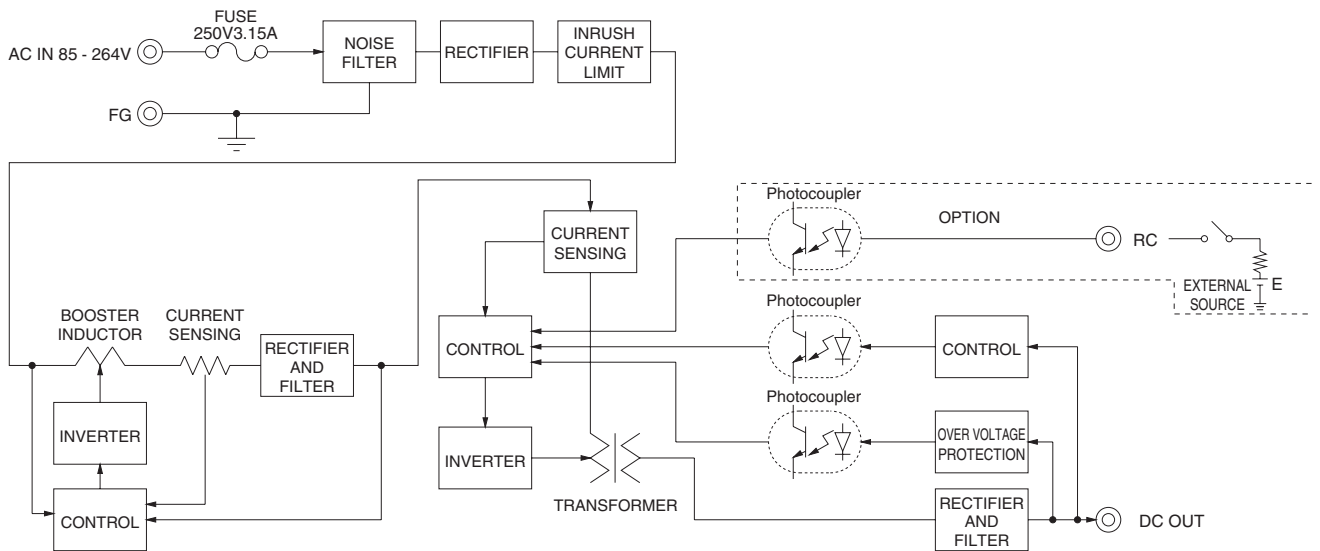

External view

※ External size of option is different from standard model.

Standard type

Chassis and cover type

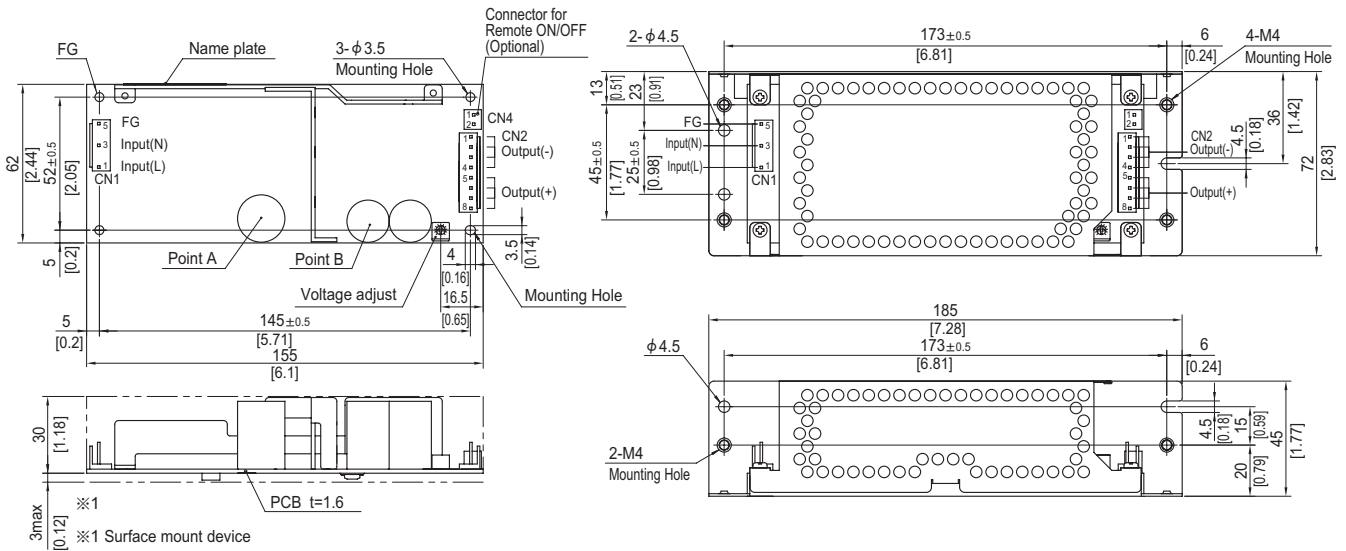

- ※ 4 Mounting holes are existing.
- ※ The back side of P.C.B. of the power supply is assembled some SMDs.
Be attention not to bump against the attached area by vibration.
- ※ Use the spacer of 8mm length or more regarding insulation.
And do not use press-fitting bush.
- ※ Point A, Point B are thermometry points. Please refer to Instruction Manual 3.

I/O Connector	Mating connector	Terminal
CN1	1-1123724-3	Chain 1123721-1 Loose 1318912-1
CN2	1-1123723-8	Chain 1123721-1 Loose 1318912-1

(Mfr:Tyco Electronics)

- ※ I/O Connector is Mfr. Tyco Electronics
- ※ Option:-J1:VH(J.S.T) connector type.

<PIN CONNECTION>

CN1		CN2	
Pin No.	Input	Pin No.	Output
1	AC(L)	1 to 4	-V
2		5 to 8	+V
3	AC(N)		
4			
5	FG		

※ Keep drawing current per pin below 5A for CN2.

- ※ Tolerance : ± 1 [± 0.04]
- ※ Weight : 290g max (with chassis & cover : 480g max)
- ※ PCB material : CEM3
- ※ Optional chassis and cover material : Electric galvanizing steel board.
- ※ Dimensions in mm, []=inches
- ※ Mounting torque (Mounting hole of chassis) : $1.5N \cdot m$ (16kgf · cm) max

Connector type

CN4 Option (Mfr:J.S.T)	
PIN No.	Contents
1	RC(+)
2	RC(-)

Barrier strip type

Model B2B-XH-A
Mating Connector (Terminal)
XHP-2
(BXH-001T-P0.6
or SXH-001T-P0.6)

LFP150F

① LF ② P ③ 150 ④ F ⑤ -□ ⑥ -□

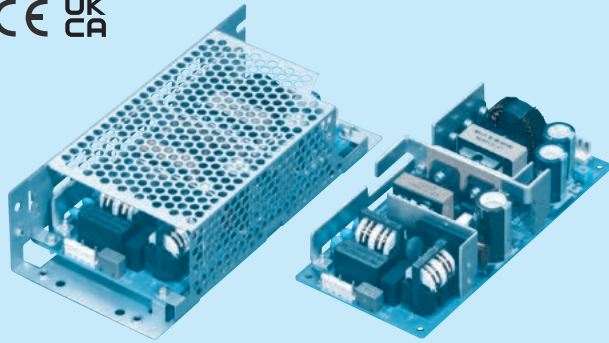

Example recommended EMI/EMC filter
NAC-04-472



High voltage pulse noise type : NAP series
Low leakage current type : NAM series
* A higher current rating EMI/EMC filter may be recommended in view of the other devices that could be connected in parallel with the power supply.

- ① Series name
- ② Single output
- ③ Output wattage
- ④ Universal input
- ⑤ Output voltage
- ⑥ Optional *1
- C : with Coating
- G : Low leakage current
- J1 : VH(J.S.T.)connector type
- R : with Remote ON/OFF
- R2 : with Remote ON/OFF
- S : with Chassis
- SN : with Chassis & cover

Please refer to Instruction manual 7.

This power supply is manufactured by SMD technology. The stress to P.C.B like twisting or bending causes the defect of the unit, so handle the unit with care.
* Make sure necessary tests will be carried out on your end equipment with the power supply installed in accordance with any required EMC/EMI regulations.

MODEL	LFP150F-24-Y	LFP150F-36-Y	LFP150F-48-Y
MAX OUTPUT WATTAGE[W]	*2 151.2 (302.4)	151.2 (302.4)	153.6 (307.2)
DC OUTPUT	*2 24V 6.3A (12.6A)	36V 4.2A (8.4A)	48V 3.2A (6.4A)

SPECIFICATIONS

	MODEL	LFP150F-24-Y	LFP150F-36-Y	LFP150F-48-Y	
INPUT	VOLTAGE[V]	AC85 - 264 1 φ (Refer to "Derating", Instruction Manual 1 and 3) *5			
	CURRENT[A]	ACIN 100V	2.0typ (Io=100%)		
		ACIN 200V	1.0typ (Io=100%)		
	FREQUENCY[Hz]	50 / 60 (47 - 63)			
	EFFICIENCY[%]	ACIN 100V	85.5typ (Io=100%)		85.5typ (Io=100%)
		ACIN 200V	88.0typ (Io=100%)		88.0typ (Io=100%)
	POWER FACTOR	ACIN 100V	0.99typ (Io=100%)		
ACIN 200V		0.95typ (Io=100%)			
INRUSH CURRENT[A]	ACIN 100V	15typ (Io=100%) (At cold start) (Ta=25°C)			
	ACIN 200V	30typ (Io=100%) (At cold start) (Ta=25°C)			
LEAKAGE CURRENT[mA]	0.40 / 0.75max (ACIN 100V / 240V 60Hz, Io=100%, According to IEC62368-1 and DEN-AN)				
OUTPUT	VOLTAGE[V]	24	36	48	
	CURRENT[A]	*2 6.3 (Peak 12.6)	4.2 (Peak 8.4)	3.2 (Peak 6.4)	
	LINE REGULATION[mV]	*7 96max	144max	192max	
	LOAD REGULATION[mV]	*7 150max	240max	240max	
	RIPPLE[mVp-p]	*3 0 to +50°C	120max	150max	150max
		-10 - 0°C	160max	200max	200max
	RIPPLE NOISE[mVp-p]*3	0 to +50°C	150max	250max	250max
		-10 - 0°C	180max	300max	300max
	TEMPERATURE REGULATION[mV]	0 to +50°C	240max	360max	480max
		-10 to +50°C	290max	450max	600max
	DRIFT[mV]	*4 96max	144max	192max	
	START-UP TIME[ms]	350typ (ACIN 100V, Io=100%)			
	HOLD-UP TIME[ms]	20typ (ACIN 100V, Io=100%)			
	OUTPUT VOLTAGE ADJUSTMENT RANGE[V]	21.60 to 27.50		32.40 to 39.60	39.60 to 52.80
OUTPUT VOLTAGE SETTING[V]	24.00 to 24.96		36.00 to 37.44	48.00 to 49.92	
OVERCURRENT PROTECTION	Works over 101% of rating and recovers automatically				
OVERVOLTAGE PROTECTION[V]	27.60 to 33.60		41.40 to 50.40	55.20 to 67.20	
OPERATING INDICATION	Not provided				
REMOTE SENSING	Not provided				
REMOTE ON/OFF	Option (Refer to Instruction Manual 6)				
ISOLATION	INPUT-OUTPUT-RC	*6 AC3,000V 1minute, Cutoff current = 10mA, DC500V 50MΩ min (At Room Temperature)			
	INPUT-FG	AC2,000V 1minute, Cutoff current = 10mA, DC500V 50MΩ min (At Room Temperature)			
	OUTPUT-RC-FG	*6 AC500V 1minute, Cutoff current = 25mA, DC500V 50MΩ min (At Room Temperature)			
	OUTPUT-RC	*6 AC100V 1minute, Cutoff current = 25mA, DC100V 10MΩ min (At Room Temperature)			
ENVIRONMENT	OPERATING TEMP., HUMID. AND ALTITUDE	*5 -10 to +70°C, 20 - 90%RH (Non condensing) (Refer to "Derating", Instruction Manual 3), 3,000m (10,000feet) max			
	STORAGE TEMP., HUMID. AND ALTITUDE	-20 to +75°C, 20 - 90%RH (Non condensing), 9,000m (30,000feet) max			
	VIBRATION	10 - 55Hz, 19.6m/s ² (2G), 3minutes period, 60minutes each along X, Y and Z axis			
IMPACT	196.1m/s ² (20G), 11ms, once each X, Y and Z axis				
SAFETY AND NOISE REGULATIONS	AGENCY APPROVALS (At only AC input)	UL60950-1, C-UL (CSA60950-1), EN62368-1 Complies with DEN-AN			
	CONDUCTED NOISE	Complies with FCC-B, VCCI-B, CISPR22-B, EN55011-B, EN55022-B			
	HARMONIC ATTENUATOR	Complies with IEC61000-3-2 (Class A) *8			
OTHERS	CASE SIZE/WEIGHT	75 X 36.5 X 160mm [2.95 X 1.44 X 6.30 inches] (W X H X D) / 380g max (with chassis & cover : 610g max)			
	COOLING METHOD	Convection (Refer to "Derating", Instruction Manual 3) *5			

*1 Specification is changed at option, refer to Instruction Manual.

*2 Peak loading for 10sec. And Duty 40% max, refer to Instruction Manual 6. In detail.

() means peak current. There is a possibility that an internal device is damaged when the specification is exceeded.

*3 This is the value that measured on measuring board with capacitor of 22 μF at 150mm from output terminal.

Measured by 20MHz oscilloscope or Ripple-Noise meter (Equivalent to KEISOKU-GIKEN: RM103).

*4 Drift is the change in DC output for an eight hour period after a half-hour warm-up at 25°C, with the input voltage held constant at the rated input/output.

*5 Derating is required.

*6 Applicable when remote control (optional) is added.

*7 Please contact us about dynamic load and input response.

*8 Please contact us about another class.

* To meet the specifications. Do not operate over-loaded condition.

* Parallel operation is not possible.

* Derating is required when operated with chassis and cover.

* Sound noise may be generated by power supply in case of pulse load.

Block diagram

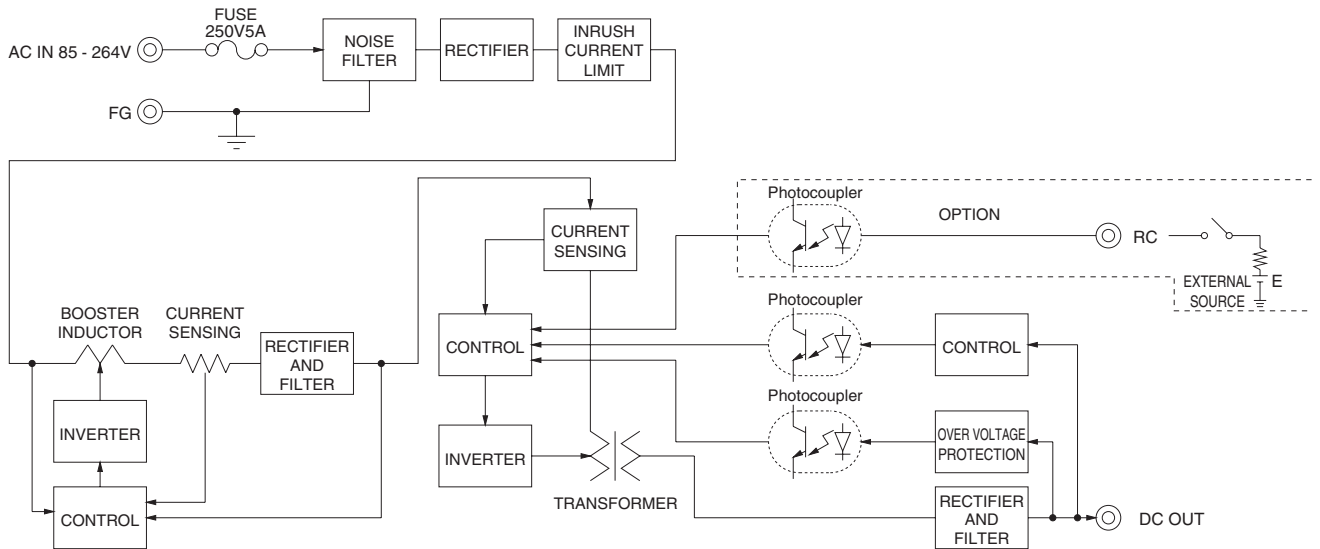

LFP

External view

※ External size of option is different from standard model.

Standard type

Chassis and cover type

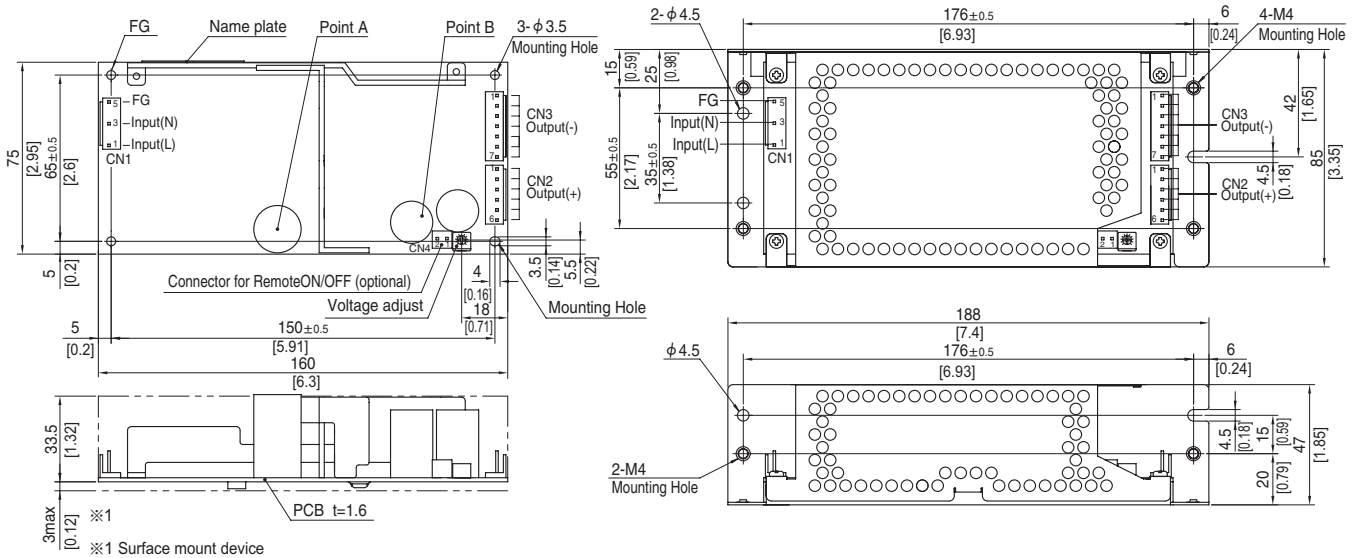

- ※ 4 Mounting holes are existing.
- ※ The back side of P.C.B. of the power supply is assembled some SMDs.
- Be attention not to bump against the attached area by vibration.
- ※ Use the spacer of 8mm length or more regarding insulation.
- And do not use press-fitting bush.
- ※ Point A, Point B are thermometry points. Please refer to Instruction Manual 3.

I/O Connector	Mating connector	Terminal
CN1	1-1123724-3	Chain 1123721-1
		Loose 1318912-1
CN2	1-1123723-6	Chain 1123721-1
		Loose 1318912-1
CN3	1-1123723-7	Chain 1123721-1
		Loose 1318912-1

(Mfr:Tyco Electronics)

- ※ I/O Connector is Mfr. Tyco Electronics
- ※ Option:-J1:VH(J.S.T) connector type.

<PIN CONNECTION>

CN1		CN2		CN3	
Pin No.	Input	Pin No.	Output	Pin No.	Output
1	AC(L)	1 to 6	+V	1 to 7	-V
2					
3	AC(N)				
4					
5	FG				

※ Keep drawing current per pin below 5A for CN2,CN3.

- ※ Tolerance : ± 1 [± 0.04]
- ※ Weight : 380g max (with chassis & cover : 610g max)
- ※ PCB material : CEM3
- ※ Optional chassis and cover material : Electric galvanizing steel board.
- ※ Dimensions in mm, []=inches
- ※ Mounting torque (Mounting hole of chassis) : $1.5N \cdot m$ (16kgf · cm) max

Connector type

CN4 Option (Mfr:J.S.T)

PIN No.	Contents
1	RC(+)
2	RC(-)

Barrier strip type

Model B2B-XH-A
Mating Connector (Terminal)
XHP-2
(BXH-001T-P0.6
or SXH-001T-P0.6)

LFP240F

LF P 240 F -□ -□
 ① ② ③ ④ ⑤ ⑥

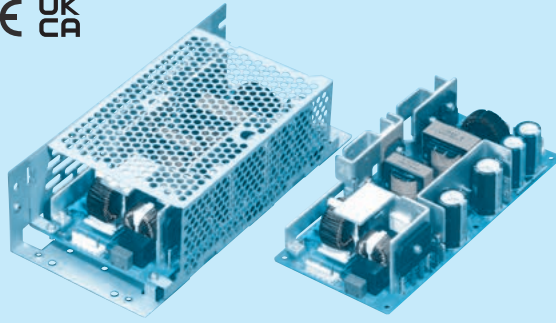

Example recommended EMI/EMC filter
NAC-06-472



High voltage pulse noise type : NAP series
 Low leakage current type : NAM series
 * A higher current rating EMI/EMC filter may be recommended in view of the other devices that could be connected in parallel with the power supply.

- ① Series name
- ② Single output
- ③ Output wattage
- ④ Universal input
- ⑤ Output voltage
- ⑥ Optional *1
- C : with Coating
- G : Low leakage current
- J1 : VH(J.S.T.)connector type
- R : with Remote ON/OFF
- R2 : with Remote ON/OFF
- S : with Chassis
- SN : with Chassis & cover
- T : Vertical terminal block
- U1 : Can be attached the external capacitor unit

Please refer to Instruction manual 7.

This power supply is manufactured by SMD technology. The stress to P.C.B like twisting or bending causes the defect of the unit, so handle the unit with care.
 * Make sure necessary tests will be carried out on your end equipment with the power supply installed in accordance with any required EMC/EMI regulations.

MODEL	LFP240F-24-Y	LFP240F-30-Y	LFP240F-36-Y	LFP240F-48-Y
MAX OUTPUT WATTAGE[W]	300 (480)	300 (480)	302.4 (482.4)	302.4 (480)
DC OUTPUT	Convection	30V 8A (16A)	36V 6.7A (13.4A)	48V 5A (10A)
	Forced air	24V 12.5A (20A)	30V 10A (16A)	36V 8.4A (13.4A)

SPECIFICATIONS

	MODEL	LFP240F-24-Y	LFP240F-30-Y	LFP240F-36-Y	LFP240F-48-Y	
INPUT	VOLTAGE[V]	AC85 - 264 1 φ (Refer to "Derating", Instruction Manual 1 and 3) *5				
	CURRENT[A]	ACIN 100V	3.6typ (Io=100%)			
		ACIN 200V	1.8typ (Io=100%)			
	FREQUENCY[Hz]	50 / 60 (47 - 63)				
	EFFICIENCY[%]	ACIN 100V	86.0typ (Io=100%)			
		ACIN 200V	88.5typ (Io=100%)			
	POWER FACTOR	ACIN 100V	0.99typ (Io=100%)			
		ACIN 200V	0.95typ (Io=100%)			
	INRUSH CURRENT[A]	ACIN 100V	15 / 30typ (Io=100%) (Primary inrush current /Secondary inrush current) (More than 3 sec. to re-start)			
		ACIN 200V	30 / 30typ (Io=100%) (Primary inrush current /Secondary inrush current) (More than 3 sec. to re-start)			
LEAKAGE CURRENT[ma]	0.40 / 0.75max (ACIN 100V / 240V 60Hz, Io=100%, According to IEC62368-1 and DEN-AN)					
OUTPUT	VOLTAGE[V]	24	30	36	48	
	CURRENT[A]	Convection *2	10 (Peak 20)	8 (Peak 16)	6.7 (Peak 13.4)	5 (Peak 10)
		Forced air *2	12.5 (Peak 20)	10 (Peak 16)	8.4 (Peak 13.4)	6.3 (Peak 10)
	LINE REGULATION[mV]	*7	96max	144max	144max	192max
	LOAD REGULATION[mV]	*7	150max	240max	240max	240max
	RIPPLE [mVp-p] *3	0 to +50°C	120max	150max	150max	150max
		-10 - 0°C	160max	200max	200max	200max
	RIPPLE NOISE [mVp-p] *3	0 to +50°C	150max	250max	250max	250max
		-10 - 0°C	180max	300max	300max	300max
	TEMPERATURE REGULATION [mV]	0 to +50°C	240max	360max	360max	480max
		-10 to +50°C	290max	450max	450max	600max
	DRIFT [mV]	*4	96max	144max	144max	192max
	START-UP TIME [ms]	350typ (ACIN 100V, Io=100%)				
	HOLD-UP TIME [ms]	*9 20typ (ACIN 100V, Io=100%)				
	OUTPUT VOLTAGE ADJUSTMENT RANGE [V]	21.60 to 27.50				
OUTPUT VOLTAGE SETTING [V]	24.00 to 24.96		30.00 to 31.20		32.40 to 39.60	
PROTECTION CIRCUIT AND OTHERS	OVERCURRENT PROTECTION	Works over 101% of rating and recovers automatically				
	OVERVOLTAGE PROTECTION [V]	27.60 to 33.60	34.50 to 42.00	41.40 to 50.40	55.20 to 67.20	
	OPERATING INDICATION	Not provided				
	REMOTE SENSING	Not provided				
	REMOTE ON/OFF	Option (Refer to Instruction Manual 6)				
ISOLATION	INPUT-OUTPUT-RC	*6 AC3,000V 1minute, Cutoff current = 10mA, DC500V 50MΩ min (At Room Temperature)				
	INPUT-FG	AC2,000V 1minute, Cutoff current = 10mA, DC500V 50MΩ min (At Room Temperature)				
	OUTPUT-RC-FG	*6 AC500V 1minute, Cutoff current = 25mA, DC500V 50MΩ min (At Room Temperature)				
	OUTPUT-RC	*6 AC100V 1minute, Cutoff current = 25mA, DC100V 10MΩ min (At Room Temperature)				
ENVIRONMENT	OPERATING TEMP., HUMID. AND ALTITUDE *5	-10 to +70°C, 20 - 90%RH (Non condensing) (Refer to "Derating", Instruction Manual 3), 3,000m (10,000feet) max				
	STORAGE TEMP., HUMID. AND ALTITUDE	-20 to +75°C, 20 - 90%RH (Non condensing), 9,000m (30,000feet) max				
	VIBRATION	10 - 55Hz, 19.6m/s ² (2G), 3minutes period, 60minutes each along X, Y and Z axis				
SAFETY AND NOISE REGULATIONS	IMPACT	196.1m/s ² (20G), 11ms, once each X, Y and Z axis				
	AGENCY APPROVALS (At only AC input)	UL60950-1, C-UL (CSA60950-1), EN62368-1 Complies with DEN-AN				
	CONDUCTED NOISE	Complies with FCC-B, VCCI-B, CISPR22-B, EN55011-B, EN55022-B				
OTHERS	HARMONIC ATTENUATOR	Complies with IEC61000-3-2 (Class A) *8				
	CASE SIZE/WEIGHT	84 X 46 X 180mm [3.31 X 1.81 X 7.09 inches] (W X H X D) / 540g max (with chassis & cover : 860g max)				
	COOLING METHOD	Convection / Forced air (Refer to "Derating", Instruction Manual 3) *5				

*1 Specification is changed at option, refer to Instruction Manual.
 *2 Peak loading for 10sec. And Duty 40% max, refer to Instruction Manual 6. In detail.
 () means peak current. There is a possibility that an internal device is damaged when the specification is exceeded.
 *3 This is the value that measured on measuring board with capacitor of 22 μF at 150mm from output terminal.
 *4 Measured by 20MHz oscilloscope or Ripple-Noise meter (Equivalent to KEISOKU-GIKEN: RM103).
 *5 Drift is the change in DC output for an eight hour period after a half-hour warm-up at 25°C, with the input voltage held constant at the rated input/output.
 *6 Derating is required.
 *7 Applicable when remote control (optional) is added.
 *8 Please contact us about dynamic load and input response.
 *9 Please contact us about another class.
 *10 By attaching an external capacitor unit, it is possible to extend the hold-up time.
 *11 To meet the specifications. Do not operate over-loaded condition.
 *12 Parallel operation is not possible.
 *13 Derating is required when operated with chassis and cover.
 *14 Sound noise may be generated by power supply in case of pulse load.

Block diagram

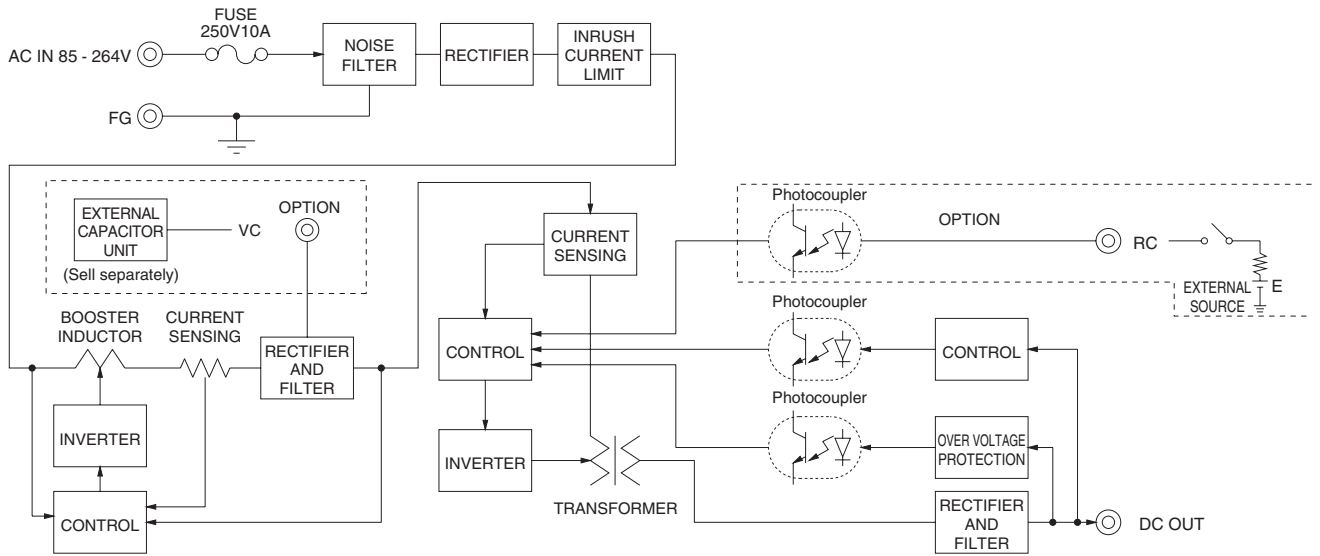

External view

※ External size of option is different from standard model.

Standard type

Chassis and cover type

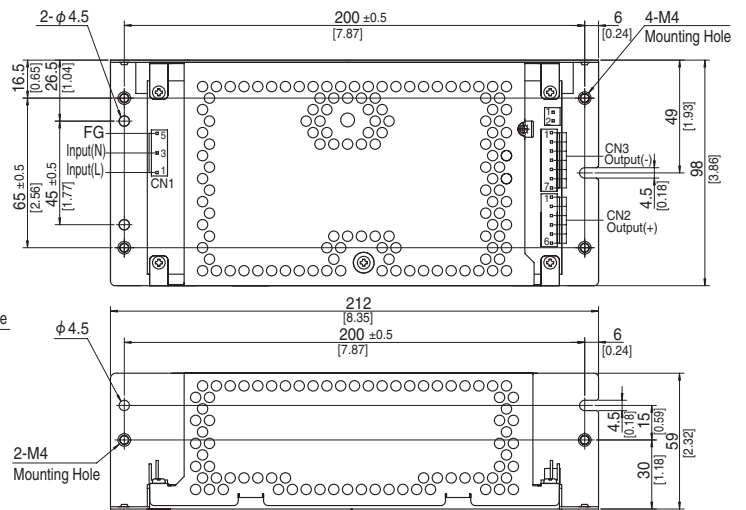
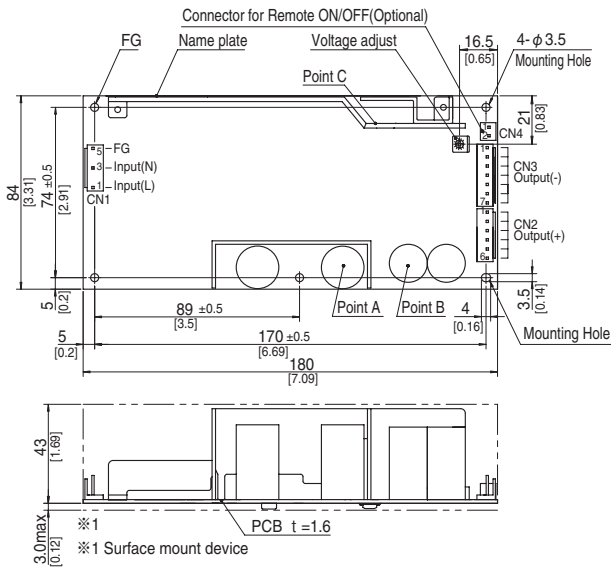

- ※ 5 Mounting holes are existing.
- ※ The back side of P.C.B. of the power supply is assembled some SMDs.
Be attention not to bump against the attached area by vibration.
- ※ Use the spacer of 8mm length or more regarding insulation.
And do not use press-fitting bush.
- ※ Point A, Point B, Point C are thermometry points. Please refer to Instruction Manual 3.

I/O Connector	Mating connector	Terminal
CN1	1-1123724-3	Chain 1123721-1
		Loose 1318912-1
CN2	1-1123723-6	Chain 1123721-1
		Loose 1318912-1
CN3	1-1123723-7	Chain 1123721-1
		Loose 1318912-1

(Mfr:Tyco Electronics)

- ※ I/O Connector is Mfr. Tyco Electronics
- ※ Option:-J1:VH(J.S.T) connector type.

<PIN CONNECTION>

CN1		CN2		CN3	
Pin No.	Input	Pin No.	Output	Pin No.	Output
1	AC(L)	1 to 6	+V	1 to 7	-V
2					
3	AC(N)				
4					
5	FG				

※ Keep drawing current per pin below 5A for CN2,CN3.

- ※ Tolerance : ± 1 [± 0.04]
- ※ Weight : 540g max (with chassis & cover : 860g max)
- ※ PCB material : CEM3
- ※ Optional chassis and cover material : Electric galvanizing steel board.
- ※ Dimensions in mm, [] =inches
- ※ Mounting torque (Mounting hole of chassis) : $1.5N \cdot m$ (16kgf · cm) max

Connector type

CN4 Option (Mfr:J.S.T)

PIN No.	Contents
1	RC(+)
2	RC(-)

Barrier strip type

Model B2B-XH-A
Mating Connector (Terminal)
XHP-2
(BXH-001T-P0.6
or SXH-001T-P0.6)

LFP300F

① LF ② P ③ 300 ④ F ⑤ -□ ⑥ -□

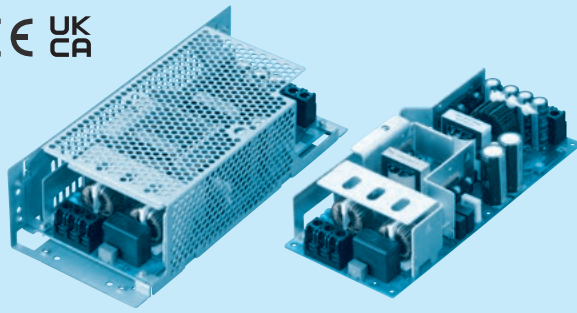
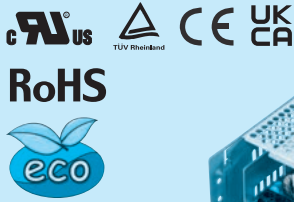

Example recommended EMI/EMC filter
NAC-06-472



High voltage pulse noise type : NAP series
Low leakage current type : NAM series
* A higher current rating EMI/EMC filter may be recommended in view of the other devices that could be connected in parallel with the power supply.

- ① Series name
- ② Single output
- ③ Output wattage
- ④ Universal input
- ⑤ Output voltage
- ⑥ Optional *1
- C : with Coating
- G : Low leakage current
- J : EP (Tyco Electronics) connector type
- J1 : VH (J.S.T.) connector type
- R : with Remote ON/OFF
- R2 : with Remote ON/OFF S
- S : with Chassis
- SN : with Chassis & cover
- SNF : with Chassis & cover & fan (Only 24V)
- T1 : Horizontal terminal block
- U1 : Can be attached the external capacitor unit

This power supply is manufactured by SMD technology. The stress to P.C.B like twisting or bending causes the defect of the unit, so handle the unit with care.
* Make sure necessary tests will be carried out on your end equipment with the power supply installed in accordance with any required EMC/EMI regulations.

Please refer to Instruction manual 7.

MODEL	LFP300F-24-TY	LFP300F-30-TY	LFP300F-36-TY	LFP300F-48-TY
MAX OUTPUT WATTAGE[W]	360 (600)	360 (600)	360 (604.8)	360 (604.8)
DC OUTPUT	Convection	24V 12.5A (25A)	30V 10A (20A)	48V 6.3A (12.6A)
	Forced air	24V 15A (25A)	30V 12A (20A)	48V 7.5A (12.6A)

SPECIFICATIONS

	MODEL	LFP300F-24-TY	LFP300F-30-TY	LFP300F-36-TY	LFP300F-48-TY	
INPUT	VOLTAGE[V]	AC85 - 264 1φ (Refer to "Derating", Instruction Manual 1 and 3) *5				
	CURRENT[A]	ACIN 100V	4.3typ (Io=100%)			
		ACIN 200V	2.2typ (Io=100%)			
	FREQUENCY[Hz]	50 / 60 (47 - 63)				
	EFFICIENCY[%]	ACIN 100V	85.0typ (Io=100%)	85.5typ (Io=100%)	85.5typ (Io=100%)	85.5typ (Io=100%)
		ACIN 200V	88.0typ (Io=100%)	88.0typ (Io=100%)	88.0typ (Io=100%)	88.0typ (Io=100%)
	POWER FACTOR	ACIN 100V	0.99typ (Io=100%)			
ACIN 200V		0.95typ (Io=100%)				
INRUSH CURRENT[A]	ACIN 100V	15 / 30typ (Io=100%) (Primary inrush current /Secondary inrush current) (More than 3 sec. to re-start)				
	ACIN 200V	30 / 30typ (Io=100%) (Primary inrush current /Secondary inrush current) (More than 3 sec. to re-start)				
LEAKAGE CURRENT[ma]	0.45 / 0.75max (ACIN 100V / 240V 60Hz, Io=100%, According to IEC62368-1 and DEN-AN)					
OUTPUT	VOLTAGE[V]	24	30	36	48	
	CURRENT[A]	ACIN 100V *2	12.5 (Peak 22) Convection	10 (Peak 18) Convection	8.4 (Peak 14.6) Convection	6.3 (Peak 11) Convection
			15 (Peak 22) Forced air	12 (Peak 18) Forced air	10 (Peak 14.6) Forced air	7.5 (Peak 11) Forced air
		ACIN 200V *2	12.5 (Peak 25) Convection	10 (Peak 20) Convection	8.4 (Peak 16.8) Convection	6.3 (Peak 12.6) Convection
			15 (Peak 25) Forced air	12 (Peak 20) Forced air	10 (Peak 16.8) Forced air	7.5 (Peak 12.6) Forced air
	LINE REGULATION[mV]	*7	96max	144max	144max	192max
	LOAD REGULATION[mV]	*7	150max	240max	240max	240max
	RIPPLE[mVp-p]	*3	0 to +40°C	120max	150max	150max
			-10 - 0°C	160max	200max	200max
	RIPPLE NOISE[mVp-p]*3		0 to +40°C	150max	250max	250max
			-10 - 0°C	180max	300max	300max
	TEMPERATURE REGULATION[mV]		0 to +40°C	240max	360max	480max
			-10 to +40°C	290max	450max	600max
DRIFT[mV]	*4	96max	144max	144max	192max	
START-UP TIME[ms]		350typ (ACIN 100V, Io=100%)				
HOLD-UP TIME[ms]	*9	20typ (ACIN 100V, Io=100%)				
OUTPUT VOLTAGE ADJUSTMENT RANGE[V]		21.60 to 27.50	27.00 to 33.00	32.40 to 39.60	39.60 to 52.80	
OUTPUT VOLTAGE SETTING[V]		24.00 to 24.96	30.00 to 31.20	36.00 to 37.44	48.00 to 49.92	
PROTECTION CIRCUIT AND OTHERS	OVERCURRENT PROTECTION	Works over 101% of rating and recovers automatically				
	OVERVOLTAGE PROTECTION[V]	27.60 to 33.60	34.50 to 42.00	41.40 to 50.40	55.20 to 67.20	
	OPERATING INDICATION	Not provided				
	REMOTE SENSING	Not provided				
REMOTE ON/OFF	Option (Refer to Instruction Manual 6)					
ISOLATION	INPUT-OUTPUT-RC	*6	AC3,000V 1minute, Cutoff current = 10mA, DC500V 50MΩ min (At Room Temperature)			
	INPUT-FG		AC2,000V 1minute, Cutoff current = 10mA, DC500V 50MΩ min (At Room Temperature)			
	OUTPUT-RC-FG	*6	AC500V 1minute, Cutoff current = 25mA, DC500V 50MΩ min (At Room Temperature)			
	OUTPUT-RC	*6	AC100V 1minute, Cutoff current = 25mA, DC100V 10MΩ min (At Room Temperature)			
ENVIRONMENT	OPERATING TEMP., HUMID. AND ALTITUDE *5	-10 to +70°C, 20 - 90%RH (Non condensing) (Refer to "Derating", Instruction Manual 3), 3,000m (10,000feet) max				
	STORAGE TEMP., HUMID. AND ALTITUDE	-20 to +75°C, 20 - 90%RH (Non condensing), 9,000m (30,000feet) max				
	VIBRATION	10 - 55Hz, 19.6m/s ² (2G), 3minutes period, 60minutes each along X, Y and Z axis				
	IMPACT	196.1m/s ² (20G), 11ms, once each X, Y and Z axis				
SAFETY AND NOISE REGULATIONS	AGENCY APPROVALS (At only AC input)	UL60950-1, C-UL (CSA60950-1), EN62368-1 Complies with DEN-AN				
	CONDUCTED NOISE	Complies with FCC-B, VCCI-B, CISPR22-B, EN55011-B, EN55022-B				
	HARMONIC ATTENUATOR	Complies with IEC61000-3-2 (Class A) *8				
OTHERS	CASE SIZE/WEIGHT	95X52.5X222mm [3.74X2.07X8.74 inches] (W X H X D) (without terminal block) / 810g max (with chassis & cover : 1,270g max)				
	COOLING METHOD	Convection / Forced air (Refer to "Derating", Instruction Manual 3) *5				

*1 Specification is changed at option, refer to Instruction Manual.

*2 Peak loading for 10sec. And Duty 40% max, refer to Instruction Manual 6. In detail.

() means peak current. There is a possibility that an internal device is damaged when the specification is exceeded.

*3 This is the value that measured on measuring board with capacitor of 22μF at 150mm from output terminal.

Measured by 20MHz oscilloscope or Ripple-Noise meter (Equivalent to KEISOKU-GIKEN: RM103).

*4 Drift is the change in DC output for an eight hour period after a half-hour warm-up at 25°C, with the input voltage held constant at the rated input/output.

*5 Derating is required.

*6 Applicable when remote control (optional) is added.

*7 Please contact us about dynamic load and input response.

*8 Please contact us about another class.

*9 By attaching an external capacitor unit, it is possible to extend the hold-up time.

* To meet the specifications. Do not operate over-loaded condition.

* Parallel operation is not possible.

* Derating is required when operated with chassis and cover.

* Sound noise may be generated by power supply in case of pulse load.

Block diagram

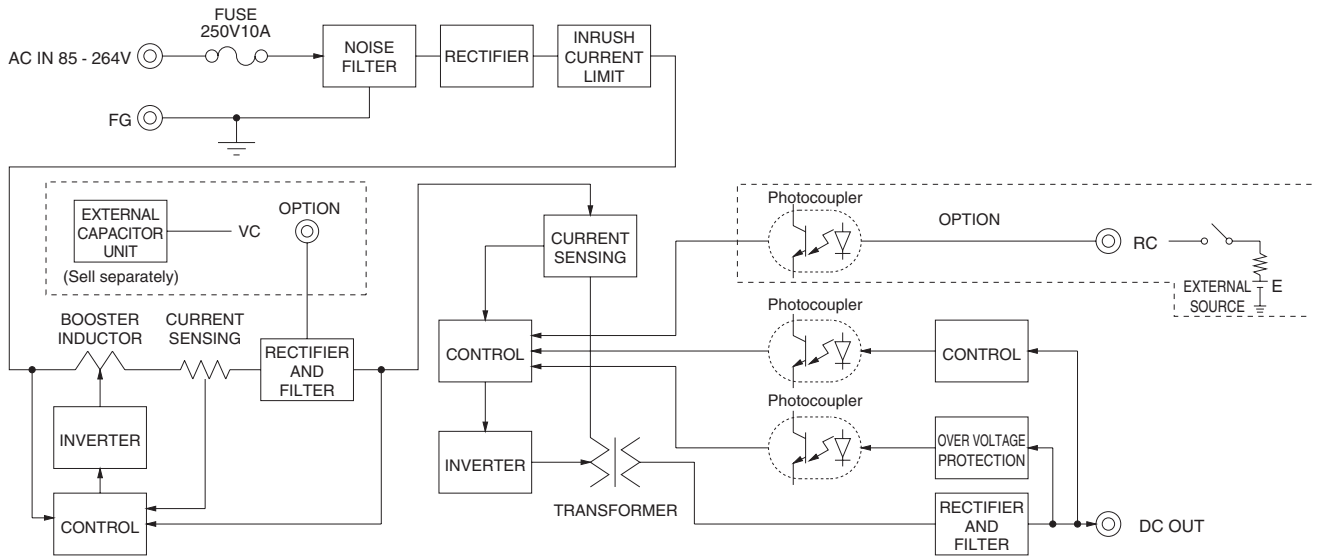

External view

※ External size of option is different from standard model.

Standard type

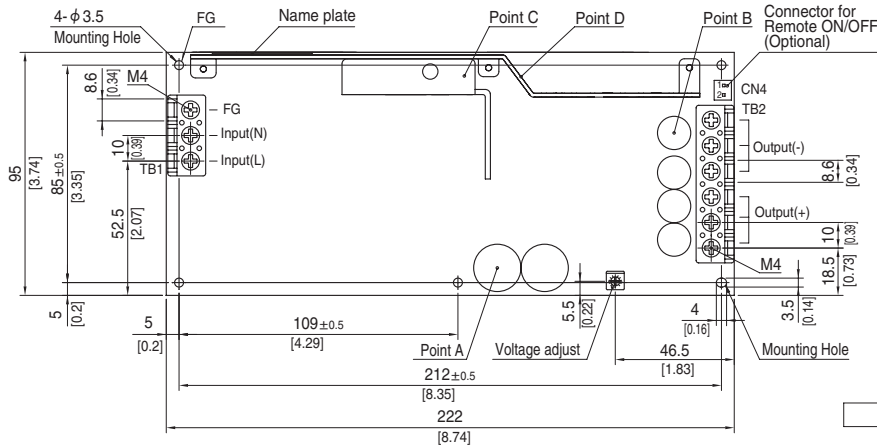

Connector type

CN4 Option (Mfr.:J.S.T)

PIN No.	Contents
1	RC(+)
2	RC(-)

Barrier strip type

Model B2B-XH-A
Mating Connector (Terminal)
XHP-2
(BXH-001T-P0.6
or SXH-001T-P0.6)

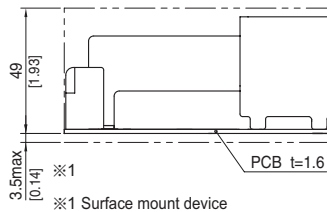

- ※ 5 Mounting holes are existing.
- ※ The back side of P.C.B. of the power supply is assembled some SMDs.
Be attention not to bump against the attached area by vibration.
- ※ Use the spacer of 8mm length or more regarding insulation.
And do not use press-fitting bush.
- ※ Point A, Point B, Point C, Point D are thermometry points.
Please refer to Instruction Manual 3.
- ※ Keep drawing current per pin below 20A for TB2.

- ※ Tolerance : ± 1 [± 0.04]
- ※ Weight : 810g max (with chassis & cover : 1,270g max)
- ※ PCB material : CEM3
- ※ Dimensions in mm, []=inches
- ※ Screw tightening torque : M4 1.6N · m (16.9kgf · cm) max

Assembling and Installation Method

Installation method

■ This power supply is manufactured by SMD technology. The stress to P.C.B like twisting or bending causes the defect of the unit, so handle the unit with care.

■ In case of metal chassis, keep the distance between d1 & d2 for to insulate between lead of component and metal chassis, use the spacer of 8mm or more between d1. If it is less than d1 & d2, insert the insulation sheet between power supply and metal chassis.

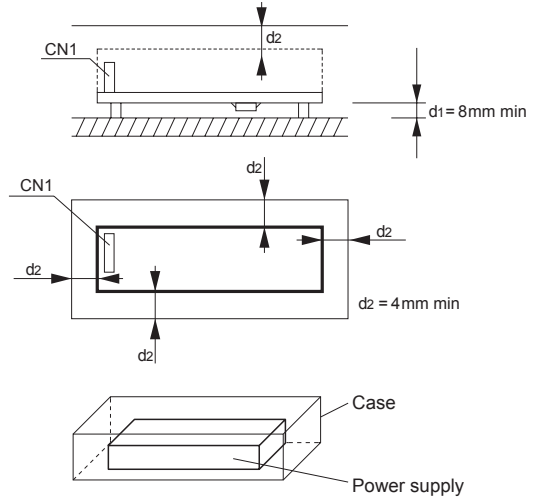

■ There is a possibility that it is not possible to cool enough when the power supply is used by the sealing up space as showing in right figure. Please use it after confirming the temperature of point A and point B of Instruction Manual 3.

■ (F) of LFP300F is not possible. (F) mounting is not possible when unit is with case cover, but if need to operate unit by (F) positioning with case cover, temperature / load derating is necessary.

For more details, please contact our sales or engineering departments.

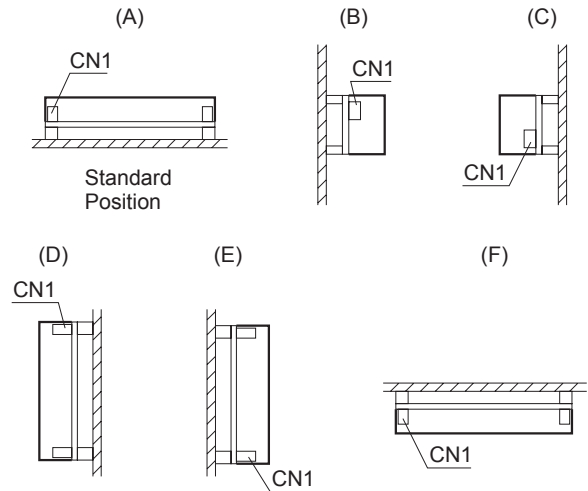

Mounting screw

■ The mounting screw should be M3. The hatched area shows the allowance of metal parts for mounting.

● LFP100F, LFP150F

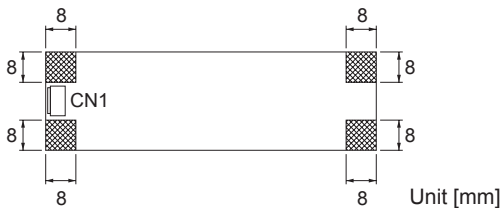

● LFP240F, LFP300F

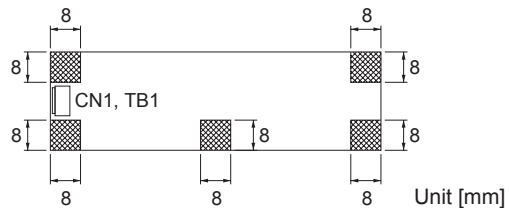

■ If metallic fittings are used on the component side of the board, ensure there is no contact with surface mounted components.

■ This product uses SMD technology. Please avoid the PCB installation method which includes the twisting stress or the bending stress.

*Recommendation to electrically connect FG to metal chassis for reducing noise.

Derating

Derating curve for input voltage

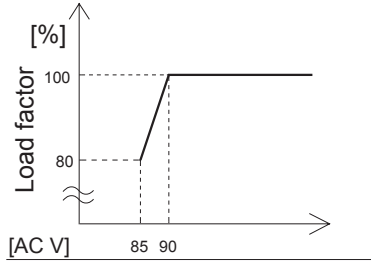

LFP100F Ambient temperature derating curve (Reference value)

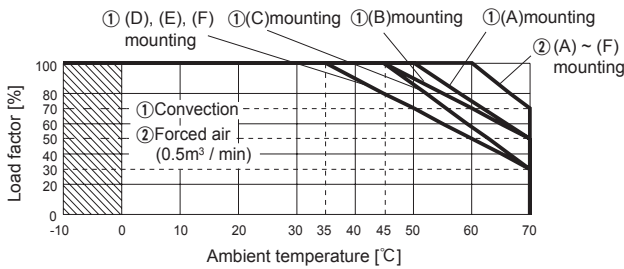

LFP150F Ambient temperature derating curve (Reference value)

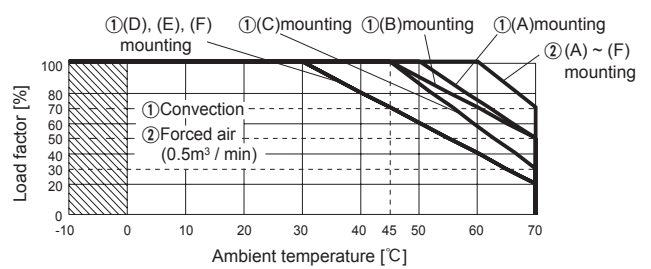

LFP240F Ambient temperature derating curve (Reference value)

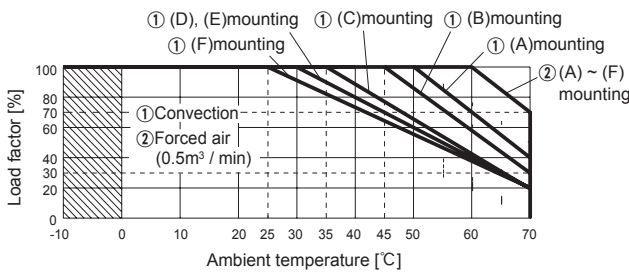

Output voltage	Output power[W]	
	①Convection	②Forced air
24V	240.0	300.0
30V	240.0	300.0
36V	241.2	302.4
48V	240.0	302.4

LFP300F Ambient temperature derating curve (Reference value)

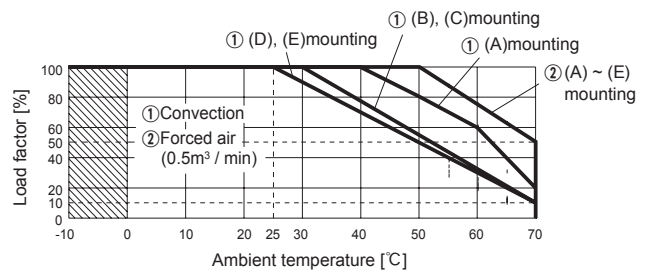

Output voltage	Output power[W]	
	①Convection	②Forced air
24V	300.0	360.0
30V	300.0	360.0
36V	302.4	360.0
48V	302.4	360.0

■The operative ambient temperature is different by with / without chassis cover or mounting position.

Note: In the hatched area, the specification of Ripple, Ripple Noise is different from other area.

■Make sure the temperature at point A and point B is less than the temperatures shown in Instruction Manual 3.

■The ambient temperature should be measured 5 to 10 cm away from the power supply so that it won't be influenced by the heat from the power supply. Please consult us for more details.

Instruction Manual

◆ It is necessary to read the "Instruction Manual" and "Before using our product" before you use our product.

Instruction Manual <https://www.cosel.co.jp/redirect/catalog/en/LFP/>
 Before using our product <https://en.cosel.co.jp/technical/caution/index.html>

LFP



NOTICE



Basic Characteristics Data

Model	Circuit method	Switching frequency [kHz]	Input current *1 [A]	Inrush current protection	PCB/Pattern			Series/Parallel operation availability *2	
					Material	Single sided	Double sided	Series operation	Parallel operation
LFP100F	Active filter	60	1.3	Thermistor	CEM-3		Yes	Yes	No
	Forward converter	130							
LFP150F	Active filter	60	2.0	Thermistor	CEM-3		Yes	Yes	No
	Forward converter	130							
LFP240F	Active filter	60	3.6	SCR	CEM-3		Yes	Yes	No
	Forward converter	130							
LFP300F	Active filter	60	4.3	SCR	CEM-3		Yes	Yes	No
	Forward converter	140							

*1 The value of input current is at ACIN 100V and rated load.

*2 Refer to Instruction Manual 2.



World wide



Isolated

Safety
Approvals

OCP



OVP

TUHS-series

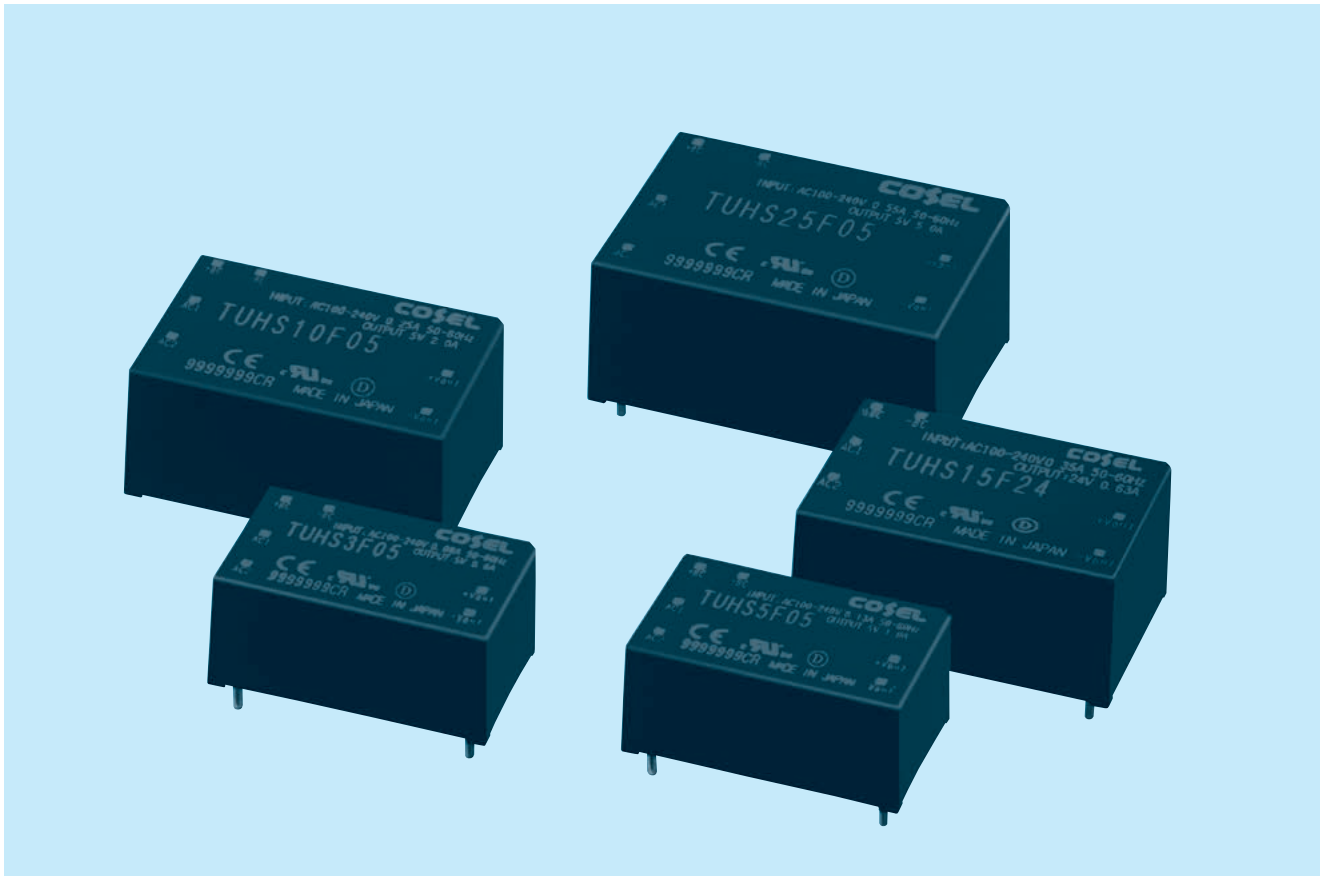

TUHS

Feature

- P.C.board mount AC-DC Converter
- Design flexibility for Hold-Up time and expected life
- Small size
- Built-in overcurrent and overvoltage protection circuits
- High efficiency by synchronous rectification technology (TUHS25)
- Not built-in aluminum and tantalum electrolytic capacitor

CE marking

- Low voltage directive
- RoHS Directive

UKCA marking

- Electrical Equipment Safety Regulations
- RoHS Regulations

Safety Approval

- UL60950-1, C-UL, EN62368-1

5-year warranty

TUHS3

TUH S 3 F 05

① ② ③ ④ ⑤

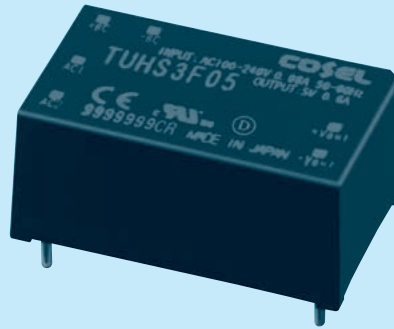

- ① Series name
- ② Single output
- ③ Output wattage
- ④ Universal Input
- ⑤ Output voltage

□ Class II

* Avoid short circuit between +BC and -BC. It may cause the failure of inside components.
 * To use TUHS, external components are required. Refer to the instruction manual for details.

MODEL	TUHS3F05	TUHS3F12	TUHS3F15	TUHS3F24
MAX OUTPUT WATTAGE[W]	3.00	3.00	3.00	3.12
DC OUTPUT	5V 0.6A	12V 0.25A	15V 0.2A	24V 0.13A

SPECIFICATIONS

	MODEL	TUHS3F05	TUHS3F12	TUHS3F15	TUHS3F24	
INPUT	VOLTAGE[V]	AC85 - 264 1 φ DC120 - 370				
	CURRENT[A]	ACIN 100V	0.08typ (Io=100%)			
		ACIN 200V	0.05typ (Io=100%)			
	FREQUENCY[Hz]	50/60 (47 - 63)				
	EFFICIENCY[%]	ACIN 100V	79typ	81typ	81typ	81typ
ACIN 200V		78typ	79typ	79typ	79typ	
INRUSH CURRENT		Limited by external components				
OUTPUT	VOLTAGE[V]	5	12	15	24	
	CURRENT[A]	0.6	0.25	0.2	0.13	
	LINE REGULATION[mV]	20max	48max	60max	96max	
	LOAD REGULATION[mV]	40max	100max	120max	150max	
	RIPPLE[mVp-p]	30 to 100% Load *1	120max	160max	160max	200max
		0 to 30% Load AC85V - 240V *1	400max	480max	480max	580max
	RIPPLE NOISE[mVp-p]	30 to 100% Load *1	160max	200max	200max	240max
		0 to 30% Load AC85V - 240V *1	480max	560max	560max	660max
	TEMPERATURE REGULATION[mV]	0 to +85°C	100max	180max	240max	360max
		-40 to +85°C	150max	270max	360max	480max
DRIFT[mV]	*2	20max	48max	60max	96max	
OUTPUT VOLTAGE SETTING[V]		4.90 - 5.30	11.40 - 12.60	14.25 - 15.75	23.00 - 25.00	
PROTECTION CIRCUIT AND OTHERS	OVERCURRENT PROTECTION	Works over 105% of rating and recover automatically				
	OVERVOLTAGE PROTECTION[V]	5.50 - 8.00	13.20 - 19.20	16.50 - 24.00	26.40 - 38.40	
ISOLATION	INPUT-OUTPUT	AC3,000V 1minute, Cutoff current = 10mA, DC500V 50MΩ min (20±15°C)				
ENVIRONMENT	OPERATING TEMP., HUMID. AND ALTITUDE	-40 to +85°C, 20 - 95%RH (Non condensing) (Refer to "Derating"), 3,000m (10,000 feet) max				
	STORAGE TEMP., HUMID. AND ALTITUDE	-40 to +100°C, 20 - 95%RH (Non condensing), 9,000m (30,000 feet) max				
	VIBRATION	10 - 55Hz, 49.0m/s ² (5G), 3minutes period, 60minutes each along X, Y and Z axis				
	IMPACT	196.1m/s ² (20G), 11ms, once each along X, Y and Z axis				
SAFETY AND NOISE REGULATIONS	AGENCY APPROVALS	UL60950-1, C-UL (CSA60950-1), EN62368-1				
	CONDUCTED NOISE	Complies with FCC-B, VCCI-B, CISPR-B, EN55022-B *3				
	HARMONIC ATTENUATOR	Complies with IEC61000-3-2 (Class A) (Not built-in to active filter)				
OTHERS	CASE SIZE/WEIGHT	28.7 X 12.7 X 17.5mm[1.13 X 0.50 X 0.69 inches] (W X H X D) / 15g max				
	COOLING METHOD	Convection / Forced air				

*1 Refer to instruction manual for measuring method of electric characteristics.
 *2 Drift is the change in DC output for an eight hour period after a half-hour warm-up at 25°C, with the input voltage held constant at the rated value.
 *3 Do not ground secondly circuit, in case of a standard adapted.
 * Measured with 18μF capacitor as Cbc.

External view

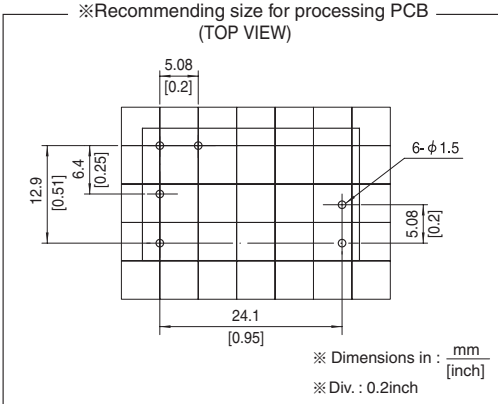
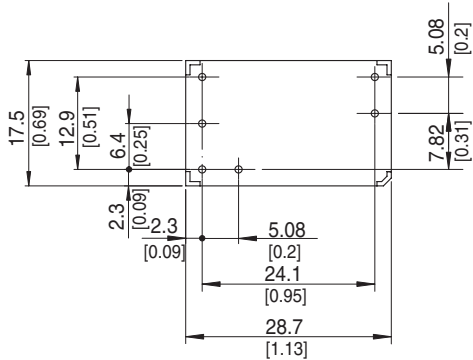
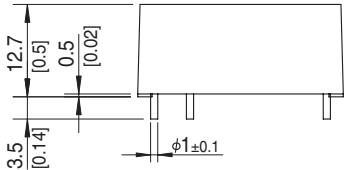
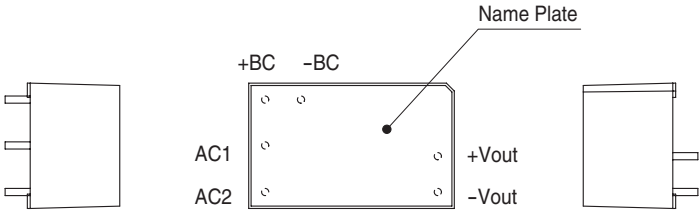

- ※ Tolerance : ± 0.5 [± 0.02]
- ※ Weight : 15g max
- ※ Case material : PBT
- ※ Pin material : Copper
- ※ Plating treatment of pin : Lead free plating
- ※ Dimensions in mm, []=inches

TUHS

TUHS5

TUH S 5 F 05

① ② ③ ④ ⑤

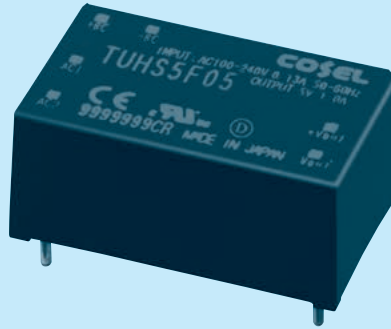

- ① Series name
- ② Single output
- ③ Output wattage
- ④ Universal Input
- ⑤ Output voltage

□ Class II

* Avoid short circuit between +BC and -BC. It may cause the failure of inside components.
 * To use TUHS, external components are required. Refer to the instruction manual for details.

MODEL	TUHS5F05	TUHS5F12	TUHS5F15	TUHS5F24
MAX OUTPUT WATTAGE[W]	5.00	5.40	5.10	5.28
DC OUTPUT	5V 1A	12V 0.45A	15V 0.34A	24V 0.22A

SPECIFICATIONS

	MODEL	TUHS5F05	TUHS5F12	TUHS5F15	TUHS5F24	
INPUT	VOLTAGE[V]	AC85 - 264 1 φ DC120 - 370				
	CURRENT[A]	ACIN 100V	0.13typ (Io=100%)			
		ACIN 200V	0.08typ (Io=100%)			
	FREQUENCY[Hz]	50/60 (47 - 63)				
	EFFICIENCY[%]	ACIN 100V	78typ	82typ	82typ	83typ
		ACIN 200V	79typ	82typ	82typ	83typ
INRUSH CURRENT	Limited by external components					
OUTPUT	VOLTAGE[V]	5	12	15	24	
	CURRENT[A]	1	0.45	0.34	0.22	
	LINE REGULATION[mV]	20max	48max	60max	96max	
	LOAD REGULATION[mV]	40max	100max	120max	150max	
	RIPPLE[mVp-p]	30 to 100% Load *1	120max	160max	160max	200max
		0 to 30% Load AC85V - 240V *1	400max	480max	480max	580max
	RIPPLE NOISE[mVp-p]	30 to 100% Load *1	160max	200max	200max	240max
		0 to 30% Load AC85V - 240V *1	480max	560max	560max	660max
	TEMPERATURE REGULATION[mV]	0 to +80°C	100max	180max	240max	360max
		-40 to +80°C	150max	270max	360max	480max
DRIFT[mV]	*2	20max	48max	60max	96max	
OUTPUT VOLTAGE SETTING[V]		4.90 - 5.30	11.40 - 12.60	14.25 - 15.75	23.00 - 25.00	
PROTECTION CIRCUIT AND OTHERS	OVERCURRENT PROTECTION	Works over 105% of rating and recover automatically				
	OVERVOLTAGE PROTECTION[V]	5.50 - 8.00	13.20 - 19.20	16.50 - 24.00	26.40 - 38.40	
ISOLATION	INPUT-OUTPUT	AC3,000V 1minute, Cutoff current = 10mA, DC500V 50MΩ min (20±15°C)				
ENVIRONMENT	OPERATING TEMP., HUMID. AND ALTITUDE	-40 to +85°C, 20 - 95%RH (Non condensing) (Refer to "Derating"), 3,000m (10,000 feet) max				
	STORAGE TEMP., HUMID. AND ALTITUDE	-40 to +100°C, 20 - 95%RH (Non condensing), 9,000m (30,000 feet) max				
	VIBRATION	10 - 55Hz, 49.0m/s ² (5G), 3minutes period, 60minutes each along X, Y and Z axis				
	IMPACT	196.1m/s ² (20G), 11ms, once each along X, Y and Z axis				
SAFETY AND NOISE REGULATIONS	AGENCY APPROVALS	UL60950-1, C-UL (CSA60950-1), EN62368-1				
	CONDUCTED NOISE	Complies with FCC-B, VCCI-B, CISPR-B, EN55022-B *3				
	HARMONIC ATTENUATOR	Complies with IEC61000-3-2 (Class A) (Not built-in to active filter)				
OTHERS	CASE SIZE/WEIGHT	28.7 X 12.7 X 17.5mm[1.13 X 0.50 X 0.69 inches] (W X H X D) / 15g max				
	COOLING METHOD	Convection / Forced air				

*1 Refer to instruction manual for measuring method of electric characteristics.
 *2 Drift is the change in DC output for an eight hour period after a half-hour warm-up at 25°C, with the input voltage held constant at the rated value.
 *3 Do not ground secondly circuit, in case of a standard adapted.
 * Measured with 22μF capacitor as Cbc.

External view

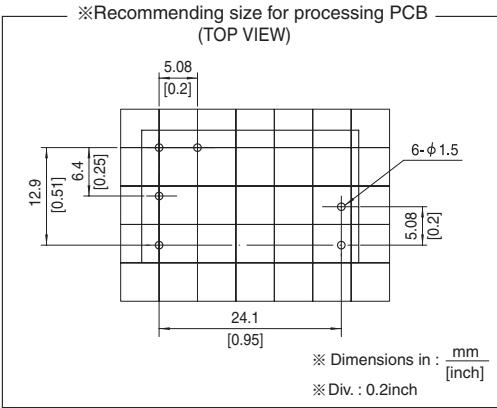
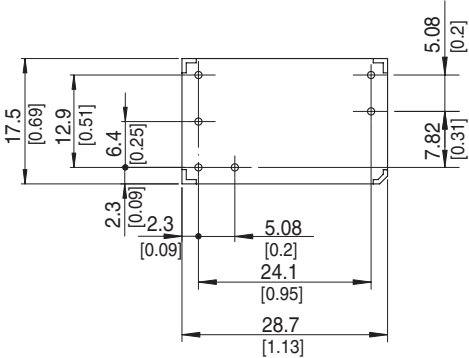
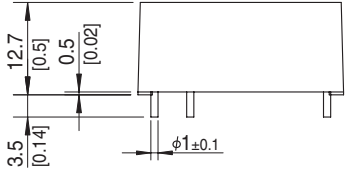
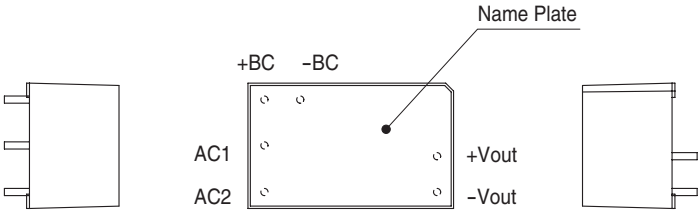

- ※ Tolerance : ± 0.5 [± 0.02]
- ※ Weight : 15g max
- ※ Case material : PBT
- ※ Pin material : Copper
- ※ Plating treatment of pin : Lead free plating
- ※ Dimensions in mm, []=inches

TUHS10

TUH S 10 F 05

① ② ③ ④ ⑤

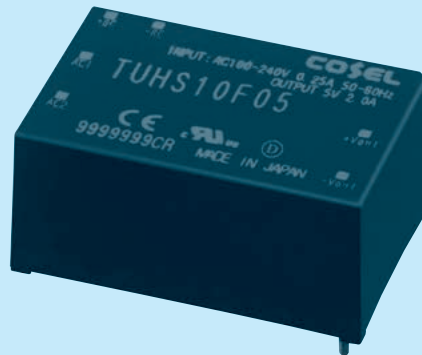

- ① Series name
- ② Single output
- ③ Output wattage
- ④ Universal Input
- ⑤ Output voltage

□ Class II

* Avoid short circuit between +BC and -BC. It may cause the failure of inside components.
 * To use TUHS, external components are required. Refer to the instruction manual for details.

MODEL	TUHS10F05	TUHS10F12	TUHS10F15	TUHS10F24
MAX OUTPUT WATTAGE[W]	10.00	10.80	10.10	10.80
DC OUTPUT	5V 2A	12V 0.9A	15V 0.67A	24V 0.45A

SPECIFICATIONS

	MODEL	TUHS10F05	TUHS10F12	TUHS10F15	TUHS10F24	
INPUT	VOLTAGE[V]	AC85 - 264 1 φ DC120 - 370				
	CURRENT[A]	ACIN 100V	0.25typ (Io=100%)			
		ACIN 200V	0.14typ (Io=100%)			
	FREQUENCY[Hz]	50/60 (47 - 63)				
	EFFICIENCY[%]	ACIN 100V	81typ	85typ	85typ	86typ
		ACIN 200V	82typ	85typ	85typ	87typ
INRUSH CURRENT	Limited by external components					
OUTPUT	VOLTAGE[V]	5	12	15	24	
	CURRENT[A]	2	0.9	0.67	0.45	
	LINE REGULATION[mV]	20max	48max	60max	96max	
	LOAD REGULATION[mV]	40max	100max	120max	150max	
	RIPPLE[mVp-p]	30 to 100% Load *1	120max	160max	160max	200max
		0 to 30% Load AC85V - 240V *1	400max	480max	480max	580max
	RIPPLE NOISE[mVp-p]	30 to 100% Load *1	160max	200max	200max	240max
		0 to 30% Load AC85V - 240V *1	480max	560max	560max	660max
	TEMPERATURE REGULATION[mV]	0 to +70°C	100max	180max	240max	360max
		-40 to +70°C	150max	270max	360max	480max
DRIFT[mV]	*2	20max	48max	60max	96max	
OUTPUT VOLTAGE SETTING[V]		4.90 - 5.30	11.40 - 12.60	14.25 - 15.75	23.00 - 25.00	
PROTECTION CIRCUIT AND OTHERS	OVERCURRENT PROTECTION	Works over 105% of rating and recover automatically				
	OVERVOLTAGE PROTECTION[V]	5.50 - 8.00	13.20 - 19.20	16.50 - 24.00	26.40 - 38.40	
ISOLATION	INPUT-OUTPUT	AC3,000V 1minute, Cutoff current = 10mA, DC500V 50MΩ min (20±15°C)				
ENVIRONMENT	OPERATING TEMP., HUMID. AND ALTITUDE	-40 to +85°C, 20 - 95%RH (Non condensing) (Refer to "Derating"), 3,000m (10,000 feet) max				
	STORAGE TEMP., HUMID. AND ALTITUDE	-40 to +100°C, 20 - 95%RH (Non condensing), 9,000m (30,000 feet) max				
	VIBRATION	10 - 55Hz, 49.0m/s ² (5G), 3minutes period, 60minutes each along X, Y and Z axis				
	IMPACT	196.1m/s ² (20G), 11ms, once each along X, Y and Z axis				
SAFETY AND NOISE REGULATIONS	AGENCY APPROVALS	UL60950-1, C-UL (CSA60950-1), EN62368-1				
	CONDUCTED NOISE	Complies with FCC-B, VCCI-B, CISPR-B, EN55022-B *3				
	HARMONIC ATTENUATOR	Complies with IEC61000-3-2 (Class A) (Not built-in to active filter)				
OTHERS	CASE SIZE/WEIGHT	33.0 X 15.0 X 22.0mm [1.3 X 0.59 X 0.86 inches] (W X H X D) / 25g max				
	COOLING METHOD	Convection / Forced air				

*1 Refer to instruction manual for measuring method of electric characteristics.
 *2 Drift is the change in DC output for an eight hour period after a half-hour warm-up at 25°C, with the input voltage held constant at the rated value.
 *3 Do not ground secondly circuit, in case of a standard adapted.
 * Measured with 47μF capacitor as Cbc.

External view

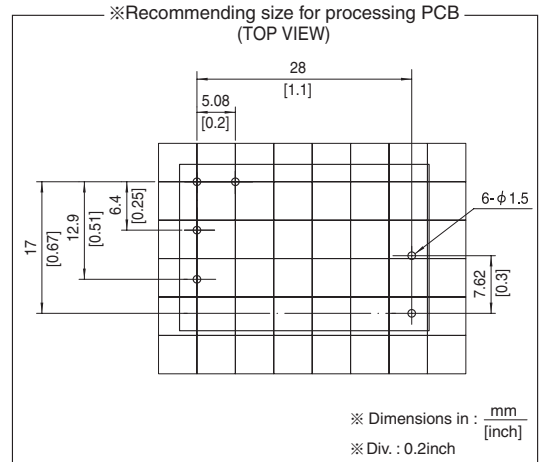
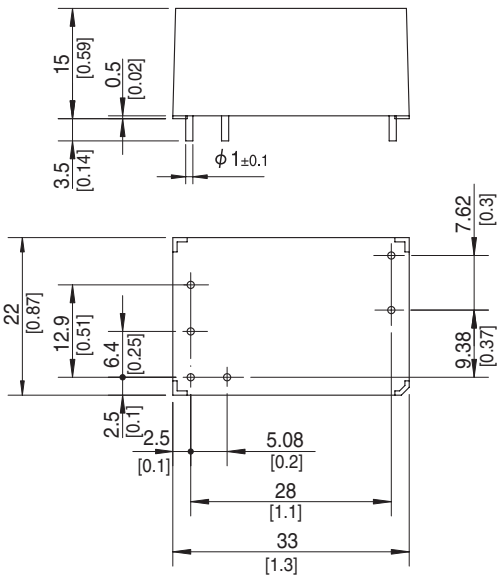
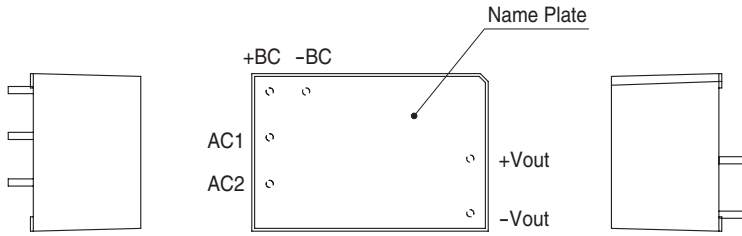

※ Dimensions in : $\frac{\text{mm}}{\text{[inch]}}$
 ※ Div. : 0.2inch

- ※ Tolerance : ± 0.5 [± 0.02]
- ※ Weight : 25g max
- ※ Case material : PBT
- ※ Pin material : Copper
- ※ Plating treatment of pin : Lead free plating
- ※ Dimensions in mm, []=inches

TUHS

TUHS15

TUH S 15 F 12

① ② ③ ④ ⑤

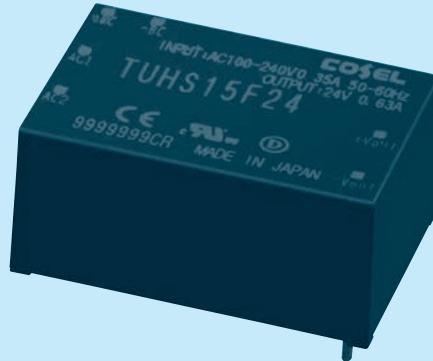

- ① Series name
- ② Single output
- ③ Output wattage
- ④ Universal Input
- ⑤ Output voltage

□ Class II

* Avoid short circuit between +BC and -BC. It may cause the failure of inside components.
 * To use TUHS, external components are required. Refer to the instruction manual for details.

MODEL	TUHS15F12	TUHS15F15	TUHS15F24
MAX OUTPUT WATTAGE[W]	15.00	15.00	15.12
DC OUTPUT	12V 1.25A	15V 1A	24V 0.63A

SPECIFICATIONS

	MODEL	TUHS15F12	TUHS15F15	TUHS15F24	
INPUT	VOLTAGE[V]	AC85 - 264 1 φ DC120 - 370			
	CURRENT[A]	ACIN 100V	0.35typ (Io=100%)		
		ACIN 200V	0.18typ (Io=100%)		
	FREQUENCY[Hz]	50/60 (47 - 63)			
	EFFICIENCY[%]	ACIN 100V	85typ	85typ	86typ
		ACIN 200V	85typ	85typ	87typ
INRUSH CURRENT	Limited by external components				
OUTPUT	VOLTAGE[V]	12	15	24	
	CURRENT[A]	1.25	1	0.63	
	LINE REGULATION[mV]	48max	60max	96max	
	LOAD REGULATION[mV]	100max	120max	150max	
	RIPPLE[mVp-p]	30 to 100% Load *1	160max	160max	200max
		0 to 30% Load AC85V - 240V *1	480max	480max	580max
	RIPPLE NOISE[mVp-p]	30 to 100% Load *1	200max	200max	240max
		0 to 30% Load AC85V - 240V *1	560max	560max	660max
	TEMPERATURE REGULATION[mV]	0 to +50°C	180max	240max	360max
		-40 to +50°C	270max	360max	480max
DRIFT[mV]	*2	48max	60max	96max	
OUTPUT VOLTAGE SETTING[V]	11.40 - 12.60	14.25 - 15.75	23.00 - 25.00		
PROTECTION CIRCUIT AND OTHERS	OVERCURRENT PROTECTION	Works over 105% of rating and recover automatically			
	OVERVOLTAGE PROTECTION[V]	13.20 - 19.20	16.50 - 24.00	26.40 - 38.40	
ISOLATION	INPUT-OUTPUT	AC3,000V 1minute, Cutoff current = 10mA, DC500V 50MΩ min (20±15°C)			
ENVIRONMENT	OPERATING TEMP., HUMID. AND ALTITUDE	-40 to +85°C, 20 - 95%RH (Non condensing) (Refer to "Derating"), 3,000m (10,000 feet) max			
	STORAGE TEMP., HUMID. AND ALTITUDE	-40 to +100°C, 20 - 95%RH (Non condensing), 9,000m (30,000 feet) max			
	VIBRATION	10 - 55Hz, 49.0m/s ² (5G), 3minutes period, 60minutes each along X, Y and Z axis			
	IMPACT	196.1m/s ² (20G), 11ms, once each along X, Y and Z axis			
SAFETY AND NOISE REGULATIONS	AGENCY APPROVALS	UL60950-1, C-UL (CSA60950-1), EN62368-1			
	CONDUCTED NOISE	Complies with FCC-B, VCCI-B, CISPR-B, EN55022-B *3			
	HARMONIC ATTENUATOR	Complies with IEC61000-3-2 (Class A) (Not built-in to active filter)			
OTHERS	CASE SIZE/WEIGHT	33.0 × 15.0 × 22.0mm [1.3 × 0.59 × 0.86 inches] (W × H × D) / 25g max			
	COOLING METHOD	Convection / Forced air			

*1 Refer to instruction manual for measuring method of electric characteristics.
 *2 Drift is the change in DC output for an eight hour period after a half-hour warm-up at 25°C, with the input voltage held constant at the rated value.
 *3 Do not ground secondly circuit, in case of a standard adapted.
 * Measured with 68μF capacitor as Cbc.

External view

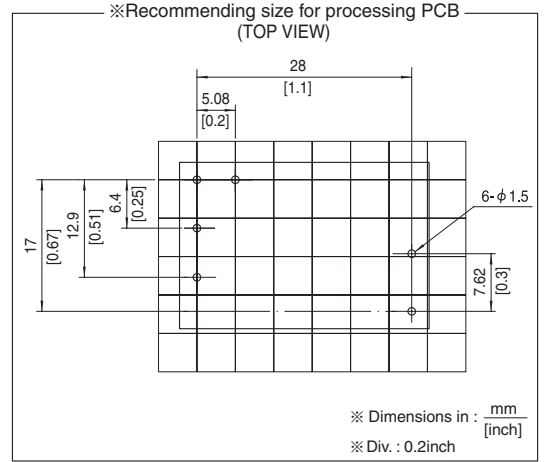
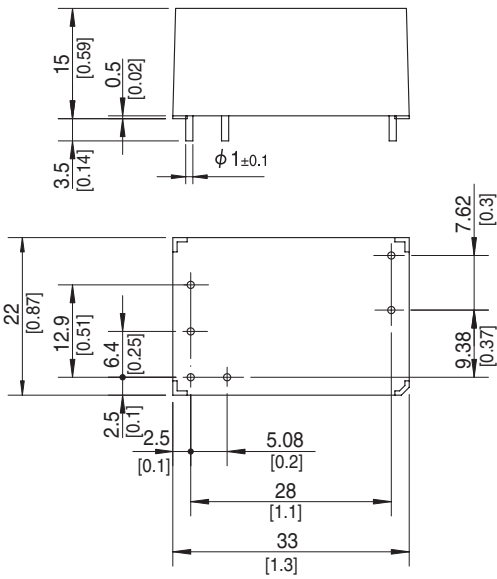
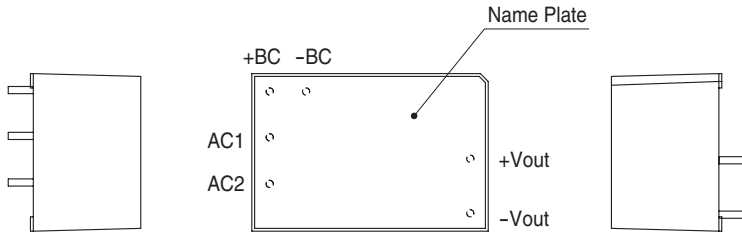

※ Dimensions in : $\frac{\text{mm}}{[\text{inch}]}$
 ※ Div. : 0.2inch

- ※ Tolerance : ± 0.5 [± 0.02]
- ※ Weight : 25g max
- ※ Case material : PBT
- ※ Pin material : Copper
- ※ Plating treatment of pin : Lead free plating
- ※ Dimensions in mm, []=inches

TUHS

TUHS25

TUH S 25 F 05

① ② ③ ④ ⑤

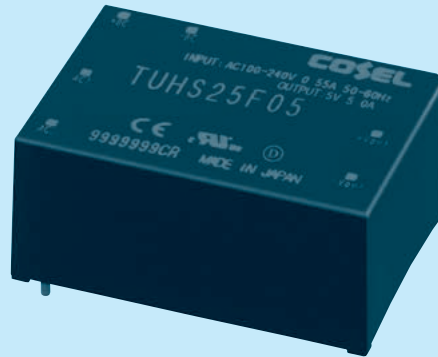

- ① Series name
- ② Single output
- ③ Output wattage
- ④ Universal Input
- ⑤ Output voltage

□ Class II

* Avoid short circuit between +BC and -BC. It may cause the failure of inside components.
 * To use TUHS, external components are required. Refer to the instruction manual for details.

TUHS

MODEL	TUHS25F05	TUHS25F12	TUHS25F15	TUHS25F24
MAX OUTPUT WATTAGE[W]	25.00	25.20	25.50	26.40
DC OUTPUT	5V 5A	12V 2.1A	15V 1.7A	24V 1.1A

SPECIFICATIONS

	MODEL	TUHS25F05	TUHS25F12	TUHS25F15	TUHS25F24	
INPUT	VOLTAGE[V]	AC85 - 264 1 φ DC120 - 370				
	CURRENT[A]	ACIN 100V	0.55typ (Io=100%)			
		ACIN 200V	0.35typ (Io=100%)			
	FREQUENCY[Hz]	50/60 (47 - 63)				
	EFFICIENCY[%]	ACIN 100V	87typ	88typ	88typ	89typ
		ACIN 200V	87typ	88typ	88typ	90typ
INRUSH CURRENT	Limited by external components					
OUTPUT	VOLTAGE[V]	5	12	15	24	
	CURRENT[A]	5	2.1	1.7	1.1	
	LINE REGULATION[mV]	20max	48max	60max	96max	
	LOAD REGULATION[mV]	40max	100max	120max	150max	
	RIPPLE[mVp-p]	30 to 100% Load *1	120max	160max	160max	200max
		0 to 30% Load AC85V - 240V *1	400max	480max	480max	580max
	RIPPLE NOISE[mVp-p]	30 to 100% Load *1	160max	200max	200max	240max
		0 to 30% Load AC85V - 240V *1	480max	560max	560max	660max
	TEMPERATURE REGULATION[mV]	0 to +50°C	100max	180max	240max	360max
		-40 to +50°C	150max	270max	360max	480max
DRIFT[mV]	*2	20max	48max	60max	96max	
OUTPUT VOLTAGE SETTING[V]		4.90 - 5.30	11.40 - 12.60	14.25 - 15.75	23.00 - 25.00	
PROTECTION CIRCUIT AND OTHERS	OVERCURRENT PROTECTION	Works over 105% of rating and recover automatically				
	OVERVOLTAGE PROTECTION[V]	5.50 - 8.00	13.20 - 19.20	16.50 - 24.00	26.40 - 38.40	
ISOLATION	INPUT-OUTPUT	AC3,000V 1minute, Cutoff current = 10mA, DC500V 50MΩ min (20±15°C)				
ENVIRONMENT	OPERATING TEMP., HUMID. AND ALTITUDE	-40 to +85°C, 20 - 95%RH (Non condensing) (Refer to "Derating"), 3,000m (10,000 feet) max				
	STORAGE TEMP., HUMID. AND ALTITUDE	-40 to +100°C, 20 - 95%RH (Non condensing), 9,000m (30,000 feet) max				
	VIBRATION	10 - 55Hz, 49.0m/s ² (5G), 3minutes period, 60minutes each along X, Y and Z axis				
	IMPACT	196.1m/s ² (20G), 11ms, once each along X, Y and Z axis				
SAFETY AND NOISE REGULATIONS	AGENCY APPROVALS	UL60950-1, C-UL (CSA60950-1), EN62368-1				
	CONDUCTED NOISE	Complies with FCC-B, VCCI-B, CISPR-B, EN55022-B *3				
	HARMONIC ATTENUATOR	Complies with IEC61000-3-2 (Class A) (Not built-in to active filter)				
OTHERS	CASE SIZE/WEIGHT	36.0 X 16.5 X 25.4mm [1.42 X 0.65 X 1.0 inches] (W X H X D) / 40g max				
	COOLING METHOD	Convection / Forced air				

*1 Refer to instruction manual for measuring method of electric characteristics.
 *2 Drift is the change in DC output for an eight hour period after a half-hour warm-up at 25°C, with the input voltage held constant at the rated value.
 *3 Do not ground secondly circuit, in case of a standard adapted.
 * Measured with 120μF capacitor as Cbc.

External view

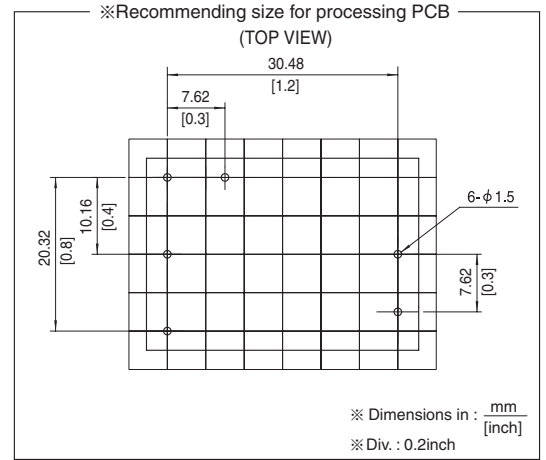
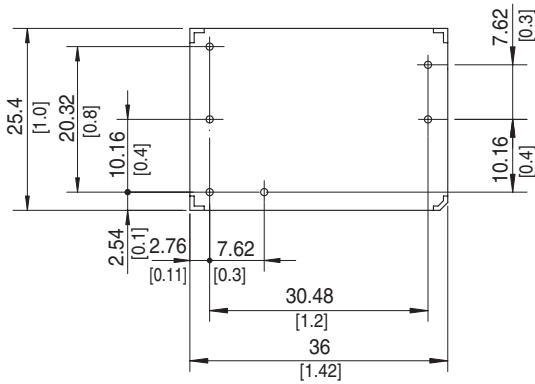
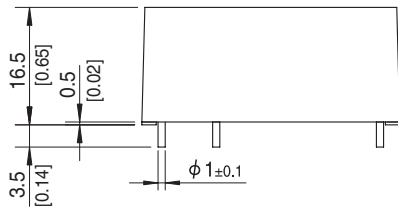
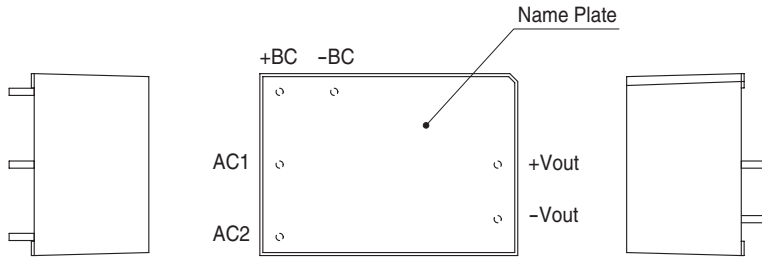

- ※ Tolerance : ± 0.5 [± 0.02]
- ※ Weight : 40g max
- ※ Case material : PBT
- ※ Pin material : Copper
- ※ Plating treatment of pin : Lead free plating
- ※ Dimensions in mm, []=inches

Pin Configuration

●TUHS3/TUHS5

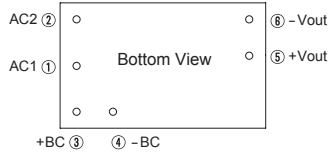

No.	Pin Connection	Function
①	AC1	AC input
②	AC2	
③	+BC	+BC output
④	-BC	-BC output
⑤	+VOUT	+DC output
⑥	-VOUT	-DC output

●TUHS10/TUHS15

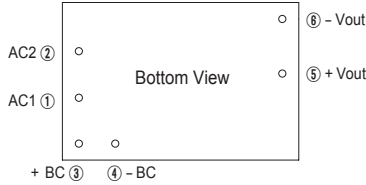

●TUHS25

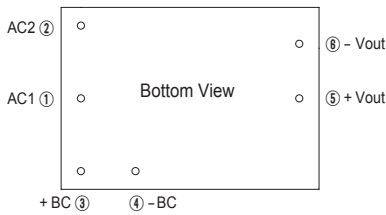

TUHS

Implementation • Mounting Method

Mounting method

- The unit can be mounted in any direction. When two or more power supplies are used side by side, position them with proper intervals to allow enough air ventilation. The temperature around each power supply should not exceed the temperature range shown in derating curve.
- Avoid placing the AC input line pattern layout underneath the unit. It will increase the line conducted noise. Make sure to leave an ample distance between the line pattern layout and the unit. Also avoid placing the DC output line pattern underneath the unit because it may increase the output noise. Lay out the pattern away from the unit.
- Avoid placing the signal line pattern layout underneath the unit because the power supply might become unstable. Lay out the pattern away from the unit.

Stress to the pins

- Applying excessive stress to the input or output pins of the power module may damage internal connections. Avoid applying stress in excess of that shown in right figure.
- Input/output pin are soldered to the PCB internally. Do not pull or bend a lead powerfully.
- If it is expected that stress is applied to the input/output pin due to vibration or impact, reduce the stress to the pin by taking such measures as fixing the unit to the PCB by silicone rubber, etc.

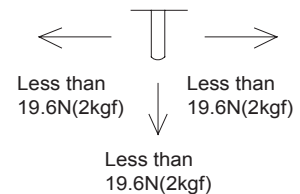

Soldering

- Flow soldering: 260°C for up to 15 seconds.
- Soldering iron (26W): 450°C for up to 5 seconds.

Derating

●Derating curve for input voltage

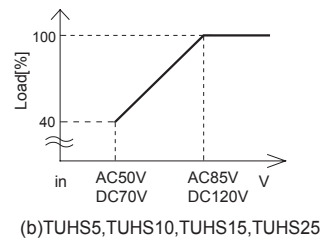
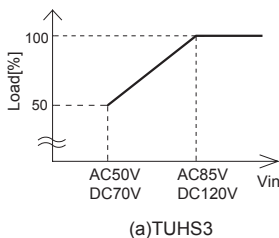

Derating

- TUHS3F Ambient temperature derating curve (Reference value)

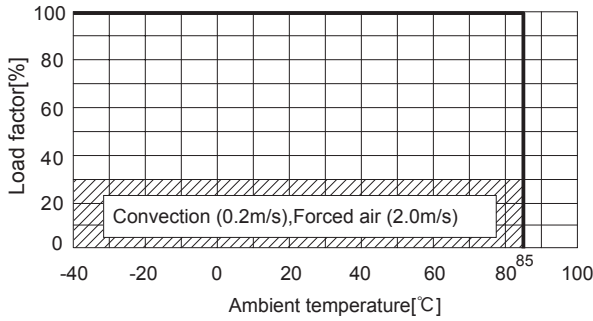

- TUHS5F Ambient temperature derating curve at convection cooling (Reference value)

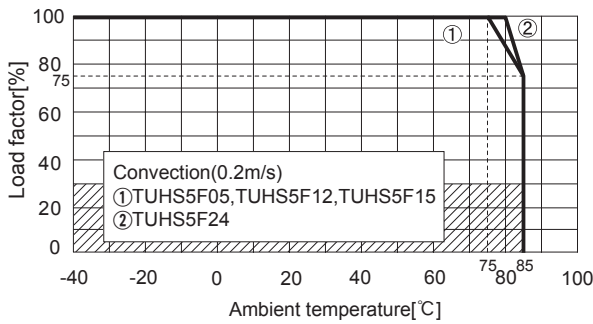

- TUHS5F Ambient temperature derating curve at forced air (Reference value)

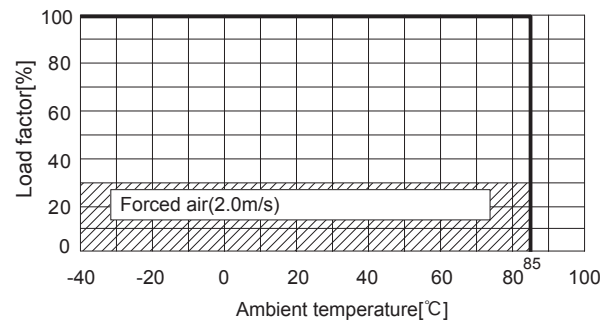

TUHS

- TUHS10F Ambient temperature derating curve at convection cooling (Reference value)

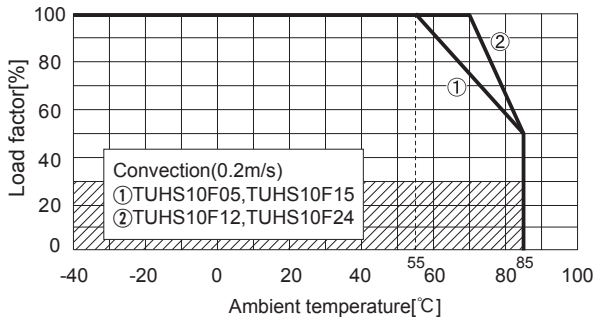

- TUHS10F Ambient temperature derating curve at forced air (Reference value)

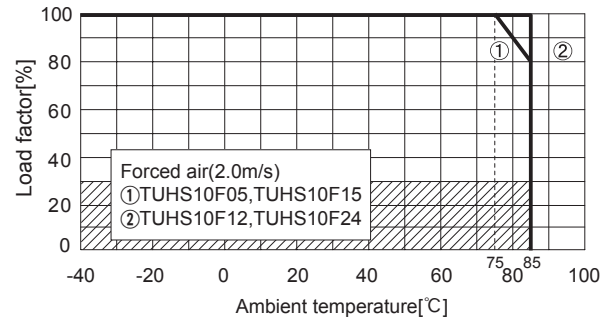

- TUHS15F Ambient temperature derating curve at convection cooling (Reference value)

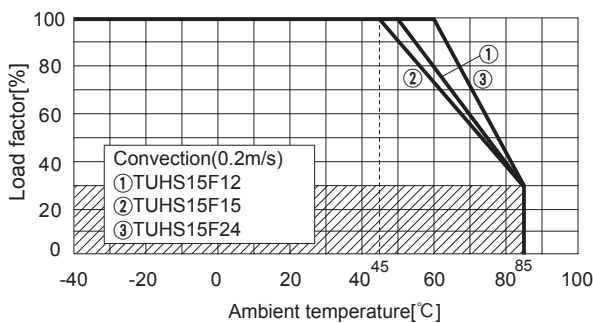

- TUHS15F Ambient temperature derating curve at forced air (Reference value)

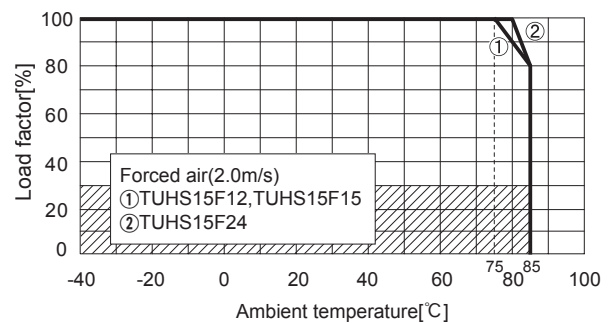

Derating

● TUHS25F Ambient temperature derating curve at convection cooling (Reference value)

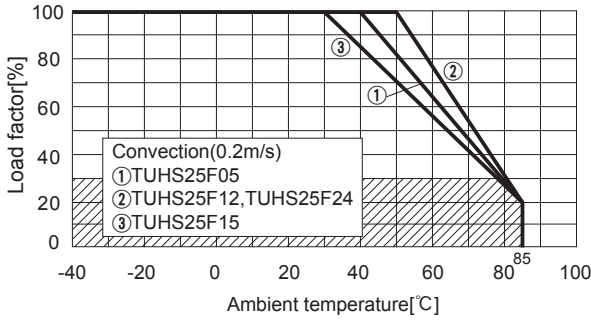

● TUHS25F Ambient temperature derating curve at forced air (Reference value)

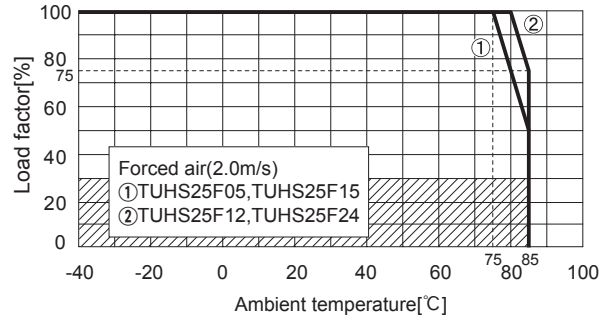

- Derating curve is shown below. Note: In the hatched area, the specification of Ripple, Ripple Noise is different from other area.
- Please have sufficient ventilation to keep the temperature of point A in Instruction Manual6. Please also make sure that the ambient temperature does not exceed 85C.

TUHS

Instruction Manual

- ◆ It is necessary to read the "Instruction Manual" and "Before using our product" before you use our product.

Instruction Manual <https://www.cosel.co.jp/redirect/catalog/en/TUHS/>
 Before using our product <https://en.cosel.co.jp/technical/caution/index.html>

TUHS



NOTICE



Basic Characteristics Data

Model	Circuit method	Switching frequency [kHz]	Input current [A]	Inrush current protection circuit	PCB/Pattern			Series/Parallel operation availability	
					Material	Single sided	Double sided	Series operation	Parallel operation
TUHS3F	Flyback converter	80-250 *3	*1	Resistor	glass fabric base,epoxy resin		Yes	Yes	*2
TUHS5F	Flyback converter	80-250 *3	*1	Resistor	glass fabric base,epoxy resin		Yes	Yes	*2
TUHS10F	Flyback converter	80-250 *3	*1	Resistor	glass fabric base,epoxy resin		Yes	Yes	*2
TUHS15F	Flyback converter	80-250 *3	*1	Resistor	glass fabric base,epoxy resin		Yes	Yes	*2
TUHS25F	Flyback converter	80-250 *3	*1	Thermistor	glass fabric base,epoxy resin		Yes	Yes	*2

*1 Refer to Specification.
 *2 Refer to instruction manual.
 *3 The value changes depending on input and load.



MG-series

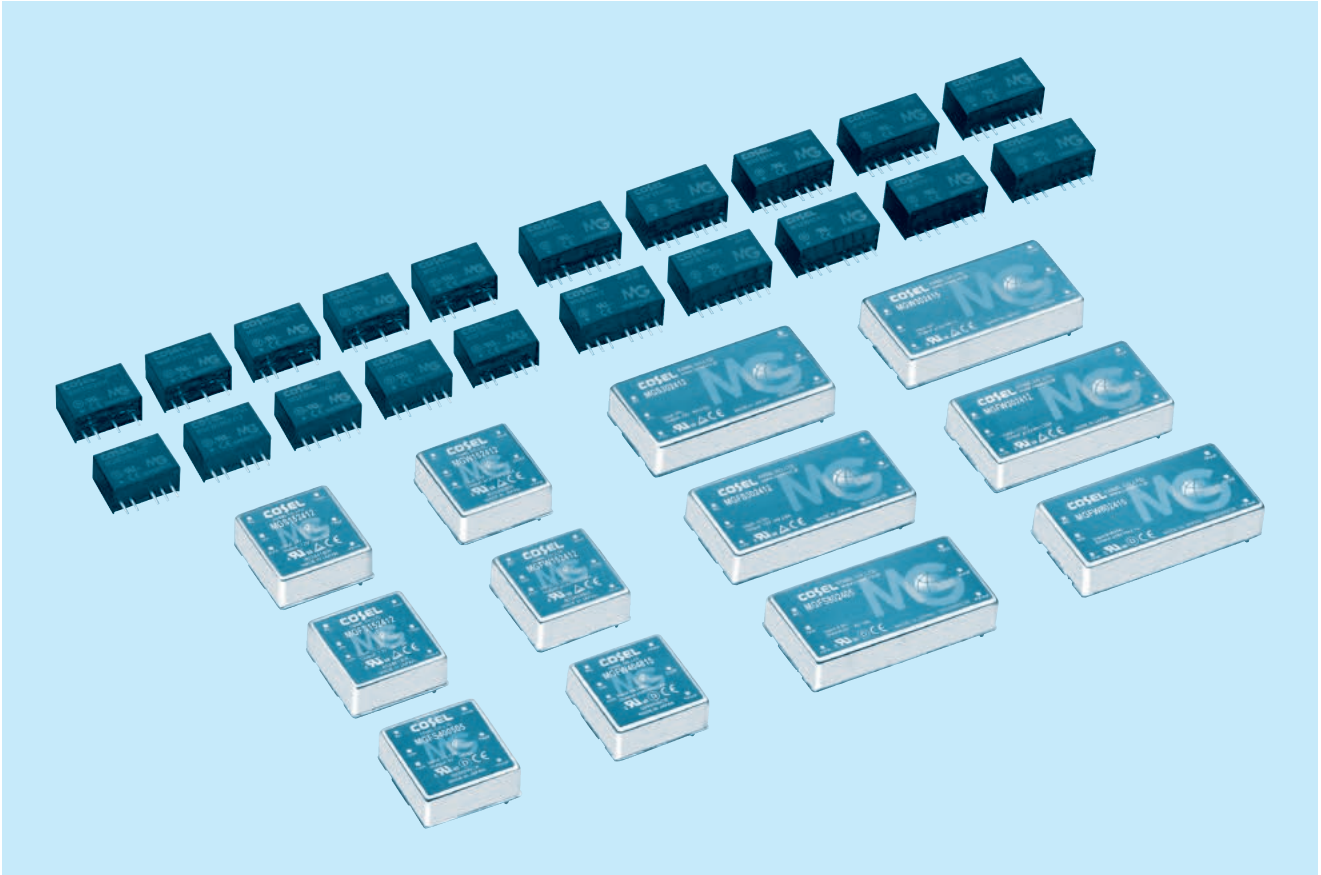

MG

Feature

- Industry Standard SIP6 (MG1R5/MG3), SIP8 (MG6/MG10), 1" X 1" (MG15/MG40), 1" X 2" (MG30/MG80)
- Wide input range DC4.5-13V/DC9-36V/DC18-76V (MGFS/MGFW)
- Ultra wide input range DC6-60V (MGXS/MGXW)
- High efficiency by synchronized rectification circuit (MGS10/MGFS10/MGS15/MGFS15/MGS30/MGFS30/MGFS40/MGFW40/MGFS80/MGFW80)
- 6 sided shield (MG15/MG30/MG40/MG80)
- I/O isolation voltage DC1,500V (1 minute)
- Built-in overcurrent protection circuits (recovers automatically)
- Built-in overvoltage protection circuits (MG30/MG40/MG80)
- Built-in remote ON/OFF (MG6/MG10/MG15/MG30/MG40/MG80)
- Output voltage adjustability by external variable resistor (MGS15/MGFS15/MGS30/MGFS30/MGFS40/MGFS80)
- High reliability : not built-in aluminum and tantalum electrolytic capacitor

CE marking

Low Voltage Directive
RoHS Directive

UKCA marking

Electrical Equipment Safety Regulations
RoHS Regulations

Safety agency approvals

UL60950-1, C-UL, EN62368-1 (MG1R5/MG3/MG6/MG10/MG15/MG30)
UL62368-1, C-UL, EN62368-1 (MG40/MG80)

10-year warranty

Refer to the instruction manual

MGS1R5

MG S 1R5 24 05 -□

① ② ③ ④ ⑤ ⑥

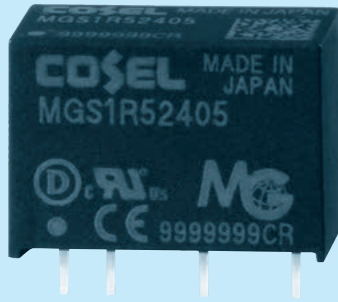

- ① Series name
- ② Single output
- ③ Output wattage
- ④ Input voltage
- ⑤ Output voltage
- ⑥ Optional
- Y2: Output voltage adjustable (+10%, -5%)

MODEL	MGS1R5053R3	MGS1R50505	MGS1R50512	MGS1R50515	MGS1R5123R3	MGS1R51205	MGS1R51212	MGS1R51215
MAX OUTPUT WATTAGE[W]	1.32	1.50	1.56	1.50	1.32	1.50	1.56	1.50
DC OUTPUT	VOLTAGE[V]	3.3	5	12	15	3.3	5	12
	CURRENT[A]	0.4	0.3	0.13	0.1	0.4	0.3	0.13

SPECIFICATIONS

	MODEL	MGS1R5053R3	MGS1R50505	MGS1R50512	MGS1R50515	MGS1R5123R3	MGS1R51205	MGS1R51212	MGS1R51215	
INPUT	VOLTAGE[V]	DC4.5 - 9 (Surge voltage 12.5V, 100ms max)				DC9 - 18 (Surge voltage 25V, 100ms max)				
	CURRENT[A]	*1 0.33typ	0.37typ	0.37typ	0.36typ	0.14typ	0.15typ	0.16typ	0.15typ	
	EFFICIENCY[%]	*1 80typ	82typ	85typ	84typ	80typ	83typ	84typ	84typ	
OUTPUT	VOLTAGE[V]	3.3	5	12	15	3.3	5	12	15	
	CURRENT[A]	0.4	0.3	0.13	0.1	0.4	0.3	0.13	0.1	
	LINE REGULATION[mV]	20max	20max	48max	60max	20max	20max	48max	60max	
	LOAD REGULATION[mV]	20max	20max	48max	60max	20max	20max	48max	60max	
	RIPPLE[mVp-p]	*2 120max	120max	150max	150max	120max	120max	150max	150max	
	RIPPLE NOISE[mVp-p]	*2 200max	200max	200max	200max	200max	200max	200max	200max	
	TEMPERATURE REGULATION[mV]	-20 to +85°C	50max	50max	150max	180max	50max	50max	150max	180max
		-40 to +85°C	80max	80max	240max	290max	80max	80max	240max	290max
	DRIFT[mV]	*3 20max	20max	48max	60max	20max	20max	48max	60max	
	START-UP TIME[ms]	30max (Minimum input, I _o =100%)								
OUTPUT VOLTAGE SETTING[V]	3.21 - 3.42	4.90 - 5.21	11.64 - 12.36	14.55 - 15.45	3.21 - 3.42	4.90 - 5.21	11.64 - 12.36	14.55 - 15.45		
PROTECTION CIRCUIT	OVERCURRENT PROTECTION	Works over 105% of rating and recovers automatically								

MODEL	MGS1R5243R3	MGS1R52405	MGS1R52412	MGS1R52415	MGS1R5483R3	MGS1R54805	MGS1R54812	MGS1R54815
MAX OUTPUT WATTAGE[W]	1.32	1.50	1.56	1.50	1.32	1.50	1.56	1.50
DC OUTPUT	VOLTAGE[V]	3.3	5	12	15	3.3	5	12
	CURRENT[A]	0.4	0.3	0.13	0.1	0.4	0.3	0.13

SPECIFICATIONS

	MODEL	MGS1R5243R3	MGS1R52405	MGS1R52412	MGS1R52415	MGS1R5483R3	MGS1R54805	MGS1R54812	MGS1R54815	
INPUT	VOLTAGE[V]	DC18 - 36 (Surge voltage 50V, 100ms max)				DC36 - 76 (Surge voltage 100V, 100ms max)				
	CURRENT[A]	*1 0.071typ	0.079typ	0.080typ	0.077typ	0.036typ	0.040typ	0.040typ	0.039typ	
	EFFICIENCY[%]	*1 78typ	80typ	82typ	82typ	77typ	80typ	82typ	82typ	
OUTPUT	VOLTAGE[V]	3.3	5	12	15	3.3	5	12	15	
	CURRENT[A]	0.4	0.3	0.13	0.1	0.4	0.3	0.13	0.1	
	LINE REGULATION[mV]	20max	20max	48max	60max	20max	20max	48max	60max	
	LOAD REGULATION[mV]	20max	20max	48max	60max	20max	20max	48max	60max	
	RIPPLE[mVp-p]	*2 120max	120max	150max	150max	120max	120max	150max	150max	
	RIPPLE NOISE[mVp-p]	*2 200max	200max	200max	200max	200max	200max	200max	200max	
	TEMPERATURE REGULATION[mV]	-20 to +85°C	50max	50max	150max	180max	50max	50max	150max	180max
		-40 to +85°C	80max	80max	240max	290max	80max	80max	240max	290max
	DRIFT[mV]	*3 20max	20max	48max	60max	20max	20max	48max	60max	
	START-UP TIME[ms]	30max (Minimum input, I _o =100%)								
OUTPUT VOLTAGE SETTING[V]	3.21 - 3.42	4.90 - 5.21	11.64 - 12.36	14.55 - 15.45	3.21 - 3.42	4.90 - 5.21	11.64 - 12.36	14.55 - 15.45		
PROTECTION CIRCUIT	OVERCURRENT PROTECTION	Works over 105% of rating and recovers automatically								

GENERAL SPECIFICATIONS

ISOLATION	INPUT-OUTPUT	DC1,500V or AC1,000V 1minute, Cutoff current=10mA, DC500V 1,000MΩ min (20±15°C)
ENVIRONMENT	OPERATING TEMP.,HUMID.AND ALTITUDE	-40 to +85°C, 20 to 95%RH (Non condensing) (Refer to "Derating"), 5,000m (16,400feet) max
	STORAGE TEMP.,HUMID.AND ALTITUDE	-40 to +100°C, 20 to 95%RH (Non condensing), 9,000m (30,000feet) max
	VIBRATION	10 - 55Hz 98.0m/s ² (10G), 3minute period, 60minutes each along X, Y and Z axis
	IMPACT	490.3m/s ² (50G) 11ms, once each along X, Y and Z axis
SAFETY	AGENCY APPROVALS	UL60950-1, C-UL, EN62368-1
OTHERS	CASE SIZE/WEIGHT	17.0×12.0×8.5mm [0.67×0.48×0.34 inches] (W×H×D) / 4g max
	COOLING METHOD	Convection/Forced air

- *1 Rated input 5V, 12V, 24V or 48V DC I_o=100%
- *2 Ripple and ripple noise is measured by using test board with ceramic capacitor 1μF at 50mm from output pins.
- *3 Drift is the DC output accuracy for eight hours period after a half-hour warm-up at 25°C.
- * Parallel operation with other model is not possible.
- * MGW1R5xx12/MGW1R5xx15 is available as single output, +24V/+30V

External view

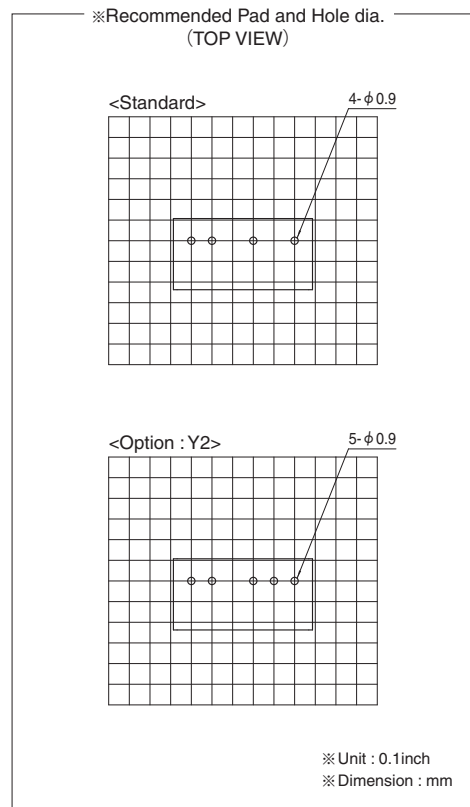
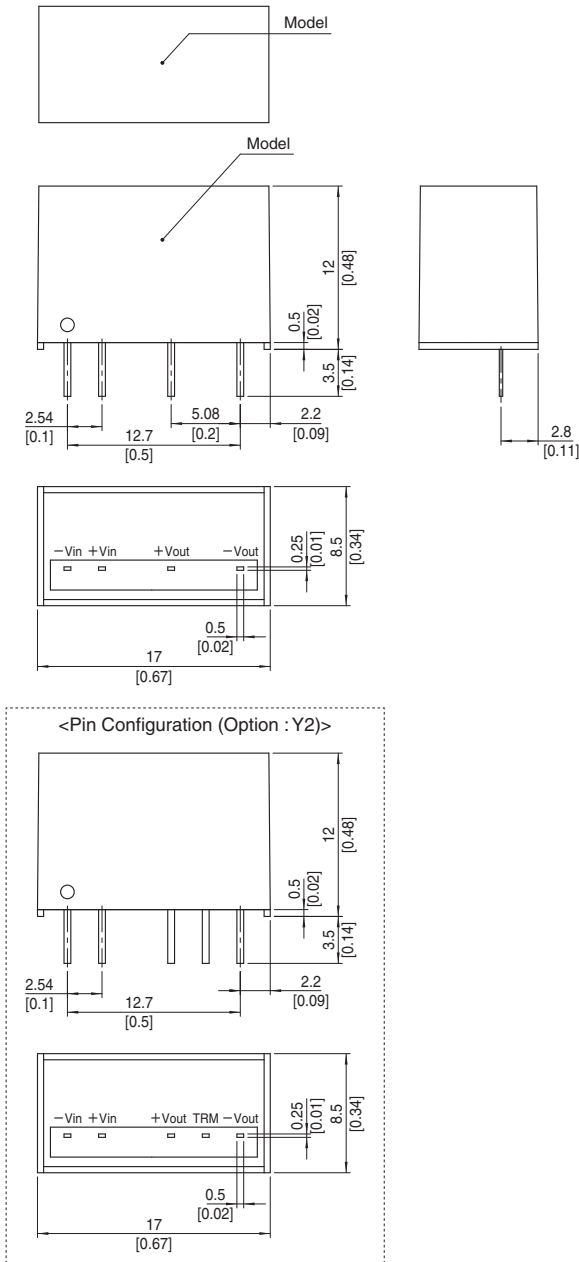

- ※ Unit : 0.1inch
- ※ Dimension : mm
- ※ Tolerance ±0.5 [±0.02]
- ※ Dimensions in mm, []= inches
- ※ Pin terminal material : Copper
- ※ Planting treatment of terminal : Lead free plating
- ※ Case material : PBT
- ※ Weight 4g max

MG

MGW1R5

MG W 1R5 24 12 -□

① ② ③ ④ ⑤ ⑥

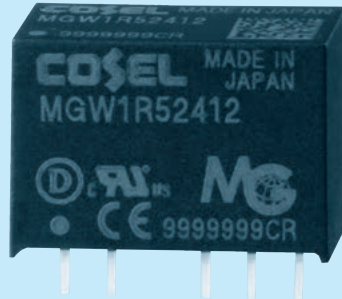

- ① Series name
- ② Dual output
- ③ Output wattage
- ④ Input voltage
- ⑤ Output voltage
- ⑥ Optional

MODEL	MGW1R50512	MGW1R50515	MGW1R51212	MGW1R51215	MGW1R52412	MGW1R52415	MGW1R54812	MGW1R54815
MAX OUTPUT WATTAGE[W]	1.56	1.50	1.56	1.50	1.56	1.50	1.56	1.50
DC OUTPUT	VOLTAGE[V] *1	±12 or +24	±15 or +30	±12 or +24	±15 or +30	±12 or +24	±15 or +30	±12 or +24
	CURRENT[A]	0.065	0.05	0.065	0.05	0.065	0.05	0.065

SPECIFICATIONS

	MODEL	MGW1R50512	MGW1R50515	MGW1R51212	MGW1R51215	MGW1R52412	MGW1R52415	MGW1R54812	MGW1R54815	
INPUT	VOLTAGE[V]	DC4.5 - 9 (Surge voltage 12.5V, 100ms max)		DC9 - 18 (Surge voltage 25V, 100ms max)		DC18 - 36 (Surge voltage 50V, 100ms max)		DC36 - 76 (Surge voltage 100V, 100ms max)		
	CURRENT[A] *2	0.38typ	0.38typ	0.16typ	0.16typ	0.080typ	0.079typ	0.041typ	0.040typ	
	EFFICIENCY[%] *2	83typ	81typ	83typ	81typ	82typ	80typ	81typ	80typ	
OUTPUT	VOLTAGE[V]	±12 or +24	±15 or +30	±12 or +24	±15 or +30	±12 or +24	±15 or +30	±12 or +24	±15 or +30	
	CURRENT[A]	0.065	0.05	0.065	0.05	0.065	0.05	0.065	0.05	
	LINE REGULATION[mV]	60max	75max	60max	75max	60max	75max	60max	75max	
	LOAD REGULATION[mV]	*3	480max	600max	480max	600max	480max	600max	480max	600max
		*4	600max	750max	600max	750max	600max	750max	600max	750max
	RIPPLE[mVp-p] *5	150max	150max	150max	150max	150max	150max	150max	150max	
	RIPPLE NOISE[mVp-p] *5	200max	200max	200max	200max	200max	200max	200max	200max	
	TEMPERATURE REGULATION[mV]	-20 to +85°C	210max	260max	210max	260max	210max	260max	210max	260max
		-40 to +85°C	320max	390max	320max	390max	320max	390max	320max	390max
	DRIFT[mV] *6	48max	60max	48max	60max	48max	60max	48max	60max	
START-UP TIME[ms]	30max (Minimum input, I _o =100%)									
OUTPUT VOLTAGE SETTING[V]	11.64 - 12.36	14.55 - 15.45	11.64 - 12.36	14.55 - 15.45	11.64 - 12.36	14.55 - 15.45	11.64 - 12.36	14.55 - 15.45		
PROTECTION CIRCUIT	OVERCURRENT PROTECTION	Works over 105% of rating and recovers automatically								
ISOLATION	INPUT-OUTPUT	DC1,500V or AC1,000V 1minute, Cutoff current=10mA, DC500V 1,000MΩ min (20±15°C)								
ENVIRONMENT	OPERATING TEMP., HUMID. AND ALTITUDE	-40 to +85°C, 20 to 95%RH (Non condensing) (Refer to "Derating"), 5,000m (16,400feet) max								
	STORAGE TEMP., HUMID. AND ALTITUDE	-40 to +100°C, 20 to 95%RH (Non condensing), 9,000m (30,000feet) max								
	VIBRATION	10 - 55Hz 98.0m/s ² (10G), 3minute period, 60minutes each along X, Y and Z axis								
	IMPACT	490.3m/s ² (50G) 11ms, once each along X, Y and Z axis								
SAFETY	AGENCY APPROVALS	UL60950-1, C-UL, EN62368-1								
OTHERS	CASE SIZE/WEIGHT	17.0 × 12.0 × 8.5mm [0.67 × 0.48 × 0.34 inches] (W × H × D) / 4g max								
	COOLING METHOD	Convection/Forced air								

*1 Single output +24V, +30V with no use of COM.
 *2 Rated input 5V, 12V, 24V or 48V DC I_o=100%
 *3 Symmetrical loading from 20% to 100%.
 *4 Symmetrical loading from 0% to 100%.
 *5 Ripple and Ripple Noise is measured by using test board with ceramic capacitor 1μF at 50mm from output pins. (20MHz Oscilloscope)
 *6 Drift is the DC output accuracy for eight hours period after a half-hour warm-up at 25°C.
 * Parallel operation with other model is not possible.

External view

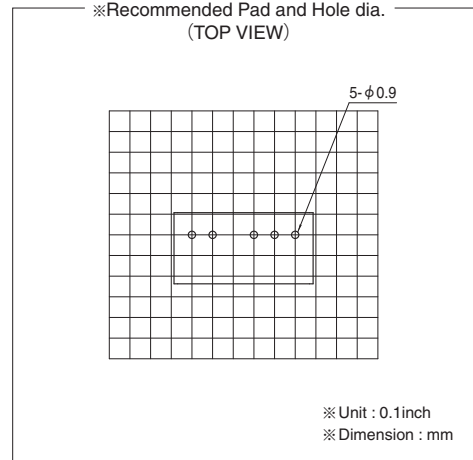
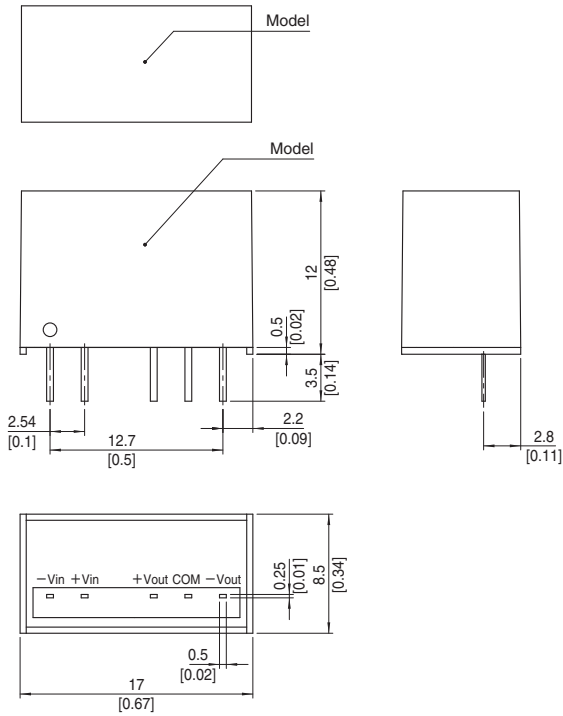

- ※ Tolerance ± 0.5 [± 0.02]
- ※ Dimensions in mm, []= inches
- ※ Pin terminal material : Copper
- ※ Plating treatment of terminal : Lead free plating
- ※ Case material : PBT
- ※ Weight 4g max

MG

MGS3

MG S 3 24 05 -□

① ② ③ ④ ⑤ ⑥

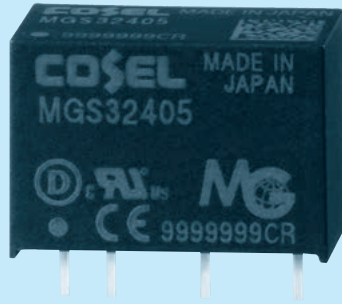

- ① Series name
- ② Single output
- ③ Output wattage
- ④ Input voltage
- ⑤ Output voltage
- ⑥ Optional
- Y2: Output voltage adjustable (+10%, -5%)

MODEL	MGS3053R3	MGS30505	MGS30512	MGS30515	MGS3123R3	MGS31205	MGS31212	MGS31215
MAX OUTPUT WATTAGE[W]	2.64	3.0	3.0	3.0	2.64	3.0	3.0	3.0
DC OUTPUT	VOLTAGE[V]	3.3	5	12	15	3.3	5	12
	CURRENT[A]	0.8	0.6	0.25	0.2	0.8	0.6	0.25

SPECIFICATIONS

	MODEL	MGS3053R3	MGS30505	MGS30512	MGS30515	MGS3123R3	MGS31205	MGS31212	MGS31215
INPUT	VOLTAGE[V]	DC4.5 - 9 (Surge voltage 12.5V, 100ms max)				DC9 - 18 (Surge voltage 25V, 100ms max)			
	CURRENT[A]	*1 0.67typ	0.73typ	0.71typ	0.71typ	0.28typ	0.30typ	0.29typ	0.30typ
	EFFICIENCY[%]	*1 79typ	82typ	85typ	85typ	80typ	83typ	86typ	85typ
OUTPUT	VOLTAGE[V]	3.3	5	12	15	3.3	5	12	15
	CURRENT[A]	0.8	0.6	0.25	0.2	0.8	0.6	0.25	0.2
	LINE REGULATION[mV]	20max	20max	48max	60max	20max	20max	48max	60max
	LOAD REGULATION[mV]	20max	20max	48max	60max	20max	20max	48max	60max
	RIPPLE[mVp-p]	*2 120max	120max	150max	150max	120max	120max	150max	150max
	RIPPLE NOISE[mVp-p]	*2 200max	200max	200max	200max	200max	200max	200max	200max
	TEMPERATURE REGULATION[mV]	-20 to +75°C 50max	50max	150max	180max	50max	50max	150max	180max
		-40 to +75°C 80max	80max	240max	290max	80max	80max	240max	290max
	DRIFT[mV]	*3 20max	20max	48max	60max	20max	20max	48max	60max
	START-UP TIME[ms]	30max (Minimum input, I _o =100%)							
PROTECTION CIRCUIT	OVERCURRENT PROTECTION	Works over 105% of rating and recovers automatically							

MODEL	MGS3243R3	MGS32405	MGS32412	MGS32415	MGS3483R3	MGS34805	MGS34812	MGS34815
MAX OUTPUT WATTAGE[W]	2.64	3.0	3.0	3.0	2.64	3.0	3.0	3.0
DC OUTPUT	VOLTAGE[V]	3.3	5	12	15	3.3	5	12
	CURRENT[A]	0.8	0.6	0.25	0.2	0.8	0.6	0.25

SPECIFICATIONS

	MODEL	MGS3243R3	MGS32405	MGS32412	MGS32415	MGS3483R3	MGS34805	MGS34812	MGS34815
INPUT	VOLTAGE[V]	DC18 - 36 (Surge voltage 50V, 100ms max)				DC36 - 76 (Surge voltage 100V, 100ms max)			
	CURRENT[A]	*1 0.14typ	0.15typ	0.15typ	0.15typ	0.071typ	0.079typ	0.074typ	0.074typ
	EFFICIENCY[%]	*1 80typ	82typ	85typ	85typ	78typ	80typ	85typ	85typ
OUTPUT	VOLTAGE[V]	3.3	5	12	15	3.3	5	12	15
	CURRENT[A]	0.8	0.6	0.25	0.2	0.8	0.6	0.25	0.2
	LINE REGULATION[mV]	20max	20max	48max	60max	20max	20max	48max	60max
	LOAD REGULATION[mV]	20max	20max	48max	60max	20max	20max	48max	60max
	RIPPLE[mVp-p]	*2 120max	120max	150max	150max	120max	120max	150max	150max
	RIPPLE NOISE[mVp-p]	*2 200max	200max	200max	200max	200max	200max	200max	200max
	TEMPERATURE REGULATION[mV]	-20 to +75°C 50max	50max	150max	180max	50max	50max	150max	180max
		-40 to +75°C 80max	80max	240max	290max	80max	80max	240max	290max
	DRIFT[mV]	*3 20max	20max	48max	60max	20max	20max	48max	60max
	START-UP TIME[ms]	30max (Minimum input, I _o =100%)							
PROTECTION CIRCUIT	OVERCURRENT PROTECTION	Works over 105% of rating and recovers automatically							

GENERAL SPECIFICATIONS

ISOLATION	INPUT-OUTPUT	DC1,500V or AC1,000V 1minute, Cutoff current=10mA, DC500V 1,000MΩ min (20±15°C)
ENVIRONMENT	OPERATING TEMP.,HUMID.AND ALTITUDE	-40 to +85°C, 20 to 95%RH (Non condensing) (Refer to "Derating"), 5,000m (16,400feet) max
	STORAGE TEMP.,HUMID.AND ALTITUDE	-40 to +100°C, 20 to d95%RH (Non condensing), 9,000m (30,000feet) max
	VIBRATION	10 - 55Hz 98.0m/s ² (10G), 3minute period, 60minutes each along X, Y and Z axis
	IMPACT	490.3m/s ² (50G) 11ms, once each along X, Y and Z axis
SAFETY	AGENCY APPROVALS	UL60950-1, C-UL, EN62368-1
OTHERS	CASE SIZE/WEIGHT	17.0×12.0×8.5mm [0.67×0.48×0.34 inches] (W×H×D) / 4g max
	COOLING METHOD	Convection/Forced air

- *1 Rated input 5V, 12V, 24V or 48V DC I_o=100%
- *2 Ripple and ripple noise is measured by using test board with ceramic capacitor 1μF at 50mm from output pins.
- *3 Drift is the DC output accuracy for eight hours period after a half-hour warm-up at 25°C.
- * Parallel operation with other model is not possible.
- * MGW3xx12/MGW3xx15 is available as single output, +24V/+30V

External view

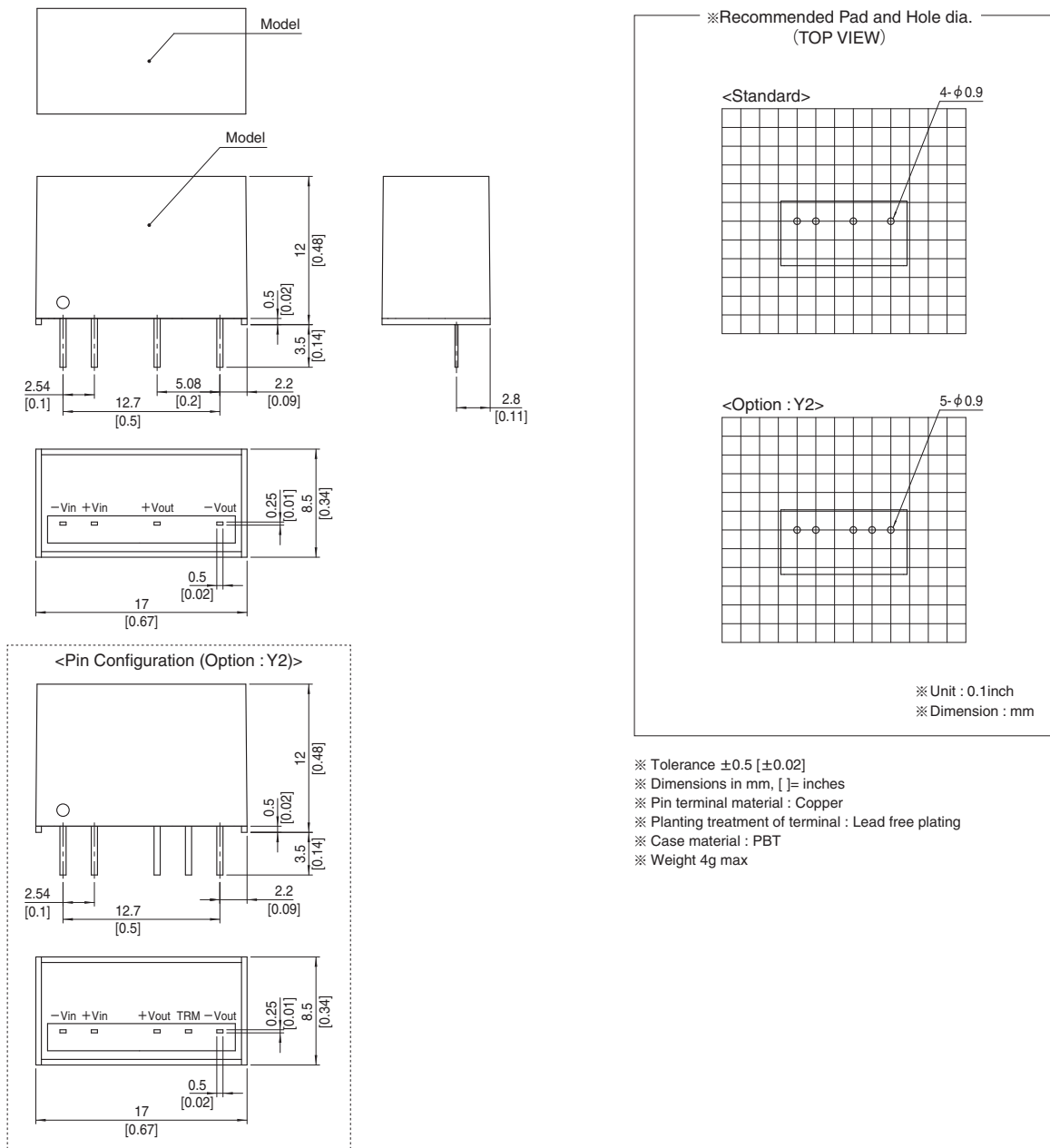

- ※ Tolerance ±0.5 [±0.02]
- ※ Dimensions in mm, []= inches
- ※ Pin terminal material : Copper
- ※ Planting treatment of terminal : Lead free plating
- ※ Case material : PBT
- ※ Weight 4g max

MGW3

MG W 3 24 12 - □

① ② ③ ④ ⑤ ⑥

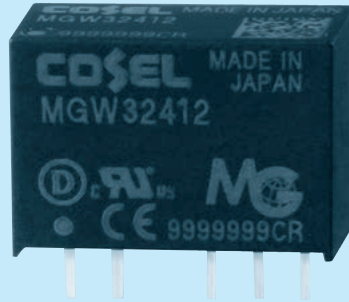

- ① Series name
- ② Dual output
- ③ Output wattage
- ④ Input voltage
- ⑤ Output voltage
- ⑥ Optional

MODEL	MGW30512	MGW30515	MGW31212	MGW31215	MGW32412	MGW32415	MGW34812	MGW34815
MAX OUTPUT WATTAGE[W]	3.12	3.00	3.12	3.00	3.12	3.00	3.12	3.00
DC OUTPUT	VOLTAGE[V] *1	±12 or +24	±15 or +30	±12 or +24	±15 or +30	±12 or +24	±15 or +30	±12 or +24
	CURRENT[A]	0.13	0.1	0.13	0.1	0.13	0.1	0.13

SPECIFICATIONS

	MODEL	MGW30512	MGW30515	MGW31212	MGW31215	MGW32412	MGW32415	MGW34812	MGW34815	
INPUT	VOLTAGE[V]	DC4.5 - 9 (Surge voltage 12.5V, 100ms max)		DC9 - 18 (Surge voltage 25V, 100ms max)		DC18 - 36 (Surge voltage 50V, 100ms max)		DC36 - 76 (Surge voltage 100V, 100ms max)		
	CURRENT[A] *2	0.76typ	0.74typ	0.31typ	0.31typ	0.16typ	0.16typ	0.080typ	0.077typ	
	EFFICIENCY[%] *2	83typ	82typ	84typ	83typ	83typ	83typ	82typ	82typ	
OUTPUT	VOLTAGE[V]	±12 or +24	±15 or +30	±12 or +24	±15 or +30	±12 or +24	±15 or +30	±12 or +24	±15 or +30	
	CURRENT[A]	0.13	0.1	0.13	0.1	0.13	0.1	0.13	0.1	
	LINE REGULATION[mV]	60max	75max	60max	75max	60max	75max	60max	75max	
	LOAD REGULATION[mV]	*3	480max	600max	480max	600max	480max	600max	480max	600max
		*4	600max	750max	600max	750max	600max	750max	600max	750max
	RIPPLE[mVp-p] *5	150max	150max	150max	150max	150max	150max	150max	150max	
	RIPPLE NOISE[mVp-p] *5	200max	200max	200max	200max	200max	200max	200max	200max	
	TEMPERATURE REGULATION[mV]	-20 to +70°C	180max	220max	180max	220max	180max	220max	180max	220max
		-40 to +70°C	290max	340max	290max	340max	290max	340max	290max	340max
	DRIFT[mV] *6	48max	60max	48max	60max	48max	60max	48max	60max	
START-UP TIME[ms]	30max (Minimum input, I _o =100%)									
OUTPUT VOLTAGE SETTING[V]	11.64 - 12.36	14.55 - 15.45	11.64 - 12.36	14.55 - 15.45	11.64 - 12.36	14.55 - 15.45	11.64 - 12.36	14.55 - 15.45		
PROTECTION CIRCUIT	OVERCURRENT PROTECTION	Works over 105% of rating and recovers automatically								
ISOLATION	INPUT-OUTPUT	DC1,500V or AC1,000V 1minute, Cutoff current=10mA, DC500V 1,000MΩ min (20±15°C)								
ENVIRONMENT	OPERATING TEMP., HUMID. AND ALTITUDE	-40 to +85°C, 20 to 95%RH (Non condensing) (Refer to "Derating"), 5,000m (16,400feet) max								
	STORAGE TEMP., HUMID. AND ALTITUDE	-40 to +100°C, 20 to 95%RH (Non condensing), 9,000m (30,000feet) max								
	VIBRATION	10 - 55Hz 98.0m/s ² (10G), 3minute period, 60minutes each along X, Y and Z axis								
	IMPACT	490.3m/s ² (50G) 11ms, once each along X, Y and Z axis								
SAFETY	AGENCY APPROVALS	UL60950-1, C-UL, EN62368-1								
OTHERS	CASE SIZE/WEIGHT	17.0 X 12.0 X 8.5mm [0.67 X 0.48 X 0.34 inches] (W X H X D) / 4g max								
	COOLING METHOD	Convection/Forced air								

- *1 Single output +24V, +30V with no use of COM.
- *2 Rated input 5V, 12V, 24V or 48V DC I_o=100%
- *3 Symmetrical loading from 20% to 100%.
- *4 Symmetrical loading from 0% to 100%.
- *5 Ripple and Ripple Noise is measured by using test board with ceramic capacitor 1μF at 50mm from output pins. (20MHz Oscilloscope)
- *6 Drift is the DC output accuracy for eight hours period after a half-hour warm-up at 25°C.
- * Parallel operation with other model is not possible.

External view

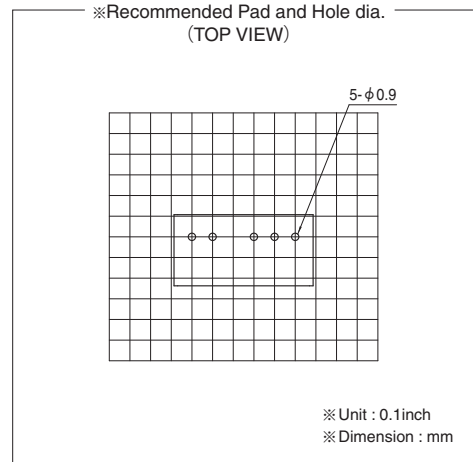
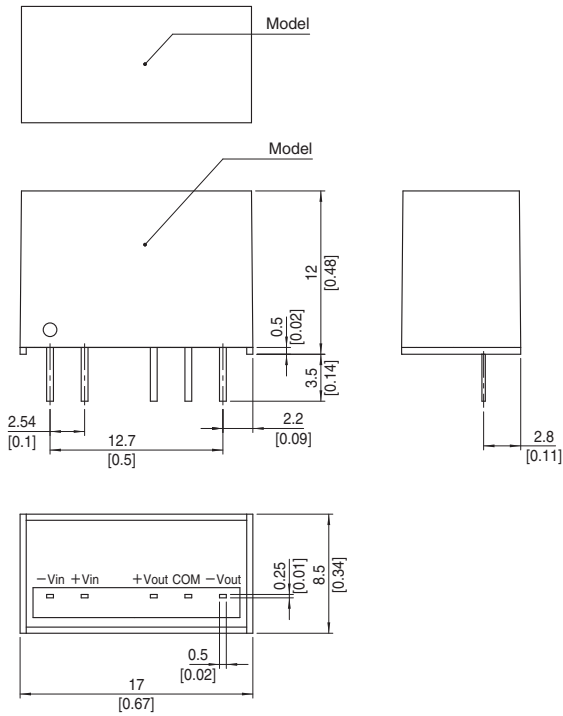

- ※ Tolerance ± 0.5 [± 0.02]
- ※ Dimensions in mm, []= inches
- ※ Pin terminal material : Copper
- ※ Plating treatment of terminal : Lead free plating
- ※ Case material : PBT
- ※ Weight 4g max

MG

MGS6

MG S 6 24 05 - □

① ② ③ ④ ⑤ ⑥

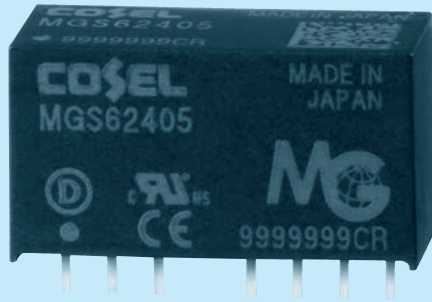

- ① Series name
- ② Single output
- ③ Output wattage
- ④ Input voltage
- ⑤ Output voltage
- ⑥ Optional
- Y2: Output voltage adjustable (+10%, -5%)

MODEL	MGS6053R3	MGS60505	MGS60512	MGS60515	MGS6123R3	MGS61205	MGS61212	MGS61215
MAX OUTPUT WATTAGE[W]	5.28	6.0	6.0	6.0	5.28	6.0	6.0	6.0
DC OUTPUT	VOLTAGE[V]	3.3	5	12	15	3.3	5	12
	CURRENT[A]	1.6	1.2	0.5	0.4	1.6	1.2	0.5

SPECIFICATIONS

	MODEL	MGS6053R3	MGS60505	MGS60512	MGS60515	MGS6123R3	MGS61205	MGS61212	MGS61215	
INPUT	VOLTAGE[V]	DC4.5 - 9 (Surge voltage 12.5V, 100ms max)				DC9 - 18 (Surge voltage 25V, 100ms max)				
	CURRENT[A]	*1 1.31typ	1.42typ	1.37typ	1.37typ	0.54typ	0.59typ	0.57typ	0.57typ	
	EFFICIENCY[%]	*1 81typ	85typ	88typ	88typ	82typ	85typ	89typ	89typ	
OUTPUT	VOLTAGE[V]	3.3	5	12	15	3.3	5	12	15	
	CURRENT[A]	1.6	1.2	0.5	0.4	1.6	1.2	0.5	0.4	
	LINE REGULATION[mV]	20max	20max	48max	60max	20max	20max	48max	60max	
	LOAD REGULATION[mV]	20max	20max	48max	60max	20max	20max	48max	60max	
	RIPPLE[mVp-p]	lo=30% -	75max	75max	100max	100max	75max	75max	100max	100max
		lo=0 - 30%	225max	225max	300max	300max	225max	225max	300max	300max
	RIPPLE NOISE[mVp-p]	lo=30% -	120max	120max	150max	150max	120max	120max	150max	150max
		lo=0 - 30%	300max	300max	400max	400max	300max	300max	400max	400max
	TEMPERATURE REGULATION[mV]	-20 to +70°C	50max	50max	150max	180max	50max	50max	150max	180max
		-40 to +70°C	80max	80max	240max	290max	80max	80max	240max	290max
DRIFT[mV]	*3 20max	20max	48max	60max	20max	20max	48max	60max		
START-UP TIME[ms]	30max (Minimum input, lo=100%)									
OUTPUT VOLTAGE SETTING[V]	3.21 - 3.42	4.90 - 5.21	11.64 - 12.36	14.55 - 15.45	3.21 - 3.42	4.90 - 5.21	11.64 - 12.36	14.55 - 15.45		
PROTECTION CIRCUIT AND OTHERS	OVERCURRENT PROTECTION	Works over 105% of rating and recovers automatically								
	REMOTE ON/OFF	Provided (Negative logic L : ON, H : OFF)								

MODEL	MGS6243R3	MGS62405	MGS62412	MGS62415	MGS6483R3	MGS64805	MGS64812	MGS64815
MAX OUTPUT WATTAGE[W]	5.28	6.0	6.0	6.0	5.28	6.0	6.0	6.0
DC OUTPUT	VOLTAGE[V]	3.3	5	12	15	3.3	5	12
	CURRENT[A]	1.6	1.2	0.5	0.4	1.6	1.2	0.5

SPECIFICATIONS

	MODEL	MGS6243R3	MGS62405	MGS62412	MGS62415	MGS6483R3	MGS64805	MGS64812	MGS64815	
INPUT	VOLTAGE[V]	DC18 - 36 (Surge voltage 50V, 100ms max)				DC36 - 76 (Surge voltage 100V, 100ms max)				
	CURRENT[A]	*1 0.27typ	0.30typ	0.29typ	0.29typ	0.14typ	0.15typ	0.15typ	0.15typ	
	EFFICIENCY[%]	*1 82typ	85typ	89typ	89typ	81typ	85typ	89typ	89typ	
OUTPUT	VOLTAGE[V]	3.3	5	12	15	3.3	5	12	15	
	CURRENT[A]	1.6	1.2	0.5	0.4	1.6	1.2	0.5	0.4	
	LINE REGULATION[mV]	20max	20max	48max	60max	20max	20max	48max	60max	
	LOAD REGULATION[mV]	20max	20max	48max	60max	20max	20max	48max	60max	
	RIPPLE[mVp-p]	lo=30% -	75max	75max	100max	100max	75max	75max	100max	100max
		lo=0 - 30%	225max	225max	300max	300max	225max	225max	300max	300max
	RIPPLE NOISE[mVp-p]	lo=30% -	120max	120max	150max	150max	120max	120max	150max	150max
		lo=0 - 30%	300max	300max	400max	400max	300max	300max	400max	400max
	TEMPERATURE REGULATION[mV]	-20 to +70°C	50max	50max	150max	180max	50max	50max	150max	180max
		-40 to +70°C	80max	80max	240max	290max	80max	80max	240max	290max
DRIFT[mV]	*3 20max	20max	48max	60max	20max	20max	48max	60max		
START-UP TIME[ms]	30max (Minimum input, lo=100%)									
OUTPUT VOLTAGE SETTING[V]	3.21 - 3.42	4.90 - 5.21	11.64 - 12.36	14.55 - 15.45	3.21 - 3.42	4.90 - 5.21	11.64 - 12.36	14.55 - 15.45		
PROTECTION CIRCUIT AND OTHERS	OVERCURRENT PROTECTION	Works over 105% of rating and recovers automatically								
	REMOTE ON/OFF	Provided (Negative logic L : ON, H : OFF)								

GENERAL SPECIFICATIONS

ISOLATION	INPUT-OUTPUT	DC1,500V or AC1,000V 1minute, Cutoff current=10mA, DC500V 1,000MΩ min (20±15°C)
ENVIRONMENT	OPERATING TEMP., HUMID. AND ALTITUDE	-40 to +85°C, 20 to 95%RH (Non condensing) (Refer to "Derating"), 5,000m (16,400feet) max
	STORAGE TEMP., HUMID. AND ALTITUDE	-40 to +100°C, 20 to 95%RH (Non condensing), 9,000m (30,000feet) max
	VIBRATION	10 - 55Hz 98.0m/s ² (10G), 3minute period, 60minutes each along X, Y and Z axis
	IMPACT	490.3m/s ² (50G) 11ms, once each along X, Y and Z axis
SAFETY	AGENCY APPROVALS	UL60950-1, C-UL, EN62368-1
OTHERS	CASE SIZE/WEIGHT	22.0×12.0×9.5mm [0.87×0.48×0.38 inches] (W×H×D) / 7g max
	COOLING METHOD	Convection/Forced air

- *1 Rated input 5V, 12V, 24V or 48V DC I_o=100%
- *2 Ripple and ripple noise is measured by using test board with ceramic capacitor 1μF at 50mm from output pins.
- *3 Drift is the DC output accuracy for eight hours period after a half-hour warm-up at 25°C.
- * Parallel operation with other model is not possible.
- * MGW6xx12/MGW6xx15 is available as single output, +24V/+30V

External view

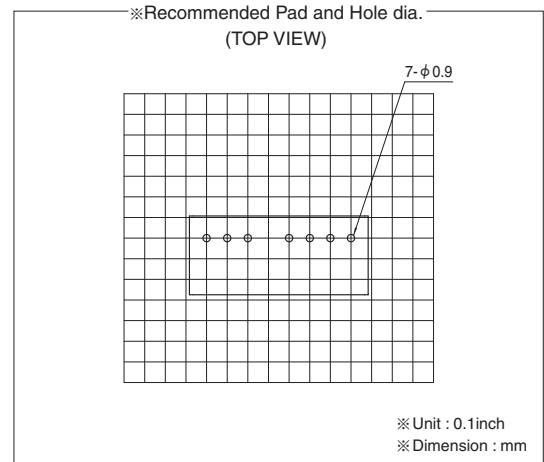
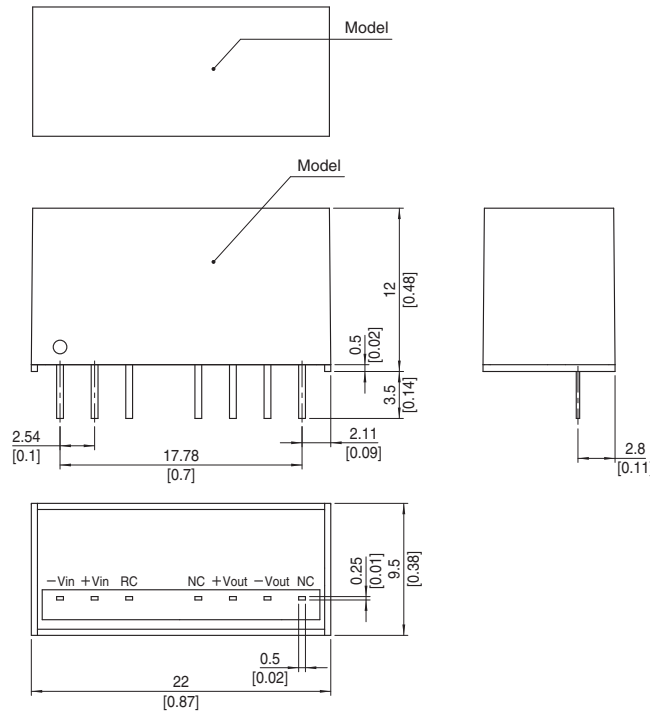

- ※ Tolerance ±0.5 [±0.02]
- ※ Dimensions in mm, []= inches
- ※ Pin terminal material : Copper
- ※ Planting treatment of terminal : Lead free plating
- ※ Case material : PBT
- ※ Weight 7g max

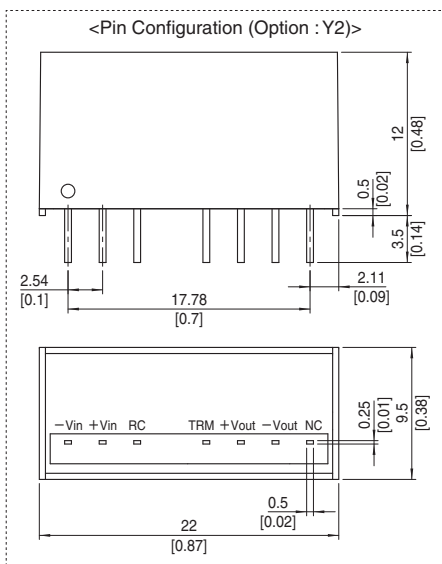

MGW6

MG W 6 24 12 - □

① ② ③ ④ ⑤ ⑥

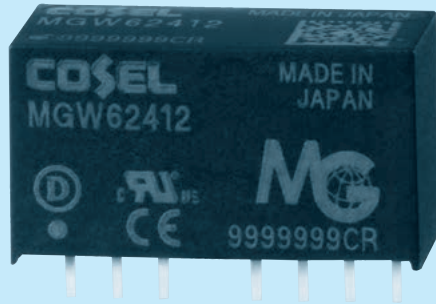

- ① Series name
- ② Dual output
- ③ Output wattage
- ④ Input voltage
- ⑤ Output voltage
- ⑥ Optional
- Y2: Output voltage adjustable (+10%, -5%)

MG

MODEL	MGW60512	MGW60515	MGW61212	MGW61215	MGW62412	MGW62415	MGW64812	MGW64815	
MAX OUTPUT WATTAGE[W]	6.00	6.00	6.00	6.00	6.00	6.00	6.00	6.00	
DC OUTPUT	VOLTAGE[V] *1	±12 or +24	±15 or +30	±12 or +24	±15 or +30	±12 or +24	±15 or +30	±12 or +24	±15 or +30
	CURRENT[A]	0.25	0.2	0.25	0.2	0.25	0.2	0.25	0.2

SPECIFICATIONS

	MODEL	MGW60512	MGW60515	MGW61212	MGW61215	MGW62412	MGW62415	MGW64812	MGW64815	
INPUT	VOLTAGE[V]	DC4.5 - 9 (Surge voltage 12.5V, 100ms max)		DC9 - 18 (Surge voltage 25V, 100ms max)		DC18 - 36 (Surge voltage 50V, 100ms max)		DC36 - 76 (Surge voltage 100V, 100ms max)		
	CURRENT[A] *2	1.38typ	1.38typ	0.57typ	0.57typ	0.29typ	0.29typ	0.15typ	0.15typ	
	EFFICIENCY[%] *2	87typ	87typ	88typ	88typ	88typ	88typ	88typ	88typ	
OUTPUT	VOLTAGE[V]	±12 or +24	±15 or +30	±12 or +24	±15 or +30	±12 or +24	±15 or +30	±12 or +24	±15 or +30	
	CURRENT[A]	0.25	0.2	0.25	0.2	0.25	0.2	0.25	0.2	
	LINE REGULATION[mV]	60max	75max	60max	75max	60max	75max	60max	75max	
	LOAD REGULATION[mV]	*3	480max	600max	480max	600max	480max	600max	480max	600max
		*4	600max	750max	600max	750max	600max	750max	600max	750max
	RIPPLE[mVp-p]	Po=30% to	120max	120max	120max	120max	120max	120max	120max	120max
		*5 Po=0 to 30%	480max	480max	360max	360max	360max	360max	360max	360max
	RIPPLE NOISE[mVp-p]	Po=30% to	200max	200max	200max	200max	200max	200max	200max	200max
		*5 Po=0 to 30%	600max	600max	500max	500max	500max	500max	500max	500max
	TEMPERATURE REGULATION[mV]	-20 to +70°C	180max	220max	180max	220max	180max	220max	180max	220max
	-40 to +70°C	290max	340max	290max	340max	290max	340max	290max	340max	
DRIFT[mV] *6		48max	60max	48max	60max	48max	60max	48max	60max	
START-UP TIME[ms]		30max (Minimum input, Io=100%)								
OUTPUT VOLTAGE SETTING[V]		11.64 - 12.36	14.55 - 15.45	11.64 - 12.36	14.55 - 15.45	11.64 - 12.36	14.55 - 15.45	11.64 - 12.36	14.55 - 15.45	
PROTECTION CIRCUIT AND OTHERS	OVERCURRENT PROTECTION	Works over 105% of rating and recovers automatically								
	REMOTE ON/OFF	Provided (Negative logic L : ON, H : OFF)								
ISOLATION	INPUT-OUTPUT	DC1,500V or AC1,000V 1minute, Cutoff current=10mA, DC500V 1,000MΩ min (20±15°C)								
ENVIRONMENT	OPERATING TEMP., HUMID. AND ALTITUDE	-40 to +85°C, 20 to 95%RH (Non condensing) (Refer to "Derating"), 5,000m (16,400feet) max								
	STORAGE TEMP., HUMID. AND ALTITUDE	-40 to +100°C, 20 to 95%RH (Non condensing), 9,000m (30,000feet) max								
	VIBRATION	10 - 55Hz 98.0m/s ² (10G), 3minute period, 60minutes each along X, Y and Z axis								
	IMPACT	490.3m/s ² (50G) 11ms, once each along X, Y and Z axis								
SAFETY	AGENCY APPROVALS	UL60950-1, C-UL, EN62368-1								
OTHERS	CASE SIZE/WEIGHT	22.0 X 12.0 X 9.5mm [0.87 X 0.48 X 0.38 inches] (W X H X D) / 7g max								
	COOLING METHOD	Convection/Forced air								

*1 Single output +24V, +30V with no use of COM.

*2 Rated input 5V, 12V, 24V or 48V DC Io=100%

*3 Symmetrical loading from 20% to 100%.

*4 Symmetrical loading from 0% to 100%.

*5 Ripple and Ripple Noise is measured by using test board with ceramic capacitor 1μF at 50mm from output pins. (20MHz Oscilloscope). Po:Output wattage.

*6 Drift is the DC output accuracy for eight hours period after a half-hour warm-up at 25°C.

* Parallel operation with other model is not possible.

External view

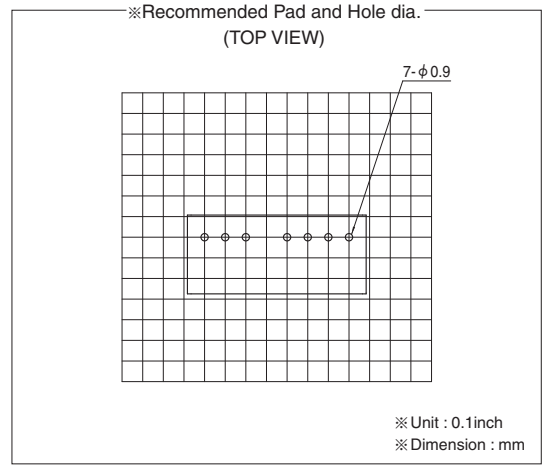
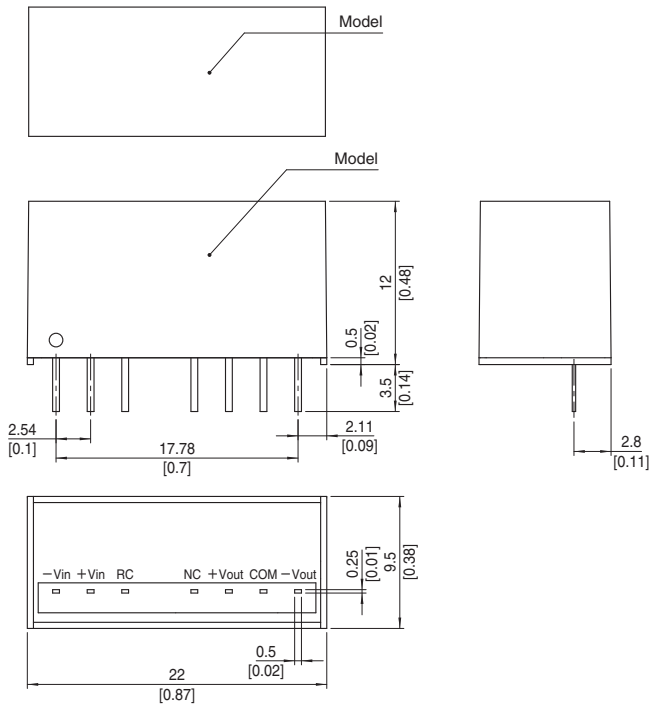

- ※ Tolerance ± 0.5 [± 0.02]
- ※ Dimensions in mm, []= inches
- ※ Pin terminal material : Copper
- ※ Plating treatment of terminal : Lead free plating
- ※ Case material : PBT
- ※ Weight 7g max

MG

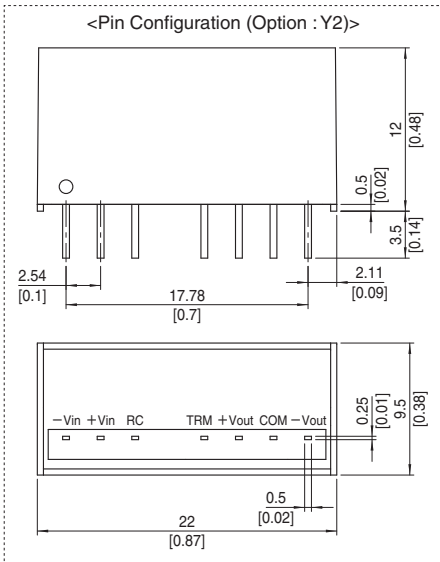

MGS10

MG S 10 24 05 - □

① ② ③ ④ ⑤ ⑥

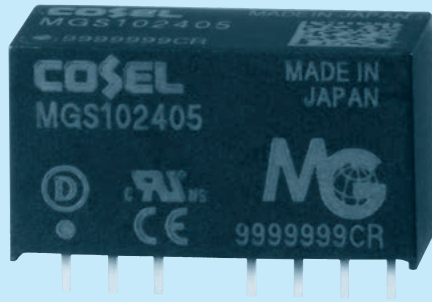

- ① Series name
- ② Single output
- ③ Output wattage
- ④ Input voltage
- ⑤ Output voltage
- ⑥ Optional
- Y2: Output voltage adjustable (+10%, -5%)

MODEL	MGS10053R3	MGS100505	MGS100512	MGS100515	MGS10123R3	MGS101205	MGS101212	MGS101215	
MAX OUTPUT WATTAGE[W]	8.58	10.0	10.8	10.5	8.58	10.0	10.8	10.5	
DC OUTPUT	VOLTAGE[V]	3.3	5	12	15	3.3	5	12	15
	CURRENT[A]	2.6	2.0	0.9	0.7	2.6	2.0	0.9	0.7

SPECIFICATIONS

	MODEL	MGS10053R3	MGS100505	MGS100512	MGS100515	MGS10123R3	MGS101205	MGS101212	MGS101215	
INPUT	VOLTAGE[V]	DC4.5 - 9 (Surge voltage 12.5V, 100ms max)				DC9 - 18 (Surge voltage 25V, 100ms max)				
	CURRENT[A]	*1 2.02typ	2.30typ	2.46typ	2.39typ	0.83typ	0.94typ	1.02typ	0.99typ	
	EFFICIENCY[%]	*1 85typ	87typ	88typ	88typ	87typ	89typ	89typ	89typ	
OUTPUT	VOLTAGE[V]	3.3	5	12	15	3.3	5	12	15	
	CURRENT[A]	2.6	2.0	0.9	0.7	2.6	2.0	0.9	0.7	
	LINE REGULATION[mV]	20max	20max	48max	60max	20max	20max	48max	60max	
	LOAD REGULATION[mV]	20max	20max	48max	60max	20max	20max	48max	60max	
	RIPPLE[mVp-p]	lo=30% -	75max	75max	100max	100max	75max	75max	100max	100max
		lo=0 - 30%	225max	225max	300max	300max	225max	225max	300max	300max
	RIPPLE NOISE[mVp-p]	lo=30% -	120max	120max	150max	150max	120max	120max	150max	150max
		lo=0 - 30%	300max	300max	400max	400max	300max	300max	400max	400max
	TEMPERATURE REGULATION[mV]	-20 to +50°C	50max	50max	150max	180max	50max	50max	150max	180max
		-40 to +50°C	80max	80max	240max	290max	80max	80max	240max	290max
DRIFT[mV]	*3 20max	20max	48max	60max	20max	20max	48max	60max		
START-UP TIME[ms]	30max (Minimum input, lo=100%)									
OUTPUT VOLTAGE SETTING[V]	3.21 - 3.42	4.90 - 5.21	11.64 - 12.36	14.55 - 15.45	3.21 - 3.42	4.90 - 5.21	11.64 - 12.36	14.55 - 15.45		
PROTECTION CIRCUIT AND OTHERS	OVERCURRENT PROTECTION	Works over 105% of rating and recovers automatically								
	REMOTE ON/OFF	Provided (Negative logic L : ON, H : OFF)								

MODEL	MGS10243R3	MGS102405	MGS102412	MGS102415	MGS10483R3	MGS104805	MGS104812	MGS104815	
MAX OUTPUT WATTAGE[W]	8.58	10.0	10.8	10.5	8.58	10.0	10.8	10.5	
DC OUTPUT	VOLTAGE[V]	*1 3.3	5	12	15	3.3	5	12	15
	CURRENT[A]	2.6	2.0	0.9	0.7	2.6	2.0	0.9	0.7

SPECIFICATIONS

	MODEL	MGS10243R3	MGS102405	MGS102412	MGS102415	MGS10483R3	MGS104805	MGS104812	MGS104815	
INPUT	VOLTAGE[V]	DC18 - 36 (Surge voltage 50V, 100ms max)				DC36 - 76 (Surge voltage 100V, 100ms max)				
	CURRENT[A]	*1 0.42typ	0.47typ	0.50typ	0.49typ	0.21typ	0.24typ	0.25typ	0.25typ	
	EFFICIENCY[%]	*1 87typ	89typ	90typ	90typ	87typ	89typ	90typ	90typ	
OUTPUT	VOLTAGE[V]	3.3	5	12	15	3.3	5	12	15	
	CURRENT[A]	2.6	2.0	0.9	0.7	2.6	2.0	0.9	0.7	
	LINE REGULATION[mV]	20max	20max	48max	60max	20max	20max	48max	60max	
	LOAD REGULATION[mV]	20max	20max	48max	60max	20max	20max	48max	60max	
	RIPPLE[mVp-p]	lo=30% -	75max	75max	100max	100max	75max	75max	100max	100max
		lo=0 - 30%	225max	225max	300max	300max	225max	225max	300max	300max
	RIPPLE NOISE[mVp-p]	lo=30% -	120max	120max	150max	150max	120max	120max	150max	150max
		lo=0 - 30%	300max	300max	400max	400max	300max	300max	400max	400max
	TEMPERATURE REGULATION[mV]	-20 to +50°C	50max	50max	150max	180max	50max	50max	150max	180max
		-40 to +50°C	80max	80max	240max	290max	80max	80max	240max	290max
DRIFT[mV]	*3 20max	20max	48max	60max	20max	20max	48max	60max		
START-UP TIME[ms]	30max (Minimum input, lo=100%)									
OUTPUT VOLTAGE SETTING[V]	3.21 - 3.42	4.90 - 5.21	11.64 - 12.36	14.55 - 15.45	3.21 - 3.42	4.90 - 5.21	11.64 - 12.36	14.55 - 15.45		
PROTECTION CIRCUIT AND OTHERS	OVERCURRENT PROTECTION	Works over 105% of rating and recovers automatically								
	REMOTE ON/OFF	Provided (Negative logic L : ON, H : OFF)								

GENERAL SPECIFICATIONS

ISOLATION	INPUT-OUTPUT	DC1,500V or AC1,000V 1minute, Cutoff current=10mA, DC500V 1,000MΩ min (20±15°C)
ENVIRONMENT	OPERATING TEMP., HUMID. AND ALTITUDE	-40 to +85°C, 20 to 95%RH (Non condensing) (Refer to "Derating"), 5,000m (16,400feet) max
	STORAGE TEMP., HUMID. AND ALTITUDE	-40 to +100°C, 20 to 95%RH (Non condensing), 9,000m (30,000feet) max
	VIBRATION	10 - 55Hz 98.0m/s ² (10G), 3minute period, 60minutes each along X, Y and Z axis
	IMPACT	490.3m/s ² (50G) 11ms, once each along X, Y and Z axis
SAFETY	AGENCY APPROVALS	UL60950-1, C-UL, EN62368-1
OTHERS	CASE SIZE/WEIGHT	22.0×12.0×9.5mm [0.87×0.48×0.38 inches] (W×H×D) / 7g max
	COOLING METHOD	Convection/Forced air

- *1 Rated input 5V, 12V, 24V or 48V DC I_o=100%
- *2 Ripple and ripple noise is measured by using test board with ceramic capacitor 1μF at 50mm from output pins.
- *3 Drift is the DC output accuracy for eight hours period after a half-hour warm-up at 25°C.
- * Parallel operation with other model is not possible.
- * MGW10xx12/MGW10xx15 is available as single output, +24V/+30V

External view

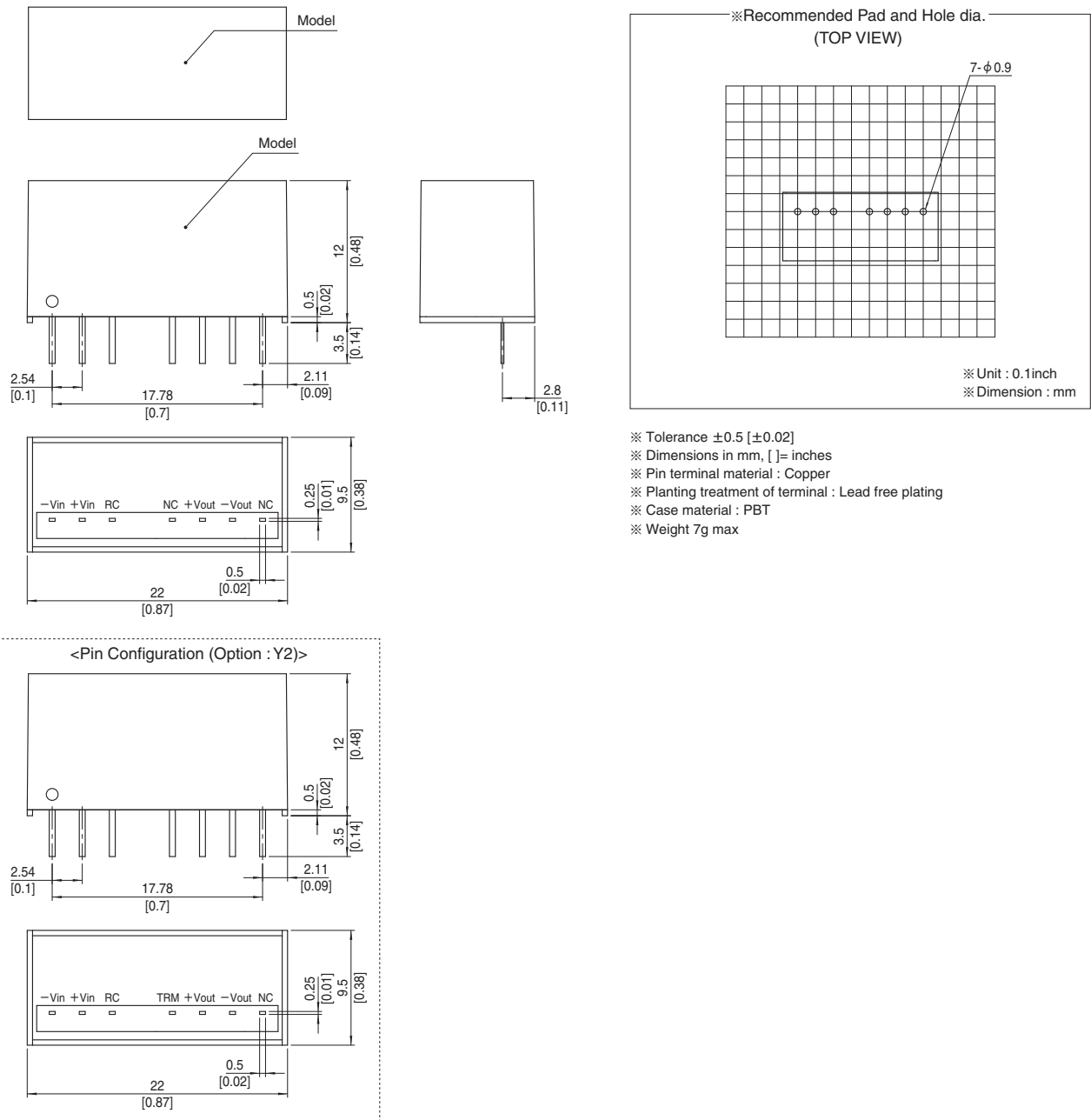

MG

MGW10

MG W 10 24 12 - □

① ② ③ ④ ⑤ ⑥

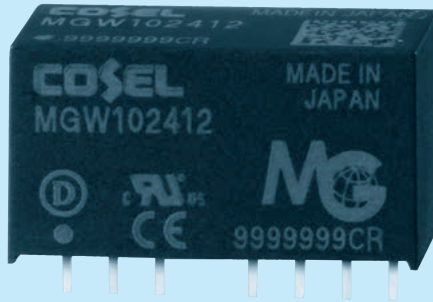

- ① Series name
- ② Dual output
- ③ Output wattage
- ④ Input voltage
- ⑤ Output voltage
- ⑥ Optional
- Y2: Output voltage adjustable (+10%, -5%)

MG

MODEL	MGW100512	MGW100515	MGW101212	MGW101215	MGW102412	MGW102415	MGW104812	MGW104815	
MAX OUTPUT WATTAGE[W]	10.08	10.20	10.08	10.20	10.08	10.20	10.08	10.20	
DC OUTPUT	VOLTAGE[V] *1	±12 or +24	±15 or +30	±12 or +24	±15 or +30	±12 or +24	±15 or +30	±12 or +24	±15 or +30
	CURRENT[A]	0.42	0.34	0.42	0.34	0.42	0.34	0.42	0.34

SPECIFICATIONS

	MODEL	MGW100512	MGW100515	MGW101212	MGW101215	MGW102412	MGW102415	MGW104812	MGW104815	
INPUT	VOLTAGE[V]	DC4.5 - 9 (Surge voltage 12.5V, 100ms max)		DC9 - 18 (Surge voltage 25V, 100ms max)		DC18 - 36 (Surge voltage 50V, 100ms max)		DC36 - 76 (Surge voltage 100V, 100ms max)		
	CURRENT[A] *2	2.38typ	2.40typ	0.97typ	0.97typ	0.49typ	0.49typ	0.24typ	0.25typ	
	EFFICIENCY[%] *2	85typ	85typ	87typ	88typ	87typ	88typ	88typ	88typ	
OUTPUT	VOLTAGE[V]	±12 or +24	±15 or +30	±12 or +24	±15 or +30	±12 or +24	±15 or +30	±12 or +24	±15 or +30	
	CURRENT[A]	0.42	0.34	0.42	0.34	0.42	0.34	0.42	0.34	
	LINE REGULATION[mV]	60max	75max	60max	75max	60max	75max	60max	75max	
	LOAD REGULATION[mV]	*3	480max	600max	480max	600max	480max	600max	480max	600max
		*4	600max	750max	600max	750max	600max	750max	600max	750max
	RIPPLE[mVp-p]	Po=30% to	120max	120max	120max	120max	120max	120max	120max	120max
		*5 Po=0 to 30%	480max	480max	360max	360max	360max	360max	360max	360max
	RIPPLE NOISE[mVp-p]	Po=30% to	200max	200max	200max	200max	200max	200max	200max	200max
		*5 Po=0 to 30%	600max	600max	500max	500max	500max	500max	500max	500max
	TEMPERATURE REGULATION[mV]	-20 to +50°C	150max	180max	150max	180max	150max	180max	150max	180max
	-40 to +50°C	240max	290max	240max	290max	240max	290max	240max	290max	
DRIFT[mV] *6		48max	60max	48max	60max	48max	60max	48max	60max	
START-UP TIME[ms]		30max (Minimum input, Io=100%)								
OUTPUT VOLTAGE SETTING[V]		11.64 - 12.36	14.55 - 15.45	11.64 - 12.36	14.55 - 15.45	11.64 - 12.36	14.55 - 15.45	11.64 - 12.36	14.55 - 15.45	
PROTECTION CIRCUIT AND OTHERS	OVERCURRENT PROTECTION	Works over 105% of rating and recovers automatically								
	REMOTE ON/OFF	Provided (Negative logic L : ON, H : OFF)								
ISOLATION	INPUT-OUTPUT	DC1,500V or AC1,000V 1minute, Cutoff current=10mA, DC500V 1,000MΩ min (20±15°C)								
ENVIRONMENT	OPERATING TEMP., HUMID. AND ALTITUDE	-40 to +85°C, 20 to 95%RH (Non condensing) (Refer to "Derating"), 5,000m (16,400feet) max								
	STORAGE TEMP., HUMID. AND ALTITUDE	-40 to +100°C, 20 to 95%RH (Non condensing), 9,000m (30,000feet) max								
	VIBRATION	10 - 55Hz 98.0m/s ² (10G), 3minute period, 60minutes each along X, Y and Z axis								
	IMPACT	490.3m/s ² (50G) 11ms, once each along X, Y and Z axis								
SAFETY	AGENCY APPROVALS	UL60950-1, C-UL, EN62368-1								
OTHERS	CASE SIZE/WEIGHT	22.0 X 12.0 X 9.5mm [0.87 X 0.48 X 0.38 inches] (W X H X D) / 7g max								
	COOLING METHOD	Convection/Forced air								

*1 Single output +24V, +30V with no use of COM.

*2 Rated input 5V, 12V, 24V or 48V DC Io=100%

*3 Symmetrical loading from 20% to 100%.

*4 Symmetrical loading from 0% to 100%.

*5 Ripple and Ripple Noise is measured by using test board with ceramic capacitor 1μF at 50mm from output pins. (20MHz Oscilloscope). Po:Output wattage.

*6 Drift is the DC output accuracy for eight hours period after a half-hour warm-up at 25°C.

* Parallel operation with other model is not possible.

External view

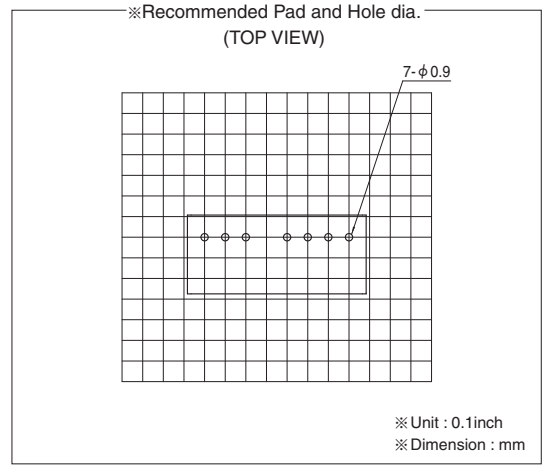
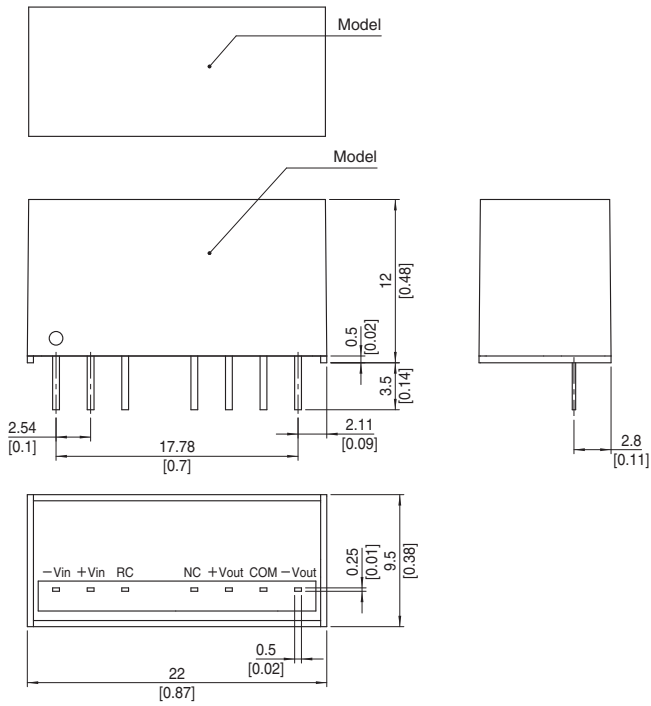

- ※ Tolerance ± 0.5 [± 0.02]
- ※ Dimensions in mm, []= inches
- ※ Pin terminal material : Copper
- ※ Plating treatment of terminal : Lead free plating
- ※ Case material : PBT
- ※ Weight 7g max

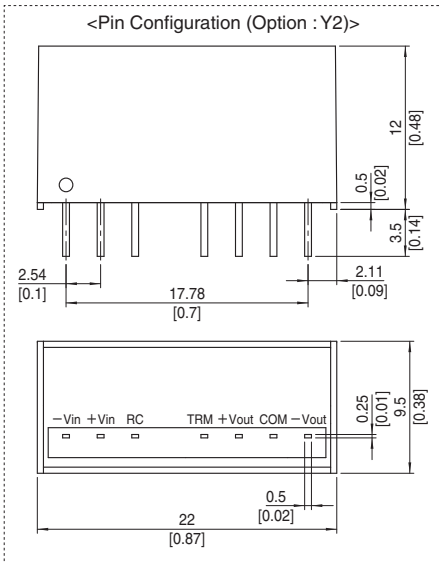

MGFS1R5

MGF S 1R5 24 05 -□

① ② ③ ④ ⑤ ⑥

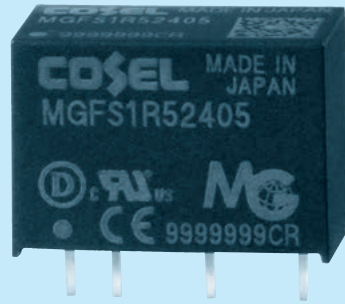

- ① Series name
- ② Single output
- ③ Output wattage
- ④ Input voltage
- ⑤ Output voltage
- ⑥ Optional
- Y2: Output voltage adjustable (+10%, -5%)

MODEL	MGFS1R5243R3	MGFS1R52405	MGFS1R52412	MGFS1R52415
MAX OUTPUT WATTAGE[W]	1.32	1.50	1.56	1.50
DC OUTPUT	VOLTAGE[V]	3.3	5	12
	CURRENT[A]	0.4	0.3	0.13

SPECIFICATIONS

	MODEL	MGFS1R5243R3	MGFS1R52405	MGFS1R52412	MGFS1R52415	
INPUT	VOLTAGE[V]	DC9 - 36(Surge voltage 50V,100ms max)				
	CURRENT[A]	*1 0.072typ	0.079typ	0.079typ	0.077typ	
	EFFICIENCY[%]	*1 77typ	80typ	83typ	82typ	
OUTPUT	VOLTAGE[V]	3.3	5	12	15	
	CURRENT[A]	0.4	0.3	0.13	0.1	
	LINE REGULATION[mV]	20max	20max	48max	60max	
	LOAD REGULATION[mV]	20max	20max	48max	60max	
	RIPPLE[mVp-p]	*2 120max	120max	150max	150max	
	RIPPLE NOISE[mVp-p]	*2 200max	200max	200max	200max	
	TEMPERATURE REGULATION[mV]	-20 to +85°C	50max	50max	150max	180max
		-40 to +85°C	80max	80max	240max	290max
	DRIFT[mV]	*3 20max	20max	48max	60max	
	START-UP TIME[ms]	30max (Minimum input, I _o =100%)				
PROTECTION CIRCUIT	OUTPUT VOLTAGE SETTING[V]	3.21 - 3.42	4.90 - 5.21	11.64 - 12.36	14.55 - 15.45	
	OVERCURRENT PROTECTION	Works over 105% of rating and recovers automatically				

MODEL	MGFS1R5483R3	MGFS1R54805	MGFS1R54812	MGFS1R54815
MAX OUTPUT WATTAGE[W]	1.32	1.50	1.56	1.50
DC OUTPUT	VOLTAGE[V]	3.3	5	12
	CURRENT[A]	0.4	0.3	0.13

SPECIFICATIONS

	MODEL	MGFS1R5483R3	MGFS1R54805	MGFS1R54812	MGFS1R54815	
INPUT	VOLTAGE[V]	DC18 - 76(Surge voltage 100V,100ms max)				
	CURRENT[A]	*1 0.037typ	0.040typ	0.040typ	0.039typ	
	EFFICIENCY[%]	*1 76typ	79typ	82typ	81typ	
OUTPUT	VOLTAGE[V]	3.3	5	12	15	
	CURRENT[A]	0.4	0.3	0.13	0.1	
	LINE REGULATION[mV]	20max	20max	48max	60max	
	LOAD REGULATION[mV]	20max	20max	48max	60max	
	RIPPLE[mVp-p]	*2 120max	120max	150max	150max	
	RIPPLE NOISE[mVp-p]	*2 200max	200max	200max	200max	
	TEMPERATURE REGULATION[mV]	-20 to +85°C	50max	50max	150max	180max
		-40 to +85°C	80max	80max	240max	290max
	DRIFT[mV]	*3 20max	20max	48max	60max	
	START-UP TIME[ms]	30max (Minimum input, I _o =100%)				
PROTECTION CIRCUIT	OUTPUT VOLTAGE SETTING[V]	3.21 - 3.42	4.90 - 5.21	11.64 - 12.36	14.55 - 15.45	
	OVERCURRENT PROTECTION	Works over 105% of rating and recovers automatically				

GENERAL SPECIFICATIONS

ISOLATION	INPUT-OUTPUT	DC1,500V or AC1,000V 1minute, Cutoff current=10mA, DC500V 1,000MΩ min (20±15°C)
ENVIRONMENT	OPERATING TEMP., HUMID. AND ALTITUDE	-40 to +85°C, 20 to 95%RH (Non condensing) (Refer to "Derating"), 5,000m (16,400feet) max
	STORAGE TEMP., HUMID. AND ALTITUDE	-40 to +100°C, 20 to 95%RH (Non condensing), 9,000m (30,000feet) max
	VIBRATION	10 - 55Hz 98.0m/s ² (10G), 3minute period, 60minutes each along X, Y and Z axis
	IMPACT	490.3m/s ² (50G) 11ms, once each along X, Y and Z axis
SAFETY	AGENCY APPROVALS	UL60950-1, C-UL, EN62368-1
OTHERS	CASE SIZE/WEIGHT	17.0×12.0×8.5mm [0.67×0.48×0.34 inches] (W×H×D) / 4g max
	COOLING METHOD	Convection/Forced air

- *1 Rated input 24V or 48V DC I_o=100%
- *2 Ripple and ripple noise is measured by using test board with ceramic capacitor 1μF at 50mm from output pins.
- *3 Drift is the DC output accuracy for eight hours period after a half-hour warm-up at 25°C.
- * Parallel operation with other model is not possible.
- * MGFW1R5xx12/MGFW1R5xx15 is available as single output, +24V/+30V

External view

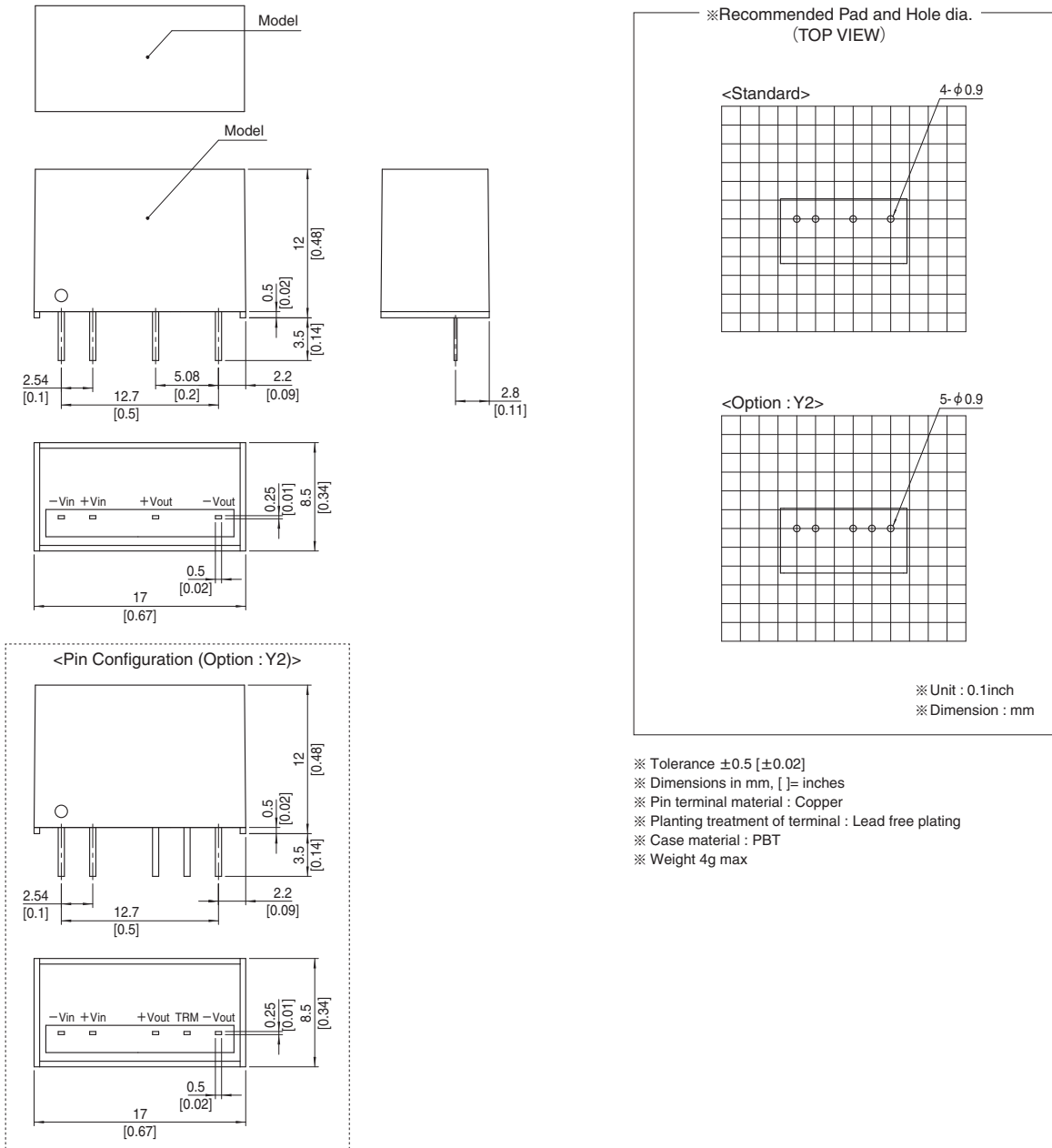

MG

MGFW1R5

MGF W 1R5 24 12 -□

① ② ③ ④ ⑤ ⑥

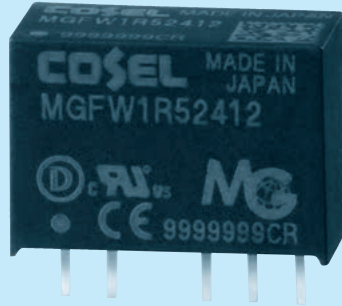

- ① Series name
- ② Dual output
- ③ Output wattage
- ④ Input voltage
- ⑤ Output voltage
- ⑥ Optional

MG

MODEL	MGFW1R52412	MGFW1R52415	MGFW1R54812	MGFW1R54815
MAX OUTPUT WATTAGE[W]	1.56	1.50	1.56	1.50
DC OUTPUT	VOLTAGE[V] *1	±12 or +24	±12 or +24	±15 or +30
	CURRENT[A]	0.065	0.05	0.065

SPECIFICATIONS

	MODEL	MGFW1R52412	MGFW1R52415	MGFW1R54812	MGFW1R54815	
INPUT	VOLTAGE[V]	DC9 - 36 (Surge voltage 50V, 100ms max)		DC18 - 76 (Surge voltage 100V, 100ms max)		
	CURRENT[A] *2	0.081typ	0.079typ	0.041typ	0.040typ	
	EFFICIENCY[%] *2	81typ	80typ	81typ	79typ	
OUTPUT	VOLTAGE[V]	±12 (+24)	±15 (+30)	±12 (+24)	±15 (+30)	
	CURRENT[A]	0.065	0.05	0.065	0.05	
	LINE REGULATION[mV]	60max	75max	60max	75max	
	LOAD REGULATION[mV]	*3	480max	600max	480max	600max
		*4	600max	750max	600max	750max
	RIPPLE[mVp-p] *5	150max	150max	150max	150max	
	RIPPLE NOISE[mVp-p] *5	200max	200max	200max	200max	
	TEMPERATURE REGULATION[mV]	-20 to +85°C	210max	260max	150max	180max
		-40 to +85°C	320max	390max	240max	290max
	DRIFT[mV] *6	48max	60max	48max	60max	
START-UP TIME[ms]	30max (Minimum input, I _o =100%)					
OUTPUT VOLTAGE SETTING[V]	11.64 - 12.36	14.55 - 15.45	11.64 - 12.36	14.55 - 15.45		
PROTECTION CIRCUIT	OVERCURRENT PROTECTION	Works over 105% of rating and recovers automatically				
ISOLATION	INPUT-OUTPUT	DC1,500V or AC1,000V 1minute, Cutoff current=10mA, DC500V 1,000MΩ min (20±15°C)				
ENVIRONMENT	OPERATING TEMP., HUMID. AND ALTITUDE	-40 to +85°C, 20 to 95%RH (Non condensing) (Refer to "Derating"), 5,000m (16,400feet) max				
	STORAGE TEMP., HUMID. AND ALTITUDE	-40 to +100°C, 20 to 95%RH (Non condensing), 9,000m (30,000feet) max				
	VIBRATION	10 - 55Hz 98.0m/s ² (10G), 3minute period, 60minutes each along X, Y and Z axis				
	IMPACT	490.3m/s ² (50G) 11ms, once each along X, Y and Z axis				
SAFETY	AGENCY APPROVALS	UL60950-1, C-UL, EN62368-1				
OTHERS	CASE SIZE/WEIGHT	17.0 X 12.0 X 8.5mm [0.67 X 0.48 X 0.34 inches] (W X H X D) / 4g max				
	COOLING METHOD	Convection/Forced air				

- *1 Single output +24V, +30V with no use of COM.
- *2 Rated input 24V or 48V DC I_o=100%
- *3 Symmetrical loading from 20% to 100%.
- *4 Symmetrical loading from 0% to 100%.
- *5 Ripple and Ripple Noise is measured by using test board with ceramic capacitor 1μF at 50mm from output pins.
- *6 Drift is the DC output accuracy for eight hours period after a half-hour warm-up at 25°C.
- * Parallel operation with other model is not possible.

External view

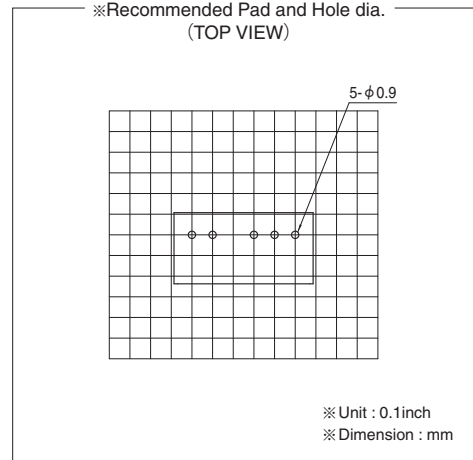
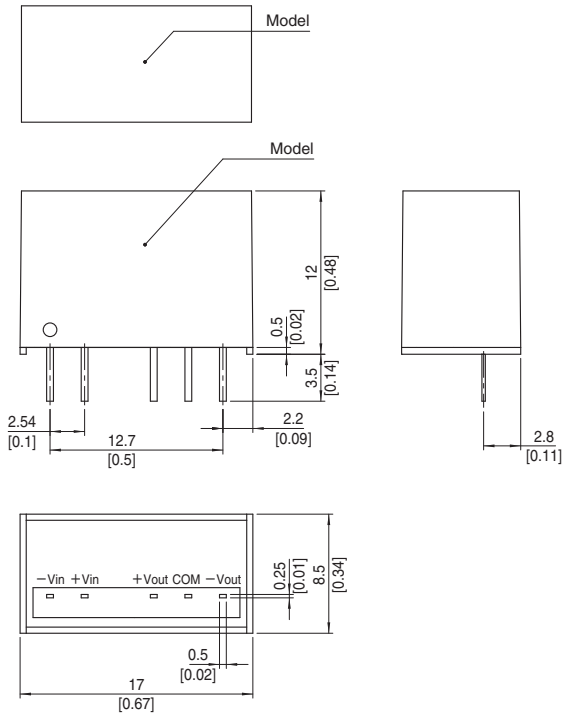

- ※ Tolerance ± 0.5 [± 0.02]
- ※ Dimensions in mm, []= inches
- ※ Pin terminal material : Copper
- ※ Plating treatment of terminal : Lead free plating
- ※ Case material : PBT
- ※ Weight 4g max

MG

MGFS3

MGF S 3 24 05 -□

① ② ③ ④ ⑤ ⑥

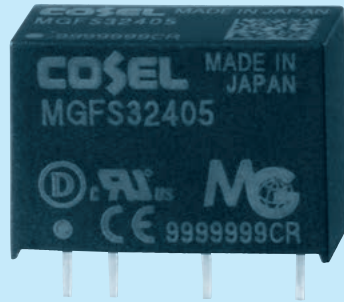

- ① Series name
- ② Single output
- ③ Output wattage
- ④ Input voltage
- ⑤ Output voltage
- ⑥ Optional
- Y2: Output voltage adjustable (+10%, -5%)

MODEL	MGFS3243R3	MGFS32405	MGFS32412	MGFS32415
MAX OUTPUT WATTAGE[W]	2.64	3.00	3.00	3.00
DC OUTPUT	VOLTAGE[V]	3.3	5	12
	CURRENT[A]	0.8	0.6	0.25

SPECIFICATIONS

	MODEL	MGFS3243R3	MGFS32405	MGFS32412	MGFS32415
INPUT	VOLTAGE[V]	DC9 - 36 (Surge voltage 50V,100ms max) (Refer to "Derating" for input voltage derating.)			
	CURRENT[A]	*1 0.15typ	0.16typ	0.15typ	0.15typ
	EFFICIENCY[%]	*1 78typ	81typ	85typ	84typ
OUTPUT	VOLTAGE[V]	3.3	5	12	15
	CURRENT[A]	0.8	0.6	0.25	0.2
	LINE REGULATION[mV]	20max	20max	48max	60max
	LOAD REGULATION[mV]	20max	20max	48max	60max
	RIPPLE[mVp-p]	*2 120max	120max	150max	150max
	RIPPLE NOISE[mVp-p]	*2 200max	200max	200max	200max
	TEMPERATURE REGULATION[mV]	-20 to +75°C 50max	50max	150max	180max
		-40 to +75°C 80max	80max	240max	290max
	DRIFT[mV]	*3 20max	20max	48max	60max
	START-UP TIME[ms]	30max (Minimum input, I _o =100%)			
PROTECTION CIRCUIT	OUTPUT VOLTAGE SETTING[V]	3.21 - 3.42	4.90 - 5.21	11.64 - 12.36	14.55 - 15.45
	OVERCURRENT PROTECTION	Works over 105% of rating and recovers automatically			

MODEL	MGFS3483R3	MGFS34805	MGFS34812	MGFS34815
MAX OUTPUT WATTAGE[W]	2.64	3.00	3.00	3.00
DC OUTPUT	VOLTAGE[V]	3.3	5	12
	CURRENT[A]	0.8	0.6	0.25

SPECIFICATIONS

	MODEL	MGFS3483R3	MGFS34805	MGFS34812	MGFS34815
INPUT	VOLTAGE[V]	DC18 - 76 (Surge voltage 100V,100ms max) (Refer to "Derating" for input voltage derating.)			
	CURRENT[A]	*1 0.072typ	0.079typ	0.076typ	0.076typ
	EFFICIENCY[%]	*1 77typ	80typ	83typ	83typ
OUTPUT	VOLTAGE[V]	3.3	5	12	15
	CURRENT[A]	0.8	0.6	0.25	0.2
	LINE REGULATION[mV]	20max	20max	48max	60max
	LOAD REGULATION[mV]	20max	20max	48max	60max
	RIPPLE[mVp-p]	*2 120max	120max	150max	150max
	RIPPLE NOISE[mVp-p]	*2 200max	200max	200max	200max
	TEMPERATURE REGULATION[mV]	-20 to +75°C 50max	50max	150max	180max
		-40 to +75°C 80max	80max	240max	290max
	DRIFT[mV]	*3 20max	20max	48max	60max
	START-UP TIME[ms]	30max (Minimum input, I _o =100%)			
PROTECTION CIRCUIT	OUTPUT VOLTAGE SETTING[V]	3.21 - 3.42	4.90 - 5.21	11.64 - 12.36	14.55 - 15.45
	OVERCURRENT PROTECTION	Works over 105% of rating and recovers automatically			

GENERAL SPECIFICATIONS

ISOLATION	INPUT-OUTPUT	DC1,500V or AC1,000V 1minute, Cutoff current=10mA, DC500V 1,000MΩ min (20±15°C)
ENVIRONMENT	OPERATING TEMP.,HUMID.AND ALTITUDE	-40 to +85°C, 20 to 95%RH (Non condensing) (Refer to "Derating"), 5,000m (16,400feet) max
	STORAGE TEMP.,HUMID.AND ALTITUDE	-40 to +100°C, 20 to 95%RH (Non condensing), 9,000m (30,000feet) max
	VIBRATION	10 - 55Hz 98.0m/s ² (10G), 3minute period, 60minutes each along X, Y and Z axis
	IMPACT	490.3m/s ² (50G) 11ms, once each along X, Y and Z axis
SAFETY	AGENCY APPROVALS	UL60950-1, C-UL, EN62368-1
OTHERS	CASE SIZE/WEIGHT	17.0×12.0×8.5mm [0.67×0.48×0.34 inches] (W×H×D) / 4g max
	COOLING METHOD	Convection/Forced air

- *1 Rated input 24V or 48V DC Io=100%
- *2 Ripple and ripple noise is measured by using test board with ceramic capacitor 1μF at 50mm from output pins.
- *3 Drift is the DC output accuracy for eight hours period after a half-hour warm-up at 25°C.
- * Parallel operation with other model is not possible.
- * MGFW3xx12/MGFW3xx15 is available as single output, +24V/+30V

External view

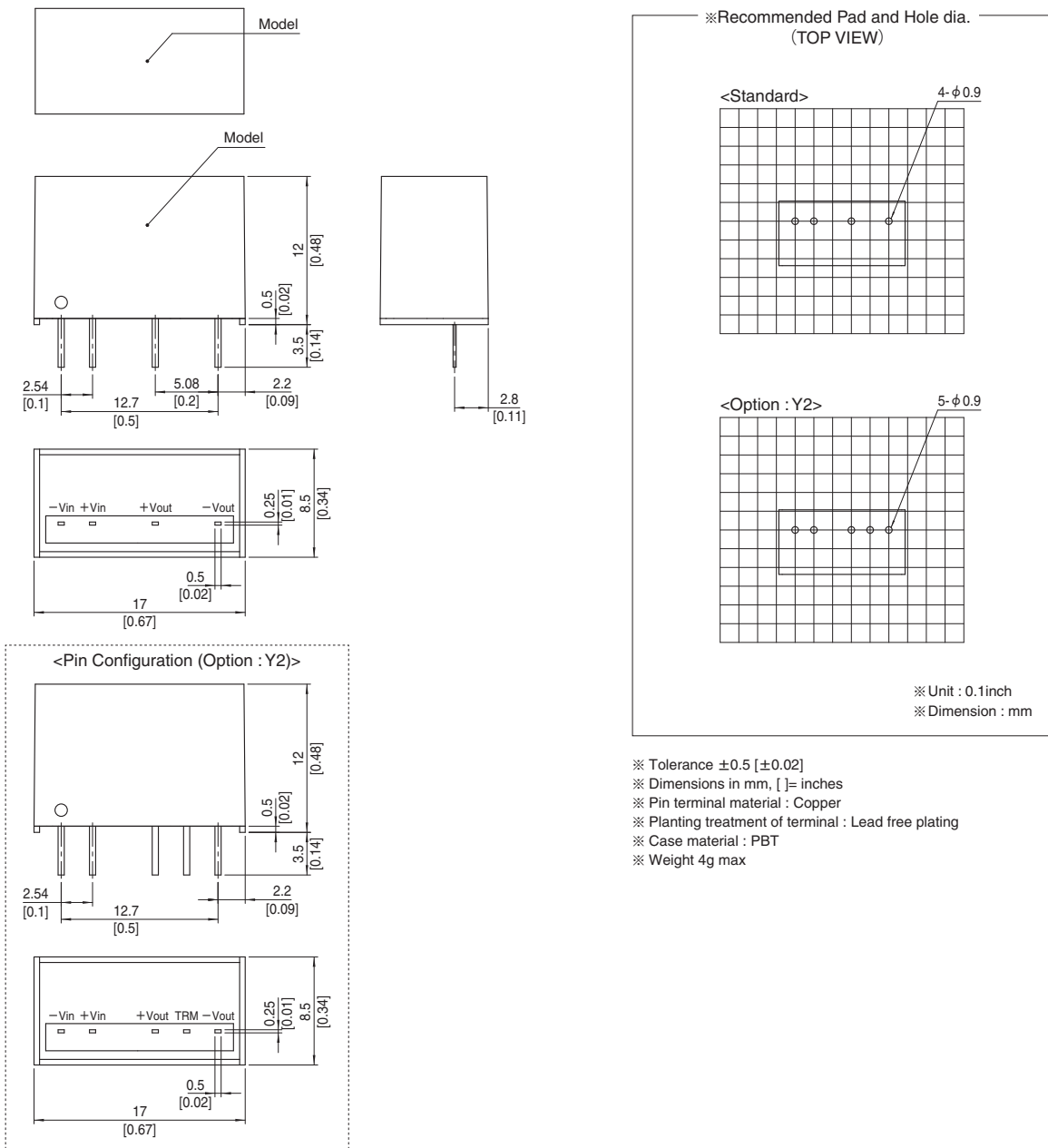

MG

MGFW3

MGF W 3 24 12 - □

① ② ③ ④ ⑤ ⑥

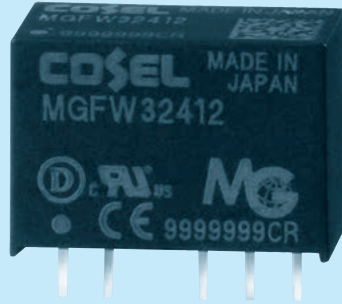

- ① Series name
- ② Dual output
- ③ Output wattage
- ④ Input voltage
- ⑤ Output voltage
- ⑥ Optional

MODEL	MGFW32412	MGFW32415	MGFW34812	MGFW34815
MAX OUTPUT WATTAGE[W]	3.12	3.00	3.12	3.00
DC OUTPUT	VOLTAGE[V] *1	±12 or +24	±12 or +24	±15 or +30
	CURRENT[A]	0.13	0.1	0.13

SPECIFICATIONS

	MODEL	MGFW32412	MGFW32415	MGFW34812	MGFW34815	
INPUT	VOLTAGE[V]	DC9 - 36 (Surge voltage 50V,100ms max) (Refer to "Derating" for input voltage derating.)		DC18 - 76 (Surge voltage 100V,100ms max) (Refer to "Derating" for input voltage derating.)		
	CURRENT[A] *2	0.16typ	0.16typ	0.081typ	0.078typ	
	EFFICIENCY[%] *2	82typ	82typ	81typ	81typ	
OUTPUT	VOLTAGE[V]	±12 (+24)	±15 (+30)	±12 (+24)	±15 (+30)	
	CURRENT[A]	0.13	0.1	0.13	0.1	
	LINE REGULATION[mV]	60max	75max	60max	75max	
	LOAD REGULATION[mV]	*3	480max	600max	480max	600max
		*4	600max	750max	600max	750max
	RIPPLE[mVp-p] *5	150max	150max	150max	150max	
	RIPPLE NOISE[mVp-p] *5	200max	200max	200max	200max	
	TEMPERATURE REGULATION[mV]	-20 to +70°C	180max	220max	180max	220max
		-40 to +70°C	290max	340max	290max	340max
	DRIFT[mV] *6	48max	60max	48max	60max	
START-UP TIME[ms]	30max (Minimum input, I _o =100%)					
OUTPUT VOLTAGE SETTING[V]	11.64 - 12.36	14.55 - 15.45	11.64 - 12.36	14.55 - 15.45		
PROTECTION CIRCUIT	OVERCURRENT PROTECTION	Works over 105% of rating and recovers automatically				
ISOLATION	INPUT-OUTPUT	DC1,500V or AC1,000V 1minute, Cutoff current=10mA, DC500V 1,000MΩ min (20±15°C)				
ENVIRONMENT	OPERATING TEMP., HUMID. AND ALTITUDE	-40 to +85°C, 20 to 95%RH (Non condensing) (Refer to "Derating"), 5,000m (16,400feet) max				
	STORAGE TEMP., HUMID. AND ALTITUDE	-40 to +100°C, 20 to 95%RH (Non condensing), 9,000m (30,000feet) max				
	VIBRATION	10 - 55Hz 98.0m/s ² (10G), 3minute period, 60minutes each along X, Y and Z axis				
	IMPACT	490.3m/s ² (50G) 11ms, once each along X, Y and Z axis				
SAFETY	AGENCY APPROVALS	UL60950-1, C-UL, EN62368-1				
OTHERS	CASE SIZE/WEIGHT	17.0 × 12.0 × 8.5mm [0.67 × 0.48 × 0.34 inches] (W × H × D) / 4g max				
	COOLING METHOD	Convection/Forced air				

- *1 Single output +24V, +30V with no use of COM.
- *2 Rated input 24V or 48V DC I_o=100%
- *3 Symmetrical loading from 20% to 100%.
- *4 Symmetrical loading from 0% to 100%.
- *5 Ripple and Ripple Noise is measured by using test board with ceramic capacitor 1μF at 50mm from output pins.
- *6 Drift is the DC output accuracy for eight hours period after a half-hour warm-up at 25°C.
- * Parallel operation with other model is not possible.

External view

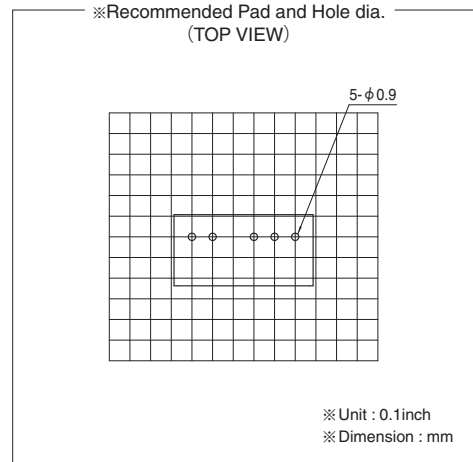
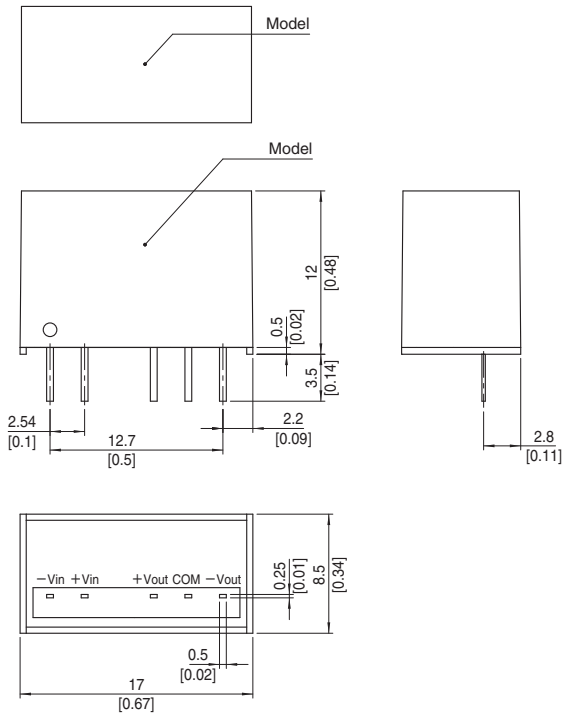

- ※ Tolerance ± 0.5 [± 0.02]
- ※ Dimensions in mm, []= inches
- ※ Pin terminal material : Copper
- ※ Plating treatment of terminal : Lead free plating
- ※ Case material : PBT
- ※ Weight 4g max

MG

MGFS6

MGF S 6 24 05 -□

① ② ③ ④ ⑤ ⑥

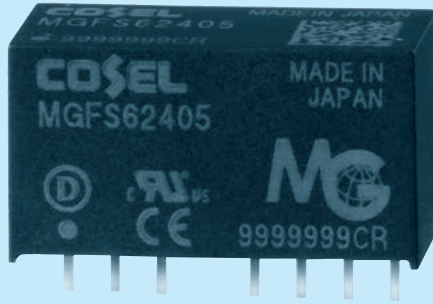

- ① Series name
- ② Single output
- ③ Output wattage
- ④ Input voltage
- ⑤ Output voltage
- ⑥ Optional
- Y2: Output voltage adjustable (+10%, -5%)

MODEL	MGFS6243R3	MGFS62405	MGFS62412	MGFS62415
MAX OUTPUT WATTAGE[W]	5.28	6.0	6.0	6.0
DC OUTPUT	VOLTAGE[V]	3.3	5	12
	CURRENT[A]	1.6	1.2	0.5

SPECIFICATIONS

	MODEL	MGFS6243R3	MGFS62405	MGFS62412	MGFS62415	
INPUT	VOLTAGE[V]	DC9 - 36 (Surge voltage 50V,100ms max)				
	CURRENT[A]	*1 0.28typ	0.30typ	0.29typ	0.29typ	
	EFFICIENCY[%]	*1 80typ	84typ	88typ	88typ	
OUTPUT	VOLTAGE[V]	3.3	5	12	15	
	CURRENT[A]	1.6	1.2	0.5	0.4	
	LINE REGULATION[mV]	20max	20max	48max	60max	
	LOAD REGULATION[mV]	20max	20max	48max	60max	
	RIPPLE[mVp-p]	Io=30% -	75max	75max	100max	100max
		Io=0 - 30%	*2 225max	225max	300max	300max
	RIPPLE NOISE[mVp-p]	Io=30% -	120max	120max	150max	150max
		Io=0 - 30%	*2 300max	300max	400max	400max
	TEMPERATURE REGULATION[mV]	-20 to +65°C	50max	50max	150max	180max
		-40 to +65°C	80max	80max	240max	290max
	DRIFT[mV]	*3 20max	20max	48max	60max	
START-UP TIME[ms]	30max (Minimum input, Io=100%)					
OUTPUT VOLTAGE SETTING[V]	3.21 - 3.42	4.90 - 5.21	11.64 - 12.36	14.55 - 15.45		
PROTECTION CIRCUIT AND OTHERS	OVERCURRENT PROTECTION	Works over 105% of rating and recovers automatically				
	REMOTE ON/OFF	Provided (Negative logic L : ON, H : OFF)				

MODEL	MGFS6483R3	MGFS64805	MGFS64812	MGFS64815
MAX OUTPUT WATTAGE[W]	5.28	6.0	6.0	6.0
DC OUTPUT	VOLTAGE[V]	3.3	5	12
	CURRENT[A]	1.6	1.2	0.5

SPECIFICATIONS

	MODEL	MGFS6483R3	MGFS64805	MGFS64812	MGFS64815	
INPUT	VOLTAGE[V]	DC18 - 76 (Surge voltage 100V, 100ms max)				
	CURRENT[A]	*1 0.14typ	0.15typ	0.15typ	0.15typ	
	EFFICIENCY[%]	*1 80typ	84typ	88typ	88typ	
OUTPUT	VOLTAGE[V]	3.3	5	12	15	
	CURRENT[A]	1.6	1.2	0.5	0.4	
	LINE REGULATION[mV]	20max	20max	48max	60max	
	LOAD REGULATION[mV]	20max	20max	48max	60max	
	RIPPLE[mVp-p]	Io=30% -	75max	75max	100max	100max
		Io=0 - 30%	*2 225max	225max	300max	300max
	RIPPLE NOISE[mVp-p]	Io=30% -	120max	120max	150max	150max
		Io=0 - 30%	*2 300max	300max	400max	400max
	TEMPERATURE REGULATION[mV]	-20 to +65°C	50max	50max	150max	180max
		-40 to +65°C	80max	80max	240max	290max
	DRIFT[mV]	*3 20max	20max	48max	60max	
START-UP TIME[ms]	30max (Minimum input, Io=100%)					
OUTPUT VOLTAGE SETTING[V]	3.21 - 3.42	4.90 - 5.21	11.64 - 12.36	14.55 - 15.45		
PROTECTION CIRCUIT AND OTHERS	OVERCURRENT PROTECTION	Works over 105% of rating and recovers automatically				
	REMOTE ON/OFF	Provided (Negative logic L : ON, H : OFF)				

GENERAL SPECIFICATIONS

ISOLATION	INPUT-OUTPUT	DC1,500V or AC1,000V 1minute, Cutoff current=10mA, DC500V 1,000MΩ min (20±15°C)
ENVIRONMENT	OPERATING TEMP., HUMID. AND ALTITUDE	-40 to +85°C, 20 to 95%RH (Non condensing) (Refer to "Derating"), 5,000m (16,400feet) max
	STORAGE TEMP., HUMID. AND ALTITUDE	-40 to +100°C, 20 to 95%RH (Non condensing), 9,000m (30,000feet) max
	VIBRATION	10 - 55Hz 98.0m/s ² (10G), 3minute period, 60minutes each along X, Y and Z axis
	IMPACT	490.3m/s ² (50G) 11ms, once each along X, Y and Z axis
SAFETY	AGENCY APPROVALS	UL60950-1, C-UL, EN62368-1
OTHERS	CASE SIZE/WEIGHT	22.0×12.0×9.5mm [0.87×0.48×0.38 inches] (W×H×D) / 7g max
	COOLING METHOD	Convection/Forced air

- *1 Rated input 24V or 48V DC I_o=100%
- *2 Ripple and ripple noise is measured by using test board with ceramic capacitor 1μF at 50mm from output pins.
- *3 Drift is the DC output accuracy for eight hours period after a half-hour warm-up at 25°C.
- * Parallel operation with other model is not possible.
- * MGFW6xx12/MGFW6xx15 is available as single output, +24V/+30V

External view

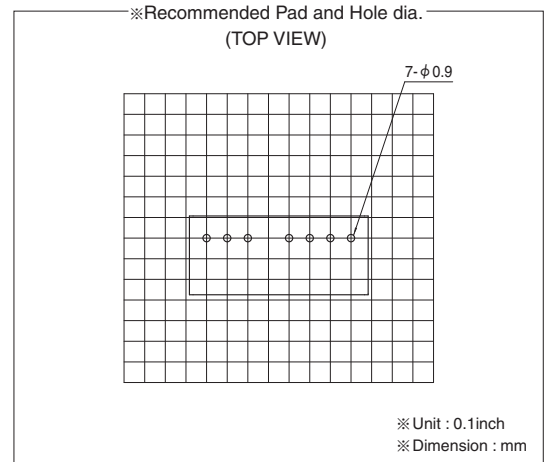
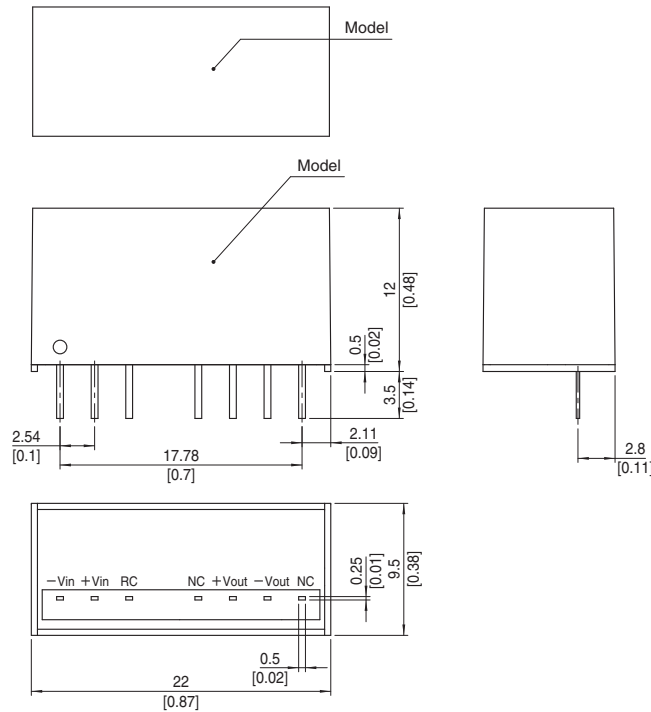

- ※ Tolerance ±0.5 [±0.02]
- ※ Dimensions in mm, []= inches
- ※ Pin terminal material : Copper
- ※ Planting treatment of terminal : Lead free plating
- ※ Case material : PBT
- ※ Weight 7g max

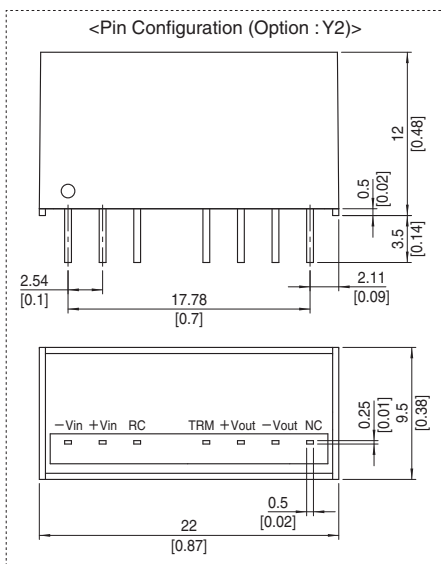

MGFW6

MGFW62412-□

① ② ③ ④ ⑤ ⑥

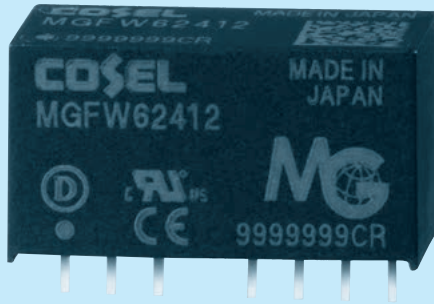

- ① Series name
- ② Dual output
- ③ Output wattage
- ④ Input voltage
- ⑤ Output voltage
- ⑥ Optional
- Y2: Output voltage adjustable (+10%, -5%)

MODEL	MGFW62412	MGFW62415	MGFW64812	MGFW64815
MAX OUTPUT WATTAGE[W]	6.00	6.00	6.00	6.00
DC OUTPUT	VOLTAGE[V] *1	±12 or +24	±15 or +30	±15 or +30
	CURRENT[A]	0.25	0.2	0.25

SPECIFICATIONS

	MODEL	MGFW62412	MGFW62415	MGFW64812	MGFW64815	
INPUT	VOLTAGE[V]	DC9 - 36 (Surge voltage 50V,100ms max)		DC18 - 76 (Surge voltage 100V,100ms max)		
	CURRENT[A] *2	0.29typ	0.29typ	0.15typ	0.15typ	
	EFFICIENCY[%] *2	87typ	88typ	88typ	88typ	
OUTPUT	VOLTAGE[V]	±12 (+24)	±15 (+30)	±12 (+24)	±15 (+30)	
	CURRENT[A]	0.25	0.2	0.25	0.2	
	LINE REGULATION[mV]	60max	75max	60max	75max	
	LOAD REGULATION[mV]	*3	480max	600max	480max	600max
		*4	600max	750max	600max	750max
	RIPPLE[mVp-p] *5	Po=30% -	120max	120max	120max	120max
		Po=0 - 30%	360max	360max	360max	360max
	RIPPLE NOISE[mVp-p] *5	Po=30% -	200max	200max	200max	200max
		Po=0 - 30%	500max	500max	500max	500max
	TEMPERATURE REGULATION[mV]	-20 to +75°C	190max	230max	190max	230max
	-40 to +75°C	300max	360max	300max	360max	
DRIFT[mV] *6		48max	60max	48max	60max	
START-UP TIME[ms]		30max (Minimum input, Io=100%)				
OUTPUT VOLTAGE SETTING[V]		11.64 - 12.36	14.55 - 15.45	11.64 - 12.36	14.55 - 15.45	
PROTECTION CIRCUIT AND OTHERS	OVERCURRENT PROTECTION	Works over 105% of rating and recovers automatically				
	REMOTE ON/OFF	Provided (Negative logic L : ON, H : OFF)				
ISOLATION	INPUT-OUTPUT	DC1,500V or AC1,000V 1minute, Cutoff current=10mA, DC500V 1,000MΩ min (20±15°C)				
ENVIRONMENT	OPERATING TEMP.,HUMID.AND ALTITUDE	-40 to +85°C, 20 to 95%RH (Non condensing) (Refer to "Derating"), 5,000m (16,400feet) max				
	STORAGE TEMP.,HUMID.AND ALTITUDE	-40 to +100°C, 20 to 95%RH (Non condensing), 9,000m (30,000feet) max				
	VIBRATION	10 - 55Hz 98.0m/s ² (10G), 3minute period, 60minutes each along X, Y and Z axis				
	IMPACT	490.3m/s ² (50G) 11ms, once each along X, Y and Z axis				
SAFETY	AGENCY APPROVALS	UL60950-1, C-UL, EN62368-1				
OTHERS	CASE SIZE/WEIGHT	22.0×12.0×9.5mm [0.87×0.48×0.38 inches] (W×H×D) / 7g max				
	COOLING METHOD	Convection/Forced air				

*1 Single output +24V, +30V with no use of COM.
 *2 Rated input 5V, 12V, 24V or 48V DC Io=100%
 *3 Symmetrical loading from 20% to 100%.
 *4 Symmetrical loading from 0% to 100%.
 *5 Ripple and Ripple Noise is measured by using test board with ceramic capacitor 1μF at 50mm from output pins. Po:Output wattage.
 *6 Drift is the DC output accuracy for eight hours period after a half-hour warm-up at 25°C.
 * Parallel operation with other model is not possible.

External view

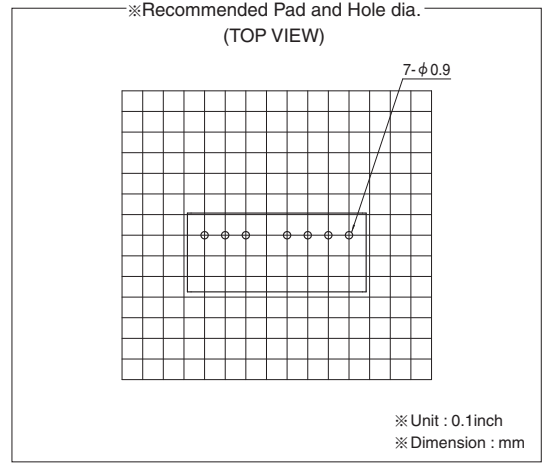
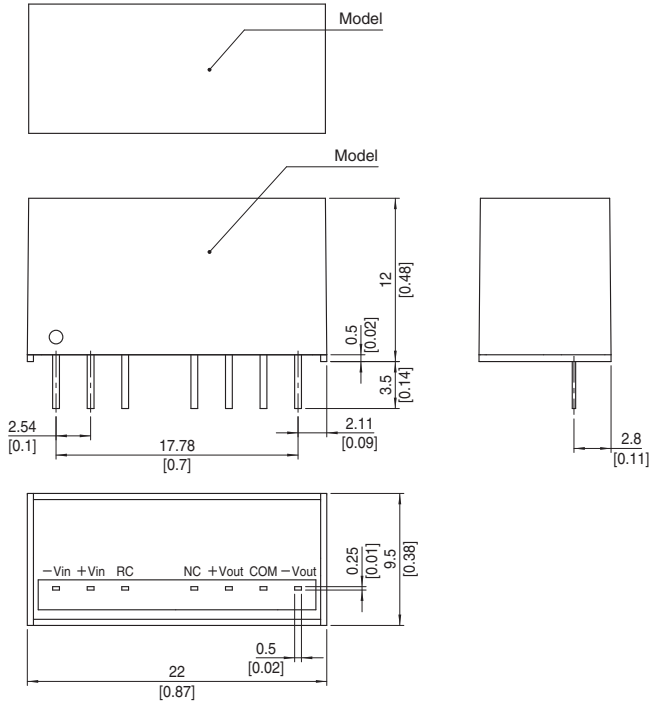

- ※ Tolerance ± 0.5 [± 0.02]
- ※ Dimensions in mm, []= inches
- ※ Pin terminal material : Copper
- ※ Planting treatment of terminal : Lead free plating
- ※ Case material : PBT
- ※ Weight 7g max

MG

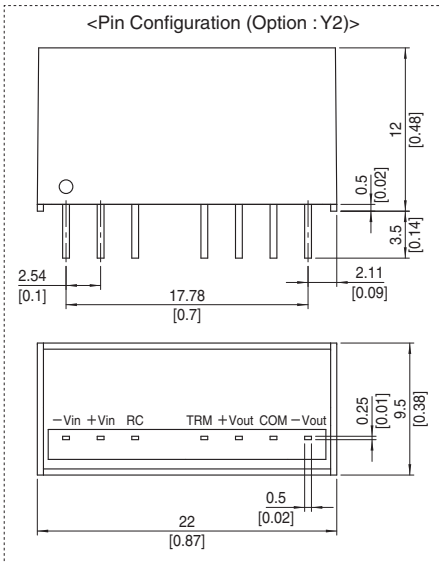

MGFS10

MGF S 10 24 05 -□

① ② ③ ④ ⑤ ⑥

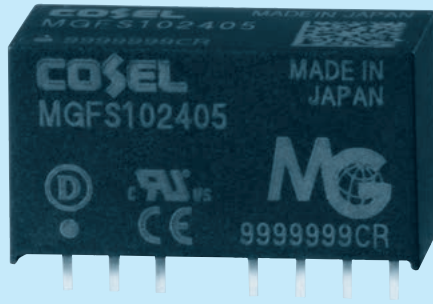

- ① Series name
- ② Single output
- ③ Output wattage
- ④ Input voltage
- ⑤ Output voltage
- ⑥ Optional
- Y2: Output voltage adjustable (+10%, -5%)

MODEL	MGFS10243R3	MGFS102405	MGFS102412	MGFS102415
MAX OUTPUT WATTAGE[W]	8.58	10.0	10.8	10.5
DC OUTPUT	VOLTAGE[V]	3.3	5	12
	CURRENT[A]	2.6	2.0	0.9

SPECIFICATIONS

	MODEL	MGFS10243R3	MGFS102405	MGFS102412	MGFS102415	
INPUT	VOLTAGE[V]	DC9 - 36 (Surge voltage 50V,100ms max) (Refer to "Derating" for input voltage derating.)				
	CURRENT[A]	*1 0.42typ	0.48typ	0.51typ	0.50typ	
	EFFICIENCY[%]	*1 86typ	88typ	89typ	89typ	
OUTPUT	VOLTAGE[V]	3.3	5	12	15	
	CURRENT[A]	2.6	2.0	0.9	0.7	
	LINE REGULATION[mV]	20max	20max	48max	60max	
	LOAD REGULATION[mV]	20max	20max	48max	60max	
	RIPPLE[mVp-p]	*2	Io=30% -	75max	75max	100max
			Io=0 - 30%	225max	225max	300max
	RIPPLE NOISE[mVp-p]	*2	Io=30% -	120max	120max	150max
			Io=0 - 30%	300max	300max	400max
	TEMPERATURE REGULATION[mV]	*3	-20 to +55°C	50max	50max	150max
			-40 to +55°C	80max	80max	240max
DRIFT[mV]		20max	20max	48max	60max	
START-UP TIME[ms]		30max (Minimum input, Io=100%)				
OUTPUT VOLTAGE SETTING[V]		3.21 - 3.42	4.90 - 5.21	11.64 - 12.36	14.55 - 15.45	
PROTECTION CIRCUIT AND OTHERS	OVERCURRENT PROTECTION	Works over 105% of rating and recovers automatically				
	REMOTE ON/OFF	Provided (Negative logic L : ON, H : OFF)				

MODEL	MGFS10483R3	MGFS104805	MGFS104812	MGFS104815
MAX OUTPUT WATTAGE[W]	8.58	10.0	10.8	10.5
DC OUTPUT	VOLTAGE[V]	3.3	5	12
	CURRENT[A]	2.6	2.0	0.9

SPECIFICATIONS

	MODEL	MGFS10483R3	MGFS104805	MGFS104812	MGFS104815	
INPUT	VOLTAGE[V]	DC18 - 76 (Surge voltage 100V,100ms max) (Refer to "Derating" for input voltage derating.)				
	CURRENT[A]	*1 0.21typ	0.24typ	0.26typ	0.25typ	
	EFFICIENCY[%]	*1 86typ	88typ	89typ	89typ	
OUTPUT	VOLTAGE[V]	3.3	5	12	15	
	CURRENT[A]	2.6	2.0	0.9	0.7	
	LINE REGULATION[mV]	20max	20max	48max	60max	
	LOAD REGULATION[mV]	20max	20max	48max	60max	
	RIPPLE[mVp-p]	*2	Io=30% -	75max	75max	100max
			Io=0 - 30%	225max	225max	300max
	RIPPLE NOISE[mVp-p]	*2	Io=30% -	120max	120max	150max
			Io=0 - 30%	300max	300max	400max
	TEMPERATURE REGULATION[mV]	*3	-20 to +55°C	50max	50max	150max
			-40 to +55°C	80max	80max	240max
DRIFT[mV]		20max	20max	48max	60max	
START-UP TIME[ms]		30max (Minimum input, Io=100%)				
OUTPUT VOLTAGE SETTING[V]		3.21 - 3.42	4.90 - 5.21	11.64 - 12.36	14.55 - 15.45	
PROTECTION CIRCUIT AND OTHERS	OVERCURRENT PROTECTION	Works over 105% of rating and recovers automatically				
	REMOTE ON/OFF	Provided (Negative logic L : ON, H : OFF)				

GENERAL SPECIFICATIONS

ISOLATION	INPUT-OUTPUT	DC1,500V or AC1,000V 1minute, Cutoff current=10mA, DC500V 1,000MΩ min (20±15°C)
ENVIRONMENT	OPERATING TEMP., HUMID. AND ALTITUDE	-40 to +85°C, 20 to 95%RH (Non condensing) (Refer to "Derating"), 5,000m (16,400feet) max
	STORAGE TEMP., HUMID. AND ALTITUDE	-40 to +100°C, 20 to 95%RH (Non condensing), 9,000m (30,000feet) max
	VIBRATION	10 - 55Hz 98.0m/s ² (10G), 3minute period, 60minutes each along X, Y and Z axis
	IMPACT	490.3m/s ² (50G) 11ms, once each along X, Y and Z axis
SAFETY	AGENCY APPROVALS	UL60950-1, C-UL, EN62368-1
OTHERS	CASE SIZE/WEIGHT	22.0×12.0×9.5mm [0.87×0.48×0.38 inches] (W×H×D) / 7g max
	COOLING METHOD	Convection/Forced air

- *1 Rated input 24V or 48V DC I_o=100%
- *2 Ripple and ripple noise is measured by using test board with ceramic capacitor 1μF at 50mm from output pins.
- *3 Drift is the DC output accuracy for eight hours period after a half-hour warm-up at 25°C.
- * Parallel operation with other model is not possible.
- * MGFW10xx12/MGFW10xx15 is available as single output, +24V/+30V

External view

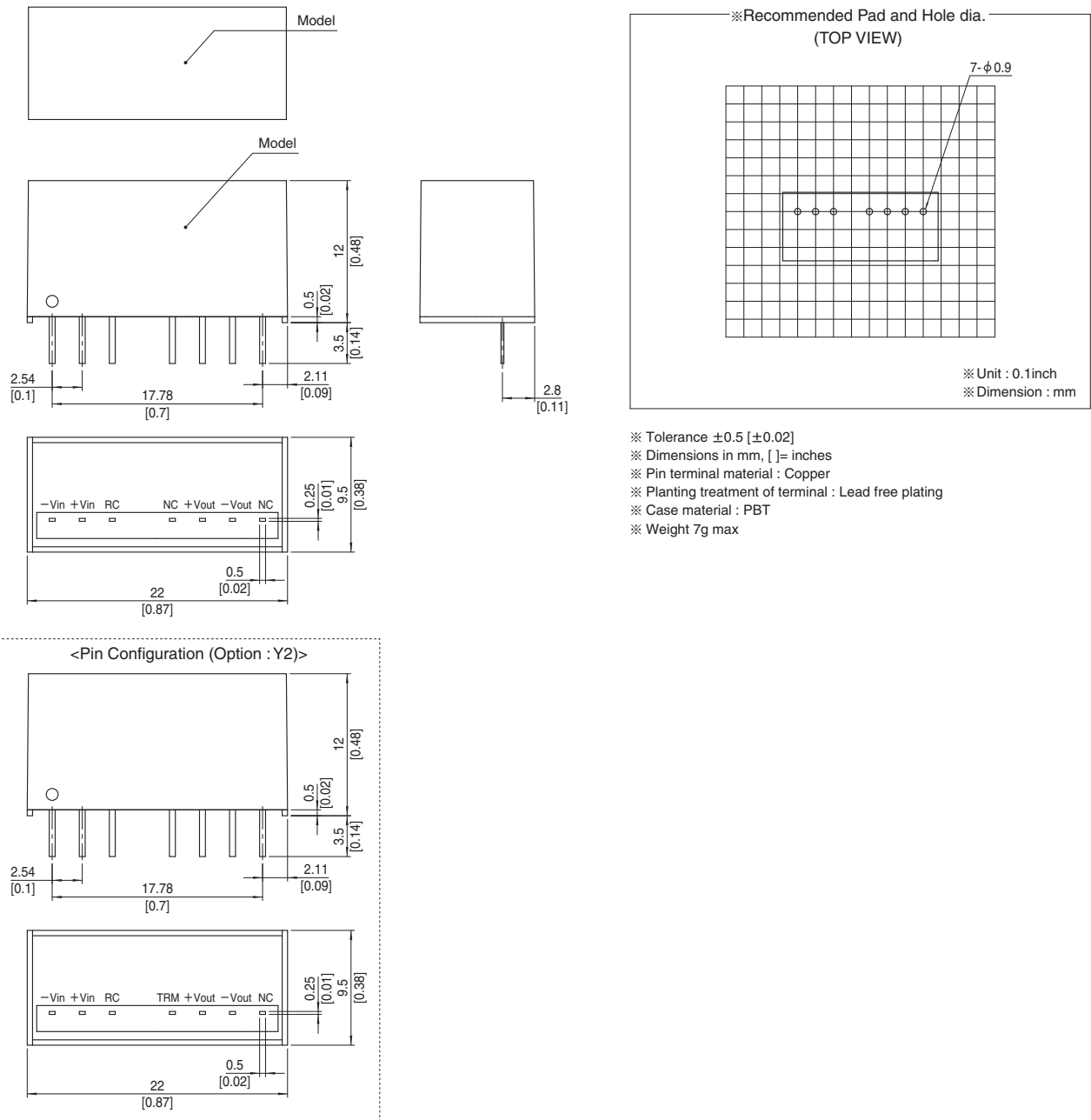

MG

MGFW10

MGF W 10 24 12 - □

① ② ③ ④ ⑤ ⑥

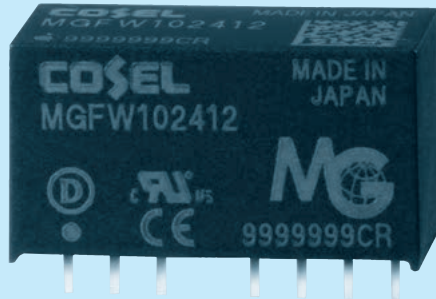

- ① Series name
- ② Dual output
- ③ Output wattage
- ④ Input voltage
- ⑤ Output voltage
- ⑥ Optional
- Y2: Output voltage adjustable (+10%, -5%)

MG

MODEL	MGFW102412	MGFW102415	MGFW104812	MGFW104815
MAX OUTPUT WATTAGE[W]	10.08	10.20	10.08	10.20
DC OUTPUT	VOLTAGE[V] *1	±12 or +24	±15 or +30	±12 or +24
	CURRENT[A]	0.42	0.34	0.42

SPECIFICATIONS

	MODEL	MGFW102412	MGFW102415	MGFW104812	MGFW104815	
INPUT	VOLTAGE[V]	DC9 - 36 (Surge voltage 50V,100ms max) (Refer to "Derating" for input voltage derating.)		DC18 - 76 (Surge voltage 100V,100ms max) (Refer to "Derating" for input voltage derating.)		
	CURRENT[A] *2	0.49typ	0.49typ	0.25typ	0.25typ	
	EFFICIENCY[%] *2	87typ	87typ	87typ	88typ	
OUTPUT	VOLTAGE[V]	±12 (+24)	±15 (+30)	±12 (+24)	±15 (+30)	
	CURRENT[A]	0.42	0.34	0.42	0.34	
	LINE REGULATION[mV]	60max	75max	60max	75max	
	LOAD REGULATION[mV]	*3	480max	600max	480max	600max
		*4	600max	750max	600max	750max
	RIPPLE[mVp-p]	Po=30% - *5	120max	120max	120max	120max
		Po=0 - 30%	360max	360max	360max	360max
	RIPPLE NOISE[mVp-p]	Po=30% - *5	200max	200max	200max	200max
		Po=0 - 30%	500max	500max	500max	500max
	TEMPERATURE REGULATION[mV]	-20 to +50°C	150max	180max	150max	180max
-40 to +50°C		240max	290max	240max	290max	
DRIFT[mV] *6	48max	60max	48max	60max		
START-UP TIME[ms]	30max (Minimum input, Io=100%)					
OUTPUT VOLTAGE SETTING[V]	11.64 - 12.36	14.55 - 15.45	11.64 - 12.36	14.55 - 15.45		
PROTECTION CIRCUIT AND OTHERS	OVERCURRENT PROTECTION	Works over 105% of rating and recovers automatically				
	REMOTE ON/OFF	Provided (Negative logic L : ON, H : OFF)				
ISOLATION	INPUT-OUTPUT	DC1,500V or AC1,000V 1minute, Cutoff current=10mA, DC500V 1,000MΩ min (20±15°C)				
ENVIRONMENT	OPERATING TEMP., HUMID. AND ALTITUDE	-40 to +85°C, 20 to 95%RH (Non condensing) (Refer to "Derating"), 5,000m (16,400feet) max				
	STORAGE TEMP., HUMID. AND ALTITUDE	-40 to +100°C, 20 to 95%RH (Non condensing), 9,000m (30,000feet) max				
	VIBRATION	10 - 55Hz 98.0m/s ² (10G), 3minute period, 60minutes each along X, Y and Z axis				
	IMPACT	490.3m/s ² (50G) 11ms, once each along X, Y and Z axis				
SAFETY	AGENCY APPROVALS	UL60950-1, C-UL, EN62368-1				
OTHERS	CASE SIZE/WEIGHT	22.0x12.0x9.5mm [0.87x0.48x0.38 inches] / 7g max				
	COOLING METHOD	Convection/Forced air				

- *1 Single output +24V, +30V with no use of COM.
- *2 Rated input 5V, 12V, 24V or 48V DC Io=100%
- *3 Symmetrical loading from 20% to 100%.
- *4 Symmetrical loading from 0% to 100%.
- *5 Ripple and Ripple Noise is measured by using test board with ceramic capacitor 1μF at 50mm from output pins. Po:Output wattage.
- *6 Drift is the DC output accuracy for eight hours period after a half-hour warm-up at 25°C.
- * Parallel operation with other model is not possible.

External view

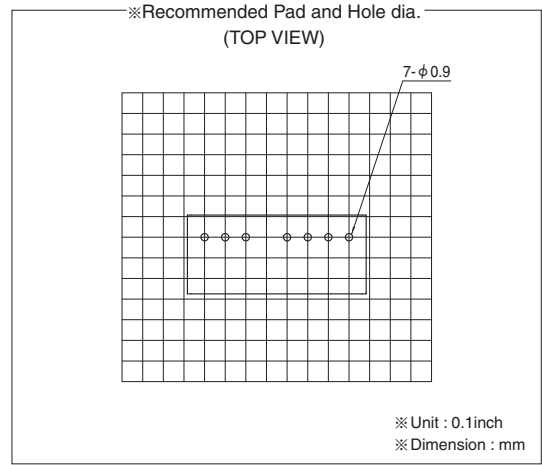
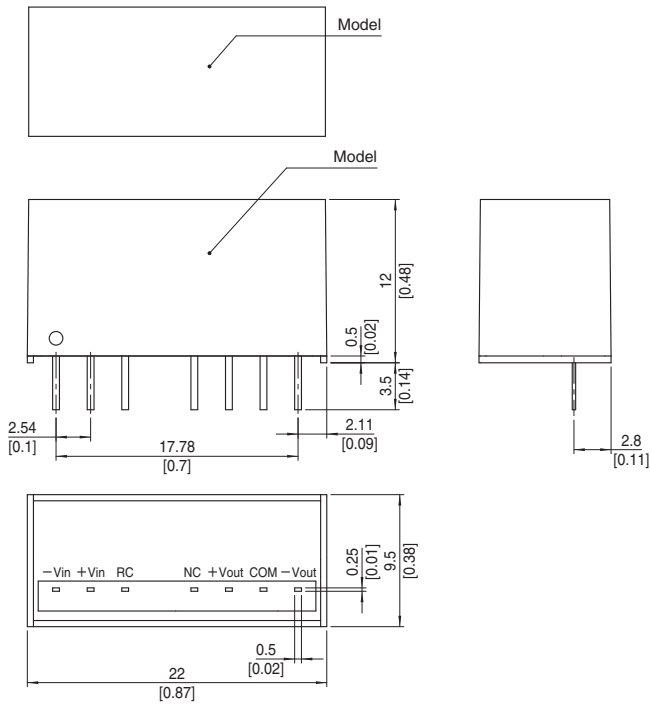

- ※ Tolerance ± 0.5 [± 0.02]
- ※ Dimensions in mm, []= inches
- ※ Pin terminal material : Copper
- ※ Planting treatment of terminal : Lead free plating
- ※ Case material : PBT
- ※ Weight 7g max

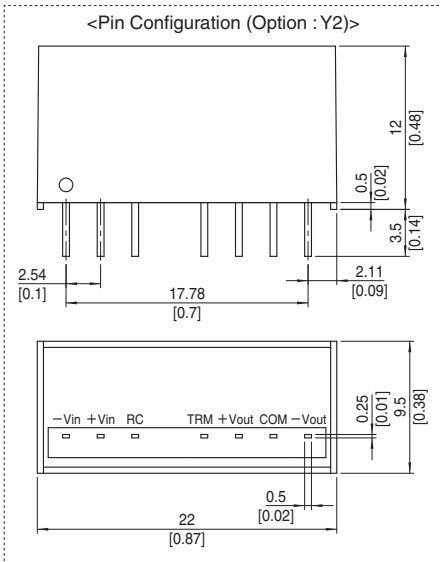

MGXS1R5

MGX S 1R5 24 05 -□

① ② ③ ④ ⑤ ⑥

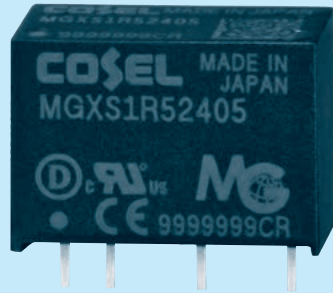

- ① Series name
- ② Single output
- ③ Output wattage
- ④ Input voltage
- ⑤ Output voltage
- ⑥ Optional
- Y2: Output voltage adjustable (+10%, -5%)

MODEL	MGXS1R5243R3	MGXS1R52405	MGXS1R52412	MGXS1R52415
MAX OUTPUT WATTAGE[W]	1.32	1.50	1.56	1.50
DC OUTPUT	VOLTAGE[V]	3.3	5	12
	CURRENT[A]	0.4	0.3	0.13

SPECIFICATIONS

	MODEL	MGXS1R5243R3	MGXS1R52405	MGXS1R52412	MGXS1R52415	
INPUT	VOLTAGE[V]	DC6 - 60 (Surge voltage 76V, 100ms max) (Refer to "Derating" for input voltage derating.)				
	CURRENT[A]	*1 0.072typ	0.080typ	0.080typ	0.077typ	
	EFFICIENCY[%]	*1 77typ	79typ	82typ	82typ	
OUTPUT	VOLTAGE[V]	3.3	5	12	15	
	CURRENT[A]	0.4	0.3	0.13	0.1	
	LINE REGULATION[mV]	20max	20max	48max	60max	
	LOAD REGULATION[mV]	20max	20max	48max	60max	
	RIPPLE[mVp-p]	*2 120max	120max	150max	150max	
	RIPPLE NOISE[mVp-p]	*2 200max	200max	200max	200max	
	TEMPERATURE REGULATION[mV]	-20 to +85°C	50max	50max	150max	180max
		-40 to +85°C	80max	80max	240max	290max
	DRIFT[mV]	*3 20max	20max	48max	60max	
	START-UP TIME[ms]	30max				
OUTPUT VOLTAGE SETTING[V]	3.21 - 3.42	4.90 - 5.21	11.64 - 12.36	14.55 - 15.45		
PROTECTION CIRCUIT	OVERCURRENT PROTECTION	Works over 105% of rating and recovers automatically				

GENERAL SPECIFICATIONS

ISOLATION	INPUT-OUTPUT	DC1,500V or AC1,000V 1minute, Cutoff current=10mA, DC500V 1,000MΩ min (20±15°C)
ENVIRONMENT	OPERATING TEMP., HUMID. AND ALTITUDE	-40 to +85°C, 20 to 95%RH (Non condensing) (Refer to "Derating"), 5,000m (16,400feet) max
	STORAGE TEMP., HUMID. AND ALTITUDE	-40 to +100°C, 20 to 95%RH (Non condensing), 9,000m (30,000feet) max
	VIBRATION	10 - 55Hz 98.0m/s ² (10G), 3minute period, 60minutes each along X, Y and Z axis
	IMPACT	490.3m/s ² (50G) 11ms, once each along X, Y and Z axis
SAFETY	AGENCY APPROVALS	UL60950-1, C-UL, EN62368-1
OTHERS	CASE SIZE/WEIGHT	17.0×12.0×8.5mm [0.67×0.48×0.34 inches] (W×H×D) / 4g max
	COOLING METHOD	Convection/Forced air

- *1 Rated input 24V DC I_o=100%
- *2 Ripple and ripple noise is measured by using test board with ceramic capacitor 1μF at 50mm from output pins.
- *3 Drift is the DC output accuracy for eight hours period after a half-hour warm-up at 25°C.
- * Parallel operation with other model is not possible.
- * MGXW1R52412/MGXW1R52415 is available as single output, +24V/+30V

External view

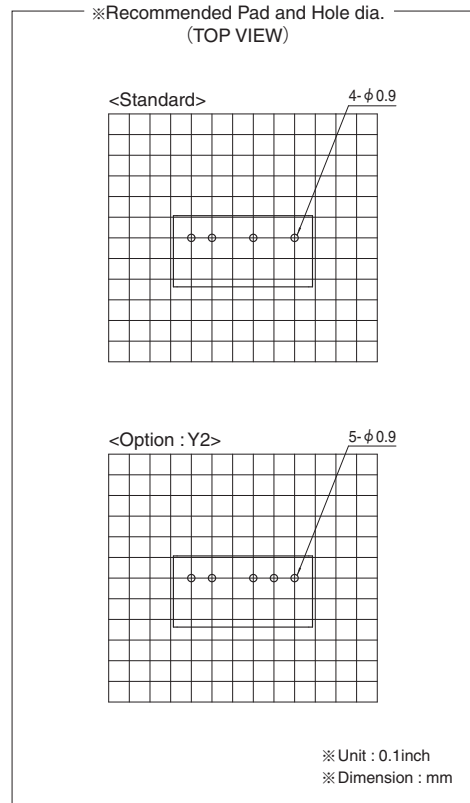
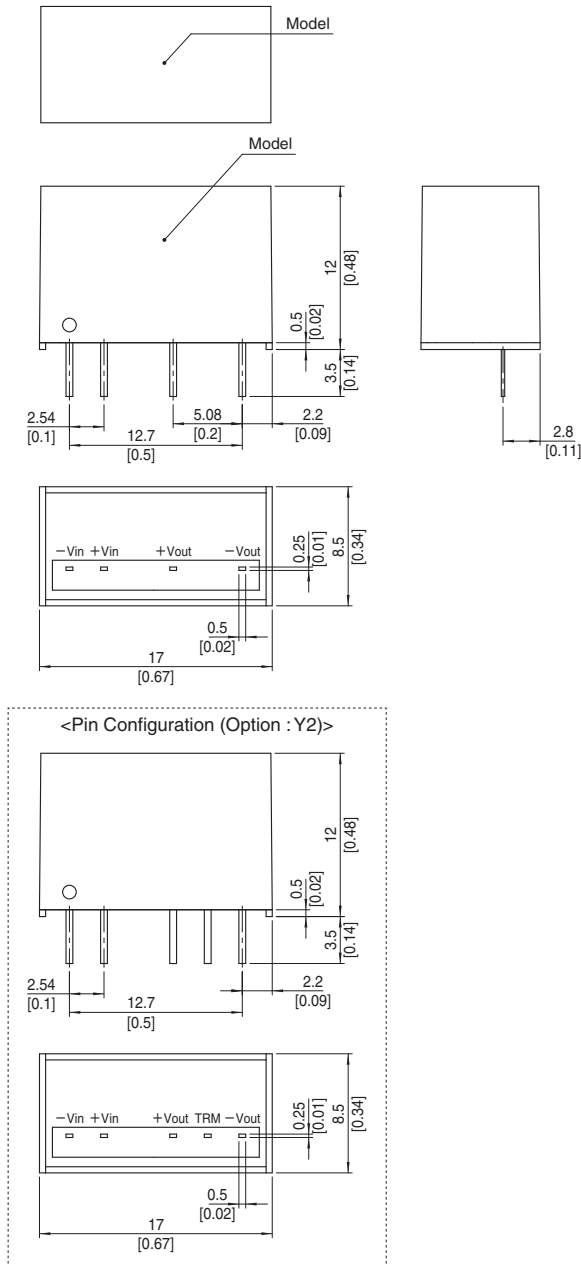

- ※ Tolerance ± 0.5 [± 0.02]
- ※ Dimensions in mm, []= inches
- ※ Pin terminal material : Copper
- ※ Plating treatment of terminal : Lead free plating
- ※ Case material : PBT
- ※ Weight 4g max

MGXW1R5

MGX W 1R5 24 12 -□

① ② ③ ④ ⑤ ⑥

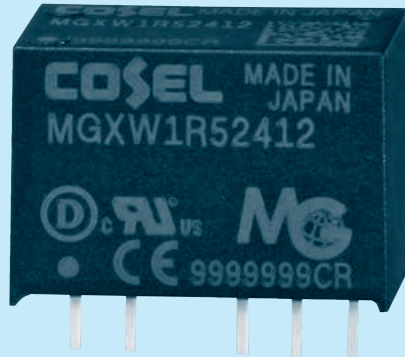

- ① Series name
- ② Dual output
- ③ Output wattage
- ④ Input voltage
- ⑤ Output voltage
- ⑥ Optional

MG

MODEL	MGXW1R52412	MGXW1R52415
MAX OUTPUT WATTAGE[W]	1.56	1.50
DC OUTPUT	VOLTAGE[V] *1	±12 or +24
	CURRENT[A]	0.065

SPECIFICATIONS

	MODEL	MGXW1R52412	MGXW1R52415	
INPUT	VOLTAGE[V]	DC6 - 60 (Surge voltage 76V, 100ms max) (Refer to "Derating" for input voltage derating.)		
	CURRENT[A] *2	0.082typ	0.079typ	
	EFFICIENCY[%] *2	80typ	80typ	
OUTPUT	VOLTAGE[V]	±12 (+24)	±15 (+30)	
	CURRENT[A]	0.065	0.05	
	LINE REGULATION[mV]	60max	75max	
	LOAD REGULATION[mV]	*3	480max	600max
		*4	600max	750max
	RIPPLE[mVp-p] *5	150max	150max	
	RIPPLE NOISE[mVp-p] *5	200max	200max	
	TEMPERATURE REGULATION[mV]	-20 to +85°C	210max	260max
		-40 to +85°C	320max	390max
	DRIFT[mV] *6	48max	60max	
START-UP TIME[ms]	30max			
OUTPUT VOLTAGE SETTING[V]	11.64 - 12.36	14.55 - 15.45		
PROTECTION CIRCUIT	OVERCURRENT PROTECTION	Works over 105% of rating and recovers automatically		

GENERAL SPECIFICATIONS

ISOLATION	INPUT-OUTPUT	DC1,500V or AC1,000V 1minute, Cutoff current=10mA, DC500V 1,000MΩ min (20±15°C)
ENVIRONMENT	OPERATING TEMP., HUMID. AND ALTITUDE	-40 to +85°C, 20 to 95%RH (Non condensing) (Refer to "Derating"), 5,000m (16,400feet) max
	STORAGE TEMP., HUMID. AND ALTITUDE	-40 to +100°C, 20 to 95%RH (Non condensing), 9,000m (30,000feet) max
	VIBRATION	10 - 55Hz 98.0m/s ² (10G), 3minute period, 60minutes each along X, Y and Z axis
	IMPACT	490.3m/s ² (50G) 11ms, once each along X, Y and Z axis
SAFETY	AGENCY APPROVALS	UL60950-1, C-UL, EN62368-1
OTHERS	CASE SIZE/WEIGHT	17.0 × 12.0 × 8.5mm [0.67 × 0.48 × 0.34 inches] (W × H × D) / 4g max
	COOLING METHOD	Convection/Forced air

- *1 Single output +24V, +30V with no use of COM.
- *2 Rated input 24V DC I_o=100%
- *3 Symmetrical loading from 20% to 100%.
- *4 Symmetrical loading from 0% to 100%.
- *5 Ripple and Ripple Noise is measured by using test board with ceramic capacitor 1μF at 50mm from output pins. (20MHz Oscilloscope)
- *6 Drift is the DC output accuracy for eight hours period after a half-hour warm-up at 25°C.
- * Parallel operation with other model is not possible.

External view

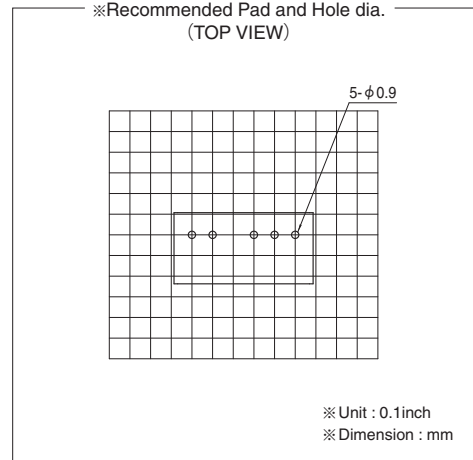
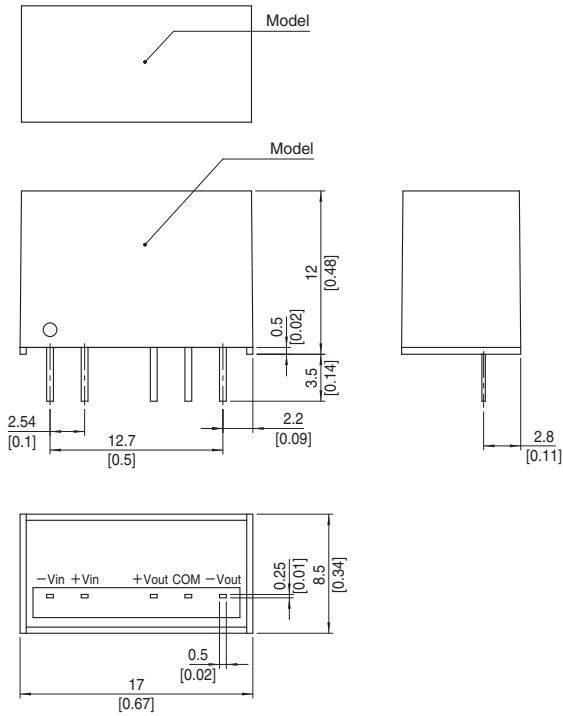

- ※ Tolerance ± 0.5 [± 0.02]
- ※ Dimensions in mm, []= inches
- ※ Pin terminal material : Copper
- ※ Planting treatment of terminal : Lead free plating
- ※ Case material : PBT
- ※ Weight 4g max

MG

MGXS6

MGX S 6 24 05 -□

① ② ③ ④ ⑤ ⑥

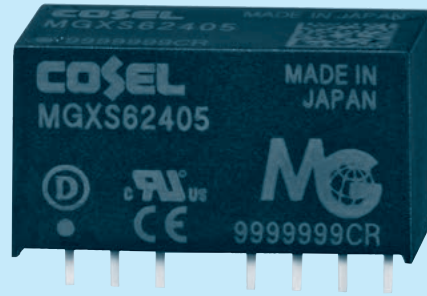

- ① Series name
- ② Single output
- ③ Output wattage
- ④ Input voltage
- ⑤ Output voltage
- ⑥ Optional
- Y2: Output voltage adjustable (+10%, -5%)

MODEL	MGXS6243R3	MGXS62405	MGXS62412	MGXS62415
MAX OUTPUT WATTAGE[W]	5.28	6.0	6.0	6.0
DC OUTPUT	VOLTAGE[V]	3.3	5	12
	CURRENT[A]	1.6	1.2	0.5

SPECIFICATIONS

	MODEL	MGXS6243R3	MGXS62405	MGXS62412	MGXS62415	
INPUT	VOLTAGE[V]	DC6 - 60 (Surge voltage 76V, 100ms max) (Refer to "Derating" for input voltage derating.)				
	CURRENT[A]	*1 0.26typ	0.29typ	0.29typ	0.29typ	
	EFFICIENCY[%]	*1 85typ	88typ	87typ	87typ	
OUTPUT	VOLTAGE[V]	3.3	5	12	15	
	CURRENT[A]	1.6	1.2	0.5	0.4	
	LINE REGULATION[mV]	20max	20max	48max	60max	
	LOAD REGULATION[mV]	20max	20max	48max	60max	
	RIPPLE[mVp-p]	Io=30% -	75max	75max	100max	100max
		Io=0 - 30%	225max	225max	300max	300max
		Vin=DC48 - 60V	225max	225max	300max	300max
	RIPPLE NOISE[mVp-p]	Io=30% -	120max	120max	150max	150max
		Io=0 - 30%	300max	300max	400max	400max
		Vin=DC48 - 60V	300max	300max	400max	400max
	TEMPERATURE REGULATION[mV]	-20 to +75°C	50max	50max	150max	180max
	-40 to +75°C	80max	80max	240max	290max	
DRIFT[mV]	*3	20max	20max	48max	60max	
START-UP TIME[ms]		30max				
OUTPUT VOLTAGE SETTING[V]		3.21 - 3.42	4.90 - 5.21	11.64 - 12.36	14.55 - 15.45	
PROTECTION CIRCUIT AND OTHERS	OVERCURRENT PROTECTION	Works over 105% of rating and recovers automatically				
	REMOTE ON/OFF	Provided (Negative logic L : ON, H : OFF)				

GENERAL SPECIFICATIONS

ISOLATION	INPUT-OUTPUT	DC1,500V or AC1,000V 1minute, Cutoff current=10mA, DC500V 1,000MΩ min (20±15°C)
ENVIRONMENT	OPERATING TEMP., HUMID. AND ALTITUDE	-40 to +85°C, 20 to 95%RH (Non condensing) (Refer to "Derating"), 5,000m (16,400feet) max
	STORAGE TEMP., HUMID. AND ALTITUDE	-40 to +100°C, 20 to 95%RH (Non condensing), 9,000m (30,000feet) max
	VIBRATION	10 - 55Hz 98.0m/s ² (10G), 3minute period, 60minutes each along X, Y and Z axis
	IMPACT	490.3m/s ² (50G) 11ms, once each along X, Y and Z axis
SAFETY	AGENCY APPROVALS	UL60950-1, C-UL, EN62368-1
OTHERS	CASE SIZE/WEIGHT	22.0 × 12.0 × 9.5mm [0.87 × 0.48 × 0.38 inches] (W × H × D) / 7g max
	COOLING METHOD	Convection/Forced air

- *1 Rated input 24V DC Io=100%
- *2 Ripple and ripple noise is measured by using test board with ceramic capacitor 1μF at 50mm from output pins.
- *3 Drift is the DC output accuracy for eight hours period after a half-hour warm-up at 25°C.
- * Parallel operation with other model is not possible.
- * MGXW62412/MGXW62415 is available as single output, +24V/+30V

External view

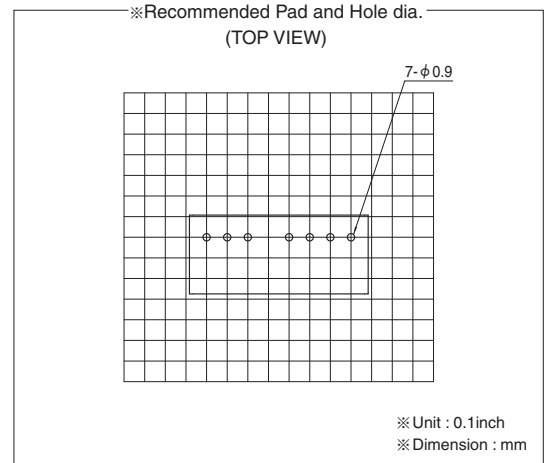
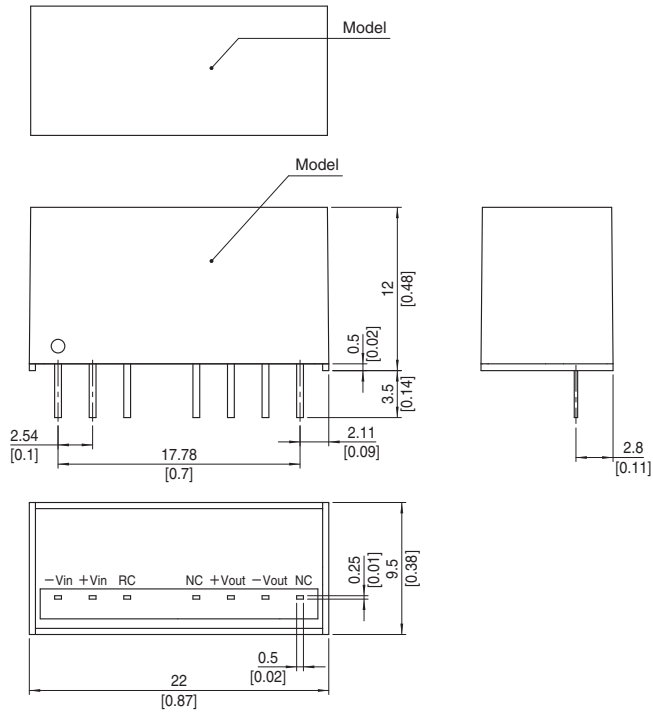

- ※ Tolerance ± 0.5 [± 0.02]
- ※ Dimensions in mm, []= inches
- ※ Pin terminal material : Copper
- ※ Plating treatment of terminal : Lead free plating
- ※ Case material : PBT
- ※ Weight 7g max

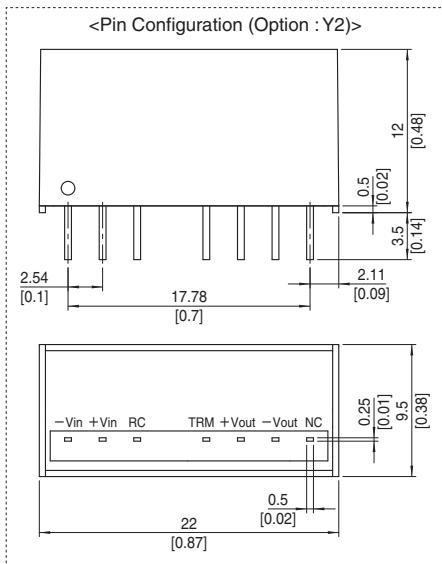

MGXW6

MGX W 6 24 12 - □

① ② ③ ④ ⑤ ⑥

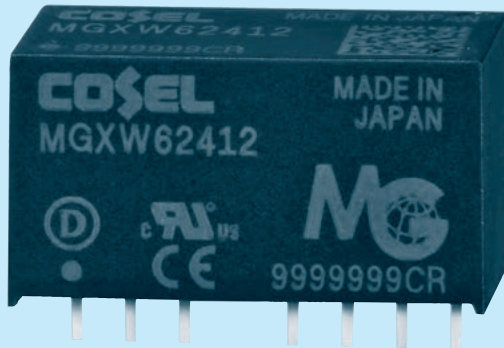

- ① Series name
- ② Dual output
- ③ Output wattage
- ④ Input voltage
- ⑤ Output voltage
- ⑥ Optional
- Y2: Output voltage adjustable (+10%, -5%)

MODEL	MGXW62412	MGXW62415
MAX OUTPUT WATTAGE[W]	6.00	6.00
DC OUTPUT	VOLTAGE[V] *1	±12 or +24
	CURRENT[A]	0.25

SPECIFICATIONS

	MODEL	MGXW62412	MGXW62415	
INPUT	VOLTAGE[V]	DC6 - 60 (Surge voltage 76V, 100ms max) (Refer to "Derating" for input voltage derating.)		
	CURRENT[A] *2	0.29typ	0.29typ	
	EFFICIENCY[%] *2	87typ	87typ	
OUTPUT	VOLTAGE[V]	±12 (+24)	±15 (+30)	
	CURRENT[A]	0.25	0.2	
	LINE REGULATION[mV]	60max	75max	
	LOAD REGULATION[mV]	*3	480max	600max
		*4	600max	750max
	RIPPLE[mVp-p] *5	Po=30% -	120max	120max
		Po=0 - 30%	480max	480max
		Vin=DC48 - 60V	480max	480max
	RIPPLE NOISE[mVp-p] *5	Po=30% -	200max	200max
		Po=0 - 30%	600max	600max
		Vin=DC48 - 60V	600max	600max
	TEMPERATURE REGULATION[mV]	-20 to +75°C	190max	230max
		-40 to +75°C	300max	360max
DRIFT[mV] *6	48max	60max		
START-UP TIME[ms]	30max			
OUTPUT VOLTAGE SETTING[V]	11.64 - 12.36	14.55 - 15.45		
PROTECTION CIRCUIT AND OTHERS	OVERCURRENT PROTECTION	Works over 105% of rating and recovers automatically		
	REMOTE ON/OFF	Provided (Negative logic L : ON, H : OFF)		

GENERAL SPECIFICATIONS

ISOLATION	INPUT-OUTPUT	DC1,500V or AC1,000V 1minute, Cutoff current=10mA, DC500V 1,000MΩ min (20±15°C)
ENVIRONMENT	OPERATING TEMP., HUMID. AND ALTITUDE	-40 to +85°C, 20 to 95%RH (Non condensing) (Refer to "Derating"), 5,000m (16,400feet) max
	STORAGE TEMP., HUMID. AND ALTITUDE	-40 to +100°C, 20 to 95%RH (Non condensing), 9,000m (30,000feet) max
	VIBRATION	10 - 55Hz 98.0m/s ² (10G), 3minute period, 60minutes each along X, Y and Z axis
	IMPACT	490.3m/s ² (50G) 11ms, once each along X, Y and Z axis
SAFETY	AGENCY APPROVALS	UL60950-1, C-UL, EN62368-1
OTHERS	CASE SIZE/WEIGHT	22.0×12.0×9.5mm [0.87×0.48×0.38 inches] (W×H×D) / 7g max
	COOLING METHOD	Convection/Forced air

*1 Single output +24V, +30V with no use of COM.
 *2 Rated input 24V DC Io=100%
 *3 Symmetrical loading from 20% to 100%.
 *4 Symmetrical loading from 0% to 100%.
 *5 Ripple and Ripple Noise is measured by using test board with ceramic capacitor 1μF at

*6 50mm from output pins. (20MHz Oscilloscope). Po: Output wattage.
 * Drift is the DC output accuracy for eight hours period after a half-hour warm-up at 25°C.
 * Parallel operation with other model is not possible.

External view

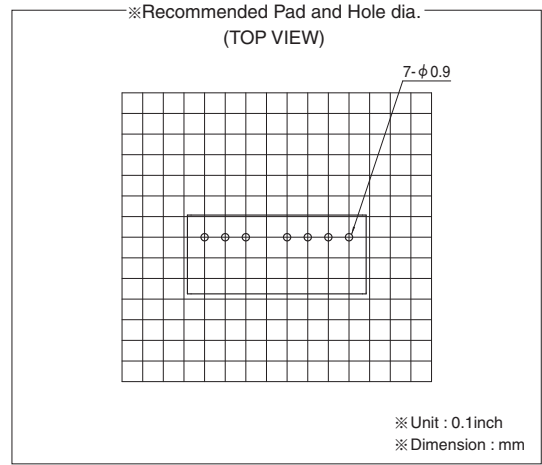
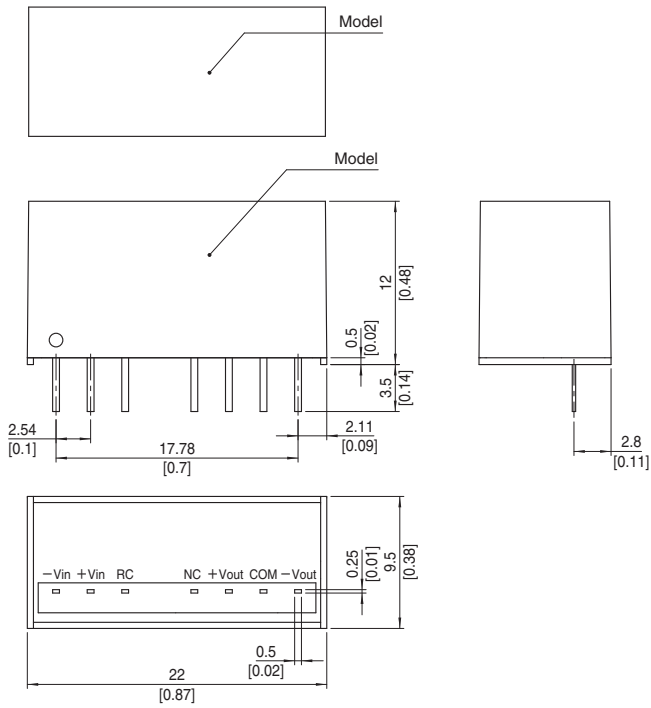

- ※ Tolerance ± 0.5 [± 0.02]
- ※ Dimensions in mm, []= inches
- ※ Pin terminal material : Copper
- ※ Plating treatment of terminal : Lead free plating
- ※ Case material : PBT
- ※ Weight 7g max

MG

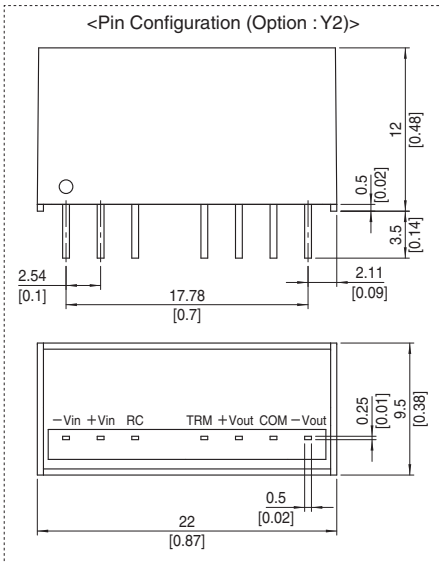

Pin configuration

●MG1R5/MG3 Single Output

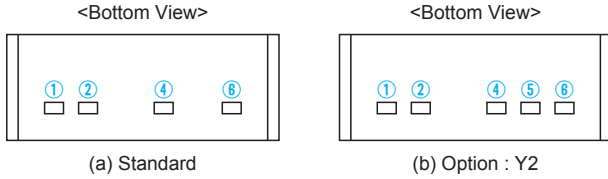

Pin No.	Pin Name	Function
①	-Vin	-DC Input
②	+Vin	+DC Input
④	+Vout	+DC Output
⑤	NP	No Pin
	TRM	Output Voltage Adjustment (Option:Refer to instruction manual 1.5)
⑥	-Vout	-DC Output

●MG1R5/MG3 Dual Output

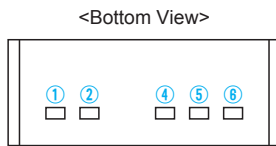

Pin No.	Pin Name	Function
①	-Vin	-DC Input
②	+Vin	+DC Input
④	+Vout	+DC Output
⑤	COM	GND of Output Voltage
⑥	-Vout	-DC Output

MG

●MG6/MG10 Single Output, Dual Output

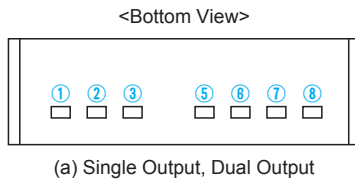

Pin No.	Pin Name	Function
①	-Vin	-DC Input
②	+Vin	+DC Input
③	RC	Remote ON/OFF
⑤	NC	No Connect
	TRM	Output Voltage Adjustment (Option:Refer to instruction manual 1.5)
⑥	+Vout	+DC Output
⑦	-Vout	-DC Output (for Single Output)
	COM	GND of Output Voltage (for Dual Output)
⑧	NC	No Connect (for Single Output)
	-Vout	-DC Output (for Dual Output)

Assembling and Installation Method

Installation

- When two or more power supplies are used side by side, position them with proper intervals to allow enough air ventilation. Ambient temperature around each power supply should not exceed the temperature range shown in "Derating".

Soldering Conditions

- (1) Flow Soldering : 260°C 15 seconds or less
- (2) Soldering Iron : maximum 360°C 5 seconds or less

Stress to Pin

- Applying excessive stress to the input or output pins of the power module may damage internal connections. Avoid applying stress in excess of that shown in right figure.
- Input/output pin are soldered to the PCB internally.
Do not pull or bend a lead powerfully.

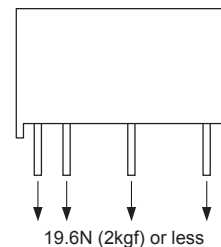

- If it is expected that stress is applied to the input/output pin due to vibration or impact, reduce the stress to the pin by taking such measures as fixing the unit to the PCB by silicone rubber, etc.
- Due to prevent failure, PS should not be pulled after soldering with PCB.

Derating

Derating curve for input voltage

● MGF3/MGFS10

■ MGF3, MGF3, MGF3 and MGF3 has derating by input voltage is required. shown below.

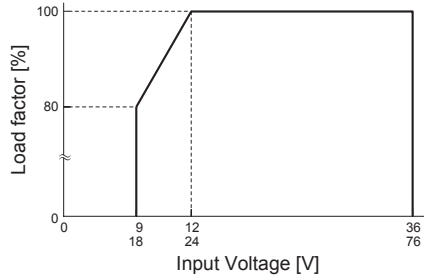

● MGX1R5/MGX6

■ MGX1R5, MGX1R5, MGX6 and MGX6 has derating by input voltage is required. shown below.

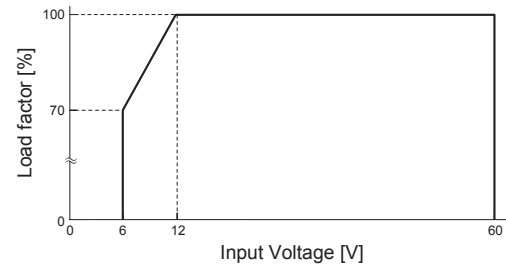

Ambient temperature derating curve

■ It is necessary to note thermal fatigue life by power cycle. Please reduce the temperature fluctuation range as much as possible when the up and down of temperature are frequently generated.

■ In case of forced air, ventilation must keep the temperature of point below the temperatures shown in Instruction Manual 7.

MG

● MGS1R5/MGW1R5 (Rated Input Voltage)

(1) In the case of Convection Cooling (Reference)

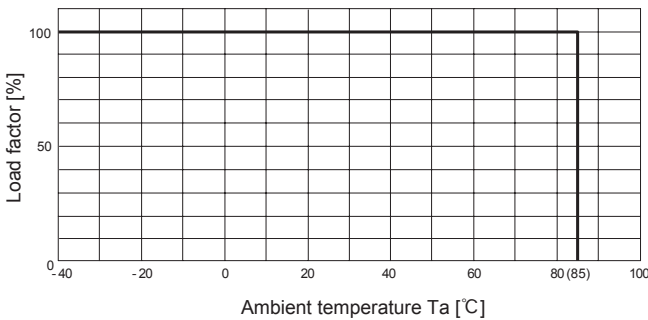

(2) In the case of Forced Air Cooling (1.0m/s) (Reference)

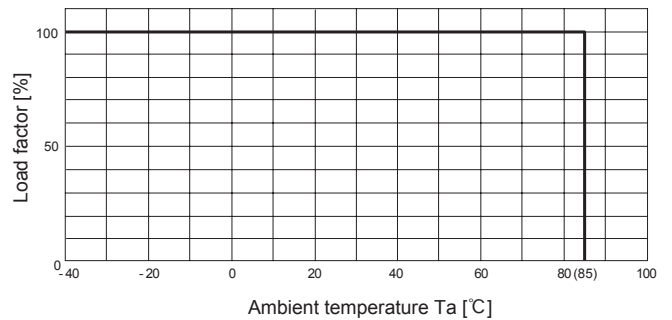

● MGS3/MGW3 (Rated Input Voltage)

(1) In the case of Convection Cooling (Reference)

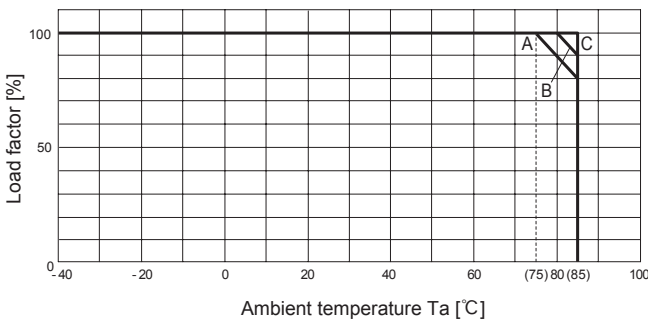

(2) In the case of Forced Air Cooling (1.0m/s) (Reference)

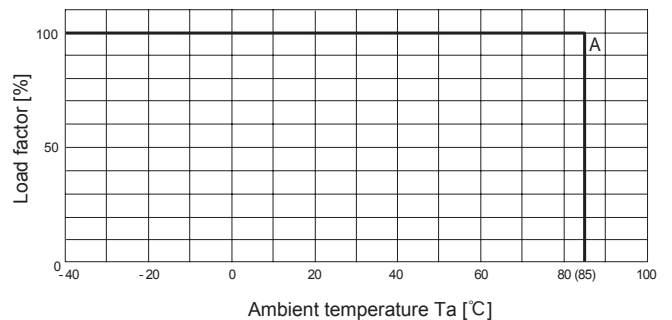

Output Voltage Input Voltage	3.3	5	12	15	±12	±15
5	B	B	C	C	B	B
12	B	C	C	C	B	C
24	B	C	C	C	B	C
48	A	A	C	C	B	C

Output Voltage Input Voltage	3.3	5	12	15	±12	±15
5	A	A	A	A	A	A
12	A	A	A	A	A	A
24	A	A	A	A	A	A
48	A	A	A	A	A	A

Derating

● MGS6/MGW6 (Rated Input Voltage)

■ In the hatched area, the specification of Ripple, Ripple Noise is different from other area.

(1) In the case of Convection Cooling (Reference)

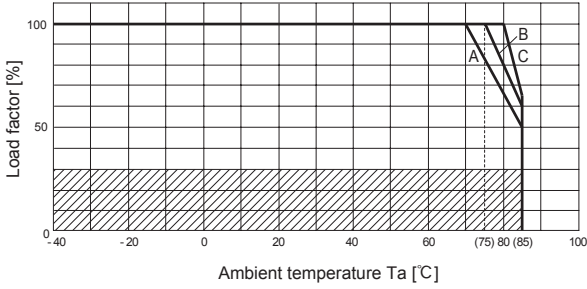

(2) In the case of Forced Air Cooling (1.0m/s) (Reference)

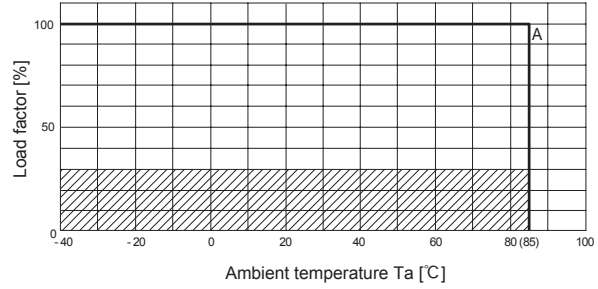

Output Voltage Input Voltage	3.3	5	12	15	±12	±15
5	A	B	B	C	C	C
12	A	B	C	C	C	C
24	A	B	C	C	C	C
48	A	A	C	C	C	C

Output Voltage Input Voltage	3.3	5	12	15	±12	±15
5	A	A	A	A	A	A
12	A	A	A	A	A	A
24	A	A	A	A	A	A
48	A	A	A	A	A	A

MG

● MGS10/MGW10 (Rated Input Voltage)

■ In the hatched area, the specification of Ripple, Ripple Noise is different from other area.

(1) In the case of Convection Cooling (Reference)

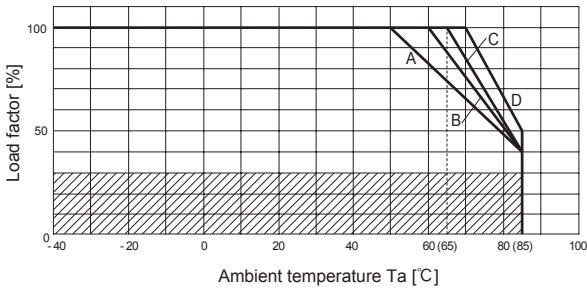

(2) In the case of Forced Air Cooling (1.0m/s) (Reference)

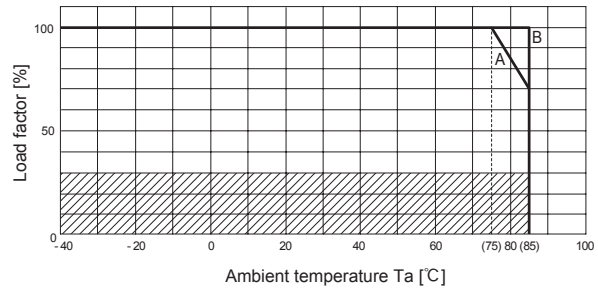

Output Voltage Input Voltage	3.3	5	12	15	±12	±15
5	A	A	A	A	A	A
12	C	C	C	D	B	B
24	B	C	C	D	B	C
48	B	C	C	D	B	C

Output Voltage Input Voltage	3.3	5	12	15	±12	±15
5	A	A	A	A	A	A
12	B	B	B	B	B	B
24	B	B	B	B	B	B
48	B	B	B	B	B	B

● MGFS1R5/MGFW1R5 (Rated Input Voltage)

(1) In the case of Convection Cooling (Reference)

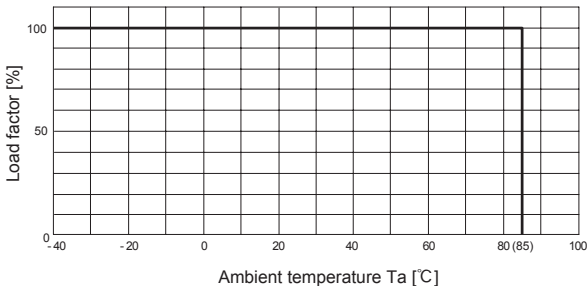

(2) In the case of Forced Air Cooling (1.0m/s) (Reference)

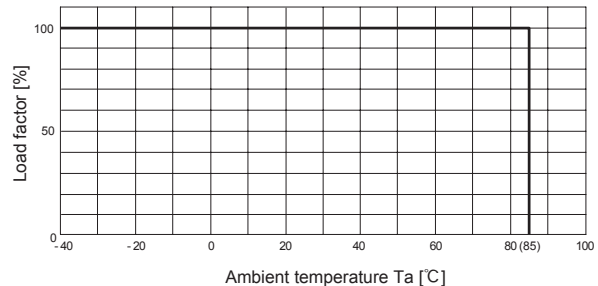

Derating

● MGFS3/MGFW3 (Rated Input Voltage)

(1) In the case of Convection Cooling (Reference)

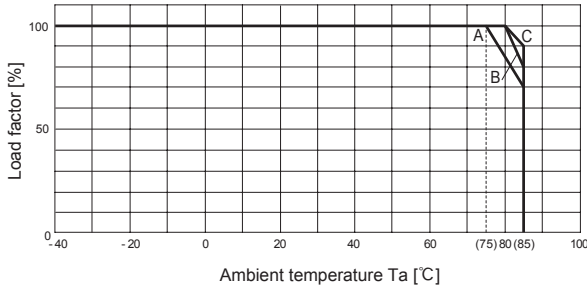

(2) In the case of Forced Air Cooling (1.0m/s) (Reference)

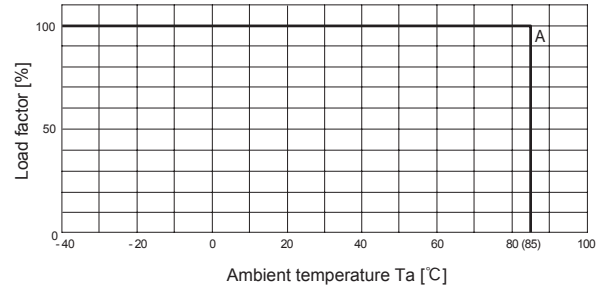

Output Voltage Input Voltage	3.3	5	12	15	±12	±15
12-24	A	A	C	C	C	C
24-48	A	A	B	B	B	B

Output Voltage Input Voltage	3.3	5	12	15	±12	±15
12-24	A	A	A	A	A	A
24-48	A	A	A	A	A	A

● MGFS6/MGFW6 (Rated Input Voltage)

■ In the hatched area, the specification of Ripple, Ripple Noise is different from other area.

(1) In the case of Convection Cooling (Reference)

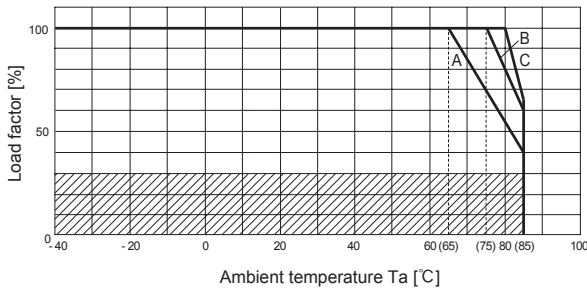

(2) In the case of Forced Air Cooling (1.0m/s) (Reference)

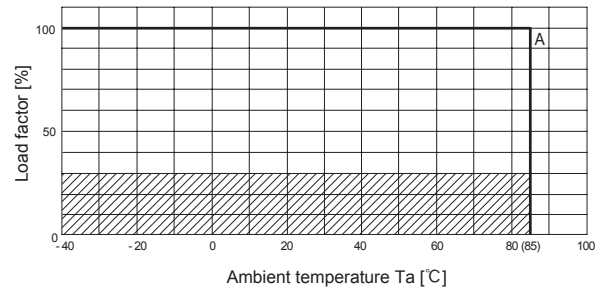

Output Voltage Input Voltage	3.3	5	12	15	±12	±15
12-24	A	A	C	C	C	C
24-48	A	A	C	C	B	B

Output Voltage Input Voltage	3.3	5	12	15	±12	±15
12-24	A	A	A	A	A	A
24-48	A	A	A	A	A	A

● MGFS10/MGFW10 (Rated Input Voltage)

■ In the hatched area, the specification of Ripple, Ripple Noise is different from other area.

(1) In the case of Convection Cooling (Reference)

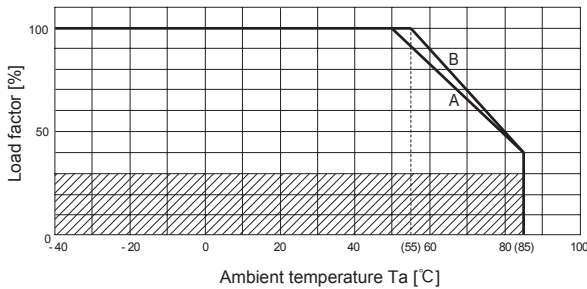

(2) In the case of Forced Air Cooling (1.0m/s) (Reference)

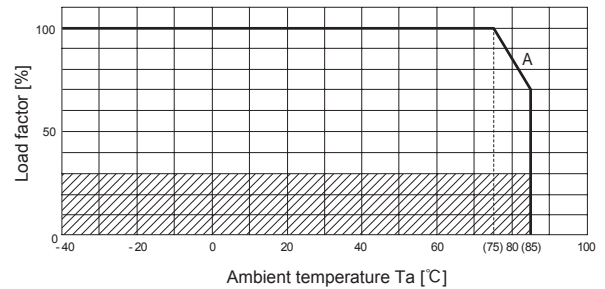

Output Voltage Input Voltage	3.3	5	12	15	±12	±15
12-24	B	B	B	B	A	A
24-48	B	B	B	B	B	B

Output Voltage Input Voltage	3.3	5	12	15	±12	±15
12-24	A	A	A	A	A	A
24-48	A	A	A	A	A	A

Derating

● MGXS1R5/MGXW1R5 (Rated Input Voltage)

(1) In the case of Convection Cooling (Reference)

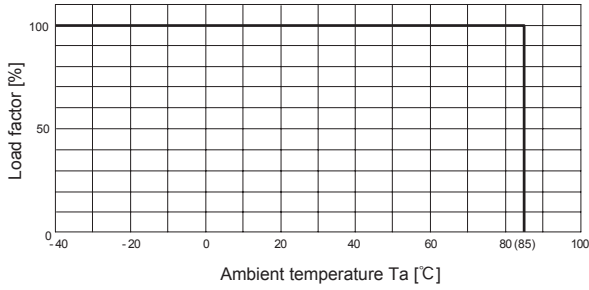

(2) In the case of Forced Air Cooling (1.0m/s) (Reference)

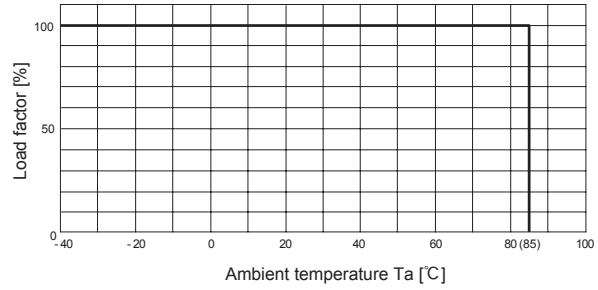

● MGXS6/MGFXW6 (Rated Input Voltage)

■ In the hatched area, the specification of Ripple, Ripple Noise is different from other area.

(1) In the case of Convection Cooling (Reference)

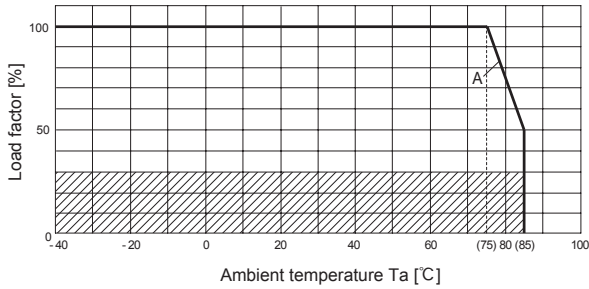

(2) In the case of Forced Air Cooling (1.0m/s) (Reference)

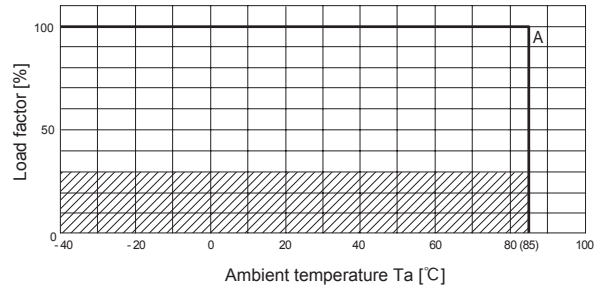

Output Voltage						
Input Voltage	3.3	5	12	15	±12	±15
12-48	A	A	A	A	A	A

Output Voltage						
Input Voltage	3.3	5	12	15	±12	±15
12-48	A	A	A	A	A	A

Instruction Manual

◆ It is necessary to read the "Instruction Manual" and "Before using our product" before you use our product.

Instruction Manual	https://www.cosel.co.jp/redirect/catalog/en/MGS/
Instruction Manual	https://www.cosel.co.jp/redirect/catalog/en/MGW/
Instruction Manual	https://www.cosel.co.jp/redirect/catalog/en/MGFS/
Instruction Manual	https://www.cosel.co.jp/redirect/catalog/en/MGFW/
Instruction Manual	https://www.cosel.co.jp/redirect/catalog/en/MGXS/
Instruction Manual	https://www.cosel.co.jp/redirect/catalog/en/MGXW/
Before using our product	https://en.cosel.co.jp/technical/caution/index.html



Basic Characteristics Data

Model	Circuit method	Switching frequency [kHz] (reference)	Input current [A]	Inrush current protection	PCB/Pattern			Series/Parallel operation availability	
					Material	Single sided	Double sided	Series operation	Parallel operation
MG1R5	Flyback converter	200-1500 *3	*1	-	glass fabric base,epoxy resin		Yes	Yes	*2
MGF1R5	Flyback converter	120-1500 *3	*1	-	glass fabric base,epoxy resin		Yes	Yes	*2
MGX1R5	Flyback converter	60-1000 *3	*1	-	glass fabric base,epoxy resin		Yes	Yes	*2
MG3	Flyback converter	200-1500 *3	*1	-	glass fabric base,epoxy resin		Yes	Yes	*2
MGF3	Flyback converter	120-1500 *3	*1	-	glass fabric base,epoxy resin		Yes	Yes	*2
MG6	Flyback converter	160-1500 *3	*1	-	glass fabric base,epoxy resin		Yes	Yes	*2
MGF6	Flyback converter	120-1500 *3	*1	-	glass fabric base,epoxy resin		Yes	Yes	*2
MGX6	Flyback converter	100-1000 *3	*1	-	glass fabric base,epoxy resin		Yes	Yes	*2
MG10	Flyback converter	160-1500 *3	*1	-	glass fabric base,epoxy resin		Yes	Yes	*2
MGF10	Flyback converter	120-1500 *3	*1	-	glass fabric base,epoxy resin		Yes	Yes	*2

*1 Refer to Specification.

*2 Refer to Instruction Manual.

*3 The value changes depending on input and load.

MGS15

MG S 15 24 05 -□

① ② ③ ④ ⑤ ⑥

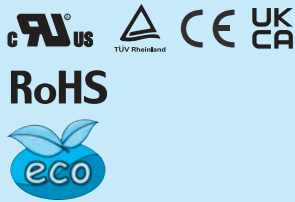

- ① Series name
- ② Single output
- ③ Output wattage
- ④ Input voltage
- ⑤ Output voltage
- ⑥ Optional
- G: Capacitor between Input and Output is removed.
- R: with Remote ON/OFF (Positive logic control)

MODEL	MGS15123R3	MGS151205	MGS151212	MGS151215	MGS15243R3	MGS152405	MGS152412	MGS152415	
MAX OUTPUT WATTAGE[W]	13.2	15	15.6	15	13.2	15	15.6	15	
DC OUTPUT	VOLTAGE[V] *1	3.3	5	12	15	3.3	5	12	15
	CURRENT[A]	4	3	1.3	1	4	3	1.3	1

SPECIFICATIONS

	MODEL	MGS15123R3	MGS151205	MGS151212	MGS151215	MGS15243R3	MGS152405	MGS152412	MGS152415	
INPUT	VOLTAGE[V]	DC9 - 18				DC18 - 36				
	CURRENT[A] *2	1.28typ	1.44typ	1.49typ	1.42typ	0.63typ	0.70typ	0.73typ	0.70typ	
	EFFICIENCY[%] *2	86typ	87typ	87typ	88typ	87typ	89typ	89typ	89typ	
OUTPUT	VOLTAGE[V]	3.3	5	12	15	3.3	5	12	15	
	CURRENT[A]	4	3	1.3	1	4	3	1.3	1	
	LINE REGULATION[mV]	13.2max	20max	48max	60max	13.2max	20max	48max	60max	
	LOAD REGULATION[mV]	13.2max	20max	48max	60max	13.2max	20max	48max	60max	
	RIPPLE[mVp-p] *3	-20 to +60°C	75max	75max	100max	100max	75max	75max	100max	100max
		-40 to -20°C	100max	100max	120max	120max	100max	100max	120max	120max
	RIPPLE NOISE[mVp-p] *3	-20 to +60°C	75max	75max	100max	100max	75max	75max	100max	100max
		-40 to -20°C	150max	150max	150max	150max	150max	150max	150max	150max
	TEMPERATURE REGULATION[mV]	-20 to +60°C	50max	50max	150max	180max	50max	50max	150max	180max
		-40 to +60°C	80max	80max	240max	290max	80max	80max	240max	290max
	DRIFT[mV] *4	20max	20max	48max	60max	20max	20max	48max	60max	
START-UP TIME[ms]	30max (Minimum input, Io=100%)									
OUTPUT VOLTAGE ADJUSTMENT RANGE	Fixed (TRM pin open) Available to adjust ±10% by external variable resistor									
OUTPUT VOLTAGE SETTING[V]*5	3.296 - 3.404	4.975 - 5.137	11.857 - 12.243	14.839 - 15.321	3.296 - 3.404	4.975 - 5.137	11.857 - 12.243	14.839 - 15.321		
PROTECTION CIRCUIT AND OTHERS	OVERCURRENT PROTECTION	Works over 105% of rating and recovers automatically								
	REMOTE ON/OFF	Provided (Negative logic L:ON, H:OFF)								

MODEL	MGS15483R3	MGS154805	MGS154812	MGS154815	
MAX OUTPUT WATTAGE[W]	13.2	15	15.6	15	
DC OUTPUT	VOLTAGE[V] *1	3.3	5	12	15
	CURRENT[A]	4	3	1.3	1

SPECIFICATIONS

	MODEL	MGS15483R3	MGS154805	MGS154812	MGS154815	
INPUT	VOLTAGE[V]	DC36 - 76				
	CURRENT[A] *2	0.32typ	0.35typ	0.36typ	0.35typ	
	EFFICIENCY[%] *2	87typ	89typ	90typ	90typ	
OUTPUT	VOLTAGE[V]	3.3	5	12	15	
	CURRENT[A]	4	3	1.3	1	
	LINE REGULATION[mV]	13.2max	20max	48max	60max	
	LOAD REGULATION[mV]	13.2max	20max	48max	60max	
	RIPPLE[mVp-p] *3	-20 to +60°C	75max	75max	100max	100max
		-40 to -20°C	100max	100max	120max	120max
	RIPPLE NOISE[mVp-p] *3	-20 to +60°C	75max	75max	100max	100max
		-40 to -20°C	150max	150max	150max	150max
	TEMPERATURE REGULATION[mV]	-20 to +60°C	50max	50max	150max	180max
		-40 to +60°C	80max	80max	240max	290max
	DRIFT[mV] *4	20max	20max	48max	60max	
START-UP TIME[ms]	30max (Minimum input, Io=100%)					
OUTPUT VOLTAGE ADJUSTMENT RANGE	Fixed (TRM pin open) ±10% adjustable by external VR					
OUTPUT VOLTAGE SETTING[V]*5	3.296 - 3.404	4.975 - 5.137	11.857 - 12.243	14.839 - 15.321		
PROTECTION CIRCUIT AND OTHERS	OVERCURRENT PROTECTION	Works over 105% of rating and recovers automatically				
	REMOTE ON/OFF	Provided (Negative logic L:ON, H:OFF)				

GENERAL SPECIFICATIONS

ISOLATION	INPUT-OUTPUT	DC1,500V 1minute, Cutoff current = 10mA, DC500V 1,000MΩ min (20±15°C)
	INPUT-CASE	DC1,000V 1minute, Cutoff current = 10mA, DC500V 1,000MΩ min (20±15°C)
	OUTPUT-CASE	DC1,000V 1minute, Cutoff current = 10mA, DC500V 1,000MΩ min (20±15°C)
ENVIRONMENT	OPERATING TEMP., HUMID. AND ALTITUDE	-40 to +85°C, 20 to 95%RH (Non condensing) (Refer to "Derating"), 3,000m (10,000feet) max
	STORAGE TEMP., HUMID. AND ALTITUDE	-40 to +100°C, 20 to 95%RH (Non condensing), 9,000m (30,000feet) max
	VIBRATION	10 - 55Hz, 98.0m/s ² (10G), 3minutes period, 60minutes each along X, Y and Z axis
	IMPACT	490.3m/s ² (50G), 11ms, once each along X, Y and Z axis
SAFETY	AGENCY APPROVALS	UL60950-1, C-UL, EN62368-1
OTHERS	CASE SIZE/WEIGHT	25.4 X 9.9 X 25.4mm [1 X 0.39 X 1 inches] (W X H X D) / 20g max
	COOLING METHOD	Convection/Forced air

- *1 MGW15xx05/MGW15xx12/MGW15xx15 is available as single output, +10V/+24V/+30V
- *2 Rated input 12V, 24V or 48V DC Io=100%
- *3 Ripple and Ripple Noise is measured by using test board with ceramic capacitor 22μF at 50mm from output pins. (20MHz Oscilloscope)
- *4 Drift is the DC output accuracy for eight hours period after a half-hour warm-up at 25°C.
- *5 Rated input voltage (DC12V, DC24V, DC48V), rated output wattage, ambient temperature at 25°C.
- * Parallel operation with other model is not possible.

External view

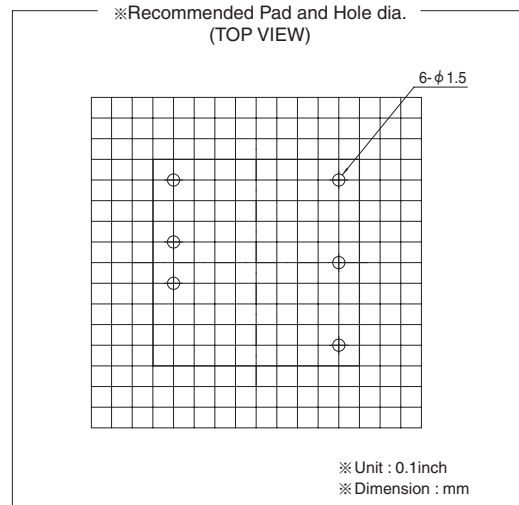
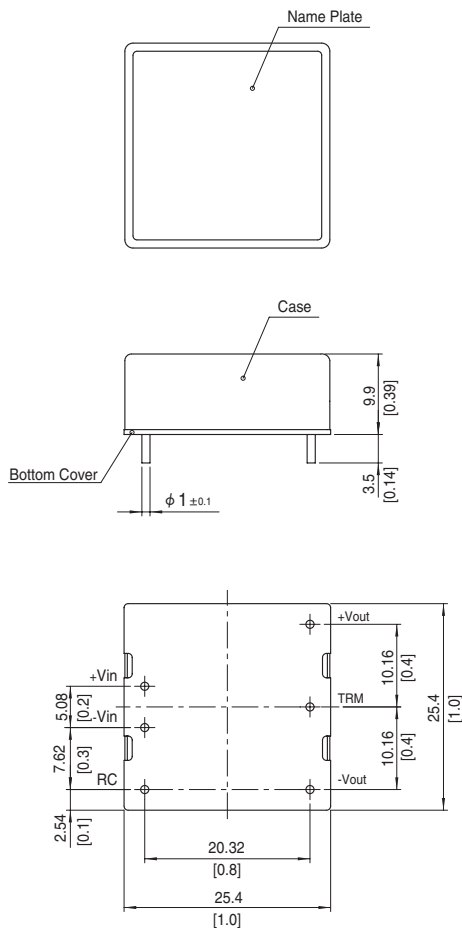

- ※ Tolerance ±0.5 [±0.02]
- ※ Dimensions in mm, []=inches
- ※ Pin terminal material : Copper
- ※ Plating treatment of terminal : Lead free plating
- ※ Case material : Brass
- ※ Plating treatment of case : Nickel plating
- ※ Bottom Cover : FR4 (t=0.6) [t=0.024]
- ※ Please keep enough creepage distance with the pattern on PCB and other components.
- ※ Weight 20g max

MGW15

MG W 15 24 05 - □

① ② ③ ④ ⑤ ⑥

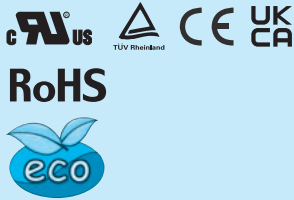

- ① Series name
- ② Dual output
- ③ Output wattage
- ④ Input voltage
- ⑤ Output voltage
- ⑥ Optional
- G: Capacitor between Input and Output is removed.
- R: with Remote ON/OFF (Positive logic control)

MODEL	MGW151205	MGW151212	MGW151215	MGW152405	MGW152412	MGW152415	MGW154805	MGW154812	MGW154815	
MAX OUTPUT WATTAGE[W]	15	15.6	15	15	15.6	15	15	15.6	15	
DC OUTPUT	VOLTAGE[V] *1	±5 or +10	±12 or +24	±15 or +30	±5 or +10	±12 or +24	±15 or +30	±5 or +10	±12 or +24	±15 or +30
	CURRENT[A]	1.5	0.65	0.5	1.5	0.65	0.5	1.5	0.65	0.5

SPECIFICATIONS

	MODEL	MGW151205	MGW151212	MGW151215	MGW152405	MGW152412	MGW152415	MGW154805	MGW154812	MGW154815	
INPUT	VOLTAGE[V]	DC9 - 18			DC18 - 36			DC36 - 76			
	CURRENT[A] *2	1.48typ	1.49typ	1.42typ	0.74typ	0.74typ	0.70typ	0.37typ	0.37typ	0.35typ	
	EFFICIENCY[%] *2	84typ	87typ	88typ	84typ	88typ	89typ	84typ	89typ	89typ	
OUTPUT	VOLTAGE[V]	±5(+10)	±12(+24)	±15(+30)	±5(+10)	±12(+24)	±15(+30)	±5(+10)	±12(+24)	±15(+30)	
	CURRENT[A]	1.5	0.65	0.5	1.5	0.65	0.5	1.5	0.65	0.5	
	LINE REGULATION[mV]	40max	60max	75max	40max	60max	75max	40max	60max	75max	
	LOAD REGULATION[mV]	*3	500max *5	600max	750max	500max *5	600max	750max	500max *5	600max	750max
		*4	250max	480max	600max	250max	480max	600max	250max	480max	600max
	RIPPLE[mVp-p] *6	-20 to +60°C	100max	100max	100max	100max	100max	100max	100max	100max	100max
		-40 to -20°C	120max	120max	120max	120max	120max	120max	120max	120max	120max
	RIPPLE NOISE[mVp-p] *6	-20 to +60°C	100max	100max	100max	100max	100max	100max	100max	100max	100max
		-40 to -20°C	150max	150max	150max	150max	150max	150max	150max	150max	150max
	TEMPERATURE REGULATION[mV]	-20 to +60°C	50max	150max	180max	50max	150max	180max	50max	150max	180max
-40 to +60°C		80max	240max	290max	80max	240max	290max	80max	240max	290max	
DRIFT[mV] *7	50max	50max	60max	50max	50max	60max	50max	50max	60max		
START-UP TIME[ms]	30max (Minimum input, lo=100%)										
OUTPUT VOLTAGE SETTING[V]*8	4.935 - 5.240	11.765 - 12.492	14.602 - 15.505	4.935 - 5.240	11.765 - 12.492	14.602 - 15.505	4.935 - 5.240	11.765 - 12.492	14.602 - 15.505		
PROTECTION CIRCUIT AND OTHERS	OVERCURRENT PROTECTION	Works over 105% of rating and recovers automatically									
	REMOTE ON/OFF	Provided (Negative logic L:ON, H:OFF)									
ISOLATION	INPUT-OUTPUT	DC1,500V 1minute, Cutoff current = 10mA, DC500V 1,000MΩ min (20±15°C)									
	INPUT-CASE	DC1,000V 1minute, Cutoff current = 10mA, DC500V 1,000MΩ min (20±15°C)									
	OUTPUT-CASE	DC1,000V 1minute, Cutoff current = 10mA, DC500V 1,000MΩ min (20±15°C)									
ENVIRONMENT	OPERATING TEMP., HUMID. AND ALTITUDE	-40 to +85°C, 20 to 95%RH (Non condensing) (Refer to "Derating"), 3,000m (10,000feet) max									
	STORAGE TEMP., HUMID. AND ALTITUDE	-40 to +100°C, 20 to 95%RH (Non condensing), 9,000m (30,000feet) max									
	VIBRATION	10 - 55Hz, 98.0m/s ² (10G), 3minutes period, 60minutes each along X, Y and Z axis									
	IMPACT	490.3m/s ² (50G), 11ms, once each along X, Y and Z axis									
SAFETY	AGENCY APPROVALS	UL60950-1, C-UL, EN62368-1									
OTHERS	CASE SIZE/WEIGHT	25.4 × 9.9 × 25.4mm [1 × 0.39 × 1 inches] (W × H × D) / 20g max									
	COOLING METHOD	Convection/Forced air									

*1 Single output +10V, +24V, +30V with no use of COM.
 *2 Rated input 12V, 24V or 48V lo=100%
 *3 An output load is 100%, the other load is 5% to 100%.
 *4 An output load is 100%, the other load is 20% to 100%.
 *5 Refer to the instruction manual 11.
 *6 Ripple and Ripple Noise is measured by using test board with ceramic capacitor 22μF at 50mm from output pins. (20MHz Oscilloscope)
 *7 Drift is the DC output accuracy for eight hours period after a half-hour warm-up at 25°C.
 *8 Rated input voltage (DC12V, DC24V, DC48V), rated output wattage, ambient temperature at 25°C.
 * Parallel operation with other model is not possible.

External view

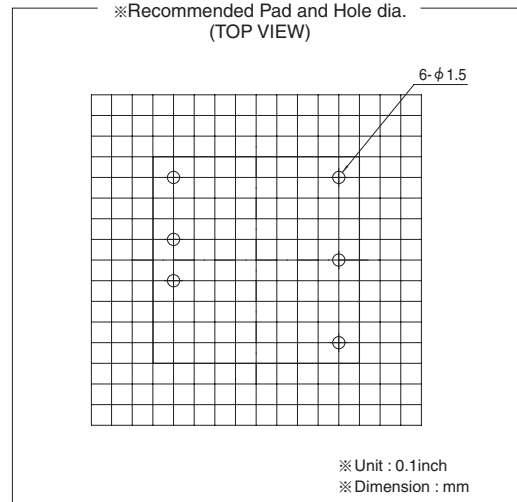
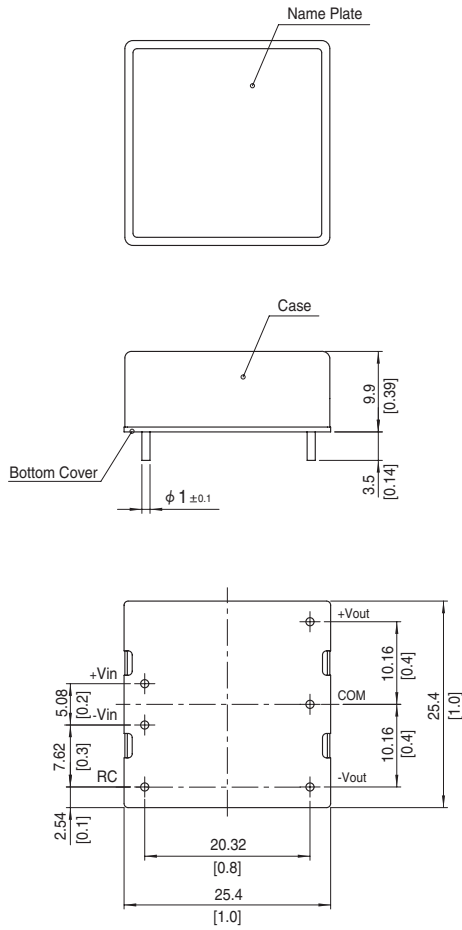

- ※ Tolerance ± 0.5 [± 0.02]
- ※ Dimensions in mm, []=inches
- ※ Pin terminal material : Copper
- ※ Plating treatment of terminal : Lead free plating
- ※ Case material : Brass
- ※ Plating treatment of case : Nickel plating
- ※ Bottom Cover : FR4 (t=0.6) [t=0.024]
- ※ Please keep enough creepage distance with the pattern on PCB and other components.
- ※ Weight 20g max

MGS30

MG S 30 24 05 - □

① ② ③ ④ ⑤ ⑥



- ① Series name
- ② Single output
- ③ Output wattage
- ④ Input voltage
- ⑤ Output voltage
- ⑥ Optional
- G: Capacitor between Input and Output is removed.
- R: with Remote ON/OFF (Positive logic control)

MODEL	MGS30123R3	MGS301205	MGS301212	MGS301215	MGS30243R3	MGS302405	MGS302412	MGS302415
MAX OUTPUT WATTAGE[W]	26.4	30	30	30	26.4	30	30	30
DC OUTPUT	VOLTAGE[V] *1	3.3	5	12	15	3.3	5	12
	CURRENT[A]	8	6	2.5	2	8	6	2.5

SPECIFICATIONS

	MODEL	MGS30123R3	MGS301205	MGS301212	MGS301215	MGS30243R3	MGS302405	MGS302412	MGS302415	
INPUT	VOLTAGE[V]	DC9 - 18				DC18 - 36				
	CURRENT[A] *2	2.45typ	2.75typ	2.78typ	2.78typ	1.21typ	1.36typ	1.36typ	1.36typ	
	EFFICIENCY[%] *2	90typ	91typ	90typ	90typ	91typ	92typ	92typ	92typ	
OUTPUT	VOLTAGE[V]	3.3	5	12	15	3.3	5	12	15	
	CURRENT[A]	8	6	2.5	2	8	6	2.5	2	
	LINE REGULATION[mV]	13.2max	20max	48max	60max	13.2max	20max	48max	60max	
	LOAD REGULATION[mV]	13.2max	20max	48max	60max	13.2max	20max	48max	60max	
	RIPPLE[mVp-p]	-20 to +60°C	75max	75max	100max	100max	75max	75max	100max	100max
		*3 -40 to -20°C	100max	100max	120max	120max	100max	100max	120max	120max
	RIPPLE NOISE[mVp-p]	-20 to +60°C	75max	75max	100max	100max	75max	75max	100max	100max
		*3 -40 to -20°C	150max	150max	150max	150max	150max	150max	150max	150max
	TEMPERATURE REGULATION[mV]	-20 to +60°C	50max	50max	150max	180max	50max	50max	150max	180max
		-40 to +60°C	80max	80max	240max	290max	80max	80max	240max	290max
DRIFT[mV] *4	20max	20max	48max	60max	20max	20max	48max	60max		
START-UP TIME[ms]	30max (Minimum input, Io=100%)									
OUTPUT VOLTAGE ADJUSTMENT RANGE	Fixed (TRM pin open) ±10% adjustable by external VR									
OUTPUT VOLTAGE SETTING[V]*5	3.296 - 3.404	4.975 - 5.137	11.857 - 12.243	14.839 - 15.321	3.296 - 3.404	4.975 - 5.137	11.857 - 12.243	14.839 - 15.321		
PROTECTION CIRCUIT AND OTHERS	OVERCURRENT PROTECTION	Works over 105% of rating and recovers automatically								
	OVERVOLTAGE PROTECTION	Works over 120 to 160% of rating								
	REMOTE ON/OFF	Provided (Negative logic L:ON, H:OFF)								

MODEL	MGS30483R3	MGS304805	MGS304812	MGS304815
MAX OUTPUT WATTAGE[W]	26.4	30	30	30
DC OUTPUT	VOLTAGE[V] *1	3.3	5	12
	CURRENT[A]	8	6	2.5

SPECIFICATIONS

	MODEL	MGS30483R3	MGS304805	MGS304812	MGS304815	
INPUT	VOLTAGE[V]	DC36 - 76				
	CURRENT[A] *2	0.61typ	0.68typ	0.68typ	0.68typ	
	EFFICIENCY[%] *2	91typ	92typ	92typ	92typ	
OUTPUT	VOLTAGE[V]	3.3	5	12	15	
	CURRENT[A]	8	6	2.5	2	
	LINE REGULATION[mV]	13.2max	20max	48max	60max	
	LOAD REGULATION[mV]	13.2max	20max	48max	60max	
	RIPPLE[mVp-p]	-20 to +60°C	75max	75max	100max	100max
		*3 -40 to -20°C	100max	100max	120max	120max
	RIPPLE NOISE[mVp-p]	-20 to +60°C	75max	75max	100max	100max
		*3 -40 to -20°C	150max	150max	150max	150max
	TEMPERATURE REGULATION[mV]	-20 to +60°C	50max	50max	150max	180max
		-40 to +60°C	80max	80max	240max	290max
DRIFT[mV] *4	20max	20max	48max	60max		
START-UP TIME[ms]	30max (Minimum input, Io=100%)					
OUTPUT VOLTAGE ADJUSTMENT RANGE	Fixed (TRM pin open) ±10% adjustable by external VR					
OUTPUT VOLTAGE SETTING[V]*5	3.296 - 3.404	4.975 - 5.137	11.857 - 12.243	14.839 - 15.321		
PROTECTION CIRCUIT AND OTHERS	OVERCURRENT PROTECTION	Works over 105% of rating and recovers automatically				
	OVERVOLTAGE PROTECTION	Works over 120 to 160% of rating				
	REMOTE ON/OFF	Provided (Negative logic L:ON, H:OFF)				

GENERAL SPECIFICATIONS

ISOLATION	INPUT-OUTPUT	DC1,500V 1minute, Cutoff current = 10mA, DC500V 1,000MΩ min (20±15°C)
	INPUT-CASE	DC1,000V 1minute, Cutoff current = 10mA, DC500V 1,000MΩ min (20±15°C)
	OUTPUT-CASE	DC1,000V 1minute, Cutoff current = 10mA, DC500V 1,000MΩ min (20±15°C)
ENVIRONMENT	OPERATING TEMP., HUMID. AND ALTITUDE	-40 to +85°C, 20 to 95%RH (Non condensing) (Refer to "Derating"), 3,000m (10,000feet) max
	STORAGE TEMP., HUMID. AND ALTITUDE	-40 to +100°C, 20 to 95%RH (Non condensing), 9,000m (30,000feet) max
	VIBRATION	10 - 55Hz, 98.0m/s ² (10G), 3minutes period, 60minutes each along X, Y and Z axis
	IMPACT	490.3m/s ² (50G), 11ms, once each along X, Y and Z axis
SAFETY	AGENCY APPROVALS	UL60950-1, C-UL, EN62368-1
OTHERS	CASE SIZE/WEIGHT	25.4 X 9.9 X 50.8mm [1 X 0.39 X 2 inches] (W X H X D) / 40g max
	COOLING METHOD	Convection/Forced air

- *1 MGW30xx05/MGW30xx12/MGW30xx15 is available as single output, +10V/+24V/+30V
- *2 Rated input 12V, 24V or 48V DC I_o=100%
- *3 Ripple and Ripple Noise is measured by using test board with ceramic capacitor 22μF at 50mm from output pins. (20MHz Oscilloscope)
- *4 Drift is the DC output accuracy for eight hours period after a half-hour warm-up at 25°C.
- *5 Rated input voltage (DC12V, DC24V, DC48V), rated output wattage, ambient temperature at 25°C.
- * Parallel operation with other model is not possible.

External view

MG

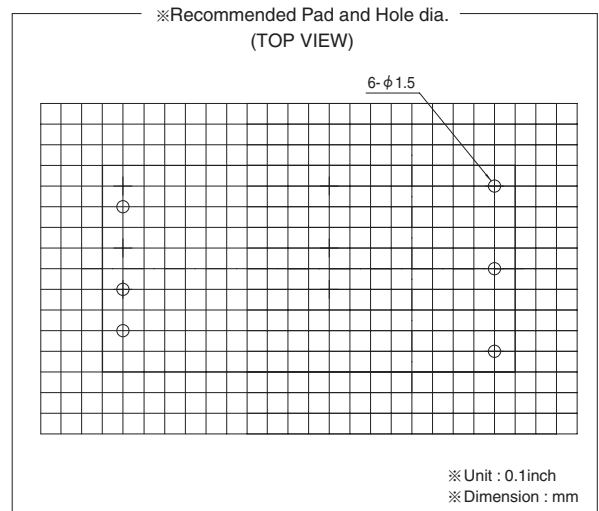
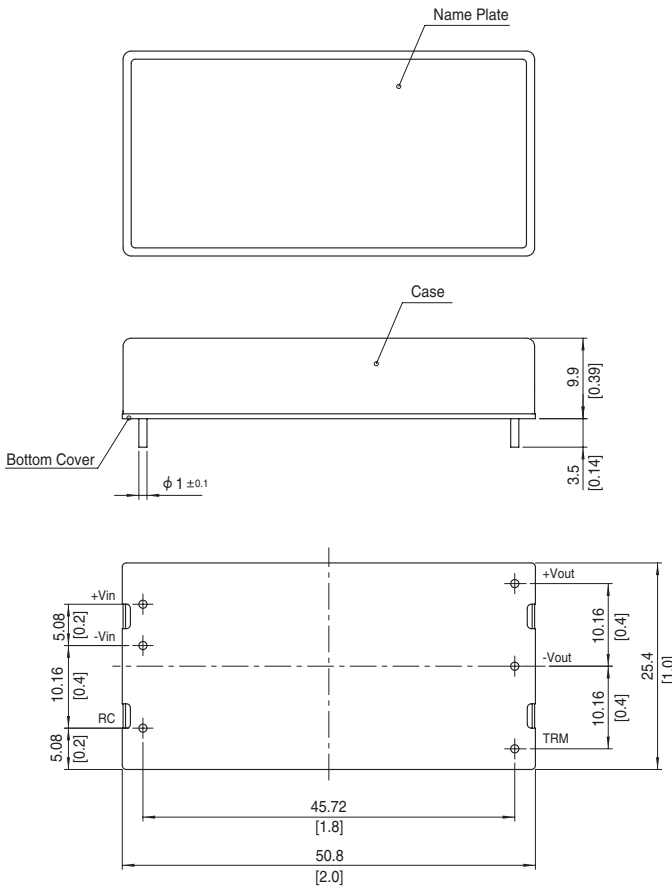

- ※ Tolerance ±0.5 [±0.02]
- ※ Dimensions in mm, []=inches
- ※ Pin terminal material : Copper
- ※ Plating treatment of terminal : Lead free plating
- ※ Case material : Brass
- ※ Plating treatment of case : Nickel plating
- ※ Bottom Cover : FR4 (t=0.6) [t=0.024]
- ※ Please keep enough creepage distance with the pattern on PCB and other components.
- ※ Weight 40g max

MGW30

MG W 30 24 05 - □

① ② ③ ④ ⑤ ⑥



RoHS



- ① Series name
- ② Dual output
- ③ Output wattage
- ④ Input voltage
- ⑤ Output voltage
- ⑥ Optional
- G: Capacitor between Input and Output is removed.
- R: with Remote ON/OFF (Positive logic control)

MG

MODEL	MGW301205	MGW301212	MGW301215	MGW302405	MGW302412	MGW302415	MGW304805	MGW304812	MGW304815	
MAX OUTPUT WATTAGE[W]	25	30	30	25	30	30	25	30	30	
DC OUTPUT	VOLTAGE[V] *1	±5 or +10	±12 or +24	±15 or +30	±5 or +10	±12 or +24	±15 or +30	±5 or +10	±12 or +24	±15 or +30
	CURRENT[A]	2.5	1.25	1	2.5	1.25	1	2.5	1.25	1

SPECIFICATIONS

	MODEL	MGW301205	MGW301212	MGW301215	MGW302405	MGW302412	MGW302415	MGW304805	MGW304812	MGW304815	
INPUT	VOLTAGE[V]	DC9 - 18			DC18 - 36			DC36 - 76			
	CURRENT[A] *2	2.42typ	2.78typ	2.78typ	1.20typ	1.38typ	1.38typ	0.60typ	0.70typ	0.70typ	
	EFFICIENCY[%] *2	86typ	90typ	90typ	87typ	91typ	91typ	87typ	90typ	90typ	
OUTPUT	VOLTAGE[V]	±5(+10)	±12(+24)	±15(+30)	±5(+10)	±12(+24)	±15(+30)	±5(+10)	±12(+24)	±15(+30)	
	CURRENT[A]	2.5	1.25	1	2.5	1.25	1	2.5	1.25	1	
	LINE REGULATION[mV]	40max	60max	75max	40max	60max	75max	40max	60max	75max	
	LOAD REGULATION[mV]	*3	500max *5	600max	750max	500max *5	600max	750max	500max *5	600max	750max
		*4	250max	480max	600max	250max	480max	600max	250max	480max	600max
	RIPPLE[mVp-p] *6	-20 to +60°C	100max	100max	100max	100max	100max	100max	100max	100max	100max
		-40 to -20°C	120max	120max	120max	120max	120max	120max	120max	120max	120max
	RIPPLE NOISE[mVp-p] *6	-20 to +60°C	100max	100max	100max	100max	100max	100max	100max	100max	100max
		-40 to -20°C	150max	150max	150max	150max	150max	150max	150max	150max	150max
	TEMPERATURE REGULATION[mV]	-20 to +60°C	50max	150max	180max	50max	150max	180max	50max	150max	180max
-40 to +60°C		80max	240max	290max	80max	240max	290max	80max	240max	290max	
DRIFT[mV] *7	50max	50max	60max	50max	50max	60max	50max	50max	60max		
START-UP TIME[ms]	30max (Minimum input, Io=100%)										
OUTPUT VOLTAGE SETTING[V]*8	4.935 - 5.240	11.765 - 12.492	14.602 - 15.505	4.935 - 5.240	11.765 - 12.492	14.602 - 15.505	4.935 - 5.240	11.765 - 12.492	14.602 - 15.505		
PROTECTION CIRCUIT AND OTHERS	OVERCURRENT PROTECTION	Works over 105% of rating and recovers automatically									
	OVERVOLTAGE PROTECTION	Works over 120 to 160% of rating (Total of +V and -V)									
	REMOTE ON/OFF	Provided (Negative logic L:ON, H:OFF)									
ISOLATION	INPUT-OUTPUT	DC1,500V 1minute, Cutoff current = 10mA, DC500V 1,000MΩ min (20±15°C)									
	INPUT-CASE	DC1,000V 1minute, Cutoff current = 10mA, DC500V 1,000MΩ min (20±15°C)									
	OUTPUT-CASE	DC1,000V 1minute, Cutoff current = 10mA, DC500V 1,000MΩ min (20±15°C)									
ENVIRONMENT	OPERATING TEMP., HUMID. AND ALTITUDE	-40 to +85°C, 20 to 95%RH (Non condensing) (Refer to "Derating"), 3,000m (10,000feet) max									
	STORAGE TEMP., HUMID. AND ALTITUDE	-40 to +100°C, 20 to 95%RH (Non condensing), 9,000m (30,000feet) max									
	VIBRATION	10 - 55Hz, 98.0m/s ² (10G), 3minutes period, 60minutes each along X, Y and Z axis									
	IMPACT	490.3m/s ² (50G), 11ms, once each along X, Y and Z axis									
SAFETY	AGENCY APPROVALS	UL60950-1, C-UL, EN62368-1									
OTHERS	CASE SIZE/WEIGHT	25.4 X 9.9 X 50.8mm [1 X 0.39 X 2 inches] (W X H X D) / 40g max									
	COOLING METHOD	Convection/Forced air									

*1 Single output +10V, +24V, +30V with no use of COM.

*2 Rated input 12V, 24V or 48V DC Io=100%

*3 Symmetrical loading from 5% to 100%.

*4 Symmetrical loading from 20% to 100%.

*5 Refer to the instruction manual 11.

*6 Ripple and Ripple Noise is measured by using test board with ceramic capacitor 22μF at 50mm from output pins. (20MHz Oscilloscope)

*7 Drift is the DC output accuracy for eight hours period after a half-hour warm-up at 25°C.

*8 Rated input voltage (DC12V, DC24V, DC48V), rated output wattage, ambient temperature at 25°C.

* Parallel operation with other model is not possible.

External view

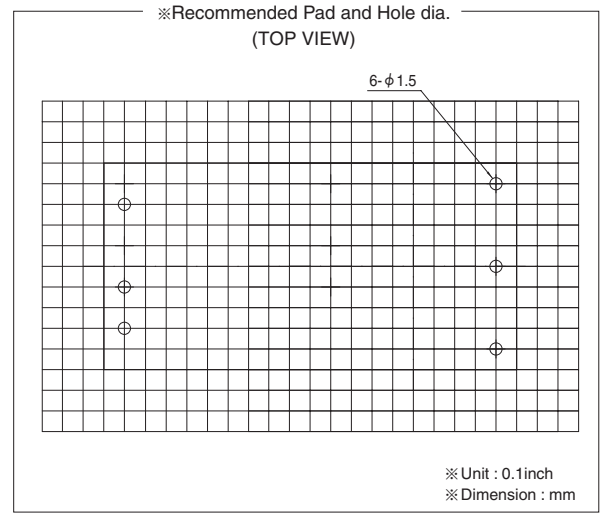
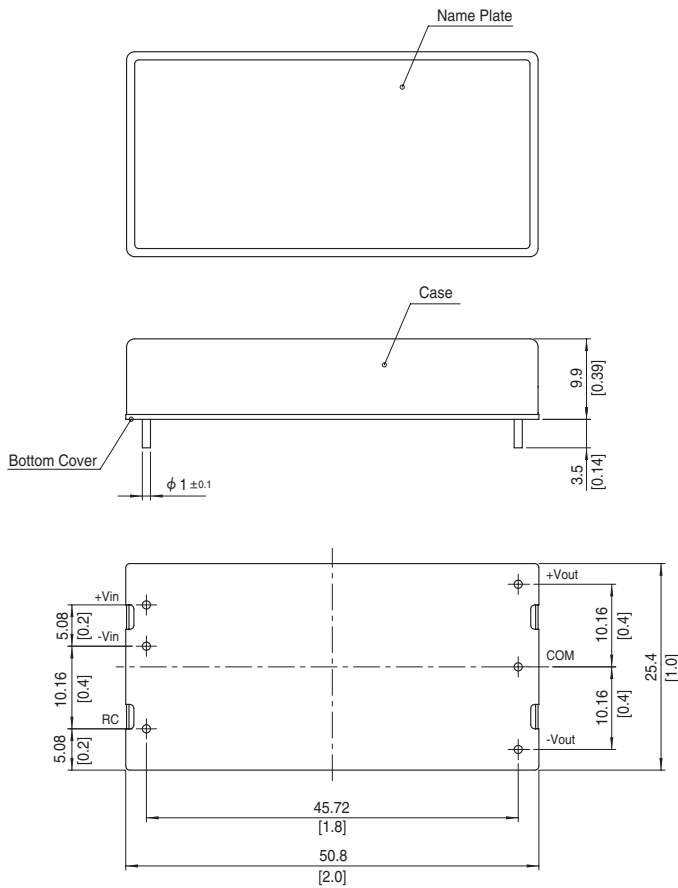

- ※ Tolerance ± 0.5 [± 0.02]
- ※ Dimensions in mm, []=inches
- ※ Pin terminal material : Copper
- ※ Plating treatment of terminal : Lead free plating
- ※ Case material : Brass
- ※ Plating treatment of case : Nickel plating
- ※ Bottom Cover : FR4 (t=0.6) [t=0.024]
- ※ Please keep enough creepage distance with the pattern on PCB and other components.
- ※ Weight 40g max

MG

MGFS15

MGF S 15 24 05 -□

① ② ③ ④ ⑤ ⑥

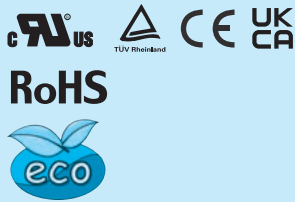

- ① Series name
- ② Single output
- ③ Output wattage
- ④ Input voltage
- ⑤ Output voltage
- ⑥ Optional
- G: Capacitor between Input and Output is removed.
- R: with Remote ON/OFF (Positive logic control)

MODEL	MGFS15243R3	MGFS152405	MGFS152412	MGFS152415
MAX OUTPUT WATTAGE[W]	13.2	15	15.6	15
DC OUTPUT	VOLTAGE[V] *1	3.3	5	12
	CURRENT[A]	4	3	1.3

SPECIFICATIONS

	MODEL	MGFS15243R3	MGFS152405	MGFS152412	MGFS152415	
INPUT	VOLTAGE[V]	DC9 - 36				
	CURRENT[A] *2	0.63typ	0.71typ	0.73typ	0.70typ	
	EFFICIENCY[%] *2	87typ	88typ	89typ	89typ	
OUTPUT	VOLTAGE[V]	3.3	5	12	15	
	CURRENT[A]	4	3	1.3	1	
	LINE REGULATION[mV]	13.2max	20max	48max	60max	
	LOAD REGULATION[mV]	13.2max	20max	48max	60max	
	RIPPLE[mVp-p]	-20 to +60°C	75max	75max	100max	100max
		*3 -40 to -20°C	100max	100max	120max	120max
	RIPPLE NOISE[mVp-p]	-20 to +60°C	75max	75max	100max	100max
		*3 -40 to -20°C	150max	150max	150max	150max
	TEMPERATURE REGULATION[mV]	-20 to +60°C	50max	50max	150max	180max
		-40 to +60°C	80max	80max	240max	290max
	DRIFT[mV] *4	20max	20max	48max	60max	
START-UP TIME[ms]	30max (Minimum input, lo=100%)					
OUTPUT VOLTAGE ADJUSTMENT RANGE	Fixed (TRM pin open) ±10% adjustable by external VR					
OUTPUT VOLTAGE SETTING[V]*5	3.296 - 3.404	4.975 - 5.137	11.857 - 12.243	14.839 - 15.321		
PROTECTION CIRCUIT AND OTHERS	OVERCURRENT PROTECTION	Works over 105% of rating and recovers automatically				
	REMOTE ON/OFF	Provided (Negative logic L:ON, H:OFF)				

MODEL	MGFS15483R3	MGFS154805	MGFS154812	MGFS154815
MAX OUTPUT WATTAGE[W]	13.2	15	15.6	15
DC OUTPUT	VOLTAGE[V] *1	3.3	5	12
	CURRENT[A]	4	3	1.3

SPECIFICATIONS

	MODEL	MGFS15483R3	MGFS154805	MGFS154812	MGFS154815	
INPUT	VOLTAGE[V]	DC18 - 76				
	CURRENT[A] *2	0.32typ	0.36typ	0.37typ	0.35typ	
	EFFICIENCY[%] *2	87typ	88typ	88typ	89typ	
OUTPUT	VOLTAGE[V]	3.3	5	12	15	
	CURRENT[A]	4	3	1.3	1	
	LINE REGULATION[mV]	13.2max	20max	48max	60max	
	LOAD REGULATION[mV]	13.2max	20max	48max	60max	
	RIPPLE[mVp-p]	-20 to +60°C	75max	75max	100max	100max
		*3 -40 to -20°C	100max	100max	120max	120max
	RIPPLE NOISE[mVp-p]	-20 to +60°C	75max	75max	100max	100max
		*3 -40 to -20°C	150max	150max	150max	150max
	TEMPERATURE REGULATION[mV]	-20 to +60°C	50max	50max	150max	180max
		-40 to +60°C	80max	80max	240max	290max
	DRIFT[mV] *4	20max	20max	48max	60max	
START-UP TIME[ms]	30max (Minimum input, lo=100%)					
OUTPUT VOLTAGE ADJUSTMENT RANGE	Fixed (TRM pin open) ±10% adjustable by external VR					
OUTPUT VOLTAGE SETTING[V]*5	3.296 - 3.404	4.975 - 5.137	11.857 - 12.243	14.839 - 15.321		
PROTECTION CIRCUIT AND OTHERS	OVERCURRENT PROTECTION	Works over 105% of rating and recovers automatically				
	REMOTE ON/OFF	Provided (Negative logic L:ON, H:OFF)				

GENERAL SPECIFICATIONS

ISOLATION	INPUT-OUTPUT	DC1,500V 1minute, Cutoff current = 10mA, DC500V 1,000MΩ min (20±15°C)
	INPUT-CASE	DC1,000V 1minute, Cutoff current = 10mA, DC500V 1,000MΩ min (20±15°C)
	OUTPUT-CASE	DC1,000V 1minute, Cutoff current = 10mA, DC500V 1,000MΩ min (20±15°C)
ENVIRONMENT	OPERATING TEMP., HUMID. AND ALTITUDE	-40 to +85°C, 20 to 95%RH (Non condensing) (Refer to "Derating"), 3,000m (10,000feet) max
	STORAGE TEMP., HUMID. AND ALTITUDE	-40 to +100°C, 20 to 95%RH (Non condensing), 9,000m (30,000feet) max
	VIBRATION	10 - 55Hz, 98.0m/s ² (10G), 3minutes period, 60minutes each along X, Y and Z axis
	IMPACT	490.3m/s ² (50G), 11ms, once each along X, Y and Z axis
SAFETY	AGENCY APPROVALS	UL60950-1, C-UL, EN62368-1
OTHERS	CASE SIZE/WEIGHT	25.4 X 9.9 X 25.4mm [1 X 0.39 X 1 inches] (W X H X D) / 20g max
	COOLING METHOD	Convection/Forced air

- *1 MGFW15xx05/MGFW15xx12/MGFW15xx15 is available as single output, +10V/+24V/+30V
- *2 Rated input 12V, 24V or 48V DC Io=100%
- *3 Ripple and Ripple Noise is measured by using test board with ceramic capacitor 22μF at 50mm from output pins. (20MHz Oscilloscope)
- *4 Drift is the DC output accuracy for eight hours period after a half-hour warm-up at 25°C.
- *5 Rated input voltage (DC24V, DC48V), rated output wattage, ambient temperature at 25°C.
- * Parallel operation with other model is not possible.

External view

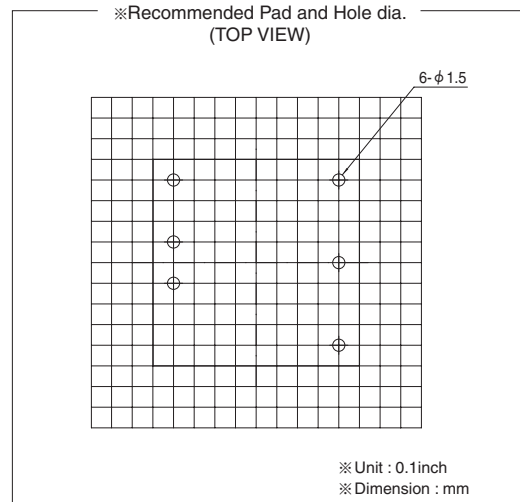
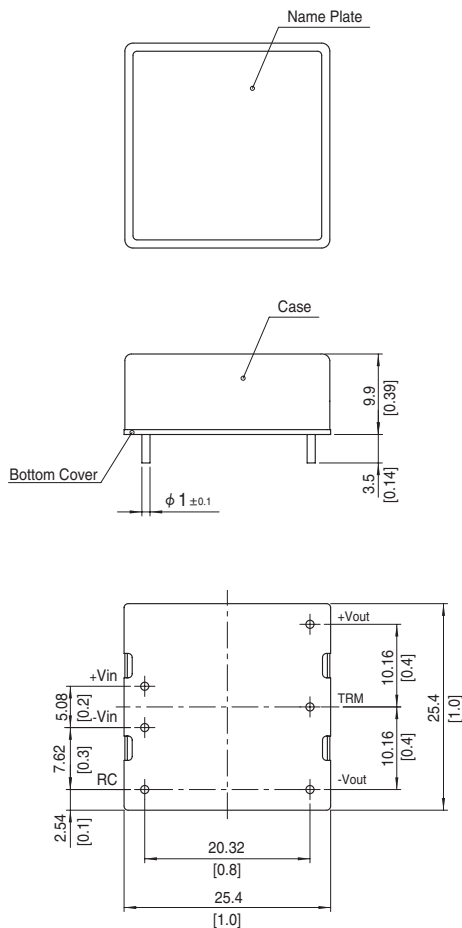

- ※ Tolerance ±0.5 [±0.02]
- ※ Dimensions in mm, []=inches
- ※ Pin terminal material : Copper
- ※ Plating treatment of terminal : Lead free plating
- ※ Case material : Brass
- ※ Plating treatment of case : Nickel plating
- ※ Bottom Cover : FR4 (t=0.6) [t=0.024]
- ※ Please keep enough creepage distance with the pattern on PCB and other components.
- ※ Weight 20g max

MGFW15

MGF W 15 24 05 -□

① ② ③ ④ ⑤ ⑥

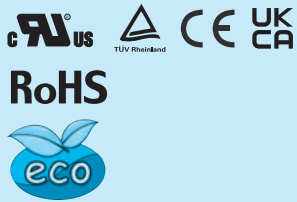

- ① Series name
 - ② Dual output
 - ③ Output wattage
 - ④ Input voltage
 - ⑤ Output voltage
 - ⑥ Optional
- G: Capacitor between Input and Output is removed.
R: with Remote ON/OFF (Positive logic control)

MODEL	MGFW152405	MGFW152412	MGFW152415	MGFW154805	MGFW154812	MGFW154815
MAX OUTPUT WATTAGE[W]	15	15.6	15	15	15.6	15
DC OUTPUT	VOLTAGE[V] *1	±5 or +10	±12 or +24	±15 or +30	±5 or +10	±12 or +24
	CURRENT[A]	1.5	0.65	0.5	1.5	0.65

SPECIFICATIONS

	MODEL	MGFW152405	MGFW152412	MGFW152415	MGFW154805	MGFW154812	MGFW154815	
INPUT	VOLTAGE[V]	DC9 - 36			DC18 - 76			
	CURRENT[A] *2	0.74typ	0.74typ	0.70typ	0.37typ	0.37typ	0.36typ	
	EFFICIENCY[%] *2	84typ	88typ	89typ	84typ	87typ	88typ	
OUTPUT	VOLTAGE[V]	±5(+10)	±12(+24)	±15(+30)	±5(+10)	±12(+24)	±15(+30)	
	CURRENT[A]	1.5	0.65	0.5	1.5	0.65	0.5	
	LINE REGULATION[mV]	40max	60max	75max	40max	60max	75max	
	LOAD REGULATION[mV]	*3	500max *5	600max	750max	500max *5	600max	750max
		*4	250max	480max	600max	250max	480max	600max
	RIPPLE[mVp-p] *6	-20 to +60°C	100max	100max	100max	100max	100max	100max
		-40 to -20°C	120max	120max	120max	120max	120max	120max
	RIPPLE NOISE[mVp-p] *6	-20 to +60°C	100max	100max	100max	100max	100max	100max
		-40 to -20°C	150max	150max	150max	150max	150max	150max
	TEMPERATURE REGULATION[mV]	-20 to +60°C	50max	150max	180max	50max	150max	180max
		-40 to +60°C	80max	240max	290max	80max	240max	290max
DRIFT[mV] *7	50max	50max	60max	50max	50max	60max		
START-UP TIME[ms]	30max (Minimum input, Io=100%)							
OUTPUT VOLTAGE SETTING[V]*8	4.935 - 5.240	11.765 - 12.492	14.602 - 15.505	4.935 - 5.240	11.765 - 12.492	14.602 - 15.505		
PROTECTION CIRCUIT AND OTHERS	OVERCURRENT PROTECTION	Works over 105% of rating and recovers automatically						
	REMOTE ON/OFF	Provided (Negative logic L:ON, H:OFF)						
ISOLATION	INPUT-OUTPUT	DC1,500V 1minute, Cutoff current = 10mA, DC500V 1,000MΩ min (20±15°C)						
	INPUT-CASE	DC1,000V 1minute, Cutoff current = 10mA, DC500V 1,000MΩ min (20±15°C)						
	OUTPUT-CASE	DC1,000V 1minute, Cutoff current = 10mA, DC500V 1,000MΩ min (20±15°C)						
ENVIRONMENT	OPERATING TEMP., HUMID. AND ALTITUDE	-40 to +85°C, 20 to 95%RH (Non condensing) (Refer to "Derating"), 3,000m (10,000feet) max						
	STORAGE TEMP., HUMID. AND ALTITUDE	-40 to +100°C, 20 to 95%RH (Non condensing), 9,000m (30,000feet) max						
	VIBRATION	10 - 55Hz, 98.0m/s ² (10G), 3minutes period, 60minutes each along X, Y and Z axis						
	IMPACT	490.3m/s ² (50G), 11ms, once each along X, Y and Z axis						
SAFETY	AGENCY APPROVALS	UL60950-1, C-UL, EN62368-1						
OTHERS	CASE SIZE/WEIGHT	25.4×9.9×25.4mm [1×0.39×1 inches] (W×H×D) / 20g max						
	COOLING METHOD	Convection/Forced air						

*1 Single output +10V, +24V, +30V with no use of COM.

*2 Rated input 12V, 24V or 48V DC Io=100%

*3 Symmetrical loading from 5% to 100%.

*4 Symmetrical loading from 20% to 100%.

*5 Refer to the instruction manual 11.

*6 Ripple and Ripple Noise is measured by using test board with ceramic capacitor 22μF at 50mm from output pins. (20MHz Oscilloscope)

*7 Drift is the DC output accuracy for eight hours period after a half-hour warm-up at 25°C.

*8 Rated input voltage (DC24V, DC48V), rated output wattage, ambient temperature at 25°C.

* Parallel operation with other model is not possible.

External view

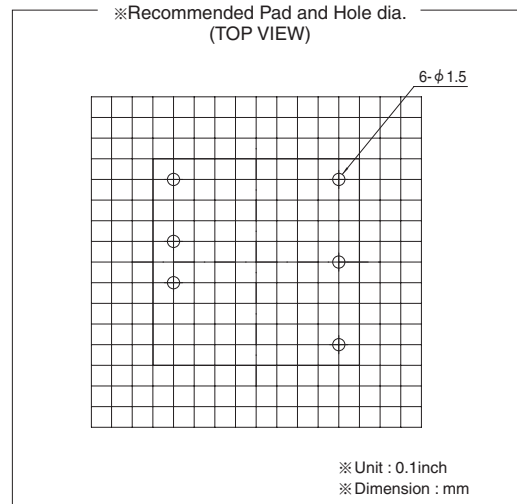
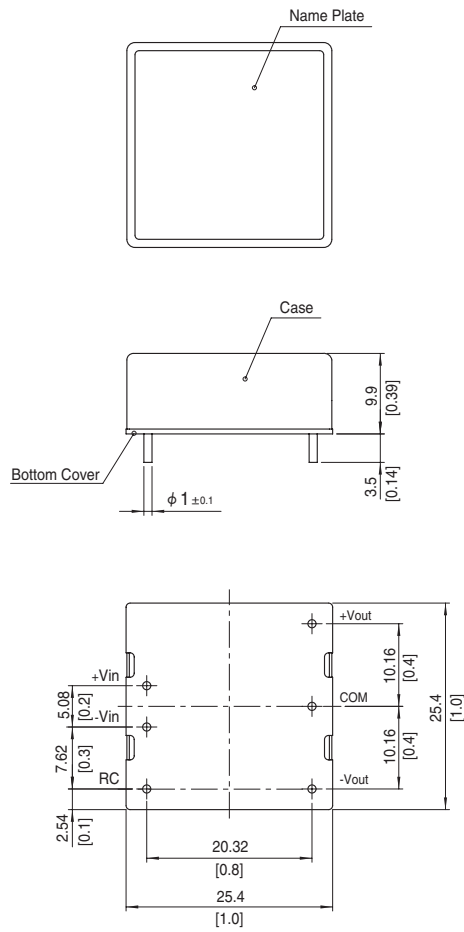

- ※ Tolerance ± 0.5 [± 0.02]
- ※ Dimensions in mm, []=inches
- ※ Pin terminal material : Copper
- ※ Plating treatment of terminal : Lead free plating
- ※ Case material : Brass
- ※ Plating treatment of case : Nickel plating
- ※ Bottom Cover : FR4 (t=0.6) [t=0.024]
- ※ Please keep enough creepage distance with the pattern on PCB and other components.
- ※ Weight 20g max

MGFS30

MGF S 30 24 05 -□

① ② ③ ④ ⑤ ⑥

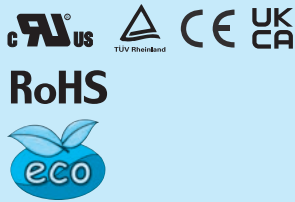

- ① Series name
- ② Single output
- ③ Output wattage
- ④ Input voltage
- ⑤ Output voltage
- ⑥ Optional
- G: Capacitor between Input and Output is removed.
- R: with Remote ON/OFF (Positive logic control)

MODEL	MGFS30243R3	MGFS302405	MGFS302412	MGFS302415
MAX OUTPUT WATTAGE[W]	24.75	30	30	30
DC OUTPUT	VOLTAGE[V] *1	3.3	5	12
	CURRENT[A]	7.5	6	2.5

SPECIFICATIONS

	MODEL	MGFS30243R3	MGFS302405	MGFS302412	MGFS302415	
INPUT	VOLTAGE[V]	DC9 - 36				
	CURRENT[A] *2	1.16typ	1.39typ	1.40typ	1.40typ	
	EFFICIENCY[%] *2	89typ	90typ	89typ	89typ	
OUTPUT	VOLTAGE[V]	3.3	5	12	15	
	CURRENT[A]	7.5	6	2.5	2	
	LINE REGULATION[mV]	13.2max	20max	48max	60max	
	LOAD REGULATION[mV]	13.2max	20max	48max	60max	
	RIPPLE[mVp-p]	-20 to +60°C	75max	75max	100max	100max
		*3 -40 to -20°C	100max	100max	120max	120max
	RIPPLE NOISE[mVp-p]	-20 to +60°C	75max	75max	100max	100max
		*3 -40 to -20°C	150max	150max	150max	150max
	TEMPERATURE REGULATION[mV]	-20 to +60°C	50max	50max	150max	180max
		-40 to +60°C	80max	80max	240max	290max
	DRIFT[mV] *4	20max	20max	48max	60max	
START-UP TIME[ms]	30max (Minimum input, I _o =100%)					
OUTPUT VOLTAGE ADJUSTMENT RANGE	Fixed (TRM pin open) ±10% adjustable by external VR					
OUTPUT VOLTAGE SETTING[V]*5	3.296 - 3.404	4.975 - 5.137	11.857 - 12.243	14.839 - 15.321		
PROTECTION CIRCUIT AND OTHERS	OVERCURRENT PROTECTION	Works over 105% of rating and recovers automatically				
	OVERVOLTAGE PROTECTION	Works over 120 to 160% of rating				
	REMOTE ON/OFF	Provided (Negative logic L:ON, H:OFF)				

MODEL	MGFS30483R3	MGFS304805	MGFS304812	MGFS304815
MAX OUTPUT WATTAGE[W]	24.75	30	30	30
DC OUTPUT	VOLTAGE[V] *1	3.3	5	12
	CURRENT[A]	7.5	6	2.5

SPECIFICATIONS

	MODEL	MGFS30483R3	MGFS304805	MGFS304812	MGFS304815	
INPUT	VOLTAGE[V]	DC18 - 76				
	CURRENT[A] *2	0.58typ	0.70typ	0.70typ	0.70typ	
	EFFICIENCY[%] *2	89typ	90typ	89typ	89typ	
OUTPUT	VOLTAGE[V]	3.3	5	12	15	
	CURRENT[A]	7.5	6	2.5	2	
	LINE REGULATION[mV]	13.2max	20max	48max	60max	
	LOAD REGULATION[mV]	13.2max	20max	48max	60max	
	RIPPLE[mVp-p]	-20 to +60°C	75max	75max	100max	100max
		*3 -40 to -20°C	100max	100max	120max	120max
	RIPPLE NOISE[mVp-p]	-20 to +60°C	75max	75max	100max	100max
		*3 -40 to -20°C	150max	150max	150max	150max
	TEMPERATURE REGULATION[mV]	-20 to +60°C	50max	50max	150max	180max
		-40 to +60°C	80max	80max	240max	290max
	DRIFT[mV] *4	20max	20max	48max	60max	
START-UP TIME[ms]	30max (Minimum input, I _o =100%)					
OUTPUT VOLTAGE ADJUSTMENT RANGE	Fixed (TRM pin open) ±10% adjustable by external VR					
OUTPUT VOLTAGE SETTING[V]*5	3.296 - 3.404	4.975 - 5.137	11.857 - 12.243	14.839 - 15.321		
PROTECTION CIRCUIT AND OTHERS	OVERCURRENT PROTECTION	Works over 105% of rating and recovers automatically				
	OVERVOLTAGE PROTECTION	Works over 120 to 160% of rating				
	REMOTE ON/OFF	Provided (Negative logic L:ON, H:OFF)				

GENERAL SPECIFICATIONS

ISOLATION	INPUT-OUTPUT	DC1,500V 1minute, Cutoff current = 10mA, DC500V 1,000MΩ min (20±15°C)
	INPUT-CASE	DC1,000V 1minute, Cutoff current = 10mA, DC500V 1,000MΩ min (20±15°C)
	OUTPUT-CASE	DC1,000V 1minute, Cutoff current = 10mA, DC500V 1,000MΩ min (20±15°C)
ENVIRONMENT	OPERATING TEMP., HUMID. AND ALTITUDE	-40 to +85°C, 20 to 95%RH (Non condensing) (Refer to "Derating"), 3,000m (10,000feet) max
	STORAGE TEMP., HUMID. AND ALTITUDE	-40 to +100°C, 20 to 95%RH (Non condensing), 9,000m (30,000feet) max
	VIBRATION	10 - 55Hz, 98.0m/s ² (10G), 3minutes period, 60minutes each along X, Y and Z axis
	IMPACT	490.3m/s ² (50G), 11ms, once each along X, Y and Z axis
SAFETY	AGENCY APPROVALS	UL60950-1, C-UL, EN62368-1
OTHERS	CASE SIZE/WEIGHT	25.4 X 9.9 X 50.8mm [1 X 0.39 X 2 inches] (W X H X D) / 40g max
	COOLING METHOD	Convection/Forced air

- *1 MGF30xx05/MGF30xx12/MGF30xx15 is available as single output, +10V/+24V/+30V
- *2 Rated input 12V, 24V or 48V DC I_o=100%
- *3 Ripple and Ripple Noise is measured by using test board with ceramic capacitor 22μF at 50mm from output pins. (20MHz Oscilloscope)
- *4 Drift is the DC output accuracy for eight hours period after a half-hour warm-up at 25°C.
- *5 Rated input voltage (DC24V, DC48V), rated output wattage, ambient temperature at 25°C.
- * Parallel operation with other model is not possible.

External view

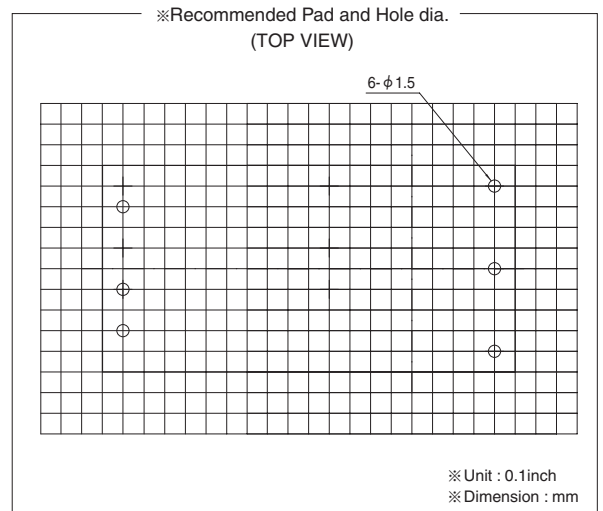
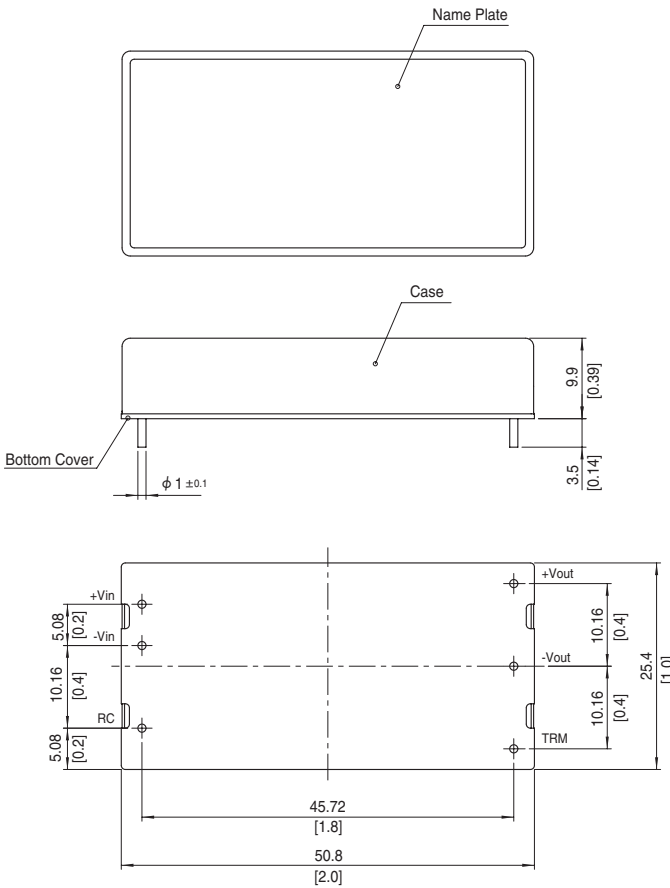

- ※ Tolerance ±0.5 [±0.02]
- ※ Dimensions in mm, []=inches
- ※ Pin terminal material : Copper
- ※ Plating treatment of terminal : Lead free plating
- ※ Case material : Brass
- ※ Plating treatment of case : Nickel plating
- ※ Bottom Cover : FR4 (t=0.6) [t=0.024]
- ※ Please keep enough creepage distance with the pattern on PCB and other components.
- ※ Weight 40g max

MGFW30

MGF W 30 24 05 - □

① ② ③ ④ ⑤ ⑥

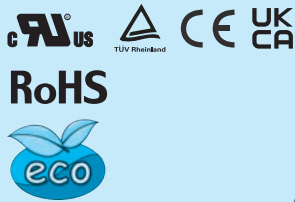

- ① Series name
- ② Dual output
- ③ Output wattage
- ④ Input voltage
- ⑤ Output voltage
- ⑥ Optional
- G: Capacitor between Input and Output is removed.
- R: with Remote ON/OFF (Positive logic control)

MG

MODEL	MGFW302405	MGFW302412	MGFW302415	MGFW304805	MGFW304812	MGFW304815
MAX OUTPUT WATTAGE[W]	20	30	30	20	30	30
DC OUTPUT	VOLTAGE[V] *1	±5 or +10	±12 or +24	±15 or +30	±5 or +10	±12 or +24
	CURRENT[A]	2	1.25	1	2	1.25

SPECIFICATIONS

	MODEL	MGFW302405	MGFW302412	MGFW302415	MGFW304805	MGFW304812	MGFW304815	
INPUT	VOLTAGE[V]	DC9 - 36			DC18 - 76			
	CURRENT[A] *2	0.98typ	1.42typ	1.44typ	0.49typ	0.71typ	0.72typ	
	EFFICIENCY[%] *2	85typ	88typ	87typ	85typ	88typ	87typ	
OUTPUT	VOLTAGE[V]	±5(+10)	±12(+24)	±15(+30)	±5(+10)	±12(+24)	±15(+30)	
	CURRENT[A]	2	1.25	1	2	1.25	1	
	LINE REGULATION[mV]	40max	60max	75max	40max	60max	75max	
	LOAD REGULATION[mV]	*3	500max *5	600max	750max	500max *5	600max	750max
		*4	250max	480max	600max	250max	480max	600max
	RIPPLE[mVp-p] *6	-20 to +60°C	100max	100max	100max	100max	100max	100max
		-40 to -20°C	120max	120max	120max	120max	120max	120max
	RIPPLE NOISE[mVp-p] *6	-20 to +60°C	100max	100max	100max	100max	100max	100max
		-40 to -20°C	150max	150max	150max	150max	150max	150max
	TEMPERATURE REGULATION[mV]	-20 to +60°C	50max	150max	180max	50max	150max	180max
		-40 to +60°C	80max	240max	290max	80max	240max	290max
DRIFT[mV] *7	50max	50max	60max	50max	50max	60max		
START-UP TIME[ms]	30max (Minimum input, Io=100%)							
OUTPUT VOLTAGE SETTING[V]*8	4.935 - 5.240	11.765 - 12.492	14.602 - 15.505	4.935 - 5.240	11.765 - 12.492	14.602 - 15.505		
PROTECTION CIRCUIT AND OTHERS	OVERCURRENT PROTECTION	Works over 105% of rating and recovers automatically						
	OVERVOLTAGE PROTECTION	Works over 120 to 160% of rating (Total of +V and -V)						
	REMOTE ON/OFF	Provided (Negative logic L:ON, H:OFF)						
ISOLATION	INPUT-OUTPUT	DC1,500V 1minute, Cutoff current = 10mA, DC500V 1,000MΩ min (20±15°C)						
	INPUT-CASE	DC1,000V 1minute, Cutoff current = 10mA, DC500V 1,000MΩ min (20±15°C)						
	OUTPUT-CASE	DC1,000V 1minute, Cutoff current = 10mA, DC500V 1,000MΩ min (20±15°C)						
ENVIRONMENT	OPERATING TEMP., HUMID. AND ALTITUDE	-40 to +85°C, 20 to 95%RH (Non condensing) (Refer to "Derating"), 3,000m (10,000feet) max						
	STORAGE TEMP., HUMID. AND ALTITUDE	-40 to +100°C, 20 to 95%RH (Non condensing), 9,000m (30,000feet) max						
	VIBRATION	10 - 55Hz, 98.0m/s ² (10G), 3minutes period, 60minutes each along X, Y and Z axis						
	IMPACT	490.3m/s ² (50G), 11ms, once each along X, Y and Z axis						
SAFETY	AGENCY APPROVALS	UL60950-1, C-UL, EN62368-1						
OTHERS	CASE SIZE/WEIGHT	25.4 × 9.9 × 50.8mm [1 × 0.39 × 2 inches] (W × H × D) / 40g max						
	COOLING METHOD	Convection/Forced air						

*1 Single output +10V, +24V, +30V with no use of COM.

*2 Rated input 12V, 24V or 48V DC Io=100%

*3 Symmetrical loading from 5% to 100%.

*4 Symmetrical loading from 20% to 100%.

*5 Refer to the instruction manual 11.

*6 Ripple and Ripple Noise is measured by using test board with ceramic capacitor 22μF at 50mm from output pins. (20MHz Oscilloscope)

*7 Drift is the DC output accuracy for eight hours period after a half-hour warm-up at 25°C.

*8 Rated input voltage (DC24V, DC48V), rated output wattage, ambient temperature at 25°C.

* Parallel operation with other model is not possible.

External view

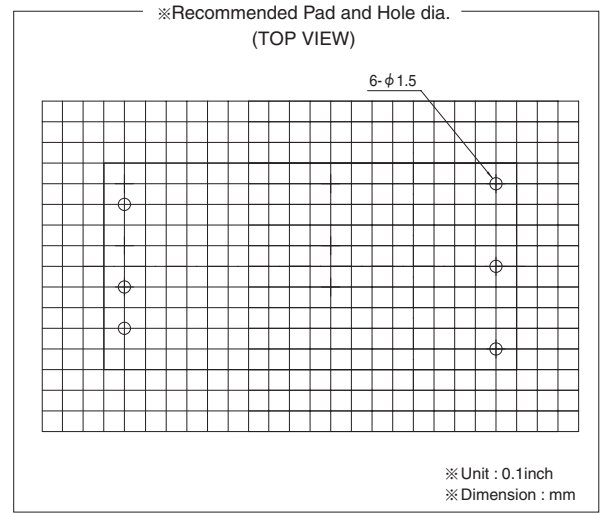
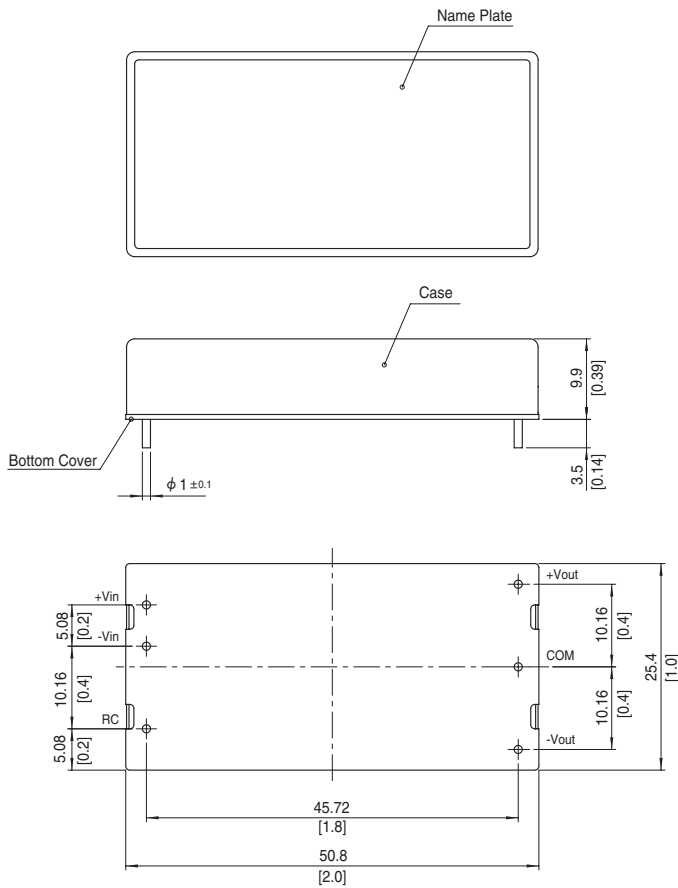

- ※ Tolerance ± 0.5 [± 0.02]
- ※ Dimensions in mm, []=inches
- ※ Pin terminal material : Copper
- ※ Plating treatment of terminal : Lead free plating
- ※ Case material : Brass
- ※ Plating treatment of case : Nickel plating
- ※ Bottom Cover : FR4 (t=0.6) [t=0.024]
- ※ Please keep enough creepage distance with the pattern on PCB and other components.
- ※ Weight 40g max

MG

MGFS40

MGF S 40 24 05 - □

① ② ③ ④ ⑤ ⑥



- ① Series name
- ② Single output
- ③ Output wattage
- ④ Input voltage
- ⑤ Output voltage
- ⑥ Optional
- G: Capacitor between Input and Output is removed.
- R: with Remote ON/OFF (Positive logic control)

MODEL	MGFS40053R3	MGFS400505	MGFS400512	MGFS400515	MGFS40243R3	MGFS402405	MGFS402412	MGFS402415
MAX OUTPUT WATTAGE[W]	26.4	30	30	30	33	40	40.8	40.5
DC OUTPUT	VOLTAGE[V] *1	3.3	5	12	15	3.3	5	12
	CURRENT[A]	8	6	2.5	2	10	8	3.4

SPECIFICATIONS

	MODEL	MGFS40053R3	MGFS400505	MGFS400512	MGFS400515	MGFS40243R3	MGFS402405	MGFS402412	MGFS402415	
INPUT	VOLTAGE[V]	DC4.5 - 13 (Surge Voltage 15V, 100ms max)				DC9 - 36 (Surge Voltage 50V, 100ms max)				
	CURRENT[A] *2	6.21typ	6.90typ	6.90typ	6.82typ	1.54typ	1.83typ	1.85typ	1.83typ	
	EFFICIENCY[%] *2	85typ	87typ	87typ	88typ	89typ	91typ	92typ	92typ	
OUTPUT	VOLTAGE[V]	3.3	5	12	15	3.3	5	12	15	
	CURRENT[A]	8	6	2.5	2	10	8	3.4	2.7	
	LINE REGULATION[mV]	13.2max	20max	48max	60max	13.2max	20max	48max	60max	
	LOAD REGULATION[mV]	13.2max	20max	48max	60max	13.2max	20max	48max	60max	
	RIPPLE[mVp-p]	-20 to +60°C	75max	75max	100max	100max	75max	75max	100max	100max
		*3 -40 to -20°C	100max	100max	120max	120max	100max	100max	120max	120max
	RIPPLE NOISE[mVp-p]	-20 to +60°C	75max	75max	100max	100max	75max	75max	100max	100max
		*3 -40 to -20°C	150max	150max	150max	150max	150max	150max	150max	150max
	TEMPERATURE REGULATION[mV]	-20 to +60°C	50max	50max	150max	180max	50max	50max	150max	180max
		-40 to +60°C	80max	80max	240max	290max	80max	80max	240max	290max
DRIFT[mV]	*4	20max	20max	48max	60max	20max	20max	48max	60max	
START-UP TIME[ms]		30max (Minimum input, Rated load)								
OUTPUT VOLTAGE ADJUSTMENT RANGE		Fixed (TRM pin open) ±10% adjustable by external VR								
OUTPUT VOLTAGE SETTING[V]*5		3.296 - 3.404	4.975 - 5.137	11.857 - 12.243	14.839 - 15.321	3.296 - 3.404	4.975 - 5.137	11.857 - 12.243	14.839 - 15.321	
PROTECTION CIRCUIT AND OTHERS	OVERCURRENT PROTECTION	Works over 105% of rating and recovers automatically								
	OVERVOLTAGE PROTECTION	Work over 115 to 140% of rating								
	REMOTE ON/OFF	Provided (Negative logic L:ON, H:OFF)								

MODEL	MGFS40483R3	MGFS404805	MGFS404812	MGFS404815
MAX OUTPUT WATTAGE[W]	33	40	40.8	40.5
DC OUTPUT	VOLTAGE[V] *1	3.3	5	12
	CURRENT[A]	10	8	3.4

SPECIFICATIONS

	MODEL	MGFS40483R3	MGFS404805	MGFS404812	MGFS404815	
INPUT	VOLTAGE[V]	DC18 - 76 (Surge Voltage 100V, 100ms max)				
	CURRENT[A] *2	0.77typ	0.92typ	0.92typ	0.92typ	
	EFFICIENCY[%] *2	89typ	91typ	92typ	92typ	
OUTPUT	VOLTAGE[V]	3.3	5	12	15	
	CURRENT[A]	10	8	3.4	2.7	
	LINE REGULATION[mV]	13.2max	20max	48max	60max	
	LOAD REGULATION[mV]	13.2max	20max	48max	60max	
	RIPPLE[mVp-p]	-20 to +60°C	75max	75max	100max	100max
		*3 -40 to -20°C	100max	100max	120max	120max
	RIPPLE NOISE[mVp-p]	-20 to +60°C	75max	75max	100max	100max
		*3 -40 to -20°C	150max	150max	150max	150max
	TEMPERATURE REGULATION[mV]	-20 to +60°C	50max	50max	150max	180max
		-40 to +60°C	80max	80max	240max	290max
DRIFT[mV]	*4	20max	20max	48max	60max	
START-UP TIME[ms]		30max (Minimum input, Rated load)				
OUTPUT VOLTAGE ADJUSTMENT RANGE		Fixed (TRM pin open) ±10% adjustable by external VR				
OUTPUT VOLTAGE SETTING[V]*5		3.296 - 3.404	4.975 - 5.137	11.857 - 12.243	14.839 - 15.321	
PROTECTION CIRCUIT AND OTHERS	OVERCURRENT PROTECTION	Works over 105% of rating and recovers automatically				
	OVERVOLTAGE PROTECTION	Work over 115 to 140% of rating				
	REMOTE ON/OFF	Provided (Negative logic L:ON, H:OFF)				

GENERAL SPECIFICATIONS

ISOLATION	INPUT-OUTPUT	DC1,500V 1minute, Cutoff current = 10mA, DC500V 1,000MΩ min (20±15°C)
	INPUT-CASE	DC1,000V 1minute, Cutoff current = 10mA, DC500V 1,000MΩ min (20±15°C)
	OUTPUT-CASE	DC1,000V 1minute, Cutoff current = 10mA, DC500V 1,000MΩ min (20±15°C)
ENVIRONMENT	OPERATING TEMP.,HUMID.AND ALTITUDE	-40 to +85°C, 20 to 95%RH (Non condensing) (Refer to "Derating"), 5,000m (16,400feet) max
	STORAGE TEMP.,HUMID.AND ALTITUDE	-40 to +100°C, 20 to 95%RH (Non condensing), 9,000m (30,000feet) max
	VIBRATION	10 - 55Hz, 98.0m/s ² (10G), 3minutes period, 60minutes each along X, Y and Z axis
	IMPACT	490.3m/s ² (50G), 11ms, once each along X, Y and Z axis
SAFETY	AGENCY APPROVALS	UL62368-1, C-UL(CSA62368-1), EN62368-1
OTHERS	CASE SIZE/WEIGHT	25.4 X 9.9 X 25.4mm (W X H X D) / 30g max
	COOLING METHOD	Convection/Forced air

- *1 MGF40xx12/MGF40xx15 is available as single output +24V/+30V
- *2 Rated input voltage (DC5V, DC24V, DC48V) Io=100%
- *3 Riple and Ripple Noise is measured by using test board with ceramic capacitor 22μF and Recommended Capacitance at 50mm from output pins. (20MHz Oscilloscope)
- *4 Drift is the DC output accuracy for eight hour period after a half-hour warm-up at 25°C
- *5 Rated input voltage (DC5V, DC24V, DC48V), rated output wattage, ambient temperature at 25°C
- * Parallel operation with other model is not possible.

External view

MG

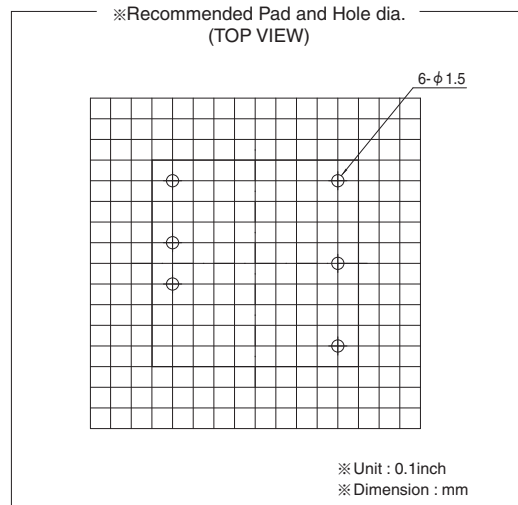
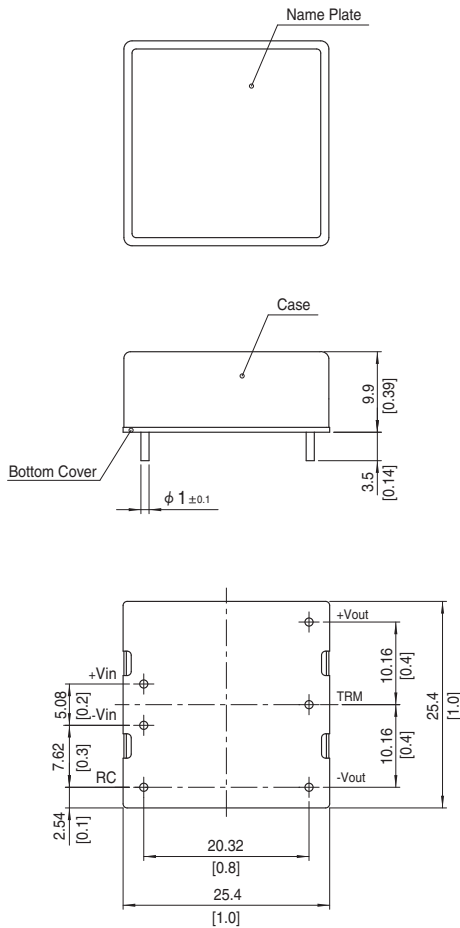

- ※ Tolerance ±0.5 [±0.02]
- ※ Dimensions in mm, []=inches
- ※ Pin terminal material : Copper
- ※ Plating treatment of terminal : Lead free plating
- ※ Case material : Brass
- ※ Plating treatment of case : Nickel plating
- ※ Bottom Cover : FR4 (t=0.6) [t=0.024]
- ※ Please keep enough creepage distance with the pattern on PCB and other components.
- ※ Weight 30g max

MGFW40

MGF W 40 24 12 - □

① ② ③ ④ ⑤ ⑥



- ① Series name
- ② Dual output
- ③ Output wattage
- ④ Input voltage
- ⑤ Output voltage
- ⑥ Optional
- G: Capacitor between Input and Output is removed.
- R: with Remote ON/OFF (Positive logic control)

MODEL	MGFW400512	MGFW400515	MGFW402412	MGFW402415	MGFW404812	MGFW404815	
MAX OUTPUT WATTAGE[W]	31.2	30	40.8	42	40.8	42	
DC OUTPUT	VOLTAGE[V] *1	±12 or +24	±15 or +30	±12 or +24	±15 or +30	±12 or +24	±15 or +30
	CURRENT[A]	1.3	1	1.7	1.4	1.7	1.4

SPECIFICATIONS

	MODEL	MGFW400512	MGFW400515	MGFW402412	MGFW402415	MGFW404812	MGFW404815	
INPUT	VOLTAGE[V]	DC4.5 - 13 (Surge Voltage 15V, 100ms max)		DC9 - 36 (Surge Voltage 50V, 100ms max)		DC18 - 76 (Surge Voltage 100V, 100ms max)		
	CURRENT[A] *2	7.26typ	6.90typ	1.87typ	1.92typ	0.93typ	0.96typ	
	EFFICIENCY[%] *2	86typ	87typ	91typ	91typ	91typ	91typ	
OUTPUT	VOLTAGE[V]	±12(+24)	±15(+30)	±12(+24)	±15(+30)	±12(+24)	±15(+30)	
	CURRENT[A]	1.3	1	1.7	1.4	1.7	1.4	
	LINE REGULATION[mV]	60max	75max	60max	75max	60max	75max	
	LOAD REGULATION[mV]	*3	600max	750max	600max	750max	600max	750max
		*4	480max	600max	480max	600max	480max	600max
	RIPPLE[mVp-p] *5	-20 to +60°C	100max	100max	100max	100max	100max	100max
		-40 to -20°C	120max	120max	120max	120max	120max	120max
	RIPPLE NOISE[mVp-p] *5	-20 to +60°C	100max	100max	100max	100max	100max	100max
		-40 to -20°C	150max	150max	150max	150max	150max	150max
	TEMPERATURE REGULATION[mV]	-20 to +60°C	150max	180max	150max	180max	150max	180max
		-40 to +60°C	240max	290max	240max	290max	240max	290max
DRIFT[mV] *6	50max	60max	50max	60max	50max	60max		
START-UP TIME[ms]	30max (Minimum input, Rated load)							
OUTPUT VOLTAGE SETTING[V]*7	11.765 - 12.492	14.602 - 15.505	11.765 - 12.492	14.602 - 15.505	11.765 - 12.492	14.602 - 15.505		
PROTECTION CIRCUIT AND OTHERS	OVERCURRENT PROTECTION	Works over 105% of rating and recovers automatically						
	OVERVOLTAGE PROTECTION	Work over 115 to 140% of rating (Total of +Vo and -Vo)						
	REMOTE ON/OFF	Provided (Negative logic L:ON, H:OFF)						
ISOLATION	INPUT-OUTPUT	DC1,500V 1minute, Cutoff current = 10mA, DC500V 1,000MΩ min (20±15°C)						
	INPUT-CASE	DC1,000V 1minute, Cutoff current = 10mA, DC500V 1,000MΩ min (20±15°C)						
	OUTPUT-CASE	DC1,000V 1minute, Cutoff current = 10mA, DC500V 1,000MΩ min (20±15°C)						
ENVIRONMENT	OPERATING TEMP., HUMID. AND ALTITUDE	-40 to +85°C, 20 to 95%RH (Non condensing) (Refer to "Derating"), 5,000m (16,400feet) max						
	STORAGE TEMP., HUMID. AND ALTITUDE	-40 to +100°C, 20 to 95%RH (Non condensing), 9,000m (30,000feet) max						
	VIBRATION	10 - 55Hz, 98.0m/s ² (10G), 3minutes period, 60minutes each along X, Y and Z axis						
	IMPACT	490.3m/s ² (50G), 11ms, once each along X, Y and Z axis						
SAFETY	AGENCY APPROVALS	UL62368-1, C-UL (CSA62368-1), EN62368-1						
OTHERS	CASE SIZE/WEIGHT	25.4 × 9.9 × 25.4mm (W × H × D) / 30g max						
	COOLING METHOD	Convection/Forced air						

*1 Single output +24V/+30V with no use of COM

*2 Rated input voltage(DC5V, DC24V, DC48V) Io=100%

*3 Symmetrical loading from 0% to 100%

*4 Symmetrical loading from 20% to 100%

*5 Ripple and Ripple Noise is measured by using test board with ceramic capacitor 22μF and Recommended Capacitance at 50mm from output pins. (20MHz Oscilloscope)

*6 Drift is the DC output accuracy for eight hour period after a half-hour warm-up at 25°C

*7 Rated input voltage (DC5V, DC24V, DC48V), rated output wattage, ambient temperature at 25°C

* Parallel operation with other model is not possible.

External view

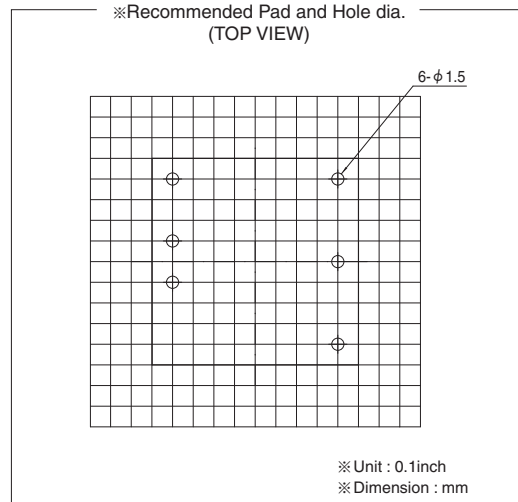
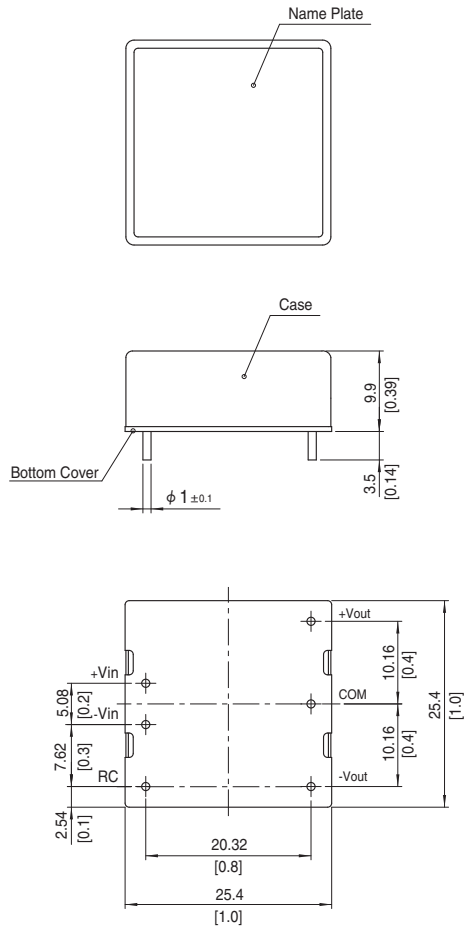

- ※ Tolerance ± 0.5 [± 0.02]
- ※ Dimensions in mm, []=inches
- ※ Pin terminal material : Copper
- ※ Plating treatment of terminal : Lead free plating
- ※ Case material : Brass
- ※ Plating treatment of case : Nickel plating
- ※ Bottom Cover : FR4 (t=0.6) [t=0.024]
- ※ Please keep enough creepage distance with the pattern on PCB and other components.
- ※ Weight 30g max

MG

MGFS80

MGF S 80 24 05 -□

① ② ③ ④ ⑤ ⑥



- ① Series name
- ② Single output
- ③ Output wattage
- ④ Input voltage
- ⑤ Output voltage
- ⑥ Optional
- G: Capacitor between Input and Output is removed.
- R: with Remote ON/OFF (Positive logic control)

MODEL	MGFS80243R3	MGFS802405	MGFS802412	MGFS802415
MAX OUTPUT WATTAGE[W]	59.4	80	80.4	81
DC OUTPUT	VOLTAGE[V] *1	3.3	5	12
	CURRENT[A]	18	16	6.7
				5.4

SPECIFICATIONS

	MODEL	MGFS80243R3	MGFS802405	MGFS802412	MGFS802415	
INPUT	VOLTAGE[V]	DC9 - 36 (Surge Voltage 50V, 100ms max)				
	CURRENT[A] *2	2.69typ	3.60typ	3.56typ	3.59typ	
	EFFICIENCY[%] *2	92typ	93typ	94typ	94typ	
OUTPUT	VOLTAGE[V]	3.3	5	12	15	
	CURRENT[A]	18	16	6.7	5.4	
	LINE REGULATION[mV]	13.2max	20max	48max	60max	
	LOAD REGULATION[mV]	20max	20max	48max	60max	
	RIPPLE[mVp-p] *3	-20 to +60°C	75max	75max	100max	100max
		-40 to -20°C	100max	100max	120max	120max
		Io=0 to 10%	200max	200max	240max	240max
	RIPPLE NOISE[mVp-p] *3	-20 to +60°C	75max	75max	100max	100max
		-40 to -20°C	150max	150max	150max	150max
		Io=0 to 10%	250max	250max	270max	270max
	TEMPERATURE REGULATION[mV]	-20 to +60°C	50max	50max	150max	180max
		-40 to +60°C	80max	80max	240max	290max
	DRIFT[mV] *4	20max	20max	48max	60max	
START-UP TIME[ms]	30max (Minimum input, Rated load)					
OUTPUT VOLTAGE ADJUSTMENT RANGE	Fixed (TRM pin open) ±10% adjustable by external VR					
OUTPUT VOLTAGE SETTING[V]*5	3.296 - 3.404	4.975 - 5.137	11.857 - 12.243	14.839 - 15.321		
PROTECTION CIRCUIT AND OTHERS	OVERCURRENT PROTECTION	Works over 105% of rating and recovers automatically				
	OVERVOLTAGE PROTECTION	Work over 115 to 140% of rating				
	REMOTE ON/OFF	Provided (Negative logic L:ON, H:OFF)				

MODEL	MGFS80483R3	MGFS804805	MGFS804812	MGFS804815
MAX OUTPUT WATTAGE[W]	59.4	80	80.4	81
DC OUTPUT	VOLTAGE[V] *1	3.3	5	12
	CURRENT[A]	18	16	6.7
				5.4

SPECIFICATIONS

	MODEL	MGFS80483R3	MGFS804805	MGFS804812	MGFS804815	
INPUT	VOLTAGE[V]	DC18 - 76 (Surge Voltage 100V, 100ms max)				
	CURRENT[A] *2	1.35typ	1.80typ	1.78typ	1.80typ	
	EFFICIENCY[%] *2	92typ	93typ	94typ	94typ	
OUTPUT	VOLTAGE[V]	3.3	5	12	15	
	CURRENT[A]	18	16	6.7	5.4	
	LINE REGULATION[mV]	13.2max	20max	48max	60max	
	LOAD REGULATION[mV]	20max	20max	48max	60max	
	RIPPLE[mVp-p] *3	-20 to +60°C	75max	75max	100max	100max
		-40 to -20°C	100max	100max	120max	120max
		Io=0 to 10%	200max	200max	240max	240max
	RIPPLE NOISE[mVp-p] *3	-20 to +60°C	75max	75max	100max	100max
		-40 to -20°C	150max	150max	150max	150max
		Io=0 to 10%	250max	250max	270max	270max
	TEMPERATURE REGULATION[mV]	-20 to +60°C	50max	50max	150max	180max
		-40 to +60°C	80max	80max	240max	290max
	DRIFT[mV] *4	20max	20max	48max	60max	
START-UP TIME[ms]	30max (Minimum input, Rated load)					
OUTPUT VOLTAGE ADJUSTMENT RANGE	Fixed (TRM pin open) ±10% adjustable by external VR					
OUTPUT VOLTAGE SETTING[V]*5	3.296 - 3.404	4.975 - 5.137	11.857 - 12.243	14.839 - 15.321		
PROTECTION CIRCUIT AND OTHERS	OVERCURRENT PROTECTION	Works over 105% of rating and recovers automatically				
	OVERVOLTAGE PROTECTION	Work over 115 to 140% of rating				
	REMOTE ON/OFF	Provided (Negative logic L:ON, H:OFF)				

GENERAL SPECIFICATIONS

ISOLATION	INPUT-OUTPUT	DC1,500V 1minute, Cutoff current = 10mA, DC500V 1,000MΩ min (20±15°C)
	INPUT-CASE	DC1,000V 1minute, Cutoff current = 10mA, DC500V 1,000MΩ min (20±15°C)
	OUTPUT-CASE	DC1,000V 1minute, Cutoff current = 10mA, DC500V 1,000MΩ min (20±15°C)
ENVIRONMENT	OPERATING TEMP., HUMID. AND ALTITUDE	-40 to +85°C, 20 to 95%RH (Non condensing) (Refer to "Derating"), 5,000m (16,400feet) max
	STORAGE TEMP., HUMID. AND ALTITUDE	-40 to +100°C, 20 to 95%RH (Non condensing), 9,000m (30,000feet) max
	VIBRATION	10 - 55Hz, 98.0m/s ² (10G), 3minutes period, 60minutes each along X, Y and Z axis
	IMPACT	490.3m/s ² (50G), 11ms, once each along X, Y and Z axis
SAFETY	AGENCY APPROVALS	UL62368-1, C-UL(CSA62368-1), EN62368-1
OTHERS	CASE SIZE/WEIGHT	25.4 X 9.9 X 50.8mm (W X H X D) / 50g max
	COOLING METHOD	Convection/Forced air

- *1 MGFW80xx12/MGFW80xx15 is available as single output +24V/+30V
- *2 Rated input voltage (DC24V, DC48V) Io=100%
- *3 Ripple and Ripple Noise is measured by using test board with ceramic capacitor 22μF and Recommended Capacitance at 50mm from output pins. (20MHz Oscilloscope)
- *4 Drift is the DC output accuracy for eight hour period after a half-hour warm-up at 25°C
- *5 Rated input voltage (DC24V, DC48V), rated output wattage, ambient temperature at 25°C
- * Parallel operation with other model is not possible.

External view

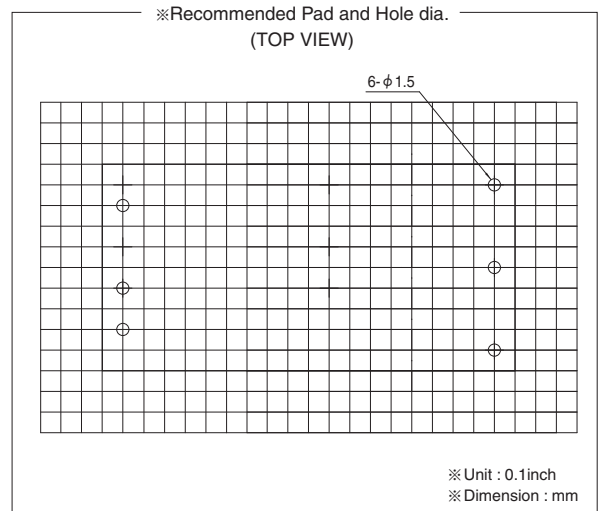
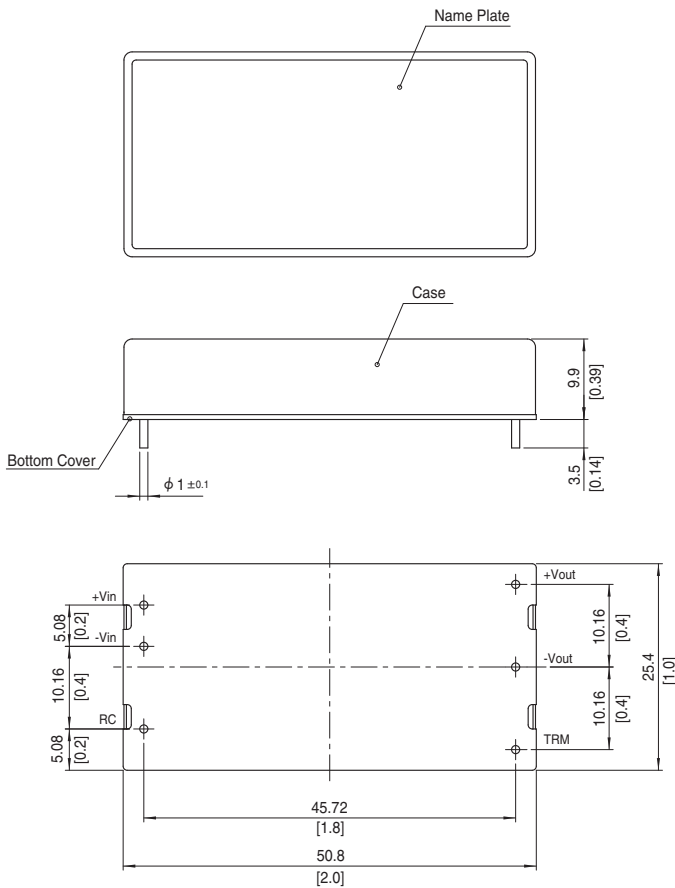

- ※ Tolerance ±0.5 [±0.02]
- ※ Dimensions in mm, []=inches
- ※ Pin terminal material : Copper
- ※ Plating treatment of terminal : Lead free plating
- ※ Case material : Brass
- ※ Plating treatment of case : Nickel plating
- ※ Bottom Cover : FR4 (t=0.6) [t=0.024]
- ※ Please keep enough creepage distance with the pattern on PCB and other components.
- ※ Weight 50g max

MGFW80

MGF W 80 24 12 - □

① ② ③ ④ ⑤ ⑥



- ① Series name
- ② Dual output
- ③ Output wattage
- ④ Input voltage
- ⑤ Output voltage
- ⑥ Optional
- G: Capacitor between Input and Output is removed.
- R: with Remote ON/OFF (Positive logic control)

MODEL	MGFW802412	MGFW802415	MGFW804812	MGFW804815
MAX OUTPUT WATTAGE[W]	81.6	81	81.6	81
DC OUTPUT	VOLTAGE[V] *1	±12 or +24	±15 or +30	±15 or +30
	CURRENT[A]	3.4	2.7	3.4

SPECIFICATIONS

	MODEL	MGFW802412	MGFW802415	MGFW804812	MGFW804815	
INPUT	VOLTAGE[V]	DC9 - 36 (Surge Voltage 50V, 100ms max)		DC18 - 76 (Surge Voltage 100V, 100ms max)		
	CURRENT[A] *2	3.62typ	3.59typ	1.81typ	1.80typ	
	EFFICIENCY[%] *2	94typ	94typ	94typ	94typ	
OUTPUT	VOLTAGE[V]	±12 or +24	±15 or +30	±12 or +24	±15 or +30	
	CURRENT[A]	3.4	2.7	3.4	2.7	
	LINE REGULATION[mV]	60max	75max	60max	75max	
	LOAD REGULATION[mV]	*3	600max	750max	600max	750max
		*4	480max	600max	480max	600max
	RIPPLE[mVp-p] *5	-20 to +60°C	100max	100max	100max	100max
		-40 to -20°C	120max	120max	120max	120max
		Io=0 to 10%	240max	240max	240max	240max
	RIPPLE NOISE[mVp-p] *5	-20 to +60°C	100max	100max	100max	100max
		-40 to -20°C	150max	150max	150max	150max
		Io=0 to 10%	270max	270max	270max	270max
TEMPERATURE REGULATION[mV]	-20 to +60°C	150max	180max	150max	180max	
	-40 to +60°C	240max	290max	240max	290max	
DRIFT[mV] *6	50max	60max	50max	60max		
START-UP TIME[ms]	30max (Minimum input, Rated load)					
OUTPUT VOLTAGE SETTING[V]*7	11.765 - 12.492	14.602 - 15.505	11.765 - 12.492	14.602 - 15.505		
PROTECTION CIRCUIT AND OTHERS	OVERCURRENT PROTECTION	Works over 105% of rating and recovers automatically				
	OVERVOLTAGE PROTECTION	Work over 115 to 140% of rating (Total of +Vo and -Vo)				
	REMOTE ON/OFF	Provided (Negative logic L:ON, H:OFF)				
ISOLATION	INPUT-OUTPUT	DC1,500V 1minute, Cutoff current = 10mA, DC500V 1,000MΩ min (20±15°C)				
	INPUT-CASE	DC1,000V 1minute, Cutoff current = 10mA, DC500V 1,000MΩ min (20±15°C)				
	OUTPUT-CASE	DC1,000V 1minute, Cutoff current = 10mA, DC500V 1,000MΩ min (20±15°C)				
ENVIRONMENT	OPERATING TEMP., HUMID. AND ALTITUDE	-40 to +85°C, 20 to 95%RH (Non condensing) (Refer to "Derating"), 5,000m (16,400feet) max				
	STORAGE TEMP., HUMID. AND ALTITUDE	-40 to +100°C, 20 to 95%RH (Non condensing), 9,000m (30,000feet) max				
	VIBRATION	10 - 55Hz, 98.0m/s ² (10G), 3minutes period, 60minutes each along X, Y and Z axis				
	IMPACT	490.3m/s ² (50G), 11ms, once each along X, Y and Z axis				
SAFETY	AGENCY APPROVALS	UL62368-1, C-UL (CSA62368-1), EN62368-1				
OTHERS	CASE SIZE/WEIGHT	25.4 × 9.9 × 50.8mm (W × H × D) / 50g max				
	COOLING METHOD	Convection/Forced air				

*1 Single output +24V/+30V with no use of COM
 *2 Rated input voltage (DC24V, DC48V) Io=100%
 *3 Symmetrical loading from 0% to 100%
 *4 Symmetrical loading from 20% to 100%
 *5 Ripple and Ripple Noise is measured by using test board with ceramic capacitor 22μF and

*6 Drift is the DC output accuracy for eight hour period after a half-hour warm-up at 25°C
 *7 Rated input voltage (DC24V, DC48V), rated output wattage, ambient temperature at 25°C
 * Parallel operation with other model is not possible.

External view

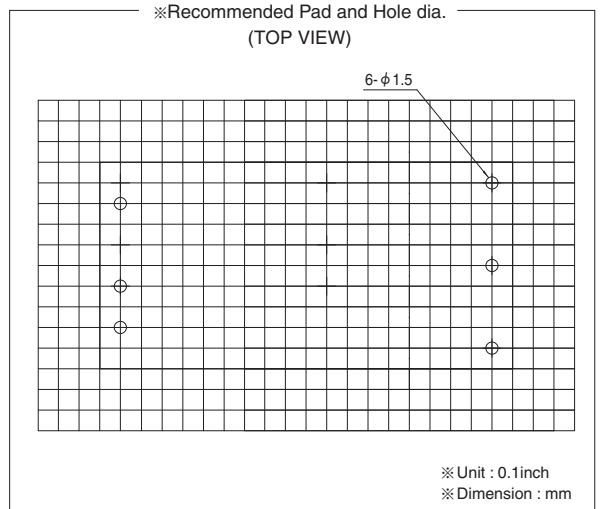
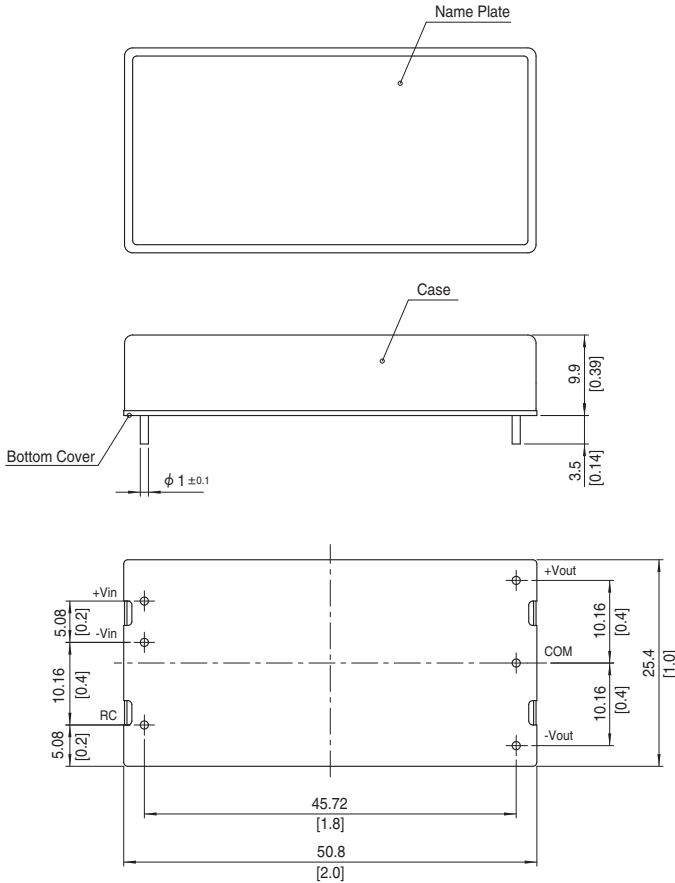

- ※ Tolerance ± 0.5 [± 0.02]
- ※ Dimensions in mm, []=inches
- ※ Pin terminal material : Copper
- ※ Plating treatment of terminal : Lead free plating
- ※ Case material : Brass
- ※ Plating treatment of case : Nickel plating
- ※ Bottom Cover : FR4 (t=0.6) [t=0.024]
- ※ Please keep enough creepage distance with the pattern on PCB and other components.
- ※ Weight 50g max

MG

Pin configuration

●MG15/MG40 Single Output and Dual (\pm) Output

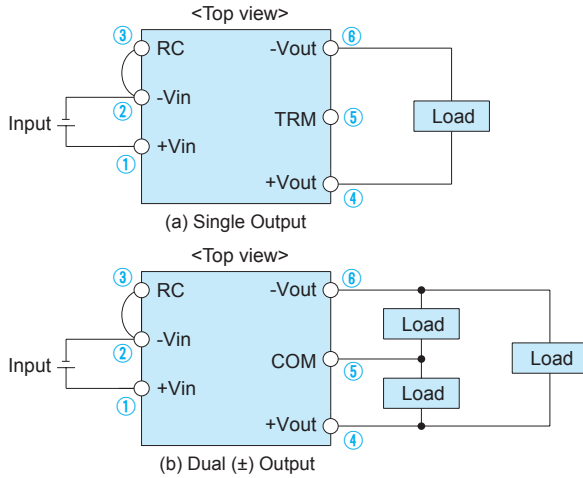

Pin No.	Pin Name	Function
①	+Vin	+DC Input
②	-Vin	-DC Input
③	RC	Remote ON/OFF
④	+Vout	+DC Output
⑤	TRM	Output Voltage Adjustment (Refer to instruction manual 1.5)
	COM	GND of Output Voltage (for Dual Output)
⑥	-Vout	-DC Output

●MG30/MG80 Single Output and Dual (\pm) Output

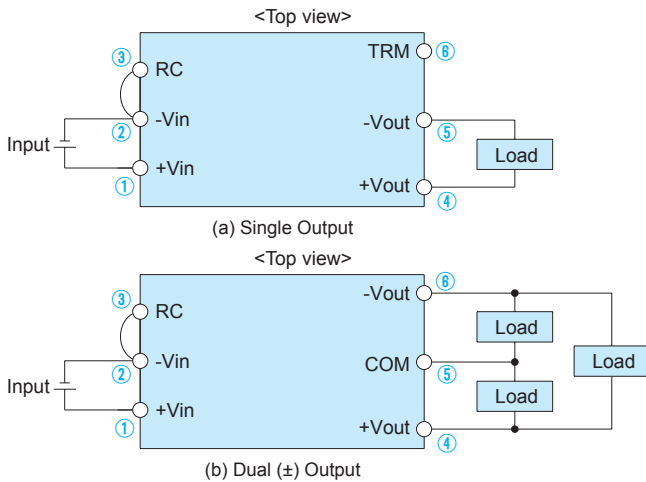

Pin No.	Pin Name	Function
①	+Vin	+DC Input
②	-Vin	-DC Input
③	RC	Remote ON/OFF
④	+Vout	+DC Output
⑤	-Vout	-DC Output (for Single Output)
	COM	GND of Output Voltage (for Dual Output)
⑥	TRM	Output Voltage Adjustment (Refer to instruction manual 1.5)
	-Vout	-DC Output (for Dual Output)

Assembling and Installation Method

Installation

■When two or more power supplies are used side by side, position them with proper intervals to allow enough air ventilation. Ambient temperature around each power supply should not exceed the temperature range shown in "Derating".

Soldering Conditions

- (1) Flow Soldering : 260°C 15 seconds or less
- (2) Soldering Iron : maximum 360°C 5 seconds or less

Stress to Pin

- Applying excessive stress to the input or output pins of the power module may damage internal connections. Avoid applying stress in excess of that shown in right figure.
- Input/output pin are soldered to the PCB internally. Do not pull or bend a lead powerfully.
- If it is expected that stress is applied to the input/output pin due to vibration or impact, reduce the stress to the pin by taking such measures as fixing the unit to the PCB by silicone rubber, etc.
- Due to prevent failure, PS should not be pulled after soldering with PCB.

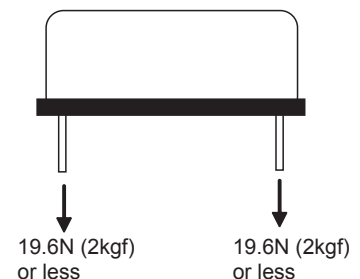

Derating

Derating curve for input voltage

● MGF 4005 □

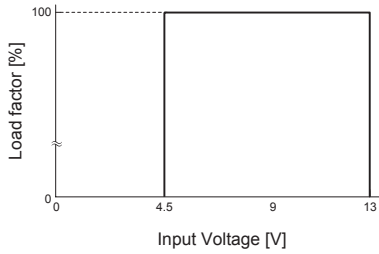

● MGF 4024 □, MGF 4048 □, MGF 8024 □ and MGF 8048 □

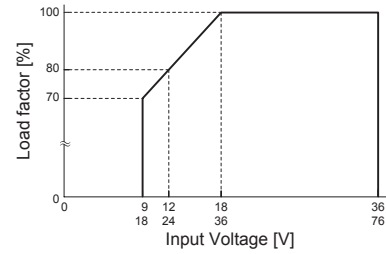

Ambient temperature derating curve

■ It is necessary to note thermal fatigue risk by power cycle. Please reduce the temperature fluctuation range as much as possible when the up and down of temperature are frequently generated.

■ In case of forced air, ventilation must keep the temperature of point below the temperatures shown in Instruction Manual 7.

● MG15/MGF15 (Rated Input Voltage)

(1) In the case of Convection Cooling

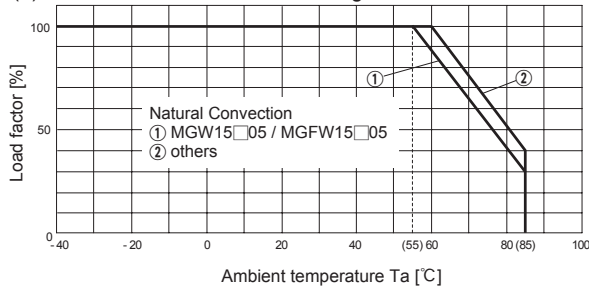

(2) In the case of Forced Air Cooling (1.0m/s)
(Excluding MGW15□05/MGFW15□05)

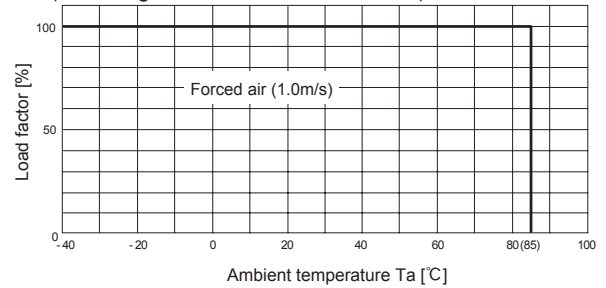

(3) In the case of Forced Air Cooling (1.0m/s, 2.5m/s)
(MGW15□05/MGFW15□05)

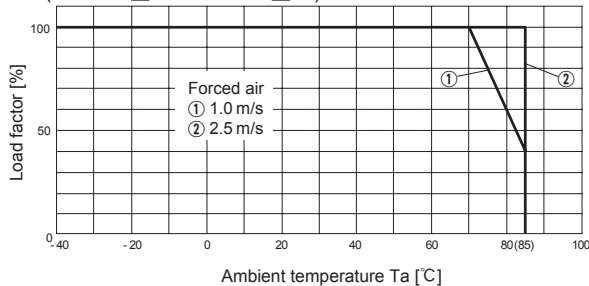

● MG30/MGF30 (Rated Input Voltage)

(1) In the case of Convection Cooling

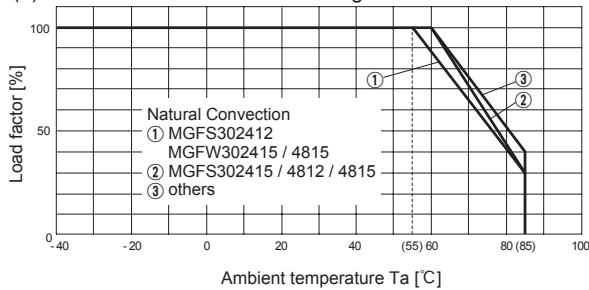

(2) In the case of Forced Air Cooling (1.0m/s)
(Excluding MGW30□05 and MGFW30□12/15)

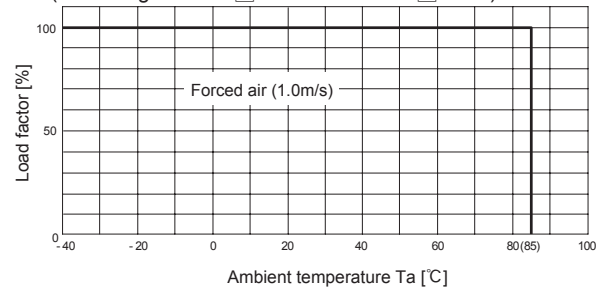

(3) In the case of Forced Air Cooling (1.0m/s, 1.5m/s)
(MGW30□05 and MGFW30□12/15)

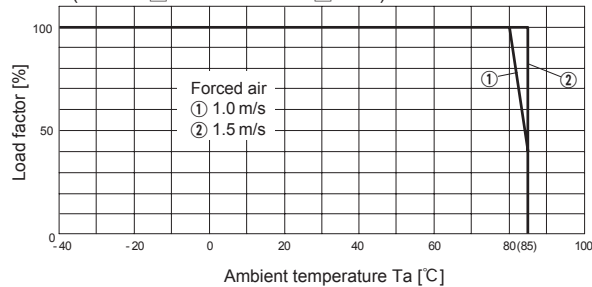

MG

Derating

●MGF40 (Rated Input Voltage)

(1) In the case of Convection Cooling

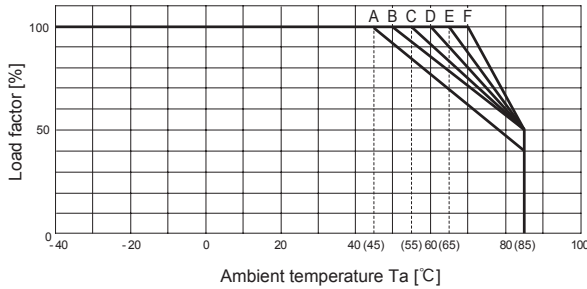

(2) In the case of Forced Air Cooling (1.0m/s)

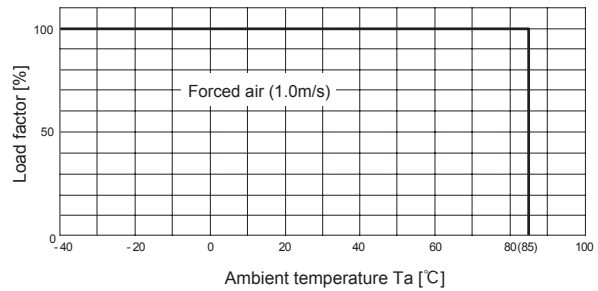

Input Voltage[V]	Output Voltage[V]					
	3.3	5	12	15	±12	±15
5	B	A	B	C	B	B
24	E	D	E	F	E	E
48	F	D	F	E	E	E

●MGF80 (Rated Input Voltage)

(1) In the case of Convection Cooling

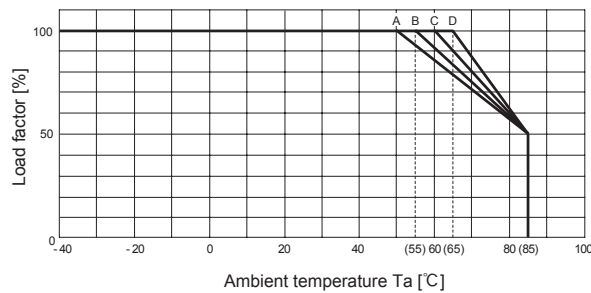

(2) In the case of Forced Air Cooling (1.0m/s)

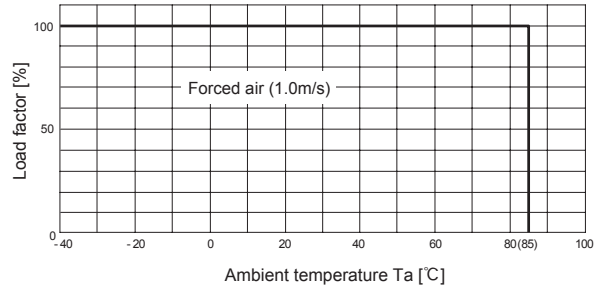

Input Voltage[V]	Output Voltage[V]					
	3.3	5	12	15	±12	±15
24	B	A	C	C	C	C
48	C	B	C	D	C	C

Instruction Manual

- ◆ It is necessary to read the "Instruction Manual" and "Before using our product" before you use our product.

Instruction Manual	https://www.cosel.co.jp/redirect/catalog/en/MGS/
Instruction Manual	https://www.cosel.co.jp/redirect/catalog/en/MGW/
Instruction Manual	https://www.cosel.co.jp/redirect/catalog/en/MGFS/
Instruction Manual	https://www.cosel.co.jp/redirect/catalog/en/MGFW/
Before using our product	https://en.cosel.co.jp/technical/caution/index.html



Basic Characteristics Data

Model	Circuit method	Switching frequency [kHz] (reference)	Input current [A]	Inrush current protection	PCB/Pattern			Series/Parallel operation availability	
					Material	Single sided	Double sided	Series operation	Parallel operation
MG15	Flyback converter	445-495	*1	-	glass fabric base,epoxy resin		Yes	Yes	*2
MGF15	Flyback converter	445-495	*1	-	glass fabric base,epoxy resin		Yes	Yes	*2
MG30	Forward converter	380-460	*1	-	glass fabric base,epoxy resin		Yes	Yes	*2
MGF30	Forward converter	380-460	*1	-	glass fabric base,epoxy resin		Yes	Yes	*2
MGF40	Flyback converter	100-1500 *3	*1	-	glass fabric base,epoxy resin		Yes	Yes	*2
MGF80	Flyback converter	100-1500 *3	*1	-	glass fabric base,epoxy resin		Yes	Yes	*2

*1 Refer to Specification.

*2 Refer to Instruction Manual.

*3 The value changes depending on input and load.



Isolated



Safety Approvals



OCP



Remote ON/OFF



Wide 4:1 input



Medical electric equipment

MH-series

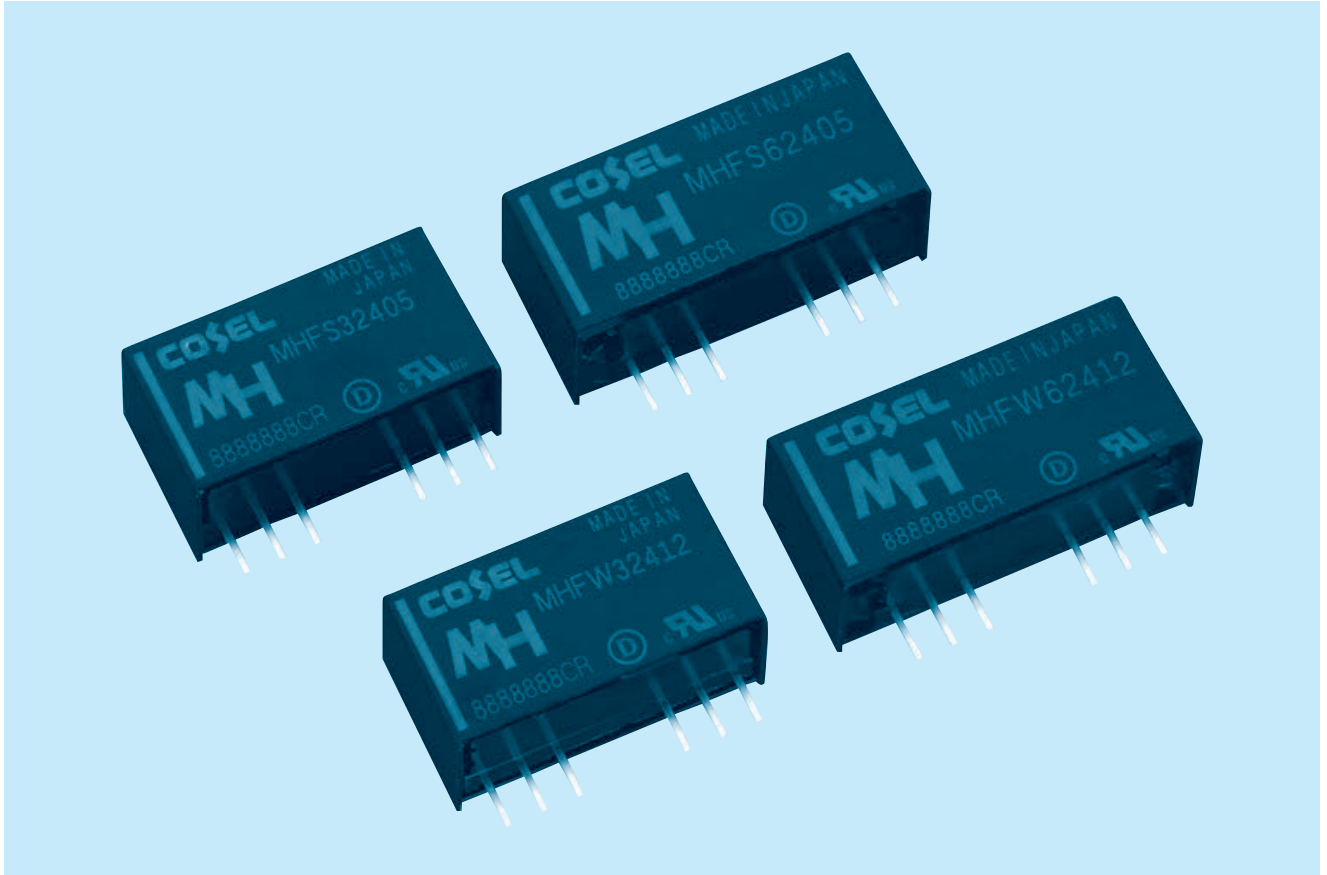

MH

Feature

- Industry Standard SIP8
- Wide input range DC4.5-18V/DC9-36V//DC18-76V
- I/O isolation voltage AC3,000V (1 minute), DC4,200V (1 minute)
- Built-in overcurrent protection circuits (recovers automatically)
- Built-in remote ON/OFF
- Output voltage adjustability by external variable resistor (MHFS3/MHFS6)
- For medical electric equipment (ANSI/AAMI ES60601-1, EN60601-1 3rd)
- Medical Isolation Grade 2MOOP
- High reliability : not built-in aluminum and tantalum electrolytic capacitor

CE marking

- Low voltage Directive
- RoHS Directive

UKCA marking

- Electrical Equipment Safety Regulations
- RoHS Regulations

Safety agency approvals

- UL62368-1, EN62368-1, C-UL (equivalent to CAN/CSA-C22.2 No.62368-1),
- ANSI/AAMI ES60601-1, EN60601-1 3rd, C-UL (equivalent to CAN/CSA-C22.2 No.60601-1)

5-years warranty

MHFS3

MHF S 3 24 05

① ② ③ ④ ⑤

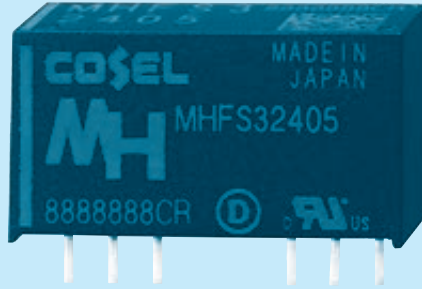
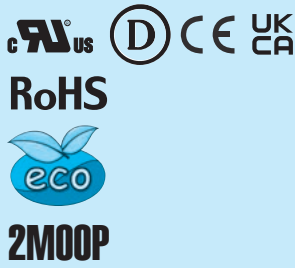

- ① Series name
- ② Single output
- ③ Output wattage
- ④ Input voltage
- ⑤ Output voltage

*If TRM pin does not open, the output voltage can not be adjusted.

MODEL	MHFS3123R3	MHFS31205	MHFS31209	MHFS31212	MHFS31215	MHFS3243R3	MHFS32405	MHFS32409	MHFS32412	MHFS32415
MAX OUTPUT WATTAGE[W]	2.64	3.00	2.97	3.00	3.00	2.64	3.00	2.97	3.00	3.00
DC OUTPUT	VOLTAGE[V]	3.3	5	9	12	15	3.3	5	9	12
	CURRENT[A]	0.8	0.6	0.33	0.25	0.2	0.8	0.6	0.33	0.25

SPECIFICATIONS

MODEL	MHFS3123R3	MHFS31205	MHFS31209	MHFS31212	MHFS31215	MHFS3243R3	MHFS32405	MHFS32409	MHFS32412	MHFS32415	
INPUT	VOLTAGE[VDC]	4.5 - 18 (Surge voltage 25V, 100ms max)					9 - 36 (Surge voltage 50V, 100ms max)				
	CURRENT[A]	*1 0.29typ	0.32typ	0.31typ	0.31typ	0.31typ	0.15typ	0.16typ	0.16typ	0.16typ	0.16typ
	EFFICIENCY[%]	*1 77typ	79typ	81typ	82typ	81.5typ	77.5typ	79typ	81.5typ	82typ	81typ
OUTPUT	VOLTAGE[V]	3.3	5	9	12	15	3.3	5	9	12	15
	CURRENT[A]	0.8	0.6	0.33	0.25	0.2	0.8	0.6	0.33	0.25	0.2
	LINE REGULATION[mV]	20max	20max	40max	48max	60max	20max	20max	40max	48max	60max
	LOAD REGULATION[mV]	20max	20max	40max	48max	60max	20max	20max	40max	48max	60max
	RIPPLE[mVp-p]	*2 120max	120max	150max	150max	150max	120max	120max	150max	150max	150max
	RIPPLE NOISE[mVp-p]	*2 200max	200max	200max	200max	200max	200max	200max	200max	200max	200max
	TEMPERATURE REGULATION[mV]	-20 to +70°C	50max	50max	100max	150max	180max	50max	50max	100max	150max
		-40 to +70°C	80max	80max	160max	240max	290max	80max	80max	160max	240max
	DRIFT[mV]	*3 20max	20max	40max	48max	60max	20max	20max	40max	48max	60max
	START-UP TIME[ms]	30max (Rated input, I _o =100%)									
	OUTPUT VOLTAGE ADJUSTMENT RANGE	Fixed (TRM pin open) Available to adjust by external variable resistor									
OUTPUT VOLTAGE SETTING[V]	3.21 - 3.42	4.90 - 5.21	8.73 - 9.27	11.64 - 12.36	14.55 - 15.45	3.21 - 3.42	4.90 - 5.21	8.73 - 9.27	11.64 - 12.36	14.55 - 15.45	
PROTECTION CIRCUIT AND OTHERS	OVERCURRENT PROTECTION	Works over 105% of rating and recovers automatically									
	REMOTE ON/OFF	Provided (Negative logic L:ON, H:OFF)									

MODEL	MHFS3483R3	MHFS34805	MHFS34809	MHFS34812	MHFS34815	
MAX OUTPUT WATTAGE[W]	2.64	3.00	2.97	3.00	3.00	
DC OUTPUT	VOLTAGE[V]	3.3	5	9	12	15
	CURRENT[A]	0.8	0.6	0.33	0.25	0.2

SPECIFICATIONS

MODEL	MHFS3483R3	MHFS34805	MHFS34809	MHFS34812	MHFS34815	
INPUT	VOLTAGE[VDC]	18 - 76 (Surge voltage 100V, 100ms max)				
	CURRENT[A]	*1 0.072typ	0.080typ	0.076typ	0.076typ	0.077typ
	EFFICIENCY[%]	*1 77typ	79typ	82typ	82.5typ	81.5typ
OUTPUT	VOLTAGE[V]	3.3	5	9	12	15
	CURRENT[A]	0.8	0.6	0.33	0.25	0.2
	LINE REGULATION[mV]	20max	20max	40max	48max	60max
	LOAD REGULATION[mV]	20max	20max	40max	48max	60max
	RIPPLE[mVp-p]	*2 120max	120max	150max	150max	150max
	RIPPLE NOISE[mVp-p]	*2 200max	200max	200max	200max	200max
	TEMPERATURE REGULATION[mV]	-20 to +70°C	50max	50max	100max	150max
		-40 to +70°C	80max	80max	160max	240max
	DRIFT[mV]	*3 20max	20max	40max	48max	60max
	START-UP TIME[ms]	30max (Rated input, I _o =100%)				
	OUTPUT VOLTAGE ADJUSTMENT RANGE	Fixed (TRM pin open) Available to adjust by external variable resistor				
OUTPUT VOLTAGE SETTING[V]	3.21 - 3.42	4.90 - 5.21	8.73 - 9.27	11.64 - 12.36	14.55 - 15.45	
PROTECTION CIRCUIT AND OTHERS	OVERCURRENT PROTECTION	Works over 105% of rating and recovers automatically				
	REMOTE ON/OFF	Provided (Negative logic L:ON, H:OFF)				

GENERAL SPECIFICATIONS

ISOLATION	INPUT-OUTPUT	AC3,000V 1minute Cutoff current=1mA, DC4,200V 1minute Cutoff current=1mA, DC500V 1,000MΩ (20±15°C) 2MOOP (250VAC, 3,000m max)
ISOLATION CAPACITANCE	INPUT-OUTPUT	20pF max
ENVIRONMENT	OPERATING TEMP.,HUMID.AND ALTITUDE	-40 to +85°C, 20 to 95%RH (Non condensing) (Refer to Derating)
	STORAGE TEMP.,HUMID.AND ALTITUDE	-40 to +100°C, 20 to 95%RH (Non condensing)
	VIBRATION	10 - 55Hz 98.0m/s ² (10G), 3minutes period, 60minutes each along X, Y and Z axis
	IMPACT	490.3m/s ² (50G) 11ms, once each along X, Y and Z axis
SAFETY	AGENCY APPROVALS	UL62368-1, EN62368-1, C-UL (equivalent to CAN/CSA-C22.2 No.62368-1), ANSI/AAMI ES60601-1, EN60601-1 3rd, C-UL (equivalent to CAN/CSA-C22.2 No.60601-1)
OTHERS	CASE SIZE/WEIGHT	22.0×12.0×9.5mm [0.87×0.48×0.38 inches] (W×H×D) / 7g max
	COOLING METHOD	Convection/Forced air

- *1 Rated input 12V, 24V or 48V DC Io=100%
- *2 Ripple and ripple noise is measured by using test board with ceramic capacitor 0.1μF at 50mm from output pins.
- *3 Drift is the DC output accuracy for eight hours period after a half-hour warm-up at 25°C.
- * Parallel operation is not possible.
- * MHFW3xx12/MHFW3xx15 is available as single output, +24V/+30V

External view

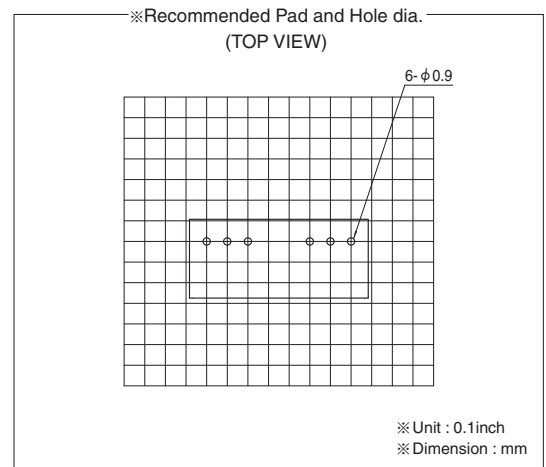
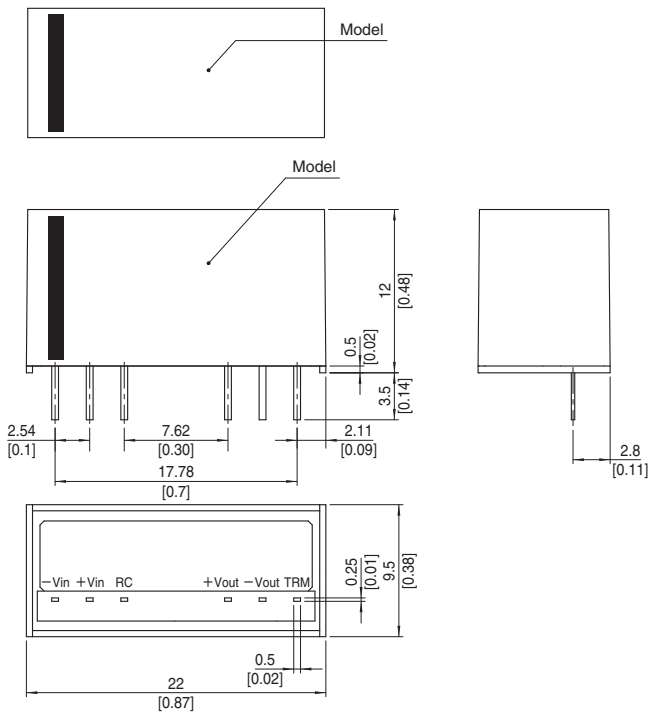

- ※ Tolerance ±0.5 [±0.02]
- ※ Dimensions in mm, []= inches
- ※ Pin terminal material : Copper
- ※ Planting treatment of terminal : Lead free plating
- ※ Case material : PBT
- ※ Weight 7g max

MHFW3

MHF W 3 24 12

① ② ③ ④ ⑤



RoHS



2MOOP

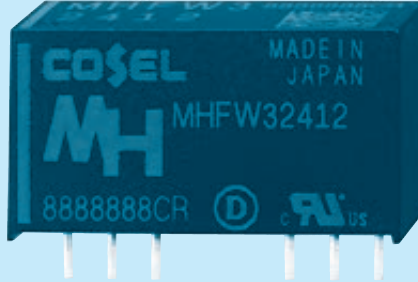

- ① Series name
- ② Dual output
- ③ Output wattage
- ④ Input voltage
- ⑤ Output voltage

MODEL	MHFW31212	MHFW31215	MHFW32412	MHFW32415	MHFW34812	MHFW34815	
MAX OUTPUT WATTAGE[W]	3.12	3.00	3.12	3.00	3.12	3.00	
DC OUTPUT	VOLTAGE[V] *1	±12 or +24	±15 or +30	±12 or +24	±15 or +30	±12 or +24	±15 or +30
	CURRENT[A]	0.13	0.1	0.13	0.1	0.13	0.1

SPECIFICATIONS

	MODEL	MHFW31212	MHFW31215	MHFW32412	MHFW32415	MHFW34812	MHFW34815	
INPUT	VOLTAGE[VDC]	4.5 - 18 (Surge voltage 25V, 100ms max)		9 - 36 (Surge voltage 50V, 100ms max)		18 - 76 (Surge voltage 100V, 100ms max)		
	CURRENT[A] *2	0.32typ	0.31typ	0.16typ	0.16typ	0.081typ	0.079typ	
	EFFICIENCY[%] *2	80.5typ	80typ	80typ	79typ	81typ	80typ	
OUTPUT	VOLTAGE[V]	±12 (+24)	±15 (+30)	±12 (+24)	±15 (+30)	±12 (+24)	±15 (+30)	
	CURRENT[A]	0.13	0.1	0.13	0.1	0.13	0.1	
	LINE REGULATION[mV]	60max	75max	60max	75max	60max	75max	
	CROSS REGULATION[mV]	*3	480max	600max	480max	600max	480max	600max
		*4	600max	750max	600max	750max	600max	750max
	RIPPLE[mVp-p] *5	180max	180max	180max	180max	180max	180max	
	RIPPLE NOISE[mVp-p] *5	210max	210max	210max	210max	210max	210max	
	TEMPERATURE REGULATION[mV]	-20 to +70°C	180max	220max	180max	220max	180max	220max
		-40 to +70°C	290max	340max	290max	340max	290max	340max
	DRIFT[mV] *6	48max	60max	48max	60max	48max	60max	
START-UP TIME[ms]	30max (Rated input, I _o =100%)							
OUTPUT VOLTAGE SETTING[V]	11.64 - 12.36	14.55 - 15.45	11.64 - 12.36	14.55 - 15.45	11.64 - 12.36	14.55 - 15.45		
PROTECTION CIRCUIT AND OTHERS	OVERCURRENT PROTECTION	Works over 105% of rating and recovers automatically						
	REMOTE ON/OFF	Provided (Negative logic L:ON, H:OFF)						

GENERAL SPECIFICATIONS

ISOLATION	INPUT-OUTPUT	AC3,000V 1minute Cutoff current=1mA, DC4,200V 1minute Cutoff current=1mA, DC500V 1,000MΩ (20±15°C) 2MOOP (250VAC, 3,000m max)
ISOLATION CAPACITANCE	INPUT-OUTPUT	20pF max
ENVIRONMENT	OPERATING TEMP., HUMID. AND ALTITUDE	-40 to +85°C, 20 to 95%RH (Non condensing) (Refer to Derating)
	STORAGE TEMP., HUMID. AND ALTITUDE	-40 to +100°C, 20 to 95%RH (Non condensing)
	VIBRATION	10 - 55Hz 98.0m/s ² (10G), 3minutes period, 60minutes each along X, Y and Z axis
	IMPACT	490.3m/s ² (50G) 11ms, once each along X, Y and Z axis
SAFETY	AGENCY APPROVALS	UL62368-1, EN62368-1, C-UL (equivalent to CAN/CSA-C22.2 No.62368-1), ANSI/AAMI ES60601-1, EN60601-1 3rd, C-UL (equivalent to CAN/CSA-C22.2 No.60601-1)
OTHERS	CASE SIZE/WEIGHT	22.0×12.0×9.5mm [0.87×0.48×0.38 inches] (W×H×D) / 7g max
	COOLING METHOD	Convection/Forced air

- *1 Single output +24V, +30V with no use of COM.
- *2 Rated input 12V or 24V or 48V DC Io=100%
- *3 Symmetrical loading from 20% to 100%.
- *4 Symmetrical loading from 0% to 100%.
- *5 Ripple and ripple noise is measured by using test board with ceramic capacitor 0.1μF at 50mm from output pins.
- *6 Drift is the DC output accuracy for eight hours period after a half-hour warm-up at 25°C.
- * Parallel operation is not possible.

External view

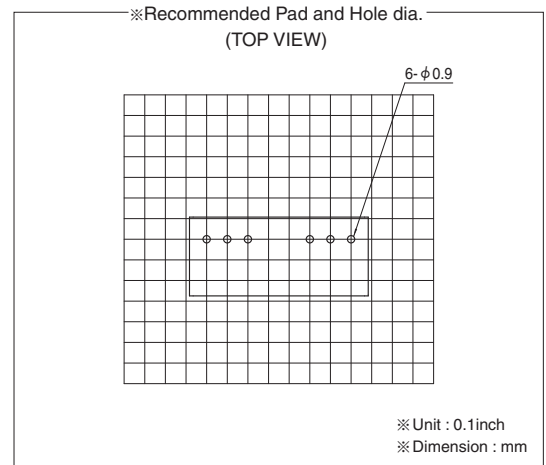
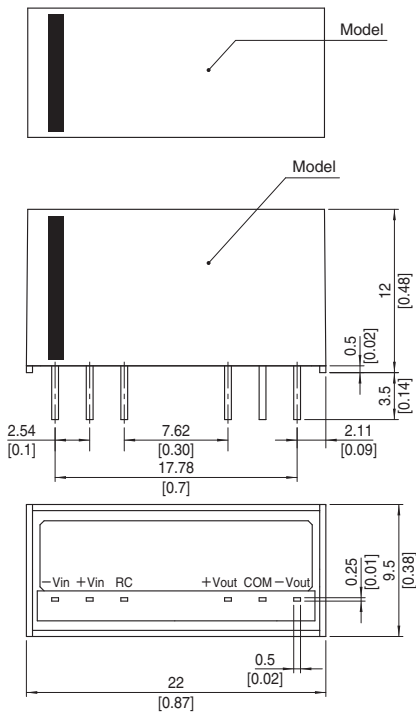

- ※ Tolerance ±0.5 [±0.02]
- ※ Dimensions in mm, []= inches
- ※ Pin terminal material : Copper
- ※ Planting treatment of terminal : Lead free plating
- ※ Case material : PBT
- ※ Weight 7g max

MHFS6

MHF S 6 24 05

① ② ③ ④ ⑤

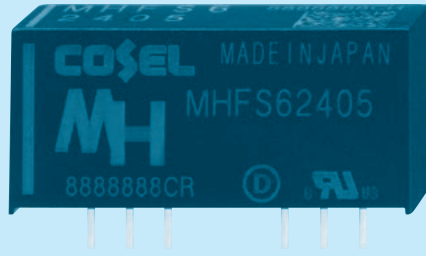
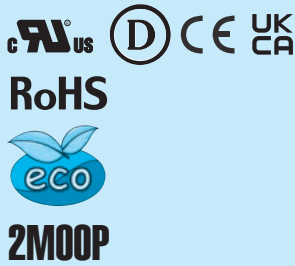

- ① Series name
- ② Single output
- ③ Output wattage
- ④ Input voltage
- ⑤ Output voltage

*If TRM pin does not open, the output voltage can not be adjusted.

MODEL	MHFS6123R3	MHFS61205	MHFS61209	MHFS61212	MHFS61215	MHFS6243R3	MHFS62405	MHFS62409	MHFS62412	MHFS62415
MAX OUTPUT WATTAGE[W]	5.28	6.00	5.94	6.00	6.00	5.28	6.00	5.94	6.00	6.00
DC OUTPUT	VOLTAGE[V]	3.3	5	9	12	15	3.3	5	9	12
	CURRENT[A]	1.6	1.2	0.66	0.5	0.4	1.6	1.2	0.66	0.5

SPECIFICATIONS

	MODEL	MHFS6123R3	MHFS61205	MHFS61209	MHFS61212	MHFS61215	MHFS6243R3	MHFS62405	MHFS62409	MHFS62412	MHFS62415	
INPUT	VOLTAGE[VDC]	4.5 - 18 (Surge voltage 25V, 100ms max) (Refer to Derating for 5V and below)					9 - 36 (Surge voltage 50V, 100ms max) (Refer to Derating for 12V and below)					
	CURRENT[A]	*1 0.57typ	0.61typ	0.59typ	0.60typ	0.60typ	0.28typ	0.31typ	0.30typ	0.30typ	0.31typ	
	EFFICIENCY[%]	*1 78typ	82typ	84typ	84typ	84typ	79typ	83typ	84typ	84typ	83typ	
OUTPUT	VOLTAGE[V]	3.3	5	9	12	15	3.3	5	9	12	15	
	CURRENT[A]	1.6	1.2	0.66	0.5	0.4	1.6	1.2	0.66	0.5	0.4	
	LINE REGULATION[mV]	20max	20max	40max	48max	60max	20max	20max	40max	48max	60max	
	LOAD REGULATION[mV]	20max	20max	40max	48max	60max	20max	20max	40max	48max	60max	
	RIPPLE[mVp-p]	*3	75max	75max	100max	100max	100max	75max	75max	100max	100max	100max
		*2 *4	225max	225max	300max	300max	300max	225max	225max	300max	300max	300max
	RIPPLE NOISE[mVp-p]	*3	120max	120max	150max	150max	150max	120max	120max	150max	150max	150max
		*2 *4	300max	300max	400max	400max	400max	300max	300max	400max	400max	400max
	TEMPERATURE REGULATION[mV]	-20 to +50°C	50max	50max	100max	150max	180max	50max	50max	100max	150max	180max
		-40 to +50°C	80max	80max	160max	240max	290max	80max	80max	160max	240max	290max
DRIFT[mV]	*5	20max	20max	40max	48max	60max	20max	20max	40max	48max	60max	
START-UP TIME[ms]		30max (Rated input, I _o =100%)										
OUTPUT VOLTAGE ADJUSTMENT RANGE		Fixed (TRM pin open) Available to adjust by external variable resistor										
		-5%/+10%	-5%/+20%	-5%/+20%	-5%/+20%	-5%/+20%	-5%/+10%	-5%/+20%	-5%/+20%	-5%/+20%	-5%/+20%	
OUTPUT VOLTAGE SETTING[V]		3.21 - 3.42	4.90 - 5.21	8.73 - 9.27	11.64 - 12.36	14.55 - 15.45	3.21 - 3.42	4.90 - 5.21	8.73 - 9.27	11.64 - 12.36	14.55 - 15.45	
PROTECTION CIRCUIT AND OTHERS	OVERCURRENT PROTECTION	Works over 105% of rating and recovers automatically										
	REMOTE ON/OFF	Provided (Negative logic L:ON, H:OFF)										

MODEL	MHFS6483R3	MHFS64805	MHFS64809	MHFS64812	MHFS64815	
MAX OUTPUT WATTAGE[W]	5.28	6.00	5.94	6.00	6.00	
DC OUTPUT	VOLTAGE[V]	3.3	5	9	12	15
	CURRENT[A]	1.6	1.2	0.66	0.5	0.4

SPECIFICATIONS

	MODEL	MHFS6483R3	MHFS64805	MHFS64809	MHFS64812	MHFS64815	
INPUT	VOLTAGE[VDC]	18 - 76 (Surge voltage 100V, 100ms max) (Refer to Derating for 24V and below)					
	CURRENT[A]	*1 0.142typ	0.153typ	0.148typ	0.149typ	0.149typ	
	EFFICIENCY[%]	*1 78typ	82typ	84typ	84typ	84typ	
OUTPUT	VOLTAGE[V]	3.3	5	9	12	15	
	CURRENT[A]	1.6	1.2	0.66	0.5	0.4	
	LINE REGULATION[mV]	20max	20max	40max	48max	60max	
	LOAD REGULATION[mV]	20max	20max	40max	48max	60max	
	RIPPLE[mVp-p]	*3	75max	75max	100max	100max	100max
		*2 *4	225max	225max	300max	300max	300max
	RIPPLE NOISE[mVp-p]	*3	120max	120max	150max	150max	150max
		*2 *4	300max	300max	400max	400max	400max
	TEMPERATURE REGULATION[mV]	-20 to +50°C	50max	50max	100max	150max	180max
		-40 to +50°C	80max	80max	160max	240max	290max
DRIFT[mV]	*5	20max	20max	40max	48max	60max	
START-UP TIME[ms]		30max (Rated input, I _o =100%)					
OUTPUT VOLTAGE ADJUSTMENT RANGE		Fixed (TRM pin open) Available to adjust by external variable resistor					
		-5%/+10%	-5%/+20%	-5%/+20%	-5%/+20%	-5%/+20%	
OUTPUT VOLTAGE SETTING[V]		3.21 - 3.42	4.90 - 5.21	8.73 - 9.27	11.64 - 12.36	14.55 - 15.45	
PROTECTION CIRCUIT AND OTHERS	OVERCURRENT PROTECTION	Works over 105% of rating and recovers automatically					
	REMOTE ON/OFF	Provided (Negative logic L:ON, H:OFF)					

GENERAL SPECIFICATIONS

ISOLATION	INPUT-OUTPUT	AC3,000V 1minute Cutoff current=1mA, DC4,200V 1minute Cutoff current=1mA, DC500V 1,000MΩ (20±15°C) 2MOOP (250VAC, 3,000m max)
ISOLATION CAPACITANCE	INPUT-OUTPUT	20pF max
ENVIRONMENT	OPERATING TEMP., HUMID. AND ALTITUDE	-40 to +85°C, 20 to 95%RH (Non condensing) (Refer to Derating)
	STORAGE TEMP., HUMID. AND ALTITUDE	-40 to +100°C, 20 to 95%RH (Non condensing)
	VIBRATION	10 - 55Hz 98.0m/s ² (10G), 3minutes period, 60minutes each along X, Y and Z axis
	IMPACT	490.3m/s ² (50G) 11ms, once each along X, Y and Z axis
SAFETY	AGENCY APPROVALS	UL62368-1, EN62368-1, C-UL (equivalent to CAN/CSA-C22.2 No.62368-1), ANSI/AAMI ES60601-1, EN60601-1 3rd, C-UL (equivalent to CAN/CSA-C22.2 No.60601-1)
OTHERS	CASE SIZE/WEIGHT	26.0×12.0×9.5mm [1.03×0.48×0.38 inches] (W×H×D) / 8g max
	COOLING METHOD	Convection/Forced air

- *1 Rated input 12V, 24V or 48V DC I_o=100%
- *2 Ripple and ripple noise is measured by using test board with ceramic capacitor 0.1μF at 50mm from output pins.
- *3 At Vin=4.5 - 16V (MHFS612xx), Vin=9 - 30V (MHFS624xx), Vin=18 - 60V (MHFS648xx) / I_o=30 - 100%.
- *4 At Vin=4.5 - 16V (MHFS612xx), Vin=9 - 30V (MHFS624xx), Vin=18 - 60V (MHFS648xx) / I_o=0 - 30%.
- At Vin=16 - 18V (MHFS612xx), Vin=30 - 36V (MHFS624xx), Vin=60 - 76V (MHFS648xx) / I_o=0 - 100%.
- *5 Drift is the DC output accuracy for eight hours period after a half-hour warm-up at 25°C.
- * Parallel operation is not possible.
- * MHFW6xx12/MHFW6xx15 is available as single output, +24V/+30V.

External view

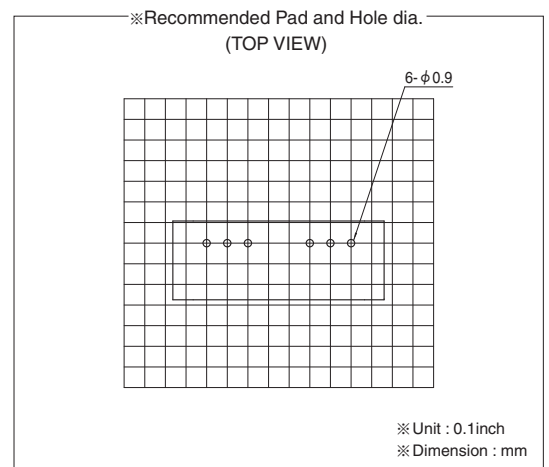
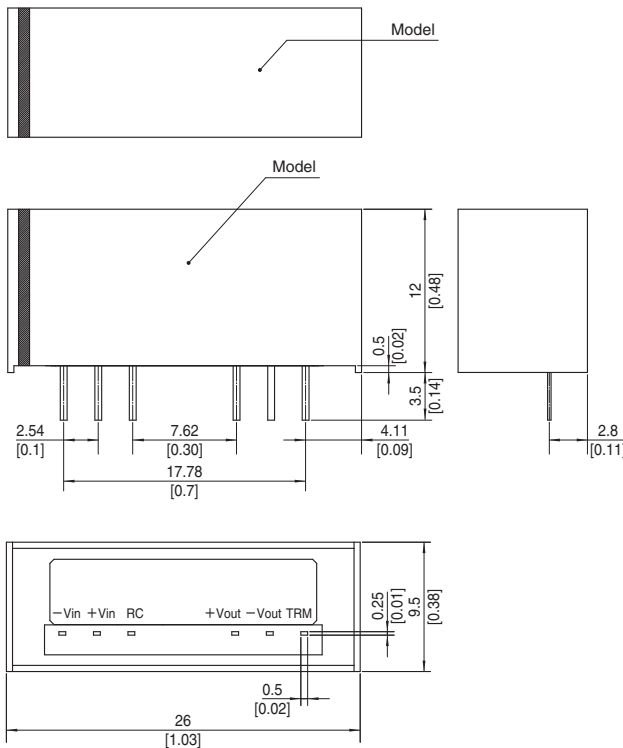

- ※ Tolerance ±0.5 [±0.02]
- ※ Dimensions in mm, []= inches
- ※ Pin terminal material : Copper
- ※ Plating treatment of terminal : Lead free plating
- ※ Case material : PBT
- ※ Weight 8g max

MH

MHFW6

MHF W 6 24 12

① ② ③ ④ ⑤



RoHS



2MOOP

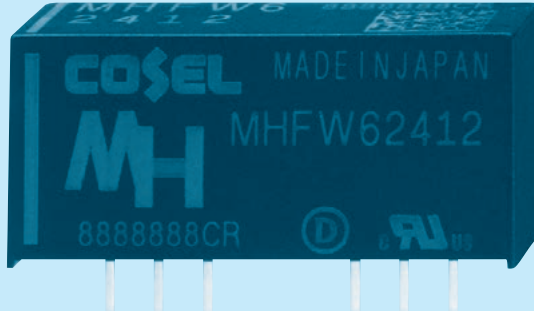

- ① Series name
- ② Dual output
- ③ Output wattage
- ④ Input voltage
- ⑤ Output voltage

MODEL	MHFW61212	MHFW61215	MHFW62412	MHFW62415	MHFW64812	MHFW64815	
MAX OUTPUT WATTAGE[W]	6.00	6.00	6.00	6.00	6.00	6.00	
DC OUTPUT	VOLTAGE[V] *1	±12 or +24	±15 or +30	±12 or +24	±15 or +30	±12 or +24	±15 or +30
	CURRENT[A]	0.25	0.2	0.25	0.2	0.25	0.2

SPECIFICATIONS

	MODEL	MHFW61212	MHFW61215	MHFW62412	MHFW62415	MHFW64812	MHFW64815	
INPUT	VOLTAGE[VDC]	4.5 - 18 (Surge voltage 25V, 100ms max) (Refer to Derating for 5V and below)		9 - 36 (Surge voltage 50V, 100ms max) (Refer to Derating for 12V and below)		18 - 76 (Surge voltage 100V, 100ms max) (Refer to Derating for 24V and below)		
	CURRENT[A] *2	0.60typ	0.60typ	0.30typ	0.30typ	0.149typ	0.151typ	
	EFFICIENCY[%] *2	84typ	84typ	84typ	84typ	84typ	83typ	
OUTPUT	VOLTAGE[V]	±12 (+24)		±12 (+24)		±12 (+24)		
	CURRENT[A]	0.25		0.25		0.25		
	LINE REGULATION[mV]	60max		60max		60max		
	CROSS REGULATION[mV]	*3	480max		480max		480max	
		*4	600max		600max		600max	
	RIPPLE[mVp-p]	*6	120max		120max		120max	
		*7	360max		360max		360max	
	RIPPLE NOISE[mVp-p]	*6	200max		200max		200max	
		*7	500max		500max		500max	
	TEMPERATURE REGULATION[mV]	-20 to +50°C	180max		180max		180max	
		-40 to +50°C	290max		290max		290max	
DRIFT[mV] *8	48max		48max		48max			
START-UP TIME[ms]	30max (Rated input, Io=100%)							
OUTPUT VOLTAGE SETTING[V]	11.64 - 12.36		14.55 - 15.45		11.64 - 12.36		14.55 - 15.45	
PROTECTION CIRCUIT AND OTHERS	OVERCURRENT PROTECTION	Works over 105% of rating and recovers automatically						
	REMOTE ON/OFF	Provided (Negative logic L:ON, H:OFF)						

GENERAL SPECIFICATIONS

ISOLATION	INPUT-OUTPUT	AC3,000V 1minute Cutoff current=1mA, DC4,200V 1minute Cutoff current=1mA, DC500V 1,000MΩ (20±15°C) 2MOOP (250VAC, 3,000m max)
ISOLATION CAPACITANCE	INPUT-OUTPUT	20pF max
ENVIRONMENT	OPERATING TEMP., HUMID. AND ALTITUDE	-40 to +85°C, 20 to 95%RH (Non condensing) (Refer to Derating)
	STORAGE TEMP., HUMID. AND ALTITUDE	-40 to +100°C, 20 to 95%RH (Non condensing)
	VIBRATION	10 - 55Hz 98.0m/s ² (10G), 3minutes period, 60minutes each along X, Y and Z axis
	IMPACT	490.3m/s ² (50G) 11ms, once each along X, Y and Z axis
SAFETY	AGENCY APPROVALS	UL62368-1, EN62368-1, C-UL (equivalent to CAN/CSA-C22.2 No.62368-1), ANSI/AAMI ES60601-1, EN60601-1 3rd, C-UL (equivalent to CAN/CSA-C22.2 No.60601-1)
OTHERS	CASE SIZE/WEIGHT	26.0×12.0×9.5mm [1.03×0.48×0.38 inches] (W×H×D) / 8g max
	COOLING METHOD	Convection/Forced air

- *1 Single output +24V, +30V with no use of COM.
- *2 Rated input 12V, 24V or 48V DC I_o=100%.
- *3 Symmetrical loading from 20% to 100%.
- *4 Symmetrical loading from 0% to 100%.
- *5 Ripple and ripple noise is measured by using test board with ceramic 0.1μF at 50mm from output pins. P_o is total output power.
- *6 At Vin=4.5 - 16V (MHFW612xx), Vin=9 - 30V (MHFW624xx), Vin=18 - 60V (MHFW648xx) / P_o=30 - 100%.
- *7 At Vin=4.5 - 16V (MHFW612xx), Vin=9 - 30V (MHFW624xx), Vin=18 - 60V (MHFW648xx) / P_o=0 - 30%.
At Vin=16 - 18V (MHFW612xx), Vin=30 - 36V (MHFW624xx), Vin=60 - 76V (MHFW648xx) / P_o=0 - 100%.
- *8 Drift is the DC output accuracy for eight hours period after a half-hour warm-up at 25°C.
- * Parallel operation is not possible.

External view

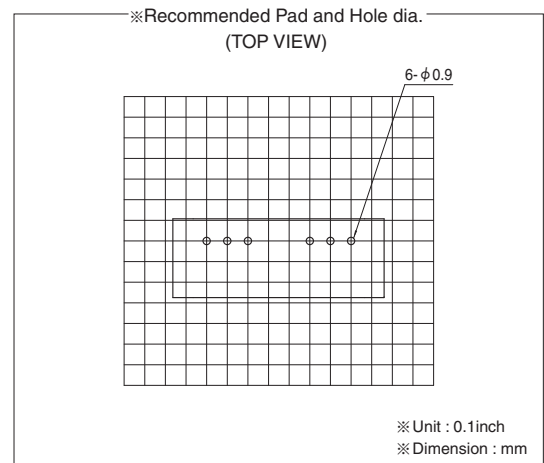
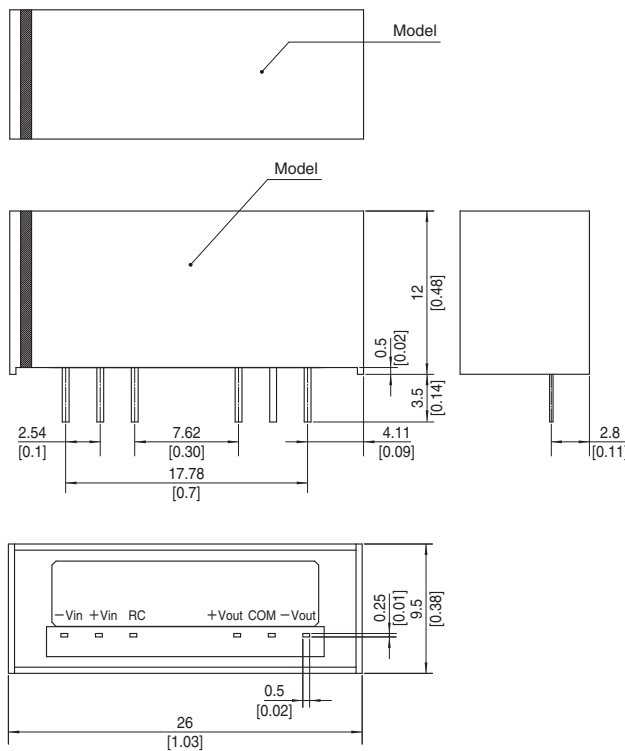

- ※ Tolerance ±0.5 [±0.02]
- ※ Dimensions in mm, []= inches
- ※ Pin terminal material : Copper
- ※ Plating treatment of terminal : Lead free plating
- ※ Case material : PBT
- ※ Weight 8g max

Pin Connection

●MH3/MH6 Single Output, Dual output

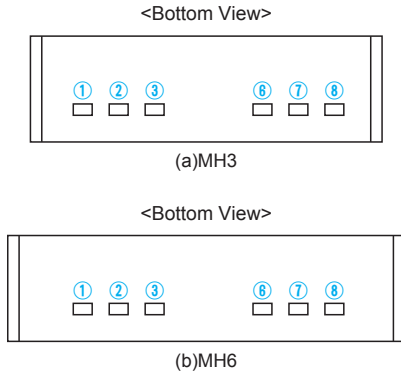

Pin No.	Pin Name	Function
①	-Vin	-DC Input
②	+Vin	+DC Input
③	RC	Remote ON/OFF
⑥	+Vout	+DC Output
⑦	-Vout	-DC Output (for Single Output)
	COM	GND of Output Voltage (for Dual Output)
⑧	TRM	Output Voltage Adjustment (for Single Output)
	-Vout	-DC Output (for Dual Output)

Assembling and Installation Method

Installation

- When two or more power supplies are used side by side, position them with proper intervals to allow enough air ventilation. Ambient temperature around each power supply should not exceed the temperature range shown in “Derating”.
- Avoid placing the DC input line pattern layout underneath the unit. It will increase the line conducted noise. Make sure to leave an ample distance between the line pattern layout and the unit. Also avoid placing the DC output line pattern underneath the unit because it may increase the output noise. Lay out the pattern away from the unit.
- Avoid placing the signal line pattern layout underneath the unit because the power supply might become unstable. Lay out the pattern away from the unit.
- If insulation is required, design the board considering the distance required for insulation between the input and output.
- Avoid pattern wiring in the shaded area, because the surface of the mounting board on which the power supply is mounted may cause insulation failure between input and output.

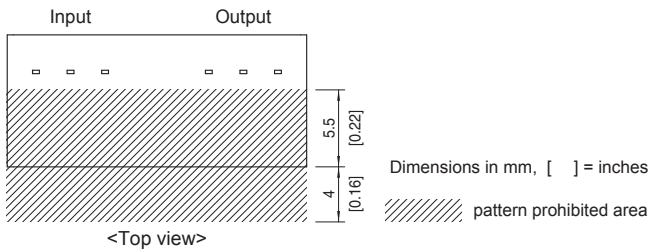

Soldering Conditions

- (1) Flow Soldering : 260°C 15 seconds or less
- (2) Soldering Iron : maximum 360°C 5 seconds or less

Stress to Pin

- Applying excessive stress to the input or output pins of the unit may damage internal connections. Avoid applying stress in excess of that shown in right figure.
- Input/output pins are soldered to the PCB internally. Do not pull or bend a lead powerfully.

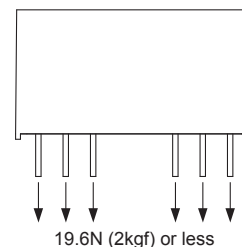

- If it is expected that stress is applied to the input/output pins due to vibration or impact, reduce the stress to the pin by taking such measures as fixing the unit to the PCB by silicone rubber, etc.
- Due to prevent failure, unit should not be pulled after soldering with PCB.

Derating

Derating curve for input voltage

MH6

MHFS6, MHFW6 has derating by input voltage is required. shown below.

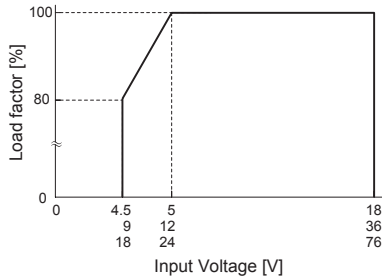

Ambient temperature derating curve

It is necessary to note thermal fatigue life by power cycle. Please reduce the temperature fluctuation range as much as possible when the up and down of temperature are frequently generated.

In case of forced air, ventilation must keep the temperature of point below the temperatures shown in Instruction Manual 7.

Model name

The following letters / numbers are entered in □.

ex.) . . . MHF□312□

S, W / 3R3, 05, 09, 12, 15

MH3 (Rated Input Voltage)

(1) In the case of Convection Cooling (Reference)

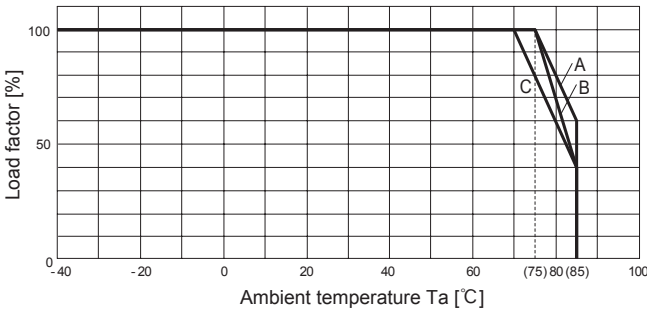

Output Voltage Model name	3.3	5	9	12	15	±12	±15
MHF□312□	B	B	A	A	A	C	C
MHF□324□	A	B	B	B	B	C	C
MHF□348□	A	B	A	A	B	C	C

(2) In the case of Forced Air Cooling (1.0m/s) (Reference)

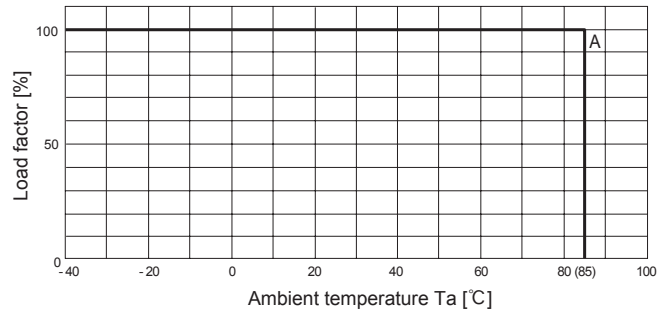

Output Voltage Model name	3.3	5	9	12	15	±12	±15
MHF□312□	A	A	A	A	A	A	A
MHF□324□	A	A	A	A	A	A	A
MHF□348□	A	A	A	A	A	A	A

MH6 (Rated Input Voltage)

In the hatched area, the specification of Ripple Noise is different from other area.

(1) In the case of Convection Cooling (Reference)

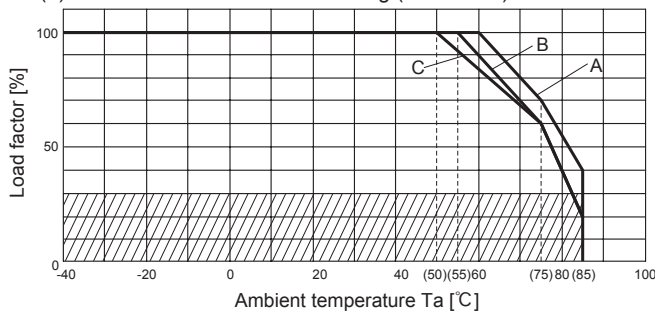

Output Voltage Model name	3.3	5	9	12	15	±12	±15
MHF□612□	C	C	B	B	B	B	B
MHF□624□	C	C	B	B	B	B	B
MHF□648□	B	B	A	A	A	A	A

(2) In the case of Forced Air Cooling (1.0m/s) (Reference)

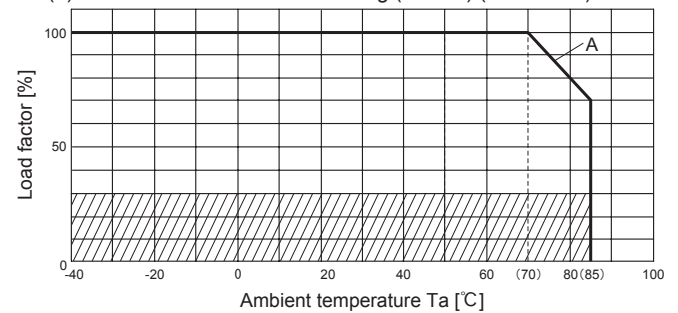

Output Voltage Model name	3.3	5	9	12	15	±12	±15
MHF□612□	A	A	A	A	A	A	A
MHF□624□	A	A	A	A	A	A	A
MHF□648□	A	A	A	A	A	A	A

Instruction Manual

◆ It is necessary to read the "Instruction Manual" and "Before using our product" before you use our product.

- Instruction Manual <https://www.cosel.co.jp/redirect/catalog/en/MHFS/>
- Instruction Manual <https://www.cosel.co.jp/redirect/catalog/en/MHFW/>
- Before using our product <https://en.cosel.co.jp/technical/caution/index.html>

MHFS



MHFW



NOTICE



Basic Characteristics Data

Model	Circuit method	Switching frequency [kHz] (reference)	Input current [A]	Inrush current protection	PCB/Pattern			Series/Redundancy operation availability	
					Material	Single sided	Double sided	Series operation	Redundancy operation
MH3	Flyback converter	200-1500 *3	*1	-	glass fabric base,epoxy resin		Yes	Yes	*2
MH6	Flyback converter	150-1400 *3	*1	-	glass fabric base,epoxy resin		Yes	Yes	*2

*1 Refer to Specification.

*2 Refer to Instruction Manual.

*3 The value changes depending on input and load.



Low Profile



Isolated



OCP



Safety Approvals

SUS, SUW-series / SUCS, SUCW-series / SUTS, SUTW-series

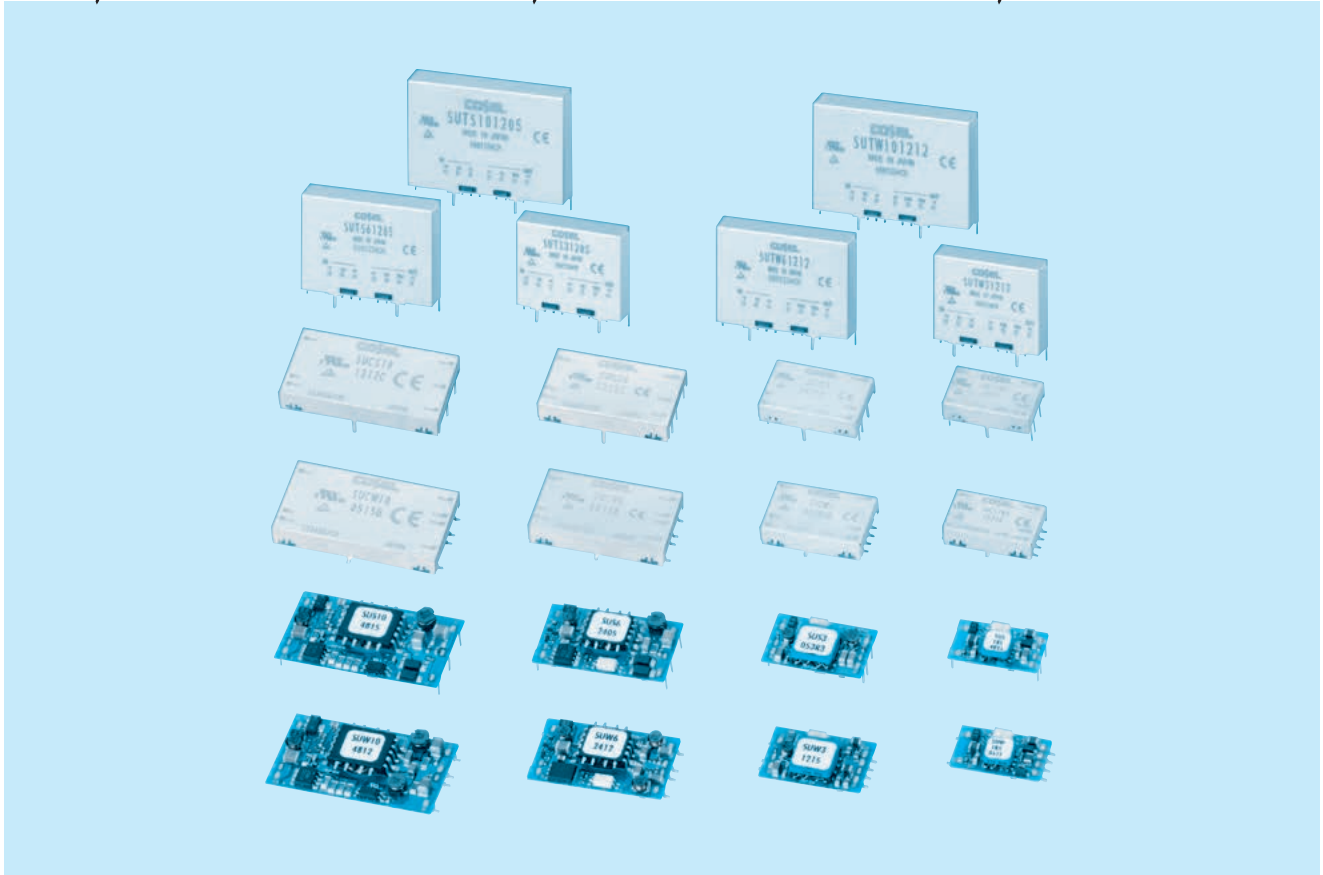

SU·SUC·SUT

■ Feature

- SMD mounting type and through-hole mounting type
- High efficiency (synchronous rectifier circuit)
- Built-in overcurrent protection circuits
- Built-in remote ON/OFF (SU / SUC / SUT 3-10)
- High reliability : not built-in aluminum and tantalum electrolytic capacitor

■ CE marking

- Low Voltage Directive
- RoHS Directive

■ UKCA marking

- Electrical Equipment Safety Regulations
- RoHS Regulations

■ Safety agency approvals

- UL60950-1, C-UL, EN62368-1

■ 5-year warranty

SUS1R5

SU S 1R5 12 05 B P

① ② ③ ④ ⑤ ⑥ ⑦



RoHS

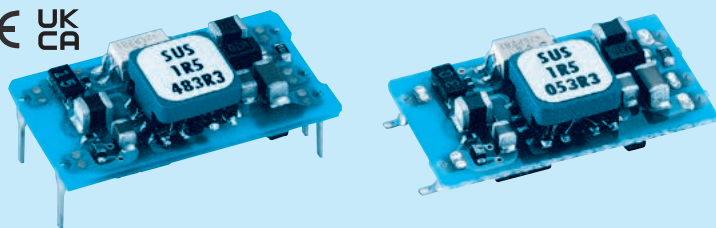

- ① Series name
- ② Single output
- ③ Output wattage
- ④ Input voltage
- ⑤ Output voltage
- ⑥ Mounting type
B : SMD
C : DIP
- ⑦ Packing form
Blank: Plastic cover
P : Tray (SMD type)

MODEL	SUS1R5053R3	SUS1R50505	SUS1R50512	SUS1R50515	SUS1R5123R3	SUS1R51205	SUS1R51212	SUS1R51215	
MAX OUTPUT WATTAGE[W]	1.32	1.5	1.56	1.5	1.32	1.5	1.56	1.5	
DC OUTPUT	VOLTAGE[V] *1	3.3	5	12	15	3.3	5	12	15
	CURRENT[A]	0.4	0.3	0.13	0.1	0.4	0.3	0.13	0.1

SPECIFICATIONS

	MODEL	SUS1R5053R3	SUS1R50505	SUS1R50512	SUS1R50515	SUS1R5123R3	SUS1R51205	SUS1R51212	SUS1R51215	
INPUT	VOLTAGE[V]	DC4.5 - 9				DC9 - 18				
	CURRENT[A] *2	0.377typ	0.405typ	0.422typ	0.405typ	0.153typ	0.164typ	0.171typ	0.164typ	
	EFFICIENCY[%] *2	70typ	74typ	74typ	74typ	72typ	76typ	76typ	76typ	
OUTPUT	VOLTAGE[V]	3.3	5	12	15	3.3	5	12	15	
	CURRENT[A]	0.4	0.3	0.13	0.1	0.4	0.3	0.13	0.1	
	LINE REGULATION[mV]	20max	20max	48max	60max	20max	20max	48max	60max	
	LOAD REGULATION[mV]	40max	40max	100max	120max	40max	40max	100max	120max	
	RIPPLE[mVp-p]	-20 to +55°C *3	80max	80max	120max	120max	80max	80max	120max	120max
		-40 to -20°C *3	120max	120max	150max	150max	120max	120max	150max	150max
	RIPPLE NOISE[mVp-p]	-20 to +55°C *3	120max	120max	150max	150max	120max	120max	150max	150max
		-40 to -20°C *3	200max	200max	200max	200max	200max	200max	200max	200max
	TEMPERATURE REGULATION[mV]	-20 to +55°C	50max	50max	150max	180max	50max	50max	150max	180max
		-40 to +55°C	80max	80max	240max	290max	80max	80max	240max	290max
DRIFT[mV] *4	20max	20max	48max	60max	20max	20max	48max	60max		
START-UP TIME[ms]	20max (Minimum input, Io=100%)									
OUTPUT VOLTAGE ADJUSTMENT RANGE	Fixed (TRM pin open) ±5% adjustable by external VR									
OUTPUT VOLTAGE SETTING[V] (±3%)	3.21 - 3.42	4.90 - 5.21	11.64 - 12.36	14.55 - 15.45	3.21 - 3.42	4.90 - 5.21	11.64 - 12.36	14.55 - 15.45		
OVERCURRENT PROTECTION	Works over 105% of rating and recovers automatically									

PROTECTION CIRCUIT AND OTHERS

MODEL	SUS1R5243R3	SUS1R52405	SUS1R52412	SUS1R52415	SUS1R5483R3	SUS1R54805	SUS1R54812	SUS1R54815	
MAX OUTPUT WATTAGE[W]	1.32	1.5	1.56	1.5	1.32	1.5	1.56	1.5	
DC OUTPUT	VOLTAGE[V] *1	3.3	5	12	15	3.3	5	12	15
	CURRENT[A]	0.4	0.3	0.13	0.1	0.4	0.3	0.13	0.1

SPECIFICATIONS

	MODEL	SUS1R5243R3	SUS1R52405	SUS1R52412	SUS1R52415	SUS1R5483R3	SUS1R54805	SUS1R54812	SUS1R54815	
INPUT	VOLTAGE[V]	DC18 - 36				DC36 - 76				
	CURRENT[A] *2	0.076typ	0.082typ	0.084typ	0.081typ	0.038typ	0.041typ	0.042typ	0.041typ	
	EFFICIENCY[%] *2	72typ	76typ	77typ	77typ	72typ	76typ	77typ	77typ	
OUTPUT	VOLTAGE[V]	3.3	5	12	15	3.3	5	12	15	
	CURRENT[A]	0.4	0.3	0.13	0.1	0.4	0.3	0.13	0.1	
	LINE REGULATION[mV]	20max	20max	48max	60max	20max	20max	48max	60max	
	LOAD REGULATION[mV]	40max	40max	100max	120max	40max	40max	100max	120max	
	RIPPLE[mVp-p]	-20 to +55°C *3	80max	80max	120max	120max	80max	80max	120max	120max
		-40 to -20°C *3	120max	120max	150max	150max	120max	120max	150max	150max
	RIPPLE NOISE[mVp-p]	-20 to +55°C *3	120max	120max	150max	150max	120max	120max	150max	150max
		-40 to -20°C *3	200max	200max	200max	200max	200max	200max	200max	200max
	TEMPERATURE REGULATION[mV]	-20 to +55°C	50max	50max	150max	180max	50max	50max	150max	180max
		-40 to +55°C	80max	80max	240max	290max	80max	80max	240max	290max
DRIFT[mV] *4	20max	20max	48max	60max	20max	20max	48max	60max		
START-UP TIME[ms]	20max (Minimum input, Io=100%)									
OUTPUT VOLTAGE ADJUSTMENT RANGE	Fixed (TRM pin open) ±5% adjustable by external VR									
OUTPUT VOLTAGE SETTING[V] (±3%)	3.21 - 3.42	4.90 - 5.21	11.64 - 12.36	14.55 - 15.45	3.21 - 3.42	4.90 - 5.21	11.64 - 12.36	14.55 - 15.45		
OVERCURRENT PROTECTION	Works over 105% of rating and recovers automatically									

PROTECTION CIRCUIT AND OTHERS

GENERAL SPECIFICATIONS

ISOLATION	INPUT-OUTPUT	AC500V 1minute, Cutoff current = 10mA, DC500V 50MΩ min (20±15°C)
ENVIRONMENT	OPERATING TEMP.,HUMID.AND ALTITUDE	-40 to +85°C, 20 - 95%RH (Non condensing) (Refer to "Derating"), 3,000m (10,000feet) max
	STORAGE TEMP.,HUMID.AND ALTITUDE	-40 to +100°C, 20 - 95%RH (Non condensing), 9,000m (30,000feet) max
	VIBRATION	10 - 55Hz, 98.0m/s ² (10G), 3minutes period, 60minutes each along X, Y and Z axis
	IMPACT	490.3m/s ² (50G), 11ms, once each along X, Y and Z axis
SAFETY	AGENCY APPROVALS	UL60950-1, C-UL, EN62368-1
OTHERS	CASE SIZE/WEIGHT	21.4 X 6.5 X 12.2mm [0.84 X 0.26 X 0.48 inches] (W X H X D) / 2g max
	COOLING METHOD	Convection/Forced air

- *1 SUW1R5x12/SUW1R5x15 is available as single output, +24V/+30V.
- *2 Rated input 5V, 12V, 24V or 48V DC I_o=100%
- *3 Ripple and Ripple Noise is measured by using measuring board with capacitor with in 25mm from output pin terminals.
- *4 Drift is the change in DC output for an eight hour period after a half-hour warm-up at 25°C.
- * Parallel operation with other model is not possible.

External view

1. SMD(type B)

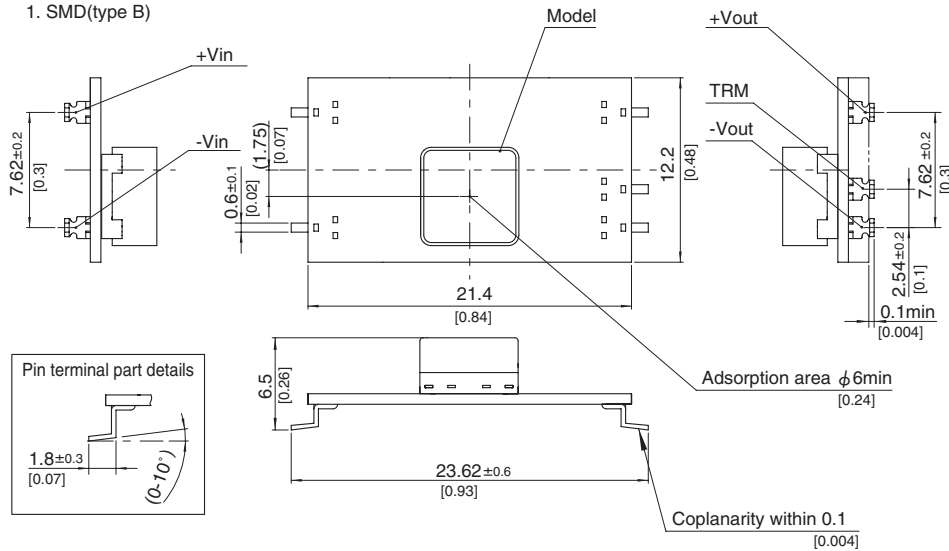

Recommended Pad and Hole dia. (TOP VIEW)

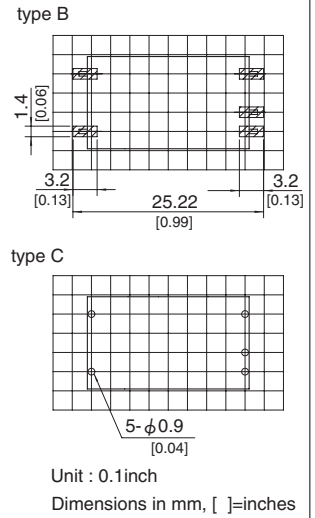

2. DIP(type C)

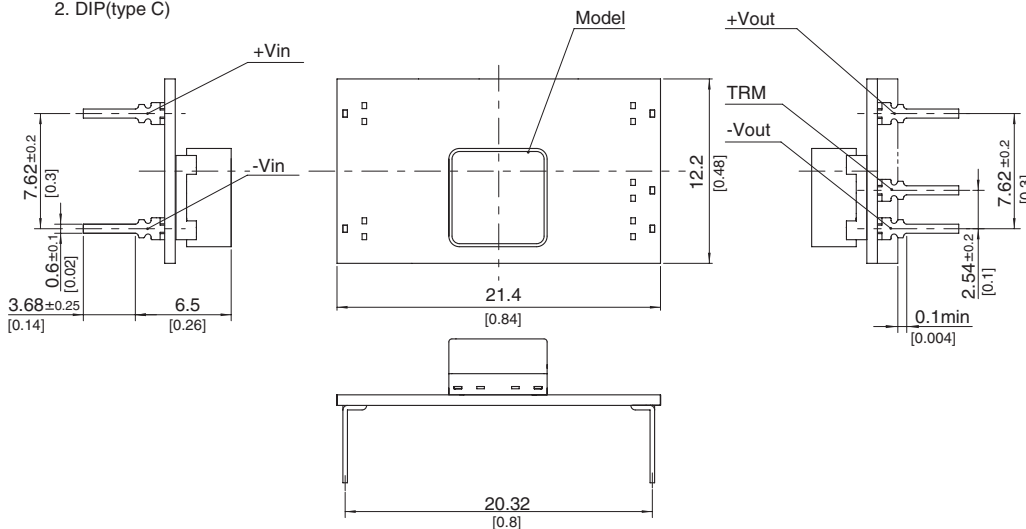

- ※ Tolerance ±0.5 [±0.02]
- ※ Dimensions in mm, []=inches
- ※ Pin terminal thickness : 0.3±0.1 [0.012]
- ※ Pin terminal material : Copper alloy
- ※ Plating treatment of terminal : Lead free plating
- ※ Weight : 2g max

SUW1R5

SU W 1R5 12 12 B P

① ② ③ ④ ⑤ ⑥ ⑦



RoHS

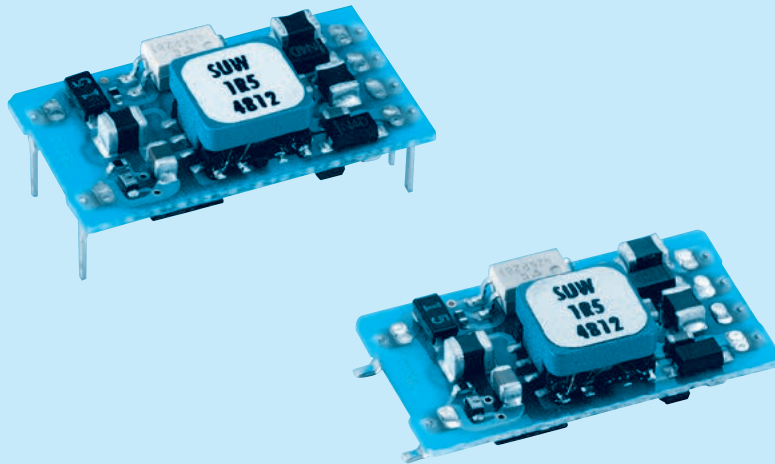

- ① Series name
- ② Dual output
- ③ Output wattage
- ④ Input voltage
- ⑤ Output voltage
- ⑥ Mounting type
B :SMD
C :DIP
- ⑦ Packing form
Blank:Plastic cover
P :Tray (SMD type)

MODEL	SUW1R50512	SUW1R50515	SUW1R51212	SUW1R51215	SUW1R52412	SUW1R52415	SUW1R54812	SUW1R54815	
MAX OUTPUT WATTAGE[W]	1.56	1.5	1.56	1.5	1.56	1.5	1.56	1.5	
DC OUTPUT	VOLTAGE[V] *1	± 12 or +24	± 15 or +30	± 12 or +24	± 15 or +30	± 12 or +24	± 15 or +30	± 12 or +24	± 15 or +30
	CURRENT[A]	0.065	0.05	0.065	0.05	0.065	0.05	0.065	0.05

SPECIFICATIONS

	MODEL	SUW1R50512	SUW1R50515	SUW1R51212	SUW1R51215	SUW1R52412	SUW1R52415	SUW1R54812	SUW1R54815	
INPUT	VOLTAGE[V]	DC4.5 - 9		DC9 - 18		DC18 - 36		DC36 - 76		
	CURRENT[A] *2	0.433typ	0.417typ	0.173typ	0.167typ	0.087typ	0.083typ	0.043typ	0.042typ	
	EFFICIENCY[%] *2	72typ	72typ	75typ	75typ	75typ	75typ	75typ	75typ	
OUTPUT	VOLTAGE[V]	± 12(+24)	± 15(+30)	± 12(+24)	± 15(+30)	± 12(+24)	± 15(+30)	± 12(+24)	± 15(+30)	
	CURRENT[A]	0.065	0.05	0.065	0.05	0.065	0.05	0.065	0.05	
	LINE REGULATION[mV]	60max	75max	60max	75max	60max	75max	60max	75max	
	LOAD REGULATION[mV]	600max	750max	600max	750max	600max	750max	600max	750max	
	RIPPLE[mVp-p]	-20 to +55°C *3	120max	120max	120max	120max	120max	120max	120max	120max
		-40 to -20°C *3	150max	150max	150max	150max	150max	150max	150max	150max
	RIPPLE NOISE[mVp-p]	-20 to +55°C *3	150max	150max	150max	150max	150max	150max	150max	150max
		-40 to -20°C *3	200max	200max	200max	200max	200max	200max	200max	200max
	TEMPERATURE REGULATION[mV]	-20 to +55°C	150max	180max	150max	180max	150max	180max	150max	180max
		-40 to +55°C	240max	290max	240max	290max	240max	290max	240max	290max
DRIFT[mV] *4	50max	60max	50max	60max	50max	60max	50max	60max		
START-UP TIME[ms]	20max (Minimum input, Io=100%)									
OUTPUT VOLTAGE ADJUSTMENT RANGE	Fixed (TRM pin open) ±5% adjustable by external VR									
OUTPUT VOLTAGE SETTING[V] (±5%)	11.40 - 12.60	14.25 - 15.75	11.40 - 12.60	14.25 - 15.75	11.40 - 12.60	14.25 - 15.75	11.40 - 12.60	14.25 - 15.75		
PROTECTION CIRCUIT AND OTHERS	OVERCURRENT PROTECTION	Works over 105% of rating and recovers automatically								
ISOLATION	INPUT-OUTPUT	AC500V 1minute, Cutoff current = 10mA, DC500V 50MΩ min (20±15°C)								
ENVIRONMENT	OPERATING TEMP.,HUMID.AND ALTITUDE	-40 to +85°C, 20 - 95%RH (Non condensing) (Refer to "Derating"), 3,000m (10,000feet) max								
	STORAGE TEMP.,HUMID.AND ALTITUDE	-40 to +100°C, 20 - 95%RH (Non condensing), 9,000m (30,000feet) max								
	VIBRATION	10 - 55Hz, 98.0m/s ² (10G), 3minutes period, 60minutes each along X, Y and Z axis								
	IMPACT	490.3m/s ² (50G), 11ms, once each along X, Y and Z axis								
SAFETY	AGENCY APPROVALS	UL60950-1, C-UL, EN62368-1								
OTHERS	CASE SIZE/WEIGHT	21.4 × 6.5 × 12.2mm [0.84 × 0.26 × 0.48 inches] (W×H×D) / 2g max								
	COOLING METHOD	Convection/Forced air								

*1 Output pins can be connected in series to make a 24V/30V output.
 *2 Rated input 5V, 12V, 24V or 48V DC Io=100%
 *3 Ripple and Ripple Noise is measured by using measuring board with capacitor with in 25mm from output pin terminals.
 *4 Drift is the change in DC output for an eight hour period after a half-hour warm-up at 25°C.
 * Parallel operation with other model is not possible.

External view

1. SMD(type B)

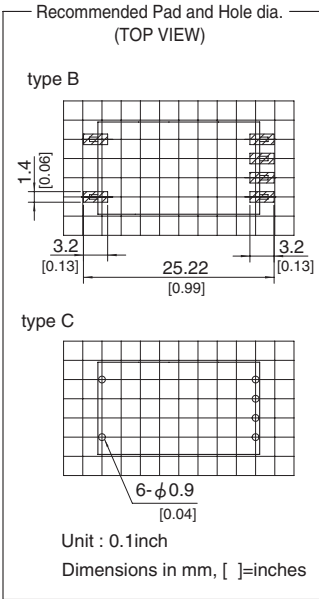
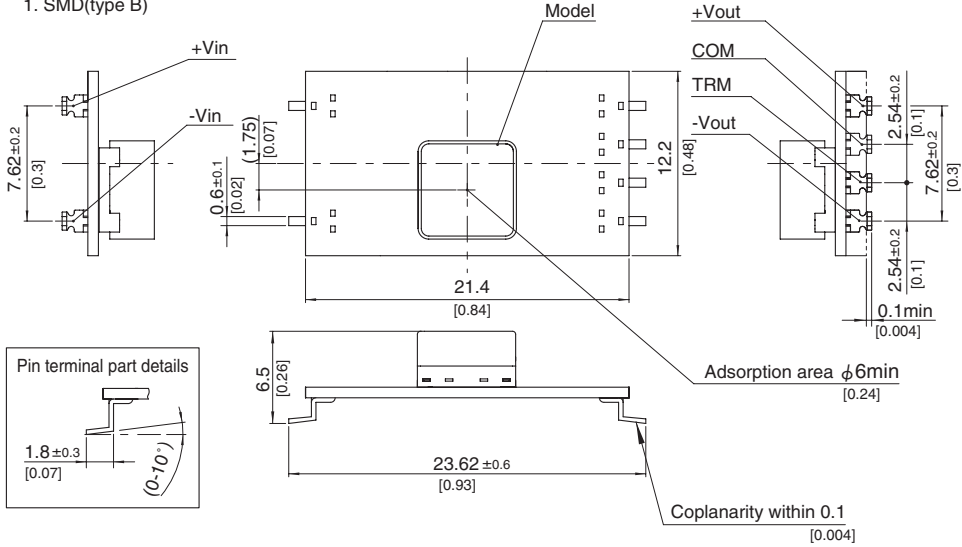

2. DIP(type C)

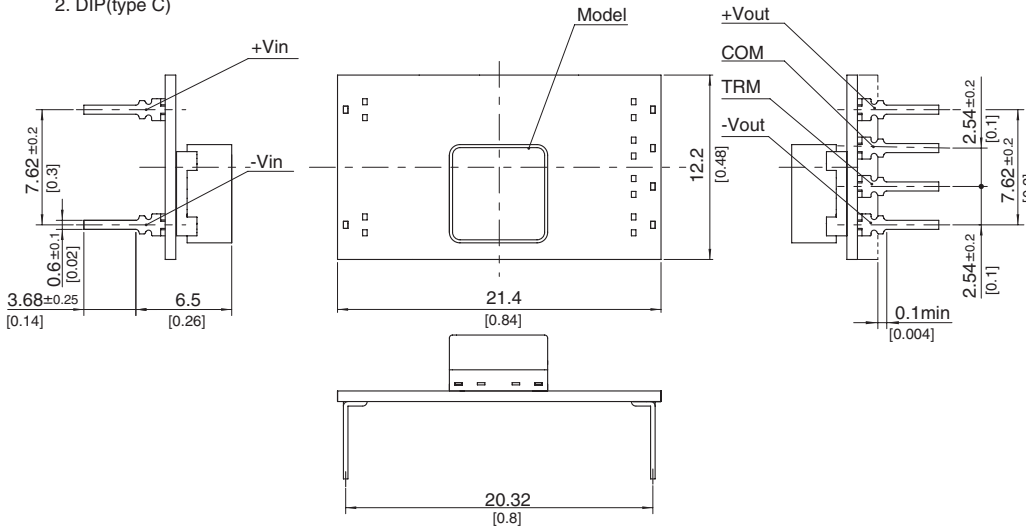

- ※ Tolerance ± 0.5 [± 0.02]
- ※ Dimensions in mm, []=inches
- ※ Pin terminal thickness : 0.3 ± 0.1 [0.012]
- ※ Pin terminal material : Copper alloy
- ※ Plating treatment of terminal : Lead free plating
- ※ Weight : 2g max

SUS3

SU S 3 12 05 B P - □

① ② ③ ④ ⑤ ⑥ ⑦ ⑧

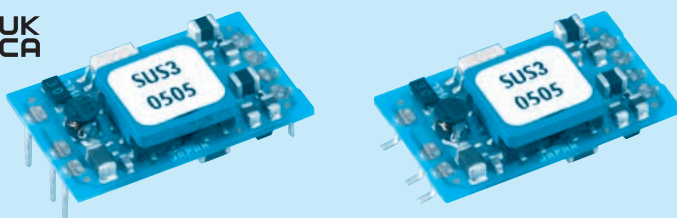

- ① Series name
- ② Single output
- ③ Output wattage
- ④ Input voltage
- ⑤ Output voltage
- ⑥ Mounting type
B : SMD
C : DIP
- ⑦ Packing form
Blank: Plastic cover
P : Tray (SMD type)
- ⑧ Optional
G : Capacitor between Input and Output is removed.

MODEL	SUS3053R3	SUS30505	SUS30512	SUS30515	SUS3123R3	SUS31205	SUS31212	SUS31215
MAX OUTPUT WATTAGE[W]	1.98	3	3	3	1.98	3	3	3
DC OUTPUT	VOLTAGE[V] *1	3.3	5	12	15	3.3	5	12
	CURRENT[A]	0.6	0.6	0.25	0.2	0.6	0.6	0.25

SPECIFICATIONS

	MODEL	SUS3053R3	SUS30505	SUS30512	SUS30515	SUS3123R3	SUS31205	SUS31212	SUS31215	
INPUT	VOLTAGE[V]	DC4.5 - 9				DC9 - 18				
	CURRENT[A] *2	0.536typ	0.780typ	0.760typ	0.760typ	0.218typ	0.317typ	0.309typ	0.313typ	
	EFFICIENCY[%] *2	74typ	77typ	79typ	79typ	76typ	79typ	81typ	80typ	
OUTPUT	VOLTAGE[V]	3.3	5	12	15	3.3	5	12	15	
	CURRENT[A]	0.6	0.6	0.25	0.2	0.6	0.6	0.25	0.2	
	LINE REGULATION[mV]	20max	20max	48max	60max	20max	20max	48max	60max	
	LOAD REGULATION[mV]	40max	40max	100max	120max	40max	40max	100max	120max	
	RIPPLE[mVp-p]	-20 to +55°C *3	80max	80max	120max	120max	80max	80max	120max	120max
		-40 to -20°C *3	120max	120max	150max	150max	120max	120max	150max	150max
	RIPPLE NOISE[mVp-p]	-20 to +55°C *3	120max	120max	150max	150max	120max	120max	150max	150max
		-40 to -20°C *3	200max	200max	200max	200max	200max	200max	200max	200max
	TEMPERATURE REGULATION[mV]	-20 to +55°C	50max	50max	150max	180max	50max	50max	150max	180max
		-40 to +55°C	80max	80max	240max	290max	80max	80max	240max	290max
DRIFT[mV] *4	20max	20max	48max	60max	20max	20max	48max	60max		
START-UP TIME[ms]	20max (Minimum input, I _o =100%)									
OUTPUT VOLTAGE ADJUSTMENT RANGE	Fixed (TRM pin open) ±5% adjustable by external VR									
OUTPUT VOLTAGE SETTING[V] (±3%)	3.21 - 3.42	4.90 - 5.21	11.64 - 12.36	14.55 - 15.45	3.21 - 3.42	4.90 - 5.21	11.64 - 12.36	14.55 - 15.45		
PROTECTION CIRCUIT AND OTHERS	OVERCURRENT PROTECTION	Works over 105% of rating and recovers automatically								
	REMOTE ON/OFF	Provided (Negative logic L : ON, H : OFF)								

MODEL	SUS3243R3	SUS32405	SUS32412	SUS32415	SUS3483R3	SUS34805	SUS34812	SUS34815
MAX OUTPUT WATTAGE[W]	1.98	3	3	3	1.98	3	3	3
DC OUTPUT	VOLTAGE[V] *1	3.3	5	12	15	3.3	5	12
	CURRENT[A]	0.6	0.6	0.25	0.2	0.6	0.6	0.25

SPECIFICATIONS

	MODEL	SUS3243R3	SUS32405	SUS32412	SUS32415	SUS3483R3	SUS34805	SUS34812	SUS34815	
INPUT	VOLTAGE[V]	DC18 - 36				DC36 - 76				
	CURRENT[A] *2	0.110typ	0.159typ	0.155typ	0.157typ	0.056typ	0.080typ	0.078typ	0.078typ	
	EFFICIENCY[%] *2	75typ	79typ	81typ	80typ	74typ	79typ	81typ	81typ	
OUTPUT	VOLTAGE[V]	3.3	5	12	15	3.3	5	12	15	
	CURRENT[A]	0.6	0.6	0.25	0.2	0.6	0.6	0.25	0.2	
	LINE REGULATION[mV]	20max	20max	48max	60max	20max	20max	48max	60max	
	LOAD REGULATION[mV]	40max	40max	100max	120max	40max	40max	100max	120max	
	RIPPLE[mVp-p]	-20 to +55°C *3	80max	80max	120max	120max	80max	80max	120max	120max
		-40 to -20°C *3	120max	120max	150max	150max	120max	120max	150max	150max
	RIPPLE NOISE[mVp-p]	-20 to +55°C *3	120max	120max	150max	150max	120max	120max	150max	150max
		-40 to -20°C *3	200max	200max	200max	200max	200max	200max	200max	200max
	TEMPERATURE REGULATION[mV]	-20 to +55°C	50max	50max	150max	180max	50max	50max	150max	180max
		-40 to +55°C	80max	80max	240max	290max	80max	80max	240max	290max
DRIFT[mV] *4	20max	20max	48max	60max	20max	20max	48max	60max		
START-UP TIME[ms]	20max (Minimum input, I _o =100%)									
OUTPUT VOLTAGE ADJUSTMENT RANGE	Fixed (TRM pin open) ±5% adjustable by external VR									
OUTPUT VOLTAGE SETTING[V] (±3%)	3.21 - 3.42	4.90 - 5.21	11.64 - 12.36	14.55 - 15.45	3.21 - 3.42	4.90 - 5.21	11.64 - 12.36	14.55 - 15.45		
PROTECTION CIRCUIT AND OTHERS	OVERCURRENT PROTECTION	Works over 105% of rating and recovers automatically								
	REMOTE ON/OFF	Provided (Negative logic L : ON, H : OFF)								

GENERAL SPECIFICATIONS

ISOLATION	INPUT-OUTPUT	AC500V 1minute, Cutoff current = 10mA, DC500V 50MΩ min (20±15°C)
ENVIRONMENT	OPERATING TEMP., HUMID. AND ALTITUDE	-40 to +85°C, 20 - 95%RH (Non condensing) (Refer to "Derating"), 3,000m (10,000feet) max
	STORAGE TEMP., HUMID. AND ALTITUDE	-40 to +100°C, 20 - 95%RH (Non condensing), 9,000m (30,000feet) max
	VIBRATION	10 - 55Hz, 98.0m/s ² (10G), 3minutes period, 60minutes each along X, Y and Z axis
	IMPACT	490.3m/s ² (50G), 11ms, once each along X, Y and Z axis
SAFETY	AGENCY APPROVALS	UL60950-1, C-UL, EN62368-1
OTHERS	CASE SIZE/WEIGHT	24 X 6.5 X 15.1mm [0.94 X 0.26 X 0.59 inches] (W X H X D) / 3g max
	COOLING METHOD	Convection/Forced air

- *1 SUW3xx12/SUW3xx15 is available as single output, +24V/+30V.
- *2 Rated input 5V, 12V, 24V or 48V DC I_o=100%
- *3 Ripple and Ripple Noise is measured by using measuring board with capacitor with in 25mm from output pin terminals.
- *4 Drift is the change in DC output for an eight hour period after a half-hour warm-up at 25°C.
- * Parallel operation with other model is not possible.

External view

1. SMD (type B)

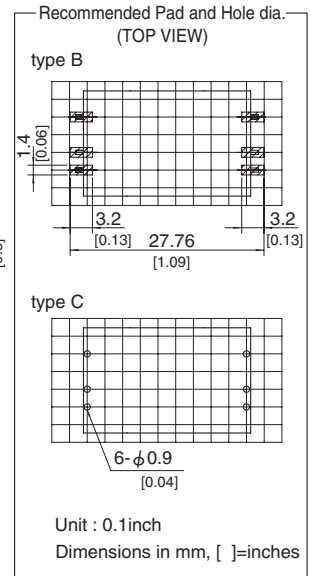
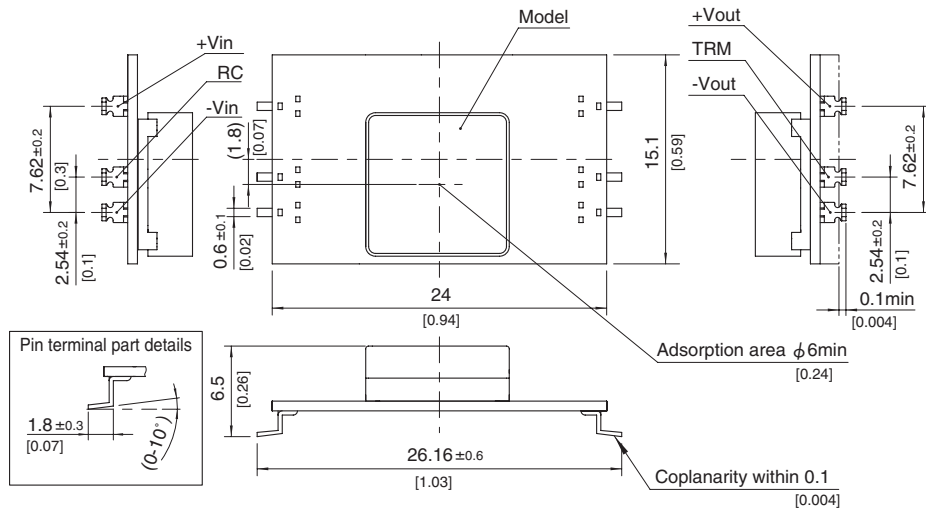

2. DIP (type C)

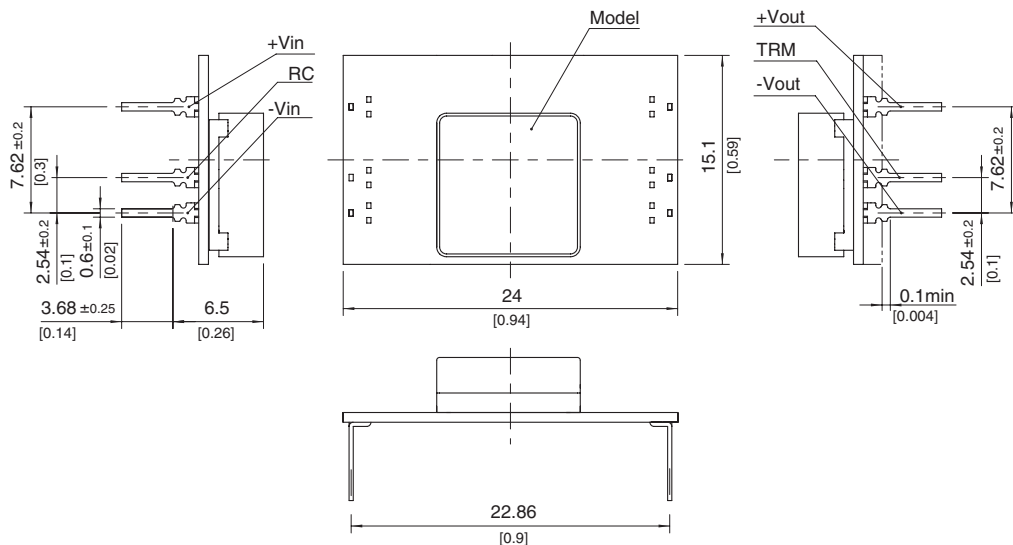

- ※ Tolerance ±0.5 [±0.02]
- ※ Dimensions in mm, []=inches
- ※ Pin terminal thickness : 0.3±0.1 [0.012]
- ※ Pin terminal material : Copper alloy
- ※ Plating treatment of terminal : Lead free plating
- ※ Weight : 3g max

SUW3

SU W 3 12 12 B P - □
 ① ② ③ ④ ⑤ ⑥ ⑦ ⑧



RoHS

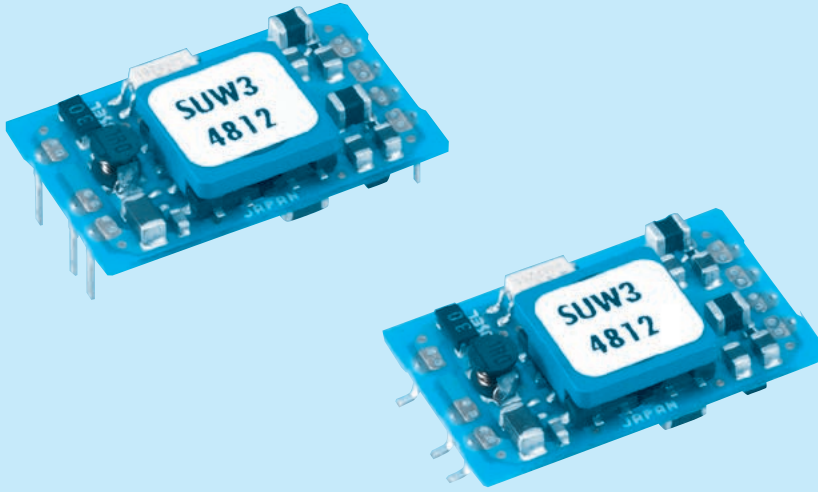

- ① Series name
- ② Dual output
- ③ Output wattage
- ④ Input voltage
- ⑤ Output voltage
- ⑥ Mounting type
B : SMD
C : DIP
- ⑦ Packing form
Blank: Plastic cover
P : Tray (SMD type)
- ⑧ Optional
G : Capacitor between Input and Output is removed.

MODEL	SUW30512	SUW30515	SUW31212	SUW31215	SUW32412	SUW32415	SUW34812	SUW34815	
MAX OUTPUT WATTAGE[W]	3.12	3	3.12	3	3.12	3	3.12	3	
DC OUTPUT	VOLTAGE[V] *1	±12 or +24	±15 or +30	±12 or +24	±15 or +30	±12 or +24	±15 or +30	±12 or +24	±15 or +30
	CURRENT[A]	0.13	0.1	0.13	0.1	0.13	0.1	0.13	0.1

SPECIFICATIONS

	MODEL	SUW30512	SUW30515	SUW31212	SUW31215	SUW32412	SUW32415	SUW34812	SUW34815	
INPUT	VOLTAGE[V]	DC4.5 - 9		DC9 - 18		DC18 - 36		DC36 - 76		
	CURRENT[A] *2	0.822typ	0.790typ	0.334typ	0.321typ	0.167typ	0.161typ	0.084typ	0.081typ	
	EFFICIENCY[%] *2	76typ	76typ	78typ	78typ	78typ	78typ	78typ	78typ	
OUTPUT	VOLTAGE[V]	±12(+24)	±15(+30)	±12(+24)	±15(+30)	±12(+24)	±15(+30)	±12(+24)	±15(+30)	
	CURRENT[A]	0.13	0.1	0.13	0.1	0.13	0.1	0.13	0.1	
	LINE REGULATION[mV]	60max	75max	60max	75max	60max	75max	60max	75max	
	LOAD REGULATION[mV]	600max	750max	600max	750max	600max	750max	600max	750max	
	RIPPLE[mVp-p]	-20 to +55°C *3	120max	120max	120max	120max	120max	120max	120max	120max
		-40 to -20°C *3	150max	150max	150max	150max	150max	150max	150max	150max
	RIPPLE NOISE[mVp-p]	-20 to +55°C *3	150max	150max	150max	150max	150max	150max	150max	150max
		-40 to -20°C *3	200max	200max	200max	200max	200max	200max	200max	200max
	TEMPERATURE REGULATION[mV]	-20 to +55°C	150max	180max	150max	180max	150max	180max	150max	180max
	-40 to +55°C	240max	290max	240max	290max	240max	290max	240max	290max	
DRIFT[mV] *4	50max	60max	50max	60max	50max	60max	50max	60max		
START-UP TIME[ms]	20max (Minimum input, Io=100%)									
OUTPUT VOLTAGE ADJUSTMENT RANGE	Fixed (TRM pin open) ±5% adjustable by external VR									
OUTPUT VOLTAGE SETTING[V] (±5%)	11.40 - 12.60	14.25 - 15.75	11.40 - 12.60	14.25 - 15.75	11.40 - 12.60	14.25 - 15.75	11.40 - 12.60	14.25 - 15.75		
PROTECTION CIRCUIT AND OTHERS	OVERCURRENT PROTECTION	Works over 105% of rating and recovers automatically								
	REMOTE ON/OFF	Provided (Negative logic L : ON, H : OFF)								
ISOLATION	INPUT-OUTPUT	AC500V 1minute, Cutoff current = 10mA, DC500V 50MΩ min (20±15°C)								
ENVIRONMENT	OPERATING TEMP., HUMID. AND ALTITUDE	-40 to +85°C, 20 - 95%RH (Non condensing) (Refer to "Derating"), 3,000m (10,000feet) max								
	STORAGE TEMP., HUMID. AND ALTITUDE	-40 to +100°C, 20 - 95%RH (Non condensing), 9,000m (30,000feet) max								
	VIBRATION	10 - 55Hz, 98.0m/s ² (10G), 3minutes period, 60minutes each along X, Y and Z axis								
	IMPACT	490.3m/s ² (50G), 11ms, once each along X, Y and Z axis								
SAFETY	AGENCY APPROVALS	UL60950-1, C-UL, EN62368-1								
OTHERS	CASE SIZE/WEIGHT	24 × 6.5 × 15.1mm [0.94 × 0.26 × 0.59 inches] (W × H × D) / 3g max								
	COOLING METHOD	Convection/Forced air								

*1 Output pins can be connected in series to make a 24V/30V output.
 *2 Rated input 5V, 12V, 24V or 48V DC Io=100%
 *3 Ripple and Ripple Noise is measured by using measuring board with capacitor with in 25mm from output pin terminals.
 *4 Drift is the change in DC output for an eight hour period after a half-hour warm-up at 25°C.
 * Parallel operation with other model is not possible.

External view

1.SMD(type B)

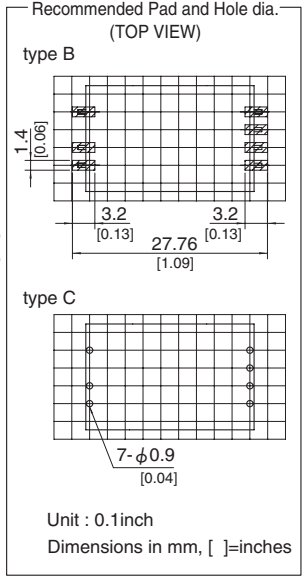
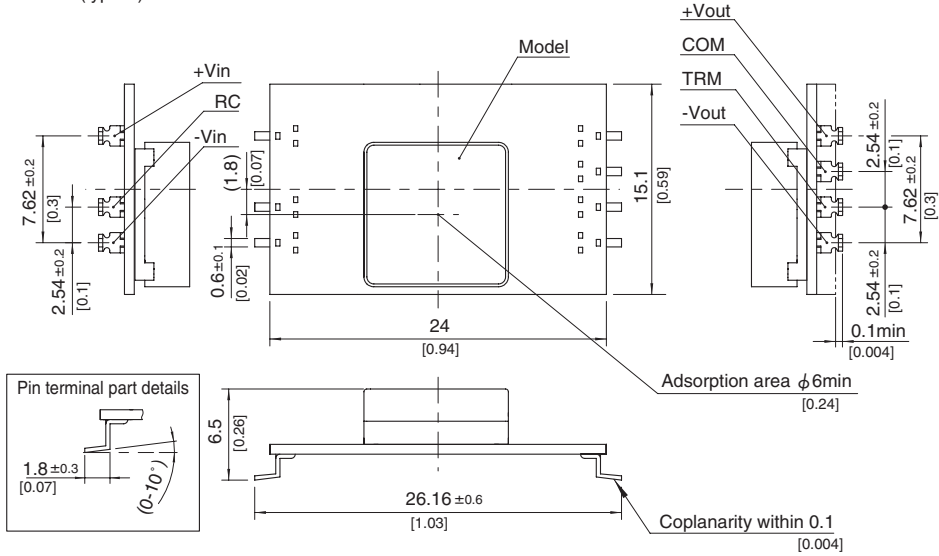

2.DIP(type C)

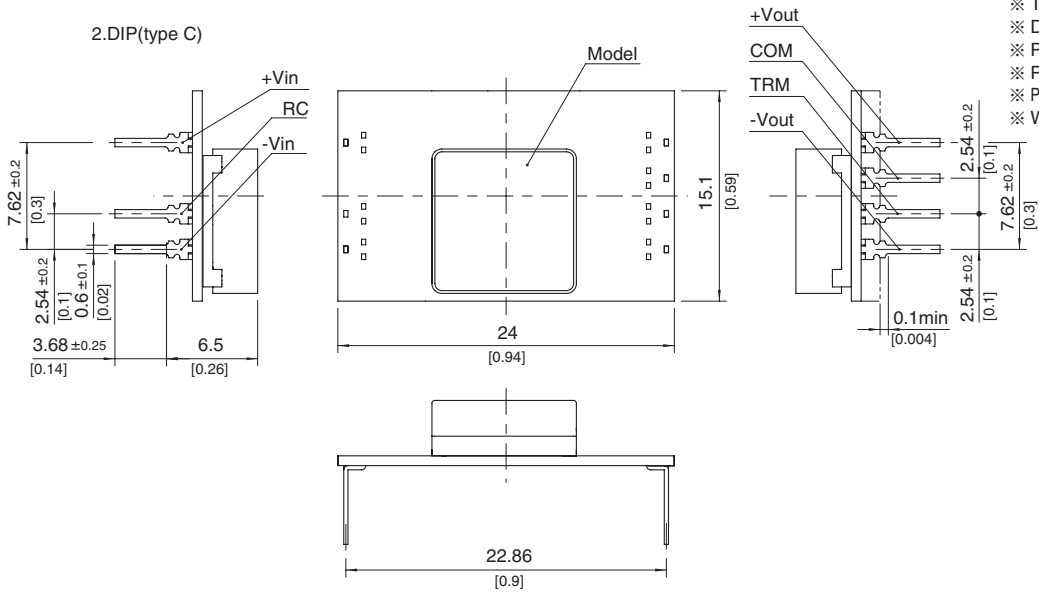

- ※ Tolerance ± 0.5 [± 0.02]
- ※ Dimensions in mm, []=inches
- ※ Pin terminal thickness : 0.3 ± 0.1 [0.012]
- ※ Pin terminal material : Copper alloy
- ※ Plating treatment of terminal : Lead free plating
- ※ Weight : 3g max

SUS6

SU S 6 12 05 B P - □

① ② ③ ④ ⑤ ⑥ ⑦ ⑧

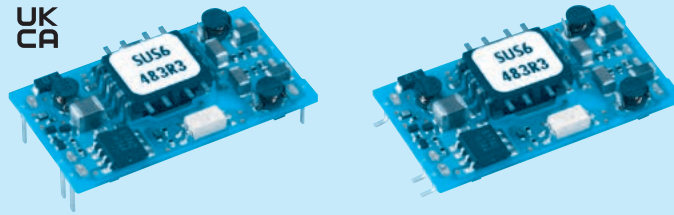
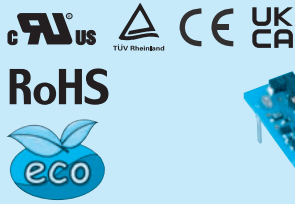

- ① Series name
- ② Single output
- ③ Output wattage
- ④ Input voltage
- ⑤ Output voltage
- ⑥ Mounting type
B : SMD
C : DIP
- ⑦ Packing form
Blank: Plastic cover
P : Tray (SMD type)
- ⑧ Optional
G : Capacitor between Input and Output is removed.

MODEL	SUS6053R3	SUS60505	SUS60512	SUS60515	SUS6123R3	SUS61205	SUS61212	SUS61215	
MAX OUTPUT WATTAGE[W]	3.96	5	6	6	4.46	6	6	6	
DC OUTPUT	VOLTAGE[V] *1	3.3	5	12	15	3.3	5	12	15
	CURRENT[A]	1.2	1	0.5	0.4	1.35	1.2	0.5	0.4

SPECIFICATIONS

	MODEL	SUS6053R3	SUS60505	SUS60512	SUS60515	SUS6123R3	SUS61205	SUS61212	SUS61215	
INPUT	VOLTAGE[V]	DC4.5 - 9				DC9 - 18				
	CURRENT[A] *2	1.100typ	1.316typ	1.500typ	1.500typ	0.502typ	0.617typ	0.588typ	0.588typ	
	EFFICIENCY[%] *2	72typ	76typ	80typ	80typ	74typ	81typ	85typ	85typ	
OUTPUT	VOLTAGE[V]	3.3	5	12	15	3.3	5	12	15	
	CURRENT[A]	1.2	1	0.5	0.4	1.35	1.2	0.5	0.4	
	LINE REGULATION[mV]	20max	20max	48max	60max	20max	20max	48max	60max	
	LOAD REGULATION[mV]	40max	40max	100max	120max	40max	40max	100max	120max	
	RIPPLE[mVp-p]	-20 to +55°C *3	80max	80max	120max	120max	80max	80max	120max	120max
		-40 to -20°C *3	120max	120max	150max	150max	120max	120max	150max	150max
	RIPPLE NOISE[mVp-p]	-20 to +55°C *3	120max	120max	150max	150max	120max	120max	150max	150max
		-40 to -20°C *3	200max	200max	200max	200max	200max	200max	200max	200max
	TEMPERATURE REGULATION[mV]	-20 to +55°C	50max	50max	150max	180max	50max	50max	150max	180max
		-40 to +55°C	80max	80max	240max	290max	80max	80max	240max	290max
	DRIFT[mV] *4	20max	20max	48max	60max	20max	20max	48max	60max	
START-UP TIME[ms]	20max (Minimum input, I _o =100%)									
OUTPUT VOLTAGE ADJUSTMENT RANGE	Fixed (TRM pin open) ±5% adjustable by external VR									
OUTPUT VOLTAGE SETTING[V] (±3%)	3.21 - 3.42	4.90 - 5.21	11.64 - 12.36	14.55 - 15.45	3.21 - 3.42	4.90 - 5.21	11.64 - 12.36	14.55 - 15.45		
PROTECTION CIRCUIT AND OTHERS	OVERCURRENT PROTECTION	Works over 105% of rating and recovers automatically								
	REMOTE ON/OFF	Provided (Negative logic L : ON, H : OFF)								

MODEL	SUS6243R3	SUS62405	SUS62412	SUS62415	SUS6483R3	SUS64805	SUS64812	SUS64815	
MAX OUTPUT WATTAGE[W]	4.46	6	6	6	4.46	6	6	6	
DC OUTPUT	VOLTAGE[V] *1	3.3	5	12	15	3.3	5	12	15
	CURRENT[A]	1.35	1.2	0.5	0.4	1.35	1.2	0.5	0.4

SPECIFICATIONS

	MODEL	SUS6243R3	SUS62405	SUS62412	SUS62415	SUS6483R3	SUS64805	SUS64812	SUS64815	
INPUT	VOLTAGE[V]	DC18 - 36				DC36 - 76				
	CURRENT[A] *2	0.248typ	0.309typ	0.291typ	0.291typ	0.121typ	0.154typ	0.145typ	0.145typ	
	EFFICIENCY[%] *2	75typ	81typ	86typ	86typ	77typ	81typ	86typ	86typ	
OUTPUT	VOLTAGE[V]	3.3	5	12	15	3.3	5	12	15	
	CURRENT[A]	1.35	1.2	0.5	0.4	1.35	1.2	0.5	0.4	
	LINE REGULATION[mV]	20max	20max	48max	60max	20max	20max	48max	60max	
	LOAD REGULATION[mV]	40max	40max	100max	120max	40max	40max	100max	120max	
	RIPPLE[mVp-p]	-20 to +55°C *3	80max	80max	120max	120max	80max	80max	120max	120max
		-40 to -20°C *3	120max	120max	150max	150max	120max	120max	150max	150max
	RIPPLE NOISE[mVp-p]	-20 to +55°C *3	120max	120max	150max	150max	120max	120max	150max	150max
		-40 to -20°C *3	200max	200max	200max	200max	200max	200max	200max	200max
	TEMPERATURE REGULATION[mV]	-20 to +55°C	50max	50max	150max	180max	50max	50max	150max	180max
		-40 to +55°C	80max	80max	240max	290max	80max	80max	240max	290max
	DRIFT[mV] *4	20max	20max	48max	60max	20max	20max	48max	60max	
START-UP TIME[ms]	20max (Minimum input, I _o =100%)									
OUTPUT VOLTAGE ADJUSTMENT RANGE	Fixed (TRM pin open) ±5% adjustable by external VR									
OUTPUT VOLTAGE SETTING[V] (±3%)	3.21 - 3.42	4.90 - 5.21	11.64 - 12.36	14.55 - 15.45	3.21 - 3.42	4.90 - 5.21	11.64 - 12.36	14.55 - 15.45		
PROTECTION CIRCUIT AND OTHERS	OVERCURRENT PROTECTION	Works over 105% of rating and recovers automatically								
	REMOTE ON/OFF	Provided (Negative logic L : ON, H : OFF)								

GENERAL SPECIFICATIONS

ISOLATION	INPUT-OUTPUT	AC500V 1minute, Cutoff current = 10mA, DC500V 50MΩ min (20±15°C)
ENVIRONMENT	OPERATING TEMP.,HUMID.AND ALTITUDE	-40 to +85°C, 20 - 95%RH (Non condensing) (Refer to "Derating"), 3,000m (10,000feet) max
	STORAGE TEMP.,HUMID.AND ALTITUDE	-40 to +100°C, 20 - 95%RH (Non condensing), 9,000m (30,000feet) max
	VIBRATION	10 - 55Hz, 98.0m/s ² (10G), 3minutes period, 60minutes each along X, Y and Z axis
	IMPACT	490.3m/s ² (50G), 11ms, once each along X, Y and Z axis
SAFETY	AGENCY APPROVALS	UL60950-1, C-UL, EN62368-1
OTHERS	CASE SIZE/WEIGHT	31.6×6.5×18.1mm [1.24×0.26×0.71 inches] (W×H×D) / 4g max
	COOLING METHOD	Convection/Forced air

- *1 SUW6xx12/SUW6xx15 is available as single output, +24V/+30V.
- *2 Rated input 5V, 12V, 24V or 48V DC I_o=100%
- *3 Ripple and Ripple Noise is measured by using measuring board with capacitor with in 25mm from output pin terminals.
- *4 Drift is the change in DC output for an eight hour period after a half-hour warm-up at 25°C.
- * Parallel operation with other model is not possible.

External view

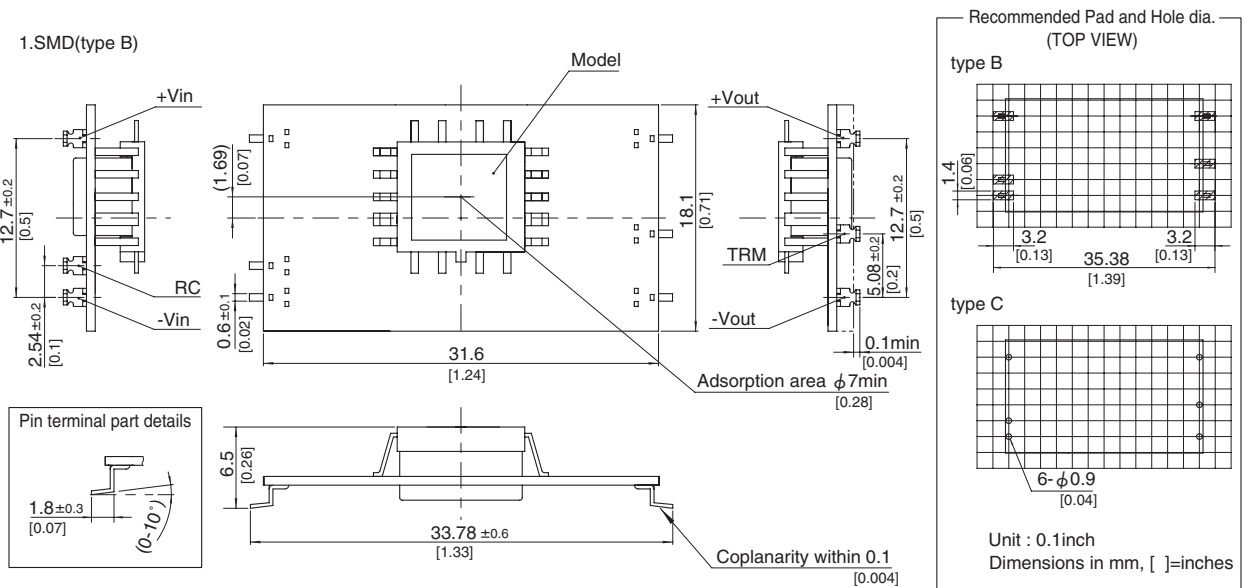

2.DIP(type C)

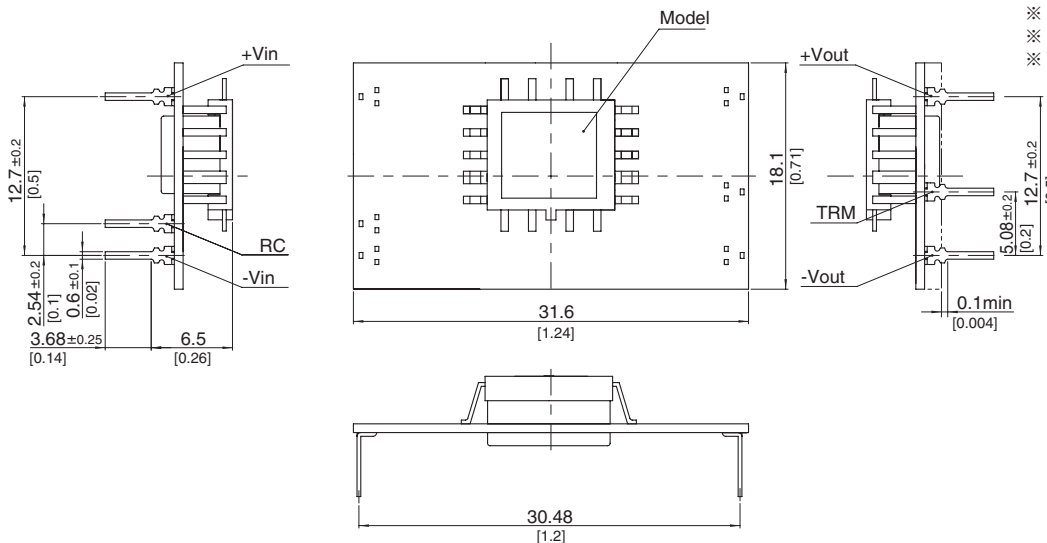

- ※ Tolerance ±0.5 [±0.02]
- ※ Dimensions in mm, []=inches
- ※ Pin terminal thickness : 0.3±0.1 [0.012]
- ※ Pin terminal material : Copper alloy
- ※ Plating treatment of terminal : Lead free plating
- ※ Weight : 4g max

SUW6

SU W 6 12 12 B P - □
 ① ② ③ ④ ⑤ ⑥ ⑦ ⑧



RoHS

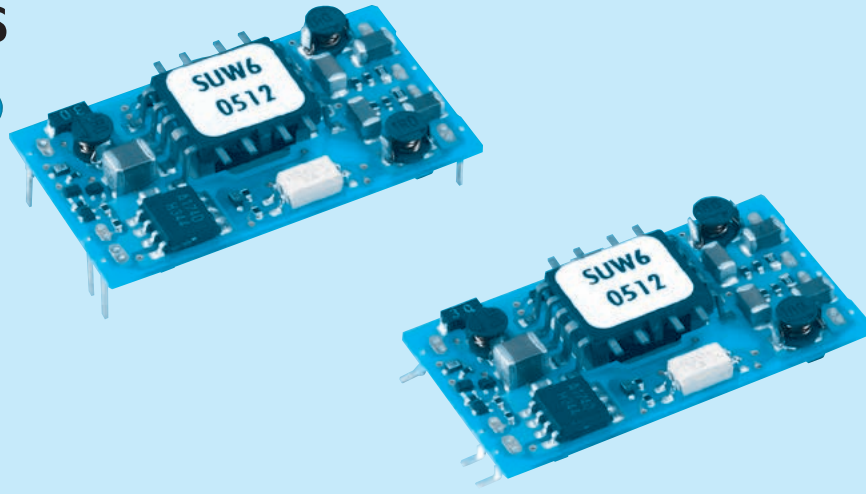

- ① Series name
- ② Dual output
- ③ Output wattage
- ④ Input voltage
- ⑤ Output voltage
- ⑥ Mounting type
B : SMD
C : DIP
- ⑦ Packing form
Blank: Plastic cover
P : Tray (SMD type)
- ⑧ Optional
G : Capacitor between Input and Output is removed.

MODEL	SUW60512	SUW60515	SUW61212	SUW61215	SUW62412	SUW62415	SUW64812	SUW64815	
MAX OUTPUT WATTAGE[W]	6	6	6	6	6	6	6	6	
DC OUTPUT	VOLTAGE[V] *1	±12 or +24	±15 or +30	±12 or +24	±15 or +30	±12 or +24	±15 or +30	±12 or +24	±15 or +30
	CURRENT[A]	0.25	0.2	0.25	0.2	0.25	0.2	0.25	0.2

SPECIFICATIONS

MODEL	SUW60512	SUW60515	SUW61212	SUW61215	SUW62412	SUW62415	SUW64812	SUW64815		
INPUT	VOLTAGE[V]	DC4.5 - 9		DC9 - 18		DC18 - 36		DC36 - 76		
	CURRENT[A] *2	1.538typ	1.538typ	0.588typ	0.588typ	0.291typ	0.291typ	0.145typ	0.145typ	
	EFFICIENCY[%] *2	78typ	78typ	85typ	85typ	86typ	86typ	86typ	86typ	
OUTPUT	VOLTAGE[V]	±12(+24)	±15(+30)	±12(+24)	±15(+30)	±12(+24)	±15(+30)	±12(+24)	±15(+30)	
	CURRENT[A]	0.25	0.2	0.25	0.2	0.25	0.2	0.25	0.2	
	LINE REGULATION[mV]	60max	75max	60max	75max	60max	75max	60max	75max	
	LOAD REGULATION[mV]	600max	750max	600max	750max	600max	750max	600max	750max	
	RIPPLE[mVp-p]	-20 to +55°C *3	120max	120max	120max	120max	120max	120max	120max	120max
		-40 to -20°C *3	150max	150max	150max	150max	150max	150max	150max	150max
	RIPPLE NOISE[mVp-p]	-20 to +55°C *3	150max	150max	150max	150max	150max	150max	150max	150max
		-40 to -20°C *3	200max	200max	200max	200max	200max	200max	200max	200max
	TEMPERATURE REGULATION[mV]	-20 to +55°C	150max	180max	150max	180max	150max	180max	150max	180max
		-40 to +55°C	240max	290max	240max	290max	240max	290max	240max	290max
DRIFT[mV] *4	50max	60max	50max	60max	50max	60max	50max	60max		
START-UP TIME[ms]	20max (Minimum input, Io=100%)									
OUTPUT VOLTAGE ADJUSTMENT RANGE	Fixed (TRM pin open) ±5% adjustable by external VR									
OUTPUT VOLTAGE SETTING[V] (±5%)	11.40 - 12.60	14.25 - 15.75	11.40 - 12.60	14.25 - 15.75	11.40 - 12.60	14.25 - 15.75	11.40 - 12.60	14.25 - 15.75		
PROTECTION CIRCUIT AND OTHERS	OVERCURRENT PROTECTION	Works over 105% of rating and recovers automatically								
	REMOTE ON/OFF	Provided (Negative logic L : ON, H : OFF)								
ISOLATION	INPUT-OUTPUT	AC500V 1minute, Cutoff current = 10mA, DC500V 50MΩ min (20±15°C)								
ENVIRONMENT	OPERATING TEMP., HUMID. AND ALTITUDE	-40 to +85°C, 20 - 95%RH (Non condensing) (Refer to "Derating"), 3,000m (10,000feet) max								
	STORAGE TEMP., HUMID. AND ALTITUDE	-40 to +100°C, 20 - 95%RH (Non condensing), 9,000m (30,000feet) max								
	VIBRATION	10 - 55Hz, 98.0m/s ² (10G), 3minutes period, 60minutes each along X, Y and Z axis								
	IMPACT	490.3m/s ² (50G), 11ms, once each along X, Y and Z axis								
SAFETY	AGENCY APPROVALS	UL60950-1, C-UL, EN62368-1								
OTHERS	CASE SIZE/WEIGHT	31.6 × 6.5 × 18.1mm [1.24 × 0.26 × 0.71 inches] (W × H × D) / 4g max								
	COOLING METHOD	Convection/Forced air								

*1 Output pins can be connected in series to make a 24V/30V output.
 *2 Rated input 5V, 12V, 24V or 48V DC Io=100%
 *3 Ripple and Ripple Noise is measured by using measuring board with capacitor with in 25mm from output pin terminals.
 *4 Drift is the change in DC output for an eight hour period after a half-hour warm-up at 25°C.
 * Parallel operation with other model is not possible.

External view

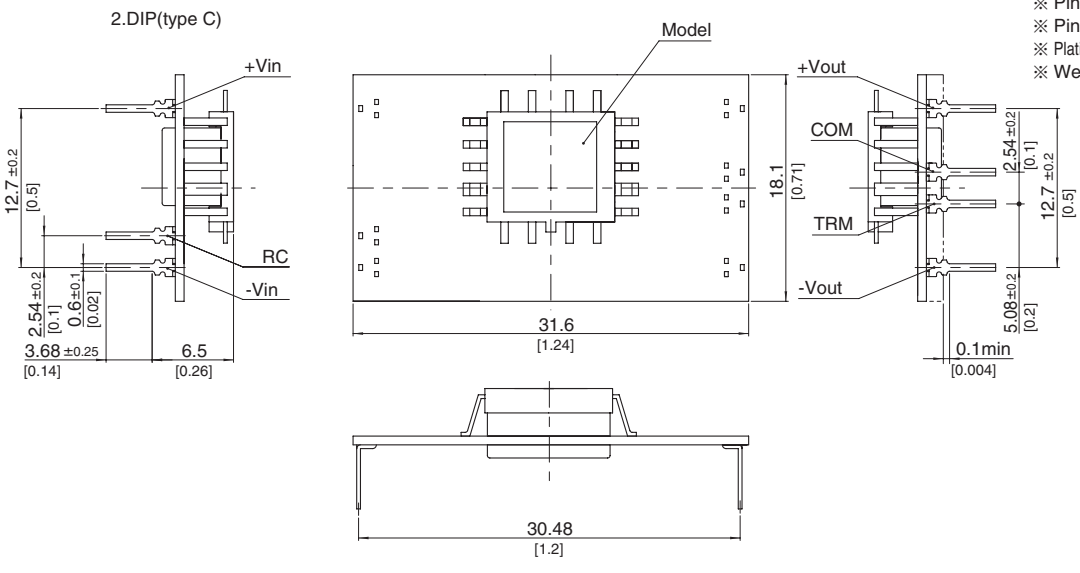
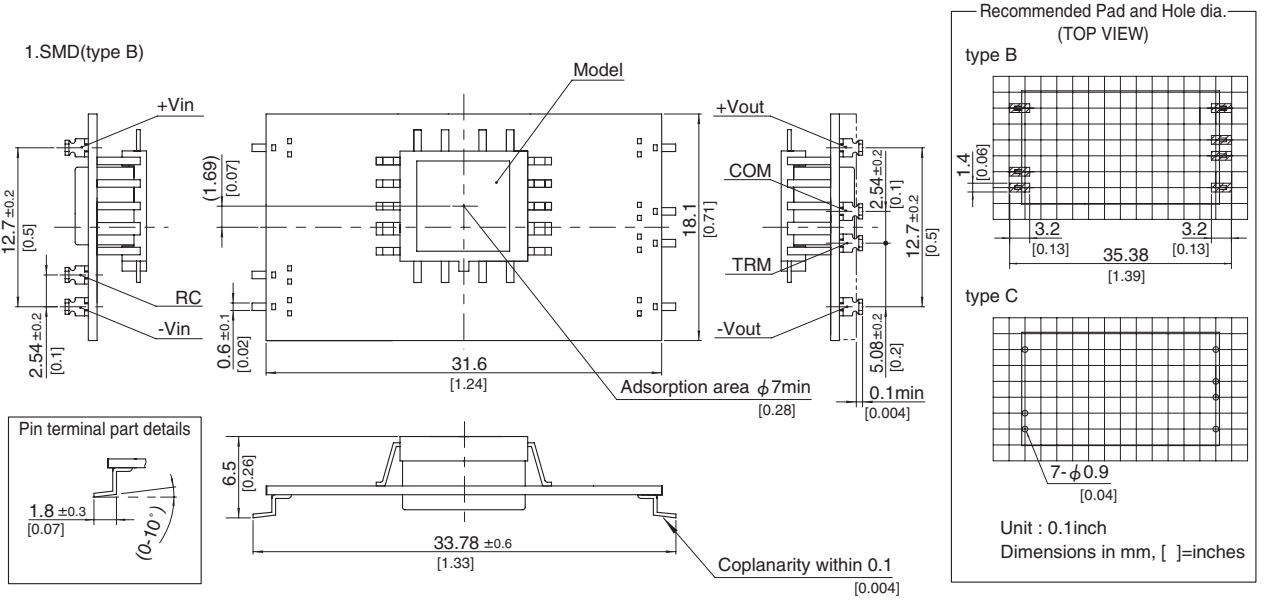

- ※ Tolerance ± 0.5 [± 0.02]
- ※ Dimensions in mm, []=inches
- ※ Pin terminal thickness : 0.3 ± 0.1 [0.012]
- ※ Pin terminal material : Copper alloy
- ※ Plating treatment of terminal : Lead free plating
- ※ Weight : 4g max

SUS10

SU S 10 12 05 B P - □

① ② ③ ④ ⑤ ⑥ ⑦ ⑧

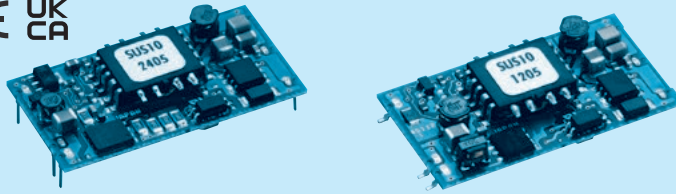
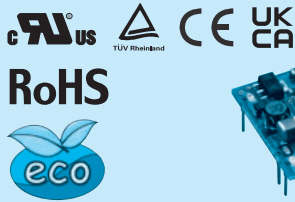

- ① Series name
- ② Single output
- ③ Output wattage
- ④ Input voltage
- ⑤ Output voltage
- ⑥ Mounting type
B : SMD
C : DIP
- ⑦ Packing form
Blank: Plastic cover
P : Tray (SMD type)
- ⑧ Optional
G : Capacitor between Input and Output is removed.

MODEL	SUS10053R3	SUS100505	SUS100512	SUS100515	SUS10123R3	SUS101205	SUS101212	SUS101215
MAX OUTPUT WATTAGE[W]	8.58	10	10.8	10.5	8.58	10	12	12
DC OUTPUT	VOLTAGE[V] *1	3.3	5	12	15	3.3	5	12
	CURRENT[A]	2.6	2	0.9	0.7	2.6	2	1

SPECIFICATIONS

	MODEL	SUS10053R3	SUS100505	SUS100512	SUS100515	SUS10123R3	SUS101205	SUS101212	SUS101215	
INPUT	VOLTAGE[V]	DC4.5 - 9				DC9 - 18				
	CURRENT[A] *2	2.12typ	2.41typ	2.54typ	2.47typ	0.872typ	0.980typ	1.15typ	1.15typ	
	EFFICIENCY[%] *2	81typ	83typ	85typ	85typ	82typ	85typ	87typ	87typ	
OUTPUT	VOLTAGE[V]	3.3	5	12	15	3.3	5	12	15	
	CURRENT[A]	2.6	2	0.9	0.7	2.6	2	1	0.8	
	LINE REGULATION[mV]	20max	20max	48max	60max	20max	20max	48max	60max	
	LOAD REGULATION[mV]	40max	40max	100max	120max	40max	40max	100max	120max	
	RIPPLE[mVp-p]	-20 to +55°C *3	80max	80max	120max	120max	80max	80max	120max	120max
		-40 to -20°C *3	120max	120max	150max	150max	120max	120max	150max	150max
	RIPPLE NOISE[mVp-p]	-20 to +55°C *3	120max	120max	150max	150max	120max	120max	150max	150max
		-40 to -20°C *3	200max	200max	200max	200max	200max	200max	200max	200max
	TEMPERATURE REGULATION[mV]	-20 to +55°C	50max	50max	150max	180max	50max	50max	150max	180max
		-40 to +55°C	80max	80max	240max	290max	80max	80max	240max	290max
	DRIFT[mV] *4	20max	20max	48max	60max	20max	20max	48max	60max	
START-UP TIME[ms]	20max (Minimum input, I _o =100%)									
OUTPUT VOLTAGE ADJUSTMENT RANGE	Fixed (TRM pin open) ±5% adjustable by external VR									
OUTPUT VOLTAGE SETTING[V] (±3%)	3.21 - 3.42	4.90 - 5.21	11.64 - 12.36	14.55 - 15.45	3.21 - 3.42	4.90 - 5.21	11.64 - 12.36	14.55 - 15.45		
PROTECTION CIRCUIT AND OTHERS	OVERCURRENT PROTECTION	Works over 105% of rating and recovers automatically								
	REMOTE ON/OFF	Provided (Negative logic L : ON, H : OFF)								

MODEL	SUS10243R3	SUS102405	SUS102412	SUS102415	SUS10483R3	SUS104805	SUS104812	SUS104815
MAX OUTPUT WATTAGE[W]	8.58	10	12	12	8.58	10	12	12
DC OUTPUT	VOLTAGE[V] *1	3.3	5	12	15	3.3	5	12
	CURRENT[A]	2.6	2	1	0.8	2.6	2	1

SPECIFICATIONS

	MODEL	SUS10243R3	SUS102405	SUS102412	SUS102415	SUS10483R3	SUS104805	SUS104812	SUS104815	
INPUT	VOLTAGE[V]	DC18 - 36				DC36 - 76				
	CURRENT[A] *2	0.436typ	0.490typ	0.575typ	0.575typ	0.218typ	0.245typ	0.287typ	0.287typ	
	EFFICIENCY[%] *2	82typ	85typ	87typ	87typ	82typ	85typ	87typ	87typ	
OUTPUT	VOLTAGE[V]	3.3	5	12	15	3.3	5	12	15	
	CURRENT[A]	2.6	2	1	0.8	2.6	2	1	0.8	
	LINE REGULATION[mV]	20max	20max	48max	60max	20max	20max	48max	60max	
	LOAD REGULATION[mV]	40max	40max	100max	120max	40max	40max	100max	120max	
	RIPPLE[mVp-p]	-20 to +55°C *3	80max	80max	120max	120max	80max	80max	120max	120max
		-40 to -20°C *3	120max	120max	150max	150max	120max	120max	150max	150max
	RIPPLE NOISE[mVp-p]	-20 to +55°C *3	120max	120max	150max	150max	120max	120max	150max	150max
		-40 to -20°C *3	200max	200max	200max	200max	200max	200max	200max	200max
	TEMPERATURE REGULATION[mV]	-20 to +55°C	50max	50max	150max	180max	50max	50max	150max	180max
		-40 to +55°C	80max	80max	240max	290max	80max	80max	240max	290max
	DRIFT[mV] *4	20max	20max	48max	60max	20max	20max	48max	60max	
START-UP TIME[ms]	20max (Minimum input, I _o =100%)									
OUTPUT VOLTAGE ADJUSTMENT RANGE	Fixed (TRM pin open) ±5% adjustable by external VR									
OUTPUT VOLTAGE SETTING[V] (±3%)	3.21 - 3.42	4.90 - 5.21	11.64 - 12.36	14.55 - 15.45	3.21 - 3.42	4.90 - 5.21	11.64 - 12.36	14.55 - 15.45		
PROTECTION CIRCUIT AND OTHERS	OVERCURRENT PROTECTION	Works over 105% of rating and recovers automatically								
	REMOTE ON/OFF	Provided (Negative logic L : ON, H : OFF)								

GENERAL SPECIFICATIONS

ISOLATION	INPUT-OUTPUT	AC500V 1minute, Cutoff current = 10mA, DC500V 50MΩ min (20±15°C)
ENVIRONMENT	OPERATING TEMP., HUMID. AND ALTITUDE	-40 to +85°C, 20 - 95%RH (Non condensing) (Refer to "Derating"), 3,000m (10,000feet) max
	STORAGE TEMP., HUMID. AND ALTITUDE	-40 to +100°C, 20 - 95%RH (Non condensing), 9,000m (30,000feet) max
	VIBRATION	10 - 55Hz, 98.0m/s ² (10G), 3minutes period, 60minutes each along X, Y and Z axis
	IMPACT	490.3m/s ² (50G), 11ms, once each along X, Y and Z axis
SAFETY	AGENCY APPROVALS	UL60950-1, C-UL, EN62368-1
OTHERS	CASE SIZE/WEIGHT	39.2×6.5×21.0mm [1.54×0.26×0.83 inches] (W×H×D) / 6g max
	COOLING METHOD	Convection/Forced air

- *1 SUW10xx12/SUW10xx15 is available as single output, +24V/+30V.
- *2 Rated input 5V, 12V, 24V or 48V DC I_o=100%
- *3 Ripple and Ripple Noise is measured by using measuring board with capacitor with in 25mm from output pin terminals.
- *4 Drift is the change in DC output for an eight hour period after a half-hour warm-up at 25°C.
- * Parallel operation with other model is not possible.

External view

1. SMD(type B)

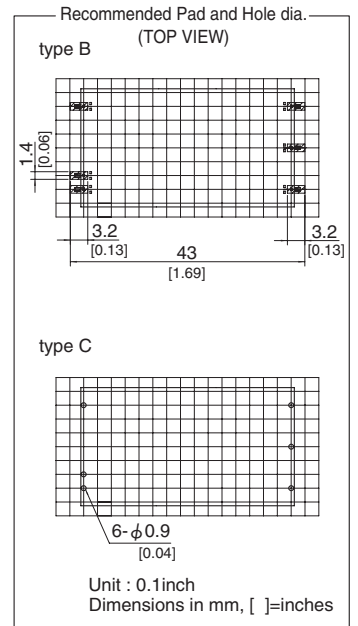
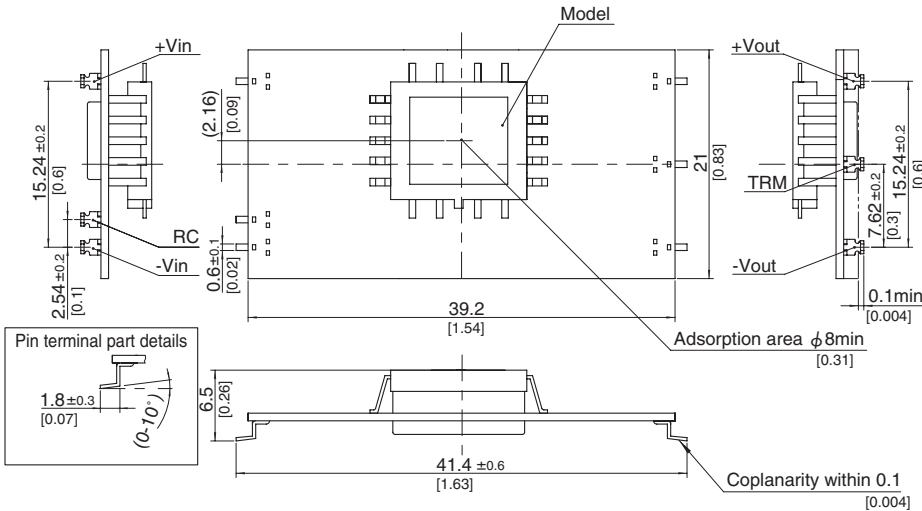

2. DIP(type C)

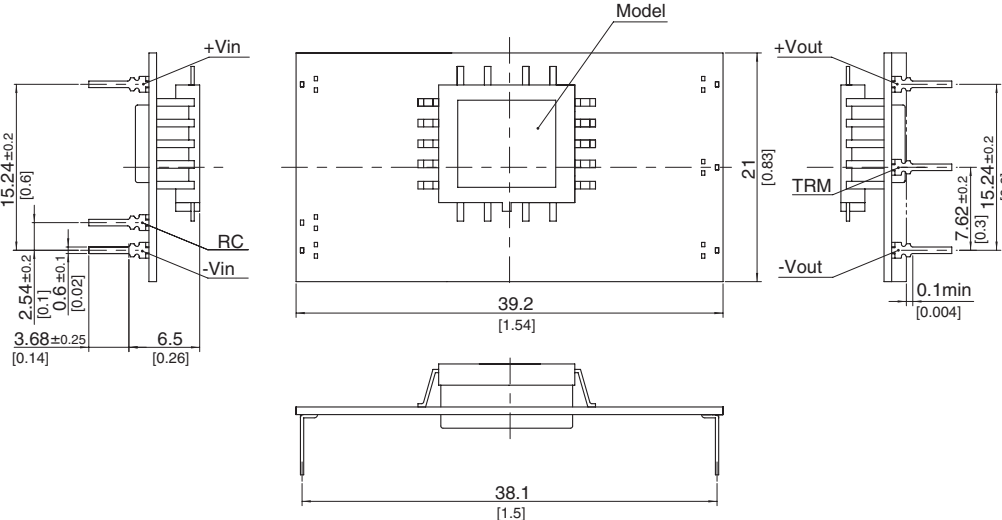

- ※ Tolerance ±0.5 [±0.02]
- ※ Dimensions in mm, []=inches
- ※ Pin terminal thickness : 0.3±0.1 [0.012]
- ※ Pin terminal material : Copper alloy
- ※ Plating treatment of terminal : Lead free plating
- ※ Weight : 6g max

SUW10

SU W 10 12 12 B P - □
 ① ② ③ ④ ⑤ ⑥ ⑦ ⑧



RoHS

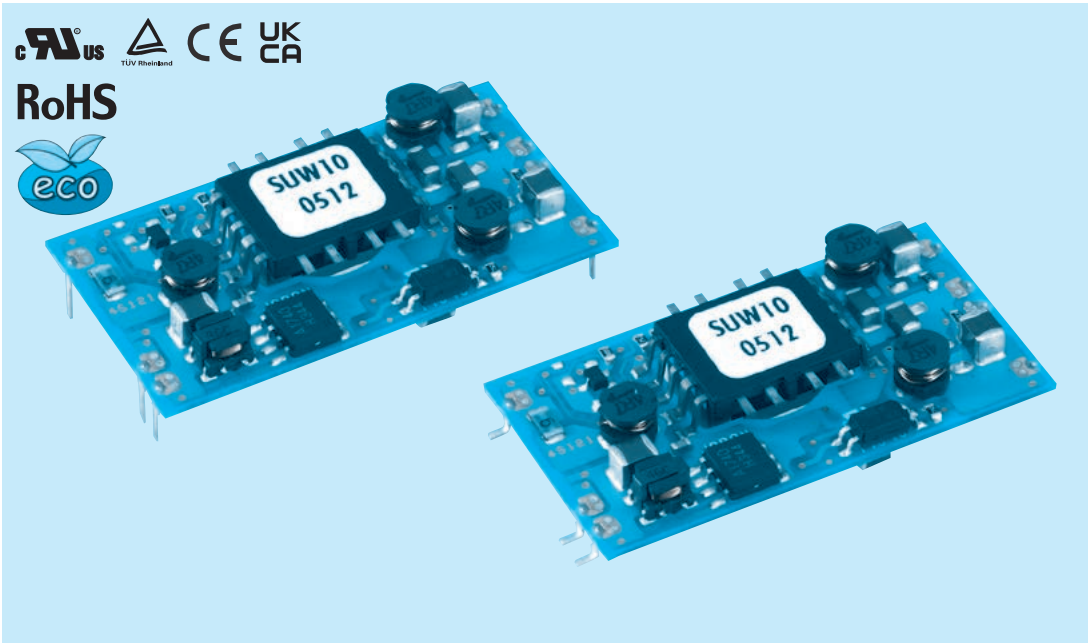

- ① Series name
- ② Dual output
- ③ Output wattage
- ④ Input voltage
- ⑤ Output voltage
- ⑥ Mounting type
B : SMD
C : DIP
- ⑦ Packing form
Blank: Plastic cover
P : Tray(SMD type)
- ⑧ Optional
G : Capacitor between Input and Output is removed.

MODEL	SUW100512	SUW100515	SUW101212	SUW101215	SUW102412	SUW102415	SUW104812	SUW104815	
MAX OUTPUT WATTAGE[W]	10.8	10.5	10.8	10.5	10.8	10.5	10.8	10.5	
DC OUTPUT	VOLTAGE[V] *1	±12 or +24	±15 or +30	±12 or +24	±15 or +30	±12 or +24	±15 or +30	±12 or +24	±15 or +30
	CURRENT[A]	0.45	0.35	0.45	0.35	0.45	0.35	0.45	0.35

SPECIFICATIONS

MODEL	SUW100512	SUW100515	SUW101212	SUW101215	SUW102412	SUW102415	SUW104812	SUW104815		
INPUT	VOLTAGE[V]	DC4.5 - 9		DC9 - 18		DC18 - 36		DC36 - 76		
	CURRENT[A] *2	2.51typ	2.44typ	1.05typ	1.02typ	0.523typ	0.509typ	0.262typ	0.254typ	
	EFFICIENCY[%] *2	86typ	86typ	86typ	86typ	86typ	86typ	86typ	86typ	
OUTPUT	VOLTAGE[V]	±12(+24)	±15(+30)	±12(+24)	±15(+30)	±12(+24)	±15(+30)	±12(+24)	±15(+30)	
	CURRENT[A]	0.45	0.35	0.45	0.35	0.45	0.35	0.45	0.35	
	LINE REGULATION[mV]	60max	75max	60max	75max	60max	75max	60max	75max	
	LOAD REGULATION[mV]	600max	750max	600max	750max	600max	750max	600max	750max	
	RIPPLE[mVp-p]	-20 to +55°C *3	120max	120max	120max	120max	120max	120max	120max	120max
		-40 to -20°C *3	150max	150max	150max	150max	150max	150max	150max	150max
	RIPPLE NOISE[mVp-p]	-20 to +55°C *3	150max	150max	150max	150max	150max	150max	150max	150max
		-40 to -20°C *3	200max	200max	200max	200max	200max	200max	200max	200max
	TEMPERATURE REGULATION[mV]	-20 to +55°C	150max	180max	150max	180max	150max	180max	150max	180max
		-40 to +55°C	240max	290max	240max	290max	240max	290max	240max	290max
DRIFT[mV] *4	50max	60max	50max	60max	50max	60max	50max	60max		
START-UP TIME[ms]	20max (Minimum input, Io=100%)									
OUTPUT VOLTAGE ADJUSTMENT RANGE	Fixed (TRM pin open) ±5% adjustable by external VR									
OUTPUT VOLTAGE SETTING[V] (±5%)	11.40 - 12.60	14.25 - 15.75	11.40 - 12.60	14.25 - 15.75	11.40 - 12.60	14.25 - 15.75	11.40 - 12.60	14.25 - 15.75		
PROTECTION CIRCUIT AND OTHERS	OVERCURRENT PROTECTION	Works over 105% of rating and recovers automatically								
	REMOTE ON/OFF	Provided (Negative logic L : ON, H : OFF)								
ISOLATION	INPUT-OUTPUT	AC500V 1minute. Cutoff current = 10mA. DC500V 50MΩ min (20±15°C)								
ENVIRONMENT	OPERATING TEMP., HUMID. AND ALTITUDE	-40 to +85°C, 20 - 95%RH (Non condensing) (Refer to "Derating"), 3,000m (10,000feet) max								
	STORAGE TEMP., HUMID. AND ALTITUDE	-40 to +100°C, 20 - 95%RH (Non condensing), 9,000m (30,000feet) max								
	VIBRATION	10 - 55Hz, 98.0m/s ² (10G), 3minutes period, 60minutes each along X, Y and Z axis								
	IMPACT	490.3m/s ² (50G), 11ms. once each along X, Y and Z axis								
SAFETY	AGENCY APPROVALS	UL60950-1, C-UL, EN62368-1								
OTHERS	CASE SIZE/WEIGHT	39.2 × 6.5 × 21.0mm [1.54 × 0.26 × 0.83 inches] (W × H × D) / 6g max								
	COOLING METHOD	Convection/Forced air								

*1 Output pins can be connected in series to make a 24V/30V output.
 *2 Rated input 5V, 12V, 24V or 48V DC Io=100%
 *3 Ripple and Ripple Noise is measured by using measuring board with capacitor with in 25mm from output pin terminals.
 *4 Drift is the change in DC output for an eight hour period after a half-hour warm-up at 25°C.
 * Parallel operation with other model is not possible.

External view

1.SMD(type B)

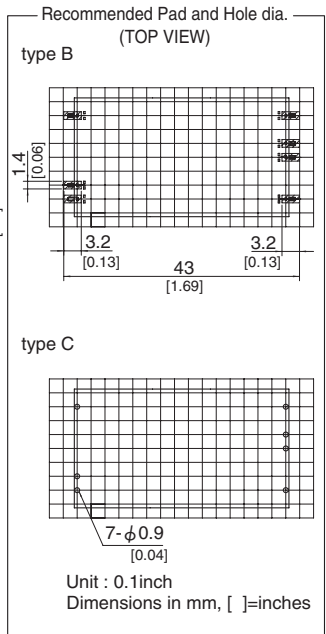
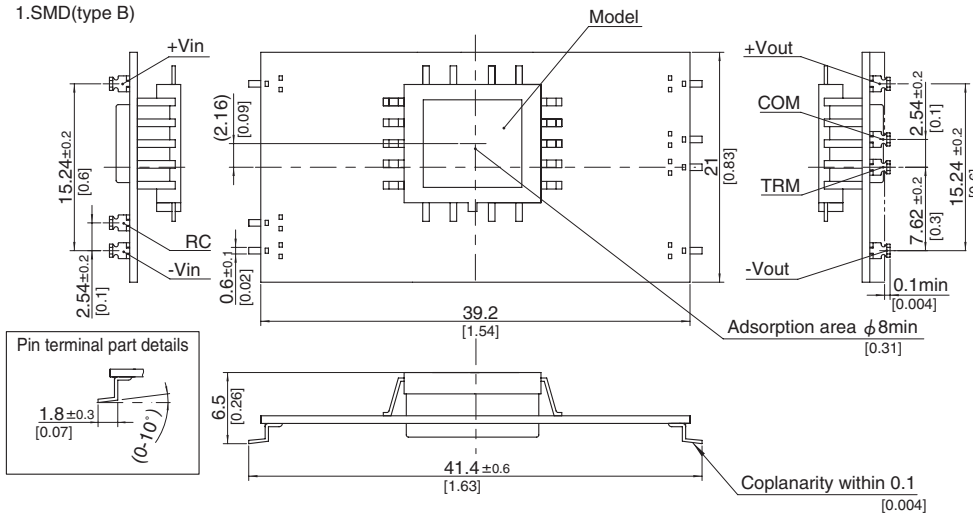

2.DIP(type C)

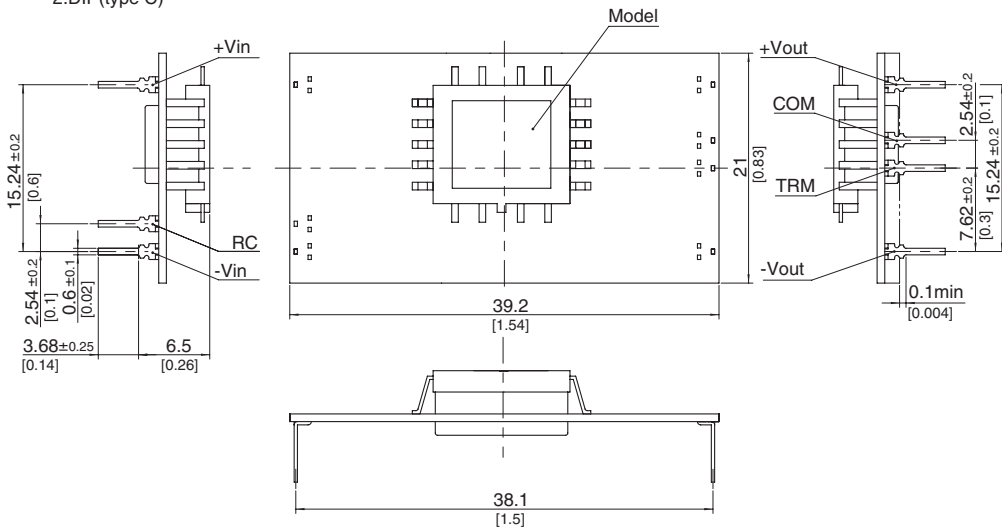

- ※ Tolerance ± 0.5 [± 0.02]
- ※ Dimensions in mm, []=inches
- ※ Pin terminal thickness : 0.3 ± 0.1 [0.012]
- ※ Pin terminal material : Copper alloy
- ※ Plating treatment of terminal : Lead free plating
- ※ Weight : 6g max

SUCS1R5

SUC S 1R5 12 05 B P - □

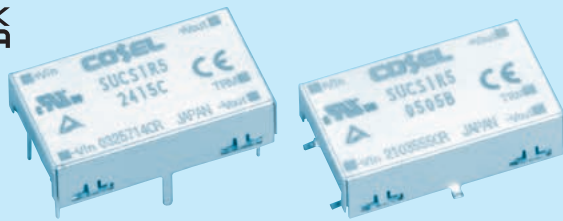
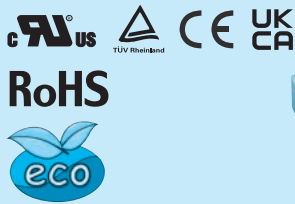

- ① Series name
 - ② Single output
 - ③ Output wattage
 - ④ Input voltage
 - ⑤ Output voltage
 - ⑥ Mounting type
B :SMD
C :DIP
 - ⑦ Packing form
Blank:Plastic cover
P :Tray (SMD type)
 - ⑧ Optional
C :with coating (only DIP type)*
- *Safety standards are pending

MODEL	SUCS1R5053R3	SUCS1R50505	SUCS1R50512	SUCS1R50515	SUCS1R5123R3	SUCS1R51205	SUCS1R51212	SUCS1R51215
MAX OUTPUT WATTAGE[W]	1.32	1.5	1.56	1.5	1.32	1.5	1.56	1.5
DC OUTPUT	VOLTAGE[V] *1	3.3	5	12	15	3.3	5	12
	CURRENT[A]	0.4	0.3	0.13	0.1	0.4	0.3	0.13

SPECIFICATIONS

	MODEL	SUCS1R5053R3	SUCS1R50505	SUCS1R50512	SUCS1R50515	SUCS1R5123R3	SUCS1R51205	SUCS1R51212	SUCS1R51215	
INPUT	VOLTAGE[V]	DC4.5 - 9				DC9 - 18				
	CURRENT[A] *2	0.388typ	0.417typ	0.433typ	0.417typ	0.157typ	0.169typ	0.176typ	0.169typ	
	EFFICIENCY[%] *2	68typ	72typ	72typ	72typ	70typ	74typ	74typ	74typ	
OUTPUT	VOLTAGE[V]	3.3	5	12	15	3.3	5	12	15	
	CURRENT[A]	0.4	0.3	0.13	0.1	0.4	0.3	0.13	0.1	
	LINE REGULATION[mV]	20max	20max	48max	60max	20max	20max	48max	60max	
	LOAD REGULATION[mV]	40max	40max	100max	120max	40max	40max	100max	120max	
	RIPPLE[mVp-p]	-20 to +55°C *3	80max	80max	120max	120max	80max	80max	120max	120max
		-40 to -20°C *3	120max	120max	150max	150max	120max	120max	150max	150max
	RIPPLE NOISE[mVp-p]	-20 to +55°C *3	120max	120max	150max	150max	120max	120max	150max	150max
		-40 to -20°C *3	200max	200max	200max	200max	200max	200max	200max	200max
	TEMPERATURE REGULATION[mV]	-20 to +55°C	50max	50max	150max	180max	50max	50max	150max	180max
		-40 to +55°C	80max	80max	240max	290max	80max	80max	240max	290max
DRIFT[mV] *4	20max	20max	48max	60max	20max	20max	48max	60max		
START-UP TIME[ms]	20max (Minimum input, Io=100%)									
OUTPUT VOLTAGE ADJUSTMENT RANGE	Fixed (TRM pin open) ±5% adjustable by external VR									
OUTPUT VOLTAGE SETTING[V] (±3%)	3.21 - 3.42	4.90 - 5.21	11.64 - 12.36	14.55 - 15.45	3.21 - 3.42	4.90 - 5.21	11.64 - 12.36	14.55 - 15.45		
OVERCURRENT PROTECTION	Works over 105% of rating and recovers automatically									

MODEL	SUCS1R5243R3	SUCS1R52405	SUCS1R52412	SUCS1R52415	SUCS1R5483R3	SUCS1R54805	SUCS1R54812	SUCS1R54815
MAX OUTPUT WATTAGE[W]	1.32	1.5	1.56	1.5	1.32	1.5	1.56	1.5
DC OUTPUT	VOLTAGE[V] *1	3.3	5	12	15	3.3	5	12
	CURRENT[A]	0.4	0.3	0.13	0.1	0.4	0.3	0.13

SPECIFICATIONS

	MODEL	SUCS1R5243R3	SUCS1R52405	SUCS1R52412	SUCS1R52415	SUCS1R5483R3	SUCS1R54805	SUCS1R54812	SUCS1R54815	
INPUT	VOLTAGE[V]	DC18 - 36				DC36 - 76				
	CURRENT[A] *2	0.079typ	0.084typ	0.087typ	0.083typ	0.039typ	0.042typ	0.043typ	0.042typ	
	EFFICIENCY[%] *2	70typ	74typ	75typ	75typ	70typ	74typ	75typ	75typ	
OUTPUT	VOLTAGE[V]	3.3	5	12	15	3.3	5	12	15	
	CURRENT[A]	0.4	0.3	0.13	0.1	0.4	0.3	0.13	0.1	
	LINE REGULATION[mV]	20max	20max	48max	60max	20max	20max	48max	60max	
	LOAD REGULATION[mV]	40max	40max	100max	120max	40max	40max	100max	120max	
	RIPPLE[mVp-p]	-20 to +55°C *3	80max	80max	120max	120max	80max	80max	120max	120max
		-40 to -20°C *3	120max	120max	150max	150max	120max	120max	150max	150max
	RIPPLE NOISE[mVp-p]	-20 to +55°C *3	120max	120max	150max	150max	120max	120max	150max	150max
		-40 to -20°C *3	200max	200max	200max	200max	200max	200max	200max	200max
	TEMPERATURE REGULATION[mV]	-20 to +55°C	50max	50max	150max	180max	50max	50max	150max	180max
		-40 to +55°C	80max	80max	240max	290max	80max	80max	240max	290max
DRIFT[mV] *4	20max	20max	48max	60max	20max	20max	48max	60max		
START-UP TIME[ms]	20max (Minimum input, Io=100%)									
OUTPUT VOLTAGE ADJUSTMENT RANGE	Fixed (TRM pin open) ±5% adjustable by external VR									
OUTPUT VOLTAGE SETTING[V] (±3%)	3.21 - 3.42	4.90 - 5.21	11.64 - 12.36	14.55 - 15.45	3.21 - 3.42	4.90 - 5.21	11.64 - 12.36	14.55 - 15.45		
OVERCURRENT PROTECTION	Works over 105% of rating and recovers automatically									

GENERAL SPECIFICATIONS

ISOLATION	INPUT-OUTPUT	AC500V 1minute, Cutoff current = 10mA, DC500V 50M Ω min (20 \pm 15 $^{\circ}$ C)
	INPUT-CASE	AC500V 1minute, Cutoff current = 10mA, DC500V 50M Ω min (20 \pm 15 $^{\circ}$ C)
	OUTPUT-CASE	AC500V 1minute, Cutoff current = 10mA, DC500V 50M Ω min (20 \pm 15 $^{\circ}$ C)
ENVIRONMENT	OPERATING TEMP., HUMID. AND ALTITUDE	-40 to +85 $^{\circ}$ C, 20 - 95%RH (Non condensing) (Refer to "Derating"), 3,000m (10,000feet) max
	STORAGE TEMP., HUMID. AND ALTITUDE	-40 to +100 $^{\circ}$ C, 20 - 95%RH (Non condensing), 9,000m (30,000feet) max
	VIBRATION	10 - 55Hz, 98.0m/s 2 (10G), 3minutes period, 60minutes each along X, Y and Z axis
	IMPACT	490.3m/s 2 (50G), 11ms, once each along X, Y and Z axis
SAFETY	AGENCY APPROVALS	UL60950-1, C-UL, EN62368-1
OTHERS	CASE SIZE/WEIGHT	22.4 x 7.0 x 13.2mm [0.88 x 0.28 x 0.52 inches] (W x H x D) / 3g max
	COOLING METHOD	Convection/Forced air

- *1 SUCW1R5xx12/SUCW1R5xx15 is available as single output, +24V/+30V.
- *2 Rated input 5V, 12V, 24V or 48V DC I_o=100%
- *3 Ripple and Ripple Noise is measured by using measuring board with capacitor with in 25mm from output pin terminals.
- *4 Drift is the change in DC output for an eight hour period after a half-hour warm-up at 25 $^{\circ}$ C.
- * Parallel operation with other model is not possible.

External view

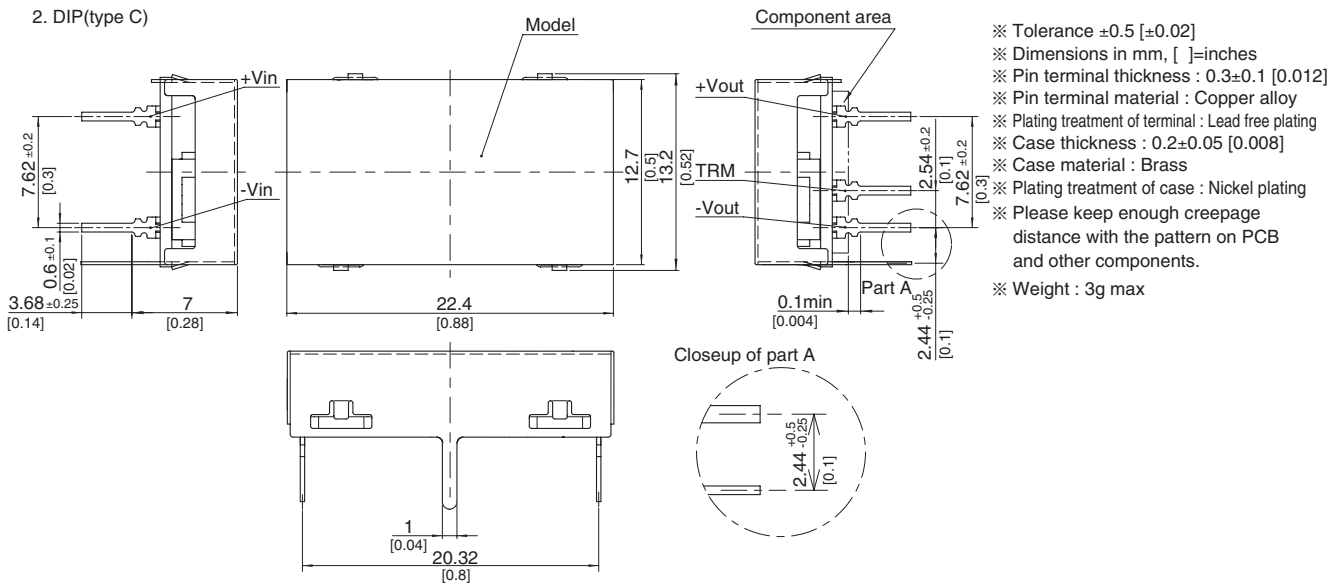
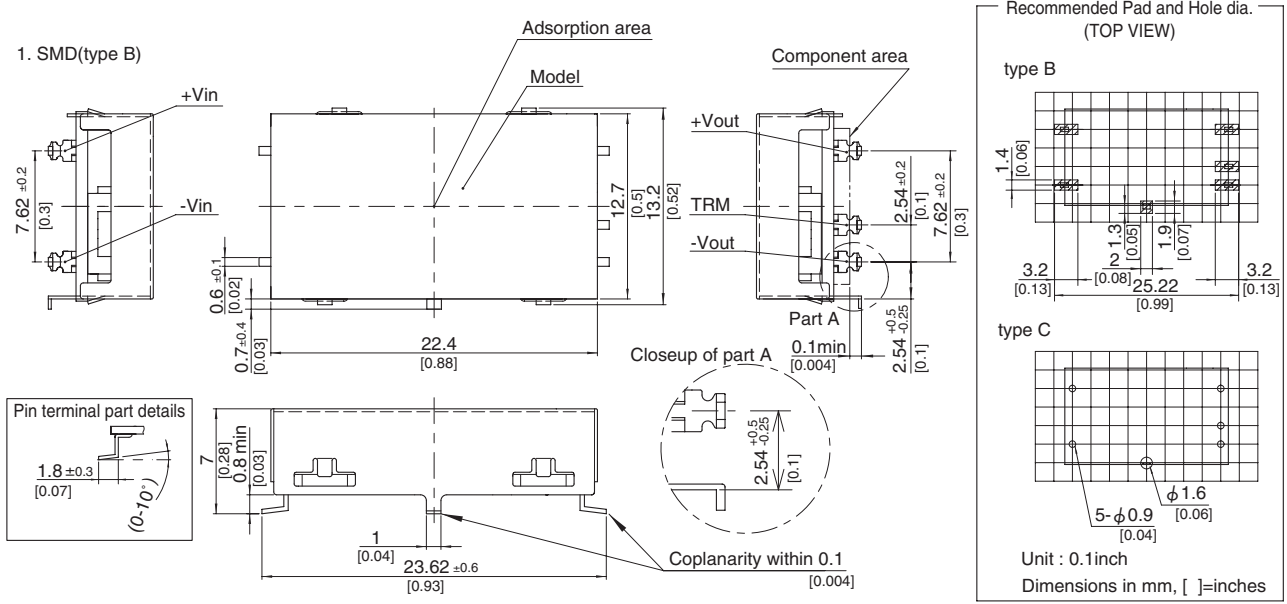

SUCW1R5

SUC W 1R5 12 12 B P -□

① ② ③ ④ ⑤ ⑥ ⑦ ⑧

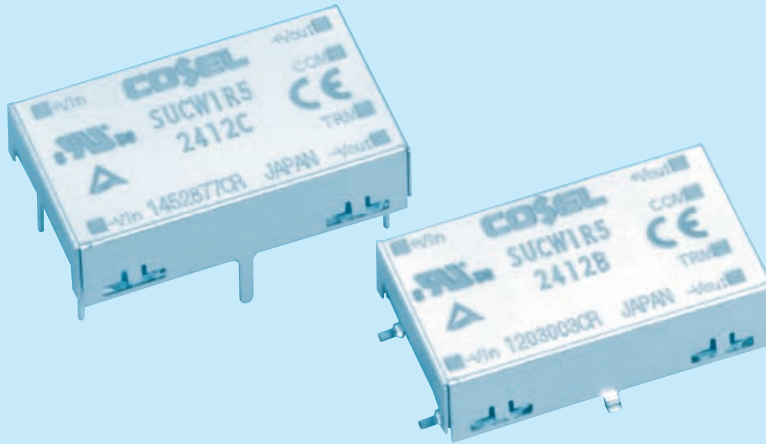

- ① Series name
 - ② Dual output
 - ③ Output wattage
 - ④ Input voltage
 - ⑤ Output voltage
 - ⑥ Mounting type
B : SMD
C : DIP
 - ⑦ Packing form
Blank: Plastic cover
P : Tray (SMD type)
 - ⑧ Optional
C : with coating (only DIP type)*
- * Safety standards are pending

MODEL	SUCW1R50512	SUCW1R50515	SUCW1R51212	SUCW1R51215	SUCW1R52412	SUCW1R52415	SUCW1R54812	SUCW1R54815	
MAX OUTPUT WATTAGE[W]	1.56	1.5	1.56	1.5	1.56	1.5	1.56	1.5	
DC OUTPUT	VOLTAGE[V] *1	± 12 or +24	± 15 or +30	± 12 or +24	± 15 or +30	± 12 or +24	± 15 or +30	± 12 or +24	± 15 or +30
	CURRENT[A]	0.065	0.05	0.065	0.05	0.065	0.05	0.065	0.05

SPECIFICATIONS

	MODEL	SUCW1R50512	SUCW1R50515	SUCW1R51212	SUCW1R51215	SUCW1R52412	SUCW1R52415	SUCW1R54812	SUCW1R54815	
INPUT	VOLTAGE[V]	DC4.5 - 9		DC9 - 18		DC18 - 36		DC36 - 76		
	CURRENT[A] *2	0.446typ	0.429typ	0.178typ	0.171typ	0.089typ	0.086typ	0.045typ	0.043typ	
	EFFICIENCY[%] *2	70typ	70typ	73typ	73typ	73typ	73typ	73typ	73typ	
OUTPUT	VOLTAGE[V]	± 12(+24)	± 15(+30)	± 12(+24)	± 15(+30)	± 12(+24)	± 15(+30)	± 12(+24)	± 15(+30)	
	CURRENT[A]	0.065	0.05	0.065	0.05	0.065	0.05	0.065	0.05	
	LINE REGULATION[mV]	60max	75max	60max	75max	60max	75max	60max	75max	
	LOAD REGULATION[mV]	600max	750max	600max	750max	600max	750max	600max	750max	
	RIPPLE[mVp-p]	-20 to +55°C *3	120max	120max	120max	120max	120max	120max	120max	120max
		-40 to -20°C *3	150max	150max	150max	150max	150max	150max	150max	150max
	RIPPLE NOISE[mVp-p]	-20 to +55°C *3	150max	150max	150max	150max	150max	150max	150max	150max
		-40 to -20°C *3	200max	200max	200max	200max	200max	200max	200max	200max
	TEMPERATURE REGULATION[mV]	-20 to +55°C	150max	180max	150max	180max	150max	180max	150max	180max
		-40 to +55°C	240max	290max	240max	290max	240max	290max	240max	290max
DRIFT[mV] *4	50max	60max	50max	60max	50max	60max	50max	60max		
START-UP TIME[ms]	20max (Minimum input, I _o =100%)									
OUTPUT VOLTAGE ADJUSTMENT RANGE	Fixed (TRM pin open) ±5% adjustable by external VR									
OUTPUT VOLTAGE SETTING[V] (±5%)	11.40 - 12.60	14.25 - 15.75	11.40 - 12.60	14.25 - 15.75	11.40 - 12.60	14.25 - 15.75	11.40 - 12.60	14.25 - 15.75		
PROTECTION CIRCUIT AND OTHERS	OVERCURRENT PROTECTION	Works over 105% of rating and recovers automatically								
ISOLATION	INPUT-OUTPUT	AC500V 1minute, Cutoff current = 10mA, DC500V 50MΩ min (20±15°C)								
	INPUT-CASE	AC500V 1minute, Cutoff current = 10mA, DC500V 50MΩ min (20±15°C)								
	OUTPUT-CASE	AC500V 1minute, Cutoff current = 10mA, DC500V 50MΩ min (20±15°C)								
ENVIRONMENT	OPERATING TEMP., HUMID. AND ALTITUDE	-40 to +85°C, 20 - 95%RH (Non condensing) (Refer to "Derating"), 3,000m (10,000feet) max								
	STORAGE TEMP., HUMID. AND ALTITUDE	-40 to +100°C, 20 - 95%RH (Non condensing), 9,000m (30,000feet) max								
	VIBRATION	10 - 55Hz, 98.0m/s ² (10G), 3minutes period, 60minutes each along X, Y and Z axis								
	IMPACT	490.3m/s ² (50G), 11ms, once each along X, Y and Z axis								
SAFETY	AGENCY APPROVALS	UL60950-1, C-UL, EN62368-1								
OTHERS	CASE SIZE/WEIGHT	22.4 × 7.0 × 13.2mm [0.88 × 0.28 × 0.52 inches] (W × H × D) / 3g max								
	COOLING METHOD	Convection/Forced air								

*1 Output pins can be connected in series to make a 24V/30V output.
 *2 Rated input 5V, 12V, 24V or 48V DC I_o=100%
 *3 Ripple and Ripple Noise is measured by using measuring board with capacitor with in 25mm from output pin terminals.
 *4 Drift is the change in DC output for an eight hour period after a half-hour warm-up at 25°C.
 * Parallel operation with other model is not possible.

SUCS3

SUC S 3 12 05 B P - □

① ② ③ ④ ⑤ ⑥ ⑦ ⑧

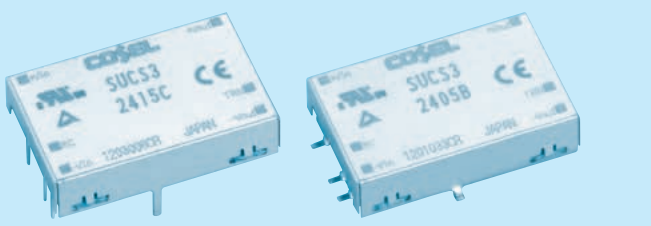

- ① Series name
- ② Single output
- ③ Output wattage
- ④ Input voltage
- ⑤ Output voltage
- ⑥ Mounting type
B :SMD
C :DIP
- ⑦ Packing form
Blank:Plastic cover
P :Tray (SMD type)
- ⑧ Optional
G :Capacitor between Input and Output is removed.
C :with coating (only DIP type)*
* Safety standards are pending

MODEL	SUCS3053R3	SUCS30505	SUCS30512	SUCS30515	SUCS3123R3	SUCS31205	SUCS31212	SUCS31215	
MAX OUTPUT WATTAGE[W]	1.98	3	3	3	1.98	3	3	3	
DC OUTPUT	VOLTAGE[V] *1	3.3	5	12	15	3.3	5	12	15
	CURRENT[A]	0.6	0.6	0.25	0.2	0.6	0.6	0.25	0.2

SPECIFICATIONS

	MODEL	SUCS3053R3	SUCS30505	SUCS30512	SUCS30515	SUCS3123R3	SUCS31205	SUCS31212	SUCS31215	
INPUT	VOLTAGE[V]	DC4.5 - 9				DC9 - 18				
	CURRENT[A] *2	0.550typ	0.800typ	0.780typ	0.780typ	0.223typ	0.325typ	0.317typ	0.321typ	
	EFFICIENCY[%] *2	72typ	75typ	77typ	77typ	74typ	77typ	79typ	78typ	
OUTPUT	VOLTAGE[V]	3.3	5	12	15	3.3	5	12	15	
	CURRENT[A]	0.6	0.6	0.25	0.2	0.6	0.6	0.25	0.2	
	LINE REGULATION[mV]	20max	20max	48max	60max	20max	20max	48max	60max	
	LOAD REGULATION[mV]	40max	40max	100max	120max	40max	40max	100max	120max	
	RIPPLE[mVp-p]	-20 to +55°C *3	80max	80max	120max	120max	80max	80max	120max	120max
		-40 to -20°C *3	120max	120max	150max	150max	120max	120max	150max	150max
	RIPPLE NOISE[mVp-p]	-20 to +55°C *3	120max	120max	150max	150max	120max	120max	150max	150max
		-40 to -20°C *3	200max	200max	200max	200max	200max	200max	200max	200max
	TEMPERATURE REGULATION[mV]	-20 to +55°C	50max	50max	150max	180max	50max	50max	150max	180max
		-40 to +55°C	80max	80max	240max	290max	80max	80max	240max	290max
DRIFT[mV] *4	20max	20max	48max	60max	20max	20max	48max	60max		
START-UP TIME[ms]	20max (Minimum input, Io=100%)									
OUTPUT VOLTAGE ADJUSTMENT RANGE	Fixed (TRM pin open) ±5% adjustable by external VR									
OUTPUT VOLTAGE SETTING[V] (±3%)	3.21 - 3.42	4.90 - 5.21	11.64 - 12.36	14.55 - 15.45	3.21 - 3.42	4.90 - 5.21	11.64 - 12.36	14.55 - 15.45		
PROTECTION CIRCUIT AND OTHERS	OVERCURRENT PROTECTION	Works over 105% of rating and recovers automatically								
	REMOTE ON/OFF	Provided (Negative logic L : ON, H : OFF)								

MODEL	SUCS3243R3	SUCS32405	SUCS32412	SUCS32415	SUCS3483R3	SUCS34805	SUCS34812	SUCS34815	
MAX OUTPUT WATTAGE[W]	1.98	3	3	3	1.98	3	3	3	
DC OUTPUT	VOLTAGE[V] *1	3.3	5	12	15	3.3	5	12	15
	CURRENT[A]	0.6	0.6	0.25	0.2	0.6	0.6	0.25	0.2

SPECIFICATIONS

	MODEL	SUCS3243R3	SUCS32405	SUCS32412	SUCS32415	SUCS3483R3	SUCS34805	SUCS34812	SUCS34815	
INPUT	VOLTAGE[V]	DC18 - 36				DC36 - 76				
	CURRENT[A] *2	0.114typ	0.163typ	0.159typ	0.161typ	0.057typ	0.082typ	0.080typ	0.080typ	
	EFFICIENCY[%] *2	73typ	77typ	79typ	78typ	72typ	77typ	79typ	79typ	
OUTPUT	VOLTAGE[V]	3.3	5	12	15	3.3	5	12	15	
	CURRENT[A]	0.6	0.6	0.25	0.2	0.6	0.6	0.25	0.2	
	LINE REGULATION[mV]	20max	20max	48max	60max	20max	20max	48max	60max	
	LOAD REGULATION[mV]	40max	40max	100max	120max	40max	40max	100max	120max	
	RIPPLE[mVp-p]	-20 to +55°C *3	80max	80max	120max	120max	80max	80max	120max	120max
		-40 to -20°C *3	120max	120max	150max	150max	120max	120max	150max	150max
	RIPPLE NOISE[mVp-p]	-20 to +55°C *3	120max	120max	150max	150max	120max	120max	150max	150max
		-40 to -20°C *3	200max	200max	200max	200max	200max	200max	200max	200max
	TEMPERATURE REGULATION[mV]	-20 to +55°C	50max	50max	150max	180max	50max	50max	150max	180max
		-40 to +55°C	80max	80max	240max	290max	80max	80max	240max	290max
DRIFT[mV] *4	20max	20max	48max	60max	20max	20max	48max	60max		
START-UP TIME[ms]	20max (Minimum input, Io=100%)									
OUTPUT VOLTAGE ADJUSTMENT RANGE	Fixed (TRM pin open) ±5% adjustable by external VR									
OUTPUT VOLTAGE SETTING[V] (±3%)	3.21 - 3.42	4.90 - 5.21	11.64 - 12.36	14.55 - 15.45	3.21 - 3.42	4.90 - 5.21	11.64 - 12.36	14.55 - 15.45		
PROTECTION CIRCUIT AND OTHERS	OVERCURRENT PROTECTION	Works over 105% of rating and recovers automatically								
	REMOTE ON/OFF	Provided (Negative logic L : ON, H : OFF)								

GENERAL SPECIFICATIONS

ISOLATION	INPUT-OUTPUT	AC500V 1minute, Cutoff current = 10mA, DC500V 50MΩ min (20±15°C)
	INPUT-CASE	AC500V 1minute, Cutoff current = 10mA, DC500V 50MΩ min (20±15°C)
	OUTPUT-CASE	AC500V 1minute, Cutoff current = 10mA, DC500V 50MΩ min (20±15°C)
ENVIRONMENT	OPERATING TEMP., HUMID. AND ALTITUDE	-40 to +85°C, 20 - 95%RH (Non condensing) (Refer to "Derating"), 3,000m (10,000feet) max
	STORAGE TEMP., HUMID. AND ALTITUDE	-40 to +100°C, 20 - 95%RH (Non condensing), 9,000m (30,000feet) max
	VIBRATION	10 - 55Hz, 98.0m/s ² (10G), 3minutes period, 60minutes each along X, Y and Z axis
	IMPACT	490.3m/s ² (50G), 11ms, once each along X, Y and Z axis
SAFETY	AGENCY APPROVALS	UL60950-1, C-UL, EN62368-1
OTHERS	CASE SIZE/WEIGHT	25 x 7.0 x 16.1mm [0.98 x 0.28 x 0.63 inches] (W x H x D) / 5g max
	COOLING METHOD	Convection/Forced air

- *1 SUCW3xx12/SUCW3xx15 is available as single output, +24V/+30V.
- *2 Rated input 5V, 12V, 24V or 48V DC Io=100%
- *3 Ripple and Ripple Noise is measured by using measuring board with capacitor with in 25mm from output pin terminals.
- *4 Drift is the change in DC output for an eight hour period after a half-hour warm-up at 25°C.
- * Parallel operation with other model is not possible.

External view

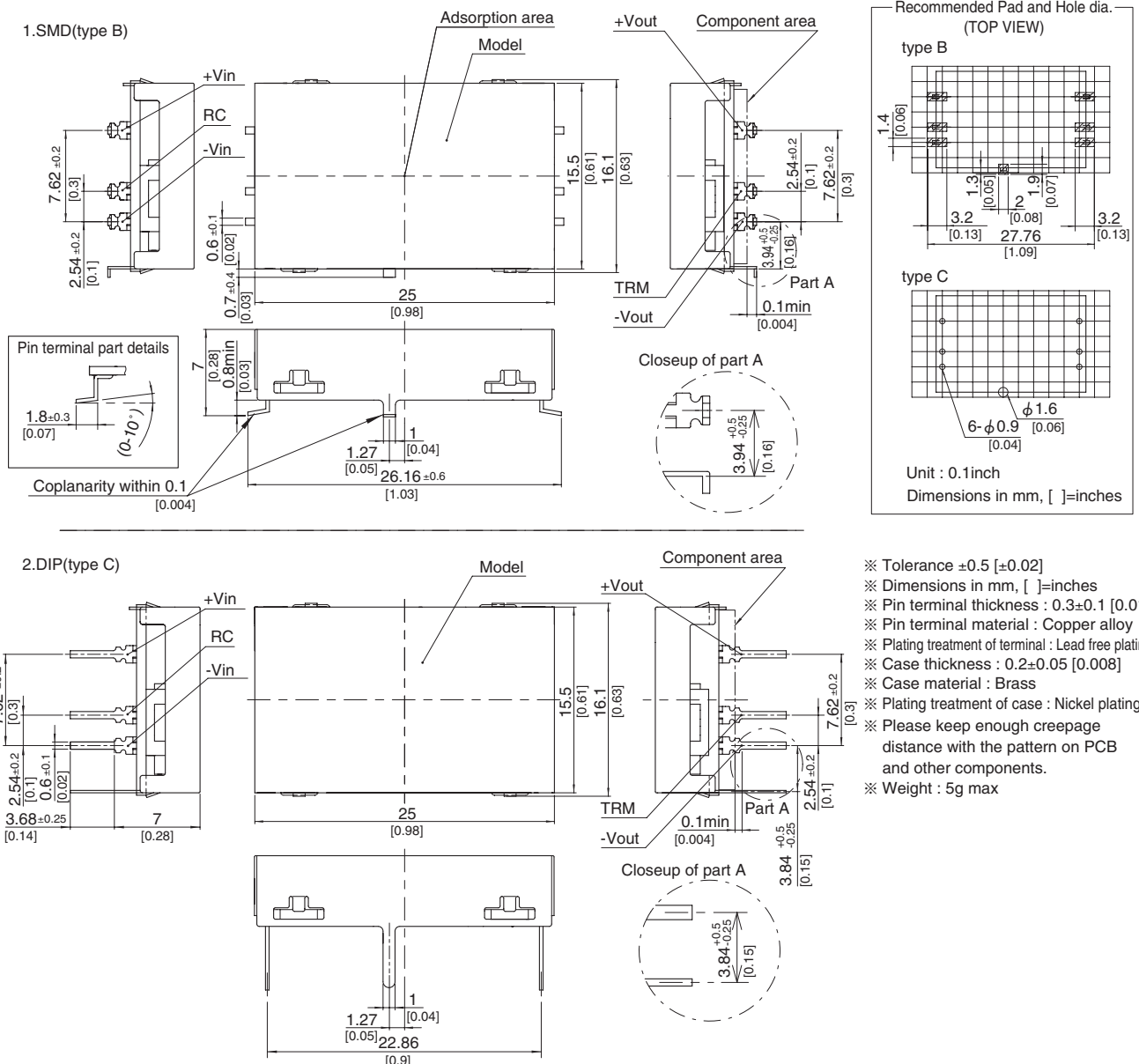

SUCW3

SUC W 3 12 12 B P - □

① ② ③ ④ ⑤ ⑥ ⑦ ⑧

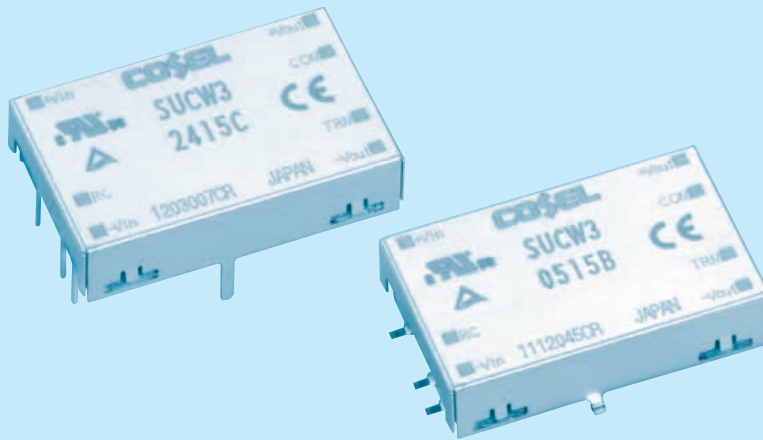

- ① Series name
 - ② Dual output
 - ③ Output wattage
 - ④ Input voltage
 - ⑤ Output voltage
 - ⑥ Mounting type
B : SMD
C : DIP
 - ⑦ Packing form
Blank: Plastic cover
P : Tray (SMD type)
 - ⑧ Optional
G : Capacitor between Input and Output is removed.
C : with coating (only DIP type)*
- * Safety standards are pending

MODEL	SUCW30512	SUCW30515	SUCW31212	SUCW31215	SUCW32412	SUCW32415	SUCW34812	SUCW34815	
MAX OUTPUT WATTAGE[W]	3.12	3	3.12	3	3.12	3	3.12	3	
DC OUTPUT	VOLTAGE[V]*1	±12 or +24	±15 or +30	±12 or +24	±15 or +30	±12 or +24	±15 or +30	±12 or +24	±15 or +30
	CURRENT[A]	0.13	0.1	0.13	0.1	0.13	0.1	0.13	0.1

SPECIFICATIONS

	MODEL	SUCW30512	SUCW30515	SUCW31212	SUCW31215	SUCW32412	SUCW32415	SUCW34812	SUCW34815	
INPUT	VOLTAGE[V]	DC4.5 - 9		DC9 - 18		DC18 - 36		DC36 - 76		
	CURRENT[A]	*2 0.844typ	0.811typ	0.343typ	0.329typ	0.172typ	0.165typ	0.086typ	0.083typ	
	EFFICIENCY[%]	*2 74typ	74typ	76typ	76typ	76typ	76typ	76typ	76typ	
OUTPUT	VOLTAGE[V]	±12(+24)	±15(+30)	±12(+24)	±15(+30)	±12(+24)	±15(+30)	±12(+24)	±15(+30)	
	CURRENT[A]	0.13	0.1	0.13	0.1	0.13	0.1	0.13	0.1	
	LINE REGULATION[mV]	60max	75max	60max	75max	60max	75max	60max	75max	
	LOAD REGULATION[mV]	600max	750max	600max	750max	600max	750max	600max	750max	
	RIPPLE[mVp-p]	-20 to +55°C *3	120max	120max	120max	120max	120max	120max	120max	120max
		-40 to -20°C *3	150max	150max	150max	150max	150max	150max	150max	150max
	RIPPLE NOISE[mVp-p]	-20 to +55°C *3	150max	150max	150max	150max	150max	150max	150max	150max
		-40 to -20°C *3	200max	200max	200max	200max	200max	200max	200max	200max
	TEMPERATURE REGULATION[mV]	-20 to +55°C	150max	180max	150max	180max	150max	180max	150max	180max
		-40 to +55°C	240max	290max	240max	290max	240max	290max	240max	290max
DRIFT[mV]	*4 50max	60max	50max	60max	50max	60max	50max	60max		
START-UP TIME[ms]	20max (Minimum input, Io=100%)									
OUTPUT VOLTAGE ADJUSTMENT RANGE	Fixed (TRM pin open) ±5% adjustable by external VR									
OUTPUT VOLTAGE SETTING[V] (±5%)	11.40 - 12.60	14.25 - 15.75	11.40 - 12.60	14.25 - 15.75	11.40 - 12.60	14.25 - 15.75	11.40 - 12.60	14.25 - 15.75	11.40 - 12.60	
PROTECTION CIRCUIT AND OTHERS	OVERCURRENT PROTECTION	Works over 105% of rating and recovers automatically								
	REMOTE ON/OFF	Provided (Negative logic L : ON, H : OFF)								
ISOLATION	INPUT-OUTPUT	AC500V 1minute, Cutoff current = 10mA, DC500V 50MΩ min (20±15°C)								
	INPUT-CASE	AC500V 1minute, Cutoff current = 10mA, DC500V 50MΩ min (20±15°C)								
	OUTPUT-CASE	AC500V 1minute, Cutoff current = 10mA, DC500V 50MΩ min (20±15°C)								
ENVIRONMENT	OPERATING TEMP., HUMID. AND ALTITUDE	-40 to +85°C, 20 - 95%RH (Non condensing) (Refer to "Derating"), 3,000m (10,000feet) max								
	STORAGE TEMP., HUMID. AND ALTITUDE	-40 to +100°C, 20 - 95%RH (Non condensing), 9,000m (30,000feet) max								
	VIBRATION	10 - 55Hz, 98.0m/s ² (10G), 3minutes period, 60minutes each along X, Y and Z axis								
	IMPACT	490.3m/s ² (50G), 11ms, once each along X, Y and Z axis								
SAFETY	AGENCY APPROVALS	UL60950-1, C-UL, EN62368-1								
OTHERS	CASE SIZE/WEIGHT	25 × 7.0 × 16.1mm [0.98 × 0.28 × 0.63 inches] (W × H × D) / 5g max								
	COOLING METHOD	Convection/Forced air								

*1 Output pins can be connected in series to make a 24V/30V output.
 *2 Rated input 5V, 12V, 24V or 48V DC Io=100%
 *3 Ripple and Ripple Noise is measured by using measuring board with capacitor with in 25mm from output pin terminals.
 *4 Drift is the change in DC output for an eight hour period after a half-hour warm-up at 25°C.
 * Parallel operation with other model is not possible.

External view

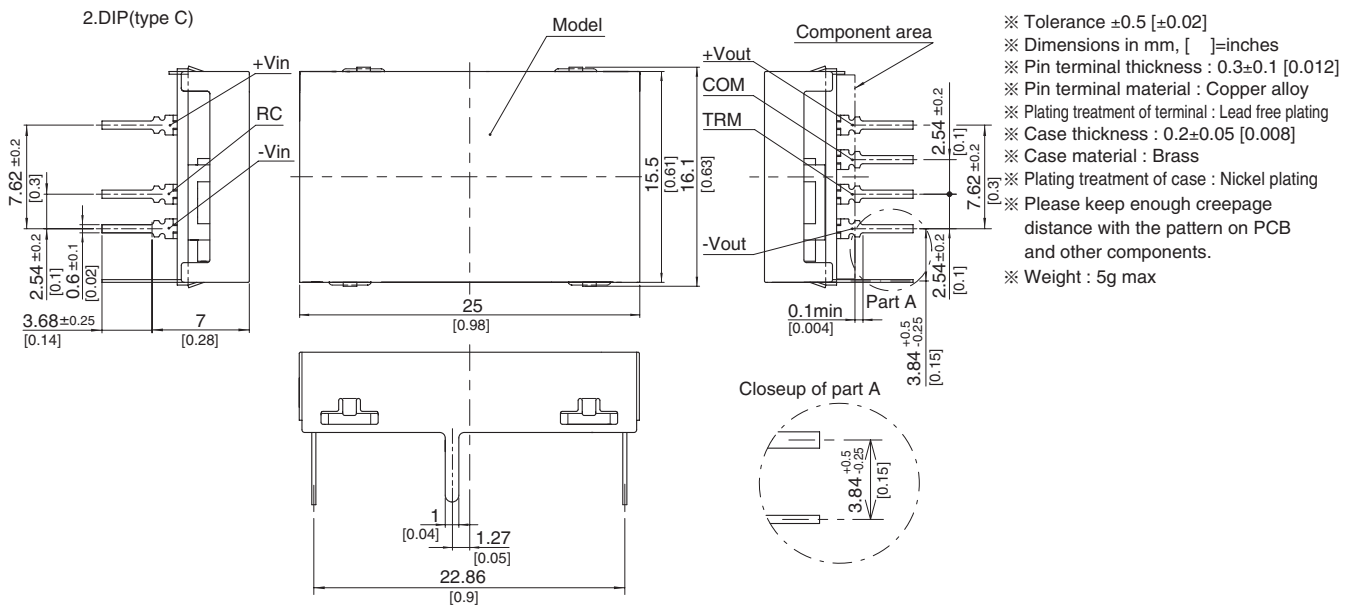
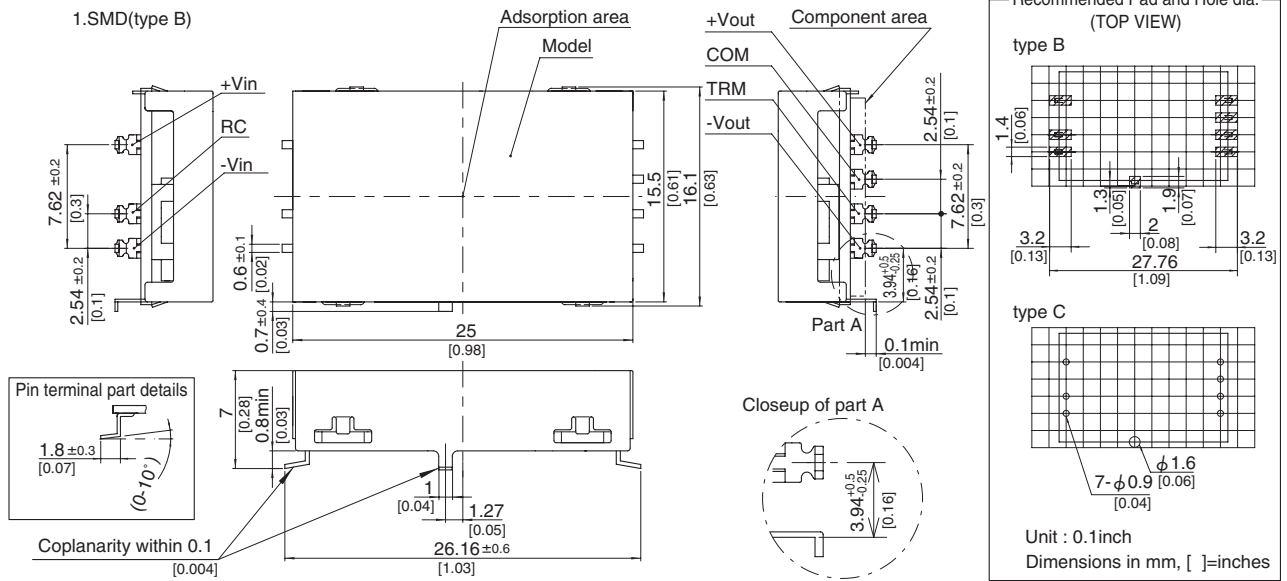

SUCS6

SUC S 6 12 05 B P - □

① ② ③ ④ ⑤ ⑥ ⑦ ⑧

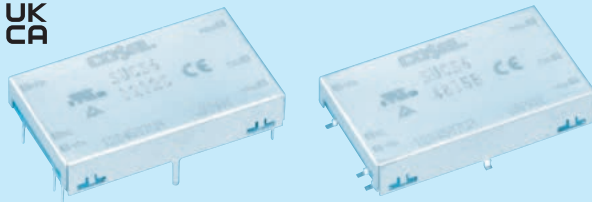

- ① Series name
- ② Single output
- ③ Output wattage
- ④ Input voltage
- ⑤ Output voltage
- ⑥ Mounting type
B :SMD
C :DIP
- ⑦ Packing form
Blank:Plastic cover
P :Tray (SMD type)
- ⑧ Optional
G :Capacitor between Input and Output is removed.
C :with coating (only DIP type)*
* Safety standards are pending

MODEL	SUCS6053R3	SUCS60505	SUCS60512	SUCS60515	SUCS6123R3	SUCS61205	SUCS61212	SUCS61215	
MAX OUTPUT WATTAGE[W]	3.96	5	6	6	4.46	6	6	6	
DC OUTPUT	VOLTAGE[V] *1	3.3	5	12	15	3.3	5	12	15
	CURRENT[A]	1.2	1	0.5	0.4	1.35	1.2	0.5	0.4

SPECIFICATIONS

	MODEL	SUCS6053R3	SUCS60505	SUCS60512	SUCS60515	SUCS6123R3	SUCS61205	SUCS61212	SUCS61215	
INPUT	VOLTAGE[V]	DC4.5 - 9				DC9 - 18				
	CURRENT[A] *2	1.100typ	1.316typ	1.500typ	1.500typ	0.502typ	0.617typ	0.588typ	0.588typ	
	EFFICIENCY[%] *2	72typ	76typ	80typ	80typ	74typ	81typ	85typ	85typ	
OUTPUT	VOLTAGE[V]	3.3	5	12	15	3.3	5	12	15	
	CURRENT[A]	1.2	1	0.5	0.4	1.35	1.2	0.5	0.4	
	LINE REGULATION[mV]	20max	20max	48max	60max	20max	20max	48max	60max	
	LOAD REGULATION[mV]	40max	40max	100max	120max	40max	40max	100max	120max	
	RIPPLE[mVp-p]	-20 to +55°C *3	80max	80max	120max	120max	80max	80max	120max	120max
		-40 to -20°C *3	120max	120max	150max	150max	120max	120max	150max	150max
	RIPPLE NOISE[mVp-p]	-20 to +55°C *3	120max	120max	150max	150max	120max	120max	150max	150max
		-40 to -20°C *3	200max	200max	200max	200max	200max	200max	200max	200max
	TEMPERATURE REGULATION[mV]	-20 to +55°C	50max	50max	150max	180max	50max	50max	150max	180max
		-40 to +55°C	80max	80max	240max	290max	80max	80max	240max	290max
	DRIFT[mV] *4	20max	20max	48max	60max	20max	20max	48max	60max	
	START-UP TIME[ms]	20max (Minimum input, Io=100%)								
OUTPUT VOLTAGE ADJUSTMENT RANGE	Fixed (TRM pin open) ±5% adjustable by external VR									
OUTPUT VOLTAGE SETTING[V] (±3%)	3.21 - 3.42	4.90 - 5.21	11.64 - 12.36	14.55 - 15.45	3.21 - 3.42	4.90 - 5.21	11.64 - 12.36	14.55 - 15.45		
PROTECTION CIRCUIT AND OTHERS	OVERCURRENT PROTECTION	Works over 105% of rating and recovers automatically								
	REMOTE ON/OFF	Provided (Negative logic L : ON, H : OFF)								

MODEL	SUCS6243R3	SUCS62405	SUCS62412	SUCS62415	SUCS6483R3	SUCS64805	SUCS64812	SUCS64815	
MAX OUTPUT WATTAGE[W]	4.46	6	6	6	4.46	6	6	6	
DC OUTPUT	VOLTAGE[V] *1	3.3	5	12	15	3.3	5	12	15
	CURRENT[A]	1.35	1.2	0.5	0.4	1.35	1.2	0.5	0.4

SPECIFICATIONS

	MODEL	SUCS6243R3	SUCS62405	SUCS62412	SUCS62415	SUCS6483R3	SUCS64805	SUCS64812	SUCS64815	
INPUT	VOLTAGE[V]	DC18 - 36				DC36 - 76				
	CURRENT[A] *2	0.248typ	0.309typ	0.291typ	0.291typ	0.121typ	0.154typ	0.145typ	0.145typ	
	EFFICIENCY[%] *2	75typ	81typ	86typ	86typ	77typ	81typ	86typ	86typ	
OUTPUT	VOLTAGE[V]	3.3	5	12	15	3.3	5	12	15	
	CURRENT[A]	1.35	1.2	0.5	0.4	1.35	1.2	0.5	0.4	
	LINE REGULATION[mV]	20max	20max	48max	60max	20max	20max	48max	60max	
	LOAD REGULATION[mV]	40max	40max	100max	120max	40max	40max	100max	120max	
	RIPPLE[mVp-p]	-20 to +55°C *3	80max	80max	120max	120max	80max	80max	120max	120max
		-40 to -20°C *3	120max	120max	150max	150max	120max	120max	150max	150max
	RIPPLE NOISE[mVp-p]	-20 to +55°C *3	120max	120max	150max	150max	120max	120max	150max	150max
		-40 to -20°C *3	200max	200max	200max	200max	200max	200max	200max	200max
	TEMPERATURE REGULATION[mV]	-20 to +55°C	50max	50max	150max	180max	50max	50max	150max	180max
		-40 to +55°C	80max	80max	240max	290max	80max	80max	240max	290max
	DRIFT[mV] *4	20max	20max	48max	60max	20max	20max	48max	60max	
	START-UP TIME[ms]	20max (Minimum input, Io=100%)								
OUTPUT VOLTAGE ADJUSTMENT RANGE	Fixed (TRM pin open) ±5% adjustable by external VR									
OUTPUT VOLTAGE SETTING[V] (±3%)	3.21 - 3.42	4.90 - 5.21	11.64 - 12.36	14.55 - 15.45	3.21 - 3.42	4.90 - 5.21	11.64 - 12.36	14.55 - 15.45		
PROTECTION CIRCUIT AND OTHERS	OVERCURRENT PROTECTION	Works over 105% of rating and recovers automatically								
	REMOTE ON/OFF	Provided (Negative logic L : ON, H : OFF)								

GENERAL SPECIFICATIONS

ISOLATION	INPUT-OUTPUT	AC500V 1minute, Cutoff current = 10mA, DC500V 50MΩ min (20±15°C)
	INPUT-CASE	AC500V 1minute, Cutoff current = 10mA, DC500V 50MΩ min (20±15°C)
	OUTPUT-CASE	AC500V 1minute, Cutoff current = 10mA, DC500V 50MΩ min (20±15°C)
ENVIRONMENT	OPERATING TEMP.HUMID.AND ALTITUDE	-40 to +85°C, 20 - 95%RH (Non condensing) (Refer to "Derating"), 3,000m (10,000feet) max
	STORAGE TEMP.HUMID.AND ALTITUDE	-40 to +100°C, 20 - 95%RH (Non condensing), 9,000m (30,000feet) max
	VIBRATION	10 - 55Hz, 98.0m/s ² (10G), 3minutes period, 60minutes each along X, Y and Z axis
	IMPACT	490.3m/s ² (50G), 11ms, once each along X, Y and Z axis
SAFETY	AGENCY APPROVALS	UL60950-1, C-UL, EN62368-1
OTHERS	CASE SIZE/WEIGHT	32.6 × 7.0 × 19.1mm [1.28 × 0.28 × 0.75 inches] (W×H×D) / 7g max
	COOLING METHOD	Convection/Forced air

- *1 SUCW6xx12/SUCW6xx15 is available as single output, +24V/+30V.
- *2 Rated input 5V, 12V, 24V or 48V DC I_o=100%
- *3 Ripple and Ripple Noise is measured by using measuring board with capacitor with in 25mm from output pin terminals.
- *4 Drift is the change in DC output for an eight hour period after a half-hour warm-up at 25°C.
- * Parallel operation with other model is not possible.

External view

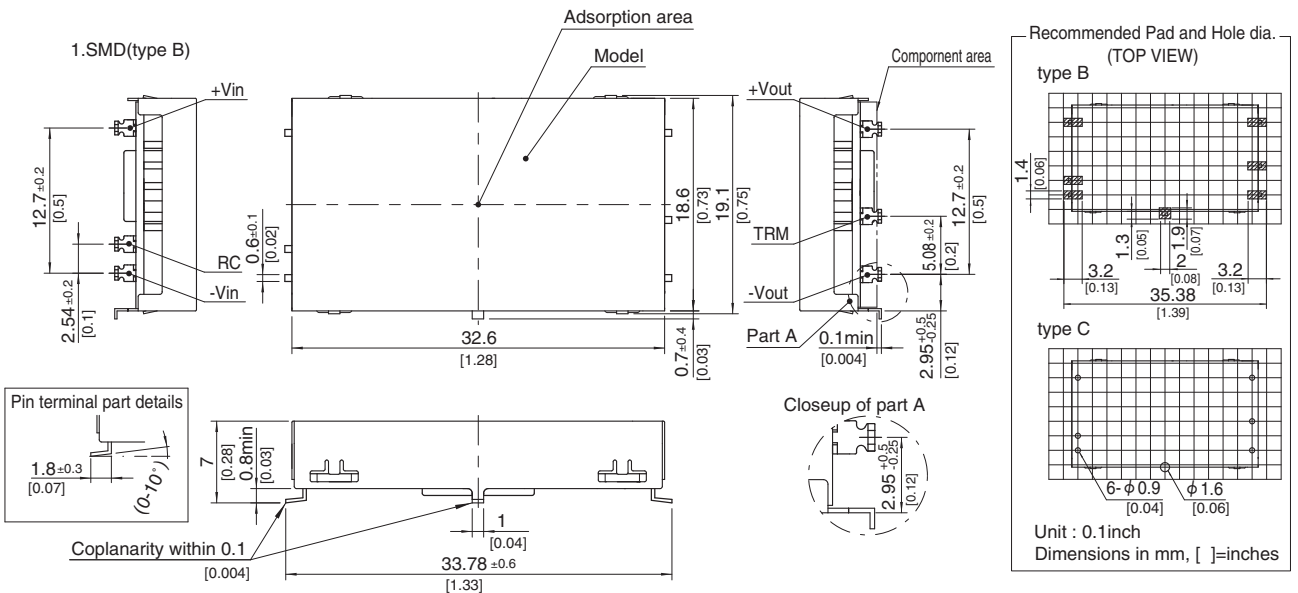

- ※ Tolerance ±0.5 [±0.02]
- ※ Dimensions in mm, []=inches
- ※ Pin terminal thickness : 0.3±0.1 [0.012]
- ※ Pin terminal material : Copper alloy
- ※ Plating treatment of terminal : Lead free plating
- ※ Case thickness : 0.2±0.05 [0.008]
- ※ Case material : Brass
- ※ Plating treatment of case : Nickel plating
- ※ Please keep enough creepage distance with the pattern on PCB and other components.
- ※ Weight : 7g max

SUCW6

SUC W 6 12 12 B P - □

① ② ③ ④ ⑤ ⑥ ⑦ ⑧

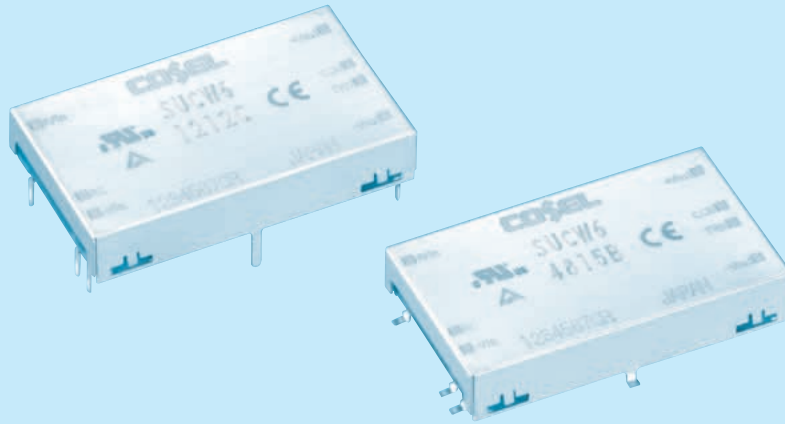

- ① Series name
 - ② Dual output
 - ③ Output wattage
 - ④ Input voltage
 - ⑤ Output voltage
 - ⑥ Mounting type
B : SMD
C : DIP
 - ⑦ Packing form
Blank: Plastic cover
P : Tray (SMD type)
 - ⑧ Optional
G : Capacitor between Input and Output is removed.
C : with coating (only DIP type)*
- * Safety standards are pending

MODEL	SUCW60512	SUCW60515	SUCW61212	SUCW61215	SUCW62412	SUCW62415	SUCW64812	SUCW64815
MAX OUTPUT WATTAGE[W]	6	6	6	6	6	6	6	6
DC OUTPUT	VOLTAGE[V] *1	± 12 or +24	± 15 or +30	± 12 or +24	± 15 or +30	± 12 or +24	± 12 or +24	± 15 or +30
	CURRENT[A]	0.25	0.2	0.25	0.2	0.25	0.25	0.2

SPECIFICATIONS

	MODEL	SUCW60512	SUCW60515	SUCW61212	SUCW61215	SUCW62412	SUCW62415	SUCW64812	SUCW64815	
INPUT	VOLTAGE[V]	DC4.5 - 9		DC9 - 18		DC18 - 36		DC36 - 76		
	CURRENT[A] *2	1.538typ	1.538typ	0.588typ	0.588typ	0.291typ	0.291typ	0.145typ	0.145typ	
	EFFICIENCY[%] *2	78typ	78typ	85typ	85typ	86typ	86typ	86typ	86typ	
OUTPUT	VOLTAGE[V]	± 12(+24)	± 15(+30)	± 12(+24)	± 15(+30)	± 12(+24)	± 15(+30)	± 12(+24)	± 15(+30)	
	CURRENT[A]	0.25	0.2	0.25	0.2	0.25	0.2	0.25	0.2	
	LINE REGULATION[mV]	60max	75max	60max	75max	60max	75max	60max	75max	
	LOAD REGULATION[mV]	600max	750max	600max	750max	600max	750max	600max	750max	
	RIPPLE[mVp-p]	-20 to +55°C *3	120max	120max	120max	120max	120max	120max	120max	120max
		-40 to -20°C *3	150max	150max	150max	150max	150max	150max	150max	150max
	RIPPLE NOISE[mVp-p]	-20 to +55°C *3	150max	150max	150max	150max	150max	150max	150max	150max
		-40 to -20°C *3	200max	200max	200max	200max	200max	200max	200max	200max
	TEMPERATURE REGULATION[mV]	-20 to +55°C	150max	180max	150max	180max	150max	180max	150max	180max
		-40 to +55°C	240max	290max	240max	290max	240max	290max	240max	290max
DRIFT[mV] *4	50max	60max	50max	60max	50max	60max	50max	60max		
START-UP TIME[ms]	20max (Minimum input, Io=100%)									
OUTPUT VOLTAGE ADJUSTMENT RANGE	Fixed (TRM pin open) ±5% adjustable by external VR									
OUTPUT VOLTAGE SETTING[V] (±5%)	11.40 - 12.60	14.25 - 15.75	11.40 - 12.60	14.25 - 15.75	11.40 - 12.60	14.25 - 15.75	11.40 - 12.60	14.25 - 15.75		
PROTECTION CIRCUIT AND OTHERS	OVERCURRENT PROTECTION	Works over 105% of rating and recovers automatically								
	REMOTE ON/OFF	Provided (Negative logic L : ON, H : OFF)								
ISOLATION	INPUT-OUTPUT	AC500V 1minute, Cutoff current = 10mA, DC500V 50MΩ min (20±15°C)								
	INPUT-CASE	AC500V 1minute, Cutoff current = 10mA, DC500V 50MΩ min (20±15°C)								
	OUTPUT-CASE	AC500V 1minute, Cutoff current = 10mA, DC500V 50MΩ min (20±15°C)								
ENVIRONMENT	OPERATING TEMP., HUMID. AND ALTITUDE	-40 to +85°C, 20 - 95%RH (Non condensing) (Refer to "Derating"), 3,000m (10,000feet) max								
	STORAGE TEMP., HUMID. AND ALTITUDE	-40 to +100°C, 20 - 95%RH (Non condensing), 9,000m (30,000feet) max								
	VIBRATION	10 - 55Hz, 98.0m/s ² (10G), 3minutes period, 60minutes each along X, Y and Z axis								
	IMPACT	490.3m/s ² (50G), 11ms, once each along X, Y and Z axis								
SAFETY	AGENCY APPROVALS	UL60950-1, C-UL, EN62368-1								
OTHERS	CASE SIZE/WEIGHT	32.6 × 7.0 × 19.1mm [1.28 × 0.28 × 0.75 inches] (W × H × D) / 7g max								
	COOLING METHOD	Convection/Forced air								

*1 Output pins can be connected in series to make a 24V/30V output.
 *2 Rated input 5V, 12V, 24V or 48V DC Io=100%
 *3 Ripple and Ripple Noise is measured by using measuring board with capacitor with in 25mm from output pin terminals.
 *4 Drift is the change in DC output for an eight hour period after a half-hour warm-up at 25°C.
 * Parallel operation with other model is not possible.

External view

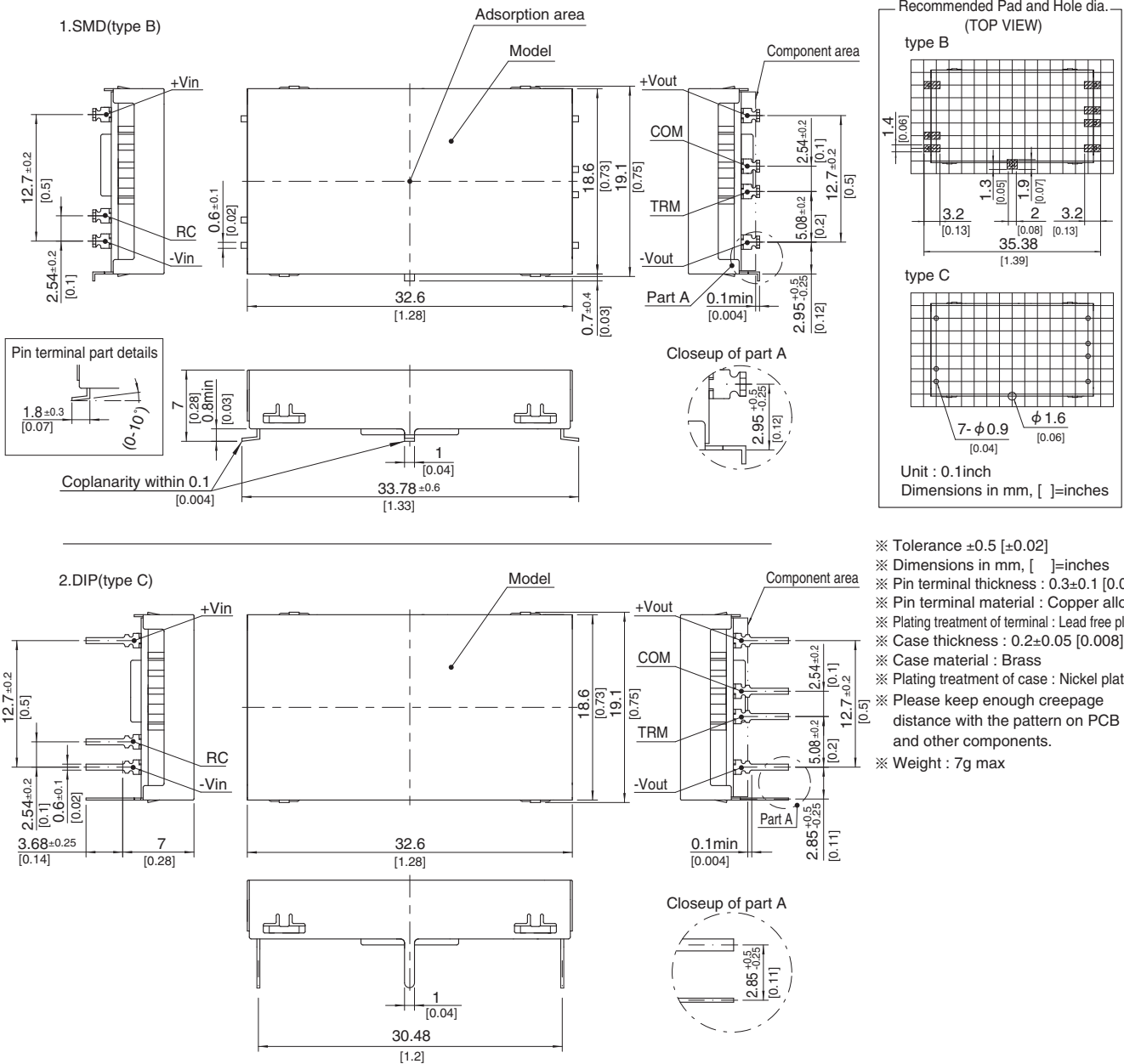

- ※ Tolerance ±0.5 [±0.02]
- ※ Dimensions in mm, []=inches
- ※ Pin terminal thickness : 0.3±0.1 [0.012]
- ※ Pin terminal material : Copper alloy
- ※ Plating treatment of terminal : Lead free plating
- ※ Case thickness : 0.2±0.05 [0.008]
- ※ Case material : Brass
- ※ Plating treatment of case : Nickel plating
- ※ Please keep enough creepage distance with the pattern on PCB and other components.
- ※ Weight : 7g max

SUCS10

SUC S 10 12 05 B P - □

① ② ③ ④ ⑤ ⑥ ⑦ ⑧

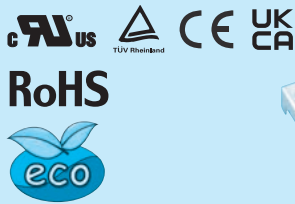

- ① Series name
- ② Single output
- ③ Output wattage
- ④ Input voltage
- ⑤ Output voltage
- ⑥ Mounting type
B :SMD
C :DIP
- ⑦ Packing form
Blank:Plastic cover
P :Tray (SMD type)
- ⑧ Optional
G :Capacitor between Input and Output is removed.
C :with coating (only DIP type)*
* Safety standards are pending

MODEL	SUCS10053R3	SUCS100505	SUCS100512	SUCS100515	SUCS10123R3	SUCS101205	SUCS101212	SUCS101215
MAX OUTPUT WATTAGE[W]	8.58	10	10.8	10.5	8.58	10	12	12
DC OUTPUT	VOLTAGE[V] *1	3.3	5	12	15	3.3	5	12
	CURRENT[A]	2.6	2	0.9	0.7	2.6	2	0.8

SPECIFICATIONS

	MODEL	SUCS10053R3	SUCS100505	SUCS100512	SUCS100515	SUCS10123R3	SUCS101205	SUCS101212	SUCS101215	
INPUT	VOLTAGE[V]	DC4.5 - 9				DC9 - 18				
	CURRENT[A] *2	2.12typ	2.41typ	2.54typ	2.47typ	0.872typ	0.980typ	1.15typ	1.15typ	
	EFFICIENCY[%] *2	81typ	83typ	85typ	85typ	82typ	85typ	87typ	87typ	
OUTPUT	VOLTAGE[V]	3.3	5	12	15	3.3	5	12	15	
	CURRENT[A]	2.6	2	0.9	0.7	2.6	2	1	0.8	
	LINE REGULATION[mV]	20max	20max	48max	60max	20max	20max	48max	60max	
	LOAD REGULATION[mV]	40max	40max	100max	120max	40max	40max	100max	120max	
	RIPPLE[mVp-p]	-20 to +55°C *3	80max	80max	120max	120max	80max	80max	120max	120max
		-40 to -20°C *3	120max	120max	150max	150max	120max	120max	150max	150max
	RIPPLE NOISE[mVp-p]	-20 to +55°C *3	120max	120max	150max	150max	120max	120max	150max	150max
		-40 to -20°C *3	200max	200max	200max	200max	200max	200max	200max	200max
	TEMPERATURE REGULATION[mV]	-20 to +55°C	50max	50max	150max	180max	50max	50max	150max	180max
		-40 to +55°C	80max	80max	240max	290max	80max	80max	240max	290max
	DRIFT[mV] *4	20max	20max	48max	60max	20max	20max	48max	60max	
START-UP TIME[ms]	20max (Minimum input, Io=100%)									
OUTPUT VOLTAGE ADJUSTMENT RANGE	Fixed (TRM pin open) ±5% adjustable by external VR									
OUTPUT VOLTAGE SETTING[V] (±3%)	3.21 - 3.42	4.90 - 5.21	11.64 - 12.36	14.55 - 15.45	3.21 - 3.42	4.90 - 5.21	11.64 - 12.36	14.55 - 15.45		
PROTECTION CIRCUIT AND OTHERS	OVERCURRENT PROTECTION	Works over 105% of rating and recovers automatically								
	REMOTE ON/OFF	Provided (Negative logic L : ON, H : OFF)								

MODEL	SUCS10243R3	SUCS102405	SUCS102412	SUCS102415	SUCS10483R3	SUCS104805	SUCS104812	SUCS104815
MAX OUTPUT WATTAGE[W]	8.58	10	12	12	8.58	10	12	12
DC OUTPUT	VOLTAGE[V] *1	3.3	5	12	15	3.3	5	12
	CURRENT[A]	2.6	2	1	0.8	2.6	2	0.8

SPECIFICATIONS

	MODEL	SUCS10243R3	SUCS102405	SUCS102412	SUCS102415	SUCS10483R3	SUCS104805	SUCS104812	SUCS104815	
INPUT	VOLTAGE[V]	DC18 - 36				DC36 - 76				
	CURRENT[A] *2	0.436typ	0.490typ	0.575typ	0.575typ	0.218typ	0.245typ	0.287typ	0.287typ	
	EFFICIENCY[%] *2	82typ	85typ	87typ	87typ	82typ	85typ	87typ	87typ	
OUTPUT	VOLTAGE[V]	3.3	5	12	15	3.3	5	12	15	
	CURRENT[A]	2.6	2	1	0.8	2.6	2	1	0.8	
	LINE REGULATION[mV]	20max	20max	48max	60max	20max	20max	48max	60max	
	LOAD REGULATION[mV]	40max	40max	100max	120max	40max	40max	100max	120max	
	RIPPLE[mVp-p]	-20 to +55°C *3	80max	80max	120max	120max	80max	80max	120max	120max
		-40 to -20°C *3	120max	120max	150max	150max	120max	120max	150max	150max
	RIPPLE NOISE[mVp-p]	-20 to +55°C *3	120max	120max	150max	150max	120max	120max	150max	150max
		-40 to -20°C *3	200max	200max	200max	200max	200max	200max	200max	200max
	TEMPERATURE REGULATION[mV]	-20 to +55°C	50max	50max	150max	180max	50max	50max	150max	180max
		-40 to +55°C	80max	80max	240max	290max	80max	80max	240max	290max
	DRIFT[mV] *4	20max	20max	48max	60max	20max	20max	48max	60max	
START-UP TIME[ms]	20max (Minimum input, Io=100%)									
OUTPUT VOLTAGE ADJUSTMENT RANGE	Fixed (TRM pin open) ±5% adjustable by external VR									
OUTPUT VOLTAGE SETTING[V] (±3%)	3.21 - 3.42	4.90 - 5.21	11.64 - 12.36	14.55 - 15.45	3.21 - 3.42	4.90 - 5.21	11.64 - 12.36	14.55 - 15.45		
PROTECTION CIRCUIT AND OTHERS	OVERCURRENT PROTECTION	Works over 105% of rating and recovers automatically								
	REMOTE ON/OFF	Provided (Negative logic L : ON, H : OFF)								

GENERAL SPECIFICATIONS

ISOLATION	INPUT-OUTPUT	AC500V 1minute, Cutoff current = 10mA, DC500V 50M Ω min (20 \pm 15 $^{\circ}$ C)
	INPUT-CASE	AC500V 1minute, Cutoff current = 10mA, DC500V 50M Ω min (20 \pm 15 $^{\circ}$ C)
	OUTPUT-CASE	AC500V 1minute, Cutoff current = 10mA, DC500V 50M Ω min (20 \pm 15 $^{\circ}$ C)
ENVIRONMENT	OPERATING TEMP., HUMID. AND ALTITUDE	-40 to +85 $^{\circ}$ C, 20 - 95%RH (Non condensing) (Refer to "Derating"), 3,000m (10,000feet) max
	STORAGE TEMP., HUMID. AND ALTITUDE	-40 to +100 $^{\circ}$ C, 20 - 95%RH (Non condensing), 9,000m (30,000feet) max
	VIBRATION	10 - 55Hz, 98.0m/s 2 (10G), 3minutes period, 60minutes each along X, Y and Z axis
	IMPACT	490.3m/s 2 (50G), 11ms, once each along X, Y and Z axis
SAFETY	AGENCY APPROVALS	UL60950-1, C-UL, EN62368-1
OTHERS	CASE SIZE/WEIGHT	40.2 x 7.0 x 22.0mm [1.58 x 0.28 x 0.87 inches] (W x H x D) / 10g max
	COOLING METHOD	Convection/Forced air

- *1 SUCW10xx12/SUCW10xx15 is available as single output, +24V/+30V.
- *2 Rated input 5V, 12V, 24V or 48V DC Io=100%
- *3 Ripple and Ripple Noise is measured by using measuring board with capacitor with in 25mm from output pin terminals.
- *4 Drift is the change in DC output for an eight hour period after a half-hour warm-up at 25 $^{\circ}$ C.
- * Parallel operation with other model is not possible.

External view

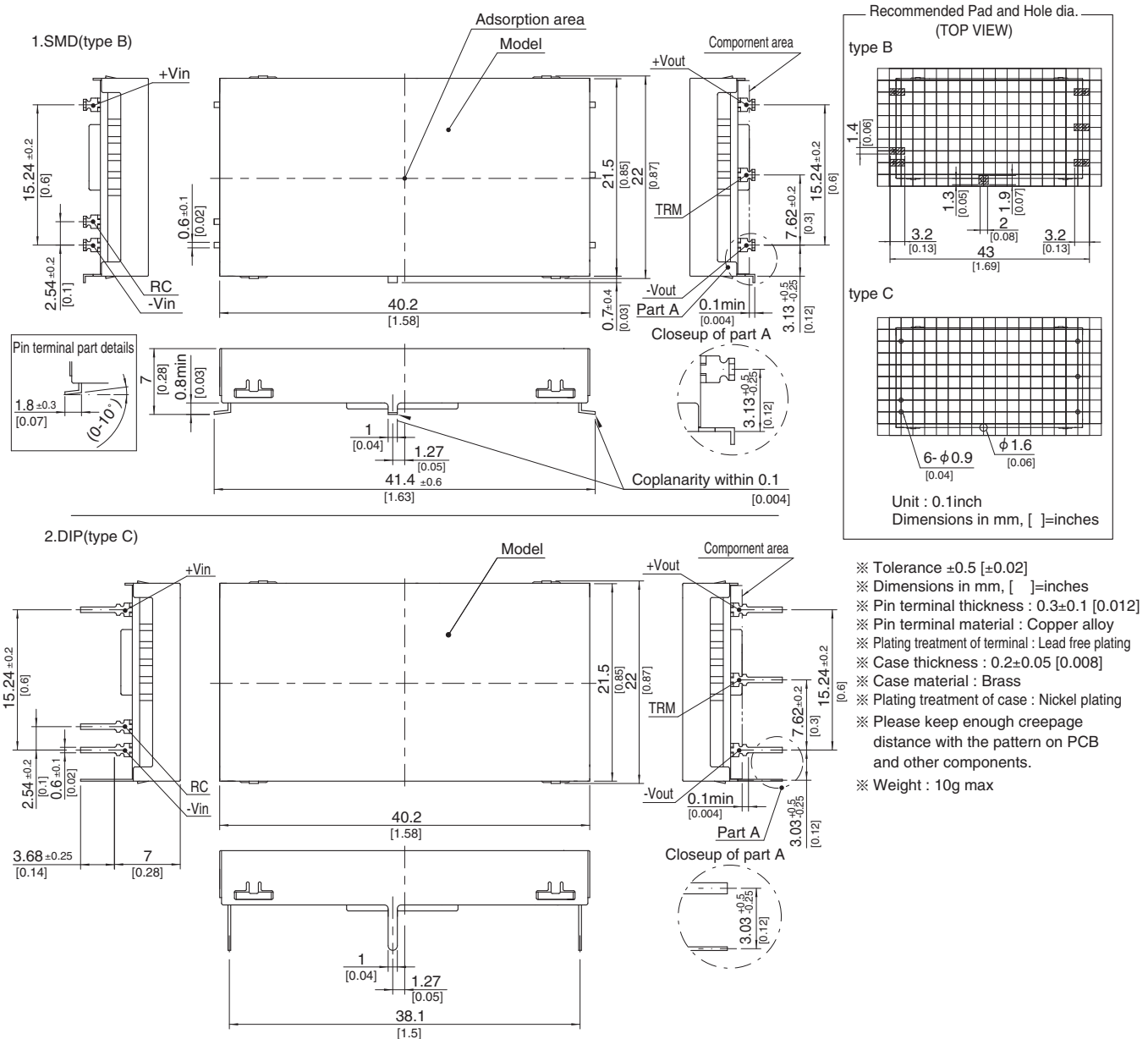

SUCW10

SUC W 10 12 12 B P - □
 ① ② ③ ④ ⑤ ⑥ ⑦ ⑧



- ① Series name
 - ② Dual output
 - ③ Output wattage
 - ④ Input voltage
 - ⑤ Output voltage
 - ⑥ Mounting type
B : SMD
C : DIP
 - ⑦ Packing form
Blank: Plastic cover
P : Tray(SMD type)
 - ⑧ Optional
G : Capacitor between Input and Output is removed.
C : with coating (only DIP type)*
- * Safety standards are pending

MODEL	SUCW100512	SUCW100515	SUCW101212	SUCW101215	SUCW102412	SUCW102415	SUCW104812	SUCW104815
MAX OUTPUT WATTAGE[W]	10.8	10.5	10.8	10.5	10.8	10.5	10.8	10.5
DC OUTPUT	VOLTAGE[V] *1	± 12 or +24	± 15 or +30	± 12 or +24	± 15 or +30	± 12 or +24	± 12 or +24	± 15 or +30
	CURRENT[A]	0.45	0.35	0.45	0.35	0.45	0.45	0.35

SPECIFICATIONS

MODEL	SUCW100512	SUCW100515	SUCW101212	SUCW101215	SUCW102412	SUCW102415	SUCW104812	SUCW104815	
INPUT	VOLTAGE[V]	DC4.5 - 9		DC9 - 18		DC18 - 36		DC36 - 76	
	CURRENT[A] *2	2.51typ	2.44typ	1.05typ	1.02typ	0.523typ	0.509typ	0.262typ 0.254typ	
	EFFICIENCY[%] *2	86typ	86typ	86typ	86typ	86typ	86typ	86typ	
OUTPUT	VOLTAGE[V]	± 12(+24)	± 15(+30)	± 12(+24)	± 15(+30)	± 12(+24)	± 15(+30)	± 12(+24) ± 15(+30)	
	CURRENT[A]	0.45	0.35	0.45	0.35	0.45	0.35	0.45 0.35	
	LINE REGULATION[mV]	60max	75max	60max	75max	60max	75max	60max 75max	
	LOAD REGULATION[mV]	600max	750max	600max	750max	600max	750max	600max 750max	
	RIPPLE[mVp-p]	-20 to +55°C *3	120max	120max	120max	120max	120max	120max	120max
		-40 to -20°C *3	150max	150max	150max	150max	150max	150max	150max
	RIPPLE NOISE[mVp-p]	-20 to +55°C *3	150max	150max	150max	150max	150max	150max	150max
		-40 to -20°C *3	200max	200max	200max	200max	200max	200max	200max
	TEMPERATURE REGULATION[mV]	-20 to +55°C	150max	180max	150max	180max	150max	180max	150max 180max
		-40 to +55°C	240max	290max	240max	290max	240max	290max	240max 290max
DRIFT[mV] *4	50max	60max	50max	60max	50max	60max	50max 60max		
START-UP TIME[ms]	20max (Minimum input, Io=100%)								
OUTPUT VOLTAGE ADJUSTMENT RANGE	Fixed (TRM pin open) ±5% adjustable by external VR								
OUTPUT VOLTAGE SETTING[V] (±5%)	11.40 - 12.60	14.25 - 15.75	11.40 - 12.60	14.25 - 15.75	11.40 - 12.60	14.25 - 15.75	11.40 - 12.60	14.25 - 15.75	
PROTECTION CIRCUIT AND OTHERS	OVERCURRENT PROTECTION	Works over 105% of rating and recovers automatically							
	REMOTE ON/OFF	Provided (Negative logic L : ON, H : OFF)							
ISOLATION	INPUT-OUTPUT	AC500V 1minute, Cutoff current = 10mA, DC500V 50MΩ min (20±15°C)							
	INPUT-CASE	AC500V 1minute, Cutoff current = 10mA, DC500V 50MΩ min (20±15°C)							
	OUTPUT-CASE	AC500V 1minute, Cutoff current = 10mA, DC500V 50MΩ min (20±15°C)							
ENVIRONMENT	OPERATING TEMP., HUMID. AND ALTITUDE	-40 to +85°C, 20 - 95%RH (Non condensing) (Refer to "Derating"), 3,000m (10,000feet) max							
	STORAGE TEMP., HUMID. AND ALTITUDE	-40 to +100°C, 20 - 95%RH (Non condensing), 9,000m (30,000feet) max							
	VIBRATION	10 - 55Hz, 98.0m/s ² (10G), 3minutes period, 60minutes each along X, Y and Z axis							
	IMPACT	490.3m/s ² (50G), 11ms, once each along X, Y and Z axis							
SAFETY	AGENCY APPROVALS	UL60950-1, C-UL, EN62368-1							
OTHERS	CASE SIZE/WEIGHT	40.2 × 7.0 × 22.0mm [1.58 × 0.28 × 0.87 inches] (W × H × D) / 10g max							
	COOLING METHOD	Convection/Forced air							

*1 Output pins can be connected in series to make a 24V/30V output.
 *2 Rated input 5V, 12V, 24V or 48V DC Io=100%
 *3 Ripple and Ripple Noise is measured by using measuring board with capacitor with in 25mm from output pin terminals.
 *4 Drift is the change in DC output for an eight hour period after a half-hour warm-up at 25°C.
 * Parallel operation with other model is not possible.

External view

1.SMD(type B)

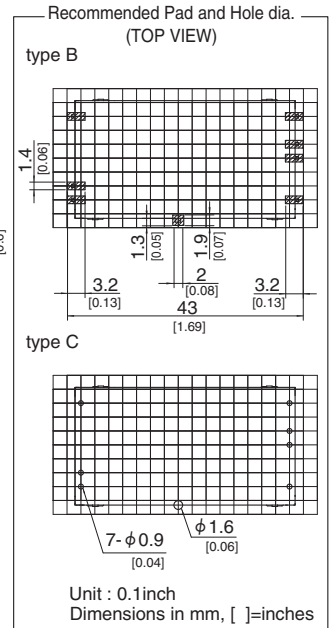
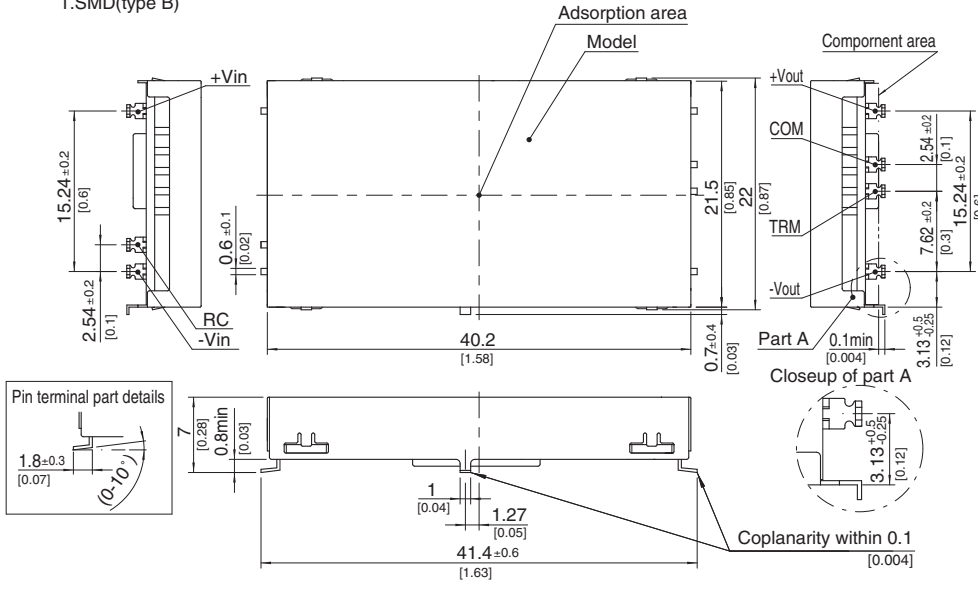

2.DIP(type C)

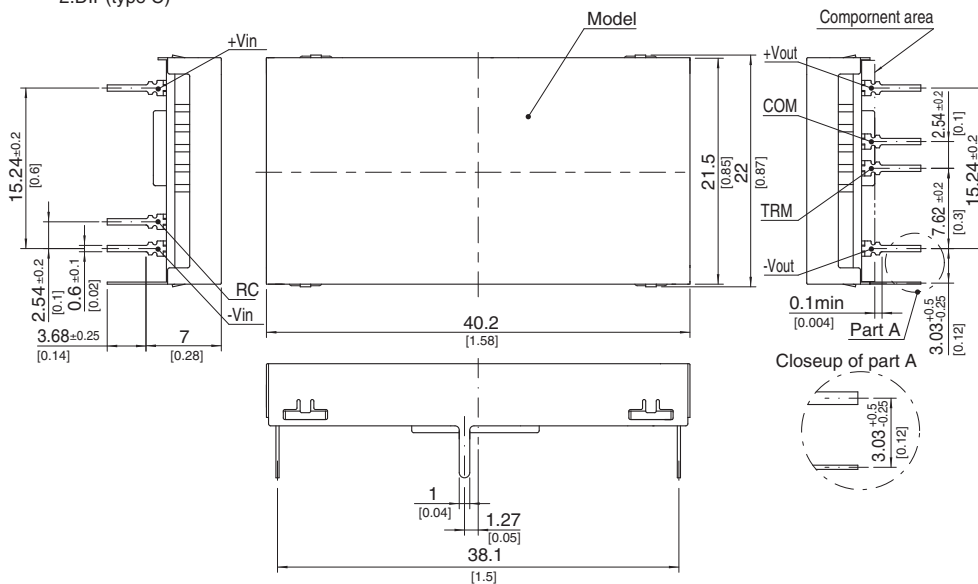

- ※ Tolerance ±0.5 [±0.02]
- ※ Dimensions in mm, []=inches
- ※ Pin terminal thickness : 0.3±0.1 [0.012]
- ※ Pin terminal material : Copper alloy
- ※ Plating treatment of terminal : Lead free plating
- ※ Case thickness : 0.2±0.05 [0.008]
- ※ Case material : Brass
- ※ Plating treatment of case : Nickel plating
- ※ Please keep enough creepage distance with the pattern on PCB and other components.
- ※ Weight : 10g max

SUTS3

SUT S 3 12 05 - □

① ② ③ ④ ⑤ ⑥

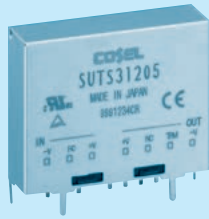
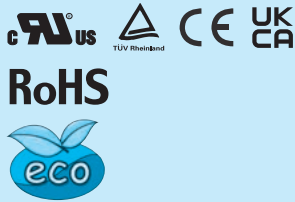

- ① Series name
 - ② Single output
 - ③ Output wattage
 - ④ Input voltage
 - ⑤ Output voltage
 - ⑥ Optional
- G : Capacitor between Input and Output is removed.

MODEL	SUTS3053R3	SUTS30505	SUTS30512	SUTS30515	SUTS3123R3	SUTS31205	SUTS31212	SUTS31215
MAX OUTPUT WATTAGE[W]	1.98	3	3	3	1.98	3	3	3
DC OUTPUT	VOLTAGE[V] *1	3.3	5	12	15	3.3	5	12
	CURRENT[A]	0.6	0.6	0.25	0.2	0.6	0.6	0.25

SPECIFICATIONS

	MODEL	SUTS3053R3	SUTS30505	SUTS30512	SUTS30515	SUTS3123R3	SUTS31205	SUTS31212	SUTS31215	
INPUT	VOLTAGE[V]	DC4.5 - 9				DC9 - 18				
	CURRENT[A] *2	0.550typ	0.800typ	0.780typ	0.780typ	0.223typ	0.325typ	0.317typ	0.321typ	
	EFFICIENCY[%] *2	72typ	75typ	77typ	77typ	74typ	77typ	79typ	78typ	
OUTPUT	VOLTAGE[V]	3.3	5	12	15	3.3	5	12	15	
	CURRENT[A]	0.6	0.6	0.25	0.2	0.6	0.6	0.25	0.2	
	LINE REGULATION[mV]	20max	20max	48max	60max	20max	20max	48max	60max	
	LOAD REGULATION[mV]	40max	40max	100max	120max	40max	40max	100max	120max	
	RIPPLE[mVp-p]	-20 to +55°C *3	80max	80max	120max	120max	80max	80max	120max	120max
		-40 to -20°C *3	120max	120max	150max	150max	120max	120max	150max	150max
	RIPPLE NOISE[mVp-p]	-20 to +55°C *3	120max	120max	150max	150max	120max	120max	150max	150max
		-40 to -20°C *3	200max	200max	200max	200max	200max	200max	200max	200max
	TEMPERATURE REGULATION[mV]	-20 to +55°C	50max	50max	150max	180max	50max	50max	150max	180max
		-40 to +55°C	80max	80max	240max	290max	80max	80max	240max	290max
	DRIFT[mV] *4	20max	20max	48max	60max	20max	20max	48max	60max	
START-UP TIME[ms]	20max (Minimum input, Io=100%)									
OUTPUT VOLTAGE ADJUSTMENT RANGE	Fixed (TRM pin open) ±5% adjustable by external VR									
OUTPUT VOLTAGE SETTING[V] (±3%)	3.21 - 3.42	4.90 - 5.21	11.64 - 12.36	14.55 - 15.45	3.21 - 3.42	4.90 - 5.21	11.64 - 12.36	14.55 - 15.45		
PROTECTION CIRCUIT AND OTHERS	OVERCURRENT PROTECTION	Works over 105% of rating and recovers automatically								
	REMOTE ON/OFF	Provided (Negative logic L : ON, H : OFF)								

MODEL	SUTS3243R3	SUTS32405	SUTS32412	SUTS32415	SUTS3483R3	SUTS34805	SUTS34812	SUTS34815
MAX OUTPUT WATTAGE[W]	1.98	3	3	3	1.98	3	3	3
DC OUTPUT	VOLTAGE[V] *1	3.3	5	12	15	3.3	5	12
	CURRENT[A]	0.6	0.6	0.25	0.2	0.6	0.6	0.25

SPECIFICATIONS

	MODEL	SUTS3243R3	SUTS32405	SUTS32412	SUTS32415	SUTS3483R3	SUTS34805	SUTS34812	SUTS34815	
INPUT	VOLTAGE[V]	DC18 - 36				DC36 - 76				
	CURRENT[A] *2	0.114typ	0.163typ	0.159typ	0.161typ	0.057typ	0.082typ	0.080typ	0.080typ	
	EFFICIENCY[%] *2	73typ	77typ	79typ	78typ	72typ	77typ	79typ	79typ	
OUTPUT	VOLTAGE[V]	3.3	5	12	15	3.3	5	12	15	
	CURRENT[A]	0.6	0.6	0.25	0.2	0.6	0.6	0.25	0.2	
	LINE REGULATION[mV]	20max	20max	48max	60max	20max	20max	48max	60max	
	LOAD REGULATION[mV]	40max	40max	100max	120max	40max	40max	100max	120max	
	RIPPLE[mVp-p]	-20 to +55°C *3	80max	80max	120max	120max	80max	80max	120max	120max
		-40 to -20°C *3	120max	120max	150max	150max	120max	120max	150max	150max
	RIPPLE NOISE[mVp-p]	-20 to +55°C *3	120max	120max	150max	150max	120max	120max	150max	150max
		-40 to -20°C *3	200max	200max	200max	200max	200max	200max	200max	200max
	TEMPERATURE REGULATION[mV]	-20 to +55°C	50max	50max	150max	180max	50max	50max	150max	180max
		-40 to +55°C	80max	80max	240max	290max	80max	80max	240max	290max
	DRIFT[mV] *4	20max	20max	48max	60max	20max	20max	48max	60max	
START-UP TIME[ms]	20max (Minimum input, Io=100%)									
OUTPUT VOLTAGE ADJUSTMENT RANGE	Fixed (TRM pin open) ±5% adjustable by external VR									
OUTPUT VOLTAGE SETTING[V] (±3%)	3.21 - 3.42	4.90 - 5.21	11.64 - 12.36	14.55 - 15.45	3.21 - 3.42	4.90 - 5.21	11.64 - 12.36	14.55 - 15.45		
PROTECTION CIRCUIT AND OTHERS	OVERCURRENT PROTECTION	Works over 105% of rating and recovers automatically								
	REMOTE ON/OFF	Provided (Negative logic L : ON, H : OFF)								

GENERAL SPECIFICATIONS

ISOLATION	INPUT-OUTPUT	AC500V 1minute, Cutoff current = 10mA, DC500V 50M Ω min (20 \pm 15 $^{\circ}$ C)
	INPUT-CASE	AC500V 1minute, Cutoff current = 10mA, DC500V 50M Ω min (20 \pm 15 $^{\circ}$ C)
	OUTPUT-CASE	AC500V 1minute, Cutoff current = 10mA, DC500V 50M Ω min (20 \pm 15 $^{\circ}$ C)
ENVIRONMENT	OPERATING TEMP., HUMID. AND ALTITUDE	-40 to +85 $^{\circ}$ C, 20 - 95%RH (Non condensing) (Refer to "Derating"), 3,000m (10,000feet) max
	STORAGE TEMP., HUMID. AND ALTITUDE	-40 to +100 $^{\circ}$ C, 20 - 95%RH (Non condensing), 9,000m (30,000feet) max
	VIBRATION	10 - 55Hz, 98.0m/s 2 (10G), 3minutes period, 60minutes each along X, Y and Z axis
	IMPACT	490.3m/s 2 (50G), 11ms, once each along X, Y and Z axis
SAFETY	AGENCY APPROVALS	UL60950-1, C-UL, EN62368-1
OTHERS	CASE SIZE/WEIGHT	30.0 x 23.4 x 9.15mm [1.18 x 0.92 x 0.36 inches] (W x H x D) / 8g max
	COOLING METHOD	Convection/Forced air

- *1 SUTW3xx12/SUTW3xx15 is available as single output, +24V/+30V.
- *2 Rated input 5V, 12V, 24V or 48V DC Io=100%
- *3 Ripple and Ripple Noise is measured by using measuring board with capacitor with in 25mm from output pin terminals.
- *4 Drift is the change in DC output for an eight hour period after a half-hour warm-up at 25 $^{\circ}$ C.
- * Parallel operation with other model is not possible.

External view

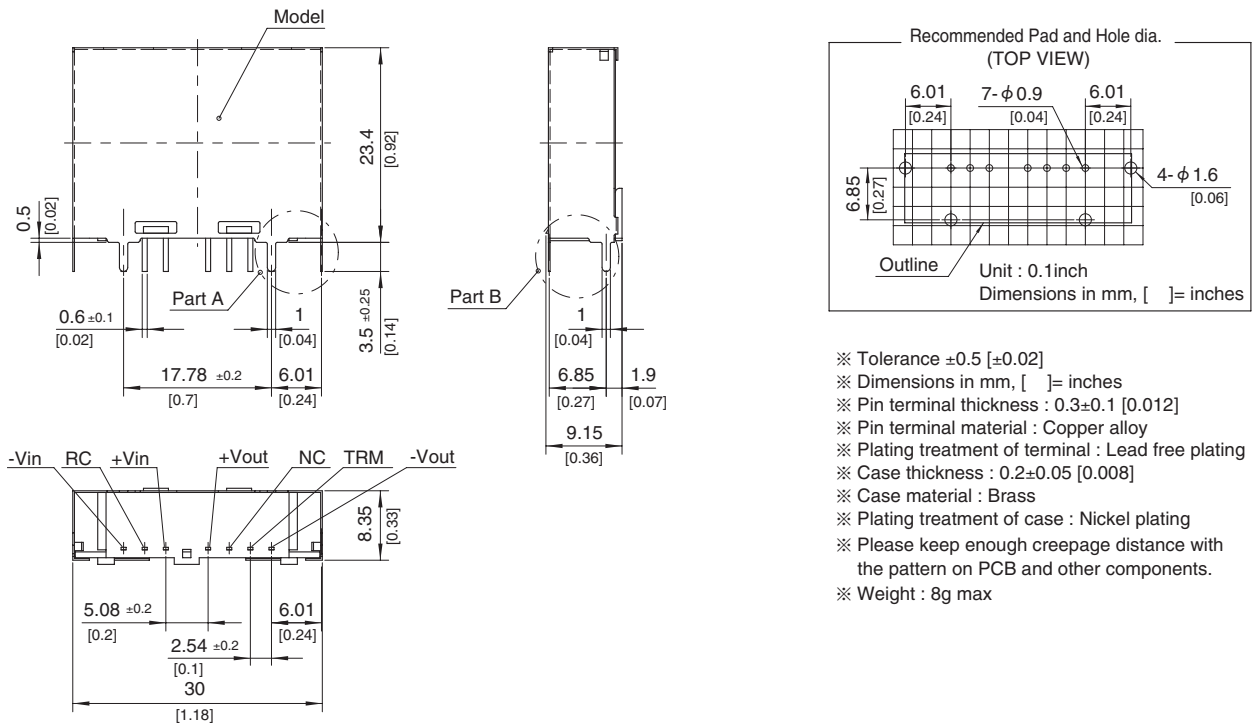

※ Back View

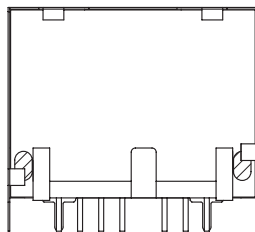

▨ : Conduction Area

Closeup of part A

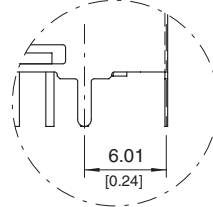

Closeup of part B

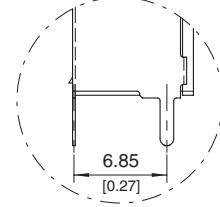

SUTW3

SUT W 3 12 12 - □

① ② ③ ④ ⑤ ⑥

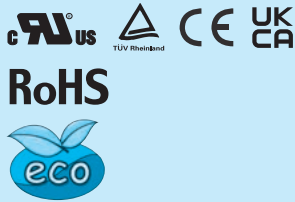

- ① Series name
- ② Dual output
- ③ Output wattage
- ④ Input voltage
- ⑤ Output voltage
- ⑥ Optional
- G :Capacitor between Input and Output is removed.

MODEL	SUTW30512	SUTW30515	SUTW31212	SUTW31215	SUTW32412	SUTW32415	SUTW34812	SUTW34815	
MAX OUTPUT WATTAGE[W]	3.12	3	3.12	3	3.12	3	3.12	3	
DC OUTPUT	VOLTAGE[V] *1	±12 or +24	±15 or +30	±12 or +24	±15 or +30	±12 or +24	±15 or +30	±12 or +24	±15 or +30
	CURRENT[A]	0.13	0.1	0.13	0.1	0.13	0.1	0.13	0.1

SPECIFICATIONS

	MODEL	SUTW30512	SUTW30515	SUTW31212	SUTW31215	SUTW32412	SUTW32415	SUTW34812	SUTW34815	
INPUT	VOLTAGE[V]	DC4.5 - 9		DC9 - 18		DC18 - 36		DC36 - 76		
	CURRENT[A] *2	0.844typ	0.811typ	0.343typ	0.329typ	0.172typ	0.165typ	0.086typ	0.083typ	
	EFFICIENCY[%] *2	74typ	74typ	76typ	76typ	76typ	76typ	76typ	76typ	
OUTPUT	VOLTAGE[V]	±12(+24)	±15(+30)	±12(+24)	±15(+30)	±12(+24)	±15(+30)	±12(+24)	±15(+30)	
	CURRENT[A]	0.13	0.1	0.13	0.1	0.13	0.1	0.13	0.1	
	LINE REGULATION[mV]	60max	75max	60max	75max	60max	75max	60max	75max	
	LOAD REGULATION[mV]	600max	750max	600max	750max	600max	750max	600max	750max	
	RIPPLE[mVp-p]	-20 to +55°C *3	120max	120max	120max	120max	120max	120max	120max	120max
		-40 to -20°C *3	150max	150max	150max	150max	150max	150max	150max	150max
	RIPPLE NOISE[mVp-p]	-20 to +55°C *3	150max	150max	150max	150max	150max	150max	150max	150max
		-40 to -20°C *3	200max	200max	200max	200max	200max	200max	200max	200max
	TEMPERATURE REGULATION[mV]	-20 to +55°C	150max	180max	150max	180max	150max	180max	150max	180max
		-40 to +55°C	240max	290max	240max	290max	240max	290max	240max	290max
DRIFT[mV] *4	50max	60max	50max	60max	50max	60max	50max	60max		
START-UP TIME[ms]	20max (Minimum input, Io=100%)									
OUTPUT VOLTAGE ADJUSTMENT RANGE	Fixed (TRM pin open) ±5% adjustable by external VR									
OUTPUT VOLTAGE SETTING[V] (±5%)	11.40 - 12.60	14.25 - 15.75	11.40 - 12.60	14.25 - 15.75	11.40 - 12.60	14.25 - 15.75	11.40 - 12.60	14.25 - 15.75	11.40 - 12.60	
PROTECTION CIRCUIT AND OTHERS	OVERCURRENT PROTECTION	Works over 105% of rating and recovers automatically								
	REMOTE ON/OFF	Provided (Negative logic L : ON, H : OFF)								
ISOLATION	INPUT-OUTPUT	AC500V 1minute, Cutoff current = 10mA, DC500V 50MΩ min (20±15°C)								
	INPUT-CASE	AC500V 1minute, Cutoff current = 10mA, DC500V 50MΩ min (20±15°C)								
	OUTPUT-CASE	AC500V 1minute, Cutoff current = 10mA, DC500V 50MΩ min (20±15°C)								
ENVIRONMENT	OPERATING TEMP., HUMID. AND ALTITUDE	-40 to +85°C, 20 - 95%RH (Non condensing) (Refer to "Derating"), 3,000m (10,000feet) max								
	STORAGE TEMP., HUMID. AND ALTITUDE	-40 to +100°C, 20 - 95%RH (Non condensing), 9,000m (30,000feet) max								
	VIBRATION	10 - 55Hz, 98.0m/s ² (10G), 3minutes period, 60minutes each along X, Y and Z axis								
	IMPACT	490.3m/s ² (50G), 11ms, once each along X, Y and Z axis								
SAFETY	AGENCY APPROVALS	UL60950-1, C-UL, EN62368-1								
OTHERS	CASE SIZE/WEIGHT	30.0 × 23.4 × 9.15mm [1.18 × 0.92 × 0.36 inches] (W × H × D) / 8g max								
	COOLING METHOD	Convection/Forced air								

*1 Output pins can be connected in series to make a 24V/30V output.
 *2 Rated input 5V, 12V, 24V or 48V DC Io=100%
 *3 Ripple and Ripple Noise is measured by using measuring board with capacitor with in 25mm from output pin terminals.
 *4 Drift is the change in DC output for an eight hour period after a half-hour warm-up at 25°C.
 * Parallel operation with other model is not possible.

External view

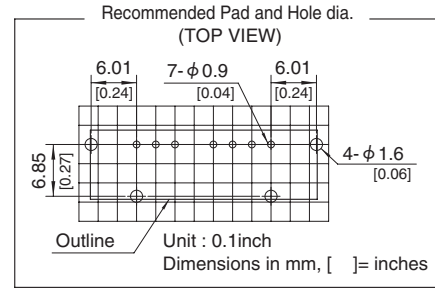
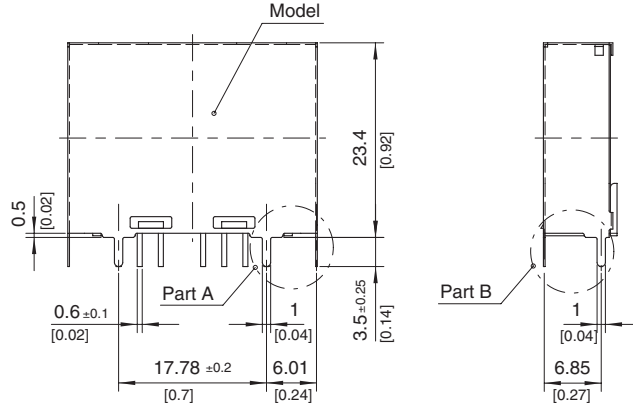

- ※ Tolerance ± 0.5 [± 0.02]
- ※ Dimensions in mm, [] = inches
- ※ Pin terminal thickness : 0.3 ± 0.1 [0.012]
- ※ Pin terminal material : Copper alloy
- ※ Plating treatment of terminal : Lead free plating
- ※ Case thickness : 0.2 ± 0.05 [0.008]
- ※ Case material : Brass
- ※ Plating treatment of case : Nickel plating
- ※ Please keep enough creepage distance with the pattern on PCB and other components.
- ※ Weight : 8g max

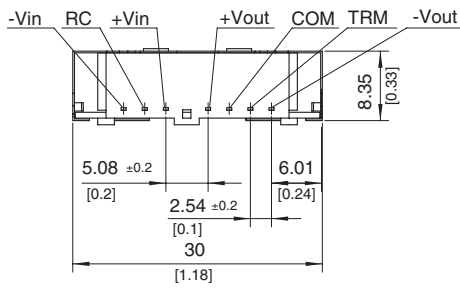

※ Back View

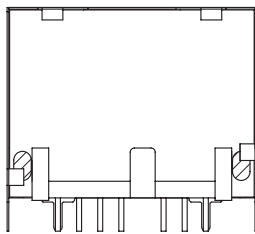

: Conduction Area

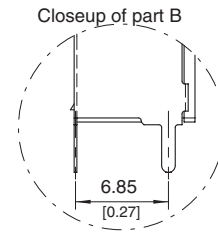
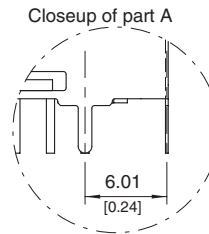

SUTS6

SUT S 6 12 05 - □

① ② ③ ④ ⑤ ⑥

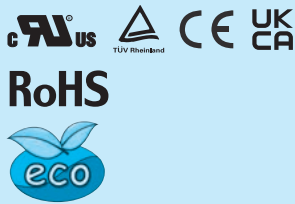

- ① Series name
 - ② Single output
 - ③ Output wattage
 - ④ Input voltage
 - ⑤ Output voltage
 - ⑥ Optional
- G : Capacitor between Input and Output is removed.

MODEL	SUTS6053R3	SUTS60505	SUTS60512	SUTS60515	SUTS6123R3	SUTS61205	SUTS61212	SUTS61215
MAX OUTPUT WATTAGE[W]	3.96	5	6	6	4.46	6	6	6
DC OUTPUT	VOLTAGE[V] *1	3.3	5	12	15	3.3	5	12
	CURRENT[A]	1.2	1	0.5	0.4	1.35	1.2	0.5

SPECIFICATIONS

	MODEL	SUTS6053R3	SUTS60505	SUTS60512	SUTS60515	SUTS6123R3	SUTS61205	SUTS61212	SUTS61215	
INPUT	VOLTAGE[V]	DC4.5 - 9				DC9 - 18				
	CURRENT[A] *2	1.100typ	1.316typ	1.500typ	1.500typ	0.502typ	0.617typ	0.588typ	0.588typ	
	EFFICIENCY[%] *2	72typ	76typ	80typ	80typ	74typ	81typ	85typ	85typ	
OUTPUT	VOLTAGE[V]	3.3	5	12	15	3.3	5	12	15	
	CURRENT[A]	1.2	1	0.5	0.4	1.35	1.2	0.5	0.4	
	LINE REGULATION[mV]	20max	20max	48max	60max	20max	20max	48max	60max	
	LOAD REGULATION[mV]	40max	40max	100max	120max	40max	40max	100max	120max	
	RIPPLE[mVp-p]	-20 to +55°C *3	80max	80max	120max	120max	80max	80max	120max	120max
		-40 to -20°C *3	120max	120max	150max	150max	120max	120max	150max	150max
	RIPPLE NOISE[mVp-p]	-20 to +55°C *3	120max	120max	150max	150max	120max	120max	150max	150max
		-40 to -20°C *3	200max	200max	200max	200max	200max	200max	200max	200max
	TEMPERATURE REGULATION[mV]	-20 to +55°C	50max	50max	150max	180max	50max	50max	150max	180max
		-40 to +55°C	80max	80max	240max	290max	80max	80max	240max	290max
	DRIFT[mV] *4	20max	20max	48max	60max	20max	20max	48max	60max	
	START-UP TIME[ms]	20max (Minimum input, Io=100%)								
OUTPUT VOLTAGE ADJUSTMENT RANGE	Fixed (TRM pin open) ±5% adjustable by external VR									
OUTPUT VOLTAGE SETTING[V] (±3%)	3.21 - 3.42	4.90 - 5.21	11.64 - 12.36	14.55 - 15.45	3.21 - 3.42	4.90 - 5.21	11.64 - 12.36	14.55 - 15.45		
PROTECTION CIRCUIT AND OTHERS	OVERCURRENT PROTECTION	Works over 105% of rating and recovers automatically								
	REMOTE ON/OFF	Provided (Negative logic L : ON, H : OFF)								

MODEL	SUTS6243R3	SUTS62405	SUTS62412	SUTS62415	SUTS6483R3	SUTS64805	SUTS64812	SUTS64815
MAX OUTPUT WATTAGE[W]	4.46	6	6	6	4.46	6	6	6
DC OUTPUT	VOLTAGE[V] *1	3.3	5	12	15	3.3	5	12
	CURRENT[A]	1.35	1.2	0.5	0.4	1.35	1.2	0.5

SPECIFICATIONS

	MODEL	SUTS6243R3	SUTS62405	SUTS62412	SUTS62415	SUTS6483R3	SUTS64805	SUTS64812	SUTS64815	
INPUT	VOLTAGE[V]	DC18 - 36				DC36 - 76				
	CURRENT[A] *2	0.248typ	0.309typ	0.291typ	0.291typ	0.121typ	0.154typ	0.145typ	0.145typ	
	EFFICIENCY[%] *2	75typ	81typ	86typ	86typ	77typ	81typ	86typ	86typ	
OUTPUT	VOLTAGE[V]	3.3	5	12	15	3.3	5	12	15	
	CURRENT[A]	1.35	1.2	0.5	0.4	1.35	1.2	0.5	0.4	
	LINE REGULATION[mV]	20max	20max	48max	60max	20max	20max	48max	60max	
	LOAD REGULATION[mV]	40max	40max	100max	120max	40max	40max	100max	120max	
	RIPPLE[mVp-p]	-20 to +55°C *3	80max	80max	120max	120max	80max	80max	120max	120max
		-40 to -20°C *3	120max	120max	150max	150max	120max	120max	150max	150max
	RIPPLE NOISE[mVp-p]	-20 to +55°C *3	120max	120max	150max	150max	120max	120max	150max	150max
		-40 to -20°C *3	200max	200max	200max	200max	200max	200max	200max	200max
	TEMPERATURE REGULATION[mV]	-20 to +55°C	50max	50max	150max	180max	50max	50max	150max	180max
		-40 to +55°C	80max	80max	240max	290max	80max	80max	240max	290max
	DRIFT[mV] *4	20max	20max	48max	60max	20max	20max	48max	60max	
	START-UP TIME[ms]	20max (Minimum input, Io=100%)								
OUTPUT VOLTAGE ADJUSTMENT RANGE	Fixed (TRM pin open) ±5% adjustable by external VR									
OUTPUT VOLTAGE SETTING[V] (±3%)	3.21 - 3.42	4.90 - 5.21	11.64 - 12.36	14.55 - 15.45	3.21 - 3.42	4.90 - 5.21	11.64 - 12.36	14.55 - 15.45		
PROTECTION CIRCUIT AND OTHERS	OVERCURRENT PROTECTION	Works over 105% of rating and recovers automatically								
	REMOTE ON/OFF	Provided (Negative logic L : ON, H : OFF)								

GENERAL SPECIFICATIONS

ISOLATION	INPUT-OUTPUT	AC500V 1minute, Cutoff current = 10mA, DC500V 50M Ω min (20 \pm 15 $^{\circ}$ C)
	INPUT-CASE	AC500V 1minute, Cutoff current = 10mA, DC500V 50M Ω min (20 \pm 15 $^{\circ}$ C)
	OUTPUT-CASE	AC500V 1minute, Cutoff current = 10mA, DC500V 50M Ω min (20 \pm 15 $^{\circ}$ C)
ENVIRONMENT	OPERATING TEMP., HUMID. AND ALTITUDE	-40 to +85 $^{\circ}$ C, 20 - 95%RH (Non condensing) (Refer to "Derating"), 3,000m (10,000feet) max
	STORAGE TEMP., HUMID. AND ALTITUDE	-40 to +100 $^{\circ}$ C, 20 - 95%RH (Non condensing), 9,000m (30,000feet) max
	VIBRATION	10 - 55Hz, 98.0m/s ² (10G), 3minutes period, 60minutes each along X, Y and Z axis
	IMPACT	490.3m/s ² (50G), 11ms, once each along X, Y and Z axis
SAFETY	AGENCY APPROVALS	UL60950-1, C-UL, EN62368-1
OTHERS	CASE SIZE/WEIGHT	37.6 \times 26.4 \times 9.15mm [1.48 \times 1.04 \times 0.36 inches] (W \times H \times D) / 11g max
	COOLING METHOD	Convection/Forced air

- *1 SUTW6xx12/SUTW6xx15 is available as single output, +24V/+30V.
- *2 Rated input 5V, 12V, 24V or 48V DC I_o=100%
- *3 Ripple and Ripple Noise is measured by using measuring board with capacitor with in 25mm from output pin terminals.
- *4 Drift is the change in DC output for an eight hour period after a half-hour warm-up at 25 $^{\circ}$ C.
- * Parallel operation with other model is not possible.

External view

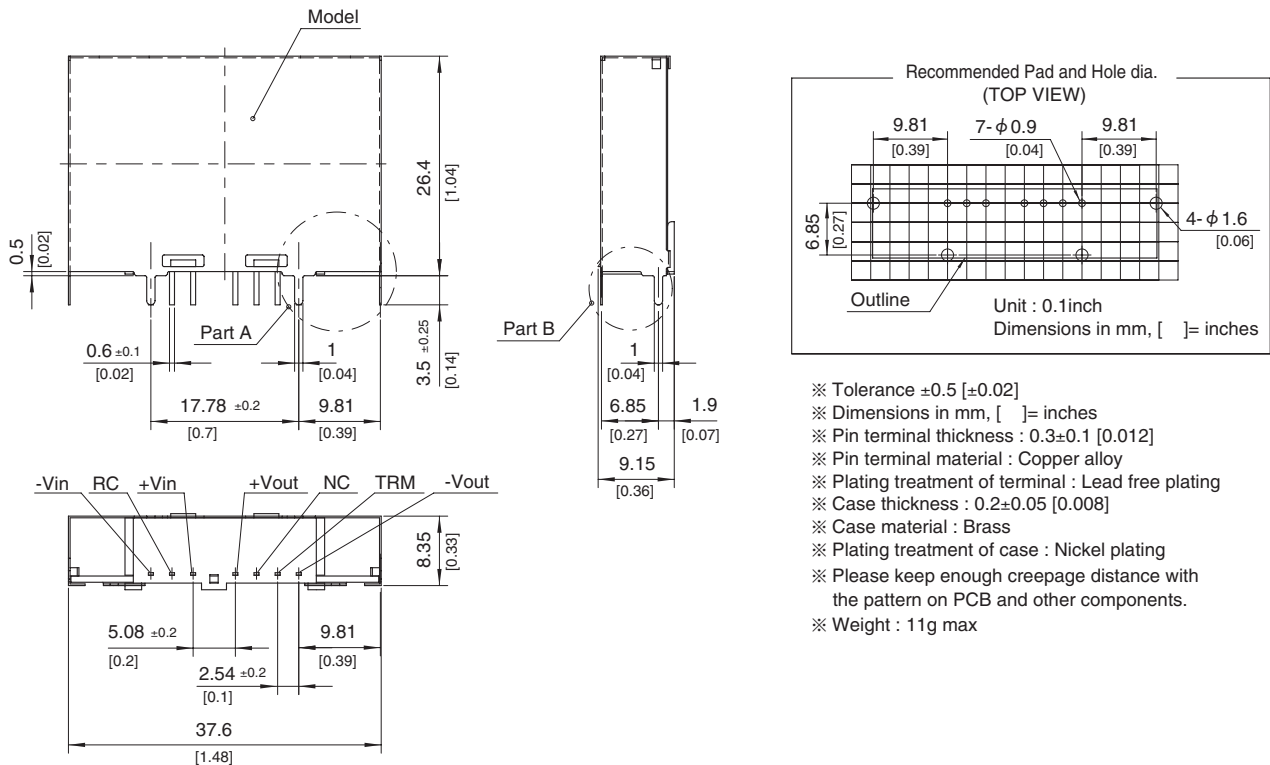

- ※ Tolerance ± 0.5 [± 0.02]
- ※ Dimensions in mm, [] = inches
- ※ Pin terminal thickness : 0.3 ± 0.1 [0.012]
- ※ Pin terminal material : Copper alloy
- ※ Plating treatment of terminal : Lead free plating
- ※ Case thickness : 0.2 ± 0.05 [0.008]
- ※ Case material : Brass
- ※ Plating treatment of case : Nickel plating
- ※ Please keep enough creepage distance with the pattern on PCB and other components.
- ※ Weight : 11g max

※ Back View

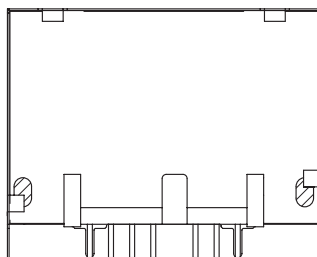

▨ : Conduction Area

Closeup of part A

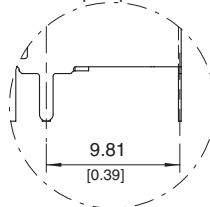

Closeup of part B

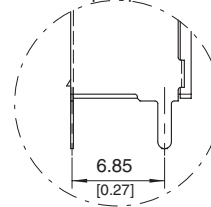

SUTW6

SUT W 6 12 12 - □

① ② ③ ④ ⑤ ⑥

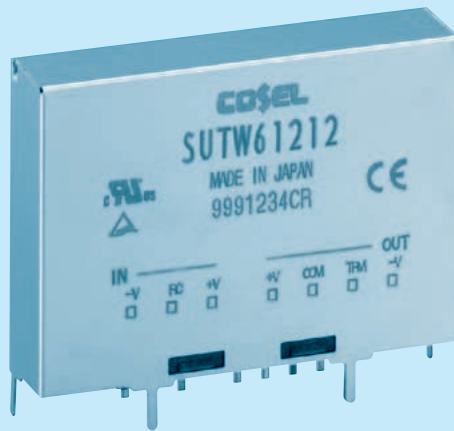
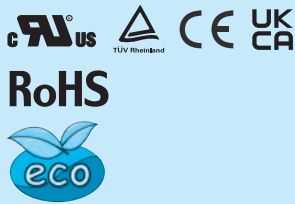

- ① Series name
- ② Dual output
- ③ Output wattage
- ④ Input voltage
- ⑤ Output voltage
- ⑥ Optional
- G :Capacitor between Input and Output is removed.

MODEL	SUTW60512	SUTW60515	SUTW61212	SUTW61215	SUTW62412	SUTW62415	SUTW64812	SUTW64815	
MAX OUTPUT WATTAGE[W]	6	6	6	6	6	6	6	6	
DC OUTPUT	VOLTAGE[V] *1	± 12 or +24	± 15 or +30	± 12 or +24	± 15 or +30	± 12 or +24	± 15 or +30	± 12 or +24	± 15 or +30
	CURRENT[A]	0.25	0.2	0.25	0.2	0.25	0.2	0.25	0.2

SPECIFICATIONS

	MODEL	SUTW60512	SUTW60515	SUTW61212	SUTW61215	SUTW62412	SUTW62415	SUTW64812	SUTW64815	
INPUT	VOLTAGE[V]	DC4.5 - 9		DC9 - 18		DC18 - 36		DC36 - 76		
	CURRENT[A] *2	1.538typ	1.538typ	0.588typ	0.588typ	0.291typ	0.291typ	0.145typ	0.145typ	
	EFFICIENCY[%] *2	78typ	78typ	85typ	85typ	86typ	86typ	86typ	86typ	
OUTPUT	VOLTAGE[V]	± 12(+24)	± 15(+30)	± 12(+24)	± 15(+30)	± 12(+24)	± 15(+30)	± 12(+24)	± 15(+30)	
	CURRENT[A]	0.25	0.2	0.25	0.2	0.25	0.2	0.25	0.2	
	LINE REGULATION[mV]	60max	75max	60max	75max	60max	75max	60max	75max	
	LOAD REGULATION[mV]	600max	750max	600max	750max	600max	750max	600max	750max	
	RIPPLE[mVp-p]	-20 to +55°C *3	120max	120max	120max	120max	120max	120max	120max	120max
		-40 to -20°C *3	150max	150max	150max	150max	150max	150max	150max	150max
	RIPPLE NOISE[mVp-p]	-20 to +55°C *3	150max	150max	150max	150max	150max	150max	150max	150max
		-40 to -20°C *3	200max	200max	200max	200max	200max	200max	200max	200max
	TEMPERATURE REGULATION[mV]	-20 to +55°C	150max	180max	150max	180max	150max	180max	150max	180max
		-40 to +55°C	240max	290max	240max	290max	240max	290max	240max	290max
DRIFT[mV] *4	50max	60max	50max	60max	50max	60max	50max	60max		
START-UP TIME[ms]	20max (Minimum input, Io=100%)									
OUTPUT VOLTAGE ADJUSTMENT RANGE	Fixed (TRM pin open) ±5% adjustable by external VR									
OUTPUT VOLTAGE SETTING[V] (±5%)	11.40 - 12.60	14.25 - 15.75	11.40 - 12.60	14.25 - 15.75	11.40 - 12.60	14.25 - 15.75	11.40 - 12.60	14.25 - 15.75	11.40 - 12.60	
PROTECTION CIRCUIT AND OTHERS	OVERCURRENT PROTECTION	Works over 105% of rating and recovers automatically								
	REMOTE ON/OFF	Provided (Negative logic L : ON, H : OFF)								
ISOLATION	INPUT-OUTPUT	AC500V 1minute, Cutoff current = 10mA, DC500V 50MΩ min (20±15°C)								
	INPUT-CASE	AC500V 1minute, Cutoff current = 10mA, DC500V 50MΩ min (20±15°C)								
	OUTPUT-CASE	AC500V 1minute, Cutoff current = 10mA, DC500V 50MΩ min (20±15°C)								
ENVIRONMENT	OPERATING TEMP., HUMID. AND ALTITUDE	-40 to +85°C, 20 - 95%RH (Non condensing) (Refer to "Derating"), 3,000m (10,000feet) max								
	STORAGE TEMP., HUMID. AND ALTITUDE	-40 to +100°C, 20 - 95%RH (Non condensing), 9,000m (30,000feet) max								
	VIBRATION	10 - 55Hz, 98.0m/s ² (10G), 3minutes period, 60minutes each along X, Y and Z axis								
	IMPACT	490.3m/s ² (50G), 11ms, once each along X, Y and Z axis								
SAFETY	AGENCY APPROVALS	UL60950-1, C-UL, EN62368-1								
OTHERS	CASE SIZE/WEIGHT	37.6 × 26.4 × 9.15mm [1.84 × 1.04 × 0.36 inches] (W × H × D) / 11g max								
	COOLING METHOD	Convection/Forced air								

*1 Output pins can be connected in series to make a 24V/30V output.
 *2 Rated input 5V, 12V, 24V or 48V DC Io=100%
 *3 Ripple and Ripple Noise is measured by using measuring board with capacitor with in 25mm from output pin terminals.
 *4 Drift is the change in DC output for an eight hour period after a half-hour warm-up at 25°C.
 * Parallel operation with other model is not possible.

External view

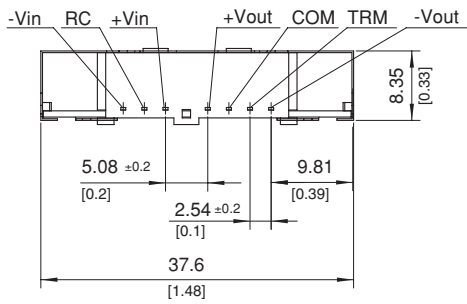
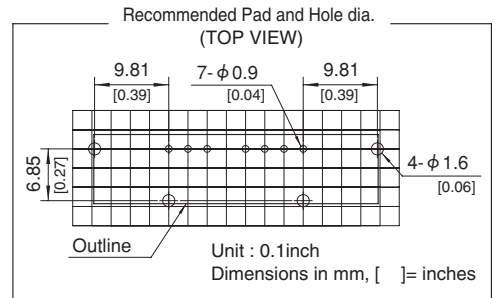
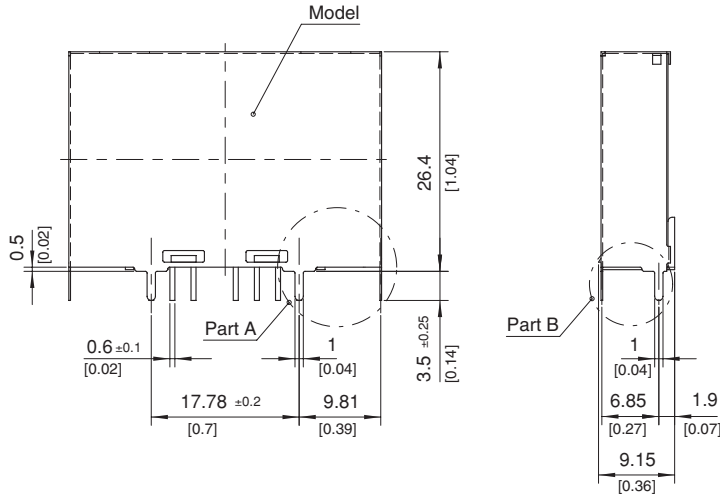

- ※ Tolerance ± 0.5 [± 0.02]
- ※ Dimensions in mm, []= inches
- ※ Pin terminal thickness : 0.3 ± 0.1 [0.012]
- ※ Pin terminal material : Copper alloy
- ※ Plating treatment of terminal : Lead free plating
- ※ Case thickness : 0.2 ± 0.05 [0.008]
- ※ Case material : Brass
- ※ Plating treatment of case : Nickel plating
- ※ Please keep enough creepage distance with the pattern on PCB and other components.
- ※ Weight : 11g max

※ Back View

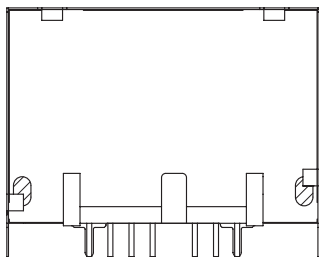

: Conduction Area

Closeup of part A

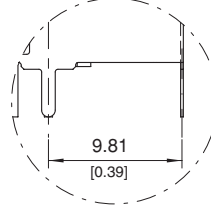

Closeup of part B

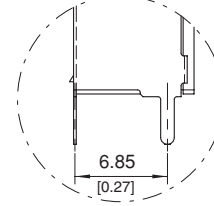

SUTS10

SUT S 10 12 05 - □

① ② ③ ④ ⑤ ⑥

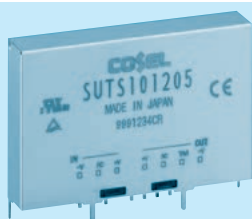

① Series name
 ② Single output
 ③ Output wattage
 ④ Input voltage
 ⑤ Output voltage
 ⑥ Optional
 G :Capacitor between Input and Output is removed.

MODEL	SUTS10053R3	SUTS100505	SUTS100512	SUTS100515	SUTS10123R3	SUTS101205	SUTS101212	SUTS101215
MAX OUTPUT WATTAGE[W]	8.58	10	10.8	10.5	8.58	10	12	12
DC OUTPUT	VOLTAGE[V] *1	3.3	5	12	15	3.3	5	12
	CURRENT[A]	2.6	2	0.9	0.7	2.6	2	1

SPECIFICATIONS

	MODEL	SUTS10053R3	SUTS100505	SUTS100512	SUTS100515	SUTS10123R3	SUTS101205	SUTS101212	SUTS101215	
INPUT	VOLTAGE[V]	DC4.5 - 9				DC9 - 18				
	CURRENT[A] *2	2.12typ	2.41typ	2.54typ	2.47typ	0.872typ	0.980typ	1.15typ	1.15typ	
	EFFICIENCY[%] *2	81typ	83typ	85typ	85typ	82typ	85typ	87typ	87typ	
OUTPUT	VOLTAGE[V]	3.3	5	12	15	3.3	5	12	15	
	CURRENT[A]	2.6	2	0.9	0.7	2.6	2	1	0.8	
	LINE REGULATION[mV]	20max	20max	48max	60max	20max	20max	48max	60max	
	LOAD REGULATION[mV]	40max	40max	100max	120max	40max	40max	100max	120max	
	RIPPLE[mVp-p]	-20 to +55°C *3	80max	80max	120max	120max	80max	80max	120max	120max
		-40 to -20°C *3	120max	120max	150max	150max	120max	120max	150max	150max
	RIPPLE NOISE[mVp-p]	-20 to +55°C *3	120max	120max	150max	150max	120max	120max	150max	150max
		-40 to -20°C *3	200max	200max	200max	200max	200max	200max	200max	200max
	TEMPERATURE REGULATION[mV]	-20 to +55°C	50max	50max	150max	180max	50max	50max	150max	180max
		-40 to +55°C	80max	80max	240max	290max	80max	80max	240max	290max
	DRIFT[mV] *4	20max	20max	48max	60max	20max	20max	48max	60max	
START-UP TIME[ms]	20max (Minimum input, Io=100%)									
OUTPUT VOLTAGE ADJUSTMENT RANGE	Fixed (TRM pin open) ±5% adjustable by external VR									
OUTPUT VOLTAGE SETTING[V] (±3%)	3.21 - 3.42	4.90 - 5.21	11.64 - 12.36	14.55 - 15.45	3.21 - 3.42	4.90 - 5.21	11.64 - 12.36	14.55 - 15.45		
PROTECTION CIRCUIT AND OTHERS	OVERCURRENT PROTECTION	Works over 105% of rating and recovers automatically								
	REMOTE ON/OFF	Provided (Negative logic L : ON, H : OFF)								

MODEL	SUTS10243R3	SUTS102405	SUTS102412	SUTS102415	SUTS10483R3	SUTS104805	SUTS104812	SUTS104815
MAX OUTPUT WATTAGE[W]	8.58	10	12	12	8.58	10	12	12
DC OUTPUT	VOLTAGE[V] *1	3.3	5	12	15	3.3	5	12
	CURRENT[A]	2.6	2	1	0.8	2.6	2	1

SPECIFICATIONS

	MODEL	SUTS10243R3	SUTS102405	SUTS102412	SUTS102415	SUTS10483R3	SUTS104805	SUTS104812	SUTS104815	
INPUT	VOLTAGE[V]	DC18 - 36				DC36 - 76				
	CURRENT[A] *2	0.436typ	0.490typ	0.575typ	0.575typ	0.218typ	0.245typ	0.287typ	0.287typ	
	EFFICIENCY[%] *2	82typ	85typ	87typ	87typ	82typ	85typ	87typ	87typ	
OUTPUT	VOLTAGE[V]	3.3	5	12	15	3.3	5	12	15	
	CURRENT[A]	2.6	2	1	0.8	2.6	2	1	0.8	
	LINE REGULATION[mV]	20max	20max	48max	60max	20max	20max	48max	60max	
	LOAD REGULATION[mV]	40max	40max	100max	120max	40max	40max	100max	120max	
	RIPPLE[mVp-p]	-20 to +55°C *3	80max	80max	120max	120max	80max	80max	120max	120max
		-40 to -20°C *3	120max	120max	150max	150max	120max	120max	150max	150max
	RIPPLE NOISE[mVp-p]	-20 to +55°C *3	120max	120max	150max	150max	120max	120max	150max	150max
		-40 to -20°C *3	200max	200max	200max	200max	200max	200max	200max	200max
	TEMPERATURE REGULATION[mV]	-20 to +55°C	50max	50max	150max	180max	50max	50max	150max	180max
		-40 to +55°C	80max	80max	240max	290max	80max	80max	240max	290max
	DRIFT[mV] *4	20max	20max	48max	60max	20max	20max	48max	60max	
START-UP TIME[ms]	20max (Minimum input, Io=100%)									
OUTPUT VOLTAGE ADJUSTMENT RANGE	Fixed (TRM pin open) ±5% adjustable by external VR									
OUTPUT VOLTAGE SETTING[V] (±3%)	3.21 - 3.42	4.90 - 5.21	11.64 - 12.36	14.55 - 15.45	3.21 - 3.42	4.90 - 5.21	11.64 - 12.36	14.55 - 15.45		
PROTECTION CIRCUIT AND OTHERS	OVERCURRENT PROTECTION	Works over 105% of rating and recovers automatically								
	REMOTE ON/OFF	Provided (Negative logic L : ON, H : OFF)								

GENERAL SPECIFICATIONS

ISOLATION	INPUT-OUTPUT	AC500V 1minute, Cutoff current = 10mA, DC500V 50M Ω min (20 \pm 15 $^{\circ}$ C)
	INPUT-CASE	AC500V 1minute, Cutoff current = 10mA, DC500V 50M Ω min (20 \pm 15 $^{\circ}$ C)
	OUTPUT-CASE	AC500V 1minute, Cutoff current = 10mA, DC500V 50M Ω min (20 \pm 15 $^{\circ}$ C)
ENVIRONMENT	OPERATING TEMP., HUMID. AND ALTITUDE	-40 to +85 $^{\circ}$ C, 20 - 95%RH (Non condensing) (Refer to "Derating"), 3,000m (10,000feet) max
	STORAGE TEMP., HUMID. AND ALTITUDE	-40 to +100 $^{\circ}$ C, 20 - 95%RH (Non condensing), 9,000m (30,000feet) max
	VIBRATION	10 - 55Hz, 98.0m/s 2 (10G), 3minutes period, 60minutes each along X, Y and Z axis
	IMPACT	490.3m/s 2 (50G), 11ms, once each along X, Y and Z axis
SAFETY	AGENCY APPROVALS	UL60950-1, C-UL, EN62368-1
OTHERS	CASE SIZE/WEIGHT	45.2 x 29.3 x 9.15mm [1.78 x 1.15 x 0.36 inches] (W x H x D) / 14g max
	COOLING METHOD	Convection/Forced air

- *1 SUTW10xx12/SUTW10xx15 is available as single output, +24V/+30V.
- *2 Rated input 5V, 12V, 24V or 48V DC Io=100%
- *3 Ripple and Ripple Noise is measured by using measuring board with capacitor with in 25mm from output pin terminals.
- *4 Drift is the change in DC output for an eight hour period after a half-hour warm-up at 25 $^{\circ}$ C.
- * Parallel operation with other model is not possible.

External view

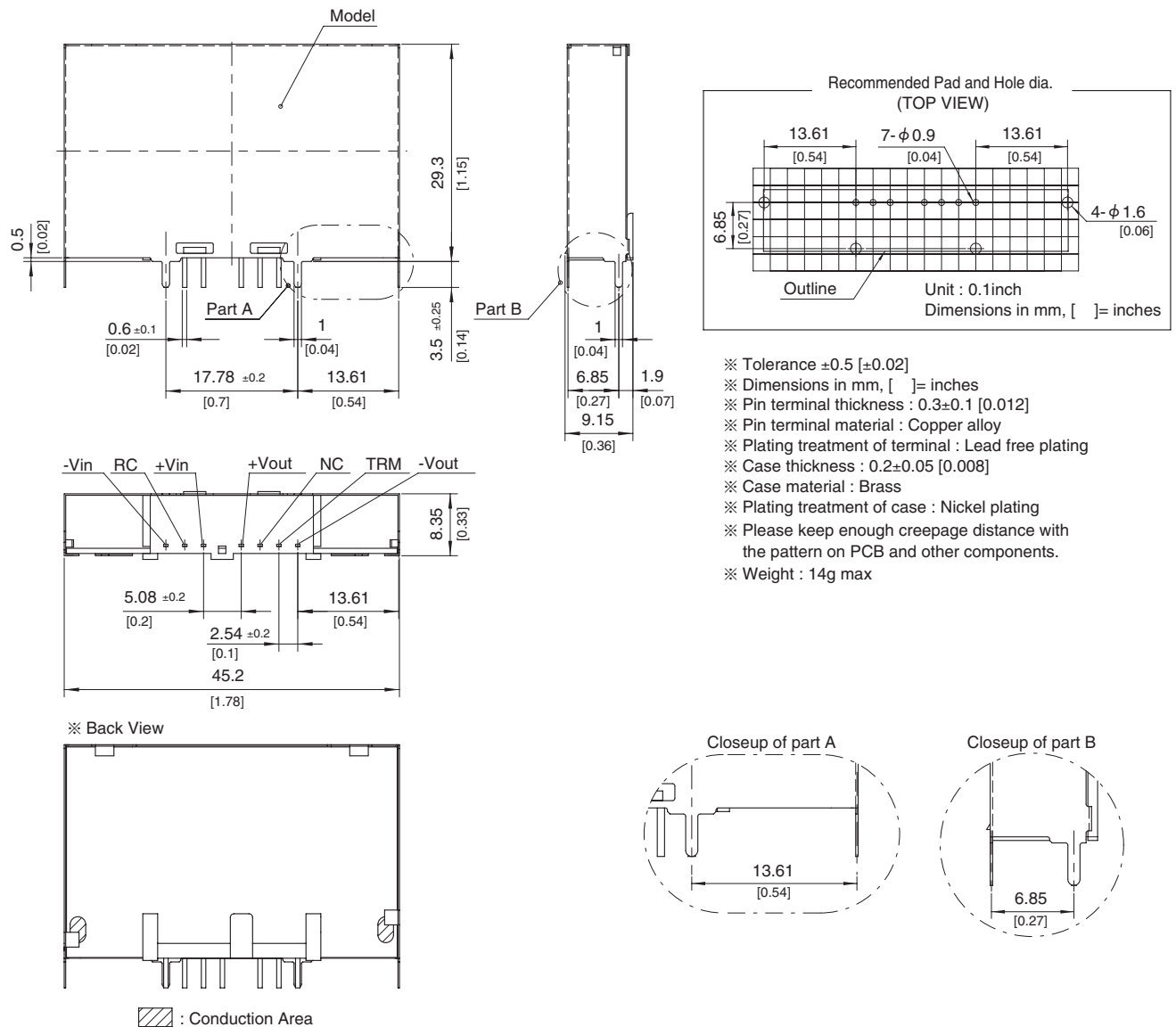

SUTW10

SUT W 10 12 12 - □

① ② ③ ④ ⑤ ⑥

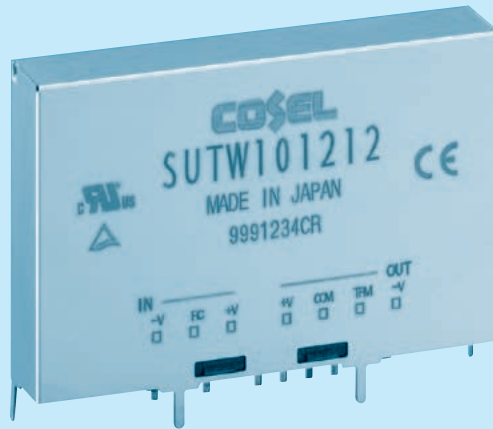
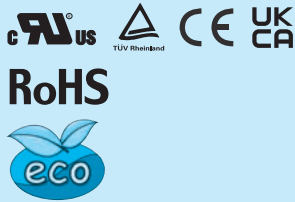

- ① Series name
- ② Dual output
- ③ Output wattage
- ④ Input voltage
- ⑤ Output voltage
- ⑥ Optional
- G : Capacitor between Input and Output is removed.

MODEL	SUTW100512	SUTW100515	SUTW101212	SUTW101215	SUTW102412	SUTW102415	SUTW104812	SUTW104815	
MAX OUTPUT WATTAGE[W]	10.8	10.5	10.8	10.5	10.8	10.5	10.8	10.5	
DC OUTPUT	VOLTAGE[V] *1	±12 or +24	±15 or +30	±12 or +24	±15 or +30	±12 or +24	±15 or +30	±12 or +24	±15 or +30
	CURRENT[A]	0.45	0.35	0.45	0.35	0.45	0.35	0.45	0.35

SPECIFICATIONS

	MODEL	SUTW100512	SUTW100515	SUTW101212	SUTW101215	SUTW102412	SUTW102415	SUTW104812	SUTW104815	
INPUT	VOLTAGE[V]	DC4.5 - 9		DC9 - 18		DC18 - 36		DC36 - 76		
	CURRENT[A] *2	2.51typ	2.44typ	1.05typ	1.02typ	0.523typ	0.509typ	0.262typ	0.254typ	
	EFFICIENCY[%] *2	86typ	86typ	86typ	86typ	86typ	86typ	86typ	86typ	
OUTPUT	VOLTAGE[V]	±12(+24)	±15(+30)	±12(+24)	±15(+30)	±12(+24)	±15(+30)	±12(+24)	±15(+30)	
	CURRENT[A]	0.45	0.35	0.45	0.35	0.45	0.35	0.45	0.35	
	LINE REGULATION[mV]	60max	75max	60max	75max	60max	75max	60max	75max	
	LOAD REGULATION[mV]	600max	750max	600max	750max	600max	750max	600max	750max	
	RIPPLE[mVp-p]	-20 to +55°C *3	120max	120max	120max	120max	120max	120max	120max	120max
		-40 to -20°C *3	150max	150max	150max	150max	150max	150max	150max	150max
	RIPPLE NOISE[mVp-p]	-20 to +55°C *3	150max	150max	150max	150max	150max	150max	150max	150max
		-40 to -20°C *3	200max	200max	200max	200max	200max	200max	200max	200max
	TEMPERATURE REGULATION[mV]	-20 to +55°C	150max	180max	150max	180max	150max	180max	150max	180max
		-40 to +55°C	240max	290max	240max	290max	240max	290max	240max	290max
DRIFT[mV] *4	50max	60max	50max	60max	50max	60max	50max	60max		
START-UP TIME[ms]	20max (Minimum input, Io=100%)									
OUTPUT VOLTAGE ADJUSTMENT RANGE	Fixed (TRM pin open) ±5% adjustable by external VR									
OUTPUT VOLTAGE SETTING[V] (±5%)	11.40 - 12.60	14.25 - 15.75	11.40 - 12.60	14.25 - 15.75	11.40 - 12.60	14.25 - 15.75	11.40 - 12.60	14.25 - 15.75	11.40 - 12.60	
PROTECTION CIRCUIT AND OTHERS	OVERCURRENT PROTECTION	Works over 105% of rating and recovers automatically								
	REMOTE ON/OFF	Provided (Negative logic L : ON, H : OFF)								
ISOLATION	INPUT-OUTPUT	AC500V 1minute, Cutoff current = 10mA, DC500V 50MΩ min (20±15°C)								
	INPUT-CASE	AC500V 1minute, Cutoff current = 10mA, DC500V 50MΩ min (20±15°C)								
	OUTPUT-CASE	AC500V 1minute, Cutoff current = 10mA, DC500V 50MΩ min (20±15°C)								
ENVIRONMENT	OPERATING TEMP., HUMID. AND ALTITUDE	-40 to +85°C, 20 - 95%RH (Non condensing) (Refer to "Derating"), 3,000m (10,000feet) max								
	STORAGE TEMP., HUMID. AND ALTITUDE	-40 to +100°C, 20 - 95%RH (Non condensing), 9,000m (30,000feet) max								
	VIBRATION	10 - 55Hz, 98.0m/s ² (10G), 3minutes period, 60minutes each along X, Y and Z axis								
	IMPACT	490.3m/s ² (50G), 11ms, once each along X, Y and Z axis								
SAFETY	AGENCY APPROVALS	UL60950-1, C-UL, EN62368-1								
OTHERS	CASE SIZE/WEIGHT	45.2 × 29.3 × 9.15mm [1.78 × 1.15 × 0.36 inches] (W × H × D) / 14g max								
	COOLING METHOD	Convection/Forced air								

*1 Output pins can be connected in series to make a 24V/30V output.
 *2 Rated input 5V, 12V, 24V or 48V DC Io=100%
 *3 Ripple and Ripple Noise is measured by using measuring board with capacitor with in 25mm from output pin terminals.
 *4 Drift is the change in DC output for an eight hour period after a half-hour warm-up at 25°C.
 * Parallel operation with other model is not possible.

External view

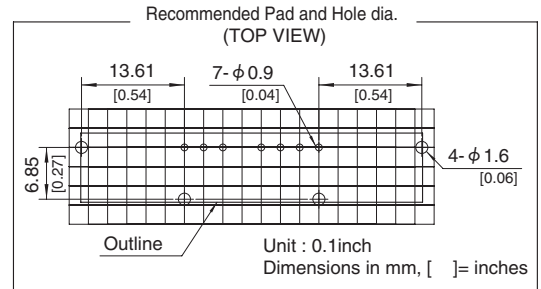
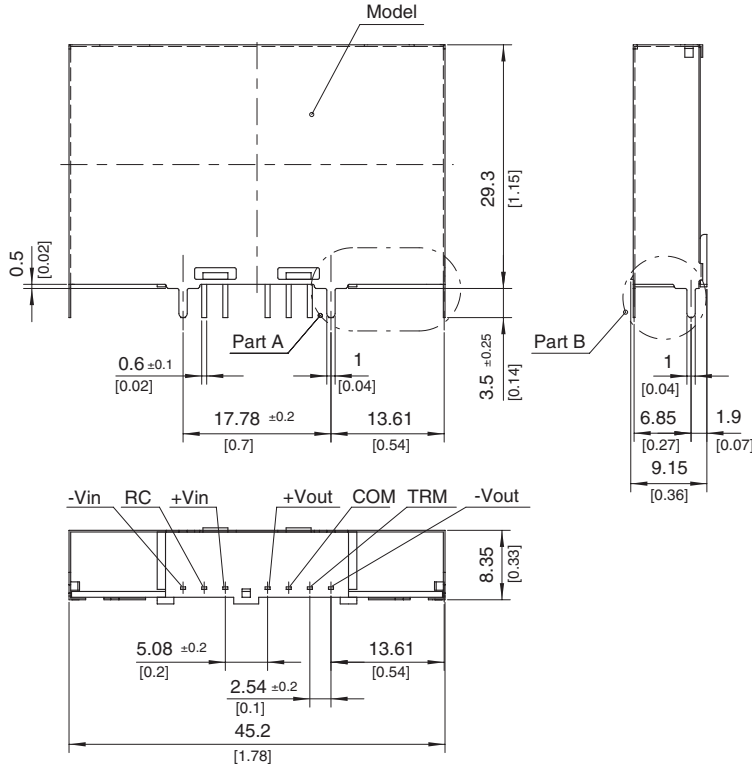

- ※ Tolerance ± 0.5 [± 0.02]
- ※ Dimensions in mm, [] = inches
- ※ Pin terminal thickness : 0.3 ± 0.1 [0.012]
- ※ Pin terminal material : Copper alloy
- ※ Plating treatment of terminal : Lead free plating
- ※ Case thickness : 0.2 ± 0.05 [0.008]
- ※ Case material : Brass
- ※ Plating treatment of case : Nickel plating
- ※ Please keep enough creepage distance with the pattern on PCB and other components.
- ※ Weight : 14g max

※ Back View

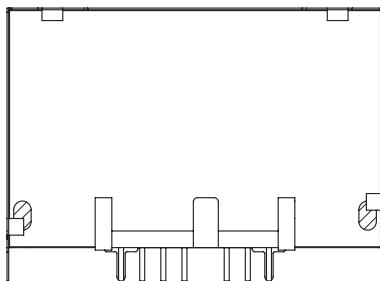

▨ : Conduction Area

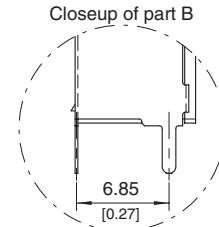
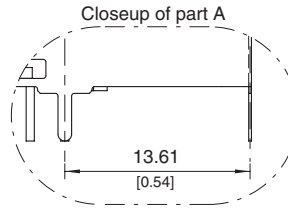

Pin Configuration

● SU/SUC Single Output

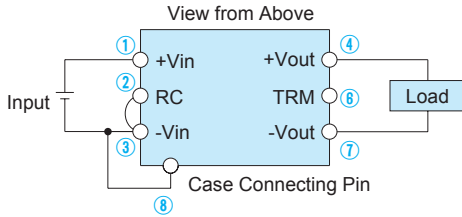

● SU/SUC Dual (\pm) Output

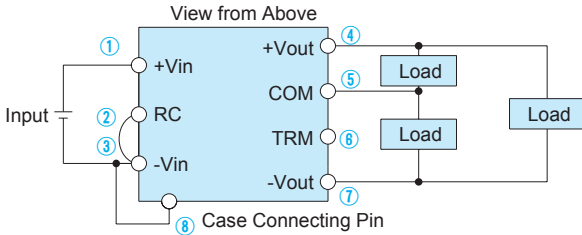

● SU/SUC Single Output, Dual (\pm) Output

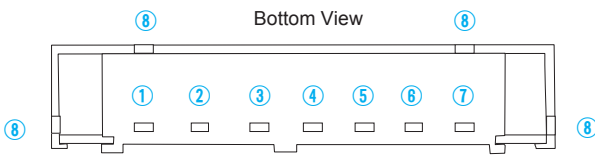

Pin No.	Pin Terminal Name	Function
①	+Vin	+DC Input
②	RC	Remote ON/OFF (excluding 1R5)
③	-Vin	-DC Input
④	+Vout	+DC Output
⑤	COM	GND of Output Voltage (for Dual Output)
⑥	TRM	Output Voltage Adjustment (please see Instruction Manual 1.4)
⑦	-Vout	-DC Output
⑧	Case Connecting Pin	If connected to -Vin, a case potential becomes fixed and radiation noise decreases (applicable only to SUC series).

Pin No.	Pin Terminal Name	Function
①	-Vin	-DC Input
②	RC	Remote ON/OFF
③	+Vin	+DC Input
④	+Vout	+DC Output
⑤	NC (Single output) COM (Dual output)	GND of Output Voltage
⑥	TRM	Output Voltage Adjustment
⑦	-Vout	-DC Output
⑧	Case Connecting Pin	If connected to -Vin, a case potential becomes fixed and radiation noise decreases.

■ Case Connecting Pin Terminal

Units come with a case connecting pin terminal. If this pin terminal is connected to -Vin, radiation noise from the main body decreases. Solder the case connecting pin terminal to PCB to improve reliability.

Assembling and Installation Method

Installation

- You can install the units in any direction. Place them in such a way that there is enough ventilation so that heat does not get accumulated around them.
- Do not place a rand or a pattern layout in the hatched area shown in below. Doing so may cause insulation failure on the PCB surface on which the power supply is mounted.

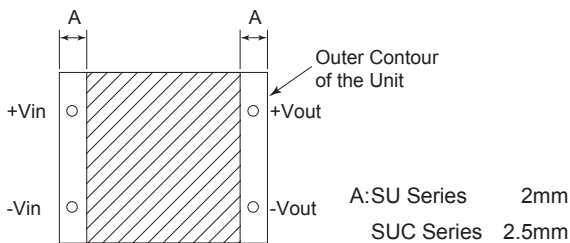

Area where Pattern Layout should not be Placed for SU/SUC

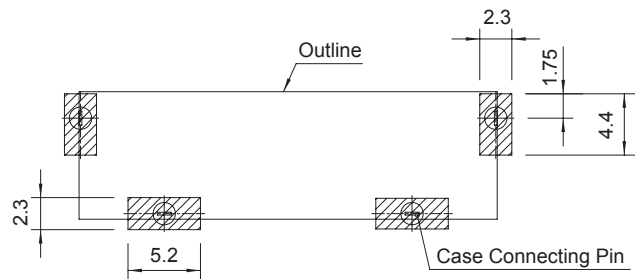

Area where Pattern Layout should not be Placed for SUT

Assembling and Installation Method

Automatic Mounting (TYPE: BP)

■ To mount SU series automatically, use the transformer area near the center of the PCB as a pickup point. To mount SUC series automatically, use the central area of the case as a pickup point. If the bottom dead point of a suction nozzle is too low when mounting, excessive force is applied to the transformer, which could cause damage. Please mount carefully. Please see the External View for details of the pickup point.

Hand Mounting (TYPE: B, C SUT)

- To mount SU series manually, it must be push the transformer placed center of PS.
- To mount SUC series manually, it must be push the center of case.
- Due to prevent failure, PS should not be pull after soldering with PCB.

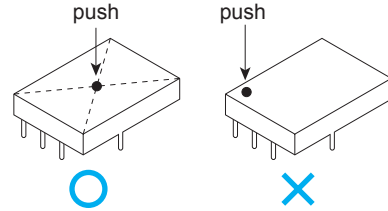

Soldering Conditions

(1) Reflow Soldering (except SUT, SUC□□C-C)

- Right figure shows conditions for the reflow soldering for SU/SUC series. Please make sure that the temperatures of pin terminals +Vin and -Vout shown in right figure . do not exceed the temperatures shown in right figure.
- If time or temperature of the reflow soldering goes beyond the conditions, reliability of internal components may be compromised. Please use the unit under the recommended reflow conditions.
- With this reflow profile, internal solder melts down. When transporting the unit within the reflow oven, please do not give vibration to the unit.
- Please avoid reflow soldering after applying adhesive or coating to the unit.
- You can reflow solder up to 2 times. Do not reflow solder when the power supply is mounted on the back surface of the PCB because the unit may drop.

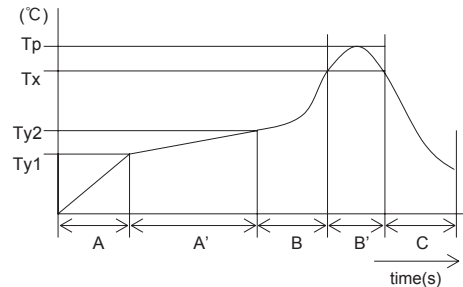
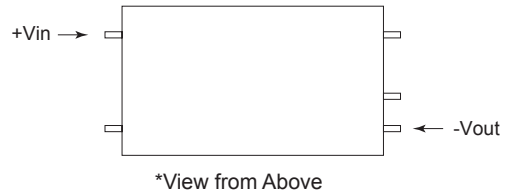

A	1.0 - 5.0°C/s
A'	Ty1 : 160 ±20°C
	Ty2 : 180 ±20°C
	Ty1 - Ty2 : 120s max
B	1.0 - 5.0°C/s
B'	Tp : Max 245°C 10s max
	Tx : 220°C or more : 70s max
C	1.0 - 5.0°C/s

- (2) Flow Soldering : 260°C 15 seconds or less
- (3) Soldering Iron : maximum 360°C 5 seconds or less

Stress to Pin Terminals

- If too much stress is applied to input/output pin terminals of the power supply, internal connection may come down. If you apply stress as shown below, please kept it at 19.6N (2kgf) or less vertically.
- Input/output pin terminals are soldered to the PCB internally. Do not pull or bend a lead powerfully.
- If it is expected that stress is applied to the input/output pin terminals due to vibration or impact, reduce the stress to the pin terminals by taking such measures as fixing the unit to the PCB by silicone rubber, etc.

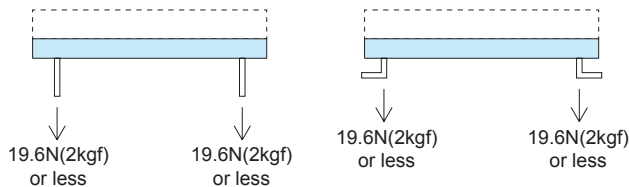

Strength of Input/Output Pin Terminals for SU/SUC

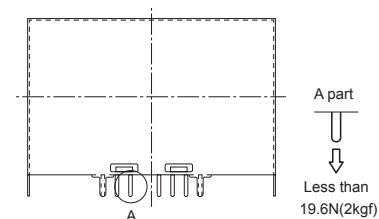

Strength of Input/Output Pin Terminals for SUT

Derating

Ambient temperature derating curve

- It is necessary to note thermal fatigue life by power cycle. Please reduce the temperature fluctuation range as much as possible when the up and down of temperature are frequently generated.
- In the case of forced air cooling, please have sufficient ventilation to keep the temperature of point in Instruction Manual 7. Please also make sure that the ambient temperature does not exceed 85°C.

SU/SUC1R5

(1) In the case of Convection Cooling

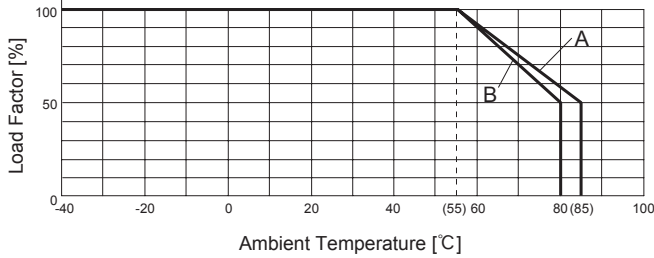

Output Voltage(V) Input Voltage(V)	3.3	5	12	15	±12	±15
5	A	A	A	A	A	A
12	A	A	A	A	A	A
24	A	A	A	A	A	A
48	B	B	B	B	B	B

(2) In the case of Forced Air Cooling (1m/s)

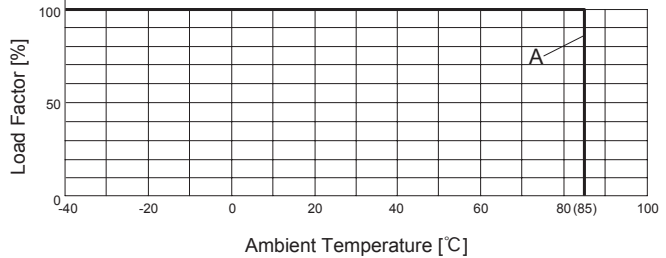

Output Voltage(V) Input Voltage(V)	3.3	5	12	15	±12	±15
5	A	A	A	A	A	A
12	A	A	A	A	A	A
24	A	A	A	A	A	A
48	A	A	A	A	A	A

SU/SUC3

(1) In the case of Convection Cooling

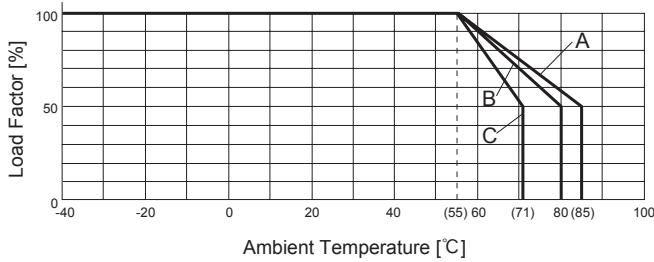

Output Voltage(V) Input Voltage(V)	3.3	5	12	15	±12	±15
5	A	A	B	B	A	B
12	A	A	B	B	A	B
24	A	A	B	B	A	B
48	B	B	B	B	A	C

(2) In the case of Forced Air Cooling (1m/s)

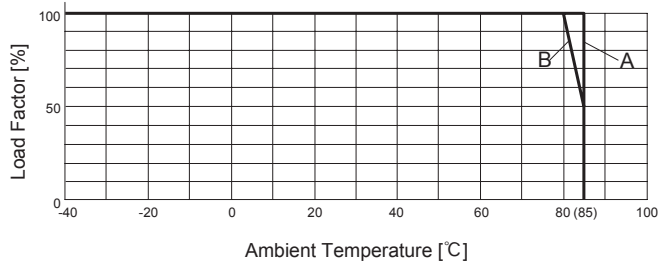

Output Voltage(V) Input Voltage(V)	3.3	5	12	15	±12	±15
5	A	B	B	B	B	B
12	A	A	A	A	A	B
24	A	A	B	A	A	B
48	A	A	A	A	A	B

SU/SUC6

(1) In the case of Convection Cooling

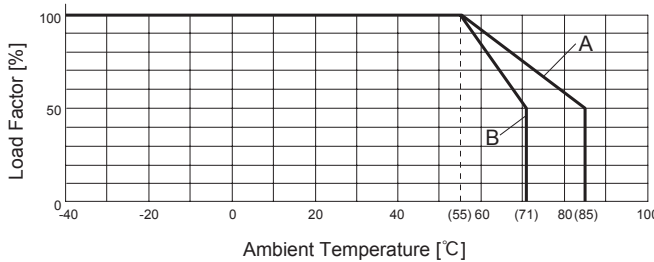

Output Voltage(V) Input Voltage(V)	3.3	5	12	15	±12	±15
5	B	B	B	B	B	B
12	B	B	B	B	B	B
24	B	B	B	B	B	B
48	B	B	A	A	A	A

(2) In the case of Forced Air Cooling (1m/s)

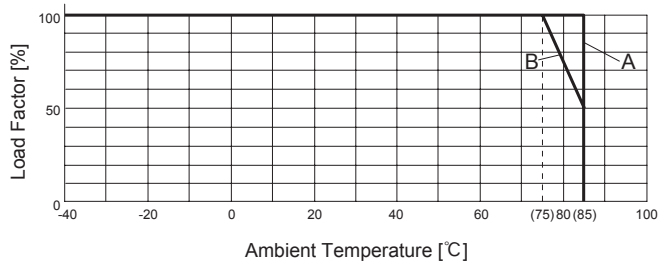

Output Voltage(V) Input Voltage(V)	3.3	5	12	15	±12	±15
5	B	B	A	A	A	A
12	B	B	A	A	A	A
24	B	B	A	A	A	A
48	B	B	A	A	A	A

Derating

● SU/SUC10

(1) In the case of Convection Cooling

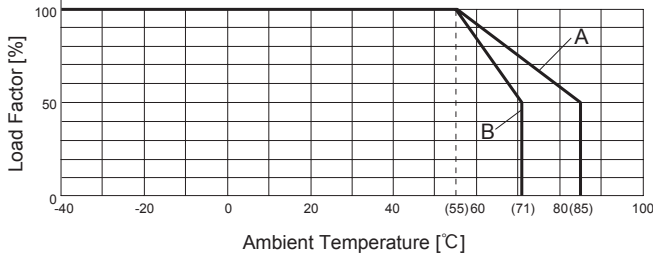

Output Voltage(V) Input Voltage(V)	3.3	5	12	15	±12	±15
5	B	A	A	A	A	A
12	B	A	A	A	A	A
24	B	A	A	A	A	A
48	B	B	B	B	B	B

(2) In the case of Forced Air Cooling (1m/s)

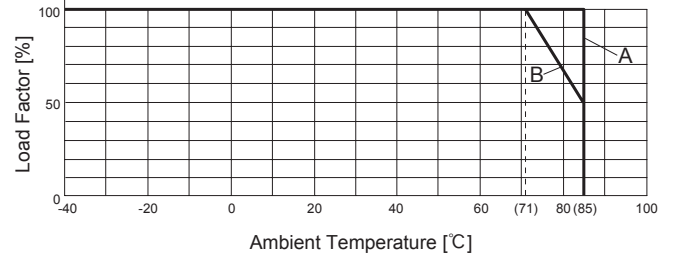

Output Voltage(V) Input Voltage(V)	3.3	5	12	15	±12	±15
5	B	B	B	B	A	A
12	B	B	B	B	A	A
24	B	B	B	B	A	A
48	B	B	B	B	B	B

● SUT3

(1) In the case of Convection Cooling

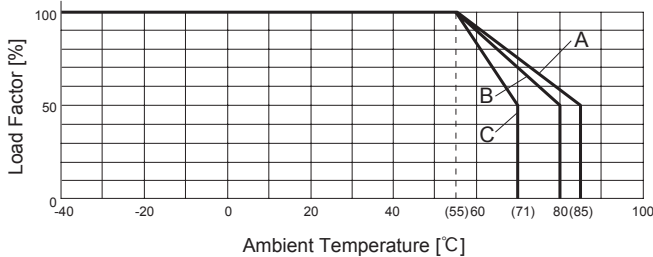

Output Voltage(V) Input Voltage(V)	3.3	5	12	15	±12	±15
5	A	A	B	B	A	B
12	A	A	B	B	A	B
24	A	A	B	B	A	B
48	B	B	B	B	A	C

(2) In the case of Forced Air Cooling (1m/s)

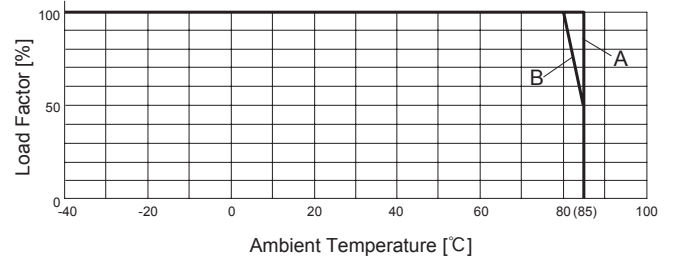

Output Voltage(V) Input Voltage(V)	3.3	5	12	15	±12	±15
5	A	B	B	B	B	B
12	A	A	A	A	A	B
24	A	A	B	A	A	B
48	A	A	A	A	A	B

● SUT6

(1) In the case of Convection Cooling

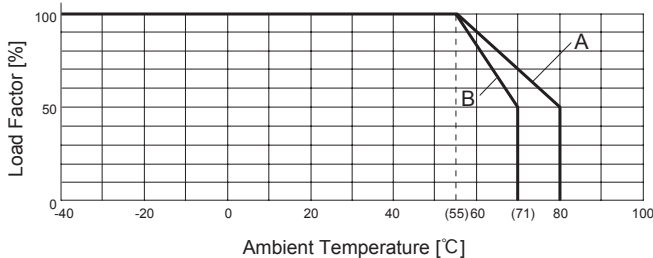

Output Voltage(V) Input Voltage(V)	3.3	5	12	15	±12	±15
5	B	B	B	B	B	B
12	B	B	B	B	B	B
24	B	B	B	B	B	B
48	B	B	A	A	A	A

(2) In the case of Forced Air Cooling (1m/s)

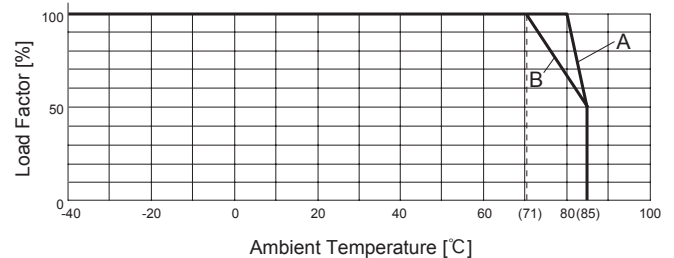

Output Voltage(V) Input Voltage(V)	3.3	5	12	15	±12	±15
5	B	B	B	B	B	B
12	B	B	A	A	A	A
24	B	B	A	A	A	A
48	B	B	A	A	A	A

Derating

SUT10

(1) In the case of Convection Cooling

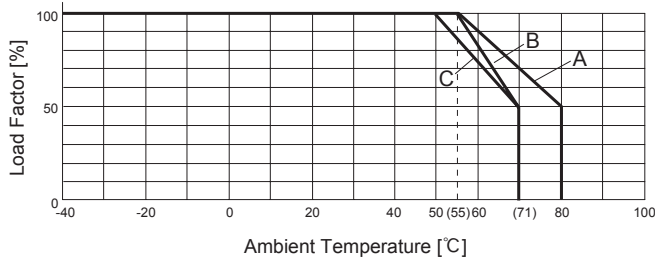

Output Voltage(V) Input Voltage(V)	3.3	5	12	15	±12	±15
5	C	C	A	A	C	C
12	B	A	A	A	B	A
24	C	C	C	C	C	B
48	C	C	C	C	C	C

(2) In the case of Forced Air Cooling (1m/s)

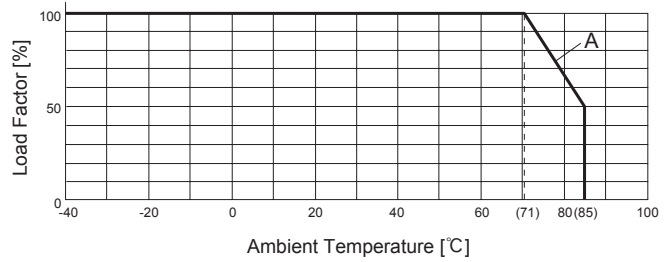

Output Voltage(V) Input Voltage(V)	3.3	5	12	15	±12	±15
5	A	A	A	A	A	A
12	A	A	A	A	A	A
24	A	A	A	A	A	A
48	A	A	A	A	A	A

Instruction Manual

◆ It is necessary to read the "Instruction Manual" and "Before using our product" before you use our product.

Instruction Manual	https://www.cosel.co.jp/redirect/catalog/en/SUS/
Instruction Manual	https://www.cosel.co.jp/redirect/catalog/en/SUW/
Instruction Manual	https://www.cosel.co.jp/redirect/catalog/en/SUCS/
Instruction Manual	https://www.cosel.co.jp/redirect/catalog/en/SUCW/
Instruction Manual	https://www.cosel.co.jp/redirect/catalog/en/SUTS/
Instruction Manual	https://www.cosel.co.jp/redirect/catalog/en/SUTW/
Before using our product	https://en.cosel.co.jp/technical/caution/index.html

SUS



SUCS



SUTS



SUW



SUCW



SUTW



NOTICE



Basic Characteristics Data

Model	Circuit method	Switching frequency [kHz] (reference)	Input current [A]	Inrush current protection	PCB/Pattern			Series/Parallel operation availability	
					Material	Single sided	Double sided	Series operation	Parallel operation
SU/SUC1R5	Flyback converter	350 - 1900	Refer to Table1,2	-	glass fabric base,epoxy resin		Yes	Yes	*1
SU/SUC3	Flyback converter	200 - 1400	Refer to Table1,2	-	glass fabric base,epoxy resin		Yes	Yes	*1
SU/SUC6	Flyback converter	230 - 1950	Refer to Table1,2	-	glass fabric base,epoxy resin		Yes	Yes	*1
SU/SUC10	Flyback converter	250 - 300	Refer to Table1,2	-	glass fabric base,epoxy resin		Yes	Yes	*1
SUT3	Flyback converter	200 - 1400	Refer to Table1,2	-	glass fabric base,epoxy resin		Yes	Yes	*1
SUT6	Flyback converter	230 - 1950	Refer to Table1,2	-	glass fabric base,epoxy resin		Yes	Yes	*1
SUT10	Flyback converter	250 - 300	Refer to Table1,2	-	glass fabric base,epoxy resin		Yes	Yes	*1

*1 Refer to Instruction Manual.

* The value of input current is measured at rated input and load.

Table1 (SUS*** +5V output)

[A]

Output Power	Input Voltage			
	5V	12V	24V	48V
1.5W	0.41	0.16	0.08	0.04
3W	0.78	0.32	0.16	0.08
6W	1.32	0.62	0.31	0.15
10W	2.41	0.98	0.49	0.25

Table2 (SUW*** ±12V output)

[A]

Output Power	Input Voltage			
	5V	12V	24V	48V
1.5W	0.43	0.17	0.09	0.04
3W	0.82	0.33	0.17	0.08
6W	1.54	0.59	0.29	0.15
10W	2.51	1.05	0.52	0.26



Isolated



OCP



OVP

Remote
ON/OFFWide 4 :1
input

STMG-series

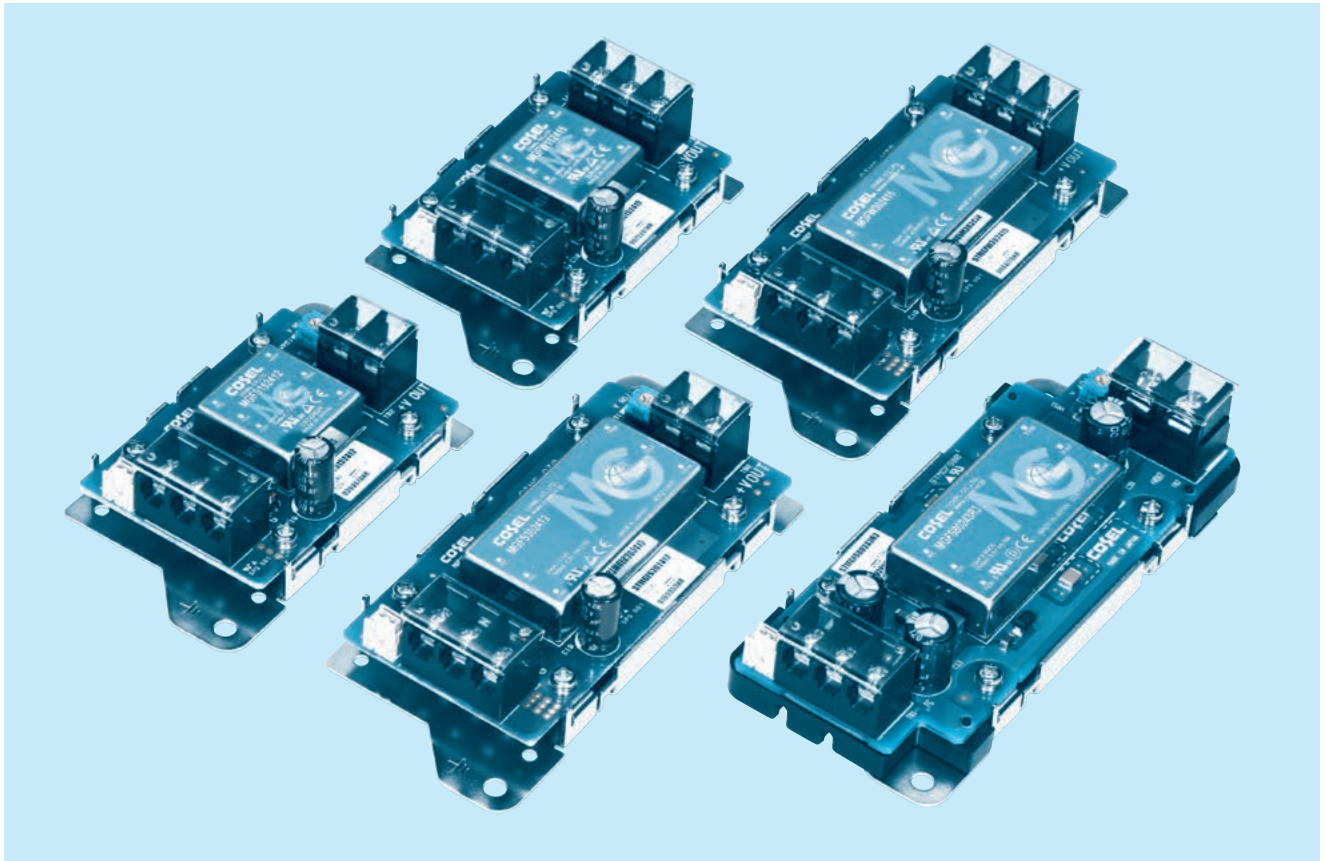

STMG

Feature

- Isolated unit type DC-DC converter
- Wide input voltage DC9-36V/DC18-76V
- Various lineups
- Available connector interface (option)
- Available case cover (option)
- Available DIN rail attachment (option)
- Built in Overcurrent protection (recovery automatically)
- Built in Overvoltage protection (STMG30/STMG80)
- Built in Remote ON/OFF
- Built in Output voltage adjustment (for single output, $\pm 10\%$)

Safety agency approvals

- UL60950-1 C-UL EN62368-1 Complies (STMG15/STMG30)
- UL62368-1 C-UL EN62368-1 Complies (STMG80)

CE marking

- Low voltage Directive
- RoHS Directive

UKCA marking

- Electrical Equipment Safety Regulations
- RoHS Regulations

5-year warranty (refer to Instruction Manual)

STMGFS15

STMGF S 15 24 05 -□

① ② ③ ④ ⑤ ⑥

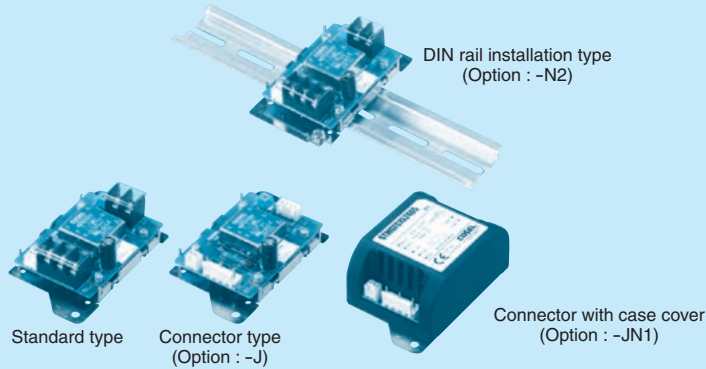

- ① Series name
- ② Single output
- ③ Output wattage
- ④ Input voltage
- ⑤ Output voltage
- ⑥ Optional
 - G : Capacitor between Input and Output is removed.
 - R : with Remote ON/OFF (Positive logic control)
 - J : Input/Output Connector
 - JN1 : Connector with case cover
 - N2 : With DIN rail installation type
 - JN3 : Connector with cover(plastic) and DIN rail installation type
 - V : Output voltage setting potentiometer externally

* Please remove short piece on CN4 to enable remote ON/OFF function.

* When the option is set specifications may vary.

MODEL	STMGFS15243R3	STMGFS152405	STMGFS152412	STMGFS152415
MAX OUTPUT WATTAGE[W]	13.2	15	15.6	15
DC OUTPUT	VOLTAGE[V] *1	3.3	5	12
	CURRENT[A]	4	3	1.3

SPECIFICATIONS

	MODEL	STMGFS15243R3	STMGFS152405	STMGFS152412	STMGFS152415	
INPUT	VOLTAGE[V]	DC9 - 36				
	CURRENT[A] *2	0.63typ	0.71typ	0.73typ	0.70typ	
	EFFICIENCY[%] *2	87typ	88typ	89typ	89typ	
OUTPUT	VOLTAGE[V]	3.3	5	12	15	
	CURRENT[A]	4	3	1.3	1	
	LINE REGULATION[mV]	13.2max	20max	48max	60max	
	LOAD REGULATION[mV]	60max	60max	100max	120max	
	RIPPLE[mVp-p]	0 to +60°C	75max	75max	100max	100max
		*3 -20 to +60°C	100max	100max	120max	120max
	RIPPLE NOISE[mVp-p]	0 to +60°C	120max	120max	150max	150max
		*3 -20 to +60°C	200max	200max	200max	200max
	TEMPERATURE REGULATION[mV]	0 to +60°C	50max	50max	150max	180max
		-20 to +60°C	80max	80max	240max	290max
	DRIFT[mV] *4	20max	20max	48max	60max	
START-UP TIME[ms]	30max (Minimum input, I _o =100%)					
OUTPUT VOLTAGE ADJUSTMENT RANGE	2.97 - 3.63	4.50 - 5.50	10.80 - 13.20	13.50 - 16.50		
OUTPUT VOLTAGE SETTING[V]*5	3.29 - 3.41	4.97 - 5.14	11.85 - 12.25	14.83 - 15.33		
PROTECTION CIRCUIT AND OTHERS	OVERCURRENT PROTECTION	Works over 105% of rating and recovers automatically				
	REMOTE ON/OFF	Provided (Negative logic L:ON, H:OFF)				

MODEL	STMGFS15483R3	STMGFS154805	STMGFS154812	STMGFS154815
MAX OUTPUT WATTAGE[W]	13.2	15	15.6	15
DC OUTPUT	VOLTAGE[V] *1	3.3	5	12
	CURRENT[A]	4	3	1.3

SPECIFICATIONS

	MODEL	STMGFS15483R3	STMGFS154805	STMGFS154812	STMGFS154815	
INPUT	VOLTAGE[V]	DC18 - 76				
	CURRENT[A] *2	0.32typ	0.36typ	0.37typ	0.35typ	
	EFFICIENCY[%] *2	87typ	88typ	88typ	89typ	
OUTPUT	VOLTAGE[V]	3.3	5	12	15	
	CURRENT[A]	4	3	1.3	1	
	LINE REGULATION[mV]	13.2max	20max	48max	60max	
	LOAD REGULATION[mV]	60max	60max	100max	120max	
	RIPPLE[mVp-p]	0 to +60°C	75max	75max	100max	100max
		*3 -20 to +60°C	100max	100max	120max	120max
	RIPPLE NOISE[mVp-p]	0 to +60°C	120max	120max	150max	150max
		*3 -20 to +60°C	200max	200max	200max	200max
	TEMPERATURE REGULATION[mV]	0 to +60°C	50max	50max	150max	180max
		-20 to +60°C	80max	80max	240max	290max
	DRIFT[mV] *4	20max	20max	48max	60max	
START-UP TIME[ms]	30max (Minimum input, I _o =100%)					
OUTPUT VOLTAGE ADJUSTMENT RANGE	2.97 - 3.63	4.50 - 5.50	10.80 - 13.20	13.50 - 16.50		
OUTPUT VOLTAGE SETTING[V]*5	3.29 - 3.41	4.97 - 5.14	11.85 - 12.25	14.83 - 15.33		
PROTECTION CIRCUIT AND OTHERS	OVERCURRENT PROTECTION	Works over 105% of rating and recovers automatically				
	REMOTE ON/OFF	Provided (Negative logic L:ON, H:OFF)				

GENERAL SPECIFICATIONS

ISOLATION	INPUT · RC-OUTPUT	DC1,500V 1minute, Cutoff current = 10mA, DC500V 1,000MΩ min (20±15°C)
	INPUT · RC-FG	DC1,000V 1minute, Cutoff current = 10mA, DC500V 1,000MΩ min (20±15°C)
	OUTPUT-FG	DC1,000V 1minute, Cutoff current = 10mA, DC500V 1,000MΩ min (20±15°C)
ENVIRONMENT	OPERATING TEMP., HUMID. AND ALTITUDE	-20 to +70°C, 20 to 95%RH (Non condensing) (Refer to "Derating"), 3,000m (10,000feet) max
	STORAGE TEMP., HUMID. AND ALTITUDE	-20 to +75°C, 20 to 95%RH (Non condensing), 9,000m (30,000feet) max
	VIBRATION	10 - 55Hz, 19.6m/s ² (2G), 3minutes period, 60minutes each along X, Y and Z axis
	IMPACT	196.1m/s ² (20G), 11ms, once each along X, Y and Z axis
SAFETY	AGENCY APPROVALS	UL60950-1, C-UL, EN62368-1 Complies
OTHERS	CASE SIZE/WEIGHT	52x27x93mm [2.05x1.06x3.66 inches] (W×H×D) / 110g max (When the option is set, refer to the page STMG-4)
	COOLING METHOD	Convection/Forced air

- *1 STMGFW15xx05/STMGFW15xx12/STMGFW15xx15 is available as single output, +10V/+24V/+30V
- *2 Rated input 12V, 24V or 48V DC Io=100%
- *3 Measured by 100MHz oscilloscope or Ripple-Noise meter (Equivalent to KIKUSUI-GIKEN : RM103).
- *4 Drift is the DC output accuracy for eight hours period after a half-hour warm-up at 25°C.
- *5 Rated input voltage (DC24V, DC48V), rated output wattage, ambient temperature at 25°C.
- * Parallel operation with other model is not possible.

External view

Standard type

* External view of option G, R are the same as standard model.
External view of other type options, please refer to the page STMG-4.

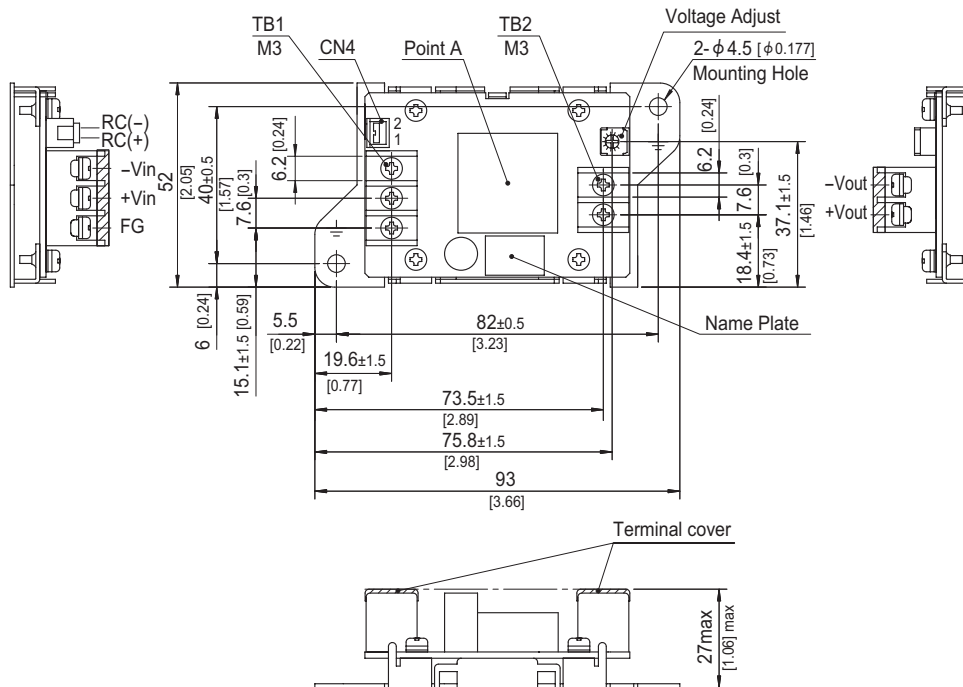

	I/O Connector		Mating Connector	Terminal
Remote ON/OFF	CN4	B2B-XH	XHP-2	Chain : SXH-001T-P0.6 Loose : BXH-001T-P0.6

(Mfr.: J.S.T.)

- * Tolerance ±1 [±0.04]
- * Dimensions in mm, []=inches
- * Weight : 110g max
- * PCB material / thickness : FR-4 / 1.6mm
- * Mounting plate : Iron (surface finishing : nickel plating) / t=1.0mm
- * Terminal block screw tightening torque M3 : 0.8N · m max
- * CN4 has been installed short piece as factory setting (Except option R).
When remote ON/OFF is used, please remove the installed short piece.

External view (Option type)

Connector type (-J)

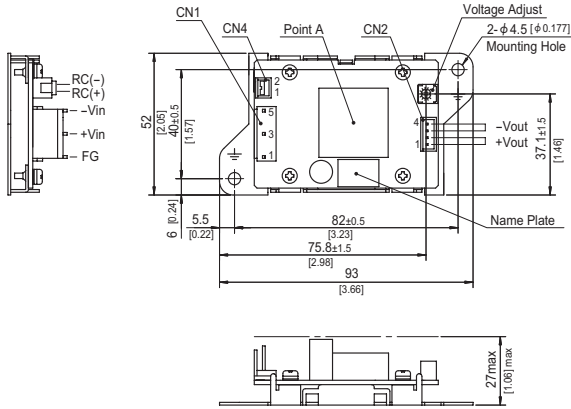

Case cover and connector type (-JN1)

* The specifications of terminal block and Case cover type can not be set.

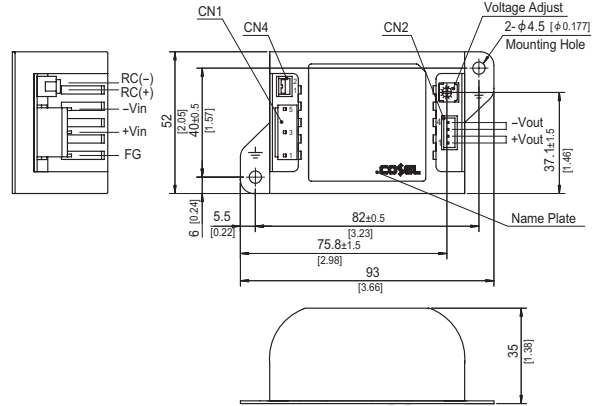

STMG

DIN rail installation type (-N2)

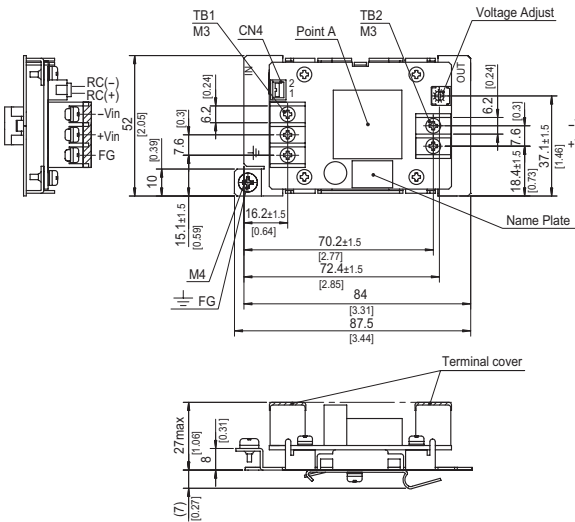

External voltage variable volume type (-V)

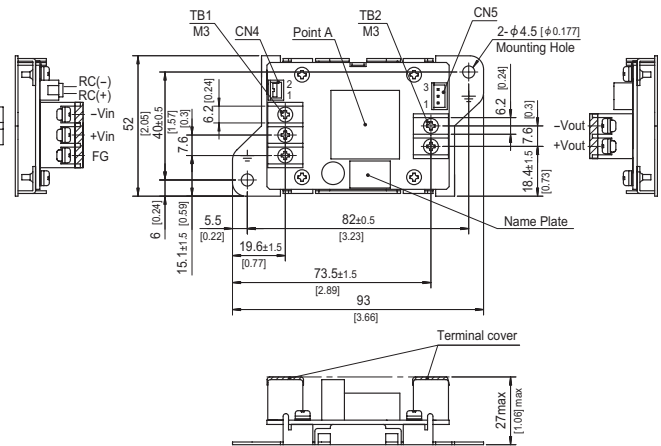

	I/O Connector		Mating Connector	Terminal
Connector Type Input	CN1	B3P5-VH	VHR-5N	Chain : SVH-21T-P1.1 Loose : BVH-21T-P1.1
Connector Type Output	CN2	B4P-XH	XHP-4	Chain : SXH-001T-P0.6 Loose : BXH-001T-P0.6
Remote ON/OFF	CN4	B2B-XH	XHP-2	Chain : SXH-001T-P0.6 Loose : BXH-001T-P0.6
External voltage variable volume type	CN5	B3B-XH	XHP-3	Chain : SXH-001T-P0.6 Loose : BXH-001T-P0.6

(Mfr.:J.S.T.)

- * Tolerance ± 1 [± 0.04]
- * Dimensions in mm, []=inches
- * Weight : Standard & Connector type 110g max
Case cover & DIN rail installation type 120g max
- * PCB material / thickness : FR-4 / 1.6mm
- * Mounting plate : Iron (surface finishing : nickel plating) / t=1.0mm
- * Case : PBT
- * Terminal block screw tightening torque M3 : 0.8N · m max
- * CN4 has been installed jumper as factory setting (Except option R).
When remote ON/OFF is used , please remove the installed jumper.
- * Connector Type : Keep drawing current per pin below 2.5A for CN2.

STMGF15

STMGF W 15 24 05 -□

① ② ③ ④ ⑤ ⑥

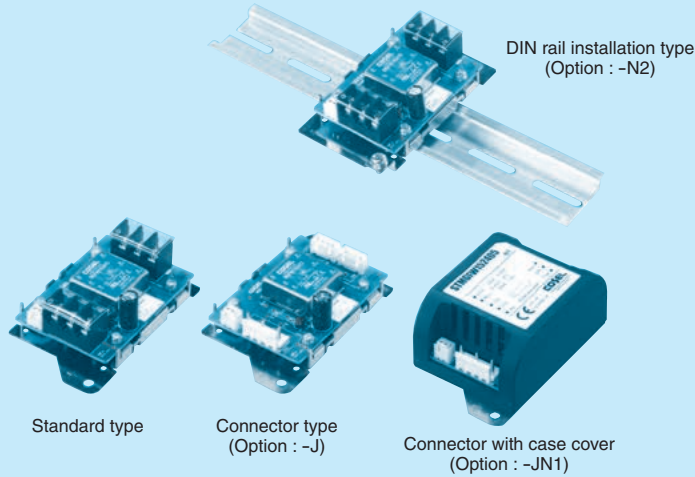

- ① Series name
- ② Dual output
- ③ Output wattage
- ④ Input voltage
- ⑤ Output voltage
- ⑥ Optional
 - G: Capacitor between Input and Output is removed.
 - R: with Remote ON/OFF (Positive logic control)
 - J: Input/Output Connector
 - JN1: Connector with case cover
 - N2: With DIN rail installation type
 - JN3: Connector with cover(plastic) and DIN rail installation type

*When the option is set specifications may vary.

*Please remove short piece on CN4 to enable remote ON/OFF function.

MODEL	STMGF152405	STMGF152412	STMGF152415	STMGF154805	STMGF154812	STMGF154815
MAX OUTPUT WATTAGE[W]	15	15.6	15	15	15.6	15
DC OUTPUT	VOLTAGE[V] *1	±5 or +10	±12 or +24	±15 or +30	±5 or +10	±12 or +24
	CURRENT[A]	1.5	0.65	0.5	1.5	0.65

SPECIFICATIONS

	MODEL	STMGF152405	STMGF152412	STMGF152415	STMGF154805	STMGF154812	STMGF154815	
INPUT	VOLTAGE[V]	DC9 - 36			DC18 - 76			
	CURRENT[A] *2	0.74typ	0.74typ	0.70typ	0.37typ	0.37typ	0.36typ	
	EFFICIENCY[%] *2	84typ	88typ	89typ	84typ	87typ	88typ	
OUTPUT	VOLTAGE[V]	±5(+10)	±12(+24)	±15(+30)	±5(+10)	±12(+24)	±15(+30)	
	CURRENT[A]	1.5	0.65	0.5	1.5	0.65	0.5	
	LINE REGULATION[mV]	40max	60max	75max	40max	60max	75max	
	LOAD REGULATION[mV]	*3	500max *5	600max	750max	500max *5	600max	750max
		*4	250max	480max	600max	250max	480max	600max
	RIPPLE[mVp-p] *6	0 to +60°C	100max	100max	100max	100max	100max	100max
		-20 to +60°C	120max	120max	120max	120max	120max	120max
	RIPPLE NOISE[mVp-p] *6	0 to +60°C	150max	150max	150max	150max	150max	150max
		-20 to +60°C	200max	200max	200max	200max	200max	200max
	TEMPERATURE REGULATION[mV]	0 to +60°C	50max	150max	180max	50max	150max	180max
		-20 to +60°C	80max	240max	290max	80max	240max	290max
DRIFT[mV] *7	50max	50max	60max	50max	50max	60max		
START-UP TIME[ms]	30max (Minimum input, I _o =100%)							
OUTPUT VOLTAGE SETTING[V]*8	4.93 - 5.24	11.76 - 12.50	14.60 - 15.51	4.93 - 5.24	11.76 - 12.50	14.60 - 15.51		
PROTECTION CIRCUIT AND OTHERS	OVERCURRENT PROTECTION	Works over 105% of rating and recovers automatically						
	REMOTE ON/OFF	Provided (Negative logic L:ON, H:OFF)						
ISOLATION	INPUT · RC-OUTPUT	DC1,500V 1minute, Cutoff current = 10mA, DC500V 1,000MΩ min (20±15°C)						
	INPUT · RC-FG	DC1,000V 1minute, Cutoff current = 10mA, DC500V 1,000MΩ min (20±15°C)						
	OUTPUT-FG	DC1,000V 1minute, Cutoff current = 10mA, DC500V 1,000MΩ min (20±15°C)						
ENVIRONMENT	OPERATING TEMP.,HUMID.AND ALTIUDE	-20 to +70°C, 20 to 95%RH (Non condensing) (Refer to "Derating"), 3,000m (10,000feet) max						
	STORAGE TEMP.,HUMID.AND ALTIUDE	-20 to +75°C, 20 to 95%RH (Non condensing), 9,000m (30,000feet) max						
	VIBRATION	10 - 55Hz, 19.6m/s ² (2G), 3minutes period, 60minutes each along X, Y and Z axis						
	IMPACT	196.1m/s ² (20G), 11ms, once each along X, Y and Z axis						
SAFETY	AGENCY APPROVALS	UL60950-1, C-UL, EN62368-1 Complies						
OTHERS	CASE SIZE/WEIGHT	52×27×93mm [2.05×1.06×3.66 inches] (W×H×D) / 110g max (When the option is set, refer to the page STMG-7)						
	COOLING METHOD	Convection/Forced air						

*1 Single output +10V, +24V, +30V with no use of COM.

*2 Rated input 12V, 24V or 48V DC I_o=100%

*3 Symmetrical loading from 5% to 100%.

*4 Symmetrical loading from 20% to 100%.

*5 Refer to the instruction manual 7.

*6 Measured by 100MHz oscilloscope or Ripple-Noise meter (Equivalent to KIKUSUI-GIKEN : RM103).

*7 Drift is the DC output accuracy for eight hours period after a half-hour warm-up at 25°C.

*8 Rated input voltage (DC24V, DC48V), rated output wattage, ambient temperature at 25°C.

* Parallel operation with other model is not possible.

External view

Standard type

* External view of option G, R are the same as standard model.

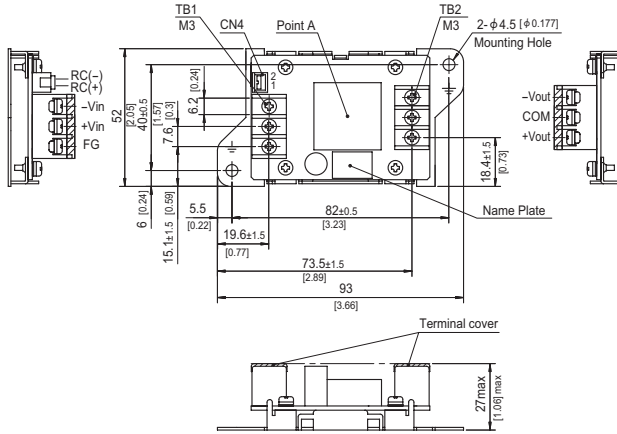

Connector type (-J)

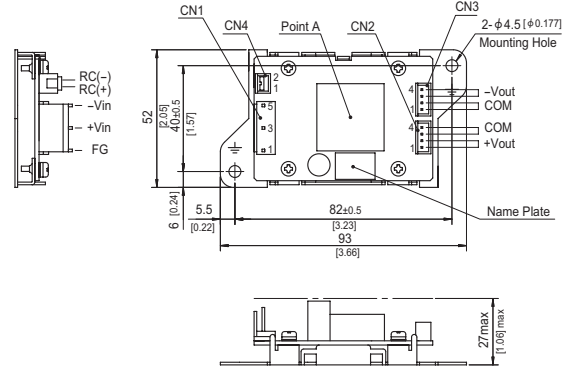

Case cover and connector type (-JN1)

* The specifications of terminal block and Case cover type can not be set.

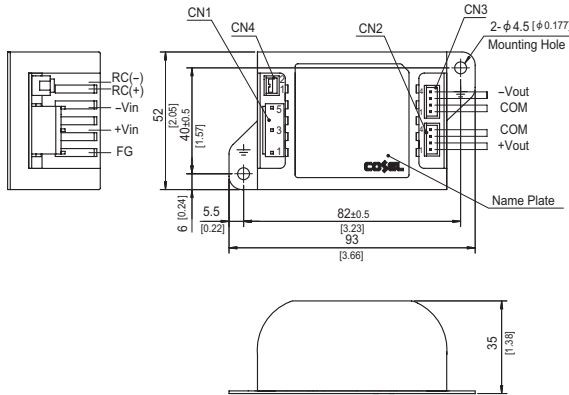

DIN rail installation type (-N2)

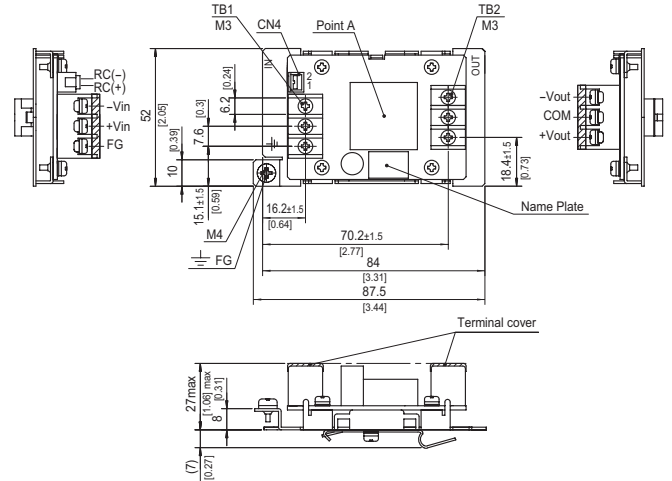

	I/O Connector		Mating Connector	Terminal
Connector Type Input	CN1	B3P5-VH	VHR-5N	Chain : SVH-21T-P1.1 Loose : BVH-21T-P1.1
Connector Type Output	CN2, CN3	B4B-XH	XHP-4	Chain : SXH-001T-P0.6 Loose : BXH-001T-P0.6
Remote ON/OFF	CN4	B2B-XH	XHP-2	Chain : SXH-001T-P0.6 Loose : BXH-001T-P0.6

(Mfr.:J.S.T.)

- * Tolerance ± 1 [± 0.04]
- * Dimensions in mm, []=inches
- * Weight : Standard & Connector type 110g max
Case cover & DIN rail installation type 120g max
- * PCB material / thickness : FR-4 / 1.6mm
- * Mounting plate : Iron (surface finishing : nickel plating) / t=1.0mm
- * Case : PBT
- * Terminal block screw tightening torque M3 : 0.8N · m max
- * CN4 has been installed jumper as factory setting (Except option R).
When remote ON/OFF is used , please remove the installed jumper.
- * Connector Type : Keep drawing current per pin below 2.5A for CN2,CN3.

STMGFS30

STMGF S 30 24 05 -□

① ② ③ ④ ⑤ ⑥

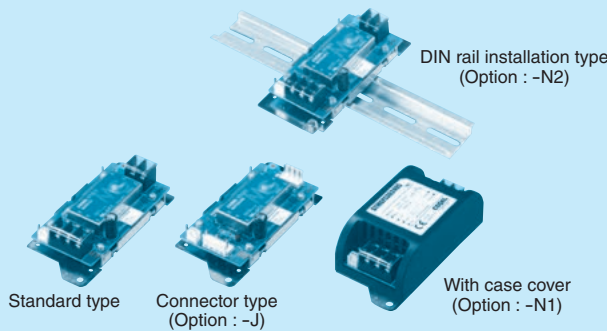

- ① Series name
 - ② Single output
 - ③ Output wattage
 - ④ Input voltage
 - ⑤ Output voltage
 - ⑥ Optional
 - G : Capacitor between Input and Output is removed.
 - R : with Remote ON/OFF (Positive logic control)
 - J : Input/Output Connector
 - N1 : With case cover
 - N2 : With DIN rail installation type
 - N3 : With cover(plastic) and DIN rail installation type
 - V : Output voltage setting potentiometer externally
- *When the option is set specifications may vary.

*Please remove short piece on CN4 to enable remote ON/OFF function.

MODEL	STMGFS30243R3	STMGFS302405	STMGFS302412	STMGFS302415
MAX OUTPUT WATTAGE[W]	24.75	30	30	30
DC OUTPUT	VOLTAGE[V] *1	3.3	5	12
	CURRENT[A]	7.5	6	2.5

SPECIFICATIONS

	MODEL	STMGFS30243R3	STMGFS302405	STMGFS302412	STMGFS302415	
INPUT	VOLTAGE[V]	DC9 - 36				
	CURRENT[A] *2	1.16typ	1.39typ	1.40typ	1.40typ	
	EFFICIENCY[%] *2	89typ	90typ	89typ	89typ	
OUTPUT	VOLTAGE[V]	3.3	5	12	15	
	CURRENT[A]	7.5	6	2.5	2	
	LINE REGULATION[mV]	13.2max	20max	48max	60max	
	LOAD REGULATION[mV]	60max	60max	100max	120max	
	RIPPLE[mVp-p] *3	0 to +60°C	75max	75max	100max	100max
		-20 to +60°C	100max	100max	120max	120max
	RIPPLE NOISE[mVp-p] *3	0 to +60°C	120max	120max	150max	150max
		-20 to +60°C	200max	200max	200max	200max
	TEMPERATURE REGULATION[mV]	0 to +60°C	50max	50max	150max	180max
		-20 to +60°C	80max	80max	240max	290max
	DRIFT[mV] *4	20max	20max	48max	60max	
START-UP TIME[ms]	30max (Minimum input, I _o =100%)					
OUTPUT VOLTAGE ADJUSTMENT RANGE	2.97 - 3.63	4.50 - 5.50	10.80 - 13.20	13.50 - 16.50		
OUTPUT VOLTAGE SETTING[V]*5	3.29 - 3.41	4.97 - 5.14	11.85 - 12.25	14.83 - 15.33		
PROTECTION CIRCUIT AND OTHERS	OVERCURRENT PROTECTION	Works over 105% of rating and recovers automatically				
	OVERVOLTAGE PROTECTION[V]	Works over 120 to 160% of rating				
	REMOTE ON/OFF	Provided (Negative logic L:ON, H:OFF)				

MODEL	STMGFS30483R3	STMGFS304805	STMGFS304812	STMGFS304815
MAX OUTPUT WATTAGE[W]	24.75	30	30	30
DC OUTPUT	VOLTAGE[V] *1	3.3	5	12
	CURRENT[A]	7.5	6	2.5

SPECIFICATIONS

	MODEL	STMGFS30483R3	STMGFS304805	STMGFS304812	STMGFS304815	
INPUT	VOLTAGE[V]	DC18 - 76				
	CURRENT[A] *2	0.58typ	0.70typ	0.70typ	0.70typ	
	EFFICIENCY[%] *2	89typ	90typ	89typ	89typ	
OUTPUT	VOLTAGE[V]	3.3	5	12	15	
	CURRENT[A]	7.5	6	2.5	2	
	LINE REGULATION[mV]	13.2max	20max	48max	60max	
	LOAD REGULATION[mV]	60max	60max	100max	120max	
	RIPPLE[mVp-p] *3	0 to +60°C	75max	75max	100max	100max
		-20 to +60°C	100max	100max	120max	120max
	RIPPLE NOISE[mVp-p] *3	0 to +60°C	120max	120max	150max	150max
		-20 to +60°C	200max	200max	200max	200max
	TEMPERATURE REGULATION[mV]	0 to +60°C	50max	50max	150max	180max
		-20 to +60°C	80max	80max	240max	290max
	DRIFT[mV] *4	20max	20max	48max	60max	
START-UP TIME[ms]	30max (Minimum input, I _o =100%)					
OUTPUT VOLTAGE ADJUSTMENT RANGE	2.97 - 3.63	4.50 - 5.50	10.80 - 13.20	13.50 - 16.50		
OUTPUT VOLTAGE SETTING[V]*5	3.29 - 3.41	4.97 - 5.14	11.85 - 12.25	14.83 - 15.33		
PROTECTION CIRCUIT AND OTHERS	OVERCURRENT PROTECTION	Works over 105% of rating and recovers automatically				
	OVERVOLTAGE PROTECTION[V]	Works over 120 to 160% of rating				
	REMOTE ON/OFF	Provided (Negative logic L:ON, H:OFF)				

GENERAL SPECIFICATIONS

ISOLATION	INPUT · RC-OUTPUT	DC1,500V 1minute, Cutoff current = 10mA, DC500V 1,000MΩ min (20±15°C)
	INPUT · RC-FG	DC1,000V 1minute, Cutoff current = 10mA, DC500V 1,000MΩ min (20±15°C)
	OUTPUT-FG	DC1,000V 1minute, Cutoff current = 10mA, DC500V 1,000MΩ min (20±15°C)
ENVIRONMENT	OPERATING TEMP., HUMID. AND ALTITUDE	-20 to +70°C, 20 to 95%RH (Non condensing) (Refer to "Derating"), 3,000m (10,000feet) max
	STORAGE TEMP., HUMID. AND ALTITUDE	-20 to +75°C, 20 to 95%RH (Non condensing), 9,000m (30,000feet) max
	VIBRATION	10 - 55Hz, 19.6m/s ² (2G), 3minutes period, 60minutes each along X, Y and Z axis
	IMPACT	196.1m/s ² (20G), 11ms, once each along X, Y and Z axis
SAFETY	AGENCY APPROVALS	UL60950-1, C-UL, EN62368-1 Complies
OTHERS	CASE SIZE/WEIGHT	52x27x117mm [2.05x1.06x4.61 inches] (W×H×D) / 140g max (When the option is set, refer to the page STMG-10)
	COOLING METHOD	Convection/Forced air

- *1 STMGFW30xx05/STMGFW30xx12/STMGFW30xx15 is available as single output, +10V/+24V/+30V
- *2 Rated input 12V, 24V or 48V DC Io=100%
- *3 Measured by 100MHz oscilloscope or Ripple-Noise meter (Equivalent to KIKUSUI-GIKEN : RM103).
- *4 Drift is the DC output accuracy for eight hours period after a half-hour warm-up at 25°C.
- *5 Rated input voltage (DC24V, DC48V), rated output wattage, ambient temperature at 25°C.
- * Parallel operation with other model is not possible.

External view

Standard type

* External view of option G, R are the same as standard model.
External view of other type options, please refer to the page STMG-10.

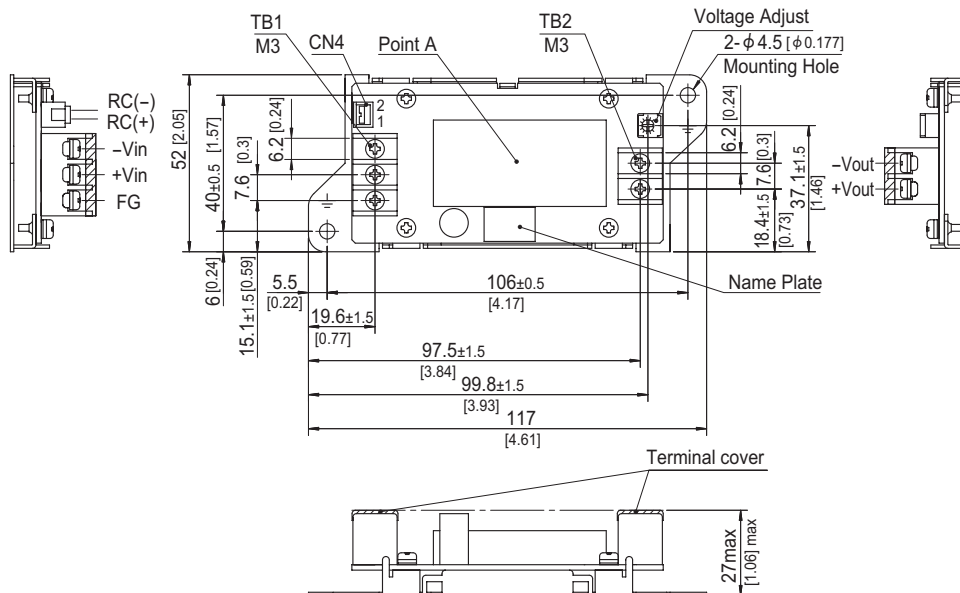

	I/O Connector		Mating Connector	Terminal
Remote ON/OFF	CN4	B2B-XH	XHP-2	Chain : SXH-001T-P0.6 Loose : BXH-001T-P0.6

(Mfr.: J.S.T.)

- * Tolerance ±1 [±0.04]
- * Dimensions in mm, []=inches
- * Weight : 140g max
- * PCB material / thickness : FR-4 / 1.6mm
- * Mounting plate : Iron (surface finishing : nickel plating) / t=1.0mm
- * Terminal block screw tightening torque M3 : 0.8N · m max
- * CN4 has been installed jumper as factory setting (Except option R).
When remote ON/OFF is used , please remove the installed jumper.

External view (Option type)

Connector type (-J)

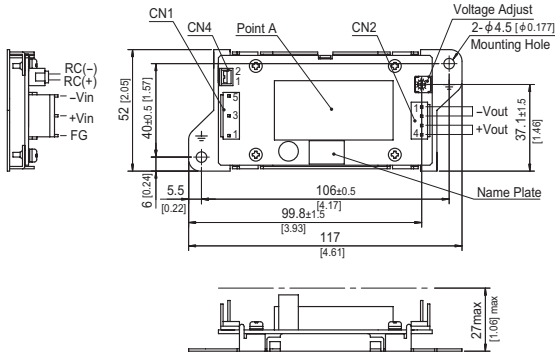

Case cover type (-N1)

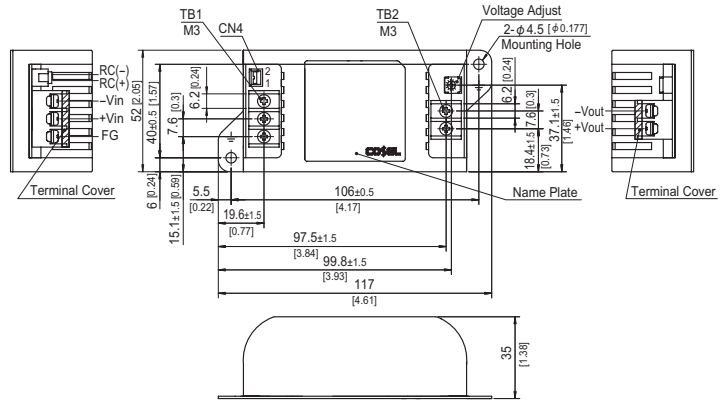

DIN rail installation type (-N2)

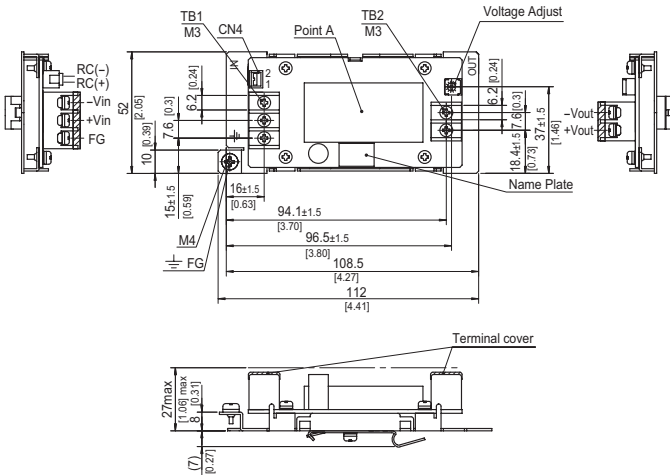

External voltage variable volume type (-V)

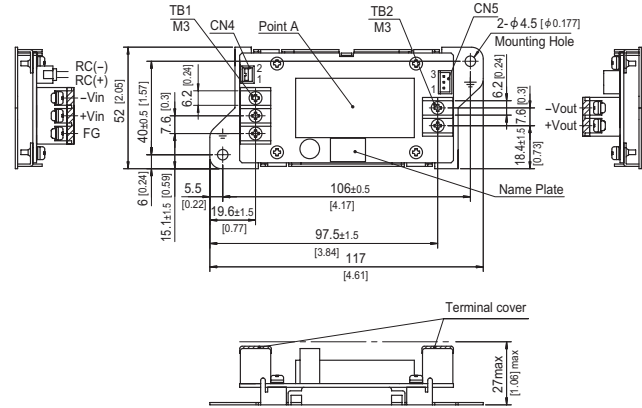

	I/O Connector		Mating Connector	Terminal
Connector Type Input	CN1	B3P5-VH	VHR-5N	Chain : SVH-21T-P1.1 Loose : BVH-21T-P1.1
Connector Type Output	CN2	B4P-VH	VHR-4N	Chain : SVH-21T-P1.1 Loose : BVH-21T-P1.1
Remote ON/OFF	CN4	B2B-XH	XHP-2	Chain : SXH-001T-P0.6 Loose : BXH-001T-P0.6
External voltage variable volume type	CN5	B3B-XH	XHP-3	Chain : SXH-001T-P0.6 Loose : BXH-001T-P0.6

(Mfr.:J.S.T.)

- * Tolerance ±1 [±0.04]
- * Dimensions in mm, []=inches
- * Weight : Standard & Connector type 140g max
Case cover & DIN rail installation type 160g max
- * PCB material / thickness : FR-4 / 1.6mm
- * Mounting plate : Iron (surface finishing : nickel plating) / t=1.0mm
- * Case : PBT
- * Terminal block screw tightening torque M3 : 0.8N · m max
- * CN4 has been installed jumper as factory setting (Except option R).
- * When remote ON/OFF is used, please remove the installed jumper.
- * Connector Type : Keep drawing current per pin below 5A for CN2.

STMGF30

STMGF W 30 24 05 -□

① ② ③ ④ ⑤ ⑥

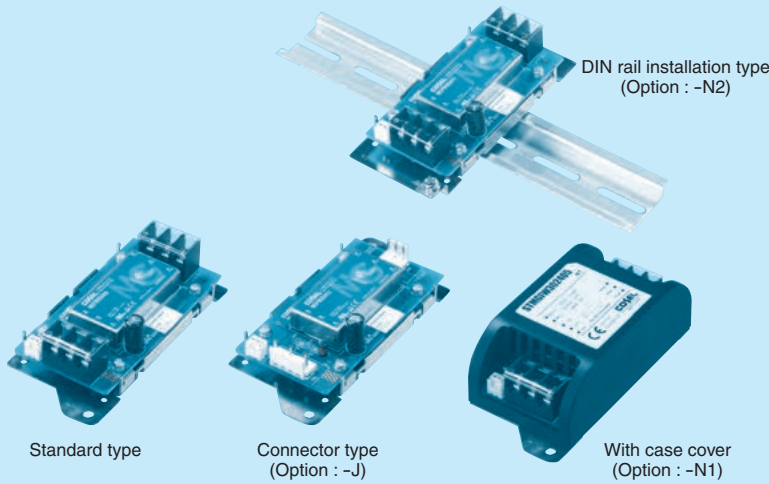

- ① Series name
- ② Dual output
- ③ Output wattage
- ④ Input voltage
- ⑤ Output voltage
- ⑥ Optional
 - G: Capacitor between Input and Output is removed.
 - R: with Remote ON/OFF (Positive logic control)
 - J: Input/Output Connector
 - N1: With case cover
 - N2: With DIN rail installation type
 - N3: With cover(plastic) and DIN rail installation type

*When the option is set specifications may vary.

*Please remove short piece on CN4 to enable remote ON/OFF function.

MODEL	STMGF302405	STMGF302412	STMGF302415	STMGF304805	STMGF304812	STMGF304815
MAX OUTPUT WATTAGE[W]	20	30	30	20	30	30
DC OUTPUT	VOLTAGE[V] *1	±5 or +10	±12 or +24	±15 or +30	±5 or +10	±12 or +24
	CURRENT[A]	2	1.25	1	2	1.25

SPECIFICATIONS

	MODEL	STMGF302405	STMGF302412	STMGF302415	STMGF304805	STMGF304812	STMGF304815	
INPUT	VOLTAGE[V]	DC9 - 36			DC18 - 76			
	CURRENT[A] *2	0.98typ	1.42typ	1.44typ	0.49typ	0.71typ	0.72typ	
	EFFICIENCY[%] *2	85typ	88typ	87typ	85typ	88typ	87typ	
OUTPUT	VOLTAGE[V]	±5(+10)	±12(+24)	±15(+30)	±5(+10)	±12(+24)	±15(+30)	
	CURRENT[A]	2	1.25	1	2	1.25	1	
	LINE REGULATION[mV]	40max	60max	75max	40max	60max	75max	
	LOAD REGULATION[mV]	*3	500max *5	600max	750max	500max *5	600max	750max
		*4	250max	480max	600max	250max	480max	600max
	RIPPLE[mVp-p] *6	0 to +60°C	100max	100max	100max	100max	100max	100max
		-20 to +60°C	120max	120max	120max	120max	120max	120max
	RIPPLE NOISE[mVp-p] *6	0 to +60°C	150max	150max	150max	150max	150max	150max
		-20 to +60°C	200max	200max	200max	200max	200max	200max
	TEMPERATURE REGULATION[mV]	0 to +60°C	50max	150max	180max	50max	150max	180max
		-20 to +60°C	80max	240max	290max	80max	240max	290max
DRIFT[mV] *7	50max	50max	60max	50max	50max	60max		
START-UP TIME[ms]	30max (Minimum input, Io=100%)							
OUTPUT VOLTAGE SETTING[V]*8	4.93 - 5.24	11.76 - 12.50	14.60 - 15.51	4.93 - 5.24	11.76 - 12.50	14.60 - 15.51		
PROTECTION CIRCUIT AND OTHERS	OVERCURRENT PROTECTION	Works over 105% of rating and recovers automatically						
	OVERVOLTAGE PROTECTION[V]	Works over 120 to 160% of rating (Total of +V and -V)						
	REMOTE ON/OFF	Provided (Negative logic L:ON, H:OFF)						
ISOLATION	INPUT · RC-OUTPUT	DC1,500V 1minute, Cutoff current = 10mA, DC500V 1,000MΩ min (20±15°C)						
	INPUT · RC-FG	DC1,000V 1minute, Cutoff current = 10mA, DC500V 1,000MΩ min (20±15°C)						
	OUTPUT-FG	DC1,000V 1minute, Cutoff current = 10mA, DC500V 1,000MΩ min (20±15°C)						
ENVIRONMENT	OPERATING TEMP., HUMID. AND ALTITUDE	-20 to +70°C, 20 to 95%RH (Non condensing) (Refer to "Derating"), 3,000m (10,000feet) max						
	STORAGE TEMP., HUMID. AND ALTITUDE	-20 to +75°C, 20 to 95%RH (Non condensing), 9,000m (30,000feet) max						
	VIBRATION	10 - 55Hz, 19.6m/s ² (2G), 3minutes period, 60minutes each along X, Y and Z axis						
	IMPACT	196.1m/s ² (20G), 11ms, once each along X, Y and Z axis						
SAFETY	AGENCY APPROVALS	UL60950-1, C-UL, EN62368-1 Complies						
OTHERS	CASE SIZE/WEIGHT	52 X 27 X 117mm [2.05x1.06x4.61 inches] (W X H X D) / 140g max (When the option is set, refer to the page STMG-13)						
	COOLING METHOD	Convection/Forced air						

*1 Single output +10V, +24V, +30V with no use of COM.

*2 Rated input 12V, 24V or 48V DC Io=100%

*3 Symmetrical loading from 5% to 100%.

*4 Symmetrical loading from 20% to 100%.

*5 Refer to the instruction manual 7.

*6 Measured by 100MHz oscilloscope or Ripple-Noise meter (Equivalent to KIKUSUI-GIKEN : RM103).

*7 Drift is the DC output accuracy for eight hours period after a half-hour warm-up at 25°C.

*8 Rated input voltage (DC24V, DC48V), rated output wattage, ambient temperature at 25°C.

* Parallel operation with other model is not possible.

External view

Standard type

* External view of option G, R are the same as standard model.

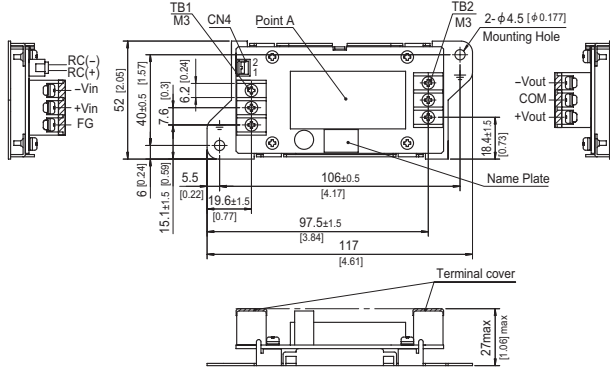

Connector type (-J)

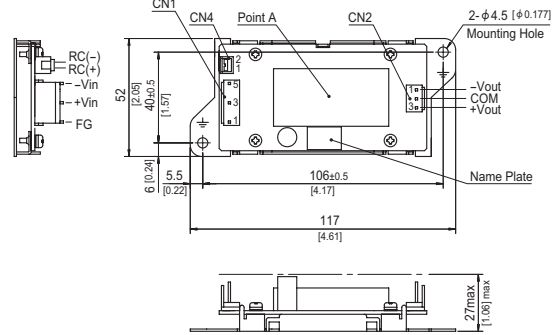

Case cover type (-N1)

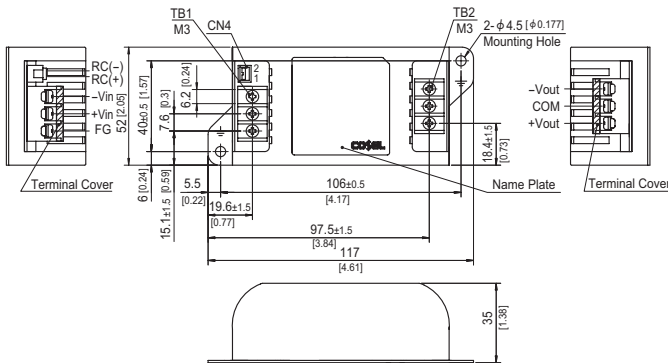

DIN rail installation type (-N2)

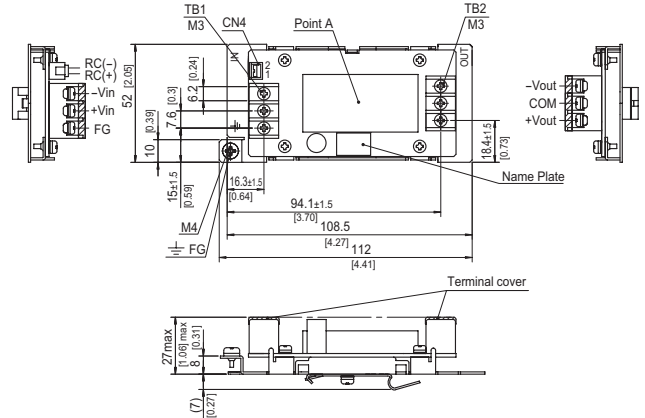

	I/O Connector		Mating Connector	Terminal
Connector Type Input	CN1	B3P5-VH	VHR-5N	Chain : SVH-21T-P1.1 Loose : BVH-21T-P1.1
Connector Type Output	CN2	B3P-VH	VHR-3N	Chain : SVH-21T-P1.1 Loose : BVH-21T-P1.1
Remote ON/OFF	CN4	B2B-XH	XHP-2	Chain : SXH-001T-P0.6 Loose : BXH-001T-P0.6

(Mfr.:J.S.T.)

- * Tolerance ± 1 [± 0.04]
- * Dimensions in mm, []=inches
- * Weight : Standard & Connector type 140g max
Case cover & DIN rail installation type 160g max
- * PCB material / thickness : FR-4 / 1.6mm
- * Mounting plate : Iron (surface finishing : nickel plating) / t=1.0mm
- * Case : PBT
- * Terminal block screw tightening torque M3 : 0.8N · m max
- * CN4 has been installed jumper as factory setting (Except option R).
When remote ON/OFF is used, please remove the installed jumper.
- * Connector Type : Keep drawing current per pin below 5A for CN2.

STMGFS80

STMGF S 30 24 05 -□

① ② ③ ④ ⑤ ⑥

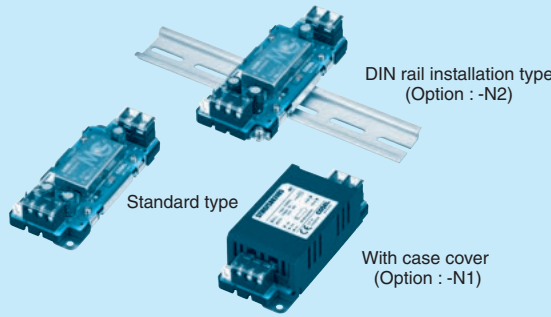

- ① Series name
- ② Single output
- ③ Output wattage
- ④ Input voltage
- ⑤ Output voltage
- ⑥ Optional
- R : with Remote ON/OFF (Positive logic control)
- N1 : With case cover
- N2 : With DIN rail installation type
- N3 : With cover (plastic) and DIN rail installation type

*When the option is set specifications may vary.

*Please remove short piece on CN3 to enable remote ON/OFF function.

MODEL	STMGFS80243R3	STMGFS802405	STMGFS802412	STMGFS802415
MAX OUTPUT WATTAGE[W]	59.4	80	80.4	81
DC OUTPUT	VOLTAGE[V]	3.3	5	12
	CURRENT[A]	18	16	6.7

SPECIFICATIONS

	MODEL	STMGFS80243R3	STMGFS802405	STMGFS802412	STMGFS802415	
INPUT	VOLTAGE[V]	DC9 - 36				
	CURRENT[A]	*1 2.75typ	3.70typ	3.64typ	3.67typ	
	EFFICIENCY[%]	*1 90typ	90typ	92typ	92typ	
OUTPUT	VOLTAGE[V]	3.3	5	12	15	
	CURRENT[A]	18	16	6.7	5.4	
	LINE REGULATION[mV]	13.2max	20max	48max	60max	
	LOAD REGULATION[mV]	60max	60max	100max	120max	
	RIPPLE[mVp-p]	0 to +60°C	75max	75max	100max	100max
		-20 to +60°C	100max	100max	120max	120max
		Io=0 to 10%	200max	200max	240max	240max
	RIPPLE NOISE[mVp-p]	0 to +60°C	75max	75max	100max	100max
		-20 to +60°C	150max	150max	150max	150max
		Io=0 to 10%	250max	250max	270max	270max
	TEMPERATURE REGULATION[mV]	0 to +60°C	50max	50max	150max	180max
	-20 to +60°C	80max	80max	240max	290max	
DRIFT[mV]	*3 20max	20max	48max	60max		
START-UP TIME[ms]	30max (Minimum input, Rated load)					
OUTPUT VOLTAGE ADJUSTMENT RANGE	2.97 - 3.63	4.50 - 5.50	10.80 - 13.20	13.50 - 16.50		
OUTPUT VOLTAGE SETTING[V]*4	3.29 - 3.41	4.97 - 5.14	11.85 - 12.25	14.83 - 15.33		
PROTECTION CIRCUIT AND OTHERS	OVERCURRENT PROTECTION	Works over 105% of rating and recovers automatically				
	OVERVOLTAGE PROTECTION	Works over 115 to 140% of rating				
	REMOTE ON/OFF	Provided (Negative logic L:ON, H:OFF)				

MODEL	STMGFS80483R3	STMGFS804805	STMGFS804812	STMGFS804815
MAX OUTPUT WATTAGE[W]	59.4	80	80.4	81
DC OUTPUT	VOLTAGE[V]	3.3	5	12
	CURRENT[A]	18	16	6.7

SPECIFICATIONS

	MODEL	STMGFS80483R3	STMGFS804805	STMGFS804812	STMGFS804815	
INPUT	VOLTAGE[V]	DC18 - 76				
	CURRENT[A]	*1 1.38typ	1.85typ	1.82typ	1.83typ	
	EFFICIENCY[%]	*1 90typ	90typ	92typ	92typ	
OUTPUT	VOLTAGE[V]	3.3	5	12	15	
	CURRENT[A]	18	16	6.7	5.4	
	LINE REGULATION[mV]	13.2max	20max	48max	60max	
	LOAD REGULATION[mV]	60max	60max	100max	120max	
	RIPPLE[mVp-p]	0 to +60°C	75max	75max	100max	100max
		-20 to +60°C	100max	100max	120max	120max
		Io=0 to 10%	200max	200max	240max	240max
	RIPPLE NOISE[mVp-p]	0 to +60°C	75max	75max	100max	100max
		-20 to +60°C	150max	150max	150max	150max
		Io=0 to 10%	250max	250max	270max	270max
	TEMPERATURE REGULATION[mV]	0 to +60°C	50max	50max	150max	180max
	-20 to +60°C	80max	80max	240max	290max	
DRIFT[mV]	*3 20max	20max	48max	60max		
START-UP TIME[ms]	30max (Minimum input, Rated load)					
OUTPUT VOLTAGE ADJUSTMENT RANGE	2.97 - 3.63	4.50 - 5.50	10.80 - 13.20	13.50 - 16.50		
OUTPUT VOLTAGE SETTING[V]*4	3.29 - 3.41	4.97 - 5.14	11.85 - 12.25	14.83 - 15.33		
PROTECTION CIRCUIT AND OTHERS	OVERCURRENT PROTECTION	Works over 105% of rating and recovers automatically				
	OVERVOLTAGE PROTECTION	Works over 115 to 140% of rating				
	REMOTE ON/OFF	Provided (Negative logic L:ON, H:OFF)				

GENERAL SPECIFICATIONS

ISOLATION	INPUT · RC-OUTPUT	DC1,500V 1minute, Cutoff current = 10mA, DC500V 1,000MΩ min (20±15°C)
	INPUT · RC-FG	DC1,000V 1minute, Cutoff current = 10mA, DC500V 1,000MΩ min (20±15°C)
	OUTPUT-FG	DC1,000V 1minute, Cutoff current = 10mA, DC500V 1,000MΩ min (20±15°C)
ENVIRONMENT	OPERATING TEMP., HUMID. AND ALTITUDE	-20 to +70°C, 20 to 95%RH (Non condensing) (Refer to "Derating"), 3,000m (10,000feet) max
	STORAGE TEMP., HUMID. AND ALTITUDE	-20 to +75°C, 20 to 95%RH (Non condensing), 9,000m (30,000feet) max
	VIBRATION	10 - 55Hz, 19.6m/s ² (2G), 3minutes period, 60minutes each along X, Y and Z axis
	IMPACT	196.1m/s ² (20G), 11ms, once each along X, Y and Z axis
SAFETY	AGENCY APPROVALS	UL62368-1, C-UL(CSA62368-1), EN62368-1 Complies
OTHERS	CASE SIZE/WEIGHT	52×29×117mm [2.05×1.14×4.61 inches] (W×H×D) / 170g max
	COOLING METHOD	Convection/Forced air

- *1 Rated input 12V, 24V or 48V DC I_o=100%
- *2 Measured by 100MHz oscilloscope or Ripple-Noise meter (Equivalent to KIKUSUI-GIKEN : RM103).
- *3 Drift is the DC output accuracy for eight hours period after a half-hour warm-up at 25°C.
- *4 Rated input voltage (DC24V, DC48V), rated output wattage, ambient temperature at 25°C.
- * Parallel operation with other model is not possible.

External view

Standard type

* External view of option R is the same as standard model.
External view of other type options, please refer to the page STMG-16.

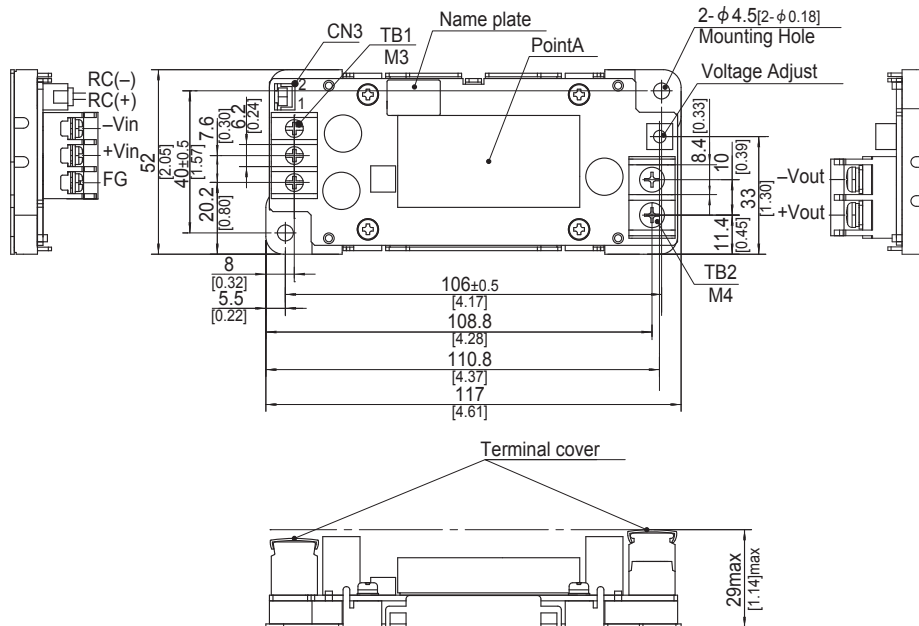

	I/O Connector		Mating Connector	Terminal
Remote ON/OFF	CN3	B2B-XH	XHP-2	Chain : SXH-001T-P0.6 Loose : BXH-001T-P0.6

(Mfr.: J.S.T.)

- * Tolerance ±1 [±0.04]
- * Dimensions in mm, []=inches
- * Weight : 170g max
- * PCB material / thickness : FR-4 / 1.6mm
- * Mounting plate : Iron (surface finishing : nickel plating) / t=1.0mm
- * Terminal block screw tightening torque M3 : 0.8N · m max
M4 : 1.6N · m max
- * CN3 has been installed jumper as factory setting (Except option R).
When remote ON/OFF is used , please remove the installed jumper.

External view (Option type)

Case cover type (-N1)

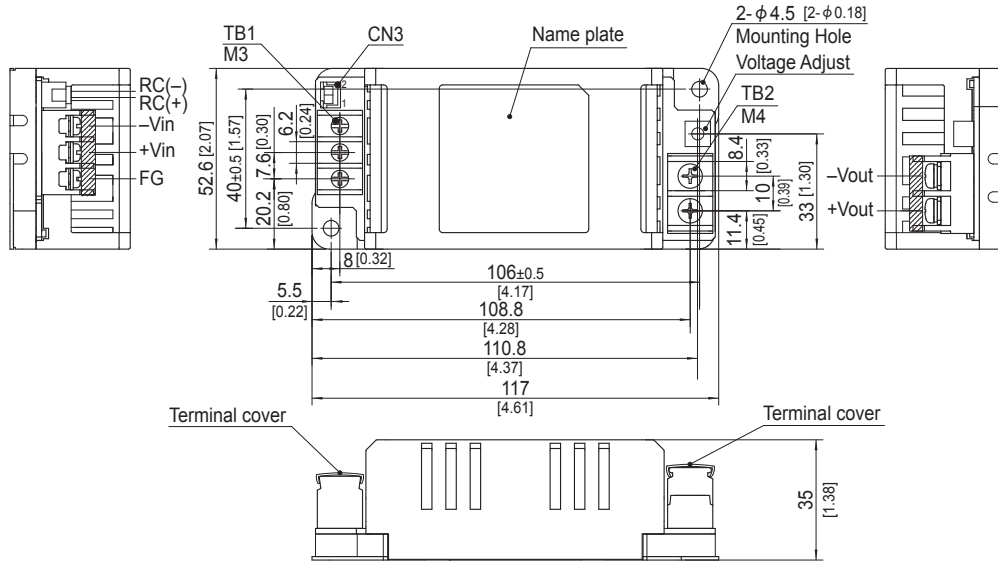

DIN rail installation type (-N2)

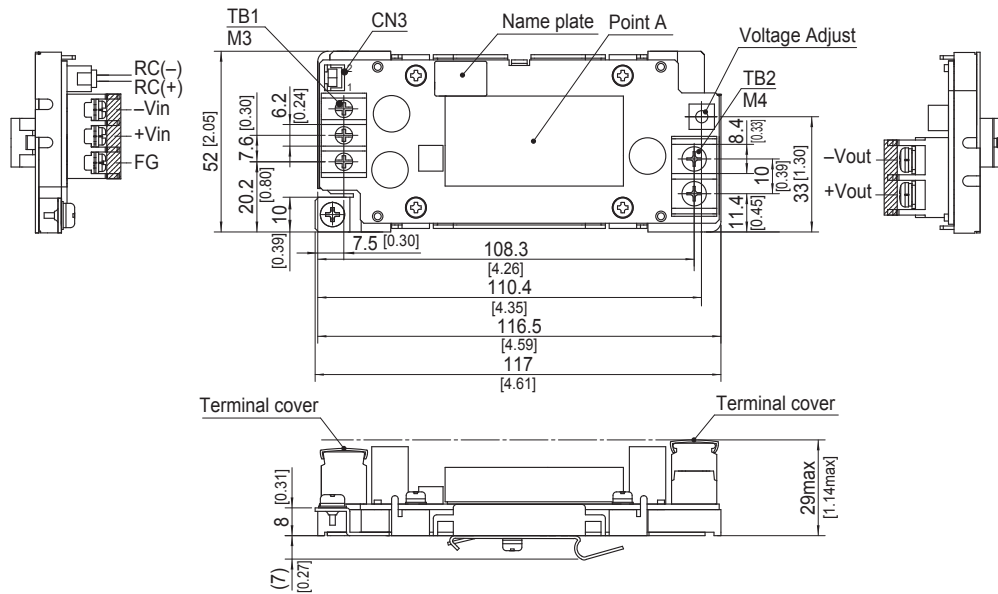

	I/O Connector		Mating Connector	Terminal
	Remote ON/OFF	CN3	B2B-XH	XHP-2

(Mfr.:J.S.T.)

- * Tolerance ± 1 [± 0.04]
- * Dimensions in mm, []=inches
- * Weight : Case cover type 210g max
DIN rail installation type 200g max
- * PCB Material / thickness FR-4 / $t=1.6$ mm
- * Mounting plate : Iron (surface finishing: nickel plating) / $t=1.0$ mm
- * Case : PBT
- * Terminal block screw tightening torque
M3 : 0.8N · m max
M4 : 1.6N · m max
- * CN3 has been installed jumper as factory setting (Except option R)
When remote ON/OFF is used, please remove the installed jumper.

Assembling and Installation Method

Installation

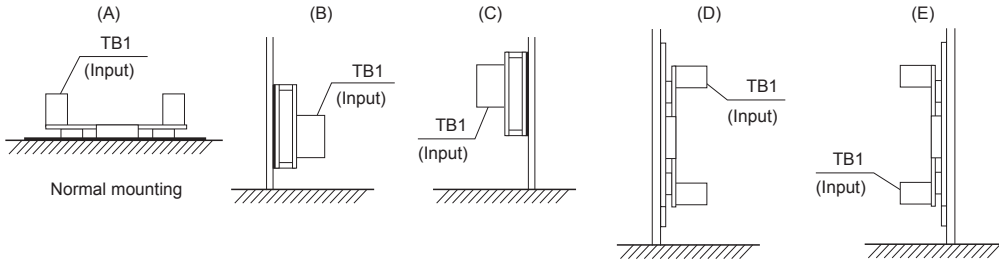

- Derating curve varies depending on the mounting direction. Refer to "Derating"
- Please note that a power supply and chassis will become hot depending on mounting direction or operating condition.

■ In case of metal chassis, keep the distance between d1 for to insulate between lead of component and metal chassis. If it is less than d1, insert the insulation sheet between power supply and metal chassis.

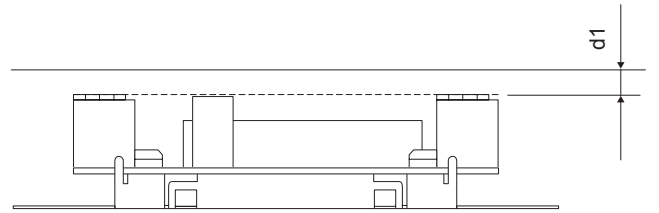

d1=4mm min.

Derating

● STMGFS80 Derating curve for input voltage

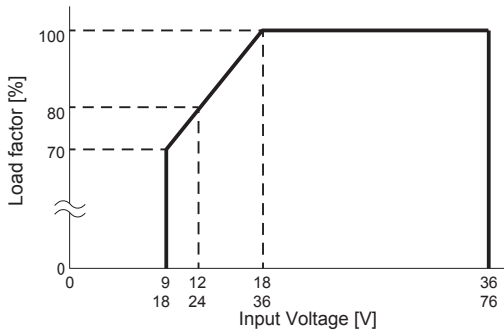

● STMGFS15/STMGFW15 Ambient temperature derating curve

■ Specifications for ripple and ripple noise change in the shaded area.

■ In the case of Convection Cooling

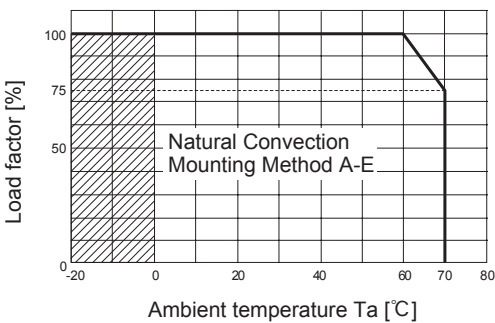

(1) Standard type (No Case cover type)

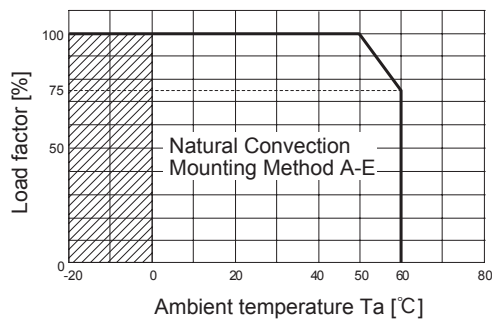

(2) Case cover type

Derating

■ In the case of Forced Air Cooling

In case of forced air cooling, please have sufficient ventilation to keep the temperature of point A in Instruction Manual5 at 105°C or below. Please also make sure that the ambient temperature does not exceed the range shown in below.

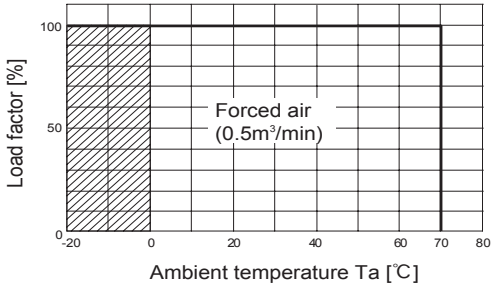

(1) Standard type (No Case cover type)

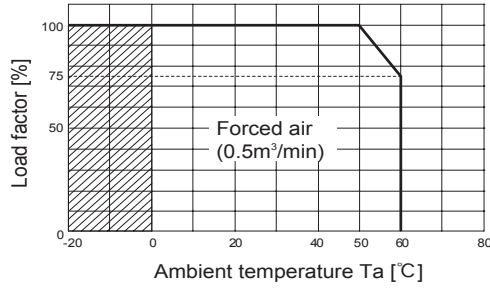

(2) Case cover type

● STMGFS30/STMGFW30 Ambient temperature derating curve

■ Specifications for ripple and ripple noise change in the shaded area.

■ In the case of Convection Cooling

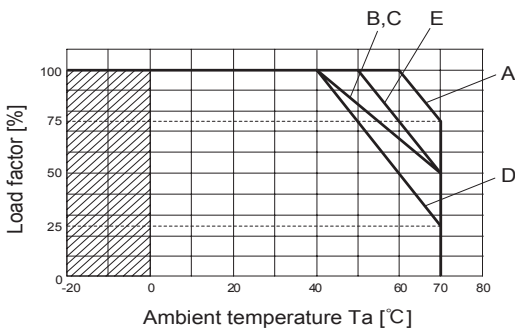

(1) Standard type (No Case cover type)

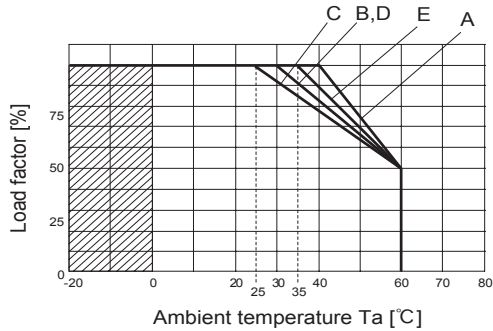

(2) Case cover type

■ In the case of Forced Air Cooling

In case of forced air cooling, please have sufficient ventilation to keep the temperature of point A in Instruction Manual5 at 105°C or below. Please also make sure that the ambient temperature does not exceed the range shown in below.

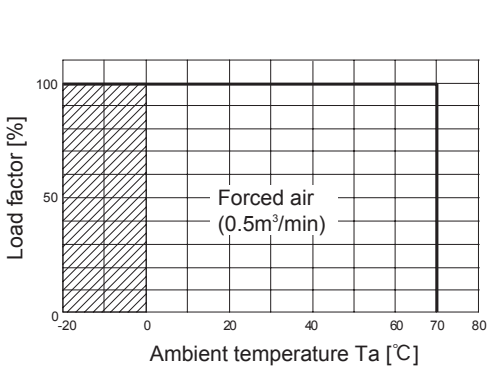

(1) Standard type (No Case cover type)

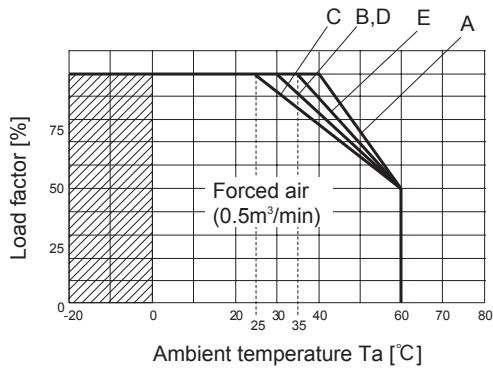

(2) Case cover type

Derating

● STMGFS80 Ambient temperature derating curve (Reference value)

■ Specifications for ripple and ripple noise changes in the shaded area.

■ In the case of Convection Cooling

When using the product, make sure that the temperature at point A is below the temperature shown in the instruction manual 5. Please also make sure that the ambient temperature does not exceed 70°C.

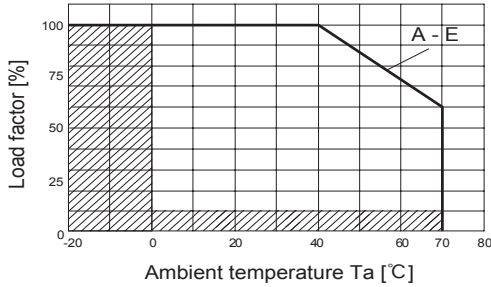

(1) Standard type (No Case cover type)

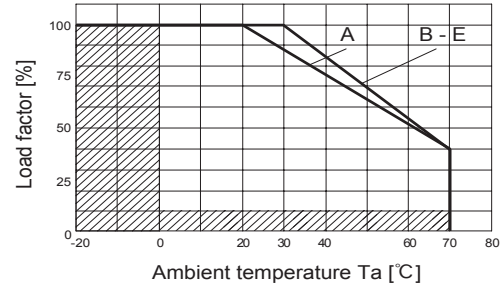

(2) Case cover type

Instruction Manual

◆ It is necessary to read the “Instruction Manual” and “Before using our product” before you use our product.

- Instruction Manual <https://www.cosel.co.jp/redirect/catalog/en/STMGFS/>
- Instruction Manual <https://www.cosel.co.jp/redirect/catalog/en/STMGFW/>
- Before using our product <https://en.cosel.co.jp/technical/caution/index.html>



Basic Characteristics Data

Model	Circuit method	Switching frequency [kHz] (reference)	Input current [A]	Inrush current protection	PCB/Pattern*4			Series/Parallel operation availability	
					Material	Single sided	Double sided	Series operation	Parallel operation
STMGF15	Flyback converter	445-495	*1	-	glass fabric base,epoxy resin		Yes	Yes	*2
STMGF30	Forward converter	380-460	*1	-	glass fabric base,epoxy resin		Yes	Yes	*2
STMGFS80	Flyback converter	100-1500*3	*1	-	glass fabric base,epoxy resin		Yes	Yes	*2

*1 Refer to Specification.
 *2 Refer to Instruction Manual.
 *3 The value changes depending on input and load.
 *4 MG series with the power supply unit, please refer to the basic characteristics of the MG series data.



Low Profile



Safety Approvals



OCP



Remote ON/OFF

BRNS-series



BRNS

Feature

- Small size and high efficiency non-isolated DC-DC converter.
- Wide input voltage 3.0V to 14.4V.
- Adjustment of the gain control depending on external capacitor is unnecessary.
- Built-in remote ON/OFF, Power good, Frequency synchronization.
- Built-in overcurrent and thermal protection (auto recovery type) functions.

CE marking

- Low Voltage Directive
- RoHS Directive

UKCA marking

- Electrical Equipment Safety Regulations
- RoHS Regulations

Safety agency approvals

- UL60950-1, C-UL, EN62368-1

5-year warranty

BRNS

BRN S 20 -□

① ② ③ ④



RoHS



- ① Series name
- ② Single output
- ③ Output current
6: 6A
12: 12A
20: 20A
- ④ Optional
R: Positive logic remote on/off
I: No clock output for frequency synchronization
Y1: Suitable control for external capacitor over 470 μF

MODEL	BRNS6	BRNS12	BRNS20
MAX OUTPUT CURRENT[A]	6.0	12.0	20.0
DC OUTPUT	0.6 - 5.5		

SPECIFICATIONS

	MODEL	BRNS6	BRNS12	BRNS20
INPUT	VOLTAGE[V]	DC3.0 - 14.4		
	CURRENT[A]	*1 0.70 typ	1.40 typ	2.30 typ
	EFFICIENCY[%]	*1 86 typ	86 typ	87 typ
OUTPUT	VOLTAGE[V]	*2 0.6 - 5.5	0.6 - 5.5	0.6 - 5.5
	CURRENT[A]	6	12	20
	LINE REGULATION1[mV] Vo ≤ 1.8V	10		
	LINE REGULATION2[%Vo] Vo > 1.8V	0.5		
	LOAD REGULATION1[mV] Vo ≤ 1.8V	10		
	LOAD REGULATION2[%Vo] Vo > 1.8V	0.5		
	OUTPUT VOLTAGE SETTING [%Vo]	±1.0		
	RIPPLE[mVp-p]	*3 25		
	RIPPLE NOISE[mVp-p]	*3 50		
	DRIFT[%Vo]	*4 ±0.5		
	START-UP TIME[ms]	4.5 typ		
OUTPUT VOLTAGE ADJUSTMENT RANGE [V]		Adjustable by external resistor		
		0.6 - 5.5		
OUTPUT VOLTAGE REGULATION [%Vo]*5		±3.0		
PROTECTION CIRCUIT AND OTHERS	OVERCURRENT PROTECTION	Works over 105% of rating (auto recovery type)		
	REMOTE SENSING	Available (+S only)		Available
	REMOTE ON/OFF	Available Negative logic L:ON, H:OFF		
ISOLATION	INPUT-OUTPUT	non-isolated		
ENVIRONMENT	OPERATING TEMP., HUMID. AND ALTITUDE	-40 to +85°C, 20-95%RH (Non condensing) (Refer to "Derating") 3,000m (10,000feet) max		
	STORAGE TEMP., HUMID. AND ALTITUDE	-40 to +100°C, 20-95%RH (Non condensing), 9,000m (30,000feet) max		
	VIBRATION	10-55Hz, 49.0m/s ² (5G), 3minutes period, 60minutes each along X, Y and Z axis		
	IMPACT	196.1m/s ² (20G), 11ms, once each along X, Y and Z axis		
SAFETY	AGENCY APPROVALS	UL60950-1, C-UL(CSA60950-1), EN62368-1		
OTHERS	CASE SIZE/WEIGHT	12.2×7.2×12.2mm [0.48×0.28×0.48 inches] (W×H×D) / 4g max	20.3×8.5×11.4mm [0.80×0.35×0.45 inches] (W×H×D) / 6g max	
	COOLING METHOD	Convection / Forced air		

*1 At rated input (DC12V) and rated output (1.2V) Ta=25°C.
 *2 Output voltage is adjusted to the minimum when TRM is opened.
 *3 Ripple and ripple noise is measured by using measuring board with ceramic capacitor at 25mm from output pin.
 At rated input (DC12V) and rated output (1.2V).
 *4 Drift is the change in DC output for an eight hour period after a half - hour warm - up at 25°C, with the input voltage held.
 *5 Output voltage setting is added line regulation and load regulation and temperature regulation used resistance of the 0.5% tolerance.

External view

1. BRNS6 / 12

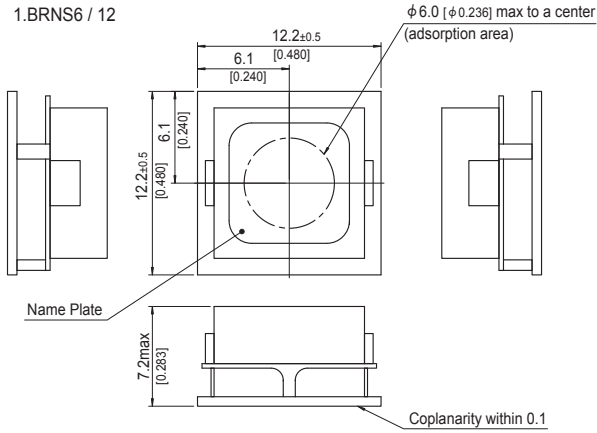

2. BRNS20

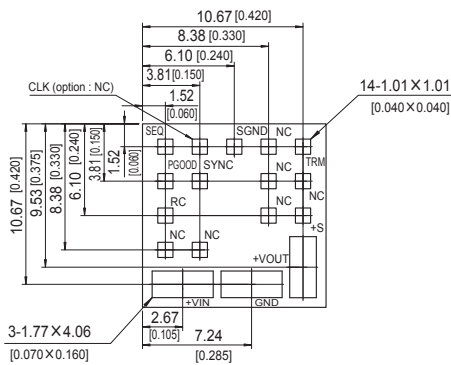
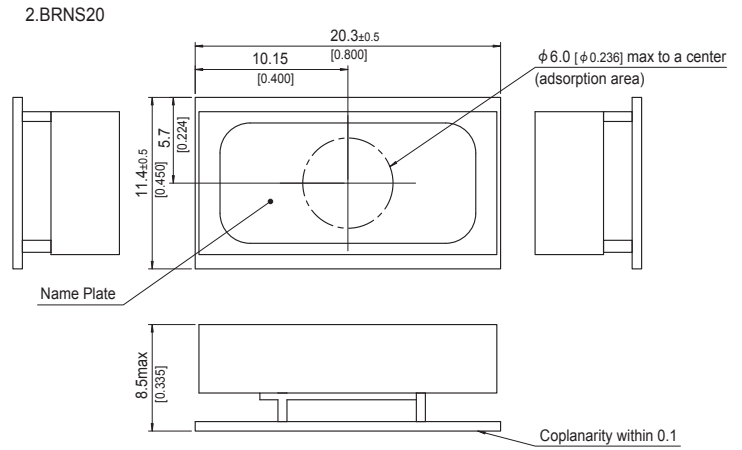

- ※ Tolerance : ± 0.3
- ※ Dimensions in mm, [] =inches
- ※ Weight : 4.0g max
- ※ Terminal material : PCB pattern
- ※ Plating treatment of terminal : Gold flashing

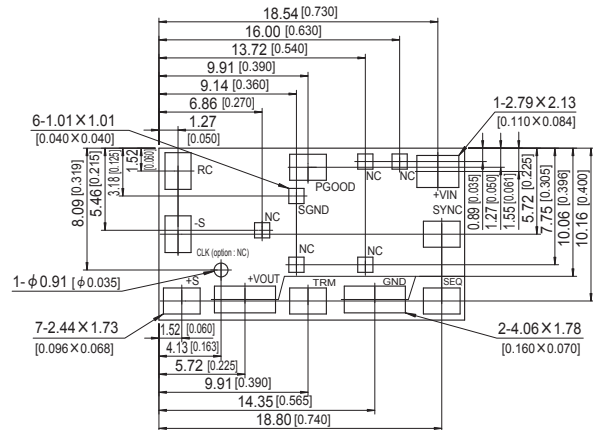

- ※ Tolerance : ± 0.3
- ※ Dimensions in mm, [] =inches
- ※ Weight : 6.0g max
- ※ Terminal material : PCB pattern
- ※ Plating treatment of terminal : Gold flashing

Recommended size for processing PCB

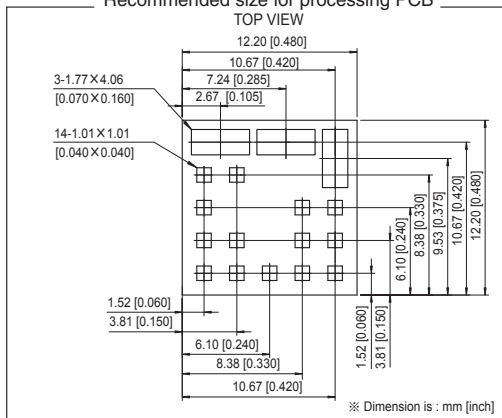

Recommended size for processing PCB

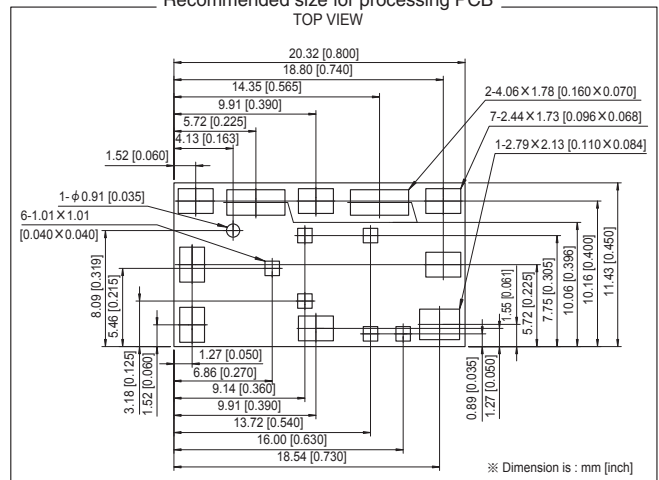

Pin Configuration

BRNS6/12

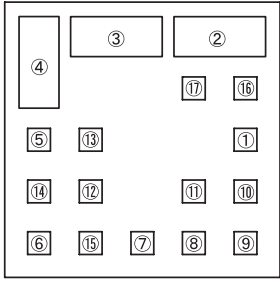

*BOTTOM VIEW

BRNS20

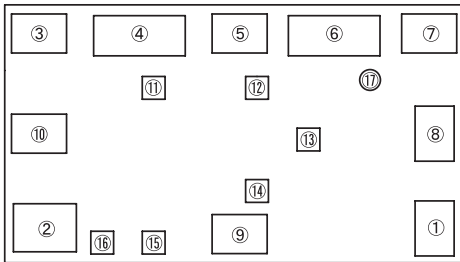

*BOTTOM VIEW

Pin No.		Pin Connection	Function
BRNS 6/12	BRNS 20		
①		RC	Remote ON/OFF
②		+VIN	+DC input
③	④	GND	GND(-DC input, -DC output)
④	⑥	+VOUT	+DC output
⑤	⑦	+S	+Remote sensing
⑥	⑤	TRM	Adjustment of output voltage
⑦	⑭	SGND	Signal GND
⑧	⑰	CLK(NC)	Clock output
⑨	③	SEQ	Control of Start up time and turn
⑩	⑨	PGOOD	Power good
⑪	⑩	SYNC	Input for frequency synchronization
⑫	⑧	-S	NC : BRNS6/12 -Remote sensing : BRNS20
⑬	⑪	NC	NC
⑭	⑬	NC	NC
⑮	⑫	NC	NC
⑯	⑯	NC	NC
⑰	⑮	NC	NC

Implementation · Mounting Method

Mounting method

■ The unit can be mounted in any direction. When two or more power supplies are used side by side, position them with proper intervals to allow enough air ventilation. The temperature around each power supply should not exceed the temperature range shown in "Derating".

Automatic Mounting

■ To mount BRNS series automatically, use the coil area near the center of the PCB as an adsorption point. Please see the External View for details of the adsorption point.

Soldering

■ Right figure shows condition for reflow of BRNS series. Please make sure that the temperature of board's pattern near by +VOUT and GND terminal.

■ While soldering, having vibration or impact on the unit should be avoided, because of solder melting.

■ Please do not do the implementation except the reflow.

■ Because some parts drops, please do not do reflow of the back side.

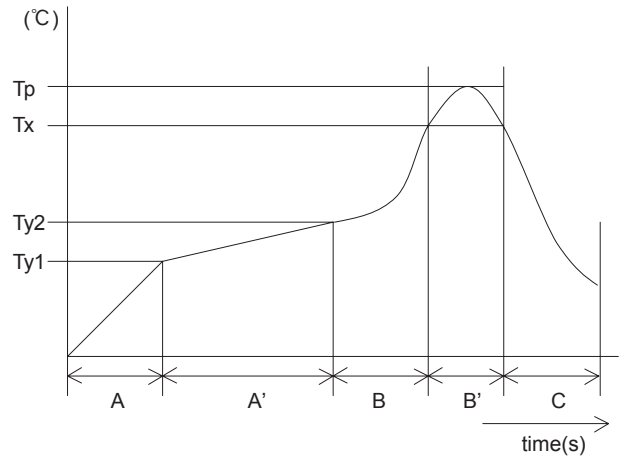

A	1.0 - 5.0°C/ s
A'	Ty1 : 160 ± 10°C Ty2 : 180 ± 10°C Ty1 - Ty2 : 120s max
B	1.0 - 5.0°C/ s
B'	Tp : Max245°C 10s max Tx : 220°C or more : 70s max
C	1.0 - 5.0°C/ s

Derating

- Make sure the temperatures measurement locations shown from Instruction Manual 8 are on or under the derating curve in right figure. Ambient temperature must be kept at 85°C or under.

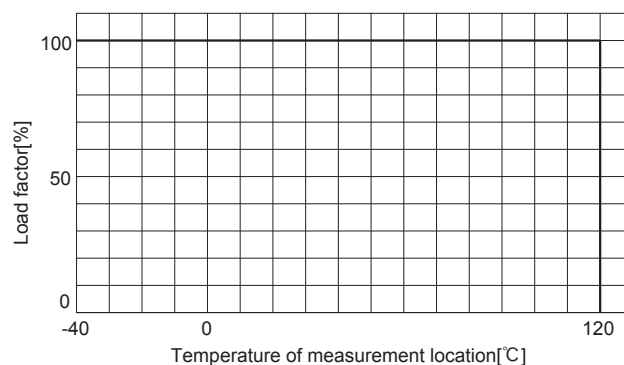

Instruction Manual

- It is necessary to read the “Instruction Manual” and “Before using our product” before you use our product.

Instruction Manual <https://www.cosel.co.jp/redirect/catalog/en/BRNS/>
 Before using our product <https://en.cosel.co.jp/technical/caution/index.html>

BRNS



NOTICE



BRNS

Basic Characteristics Data

Model	Circuit method	Switching frequency [kHz] (reference)	Input current [A]	Inrush current protection	PCB/Pattern			Series/Parallel operation	
					Material	Single sided	Double sided	Series operation	Parallel operation
BRNS6	Buck Converter	600	* 1	-	glass fabric base,epoxy resin	-	Multilayer	-	-
BRNS12	Buck Converter	600	* 1	-	glass fabric base,epoxy resin	-	Multilayer	-	-
BRNS20	Buck Converter	600	* 1	-	glass fabric base,epoxy resin	-	Multilayer	-	-

*1 Refer to Specification.



Low Profile



Safety Approvals



OCP



Remote ON/OFF

BRFS/BRDS-series

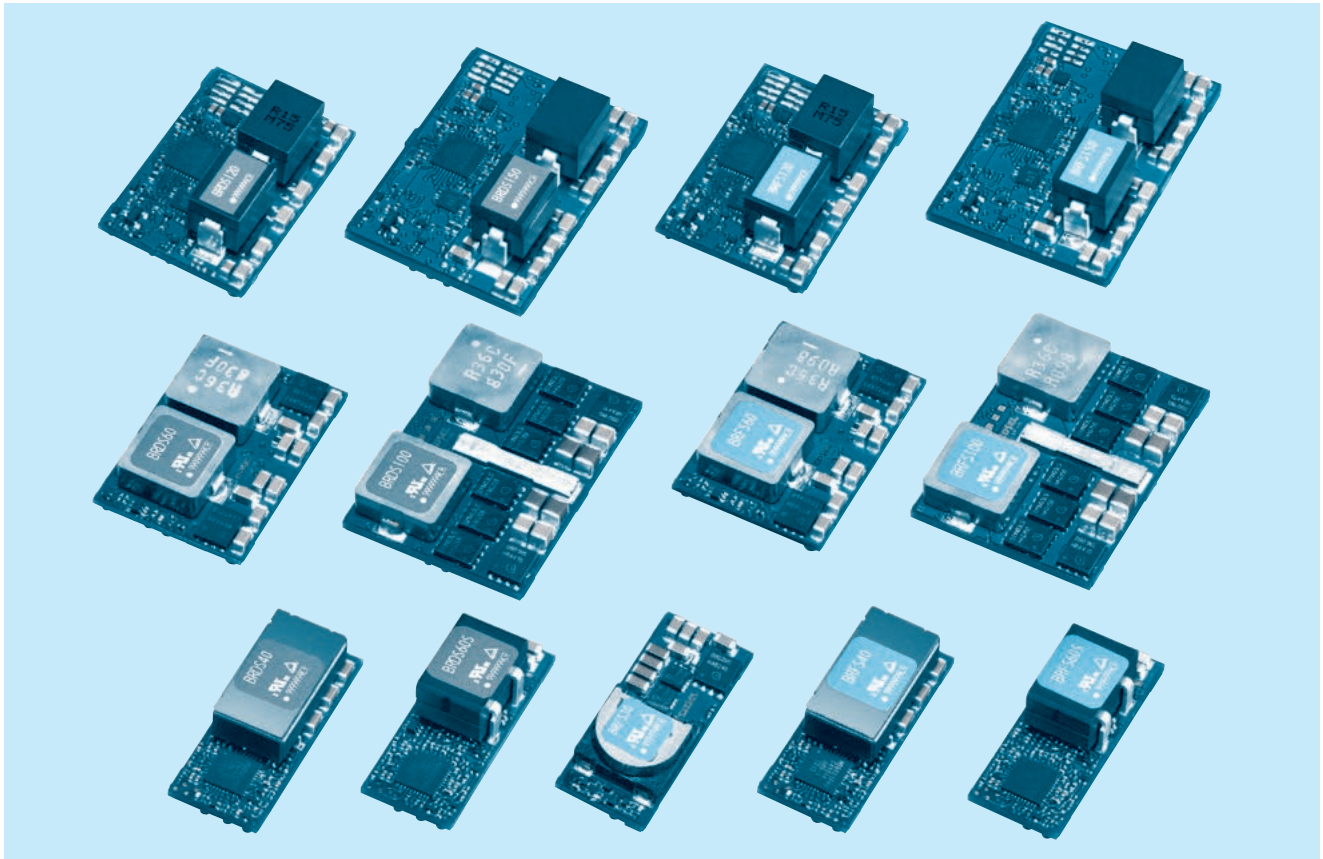

BRFS/BRDS

Feature

- Small size and high efficiency non-isolated DC-DC converter.
- Wide input voltage 4.5V to 14.0V.
- Fast transient response by Robust control.
- Built-in remote ON/OFF, Power good, Start-up sequence.
- Built-in overcurrent and thermal protection (auto recovery type) functions.
- PMBus interface for programming, margining, and telemetry (BRDS-series).

CE marking

- Low Voltage Directive
- RoHS Directive

UKCA marking

- Electrical Equipment Safety Regulations
- RoHS Regulations

Safety agency approvals

- UL60950-1, C-UL, EN62368-1

5-year warranty

BRFS

BRF S 60 S -□

① ② ③ ④ ⑤

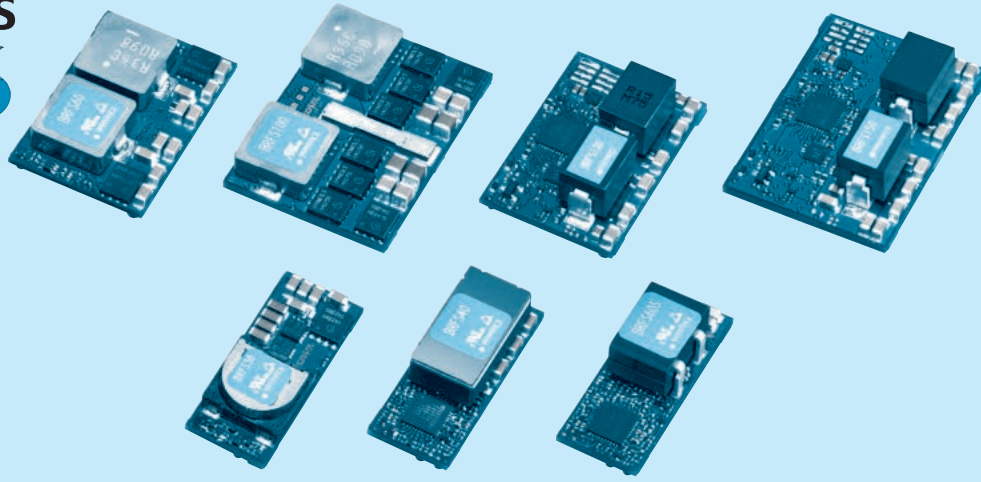

- ① Series name
- ② Single output
- ③ Output current
30:30A
40:40A
60:60A
100:100A
120:120A
150:150A
- ④ Type
Blank : Standard type
S : Small type (only 60A)
- ⑤ Optional
R : Positive logic remote on/off
I : POWERGOOD (only BRFS30/40/60S)
*Other models has POWERGOOD function normally.
P : Parallel operation (only BRFS40/60S)
Y1 : Fast transient response (only BRFS100)

MODEL	BRFS30	BRFS40	BRFS60	BRFS60S	BRFS100	BRFS120	BRFS150
MAX OUTPUT CURRENT[A]	30.0	40.0	60.0	60.0	100.0	120.0	150.0
DC OUTPUT	0.8 - 3.63V	0.6 - 2.0V	0.7 - 2.0V	0.6 - 2.0V	0.7 - 2.0V	0.6 - 1.8V	0.6 - 1.8V *7

SPECIFICATIONS

	MODEL	BRFS30	BRFS40	BRFS60	BRFS60S	BRFS100	BRFS120	BRFS150	
INPUT	VOLTAGE[V]	DC4.5 - 14.0							
	CURRENT[A]	*1 3.41 typ	4.52 typ	6.82 typ	6.71 typ	11.24 typ	13.50 typ	16.90 typ	
	EFFICIENCY[%]	*1 88.0 typ	88.5 typ	88.0 typ	89.5 typ	89.0 typ	89.0 typ	89.0 typ	
OUTPUT	VOLTAGE[V]	*2 0.8 - 3.63	0.6 - 2.0	0.7 - 2.0	0.6 - 2.0	0.7 - 2.0	0.6 - 1.8	0.6 - 1.8 *7	
	CURRENT[A]	30	40	60	60	100	120	150	
	LINE REGULATION[mV]	5							
	LOAD REGULATION[mV]	5							
	RIPPLE[mVp-p]	*3 25							
	RIPPLE NOISE[mVp-p]	*3 50							
	OUTPUT VOLTAGE SETTING [%Vo]	±1							
	DRIFT[mV]	*4 5							
	START-UP TIME[ms]	8.0 typ			12.0 typ *6	8.0 typ	12.0 typ *6		
	OUTPUT VOLTAGE ADJUSTMENT RANGE [V]	Adjustable by external resistor							
	0.8 - 3.63	0.6 - 2.0	0.7 - 2.0	0.6 - 2.0	0.7 - 2.0	0.6 - 1.8	0.6 - 1.8 *7		
	OUTPUT VOLTAGE TOTAL REGULATION [%Vo]*5 ±3								
PROTECTION CIRCUIT AND OTHERS	OVERCURRENT PROTECTION	Works over 105% of rating (auto recovery type)							
	REMOTE SENSING	Available (+S only)		Available	Available (+S only)	Available			
	REMOTE ON/OFF	Available Negative logic L:ON, H:OFF							
ISOLATION	INPUT-OUTPUT	non-isolated							
ENVIRONMENT	OPERATING TEMP., HUMID. AND ALTITUDE	-40 to +85°C, 20-95%RH (Non condensing) (Refer to "Derating") 3,000m (10,000feet) max							
	STORAGE TEMP., HUMID. AND ALTITUDE	-40 to +100°C, 20-95%RH (Non condensing), 9,000m (30,000feet) max							
	VIBRATION	10-55Hz, 49.0m/s ² (5G), 3minutes period, 60minutes each along X, Y and Z axis							
	IMPACT	196.1m/s ² (20G), 11ms, once each along X, Y and Z axis							
SAFETY	AGENCY APPROVALS	UL60950-1, C-UL (CSA60950-1), EN62368-1							
OTHERS	CASE SIZE/WEIGHT	33.0X9.5X13.5mm [1.3X0.37X0.53 inches] (WXHXD) / 10g max	33.0X10.9X13.5mm [1.3X0.43X0.53 inches] (WXHXD) / 12g max	33.0X8.0X22.9mm [1.3X0.31X0.9 inches] (WXHXD) / 15g max	33.0X12.7X13.5mm [1.3X0.5X0.53 inches] (WXHXD) / 12g max	38.0X8.5X27.7mm [1.5X0.33X1.09 inches] (WXHXD) / 22g max	33.0X12.7X22.9mm [1.3X0.5X0.9 inches] (WXHXD) / 14g max	38.0X13.8X27.7mm [1.5X0.54X1.09 inches] (WXHXD) / 21g max	
	COOLING METHOD	Convection / Forced air							

*1 At rated input (DC12V) and rated output (1.2V) Ta=25°C.
 *2 Output voltage is adjusted to the minimum when TRM is opened.
 *3 Ripple and ripple noise is measured by using measuring board with ceramic capacitor at 50mm from output pin.
 *4 Drift is the change in DC output for an eight hour period after a half - hour warm - up at 25°C, with the input voltage held.
 *5 Output voltage setting is added line regulation and load regulation and temperature regulation used resistance of the 0.5% tolerance.
 *6 The start-up time when using the RC terminal is same as other BRFS.
 *7 The output voltage adjustment area determines by the input voltage.

External view

3. BRFS60

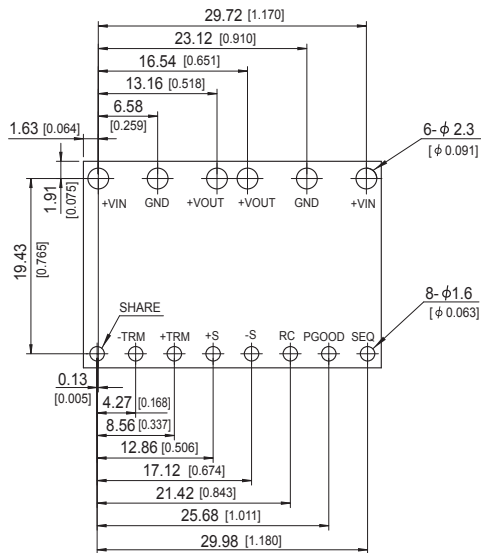
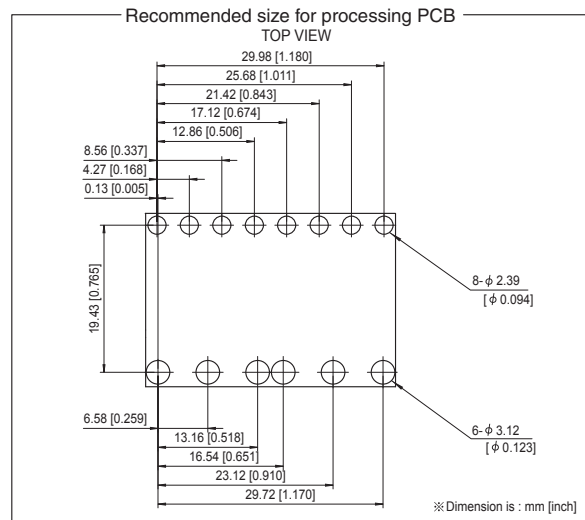
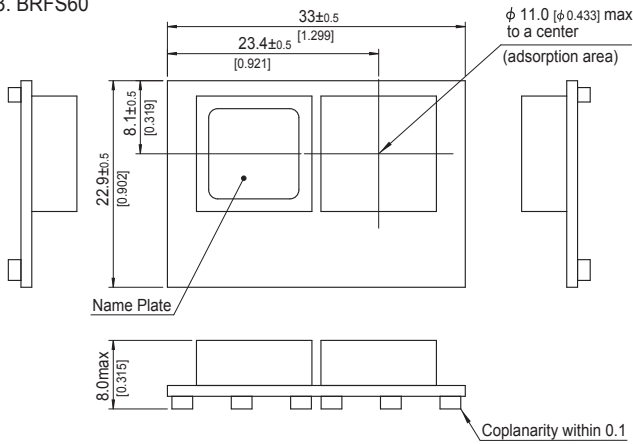

- ※ Tolerance : ± 0.3 [± 0.012]
- ※ Dimensions in mm, []=inches
- ※ Weight : 15g max
- ※ Terminal material : copper
- ※ Plating treatment of terminal : Lead free plating

External view

4. BRFS60S

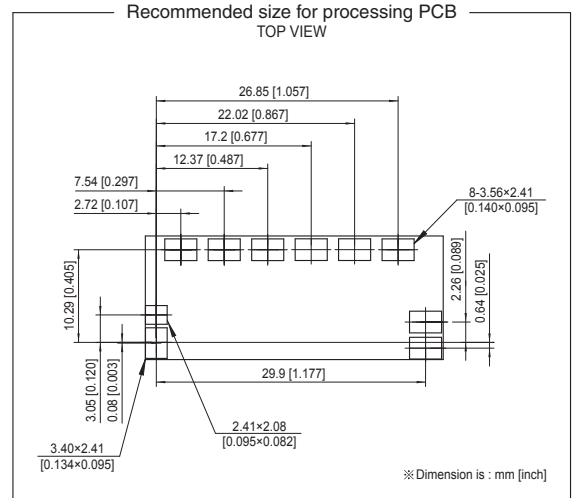
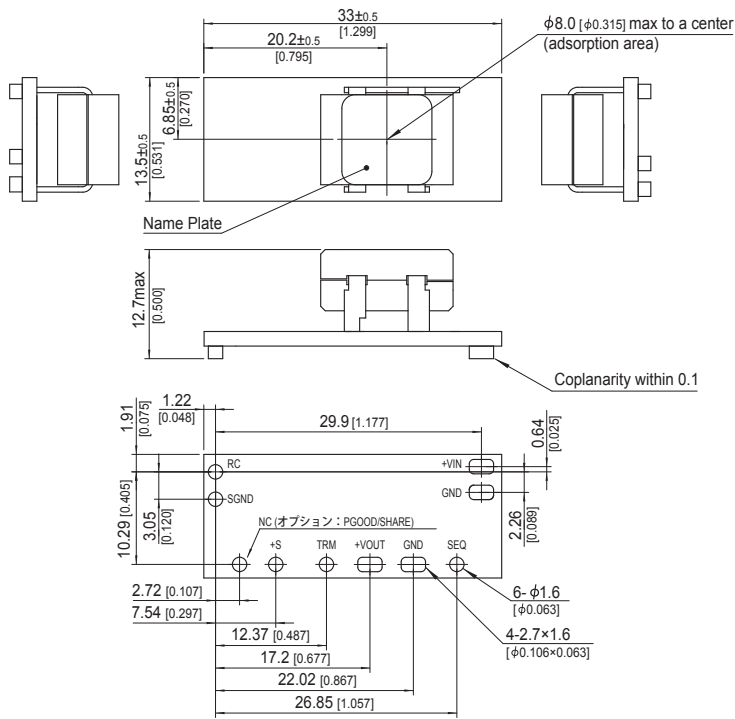

- ※ Tolerance : ±0.3 [±0.012]
- ※ Dimensions in mm, []=inches
- ※ Weight : 12g max
- ※ Terminal material : copper
- ※ Plating treatment of terminal : Lead free plating

5. BRFS100

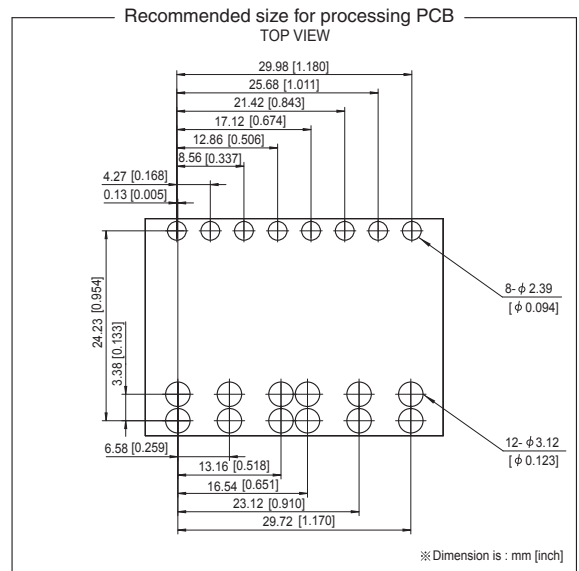
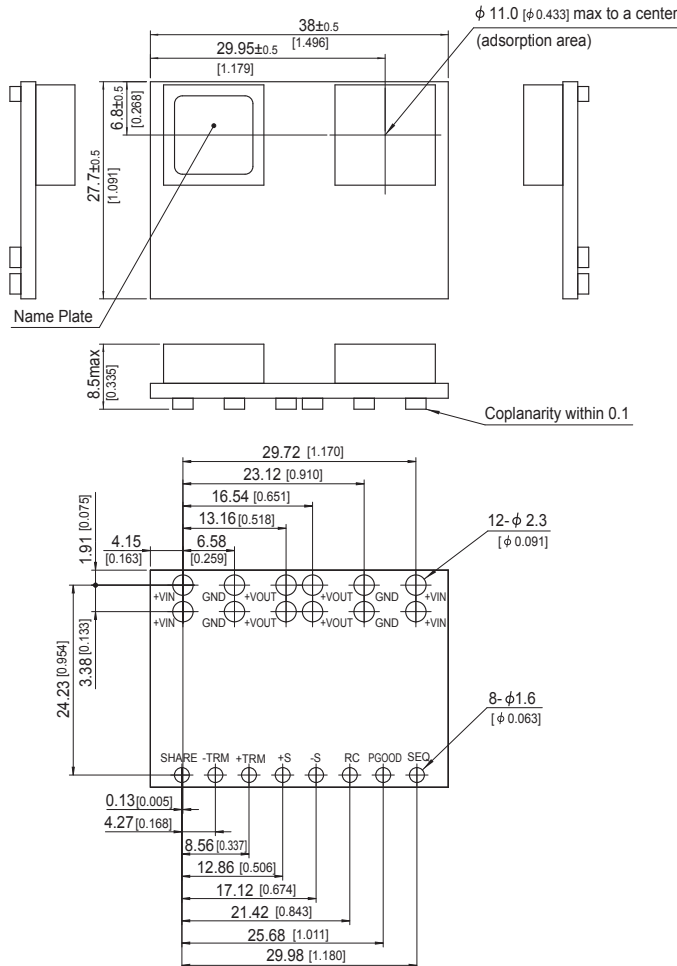

- ※ Tolerance : ±0.3 [±0.012]
- ※ Dimensions in mm, []=inches
- ※ Weight : 22g max
- ※ Terminal material : copper
- ※ Plating treatment of terminal : Lead free plating

External view

6. BRFS120

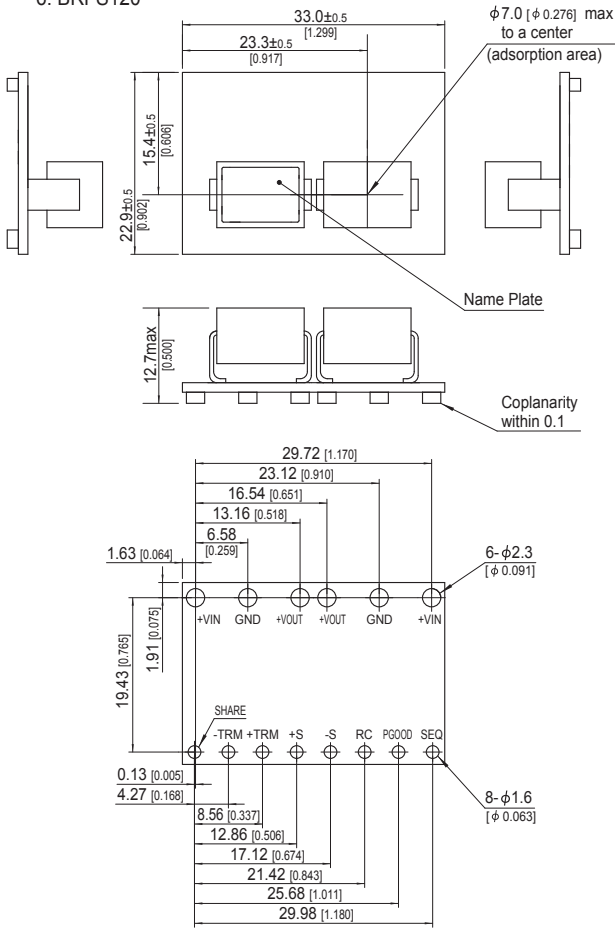

7. BRFS150

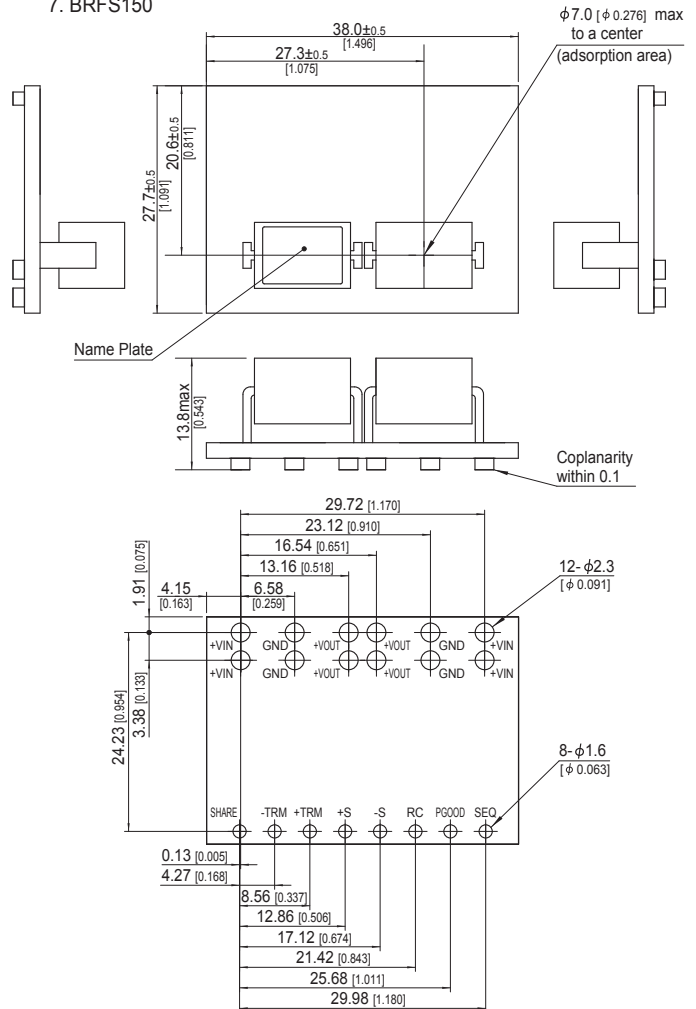

- ※ Tolerance : ±0.3 [±0.012]
- ※ Dimensions in mm, []=inches
- ※ Weight : 14g max
- ※ Terminal material : copper
- ※ Plating treatment of terminal : Lead free plating

- ※ Tolerance : ±0.3 [±0.012]
- ※ Dimensions in mm, []=inches
- ※ Weight : 21g max
- ※ Terminal material : copper
- ※ Plating treatment of terminal : Lead free plating

Recommended size for processing PCB TOP VIEW

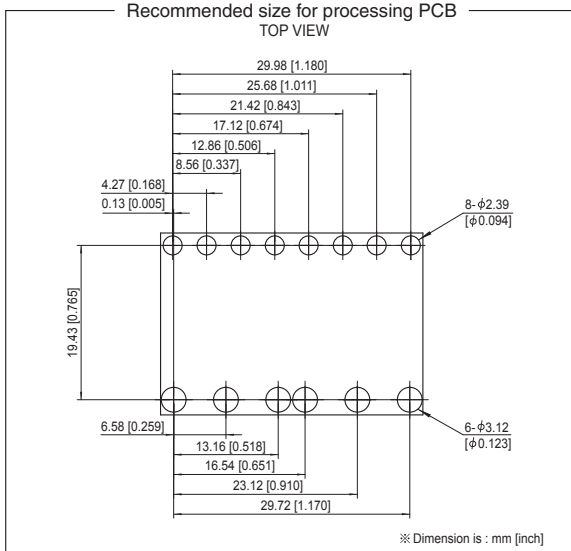

Recommended size for processing PCB TOP VIEW

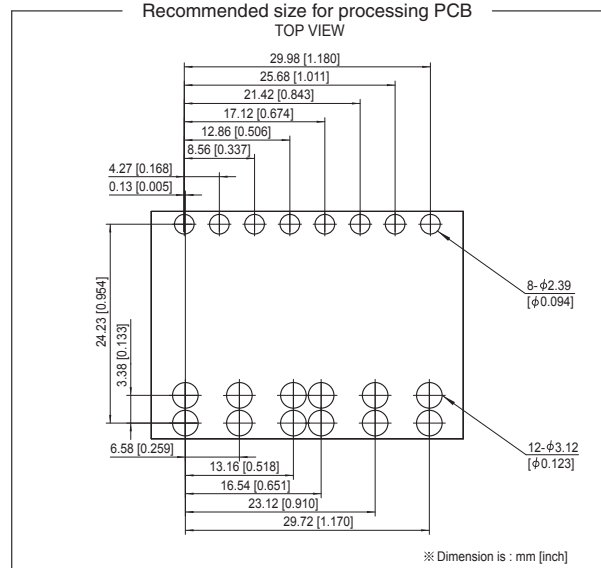

BRDS

BRD S 100 -

① ② ③ ④ ⑤

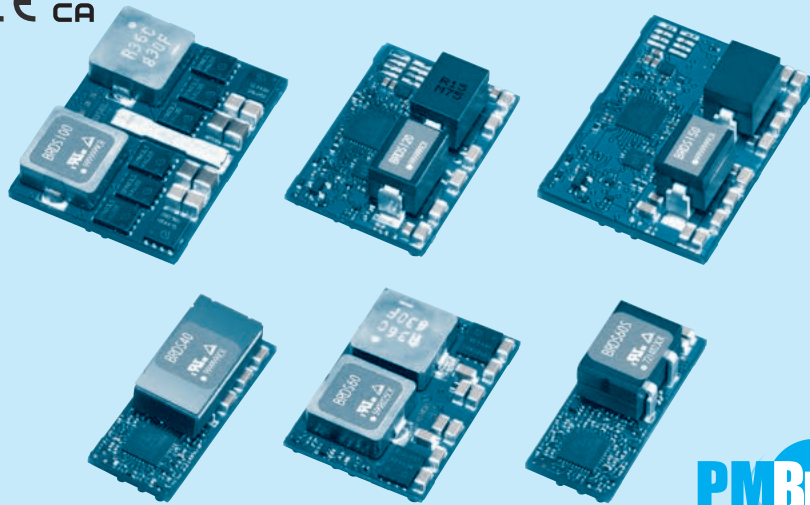

- ① Series name
- ② Single output
- ③ Output current
40:40A
60:60A
100:100A
120:120A
150:150A
- ④ Type
Blank: Standard type
S: Small type (Only 60A)
- ⑤ Optional
R: Positive logic remote on/off

MODEL	BRDS40	BRDS60	BRDS60S	BRDS100	BRDS120	BRDS150
MAX OUTPUT CURRENT[A]	40.0	60.0	60.0	100.0	120.0	150.0
DC OUTPUT	0.6 - 2.0V	0.7 - 2.0V	0.6 - 2.0V	0.7 - 2.0V	0.6 - 1.8V	0.6 - 1.8V *6

SPECIFICATIONS

	MODEL	BRDS40	BRDS60	BRDS60S	BRDS100	BRDS120	BRDS150
INPUT	VOLTAGE[V]	DC4.5 - 14.0					
	CURRENT[A]	*1 4.52 typ	6.82 typ	6.71 typ	11.24 typ	13.50 typ	16.90 typ
	EFFICIENCY[%]	*1 88.5 typ	88.0 typ	89.5 typ	89.0 typ	89.0 typ	89.0 typ
OUTPUT	VOLTAGE[V]	*2 0.6 - 2.0	0.7 - 2.0	0.6 - 2.0	0.7 - 2.0	0.6 - 1.8	0.6 - 1.8 *6
	CURRENT[A]	40	60	60	100	120	150
	LINE REGULATION[mV]	5					
	LOAD REGULATION[mV]	5					
	RIPPLE[mVp-p]	*3 25					
	RIPPLE NOISE[mVp-p]	*3 50					
	OUTPUT VOLTAGE SETTING [%Vo]	±1					
	DRIFT[mV]	*4 5					
	START-UP TIME[ms]	12.0 typ					
	OUTPUT VOLTAGE ADJUSTMENT RANGE [V]	Adjustable by external resistor					
PROTECTION CIRCUIT AND OTHERS	OVERCURRENT PROTECTION	Works over 105% of rating (auto recovery type)					
	REMOTE SENSING	Available					
ISOLATION	REMOTE ON/OFF	Available Negative logic L:ON, H:OFF					
	INPUT-OUTPUT	non-isolated					
ENVIRONMENT	OPERATING TEMP., HUMID. AND ALTITUDE	-40 to +85°C, 20-95%RH (Non condensing) (Refer to "Derating") 3,000m (10,000feet) max					
	STORAGE TEMP., HUMID. AND ALTITUDE	-40 to +100°C, 20-95%RH (Non condensing), 9,000m (30,000feet) max					
	VIBRATION	10-55Hz, 49.0m/s ² (5G), 3minutes period, 60minutes each along X, Y and Z axis					
	IMPACT	196.1m/s ² (20G), 11ms, once each along X, Y and Z axis					
SAFETY	AGENCY APPROVALS	UL60950-1, C-UL (CSA60950-1), EN62368-1					
OTHERS	CASE SIZE/WEIGHT	33.0×10.9×13.5mm [1.3×0.43×0.53 inches] (W×H×D) / 12g max	33.0×8.0×22.9mm [1.3×0.31×0.9 inches] (W×H×D) / 15g max	33.0×12.7×13.5mm [1.3×0.5×0.53 inches] (W×H×D) / 12g max	38.0×8.5×27.7mm [1.5×0.33×1.09 inches] (W×H×D) / 22g max	33.0×12.7×22.9mm [1.3×0.5×0.9 inches] (W×H×D) / 14g max	38.0×13.8×27.7mm [1.5×0.54×1.09 inches] (W×H×D) / 21g max
	COOLING METHOD	Convection / Forced air					

*1 At rated input (DC12V) and rated output (1.2V) Ta=25°C.
 *2 Output voltage is adjusted to the minimum when TRM is opened.
 *3 Ripple and ripple noise is measured by using measuring board with ceramic capacitor at 50mm from output pin.
 *4 Drift is the change in DC output for an eight hour period after a half - hour warm - up at 25°C, with the input voltage held.
 *5 Output voltage setting is added line regulation and load regulation and temperature regulation used resistance of the 0.5% tolerance.
 *6 The output voltage adjustment area determines by the input voltage.
 * This product is subject to a license from PAI Capital LLC related to digital power technology patents owned by PAI Capital LLC.

External view

3. BRDS60

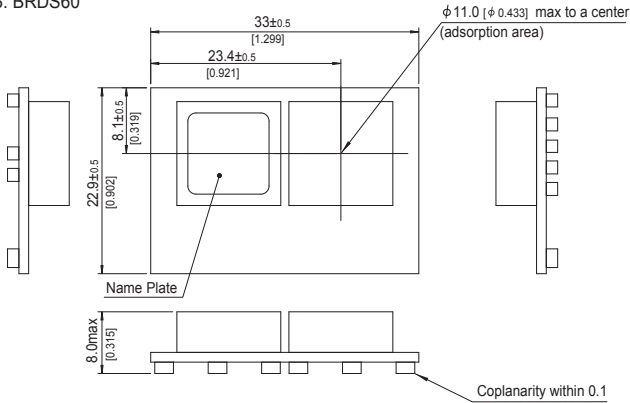

4. BRDS100

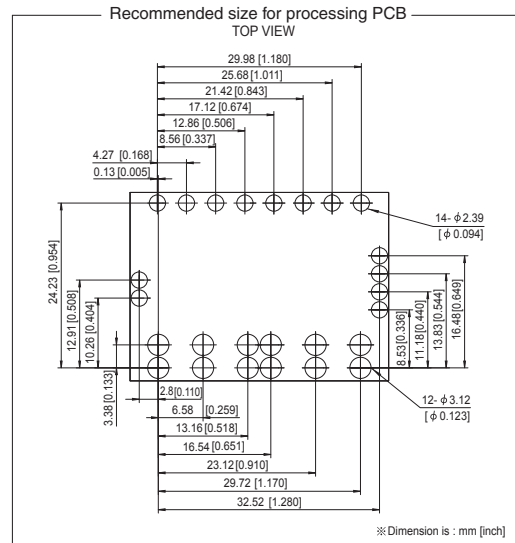
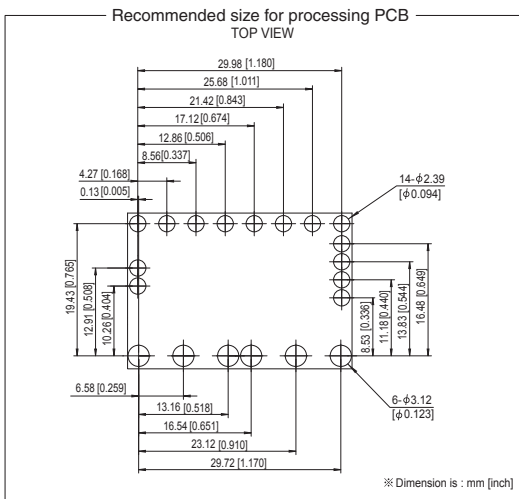
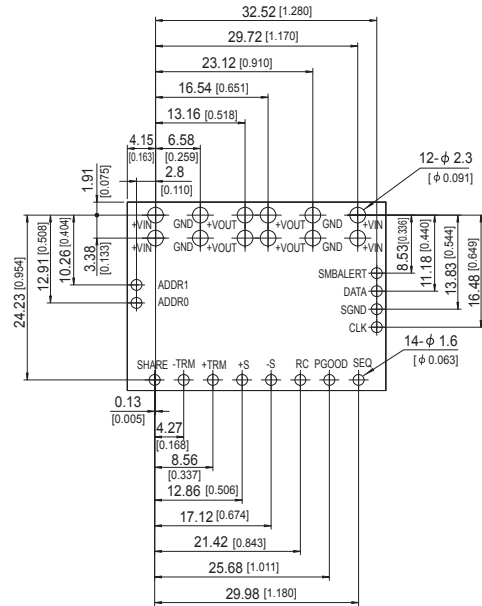
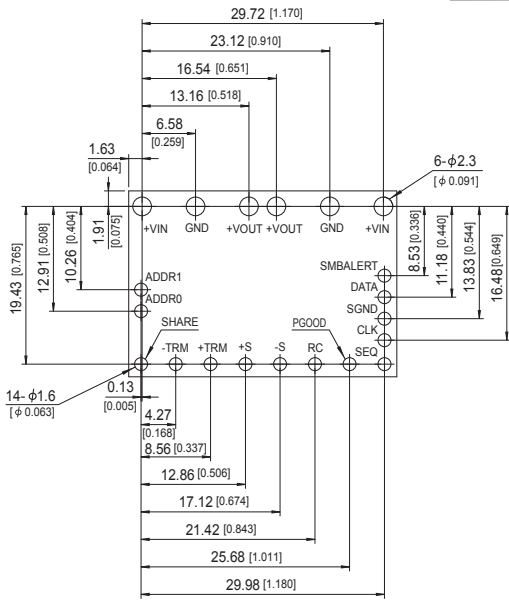
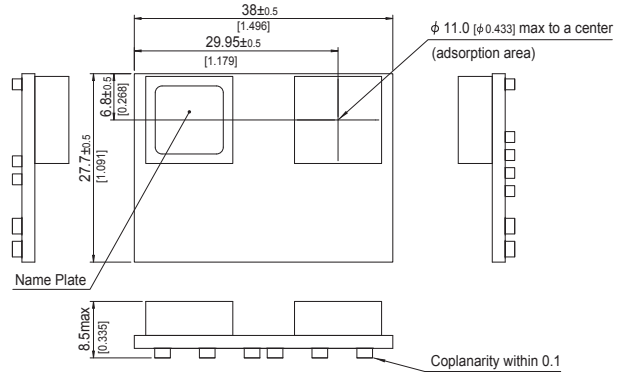

- ※ Tolerance : ±0.3 [±0.012]
- ※ Dimensions in mm, []=inches
- ※ Weight : 15g max
- ※ Terminal material : copper
- ※ Plating treatment of terminal : Lead free plating

- ※ Tolerance : ±0.3 [±0.012]
- ※ Dimensions in mm, []=inches
- ※ Weight : 22g max
- ※ Terminal material : copper
- ※ Plating treatment of terminal : Lead free plating

External view

5. BRDS120

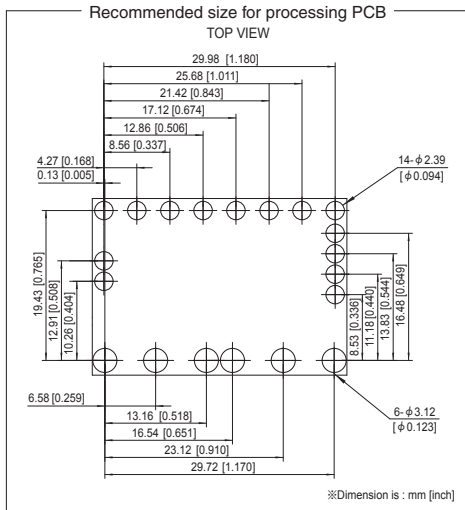
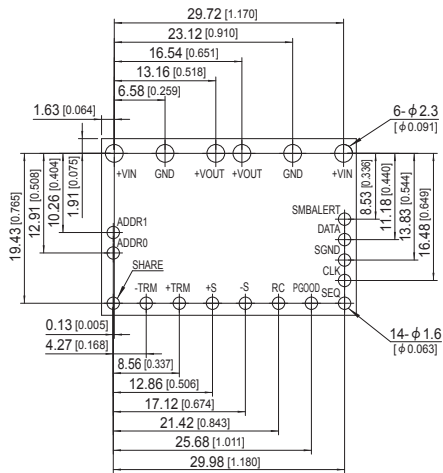
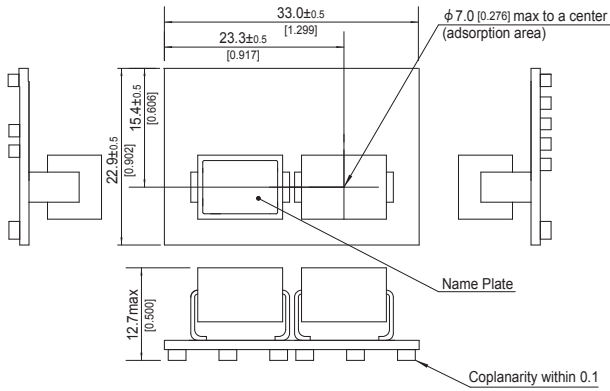

- * Tolerance : ± 0.3 [± 0.012]
- * Dimensions in mm, [] =inches
- * Weight : 14g max
- * Terminal material : copper
- * Plating treatment of terminal : Lead free plating

6. BRDS150

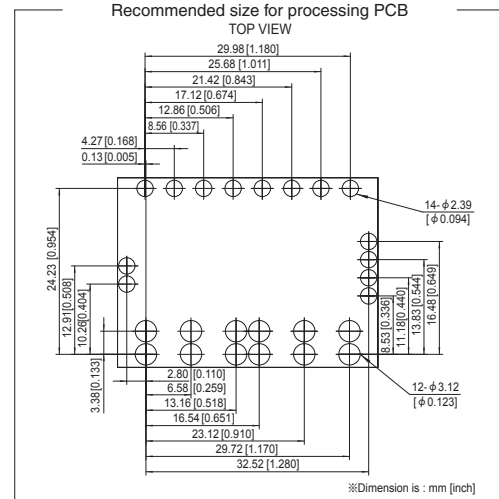
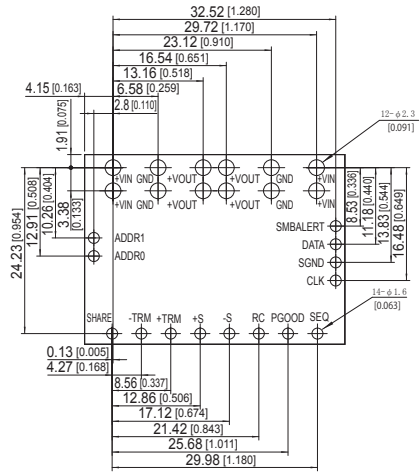
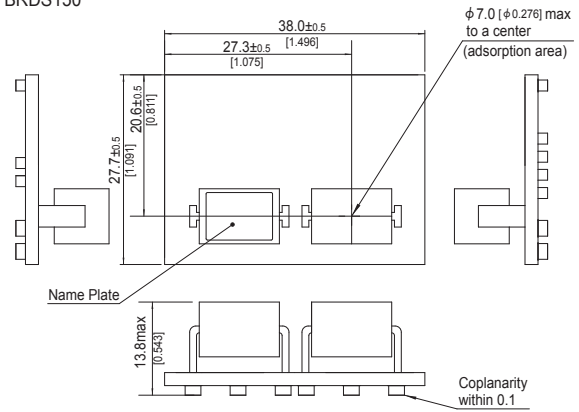

- * Tolerance : ± 0.3 [± 0.012]
- * Dimensions in mm, [] =inches
- * Weight : 21g max
- * Terminal material : copper
- * Plating treatment of terminal : Lead free plating

Pin Connection

●BRFS30/40/60S

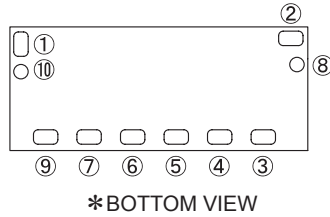

Pin No.	Pin Connection	Function
①	RC	Remote ON/OFF
②	+VIN	+DC input
③	SEQ	Control of Start up time and turn
④	GND	GND (-DC input, -DC output)
⑤	+VOUT	+DC output
⑥	TRM	Adjustment of output voltage
⑦	+S	+Remote sensing
⑧	GND	GND (-DC input, -DC output)
⑨	NC(PGOOD/ SHARE)	NC (optional : Power good, SHARE (BRFS40/60S))
⑩	SGND	Signal GND

●BRFS60/100/120/150

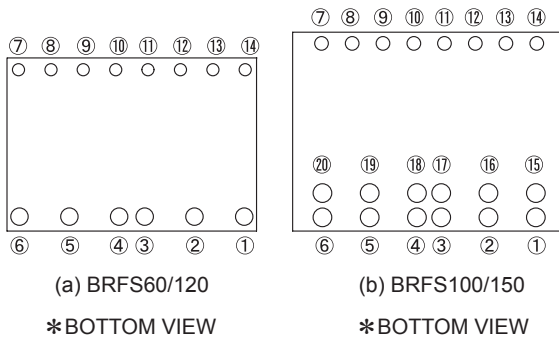

Pin No.	Pin Connection	Function
① (15)	+VIN	+DC input
② (16)	GND	GND (-DC input, -DC output)
③ (17)	+VOUT	+DC output
④ (18)	+VOUT	+DC output
⑤ (19)	GND	GND (-DC input, -DC output)
⑥ (20)	+VIN	+DC input
⑦	SEQ	Control of Start up time and turn
⑧	PGOOD	Power good
⑨	RC	Remote ON/OFF
⑩	-S	-Remote sensing
⑪	+S	+Remote sensing
⑫	+TRM	+Adjustment of output voltage
⑬	-TRM	-Adjustment of output voltage
⑭	SHARE	Parallel operation

●BRDS40/60S

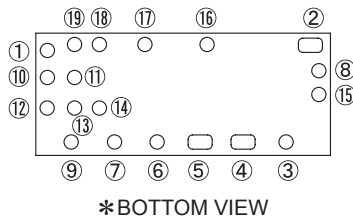

Pin No.	Pin Connection	Function
①	RC	Remote ON/OFF
②	+VIN	+DC input
③	SEQ	Control of Start up time and turn
④	GND	GND (-DC input, -DC output)
⑤	+VOUT	+DC output
⑥	TRM	Adjustment of output voltage
⑦	+S	+Remote sensing
⑧	GND	GND (-DC input, -DC output)
⑨	SHARE	Parallel operation
⑩	SGND	Signal GND
⑪	SGND	Signal GND
⑫	-S	-Remote sensing
⑬	CLK	PMBus communication clock input
⑭	DATA	PMBus communication data input & output
⑮	NC/SYNC	NC/Switching frequency synchronization (BRDS40/60S)
⑯	PGOOD	Power good
⑰	SMBALERT	PMBus alarm output
⑱	ADDR0	Address setting
⑲	ADDR1	Address setting

Pin Configuration

●BRDS60/100/120/150

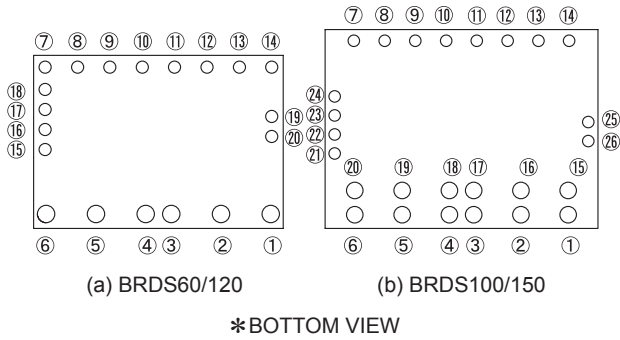

Pin No.		Pin Connection	Function
BRDS60 /120	BRDS100 /150		
①	① ⑮	+VIN	+DC input
②	② ⑯	GND	GND (-DC input, -DC output)
③	③ ⑰	+VOUT	+DC output
④	④ ⑱	+VOUT	+DC output
⑤	⑤ ⑲	GND	GND (-DC input, -DC output)
⑥	⑥ ⑳	+VIN	+DC input
⑦	⑦	SEQ	Control of Start up time and turn
⑧	⑧	PGOOD	Power good
⑨	⑨	RC	Remote ON/OFF
⑩	⑩	-S	-Remote sensing
⑪	⑪	+S	+Remote sensing
⑫	⑫	+TRM	+Adjustment of output voltage
⑬	⑬	-TRM	-Adjustment of output voltage
⑭	⑭	SHARE	Parallel operation
⑮	⑰	SMBALERT	PMBus alarm output
⑯	⑱	DATA	PMBus communication data input & output
⑰	⑳	SGND	Signal GND
⑱	㉑	CLK	PMBus communication clock input
⑲	㉒	ADDR0	Address setting
⑳	㉓	ADDR1	Address setting

Implementation · Mounting Method

Mounting method

■The unit can be mounted in any direction. When two or more power supplies are used side by side, position them with proper intervals to allow enough air ventilation. The temperature around each power supply should not exceed the temperature range shown in “Derating”.

Automatic Mounting

■To mount BRFS/BRDS series automatically, use the coil area near the center of the PCB as an adsorption point. Please see the External View for details of the adsorption point.

Soldering

- Right figure shows condition for reflow of BRFS/BRDS series. Please make sure that the temperature of pin shown in (a),(b) and(c) do not exceed the temperatures shown in right figure .
- While soldering, having vibration or impact on the unit should be avoided, because of solder melting.
- Please do not do the implementation except the reflow.
- Because some parts drops , please do not do reflow of the back side.

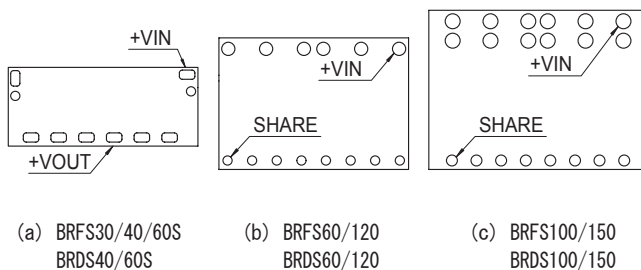
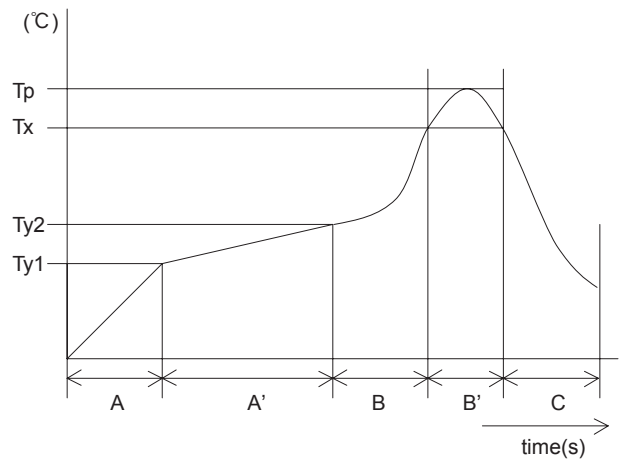

A	1.0 - 5.0°C/ s
A'	Ty1 : 160±10°C Ty2 : 180±10°C Ty1 - Ty2 : 120s max
B	1.0 - 5.0°C/ s
B'	Tp : Max245°C 10s max Tx : 220°C or more : 70s max
C	1.0 - 5.0°C/ s

Derating

■ Make sure the temperatures measurement locations shown from Instruction Manual 8 are on or under the derating curve in right figure. Ambient temperature must be kept at 85°C or under.

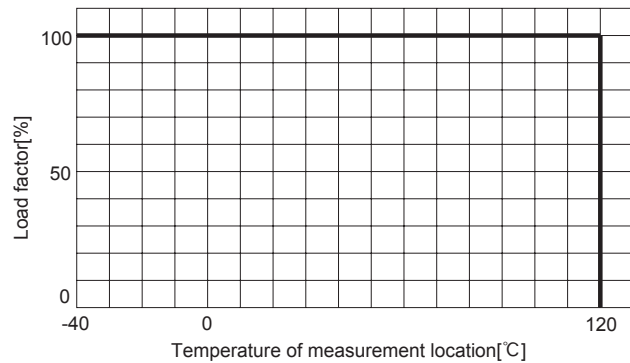

Instruction Manual

◆ It is necessary to read the “Instruction Manual” and “Before using our product” before you use our product.

Instruction Manual <https://www.cosel.co.jp/redirect/catalog/en/BRFS/>
 Instruction Manual <https://www.cosel.co.jp/redirect/catalog/en/BRDS/>
 Before using our product <https://en.cosel.co.jp/technical/caution/index.html>

BRFS



BRDS



NOTICE



Basic Characteristics Data

Model	Circuit method	Switching frequency [kHz] (reference)	Input current [A]	Inrush current protection	PCB/Pattern			Series/Parallel operation	
					Material	Single sided	Double sided	Series operation	Parallel operation
BRFS30	Buck Converter	300	*1	-	glass fabric base,epoxy resin	-	Multilayer	-	*3
BRFS40	Buck Converter	300	*1	-	glass fabric base,epoxy resin	-	Multilayer	-	*3
BRFS60	Buck Converter	300 *2	*1	-	glass fabric base,epoxy resin	-	Multilayer	-	*3
BRFS60S	Buck Converter	300 *2	*1	-	glass fabric base,epoxy resin	-	Multilayer	-	*3
BRFS100	Buck Converter	300 *2	*1	-	glass fabric base,epoxy resin	-	Multilayer	-	*3
BRFS120	Buck Converter	400 *2	*1	-	glass fabric base,epoxy resin	-	Multilayer	-	*3
BRFS150	Buck Converter	400 *2	*1	-	glass fabric base,epoxy resin	-	Multilayer	-	*3
BRDS40	Buck Converter	300	*1	-	glass fabric base,epoxy resin	-	Multilayer	-	*3
BRDS60	Buck Converter	300 *2	*1	-	glass fabric base,epoxy resin	-	Multilayer	-	*3
BRDS60S	Buck Converter	300 *2	*1	-	glass fabric base,epoxy resin	-	Multilayer	-	*3
BRDS100	Buck Converter	300 *2	*1	-	glass fabric base,epoxy resin	-	Multilayer	-	*3
BRDS120	Buck Converter	400 *2	*1	-	glass fabric base,epoxy resin	-	Multilayer	-	*3
BRDS150	Buck Converter	400 *2	*1	-	glass fabric base,epoxy resin	-	Multilayer	-	*3

*1 Refer to Specification.

*2 These models have 2 phase interleave, and the ripple frequency is double the switching frequency.

*3 Refer to the Instruction Manual.



CHS-series

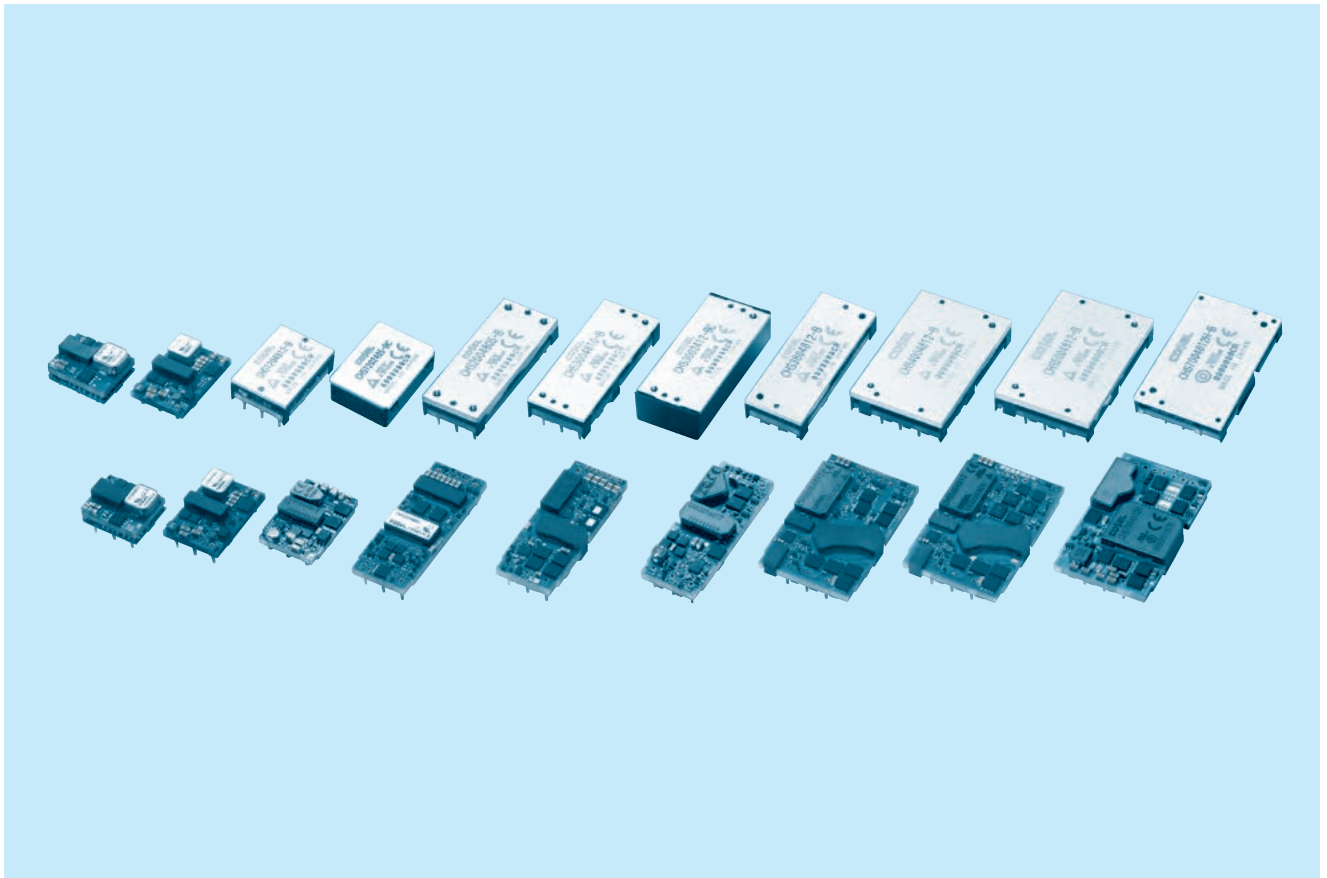

CHS

■ Feature

- High efficiency 96% (CHS7004812H)
- Compact DC-DC Converter, "BRICK SIZE" which has been standard size for Telecommunication Market
- High density
- High reliability : not built-in aluminum and tantalum electrolytic capacitor
- Built-in overcurrent, overvoltage and thermal protection circuits
- Built-in remote ON/OFF

■ CE marking

- Low Voltage Directive
- RoHS Directive

■ UKCA marking

- Electrical Equipment Safety Regulations
- RoHS Regulations

■ Safety agency approvals

- UL60950-1, C-UL, EN62368-1 (CHS60, CHS80, CHS120, CHS200, CHS300, CHS380, CHS400, CHS500)
- UL62368-1, C-UL, EN62368-1 (CHS700)

■ 5-year warranty

CHS60

CH S 60 48 3R3 -□

① ② ③ ④ ⑤ ⑥

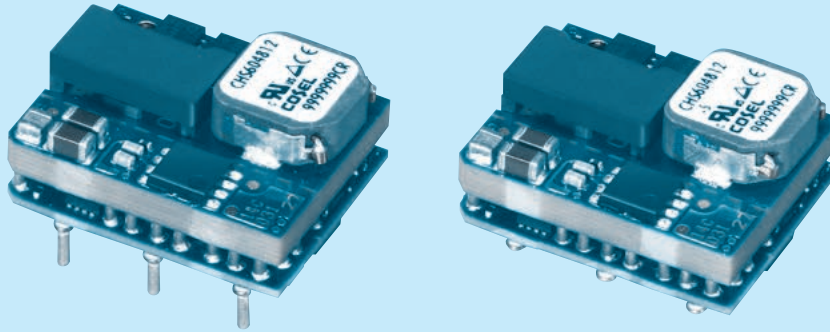

- ① Series name
- ② Single output
- ③ Output power
- ④ Input voltage
48:DC36 - 76V
- ⑤ Output voltage
3R3:3.3V
05:5.0V
12:12V
- ⑥ Optional
R :with Remote ON/OFF
Positive logic control
U :Shut down in protection
circuit working
S :SMD

MODEL	CHS60483R3	CHS604805	CHS604812
MAX OUTPUT WATTAGE[W]	59.4	60.0	72.0
DC OUTPUT	3.3V 18A	5V 12A	12V 6A

SPECIFICATIONS

	MODEL	CHS60483R3	CHS604805	CHS604812	
INPUT	VOLTAGE[V]	DC36 - 76			
	CURRENT[A]	*1 1.36typ	1.34typ	1.63typ	
	EFFICIENCY[%]	*1 91.5typ	93.0typ	92.5typ	
OUTPUT	VOLTAGE[V]	3.3	5	12	
	CURRENT[A]	18	12	6	
	LINE REGULATION[mV]	10max			
	LOAD REGULATION[mV]	10max			
	RIPPLE	[mVrms] *2	30max	30max	50max
		[mVp-p] *2	80max	100max	150max
	RIPPLE NOISE[mVp-p] *2	120max	150max	180max	
	TEMPERATURE REGULATION[mV]	66max	100max	240max	
	DRIFT[mV]	*3 16max	20max	40max	
	START-UP TIME[ms]	50max (DCIN 48V, Io=100%)			
	OUTPUT VOLTAGE ADJUSTMENT RANGE *4	Fixed (TRM pin open), adjustable by external resistor			
-10% / +15%		-10% / +20%	-20% / +10%		
OUTPUT VOLTAGE SETTING	±1.6%				
PROTECTION CIRCUIT AND OTHERS	OVERCURRENT PROTECTION	Works over 105% of rating (Auto restart)			
	OVERVOLTAGE PROTECTION	120% - 140% (Auto restart)	125% - 145% (Auto restart)	115% - 135% (Auto restart)	
	REMOTE SENSING	Provided			
	REMOTE ON/OFF	Provided (Negative Logic L : ON, H :OFF)			
ISOLATION	INPUT-OUTPUT	DC2,250V or AC1,000V 1minute, Cutoff current = 10mA, DC500V 50MΩ min (20±15°C)			
ENVIRONMENT	OPERATING TEMP., HUMID. AND ALTITUDE	-40 to +85°C, 20 - 95%RH (Non condensing) (Refer to "Derating"), 5,000m (16,000 feet) max			
	STORAGE TEMP., HUMID. AND ALTITUDE	-40 to +100°C, 20 - 95%RH (Non condensing), 9,000m (30,000 feet) max			
	VIBRATION	10 - 55Hz, 49.0m/s ² (5G), 3minutes period, 60minutes each along X, Y and Z axis			
	IMPACT	196.1m/s ² (20G), 11ms, once each along X, Y and Z axis			
SAFETY	AGENCY APPROVALS	UL60950-1, C-UL (CSA60950-1), EN62368-1			
OTHERS	CASE SIZE/WEIGHT	19.05 X 12.7 X 23.36mm [0.75 X 0.5 X 0.92 inches] (W X H X D) / 15g max			
	COOLING METHOD	Convection / Forced air			

*1 At rated input (DC48V) and rated load. Ta=25°C, 2m/s.
 *2 Ripple and ripple noise is measured by using measuring board with ceramic capacitor 22 μF.
 *3 Drift is the change in DC output for an eight hour period after a half-hour warm-up at 25°C, with the input voltage held constant at the rated input/output.
 *4 Refer to the instruction manual for input voltage derating.

External view

1. DIP

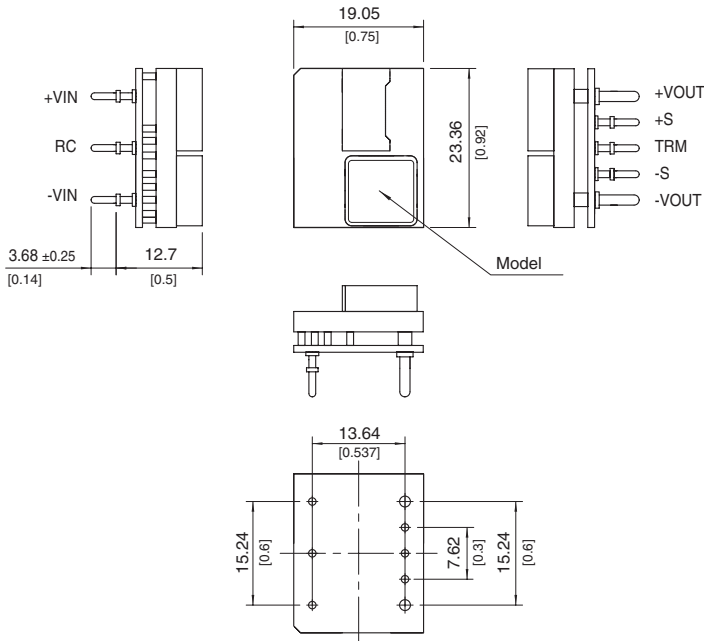

※ Tolerance: ± 0.5 [± 0.02]
 ※ Dimensions in mm, []=inches

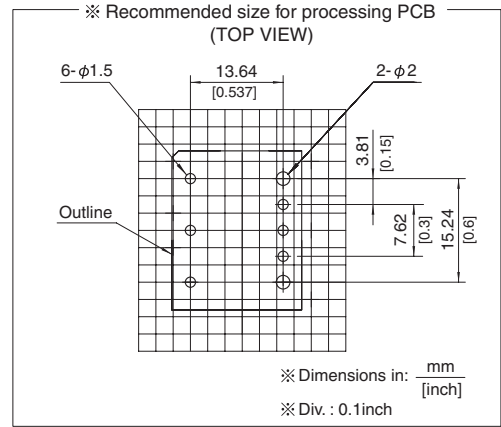
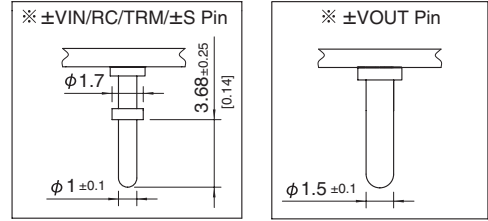

2. SMD (option S)

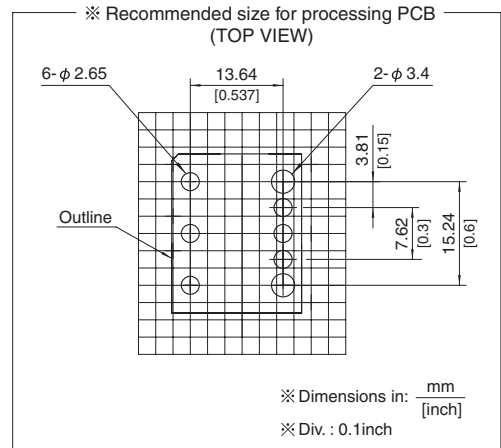
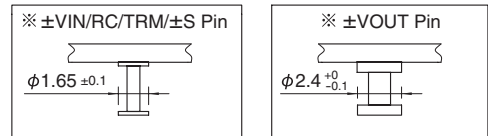
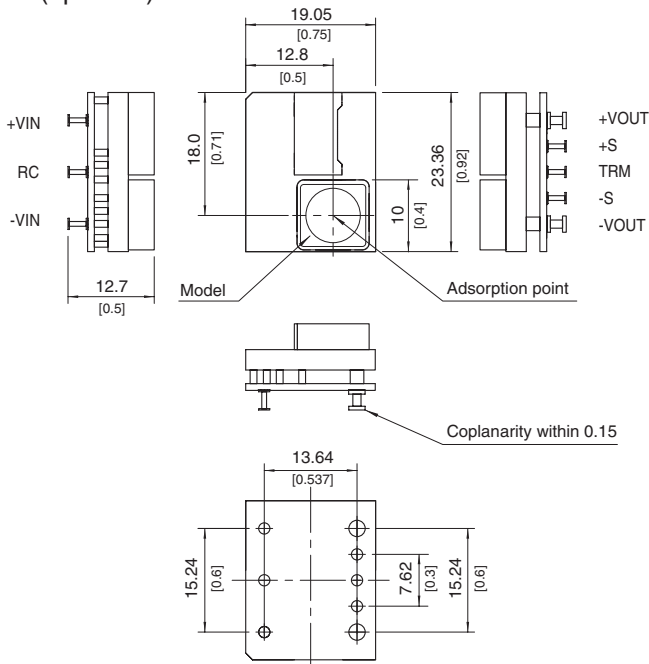

CHS80

CH S 80 48 05 - □

① ② ③ ④ ⑤ ⑥



RoHS

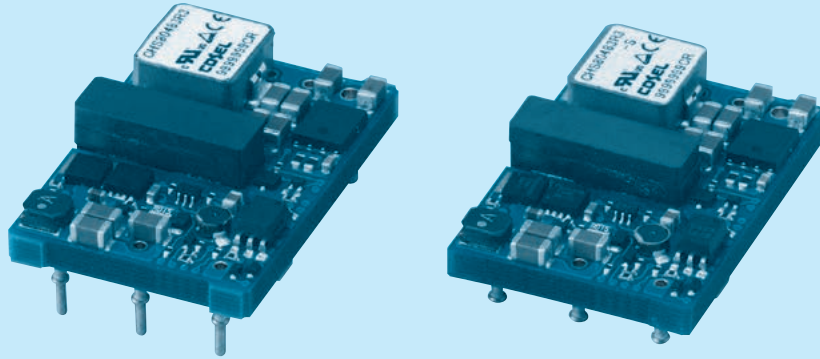

- ① Series name
- ② Single output
- ③ Output power
- ④ Input voltage
48:DC36-76V
- ⑤ Output voltage
3R3:3.3V
05:5.0V
12:12V
- ⑥ Optional
R :with Remote ON/OFF
Positive logic control
U :Shut down in protection
circuit working
S :SMD

MODEL	CHS80483R3	CHS804805	CHS804812
MAX OUTPUT WATTAGE[W]	82.5	80.0	90.0
DC OUTPUT	3.3V 25A	5.0V 16A	12V 7.5A

SPECIFICATIONS

	MODEL	CHS80483R3	CHS804805	CHS804812	
INPUT	VOLTAGE[V]	DC36 - 76			
	CURRENT[A]	*1 1.86typ	1.81typ	2.03typ	
	EFFICIENCY[%]	*1 92typ	92typ	92typ	
OUTPUT	VOLTAGE[V]	3.3	5	12	
	CURRENT[A]	25	16	7.5	
	LINE REGULATION[mV]	10max			
	LOAD REGULATION[mV]	10max			
	RIPPLE	[mVrms] *2	30max	30max	50max
		[mVp-p] *2	80max	100max	150max
	RIPPLE NOISE[mVp-p]	*2 120max	150max	180max	
	TEMPERATURE REGULATION[mV]	66max	100max	240max	
	DRIFT[mV]	*3 16max	20max	40max	
	START-UP TIME[ms]	200max (DCIN 48V, Io=100%)			
	OUTPUT VOLTAGE ADJUSTMENT RANGE	*4 Fixed (TRM pin open), adjustable by external resistor -10% / +15%		-10% / +20%	-10% / +10%
OUTPUT VOLTAGE SETTING	± 1.6%				
PROTECTION CIRCUIT AND OTHERS	OVERCURRENT PROTECTION	Works over 105% of rating (Auto restart)			
	OVERVOLTAGE PROTECTION	120% - 140% (Auto restart)	125% - 145% (Auto restart)	115% - 135% (Auto restart)	
	REMOTE SENSING	Provided			
	REMOTE ON/OFF	Provided (Negative logic L:ON, H:OFF)			
ISOLATION	INPUT-OUTPUT	DC2,250V or AC1,000V 1minute. Cutoff current = 10mA. DC500V 50MΩ min (20±15°C)			
ENVIRONMENT	OPERATING TEMP.,HUMID.AND ALTITUDE	-40 to +85°C, 20 - 95%RH (Non condensing) (Refer to "Derating"), 3,000m (10,000feet) max			
	STORAGE TEMP.,HUMID.AND ALTITUDE	-40 to +100°C, 20 - 95%RH (Non condensing), 9,000m (30,000feet) max			
	VIBRATION	10 - 55Hz, 49.0m/s ² (5G), 3minutes period, 60minutes each along X, Y and Z axis			
	IMPACT	196.1m/s ² (20G), 11ms, once each along X, Y and Z axis			
SAFETY	AGENCY APPROVALS	UL60950-1, C-UL (CSA60950-1), EN62368-1			
OTHERS	CASE SIZE/WEIGHT	33.0 x 10.5 x 22.76mm [1.3 x 0.41 x 0.9 inches] (W x H x D) / 21g max			
	COOLING METHOD	Convection / Forced air			

*1 At rated input(DC48V) and rated load. Ta=25°C, 2m/s.

*2 Ripple and ripple noise is measured by using measuring board with ceramic capacitor 22 μF.

*3 Drift is the change in DC output for an eight hour period after a half-hour warm-up at 25°C, with the input voltage held constant at the rated input/output.

*4 Refer to the instruction manual for input voltage derating.

External view

1. DIP

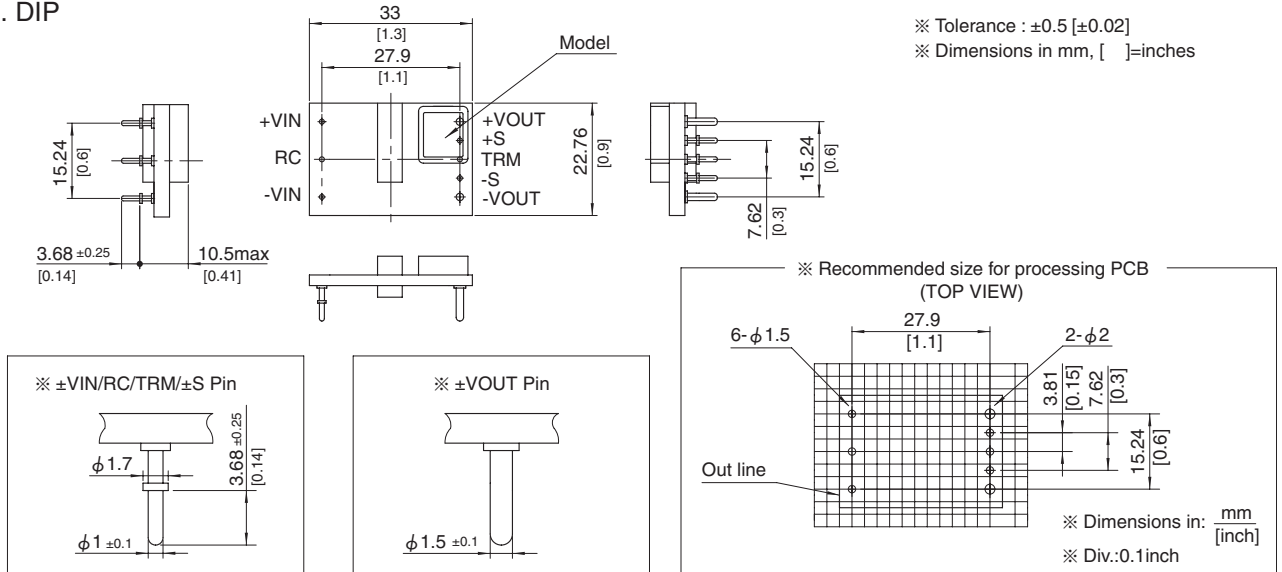

2. SMD (optionS)

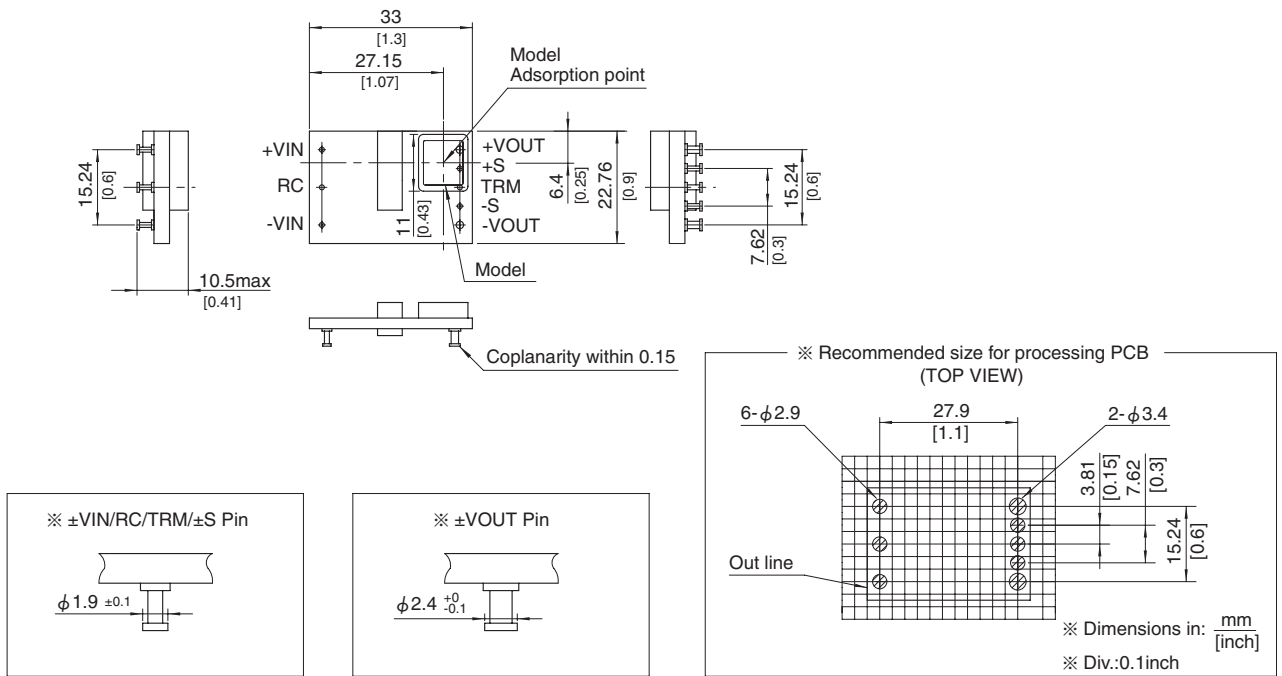

CHS120

CH S 120 48 05 - □

① ② ③ ④ ⑤ ⑥



RoHS

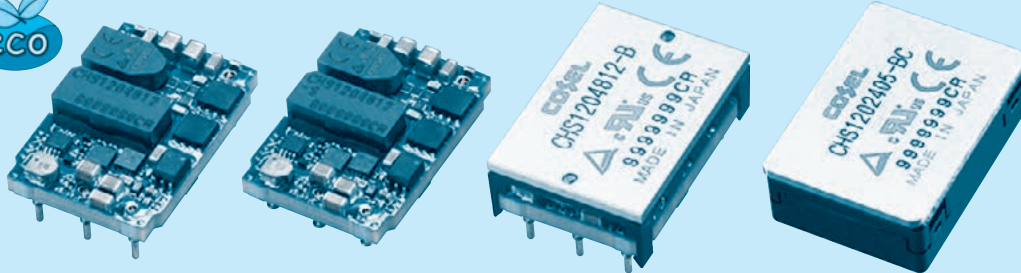

- ① Series name
- ② Single output
- ③ Output power
- ④ Input voltage
24:DC18 - 36V
48:DC36 - 76V
- ⑤ Output voltage
3R3:3.3V
05:5.0V
12:12V
15:15V
24:24V
- ⑥ Optional
R : with Remote ON/OFF
Positive logic control
U : Shut down in protection
circuit working
S : SMD
B : BasePlate option
BC: Baseplate and case option
(only CHS12024)
L2: Pin length 5.3mm
L5: 5pins option
(+S, -S, TRM less)

MODEL	CHS1202405	CHS1202412	CHS1202415	CHS1202424
MAX OUTPUT WATTAGE[W]	120.0	120.0	120.0	100.8
DC OUTPUT	5V 24A	12V 10A	15V 8A	24V 4.2A

SPECIFICATIONS

	MODEL	CHS1202405	CHS1202412	CHS1202415	CHS1202424	
INPUT	VOLTAGE[V]	DC18 - 36				
	CURRENT[A]	*1 5.41typ	5.47typ	5.50typ	4.65typ	
	EFFICIENCY[%]	*1 92.5typ	91.5typ	91typ	90.5typ	
OUTPUT	VOLTAGE[V]	5	12	15	24	
	CURRENT[A]	24	10	8	4.2	
	LINE REGULATION[mV]	10max	24max	30max	48max	
	LOAD REGULATION[mV]	10max	24max	30max	48max	
	RIPPLE	[mVrms] *2	40max	50max	60max	83max
		[mVp-p] *2	120max	150max	180max	250max
	RIPPLE NOISE[mVp-p]	*2 150max	180max	210max	280max	
	TEMPERATURE REGULATION[mV]	100max	240max	300max	480max	
	DRIFT[mV]	*3 20max	40max	50max	80max	
	START-UP TIME[ms]	50max (DCIN 24V, Io=100%)				
	OUTPUT VOLTAGE ADJUSTMENT RANGE *4	Fixed (TRM pin open), adjustable by external resistor				
			-10% / +20%	-10% / +10%	-10% / +5%	-10% / +10%
	OUTPUT VOLTAGE SETTING	±1.6%				
PROTECTION CIRCUIT AND OTHERS	OVERCURRENT PROTECTION	Works over 105% of rating (Auto restart)				
	OVERVOLTAGE PROTECTION	125% - 150% (Auto restart)	115% - 135% (Auto restart)	110% - 130% (Auto restart)	115% - 135% (Auto restart)	
	REMOTE SENSING	Provided				
	REMOTE ON/OFF	Provided (Negative logic L:ON, H:OFF)				

MODEL	CHS120483R3	CHS1204805	CHS1204812	CHS1204815	CHS1204824
MAX OUTPUT WATTAGE[W]	99.0	120.0	120.0	120.0	100.8
DC OUTPUT	3.3V 30A	5V 24A	12V 10A	15V 8A	24V 4.2A

SPECIFICATIONS

	MODEL	CHS120483R3	CHS1204805	CHS1204812	CHS1204815	CHS1204824	
INPUT	VOLTAGE[V]	DC36 - 76					
	CURRENT[A]	*1 2.23typ	2.69typ	2.69typ	2.72typ	2.31typ	
	EFFICIENCY[%]	*1 92.5typ	93typ	93typ	92typ	91typ	
OUTPUT	VOLTAGE[V]	3.3	5	12	15	24	
	CURRENT[A]	30	24	10	8	4.2	
	LINE REGULATION[mV]	10max			30max	48max	
	LOAD REGULATION[mV]	10max			30max	48max	
	RIPPLE	[mVrms] *2	30max	30max	50max	60max	83max
		[mVp-p] *2	80max	100max	150max	180max	250max
	RIPPLE NOISE[mVp-p]	*2 120max	150max	180max	210max	280max	
	TEMPERATURE REGULATION[mV]	66max	100max	240max	300max	480max	
	DRIFT[mV]	*3 16max	20max	40max	50max	80max	
	START-UP TIME[ms]	50max (DCIN 48V, Io=100%)					
	OUTPUT VOLTAGE ADJUSTMENT RANGE *4	Fixed (TRM pin open), adjustable by external resistor					
			-10% / +15%	-10% / +20%	-10% / +10%	-10% / +5%	-10% / +10%
	OUTPUT VOLTAGE SETTING	±1.6%					
PROTECTION CIRCUIT AND OTHERS	OVERCURRENT PROTECTION	Works over 105% of rating (Auto restart)					
	OVERVOLTAGE PROTECTION	120% - 140% (Auto restart)	125% - 145% (Auto restart)	115% - 135% (Auto restart)	110% - 130% (Auto restart)	115% - 135% (Auto restart)	
	REMOTE SENSING	Provided					
	REMOTE ON/OFF	Provided (Negative logic L:ON, H:OFF)					

GENERAL SPECIFICATIONS

ISOLATION	INPUT-OUTPUT	DC2,250V or AC1,000V 1minute, Cutoff current = 10mA, DC500V 50MΩ min (20±15°C)
	INPUT-BASEPLATE *5 *6	DC2,250V or AC1,000V 1minute, Cutoff current = 10mA, DC500V 50MΩ min (20±15°C)
	OUTPUT-BASEPLATE *5 *6	AC500V 1minute, Cutoff current = 100mA, DC500V 50MΩ min (20±15°C)
ENVIRONMENT	OPERATING TEMP.,HUMID.AND ALTITUDE	-40 to +85°C, 20 - 95%RH (Non condensing) (Refer to "Derating"), 5,000m (16,000feet) max
	STORAGE TEMP.,HUMID.AND ALTITUDE	-40 to +100°C, 20 - 95%RH (Non condensing), 9,000m (30,000feet) max
	VIBRATION	10 - 55Hz, 49.0m/s ² (5G), 3minutes period, 60minutes each along X, Y and Z axis
	IMPACT	196.1m/s ² (20G), 11ms, once each along X, Y and Z axis
SAFETY	AGENCY APPROVALS	UL60950-1, C-UL (CSA60950-1), EN62368-1
OTHERS	CASE SIZE/WEIGHT	33.0×10.5×22.86mm [1.3×0.41×0.9 inches] (W×H×D) / 19g max
		33.5×12.7×23.36mm [1.32×0.5×0.92 inches] (W×H×D) / 28g max *5
		36.5×12.7×26.5mm [1.44×0.5×1.04 inches] (W×H×D) / 32g max *6
	COOLING METHOD	Convection/Forced air/Conduction

*1 At rated input (DC24V, DC48V) and rated load. Ta=25°C, 2m/s.
 *2 Ripple and ripple noise is measured by using measuring board with ceramic capacitor 22 μF.
 *3 Drift is the change in DC output for an eight hour period after a half-hour warm-up at 25°C.
 *4 Refer to the instruction manual for input voltage derating.
 *5 BasePlate Option.
 *6 Baseplate and case option.

External view

1. DIP

※ Tolerance : ±0.5
 ※ Dimensions in mm, []=inches

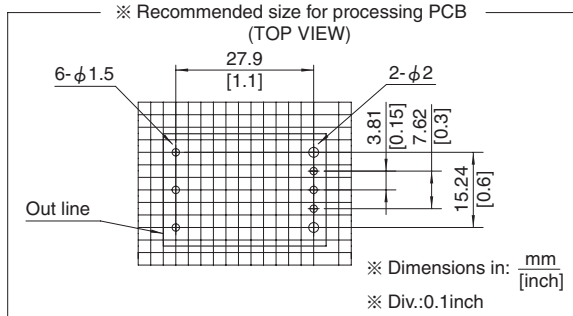
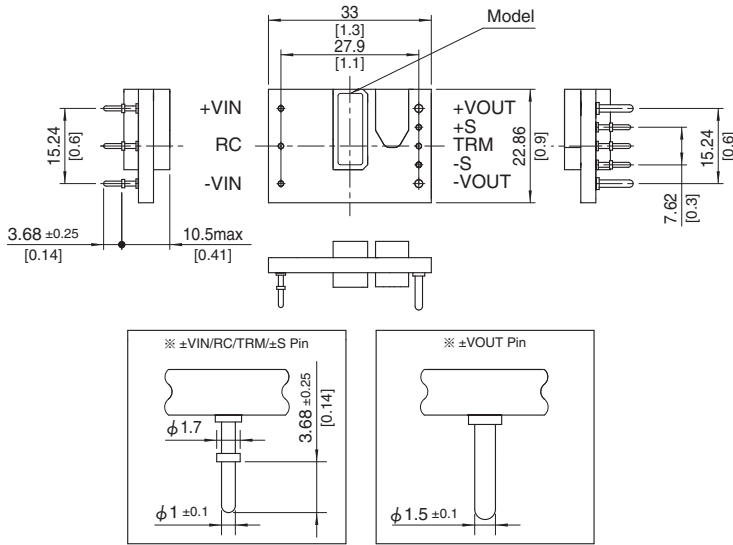

2. SMD (option S)

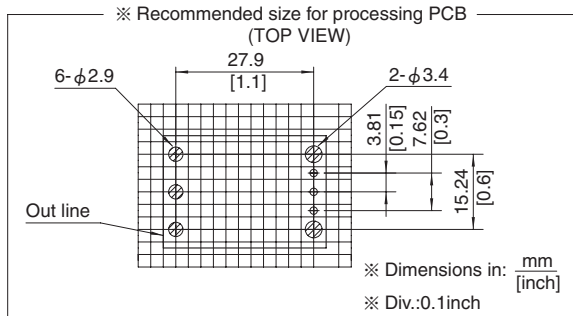
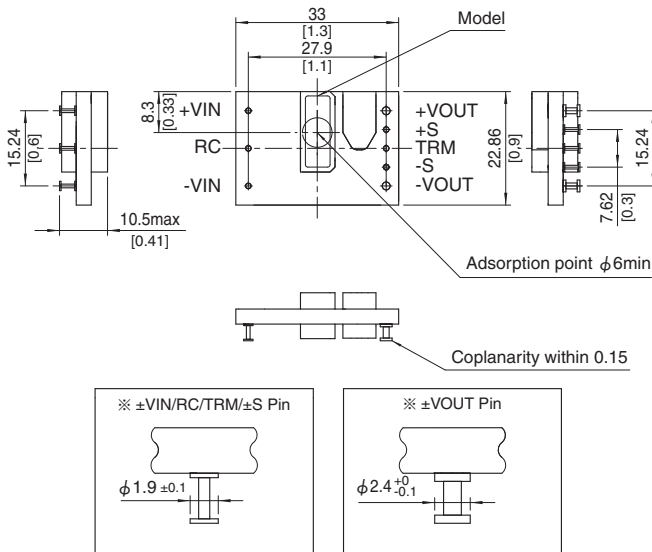

3. BasePlate (option B)

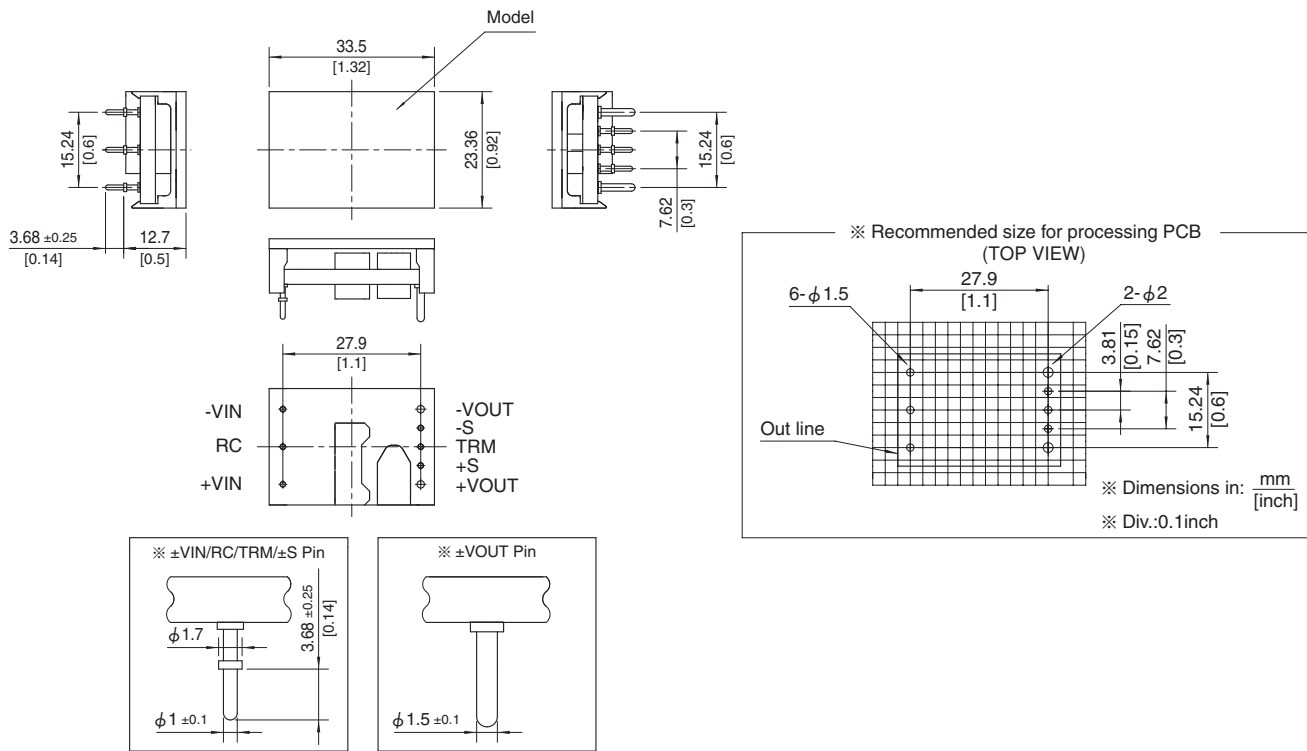

4. Baseplate and case (option BC)

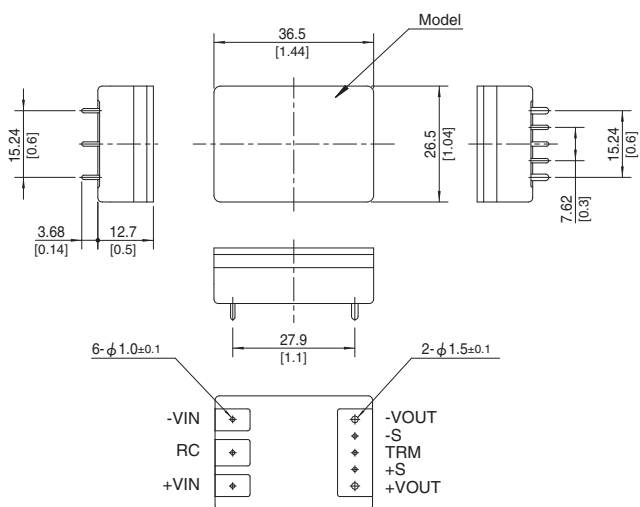

5. 5 pins type (option L5)

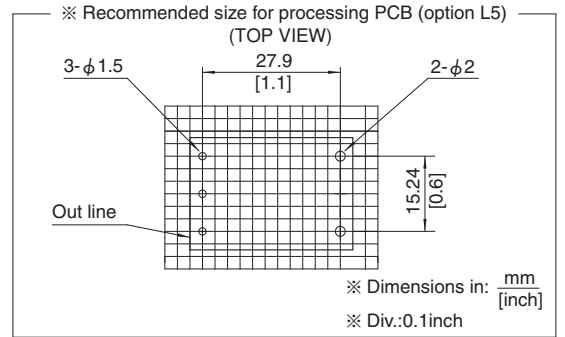
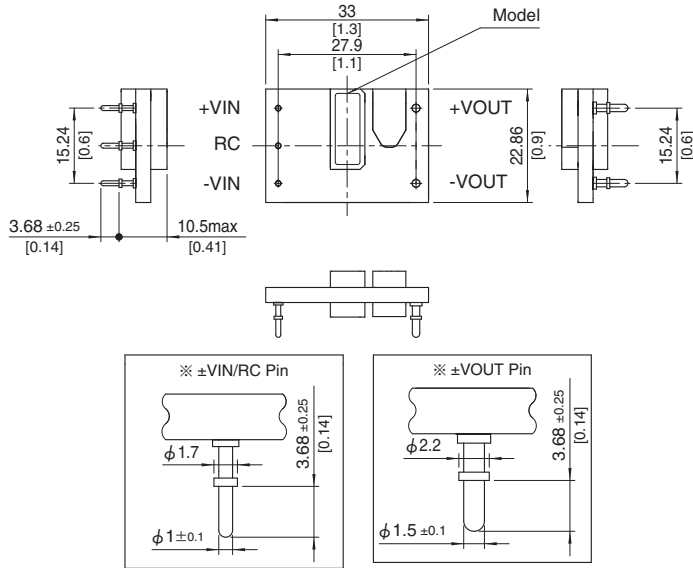

CHS200

CH S 200 48 05 -□

① ② ③ ④ ⑤ ⑥

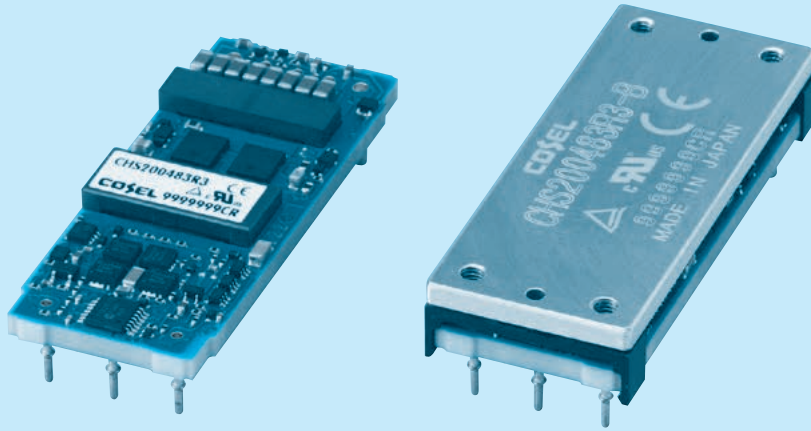

- ① Series name
- ② Single output
- ③ Output power
48:DC36-76V
- ④ Input voltage
48:DC36-76V
- ⑤ Output voltage
3R3:3.3V
05:5.0V
12:12V
- ⑥ Optional
R :with Remote ON/OFF
Positive logic control
U :Shut down in protection
circuit working
B :BasePlate option with
Mounting hole M3
L2:Pin length 5.3mm
L5:5pins option
(+S,-S,TRM less)

MODEL	CHS200483R3	CHS2004805	CHS2004812
MAX OUTPUT WATTAGE[W]	165.0	200.0	192.0
DC OUTPUT	3.3V 50A	5.0V 40A	12V 16A

SPECIFICATIONS

	MODEL	CHS200483R3	CHS2004805	CHS2004812	
INPUT	VOLTAGE[V]	DC36 - 76			
	CURRENT[A]	*1 3.70typ	4.43typ	4.26typ	
	EFFICIENCY[%]	*1 93typ	94typ	94typ	
OUTPUT	VOLTAGE[V]	3.3	5	12	
	CURRENT[A]	50	40	16	
	LINE REGULATION[mV]	10max			
	LOAD REGULATION[mV]	10max			
	RIPPLE	[mVrms] *2	30max	30max	50max
		[mVp-p] *2	80max	100max	150max
	RIPPLE NOISE[mVp-p]	*2 120max	150max	180max	
	TEMPERATURE REGULATION[mV]	66max	100max	240max	
	DRIFT[mV]	*3 16max	20max	40max	
	START-UP TIME[ms]	200max (DCIN 48V, Io=100%)			
OUTPUT VOLTAGE ADJUSTMENT RANGE	Fixed (TRM pin open), adjustable by external resistor				
ADJUSTMENT RANGE	-10% / +15%	-10% / +20%	-10% / +10%		
OUTPUT VOLTAGE SETTING	± 1.6%				
PROTECTION CIRCUIT AND OTHERS	OVERCURRENT PROTECTION	Works over 105% of rating (Auto restart)			
	OVERVOLTAGE PROTECTION	120% - 140% (Auto restart)	125% - 145% (Auto restart)	115% - 135% (Auto restart)	
	REMOTE SENSING	Provided			
	REMOTE ON/OFF	Provided (Negative logic L:ON, H:OFF)			
ISOLATION	INPUT-OUTPUT	DC2,250V or AC1,000V 1minute, Cutoff current = 10mA, DC500V 50MΩ min (20±15°C)			
	INPUT-BASEPLATE	*5 DC2,250V or AC1,000V 1minute, Cutoff current = 10mA, DC500V 50MΩ min (20±15°C)			
	OUTPUT-BASEPLATE	*5 AC500V 1minute, Cutoff current = 100mA, DC500V 50MΩ min (20±15°C)			
ENVIRONMENT	OPERATING TEMP.,HUMID.AND ALTITUDE	-40 to +85°C, 20 - 95%RH (Non condensing) (Refer to "Derating"), 3,000m (10,000feet) max			
	STORAGE TEMP.,HUMID.AND ALTITUDE	-40 to +100°C, 20 - 95%RH (Non condensing), 9,000m (30,000feet) max			
	VIBRATION	10 - 55Hz, 49.0m/s ² (5G), 3minutes period, 60minutes each along X, Y and Z axis			
	IMPACT	196.1m/s ² (20G), 11ms, once each along X, Y and Z axis			
SAFETY	AGENCY APPROVALS	UL60950-1, C-UL (CSA60950-1), EN62368-1			
OTHERS	CASE SIZE/WEIGHT	57.9 × 10.5 × 22.76mm [2.28 × 0.41 × 0.9 inches] (W × H × D) / 30g max			
	COOLING METHOD	58.4 × 12.7 × 23.26mm [2.3 × 0.5 × 0.92 inches] (W × H × D) / 45g max *5			
	COOLING METHOD	Convection / Forced air / Conduction			

*1 At rated input(DC48V) and rated load. Ta=25°C, 2m/s.

*2 Ripple and ripple noise is measured by using measuring board with ceramic capacitor 22 μF.

*3 Drift is the change in DC output for an eight hour period after a half-hour warm-up at 25°C, with the input voltage held constant at the rated input/output.

*4 Refer to the instruction manual for input voltage derating.

*5 BasePlate Option.

External view

1. DIP

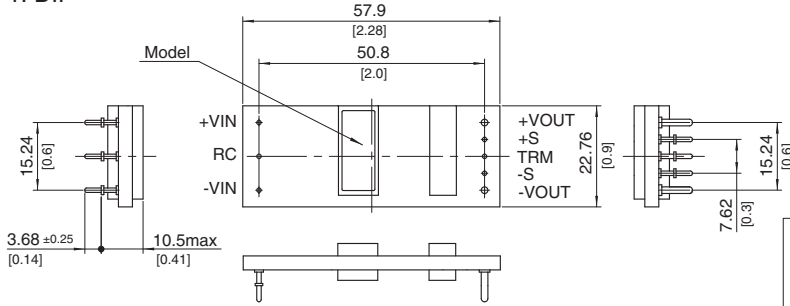

※ Tolerance : ±0.5 [±0.02]
 ※ Dimensions in mm, []=inches

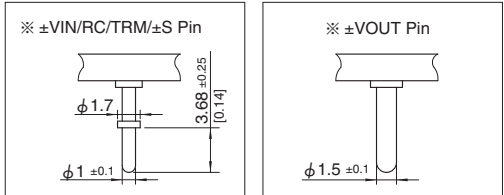

2. BasePlate (optionB)

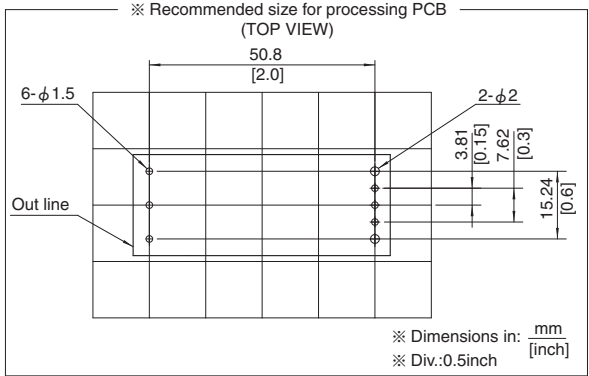
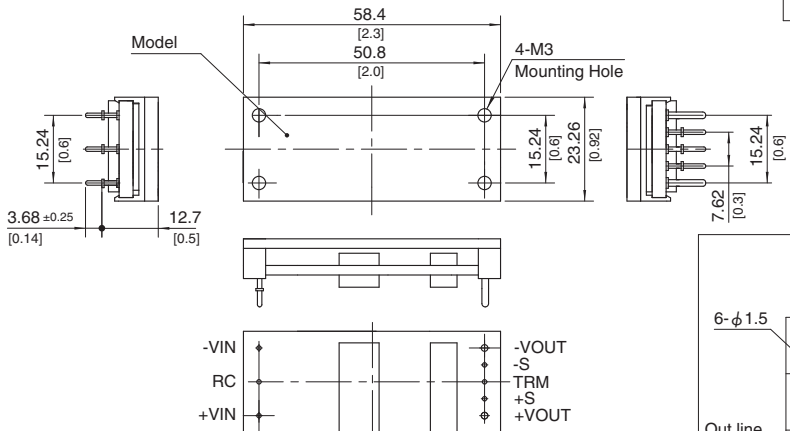

3. 5pins type (option L5)

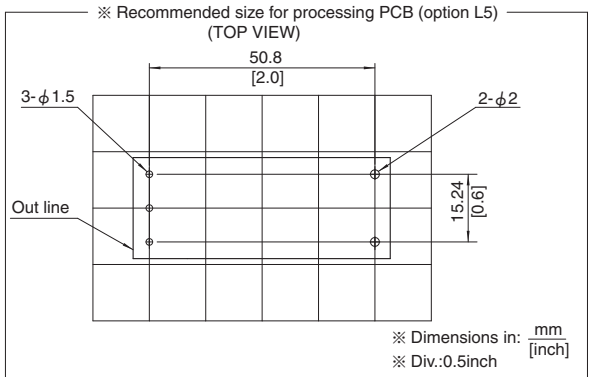
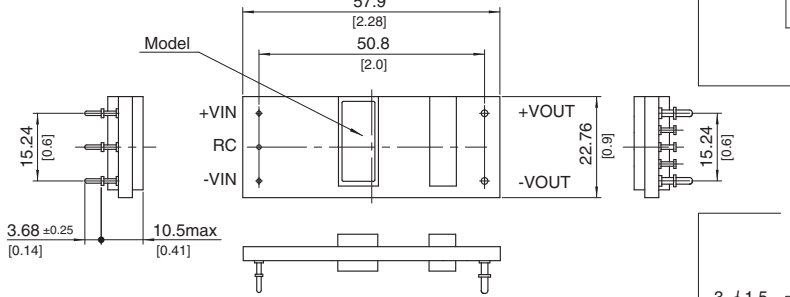

CHS300

CH S 300 48 10 - □

① ② ③ ④ ⑤ ⑥



RoHS

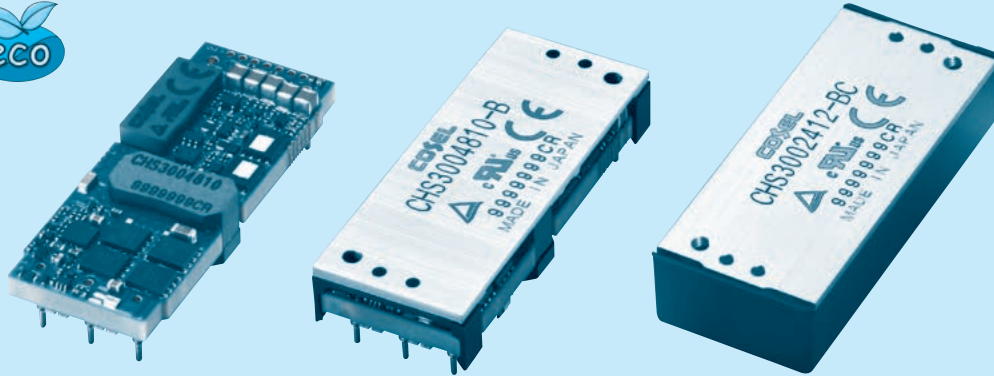

- ① Series name
- ② Single output
- ③ Output power
- ④ Input voltage
24:DC18 - 36V
48:DC36 - 76V
- ⑤ Output voltage
05:5V
10:10V
12:12V
12H:12V (High efficiency type)
15:15V
24:24V
28:28V
32:32V
48:48V
- ⑥ Optional
R :with Remote ON/OFF
Positive logic control
U :Shut down in protection
circuit working
B :Baseplate option with
mounting hole M3
BC:Baseplate and case option
with mounting hole M3
(only CHS30024)
L2:Pin length 5.3mm
L5:5pins option
(+S,-S,TRM less)
I :with the PMBus interface
(only CHS3004810/4812)

MODEL	CHS3002405	CHS3002412	CHS3002415	CHS3002424	CHS3002428	CHS3002432	CHS3002448
MAX OUTPUT WATTAGE[W]	200.0	200.4	202.5	252.0	252.0	252.8	254.4
DC OUTPUT	5V 40A	12V 16.7A	15V 13.5A	24V 10.5A	28V 9A	32V 7.9A	48V 5.3A

SPECIFICATIONS

	MODEL	CHS3002405	CHS3002412	CHS3002415	CHS3002424	CHS3002428	CHS3002432	CHS3002448	
INPUT	VOLTAGE[V]	DC18 - 36							
	CURRENT[A]	*1 8.91typ	9.08typ	9.02typ	11.17typ	11.17typ	11.21typ	11.34typ	
	EFFICIENCY[%]	*1 93.5typ	92.0typ	93.5typ	94.0typ	94.0typ	94.0typ	93.5typ	
	VOLTAGE[V]	5	12	15	24	28	32	48	
OUTPUT	CURRENT[A]	40	16.7	13.5	10.5	9	7.9	5.3	
	LINE REGULATION[mV]	10max	24max	30max	48max	56max	64max	96max	
	LOAD REGULATION[mV]	10max	24max	30max	48max	56max	64max	96max	
	RIPPLE	[mVrms]	*2 40max	50max	100max	90max	90max	90max	110max
		[mVp-p]	*2 120max	150max	280max	250max	250max	250max	300max
	RIPPLE NOISE[mVp-p]	*2 150max	180max	300max	280max	280max	280max	350max	
	TEMPERATURE REGULATION[mV]	120max	240max	300max	480max	560max	640max	960max	
	DRIFT[mV]	*3 20max	40max	50max	80max	90max	120max	180max	
	START-UP TIME[ms]	50max (DCIN 24V, Io=100%)							
	OUTPUT VOLTAGE ADJUSTMENT RANGE	*4 Fixed (TRM pin open), adjustable by external resistor -20% / +20% -20% / +10% -20% / +5% -10% / +10% -10% / +10% -10% / +10% -10% / +10%							
	OUTPUT VOLTAGE SETTING	*1 ±1.6%							
	PROTECTION CIRCUIT AND OTHERS	OVERCURRENT PROTECTION	Works over 105% of rating (Auto restart)						
OVERVOLTAGE PROTECTION		125% - 145% (Auto restart)	115% - 135% (Auto restart)	110% - 130% (Auto restart)	115% - 135% (Auto restart)	115% - 135% (Auto restart)	115% - 135% (Auto restart)	115% - 135% (Auto restart)	
REMOTE SENSING		Provided							
REMOTE ON/OFF		Provided (Negative Logic L : ON, H :OFF)							

MODEL	CHS3004810	CHS3004812	CHS3004812H	CHS3004815	CHS3004824	CHS3004828	CHS3004832	CHS3004848
MAX OUTPUT WATTAGE[W]	300.0	300.0	300.0	300.0	300.0	302.8	300.8	302.4
DC OUTPUT	10V 30A	12V 25A	12V 25A	15V 20A	24V 12.5A	28V 10.8A	32V 9.4A	48V 6.3A

SPECIFICATIONS

	MODEL	CHS3004810	CHS3004812	CHS3004812H	CHS3004815	CHS3004824	CHS3004828	CHS3004832	CHS3004848	
INPUT	VOLTAGE[V]	DC36 - 76								
	CURRENT[A]	*1 6.61typ	6.61typ	6.55typ	6.61typ	6.61typ	6.67typ	6.63typ	6.70typ	
	EFFICIENCY[%]	*1 94.5typ	94.5typ	95.5typ	94.5typ	94.5typ	94.5typ	94.5typ	94.0typ	
	VOLTAGE[V]	10	12	12	15	24	28	32	48	
OUTPUT	CURRENT[A]	30	25	25	20	12.5	10.8	9.4	6.3	
	LINE REGULATION[mV]	*6 20max	24max	24max	30max	48max	56max	64max	96max	
	LOAD REGULATION[mV]	*6 20max	24max	24max	30max	48max	56max	64max	96max	
	RIPPLE	[mVrms]	*2 40max	50max	50max	70max	90max	90max	90max	130max
		[mVp-p]	*2 120max	150max	150max	180max	250max	250max	250max	350max
	RIPPLE NOISE[mVp-p]	*2 150max	180max	180max	200max	280max	280max	280max	380max	
	TEMPERATURE REGULATION[mV]	200max	240max	240max	300max	480max	560max	640max	960max	
	DRIFT[mV]	*3 30max	40max	40max	50max	80max	90max	120max	180max	
	START-UP TIME[ms]	50max (DCIN 48V, Io=100%)								
	OUTPUT VOLTAGE ADJUSTMENT RANGE	*4 Fixed (TRM pin open), adjustable by external resistor -10% / +10% -10% / +10% -10% / +10% -10% / +10% -10% / +10% -10% / +10% -10% / +10% -20% / +15%								
	OUTPUT VOLTAGE SETTING	*1 ±1.6%								
	PROTECTION CIRCUIT AND OTHERS	OVERCURRENT PROTECTION	Works over 105% of rating (Auto restart)							
OVERVOLTAGE PROTECTION		115% - 135% (Auto restart)	115% - 135% (Auto restart)	115% - 135% (Auto restart)	115% - 135% (Auto restart)	115% - 135% (Auto restart)	115% - 135% (Auto restart)	115% - 135% (Auto restart)	120% - 140% (Auto restart)	
REMOTE SENSING		Provided								
REMOTE ON/OFF		Provided (Negative Logic L : ON, H :OFF)								

GENERAL SPECIFICATIONS

ISOLATION	INPUT-OUTPUT	DC2,250V or AC1,000V 1minute, Cutoff current = 10mA, DC500V 50MΩ min (20±15°C)
	INPUT-BASEPLATE *5,*7	DC2,250V or AC1,000V 1minute, Cutoff current = 10mA, DC500V 50MΩ min (20±15°C)
	OUTPUT-BASEPLATE *5,*7	AC500V 1minute, Cutoff current = 100mA, DC500V 50MΩ min (20±15°C)
ENVIRONMENT	OPERATING TEMP.,HUMID.AND ALTITUDE	-40 to +85°C, 20 - 95%RH (Non condensing) (Refer to “Derating”), 5,000m (16,000 feet) max
	STORAGE TEMP.,HUMID.AND ALTITUDE	-40 to +100°C, 20 - 95%RH (Non condensing), 9,000m (30,000 feet) max
	VIBRATION	10 - 55Hz, 49.0m/s ² (5G), 3minutes period, 60minutes each along X, Y and Z axis
	IMPACT	196.1m/s ² (20G), 11ms, once each along X, Y and Z axis
SAFETY	AGENCY APPROVALS	UL60950-1, C-UL (CSA60950-1), EN62368-1
OTHERS	CASE SIZE/WEIGHT	58.4 × 11.0 × 22.86mm [2.3 × 0.43 × 0.9 inches] (W × H × D) / 38g max
		58.9 × 12.7 × 23.26mm [2.32 × 0.5 × 0.92 inches] (W × H × D) / 50g max *5
		61.1 × 14.3 × 26.1 [2.41 × 0.56 × 1.03inches] (W × H × D) / 57g max *7
	COOLING METHOD	Convection / Forced air / Conduction

*1 At rated input (DC24V, DC48V) and rated load. Ta=25°C, 2m/s.

*2 Ripple and ripple noise is measured by using measuring board with ceramic capacitor 0.1 μF or 22 μF. (Refer to instruction manual for wiring output pin)

*3 Drift is the change in DC output for an eight hour period after a half-hour warm-up at 25°C, with the input voltage held constant at the rated input/output.

*4 Refer to the instruction manual for input voltage derating.

*5 BasePlate Option.

*6 At input voltage DC36 - 76V (CHS3004810, CHS3004812), DC40 - 76V (CHS3004812H).

*7 Baseplate and case option.

External view

1. DIP

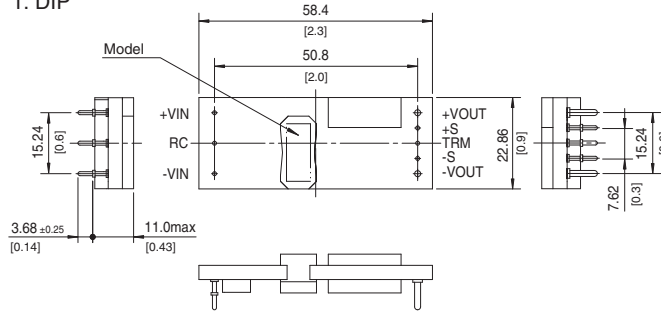

※ Tolerance: ±0.5 [±0.02]
 ※ Dimensions in mm, []=inches

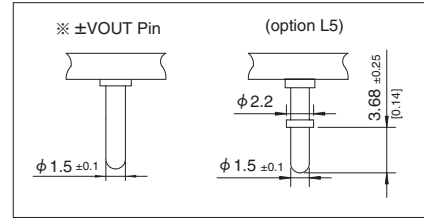

2. BasePlate (optionB)

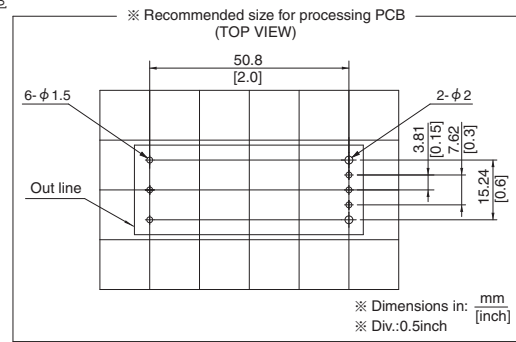
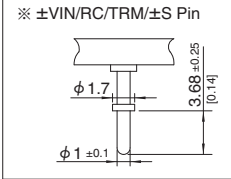
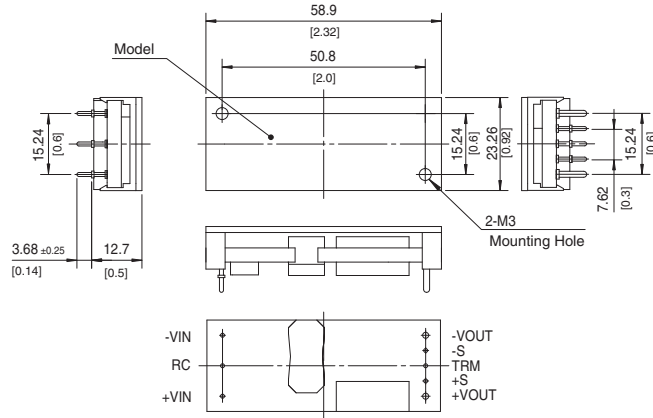

3. Baseplate and case (option BC)

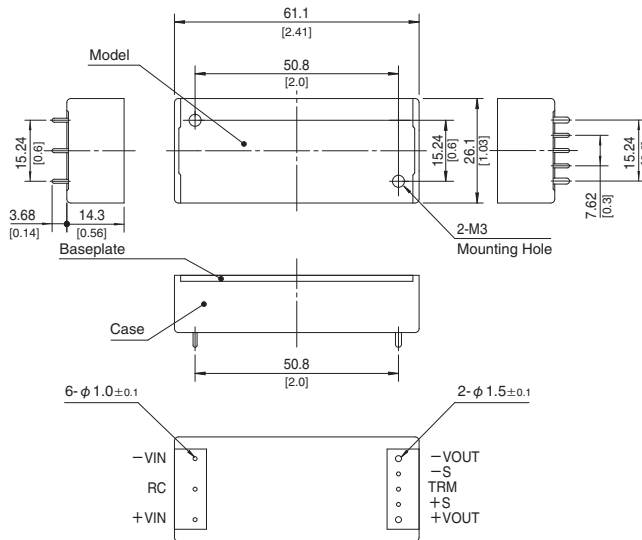

4. 5pins type (option L5)

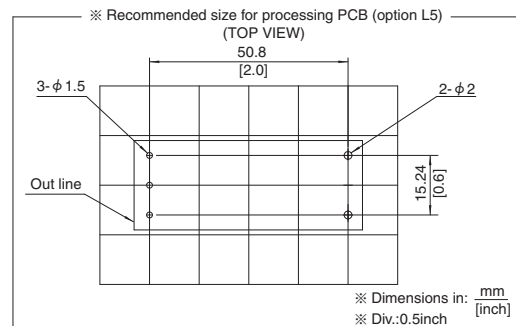
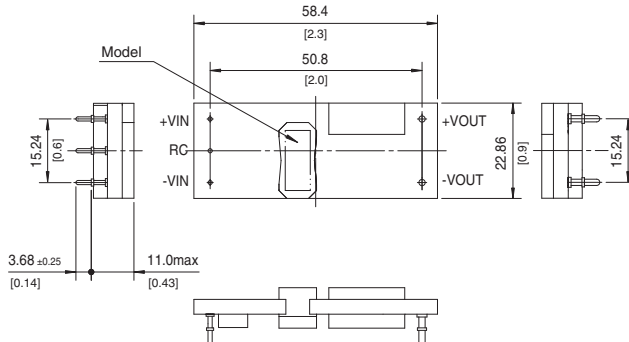

* Please contact us about external view of the PMBus interface (option I).

CHS380

CH S 380 48 12 - □

① ② ③ ④ ⑤ ⑥

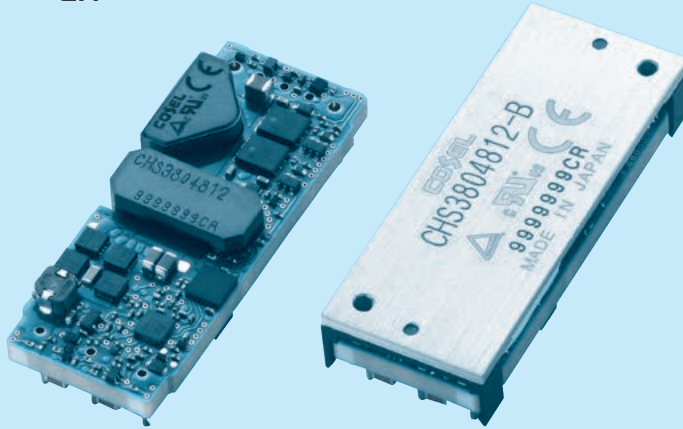

- ① Series name
- ② Single output
- ③ Output power
- ④ Input voltage
48:DC36 - 76V
- ⑤ Output voltage
10:10V
12:12V
12H:12V(High efficiency type)
- ⑥ Optional
R : with Remote ON/OFF
Positive logic control
U : Shut down in protection
circuit working
B : BasePlate option with
Mounting hole M3
L2: Pin length 5.3mm
L5: 5pins type (+S,-S,TRM
less)

MODEL	CHS3804810	CHS3804812	CHS3804812H
MAX OUTPUT WATTAGE[W]	380.0	384.0	384.0
DC OUTPUT	10V 38A	12V 32A	12V 32A

SPECIFICATIONS

	MODEL	CHS3804810	CHS3804812	CHS3804812H	
INPUT	VOLTAGE[V]	DC36 - 76			
	CURRENT[A]	*1 8.42typ	8.47typ	8.42typ	
	EFFICIENCY[%]	*1 94.0typ	94.5typ	95.0typ	
OUTPUT	VOLTAGE[V]	10	12	12	
	CURRENT[A]	38	32	32	
	LINE REGULATION[mV]	*6 20max	24max	24max	
	LOAD REGULATION[mV]	*6 20max	24max	24max	
	RIPPLE	[mVrms]	*2 40max	50max	60max
		[mVp-p]	*2 120max	150max	180max
	RIPPLE NOISE[mVp-p]	*2 150max	180max	200max	
	TEMPERATURE REGULATION[mV]	200max	240max	240max	
	DRIFT[mV]	*3 30max	40max	40max	
	START-UP TIME[ms]	50max (DCIN 48V, I _o =100%)			
OUTPUT VOLTAGE ADJUSTMENT RANGE	*4 Fixed (TRM pin open), adjustable by external resistor -10% / +10%				
OUTPUT VOLTAGE SETTING	*1 ±1.6%				
PROTECTION CIRCUIT AND OTHERS	OVERCURRENT PROTECTION	Works over 105% of rating (Auto restart)			
	OVERVOLTAGE PROTECTION	115% - 135% (Auto restart)			
	REMOTE SENSING	Provided			
	REMOTE ON/OFF	Provided (Negative Logic L : ON, H :OFF)			
ISOLATION	INPUT-OUTPUT	DC2,250V or AC1,000V 1minute, Cutoff current = 10mA, DC500V 50MΩ min (20±15°C)			
	INPUT-BASEPLATE	*5 DC2,250V or AC1,000V 1minute, Cutoff current = 10mA, DC500V 50MΩ min (20±15°C)			
	OUTPUT-BASEPLATE	*5 AC500V 1minute, Cutoff current = 100mA, DC500V 50MΩ min (20±15°C)			
ENVIRONMENT	OPERATING TEMP.,HUMID.AND ALTITUDE	-40 to +85°C, 20 - 95%RH (Non condensing) (Refer to "Derating"), 5,000m (16,000 feet) max			
	STORAGE TEMP.,HUMID.AND ALTITUDE	-40 to +100°C, 20 - 95%RH (Non condensing), 9,000m (30,000 feet) max			
	VIBRATION	10 - 55Hz, 49.0m/s ² (5G), 3minutes period, 60minutes each along X, Y and Z axis			
	IMPACT	196.1m/s ² (20G), 11ms, once each along X, Y and Z axis			
SAFETY	AGENCY APPROVALS	UL60950-1, C-UL (CSA60950-1), EN62368-1			
OTHERS	CASE SIZE/WEIGHT	58.4 × 11.0 × 22.86mm [2.3 × 0.43 × 0.9 inches] (W × H × D) / 38g max			
	COOLING METHOD	58.9 × 12.7 × 23.26mm [2.32 × 0.5 × 0.92 inches] (W × H × D) / 50g max *5			
		Convection / Forced air / Conduction			

*1 At rated input (DC48V) and rated load. Ta=25°C, 2m/s.
 *2 Ripple and ripple noise is measured by using measuring board with ceramic capacitor 22 μF.
 *3 Drift is the change in DC output for an eight hour period after a half-hour warm-up at 25°C, with the input voltage held constant at the rated input/output.
 *4 Refer to the instruction manual for input voltage derating.
 *5 BasePlate Option.
 *6 At input voltage DC36-76V(CHS3804810, CHS3804812), DC40-76V(CHS3804812H).

External view

1. DIP

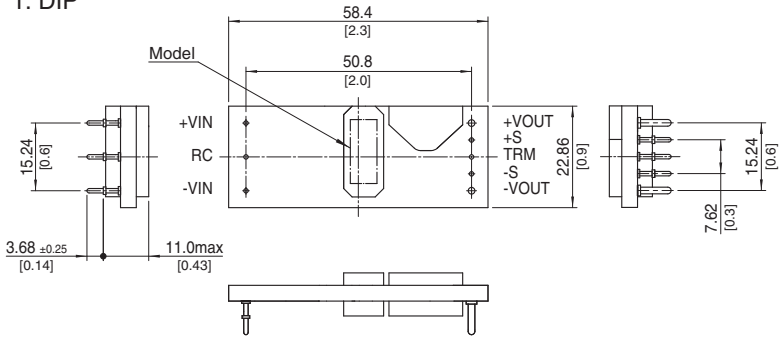

※ Tolerance: ±0.5 [±0.02]
 ※ Dimensions in mm, []=inches

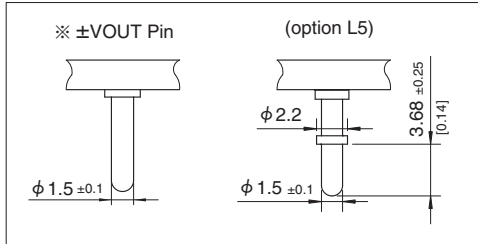

2. BasePlate (optionB)

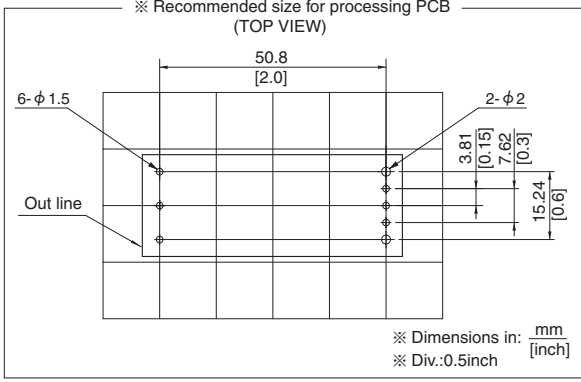
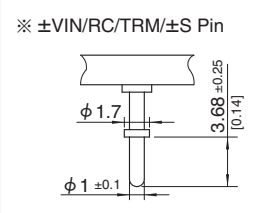
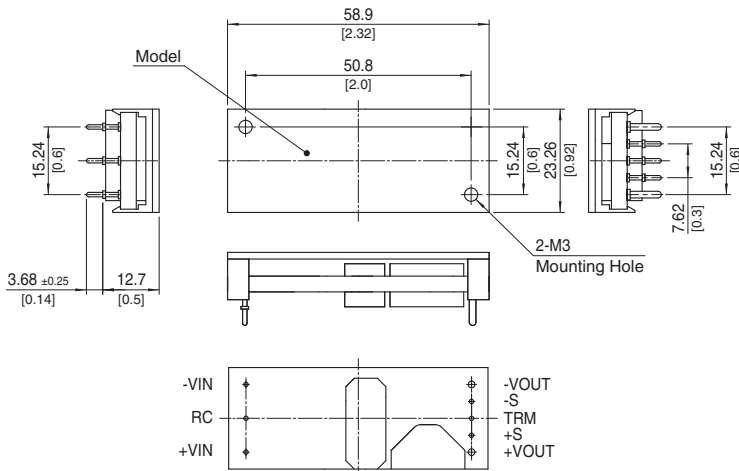

3. Parallel operation (option P)
5pins type (option L5)

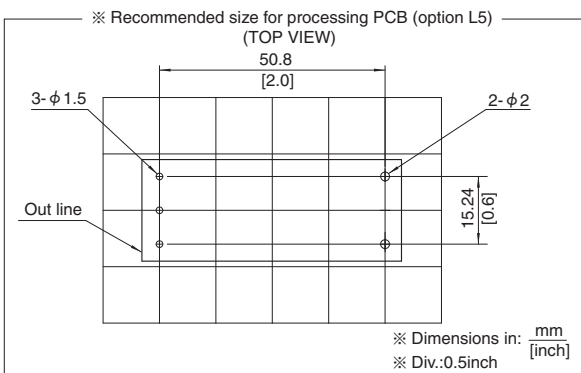
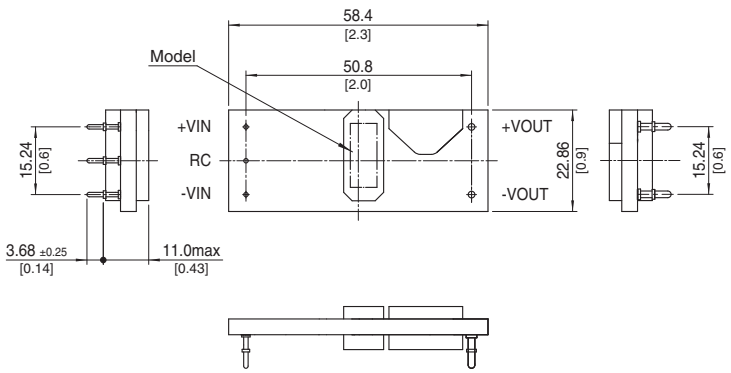

CHS400

CH S 400 48 12 - □

① ② ③ ④ ⑤ ⑥



RoHS

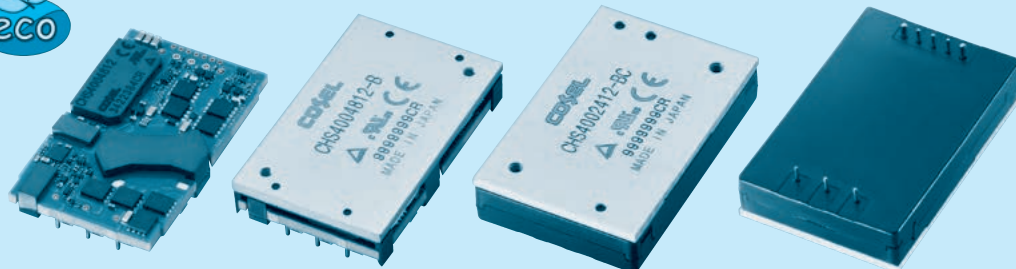

- ① Series name
- ② Single output
- ③ Output power
- ④ Input voltage
24:DC18 - 36V
48:DC36 - 76V
- ⑤ Output voltage
10:10V
12:12V
12H:12V(High efficiency type)
15:15V
24:24V
28:28V
32:32V
48:48V
- ⑥ Optional
R :with Remote ON/OFF
Positive logic control
U :Shut down in protection
circuit working
B :BasePlate option with
Mounting hole M3
BC:Baseplate and case
option with Mounting hole
M3 (only CHS40024)
P :Parallel operation (5Pins
:without +S,-S and TRM)
(only CHS4004810/12/12H)
L2:Pin length 5.3mm
L5:5pins type (+S,-S,TRM
less)
I :with the PMBus interface
(Only CHS4004812)

MODEL	CHS4002412	CHS4002415	CHS4002424	CHS4002428	CHS4002432	CHS4002448
MAX OUTPUT WATTAGE[W]	318.0	397.5	348.0	350.0	352.0	302.4
DC OUTPUT	12V 26.5A	15V 26.5A	24V 14.5A	28V 12.5A	32V 11A	48V 6.3A

SPECIFICATIONS

	MODEL	CHS4002412	CHS4002415	CHS4002424	CHS4002428	CHS4002432	CHS4002448	
INPUT	VOLTAGE[V]	DC18 - 36						
	CURRENT[A]	*1 14.17typ	17.53typ	15.43typ	15.51typ	15.60typ	13.40typ	
	EFFICIENCY[%]	*1 93.5typ	94.5typ	94.0typ	94.0typ	94.0typ	94.0typ	
OUTPUT	VOLTAGE[V]	12	15	24	28	32	48	
	CURRENT[A]	26.5	26.5	14.5	12.5	11	6.3	
	LINE REGULATION[mV]	24max	30max	48max	56max	64max	96max	
	LOAD REGULATION[mV]	24max	30max	48max	56max	64max	96max	
	RIPPLE	[mVrms] *2	60max	60max	90max	90max	90max	110max
		[mVp-p] *2	180max	180max	250max	250max	250max	300max
	RIPPLE NOISE[mVp-p]	*2 200max	200max	280max	280max	280max	350max	
	TEMPERATURE REGULATION[mV]	240max	300max	480max	560max	640max	960max	
	DRIFT[mV]	*3 40max	50max	80max	90max	120max	180max	
	START-UP TIME[ms]	50max (DCIN 24V, Io=100%)						
OUTPUT VOLTAGE ADJUSTMENT RANGE[V]	*4	Fixed (TRM pin open), adjustable by external resistor						
		-20% / +10%	-20% / +5%	-20% / +10%	-20% / +10%	-20% / +10%	-20% / +10%	
OUTPUT VOLTAGE SETTING[V]	*1	±1.6%	±1.6%	±1.6%	±1.6%	±1.6%	±1.6%	
PROTECTION CIRCUIT AND OTHERS	OVERCURRENT PROTECTION	Works over 105% of rating (Auto restart)						
	OVERVOLTAGE PROTECTION	115% - 135% (Auto restart)	110% - 130% (Auto restart)	115% - 135% (Auto restart)	115% - 135% (Auto restart)	115% - 135% (Auto restart)	115% - 135% (Auto restart)	
	REMOTE SENSING	Provided						
	REMOTE ON/OFF	Provided (Negative Logic L : ON, H :OFF)						

MODEL	CHS4004810	CHS4004812	CHS4004812H	CHS4004815	CHS4004824	CHS4004828	CHS4004832	CHS4004848
MAX OUTPUT WATTAGE[W]	400.0	396.0	396.0	397.5	396.0	392.0	400.0	403.2
DC OUTPUT	10V 40A	12V 33A	12V 33A	15V 26.5A	24V 16.5A	28V 14A	32V 12.5A	48V 8.4A

SPECIFICATIONS

	MODEL	CHS4004810	CHS4004812	CHS4004812H	CHS4004815	CHS4004824	CHS4004828	CHS4004832	CHS4004848	
INPUT	VOLTAGE[V]	DC36 - 76								
	CURRENT[A] *1	8.82typ	8.68typ	8.64typ	8.76typ	8.73typ	8.64typ	8.82typ	8.94typ	
	EFFICIENCY[%] *1	94.5typ	95typ	95.5typ	94.5typ	94.5typ	94.5typ	94.5typ	94.0typ	
OUTPUT	VOLTAGE[V]	10	12	12	15	24	28	32	48	
	CURRENT[A]	40	33	33	26.5	16.5	14	12.5	8.4	
	LINE REGULATION[mV] *8	20max	24max	24max	30max	48max	56max	64max	96max	
	LOAD REGULATION[mV] *7	20max	24max	24max	30max	48max	56max	64max	96max	
	RIPPLE	[mVrms] *2	60max	60max	60max	70max	100max	100max	100max	110max
		[mVp-p] *2	160max	180max	180max	200max	280max	280max	280max	300max
	RIPPLE NOISE[mVp-p] *2	180max	200max	200max	220max	300max	300max	300max	350max	
	TEMPERATURE REGULATION[mV]	200max	240max	240max	300max	480max	560max	640max	960max	
	DRIFT[mV] *3	30max	40max	40max	50max	80max	90max	120max	180max	
	START-UP TIME[ms]	50max (DCIN 48V, Io=100%)								
	OUTPUT VOLTAGE ADJUSTMENT RANGE[V] *4	Fixed (TRM pin open), adjustable by external resistor (N/A : parallel operation)								
	OUTPUT VOLTAGE SETTING[V] *1, *7	±1.6%	±1.6%	±1.6%	±1.6%	±1.6%	±1.6%	±1.6%	±1.6%	
	PROTECTION CIRCUIT AND OTHERS	OVERCURRENT PROTECTION	Works over 105% of rating (Auto restart)							
OVERVOLTAGE PROTECTION		115% - 135% (Auto restart)								
REMOTE SENSING		Provided (N/A : parallel operation)								
REMOTE ON/OFF		Provided (Negative Logic L : ON, H :OFF)								

GENERAL SPECIFICATIONS

ISOLATION	INPUT-OUTPUT	DC2,250V or AC1,000V 1minute, Cutoff current = 10mA, DC500V 50MΩ min (20±15°C)
	INPUT-BASEPLATE *5, *6	DC2,250V or AC1,000V 1minute, Cutoff current = 10mA, DC500V 50MΩ min (20±15°C)
	OUTPUT-BASEPLATE *5, *6	AC500V 1minute, Cutoff current = 100mA, DC500V 50MΩ min (20±15°C)
ENVIRONMENT	OPERATING TEMP., HUMID. AND ALTITUDE	-40 to +85°C, 20 - 95%RH (Non condensing) (Refer to "Derating"), 5,000m (16,000 feet) max
	STORAGE TEMP., HUMID. AND ALTITUDE	-40 to +100°C, 20 - 95%RH (Non condensing), 9,000m (30,000 feet) max
	VIBRATION	10 - 55Hz, 49.0m/s ² (5G), 3minutes period, 60minutes each along X, Y and Z axis
	IMPACT	196.1m/s ² (20G), 11ms, once each along X, Y and Z axis
SAFETY	AGENCY APPROVALS	UL60950-1, C-UL (CSA60950-1), EN62368-1
OTHERS	CASE SIZE/WEIGHT	58.4×9.5×36.8mm [2.3×0.37×1.45 inches] (W×H×D) / 60g max
		58.9×12.7×37.3mm [2.32×0.5×1.47 inches] (W×H×D) / 90g max *5
		61.6×12.7×40.3mm [2.43×0.5×1.59 inches] (W×H×D) / 90g max *6
	COOLING METHOD	Convection / Forced air / Conduction

*1 At rated input (DC24V, DC48V) and rated load. Ta=25°C, 2m/s.

*2 Ripple and ripple noise is measured by using measuring board with ceramic capacitor 0.1 μF or 22 μF. (Refer to instruction manual for wiring output pin)

*3 Drift is the change in DC output for an eight hour period after a half-hour warm-up at 25°C, with the input voltage held constant at the rated input/output.

*4 Refer to the instruction manual for input voltage derating.

*5 Baseplate Option.

*6 Baseplate and case option.

*7 Parallel operation Option is not included.

*8 At input voltage DC36-76V(CHS4004810, CHS4004812), DC40-76V(CHS4004812H).

External view

1. DIP

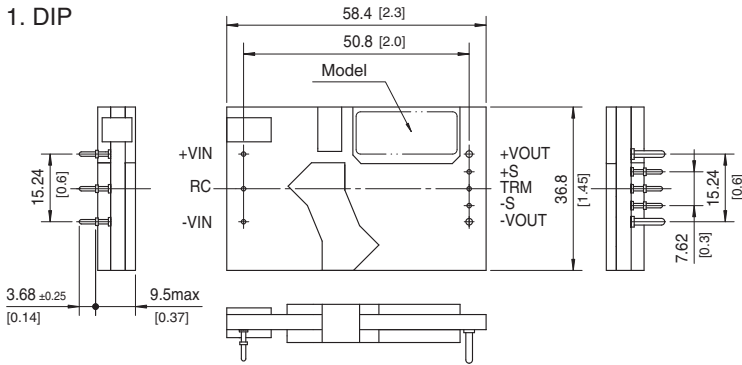

※ Tolerance: ±0.5 [±0.02]
 ※ Dimensions in mm, []=inches

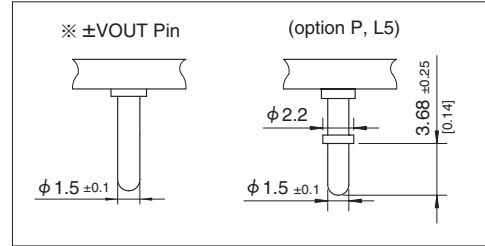

2. BasePlate (optionB)

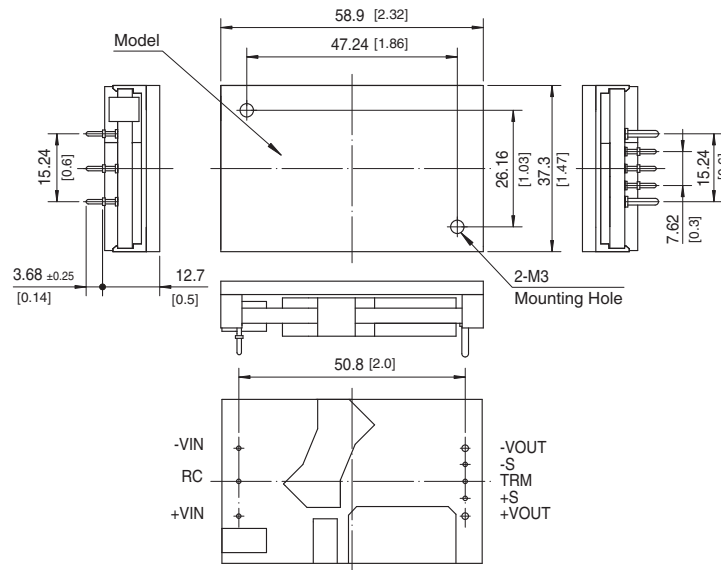

※ ±VIN/RC/TRM/±S Pin

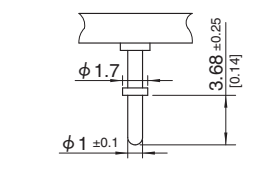

※ Recommended size for processing PCB (TOP VIEW)

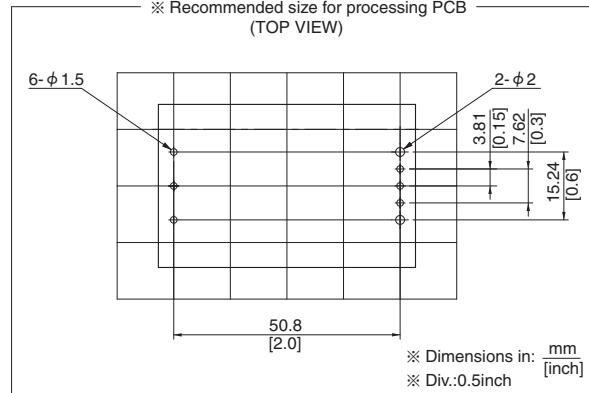

3. Baseplate and case (optionBC)

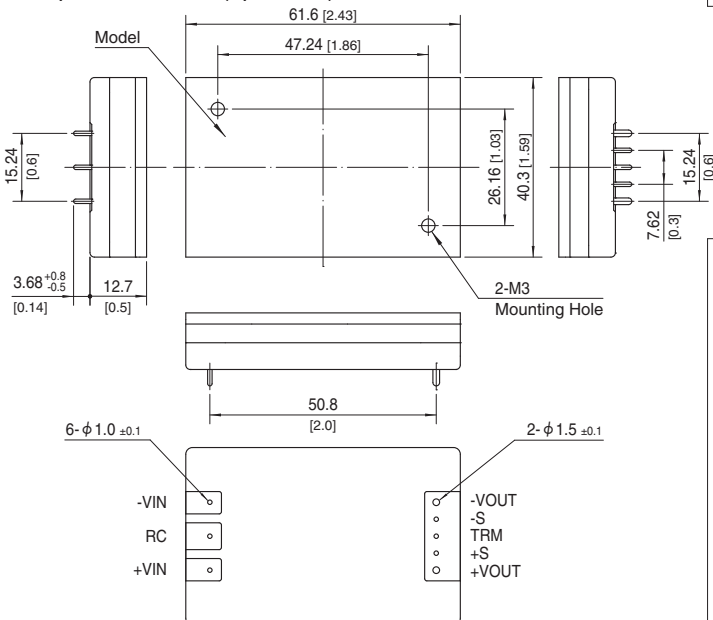

※ Recommended size for processing PCB (option BC) (TOP VIEW)

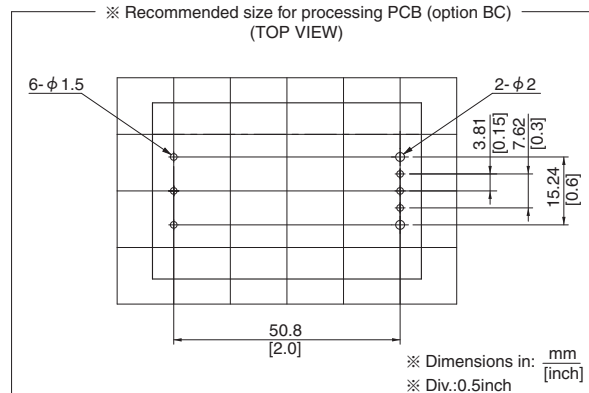

External view

4. Parallel operation (option P)
5pins type (option L5)

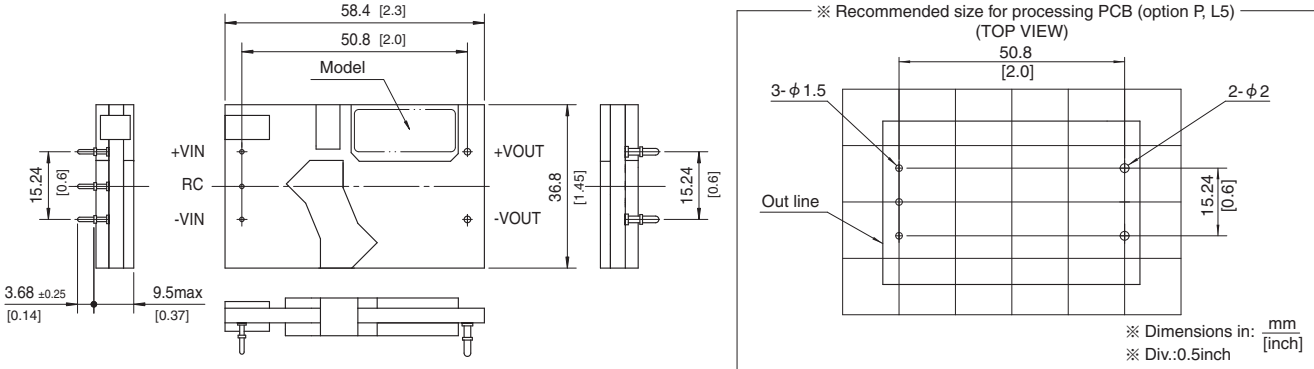

* Please contact us about external view of the PMBus interface (option I).

CHS500

CH S 500 48 12 - □

① ② ③ ④ ⑤ ⑥

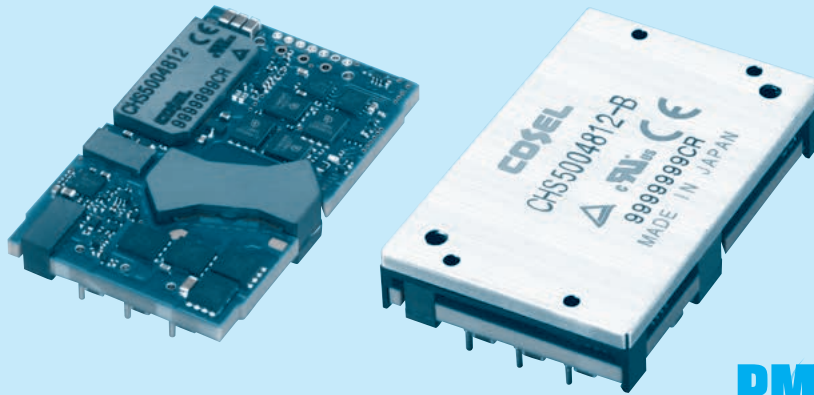

- ① Series name
- ② Single output
- ③ Output power
- ④ Input voltage
48:DC36 - 76V
- ⑤ Output voltage
12:12V
- ⑥ Optional
 - R :with Remote ON/OFF
Positive logic control
 - U :Shut down in protection
circuit working
 - B :BasePlate option with
Mounting hole M3
 - P :Parallel operation (5Pins
:without +S,-S and TRM)
 - L2:Pin length 5.3mm
 - L5:5pins type (+S,-S,TRM
less)
 - I :with the PMBus interface
(Only CHS5004812)

MODEL	CHS5004812
MAX OUTPUT WATTAGE[W]	504.0
DC OUTPUT	12V 42A

SPECIFICATIONS

	MODEL	CHS5004812	
INPUT	VOLTAGE[V]	DC36 - 76	
	CURRENT[A]	*1 11.06typ	
	EFFICIENCY[%]	*1 95typ	
OUTPUT	VOLTAGE[V]	12	
	CURRENT[A]	42	
	LINE REGULATION[mV]	24max	
	LOAD REGULATION[mV]	*6 24max	
	RIPPLE	[mVrms] *2	60max
		[mVp-p] *2	180max
	RIPPLE NOISE[mVp-p]	*2 200max	
	TEMPERATURE REGULATION[mV]	240max	
	DRIFT[mV]	*3 40max	
	START-UP TIME[ms]	50max (DCIN 48V, Io=100%)	
OUTPUT VOLTAGE ADJUSTMENT RANGE[V]	*4 Fixed (TRM pin open), adjustable by external resistor (N/A : parallel operation) -10% / +10%		
OUTPUT VOLTAGE SETTING[V]	*1 *5 ±1.6%		
PROTECTION CIRCUIT AND OTHERS	OVERCURRENT PROTECTION	Works over 105% of rating (Auto restart)	
	OVERVOLTAGE PROTECTION	115% - 135% (Auto restart)	
	REMOTE SENSING	Provided (N/A : parallel operation)	
	REMOTE ON/OFF	Provided (Negative Logic L : ON, H :OFF)	
ISOLATION	INPUT-OUTPUT	DC2,250V or AC1,000V 1minute, Cutoff current = 10mA, DC500V 50MΩ min (20±15°C)	
	INPUT-BASEPLATE	*5 DC2,250V or AC1,000V 1minute, Cutoff current = 10mA, DC500V 50MΩ min (20±15°C)	
	OUTPUT-BASEPLATE	*5 AC500V 1minute, Cutoff current = 100mA, DC500V 50MΩ min (20±15°C)	
ENVIRONMENT	OPERATING TEMP.,HUMID.AND ALTITUDE	-40 to +85°C, 20 - 95%RH (Non condensing) (Refer to "Derating"), 5,000m (16,000 feet) max	
	STORAGE TEMP.,HUMID.AND ALTITUDE	-40 to +100°C, 20 - 95%RH (Non condensing), 9,000m (30,000 feet) max	
	VIBRATION	10 - 55Hz, 49.0m/s ² (5G), 3minutes period, 60minutes each along X, Y and Z axis	
	IMPACT	196.1m/s ² (20G), 11ms, once each along X, Y and Z axis	
SAFETY	AGENCY APPROVALS	UL60950-1, C-UL (CSA60950-1), EN62368-1	
OTHERS	CASE SIZE/WEIGHT	58.4 × 9.5 × 36.8mm [2.3 × 0.37 × 1.45 inches] (W × H × D) / 60g max 58.9 × 12.7 × 37.3mm [2.32 × 0.5 × 1.47 inches] (W × H × D) / 90g max *5	
	COOLING METHOD	Convection / Forced air / Conduction	

*1 At rated input (DC48V) and rated load. Ta=25°C, 2m/s.
 *2 Ripple and ripple noise is measured by using measuring board with ceramic capacitor 22 μF.
 *3 Drift is the change in DC output for an eight hour period after a half-hour warm-up at 25°C, with the input voltage held constant at the rated input/output.
 *4 Refer to the instruction manual for input voltage derating.
 *5 BasePlate Option.
 *6 Parallel operation Option is not included.

External view

1. DIP

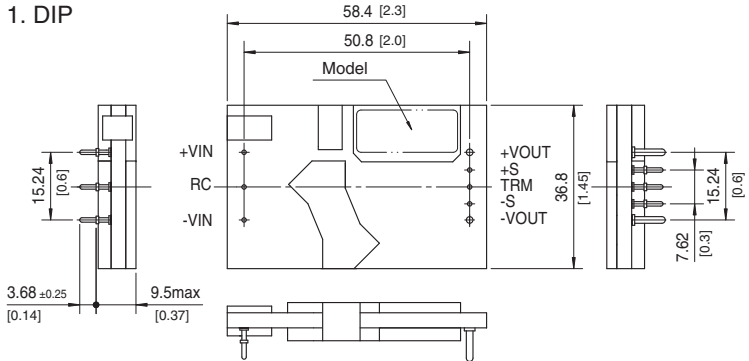

※ Tolerance: ±0.5 [±0.02]
 ※ Dimensions in mm, []=inches

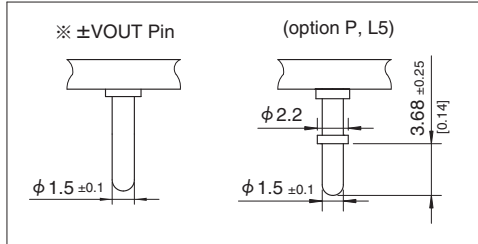

2. BasePlate (optionB)

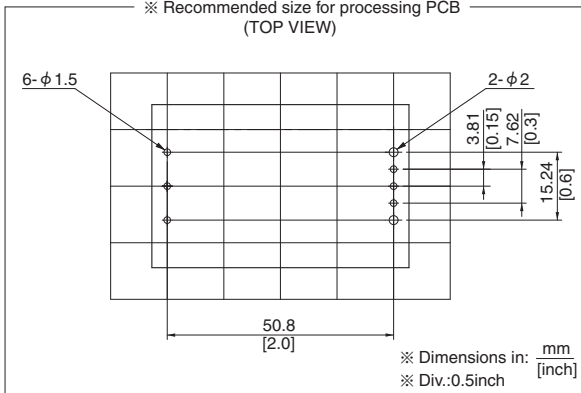
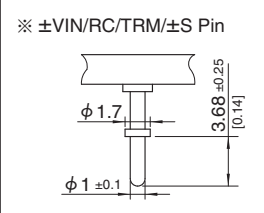
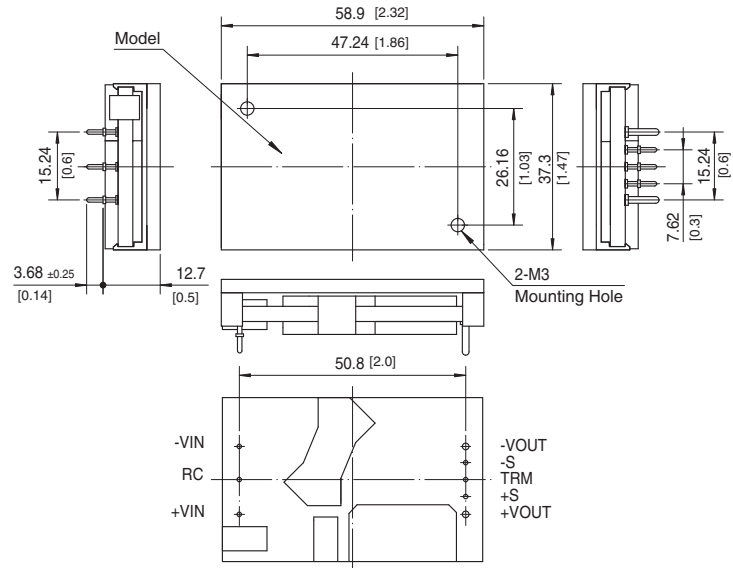

3. Parallel operation (option P)
5pins type (option L5)

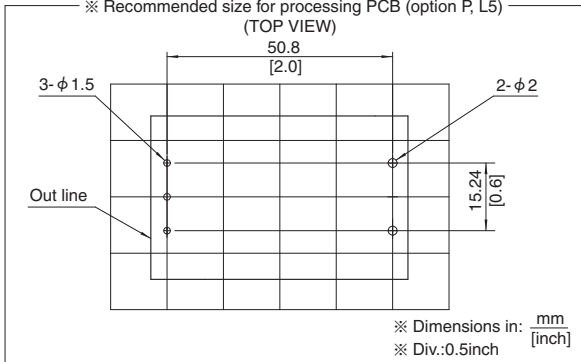
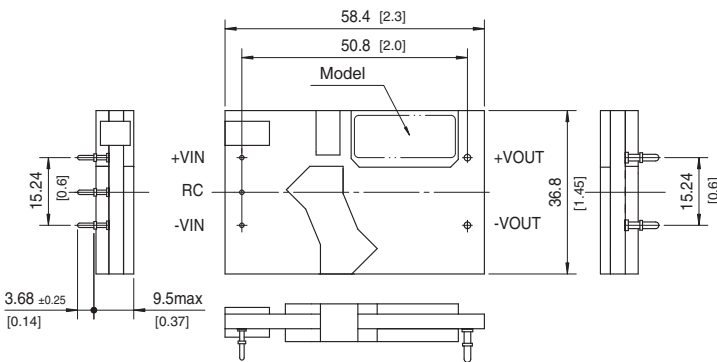

*Please contact us about external view of the PMBus interface (option I).

CHS700

CH S 700 48 12 - □

① ② ③ ④ ⑤ ⑥

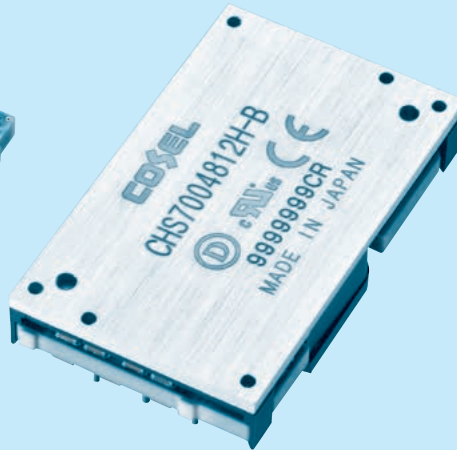
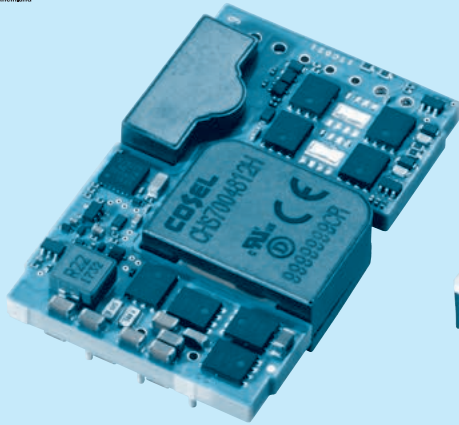

- ① Series name
- ② Single output
- ③ Output power
- ④ Input voltage
48:DC36 - 76V
- ⑤ Output voltage
12H:12V (High efficiency type)
- ⑥ Optional
R :with Remote ON/OFF
Positive logic control
U :Shut down in protection
circuit working
B :BasePlate option with
Mounting hole M3
L2:Pin length 5.3mm
L5:5pins type (Pin No. 4, 6,
7, 8, 10 less)
L7:7pins type (Pin No. 6, 7, 8
less)
L8:8pins type (Pin No. 4, 10
less)
*Refer to the "Pin Configuration"
for pin assign.

MODEL	CHS7004812H
MAX OUTPUT WATTAGE[W]	702.0
DC OUTPUT	12V 58.5A

SPECIFICATIONS

	MODEL	CHS7004812H	
INPUT	VOLTAGE[V]	DC36 - 76	
	CURRENT[A]	*1 15.3typ	
	EFFICIENCY[%]	*1 96typ	
OUTPUT	VOLTAGE[V]	12	
	CURRENT[A]	58.5	
	LINE REGULATION[mV]	*6 24max	
	LOAD REGULATION[mV]	*6 24max	
	RIPPLE	[mVrms]	*2 80max
		[mVp-p]	*2 240max
	RIPPLE NOISE[mVp-p]	*2 280max	
	TEMPERATURE REGULATION[mV]	240max	
	DRIFT[mV]	*3 40max	
	START-UP TIME[ms]	50max (DCIN 48V, Io=100%)	
OUTPUT VOLTAGE ADJUSTMENT RANGE[V]	*4 Fixed (TRM pin open), adjustable by external resistor -20% / +10%		
OUTPUT VOLTAGE SETTING[V]	*1 *6 ±1.6%		
PROTECTION CIRCUIT AND OTHERS	OVERCURRENT PROTECTION	Works over 105% of rating (Auto restart)	
	OVERVOLTAGE PROTECTION	115% - 135% (Auto restart)	
	REMOTE SENSING	Provided	
	REMOTE ON/OFF	Provided (Negative Logic L : ON, H : OFF)	
ISOLATION	INPUT-OUTPUT	DC2,250V or AC1,000V 1minute, Cutoff current = 10mA, DC500V 50MΩ min (20±15°C)	
	INPUT-BASEPLATE	*5 DC2,250V or AC1,000V 1minute, Cutoff current = 10mA, DC500V 50MΩ min (20±15°C)	
	OUTPUT-BASEPLATE	*5 AC500V 1minute, Cutoff current = 100mA, DC500V 50MΩ min (20±15°C)	
ENVIRONMENT	OPERATING TEMP.,HUMID.AND ALTITUDE	-40 to +85°C, 20 - 95%RH (Non condensing) (Refer to "Derating"), 5,000m (16,000 feet) max	
	STORAGE TEMP.,HUMID.AND ALTITUDE	-40 to +100°C, 20 - 95%RH (Non condensing), 9,000m (30,000 feet) max	
	VIBRATION	10-55Hz 49.0m/s ² (5G), 3minutes period, 60minutes each along X, Y and Z axis	
	IMPACT	196.1m/s ² (20G), 11ms, once each along X, Y and Z axis	
SAFETY	AGENCY APPROVALS	UL62368-1, C-UL (CSA62368-1), EN62368-1	
OTHERS	CASE SIZE/WEIGHT	58.4 X 10.5 X 36.8mm [2.3 X 0.41 X 1.45 inches] (W X H X D) / 72g max 58.9 X 12.7 X 37.3mm [2.32 X 0.5 X 1.47 inches] (W X H X D) / 100g max *5	
	COOLING METHOD	Convection / Forced air / Conduction	

*1 At rated input (DC48V) and rated load. Ta=25°C, 2m/s.
 *2 Ripple and ripple noise is measured by using measuring board with ceramic capacitor 22 μF
 *3 Drift is the change in DC output for an eight hour period after a half-hour warm-up at 25°C, with the input voltage held constant at the rated input/output.
 *4 Refer to the instruction manual for input voltage derating.
 *5 BasePlate Option.
 *6 At input voltage DC40-76V.

External view

1. DIP

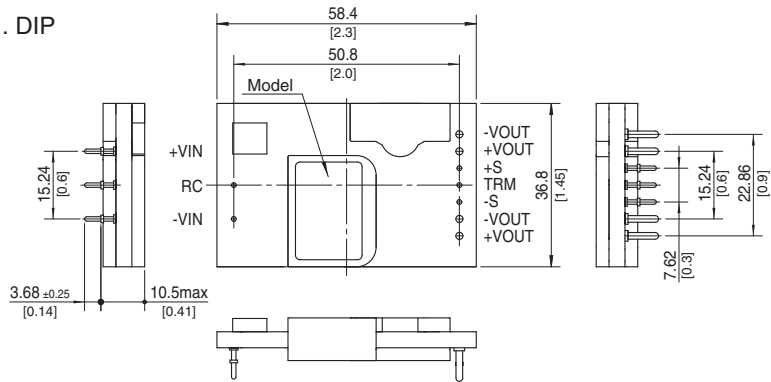

※ Tolerance:±0.5
※ Dimensions in mm, []=inches

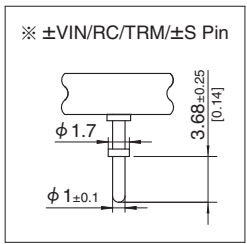
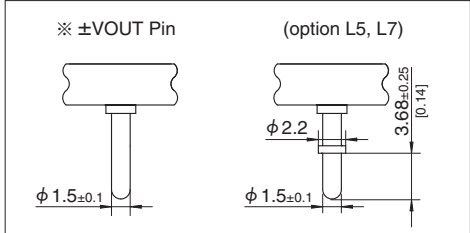

2. BasePlate (optionB)

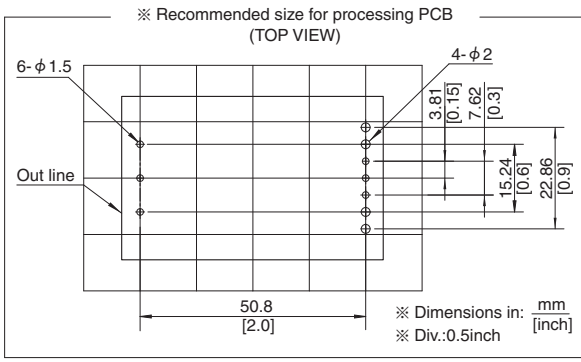
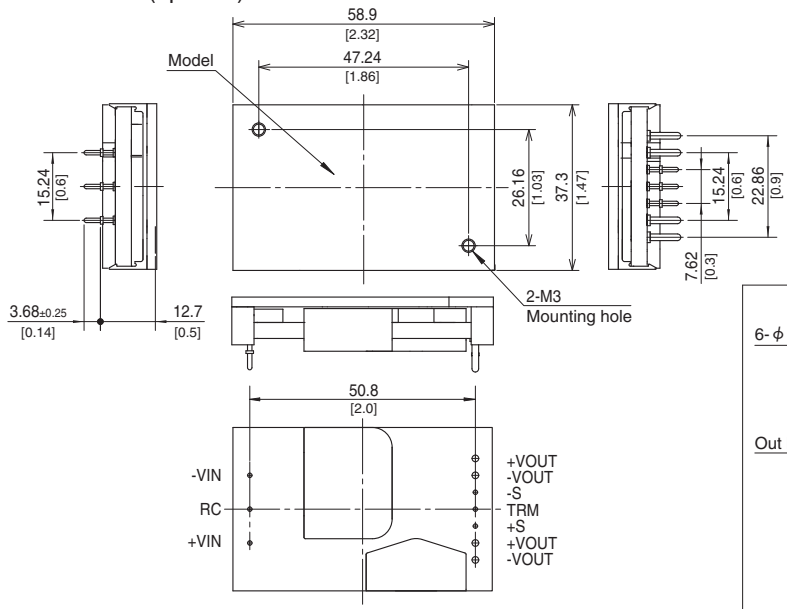

3. 5pins type (option L5)

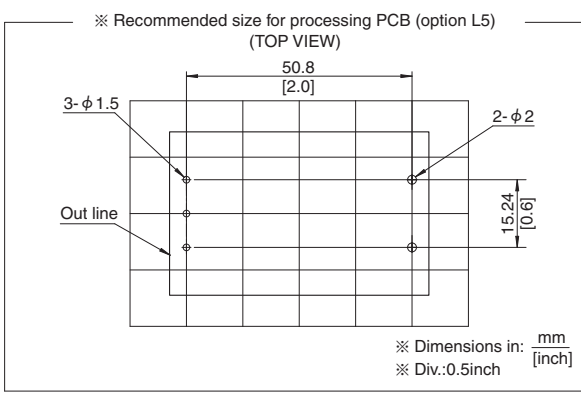
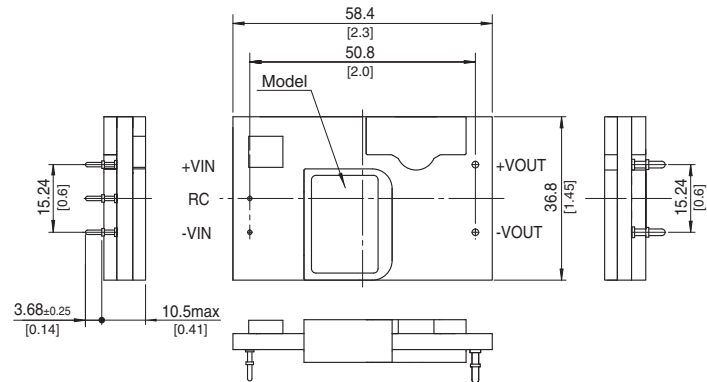

CHS

External view

4. 7pins type (option L7)

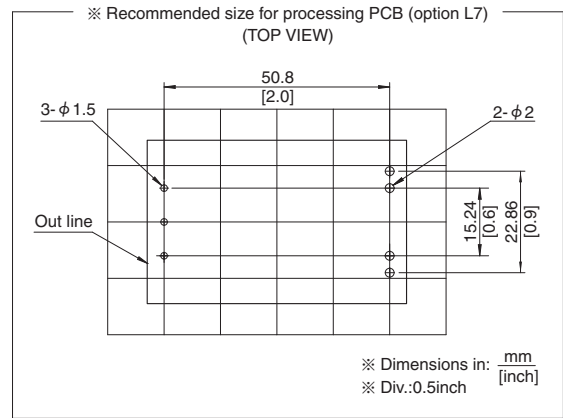
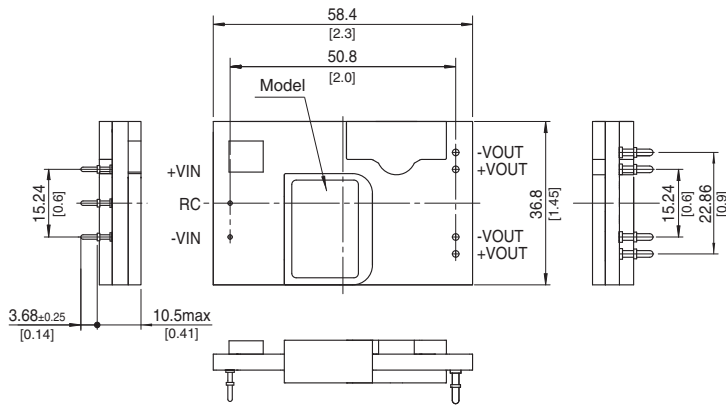

5. 8pins type (option L8)

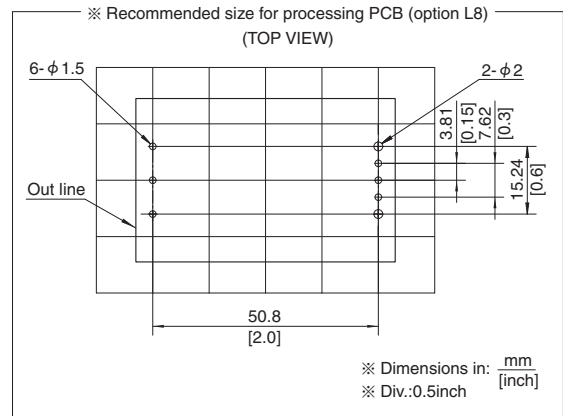
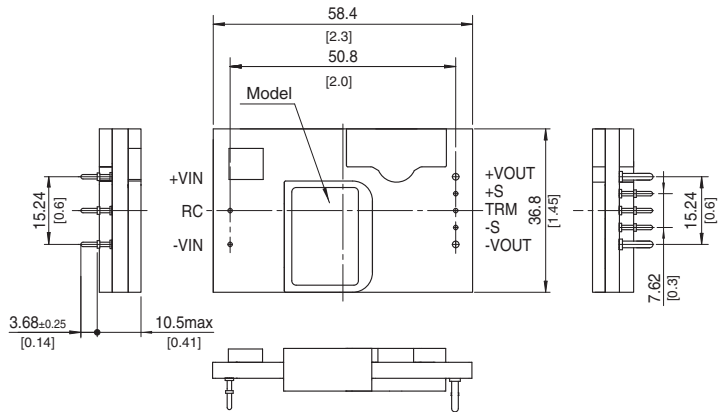

Pin Configuration

●CHS60

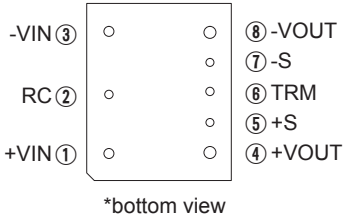

●CHS80

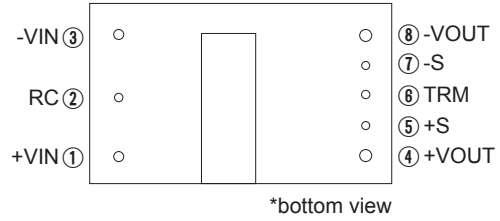

●CHS120

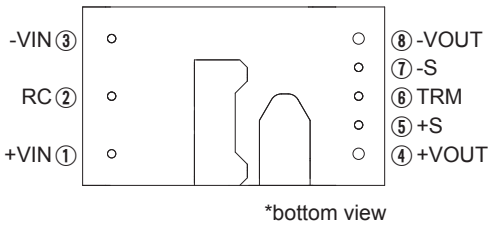

●CHS200

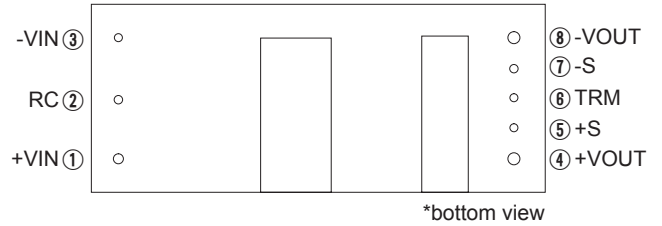

●CHS300

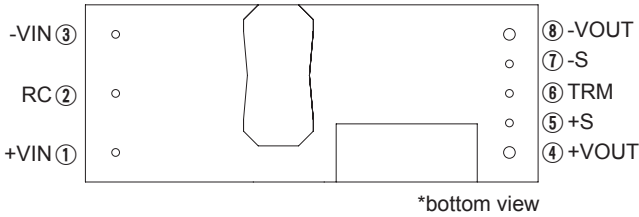

●CHS380

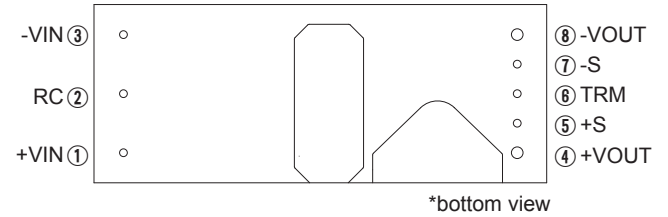

●CHS400/CHS500

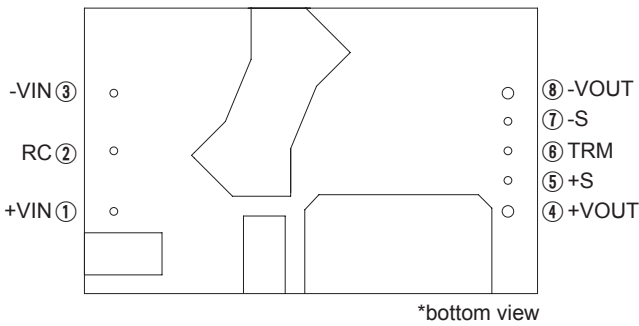

●CHS700

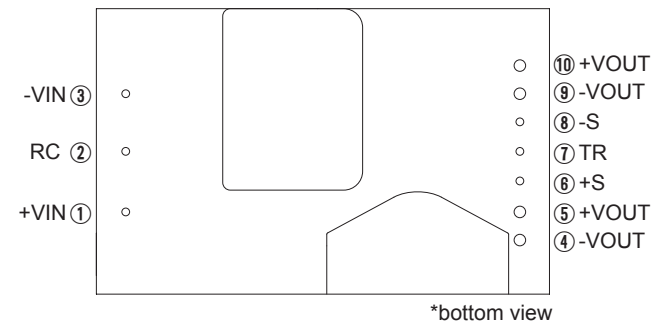

CHS

No.		Pin Connection	Function
CHS60, CHS80, CHS120, CHS200, CHS300, CHS380, CHS400, CHS500	CHS700		
①	①	+VIN	+DC input
②	②	RC	Remote ON/OFF
③	③	-VIN	-DC input
④	⑤,⑩	+VOUT	+DC output
⑤	⑥	+S	+Remote sensing
⑥	⑦	TRM	Adjustment of output voltage
⑦	⑧	-S	-Remote sensing
⑧	④,⑨	-VOUT	-DC output

Implementation · Mounting Method

Mounting method

- The unit can be mounted in any direction. When two or more power supplies are used side by side, position them with proper intervals to allow enough air ventilation. The temperature around each power supply should not exceed the temperature range shown in Instruction Manual 8.
- Avoid placing the DC input line pattern layout underneath the unit. It will increase the line conducted noise. Make sure to leave an ample distance between the line pattern layout and the unit. Also avoid placing the DC output line pattern underneath the unit because it may increase the output noise. Lay out the pattern away from the unit.
- Avoid placing the signal line pattern layout underneath the unit because the power supply might become unstable. Lay out the pattern away from the unit.
- Avoid placing pattern layout in hatched area shown in below to insulate between pattern and power supply.

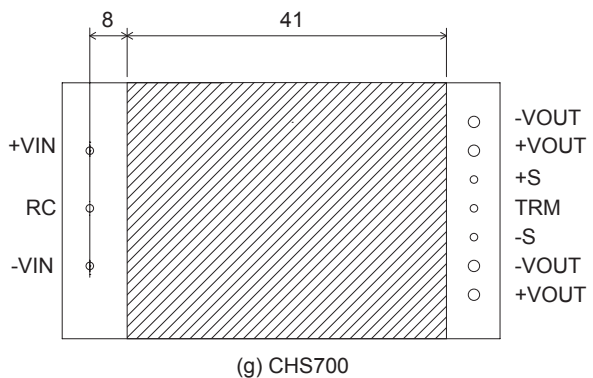
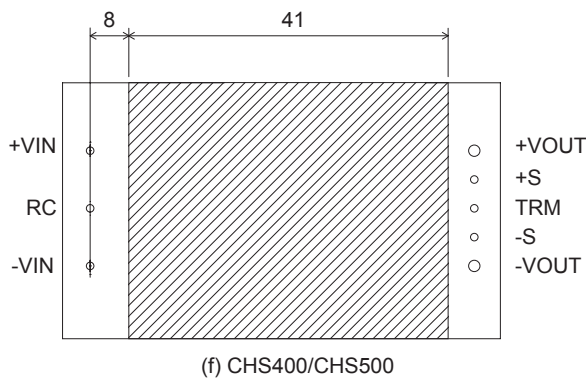
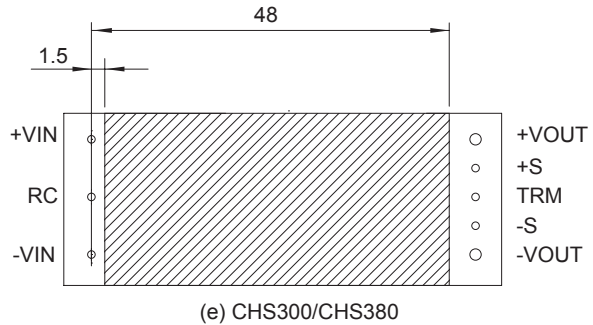
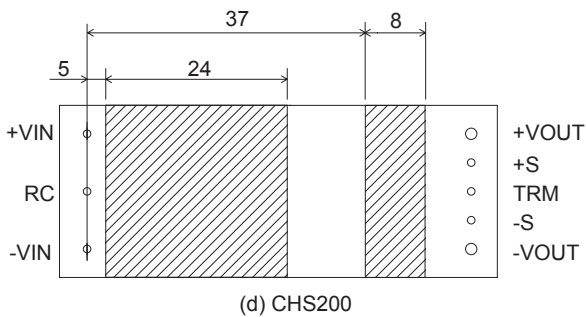
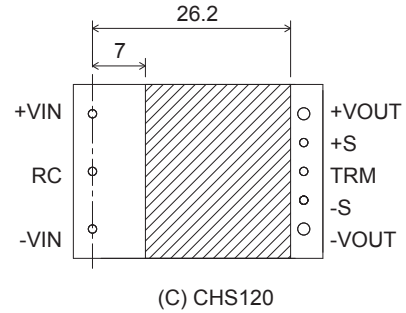
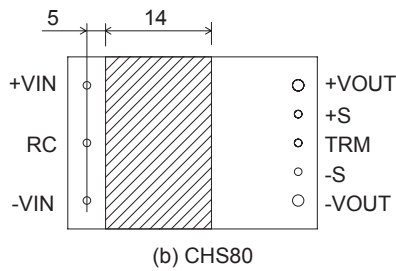
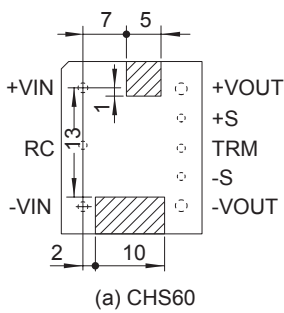

Dimensions in mm

Automatic Mounting (CHS series:option S)

- To mount CHS series automatically, use the inductor area near the output pin as an adsorption point. Please see the External View for details of the adsorption point. If the bottom dead point of a suction nozzle is too low when mounting excessive force is applied to the inductor, it could cause damage. Please mount carefully.

Implementation · Mounting Method

Soldering

- (1)Flow Soldering : 260°C 15 seconds or less
- (2)Soldering Iron : maximum 450°C 5 seconds or less
- (3)Reflow Soldering (option “-S”)

■Right figure shows conditions for the reflow soldering for option “-S” of CHS series. Please make sure that the temperatures of pin terminals +VIN and -VOUT shown in right figure do not exceed the temperatures shown in below.

■If time or temperature of the reflow soldering goes beyond the conditions, reliability of internal components may be compromised.

Please use the unit under the recommended reflow conditions.

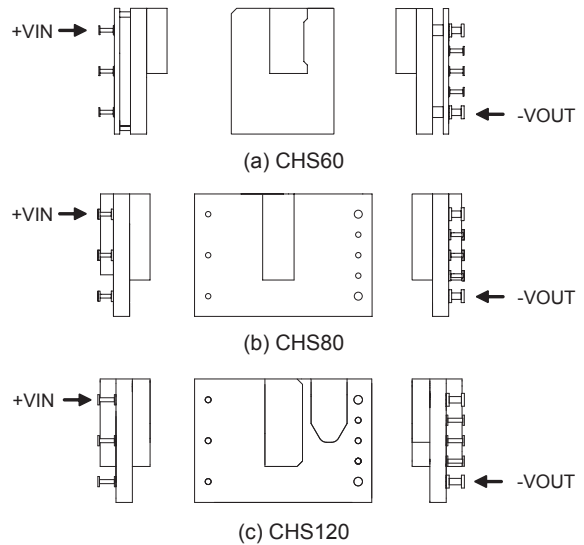
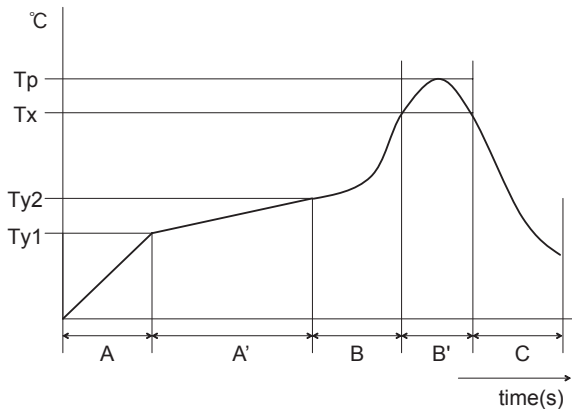

A	1.0 - 5.0°C/s
A'	Ty1:160±10°C Ty2:180±10°C Ty1 - Ty2:120s max
B	1.0 - 5.0°C/s
B'	Tp:Max245°C 10s max Tx:220°C or more:70s max
C	1.0 - 5.0°C/s

Notes to use option “-S”

- Solder iron or other similar methods are not recommended soldering method for option “-S”because it may not be able to retain connection reliability between the PCB and the Pins. Solder reflow is the acceptable mounting system for the option.
- Option “-S”is not reusable product after soldered on any application PCB.

Stress to the pins

■When too much stress is applied to the pins of the power supply, the internal connection may be weakened.

As shown in right figure, avoid applying stress of more than 19.6N (2kgf) to the pins horizontally and more than 39.2N (4kgf) vertically.

- The pins are soldered on PWB internally. Therefore, do not pull bend them with strong force.
- Fix the unit on PCB (using silicone rubber or fixing fittings) to reduce the stress to the pins.
- The base plate at Option“B”and “BC”is attached by glue.

When fixed to cabinet with screw, fix the power module before soldering the input and output pins to prevent the power module being damaged.

When fixed to cabinet with screw, fix the power module before soldering the input and output pins to prevent the power module being damaged.

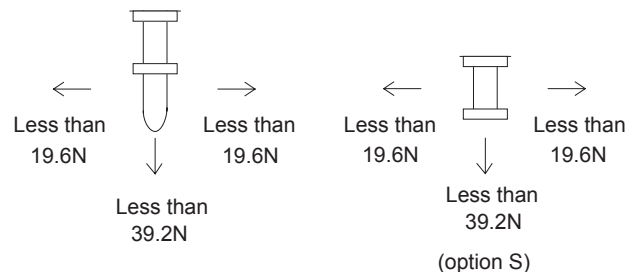

Stress to the product

■CHS series transformer core and choke coil core are attached by glue.

There is a possibility that the core will be removed and power supply will be damaged when they receive stress by the fall or somekind of stress.

■The base plate at Option“B”and “BC”is attached by glue. There is a possibility that the base plate will be removed and power supply will be damaged when they receive stress by the fall or some kind of stress.

Derating

Input Derating

●CHS120 Input Derating

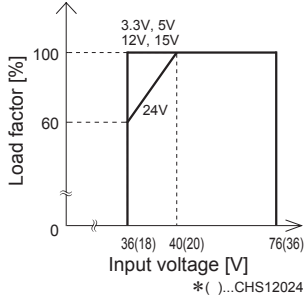

Ambient temperature derating

■Shown the thermal curve with measuring as shown in Instruction Manual 8 Measuring method. Verify final design by actual temperature measurement. Make sure the temperatures at temperature measurement locations shown from Instruction Manual 8. It should not exceed the derating curve in Instruction Manual 8.

●CHS60483R3 Ambient temperature derating (Vin=48V Reference value)

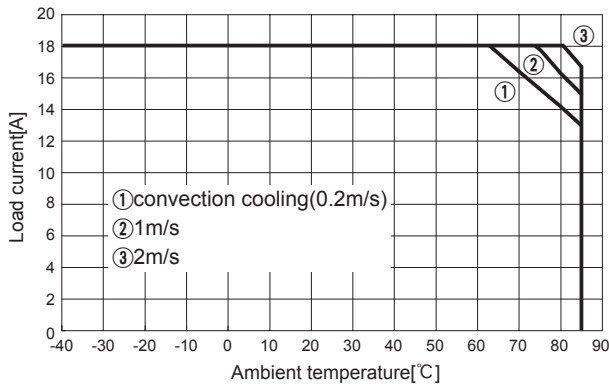

●CHS604805 Ambient temperature derating (Vin=48V Reference value)

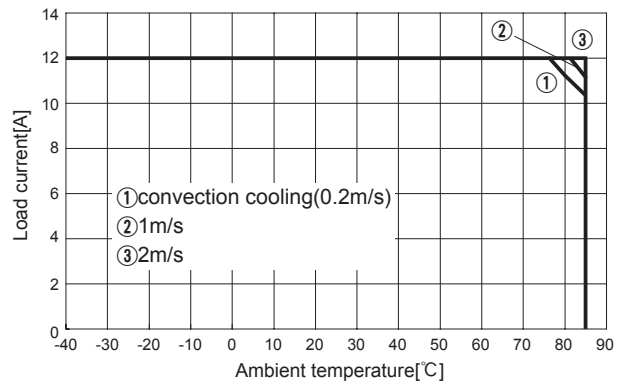

●CHS604812 Ambient temperature derating (Vin=48V Reference value)

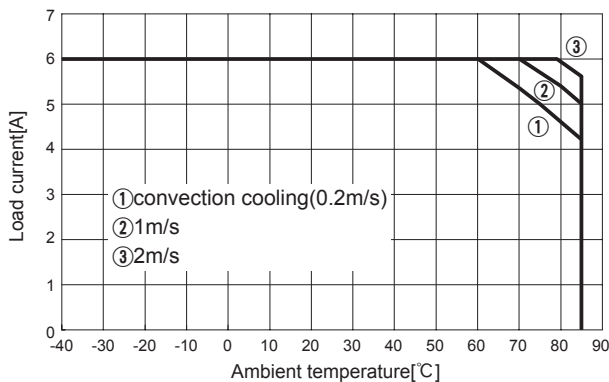

●CHS80483R3 Ambient temperature derating (Vin=48V Reference value)

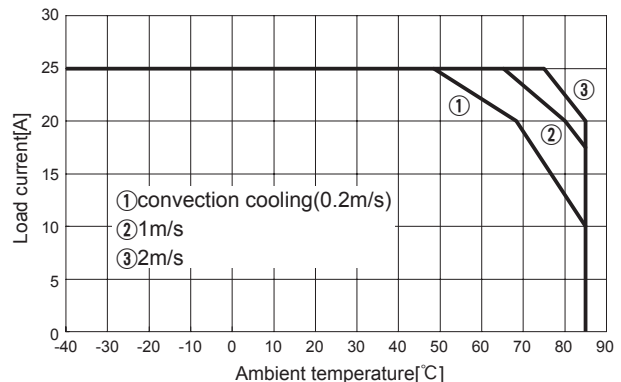

CHS

Derating

●CHS804805 Ambient temperature derating (Vin=48V Reference value)

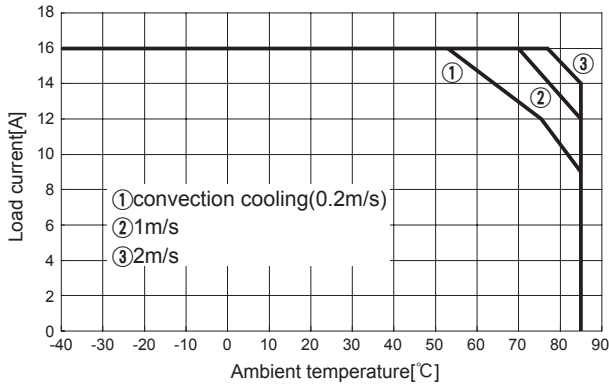

●CHS804812 Ambient temperature derating (Vin=48V Reference value)

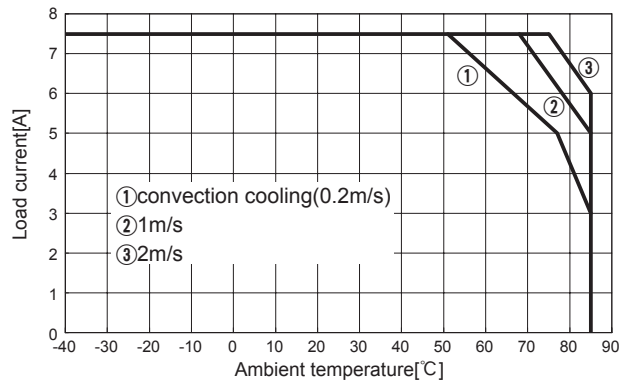

●CHS1202405 Ambient temperature derating (Vin=24V Reference value)

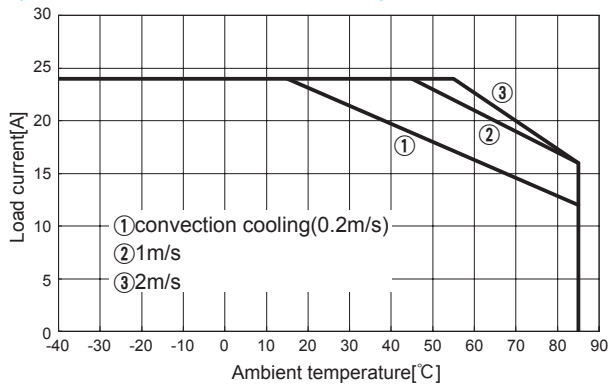

●CHS1202412 Ambient temperature derating (Vin=24V Reference value)

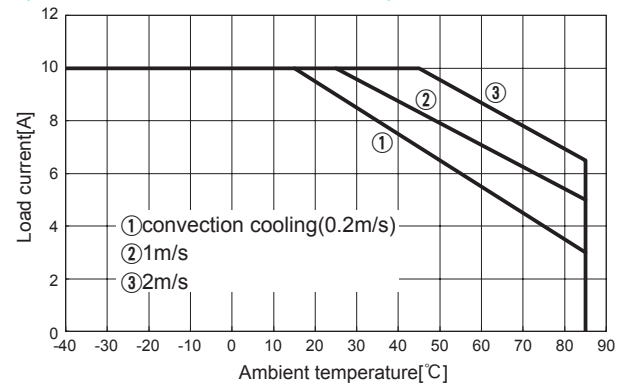

●CHS1202415 Ambient temperature derating (Vin=24V Reference value)

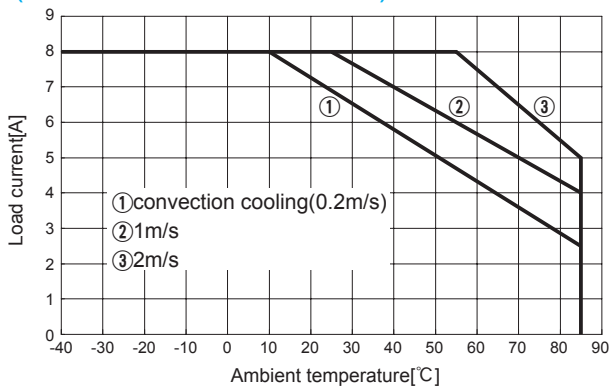

●CHS1202424 Ambient temperature derating (Vin=24V Reference value)

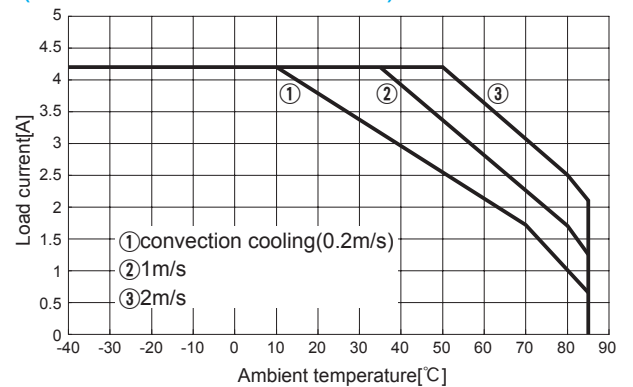

●CHS120483R3 Ambient temperature derating (Vin=48V Reference value)

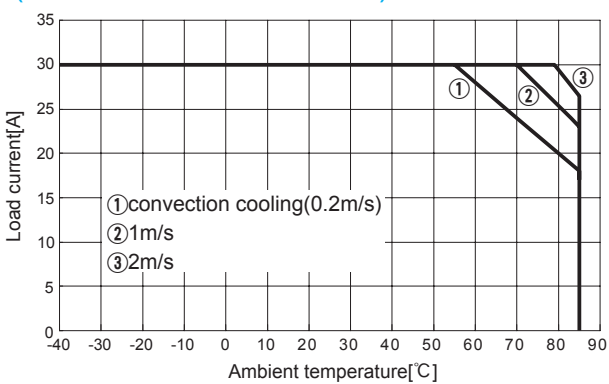

●CHS1204805 Ambient temperature derating (Vin=48V Reference value)

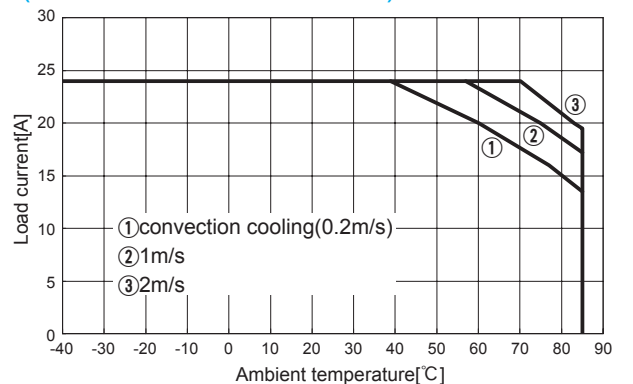

Derating

● **CHS1204812 Ambient temperature derating (Vin=48V Reference value)**

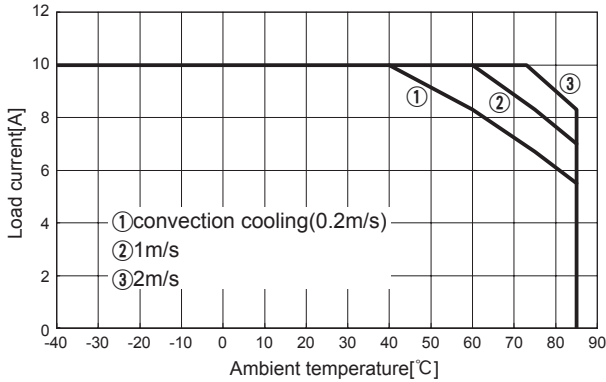

● **CHS1204815 Ambient temperature derating (Vin=48V Reference value)**

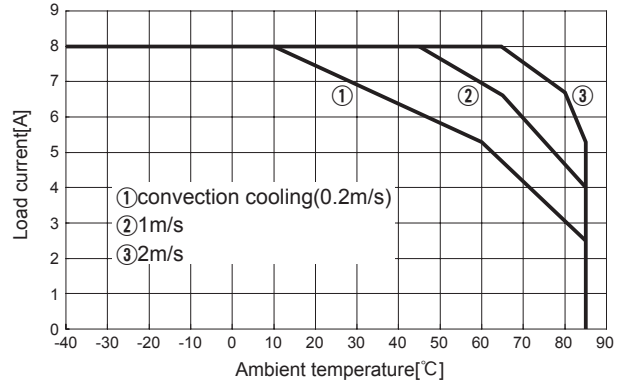

● **CHS1204824 Ambient temperature derating (Vin=48V Reference value)**

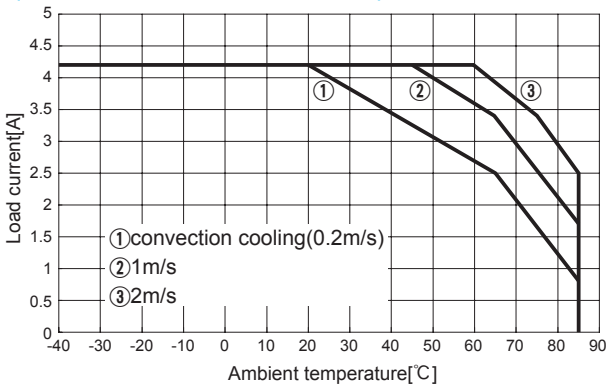

● **CHS200483R3 Ambient temperature derating (Vin=48V Reference value)**

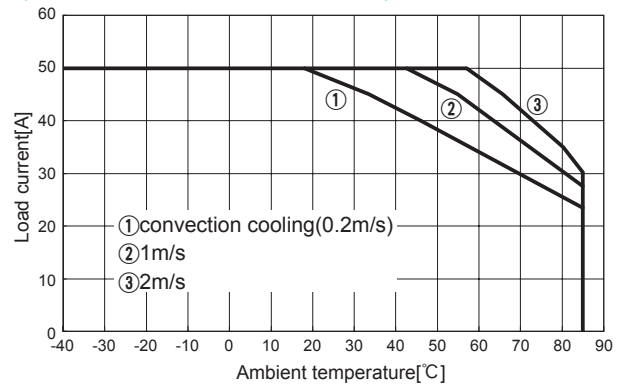

CHS

● **CHS2004805 Ambient temperature derating (Vin=48V Reference value)**

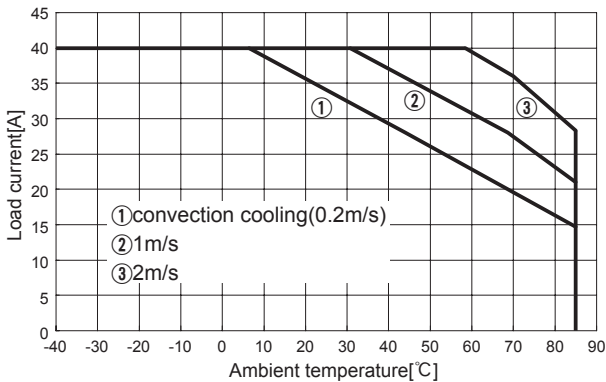

● **CHS2004812 Ambient temperature derating (Vin=48V Reference value)**

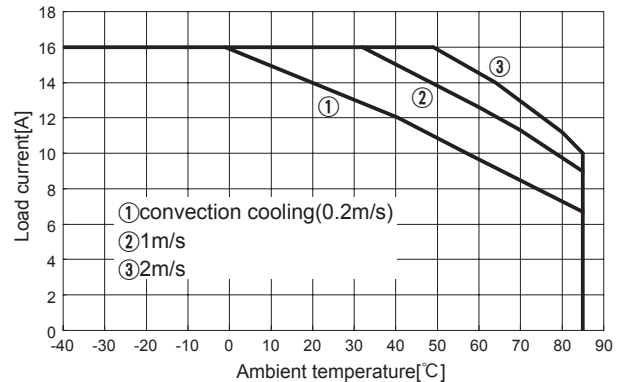

● **CHS3002405 Ambient temperature derating (Vin=24V Reference value)**

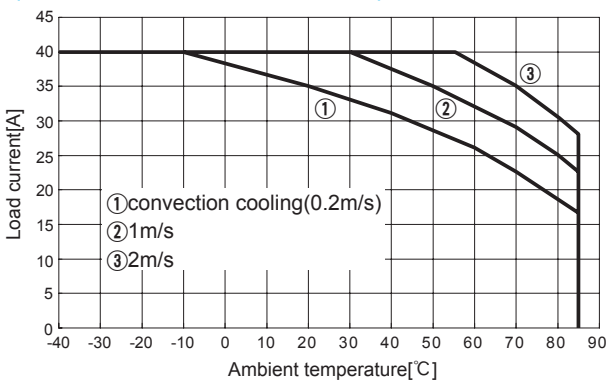

● **CHS3002412 Ambient temperature derating (Vin=24V Reference value)**

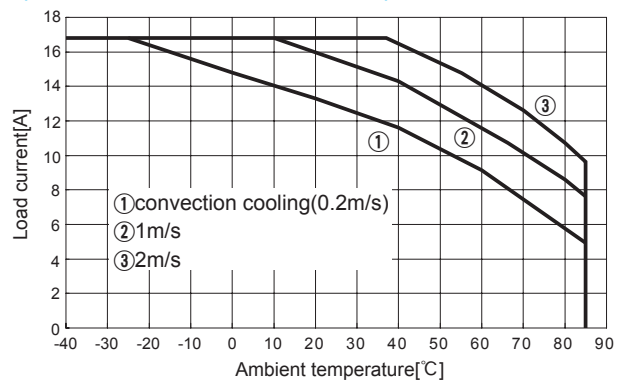

Derating

● CHS3002415 Ambient temperature derating (Vin=24V Reference value)

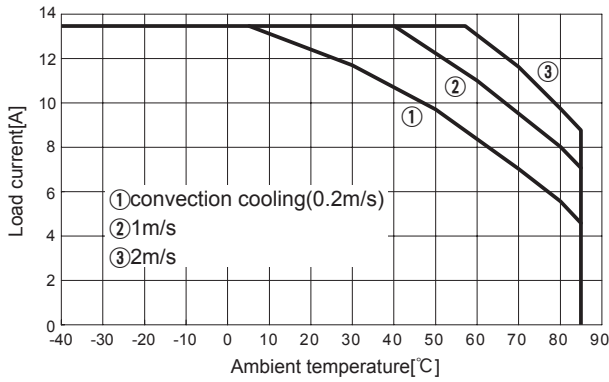

● CHS3002424 Ambient temperature derating (Vin=24V Reference value)

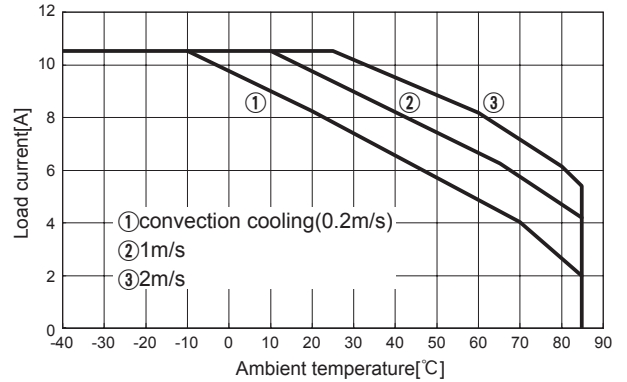

● CHS3002428 Ambient temperature derating (Vin=24V Reference value)

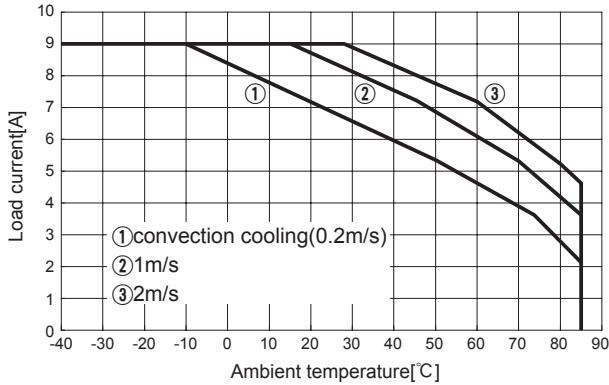

● CHS3002432 Ambient temperature derating (Vin=24V Reference value)

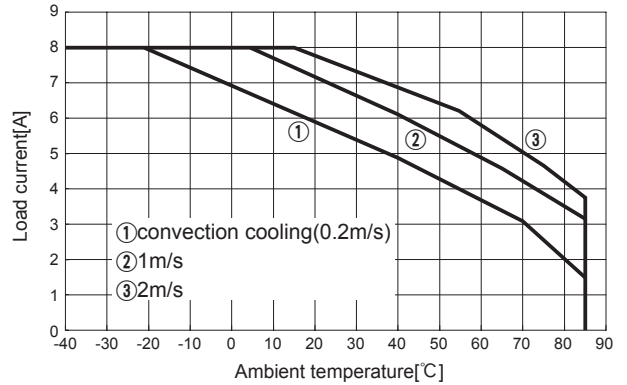

● CHS3002448 Ambient temperature derating (Vin=24V Reference value)

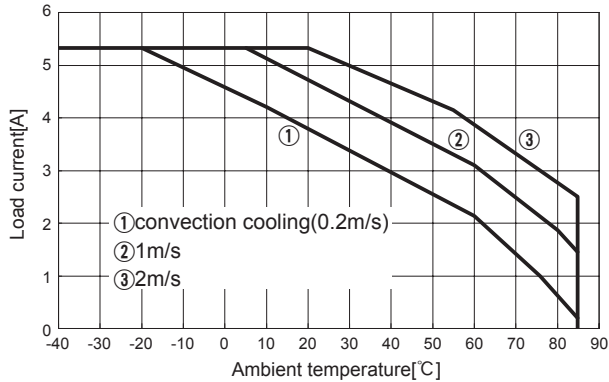

● CHS3004810 Ambient temperature derating (Vin=48V Reference value)

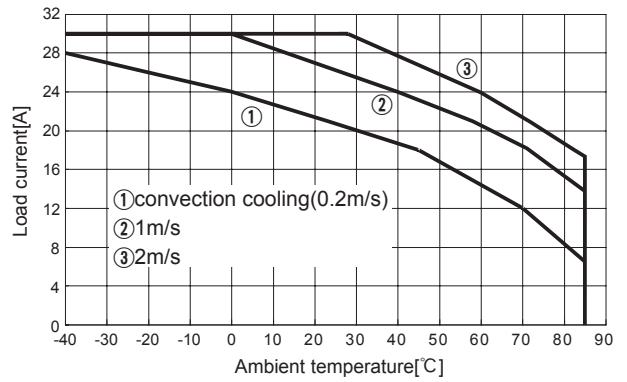

● CHS3004812 Ambient temperature derating (Vin=48V Reference value)

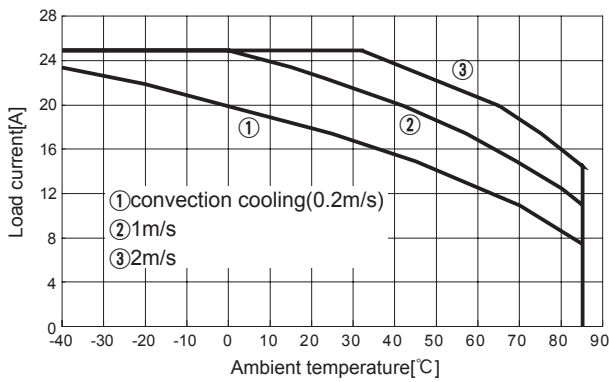

● CHS3004812H Ambient temperature derating (Vin=48V Reference value)

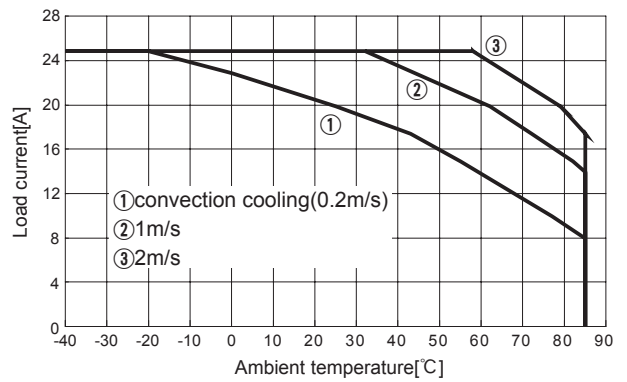

CHS

Derating

●CHS3004815 Ambient temperature derating (Vin=48V Reference value)

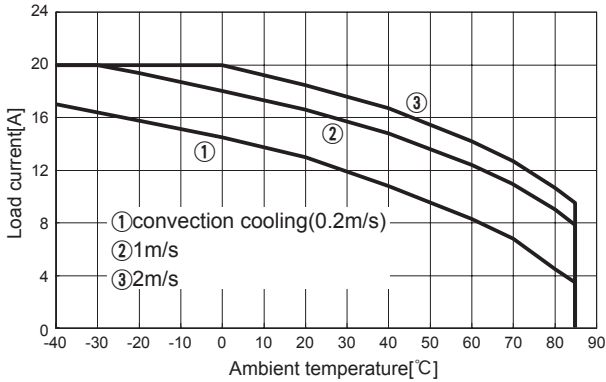

●CHS3004824 Ambient temperature derating (Vin=48V Reference value)

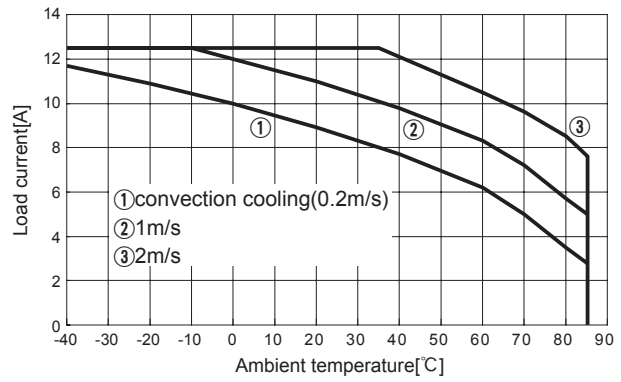

●CHS3004828 Ambient temperature derating (Vin=48V Reference value)

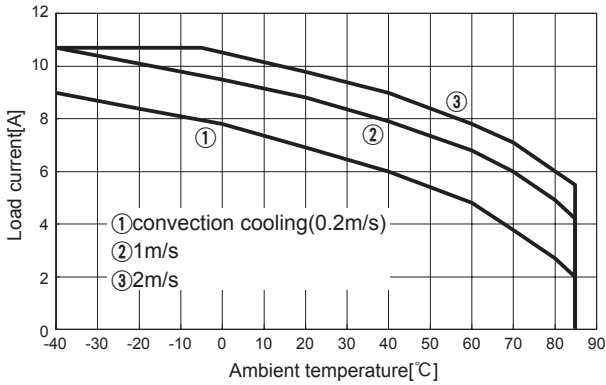

●CHS3004832 Ambient temperature derating (Vin=48V Reference value)

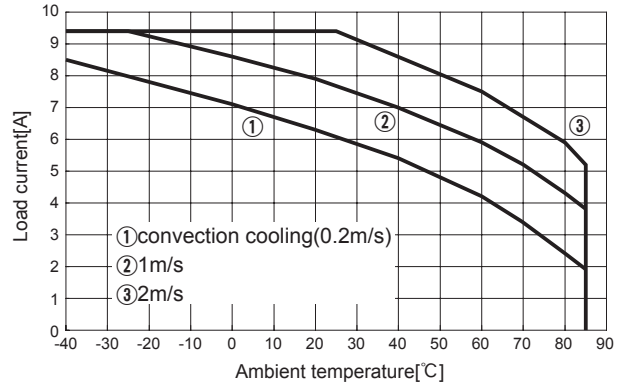

CHS

●CHS3004848 Ambient temperature derating (Vin=48V Reference value)

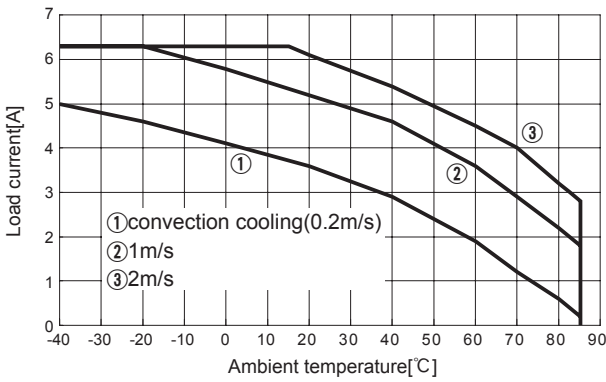

●CHS3804810 Ambient temperature derating (Vin=48V Reference value)

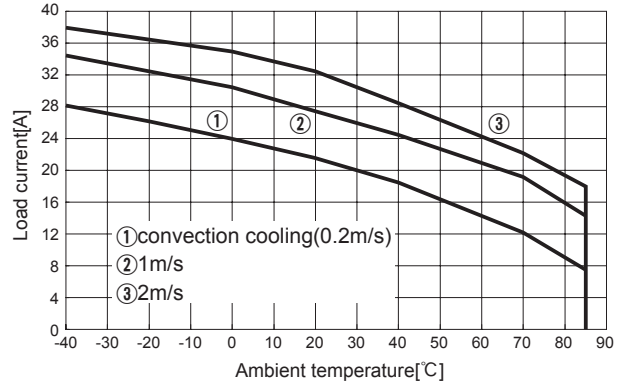

●CHS3804812 Ambient temperature derating (Vin=48V Reference value)

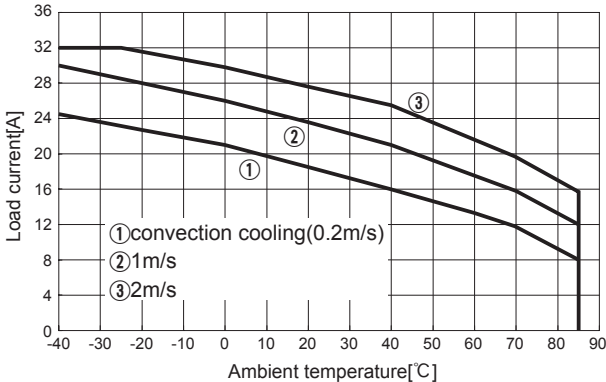

●CHS3804812H Ambient temperature derating (Vin=48V Reference value)

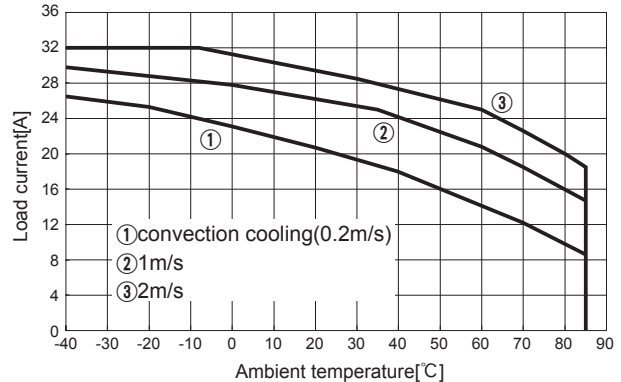

Derating

● CHS4002412 Ambient temperature derating (Vin=24V Reference value)

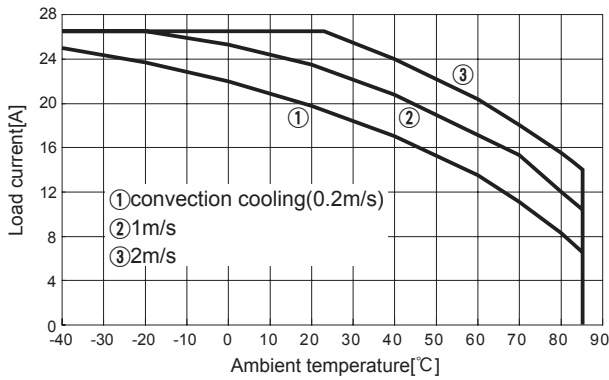

● CHS4002415 Ambient temperature derating (Vin=24V Reference value)

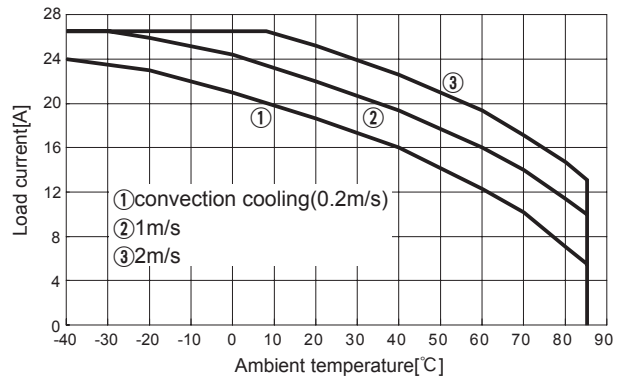

● CHS4002424 Ambient temperature derating (Vin=24V Reference value)

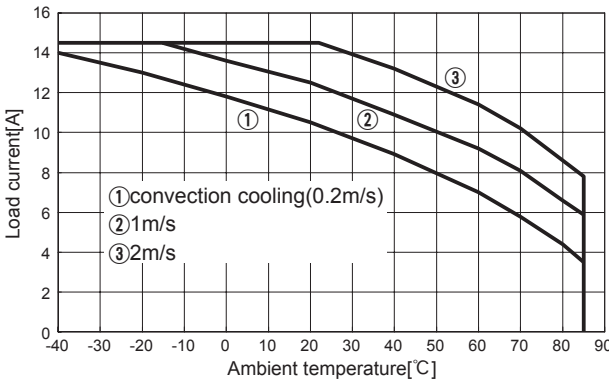

● CHS4002428 Ambient temperature derating (Vin=24V Reference value)

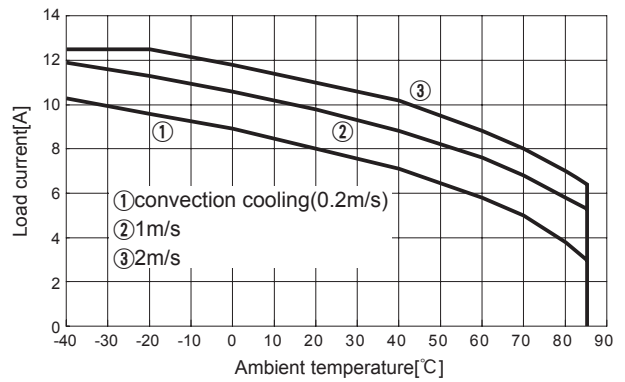

● CHS4002432 Ambient temperature derating (Vin=24V Reference value)

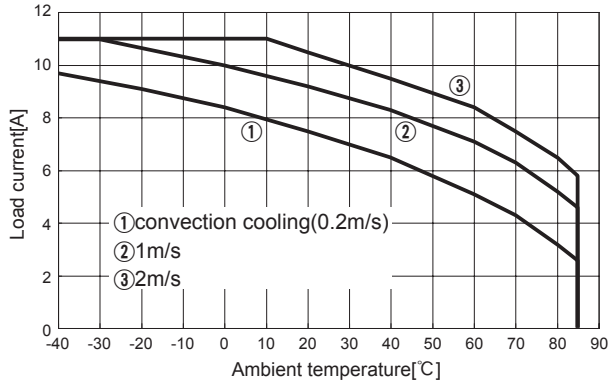

● CHS4002448 Ambient temperature derating (Vin=24V Reference value)

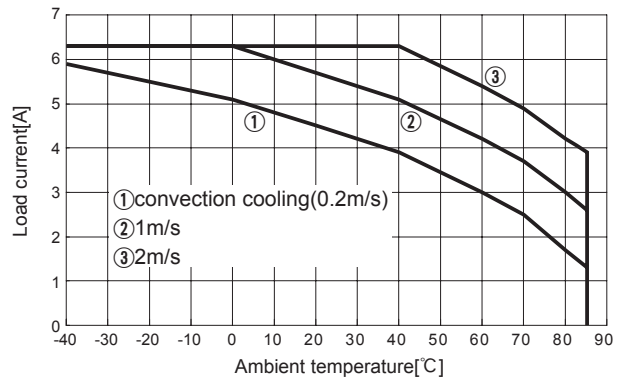

● CHS4004810 Ambient temperature derating (Vin=48V Reference value)

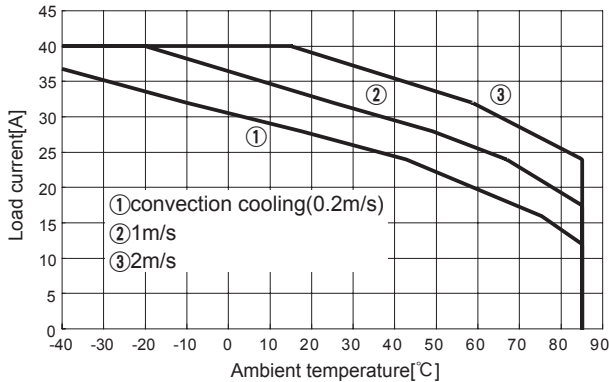

● CHS4004812 Ambient temperature derating (Vin=48V Reference value)

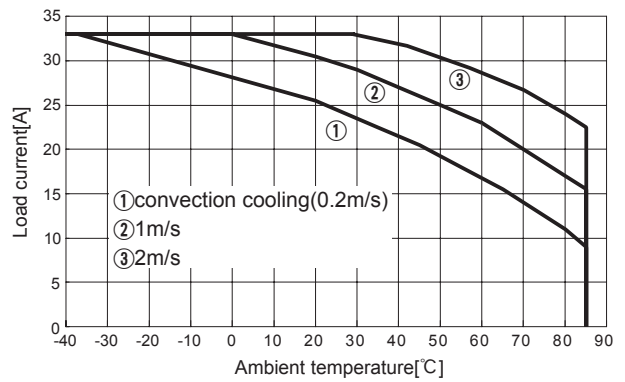

Derating

● **CHS4004812H Ambient temperature derating (Vin=48V Reference value)**

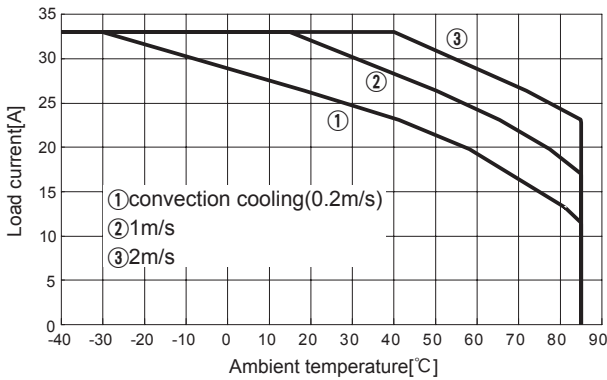

● **CHS4004815 Ambient temperature derating (Vin=48V Reference value)**

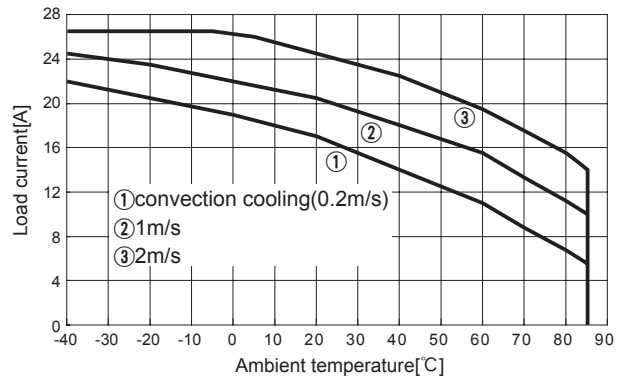

● **CHS4004824 Ambient temperature derating (Vin=48V Reference value)**

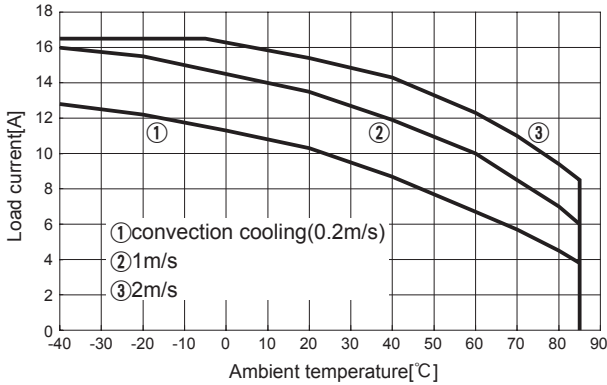

● **CHS4004828 Ambient temperature derating (Vin=48V Reference value)**

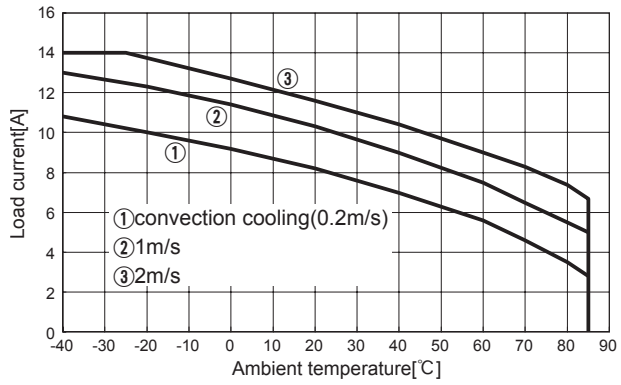

CHS

● **CHS4004832 Ambient temperature derating (Vin=48V Reference value)**

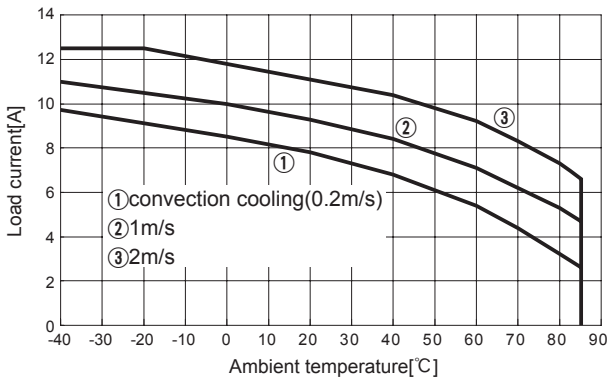

● **CHS4004848 Ambient temperature derating (Vin=48V Reference value)**

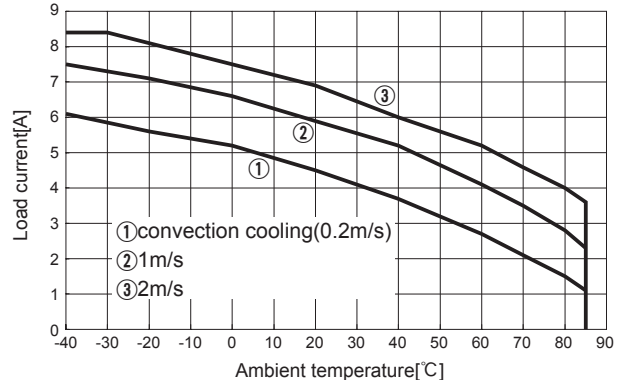

● **CHS5004812 Ambient temperature derating (Vin=48V Reference value)**

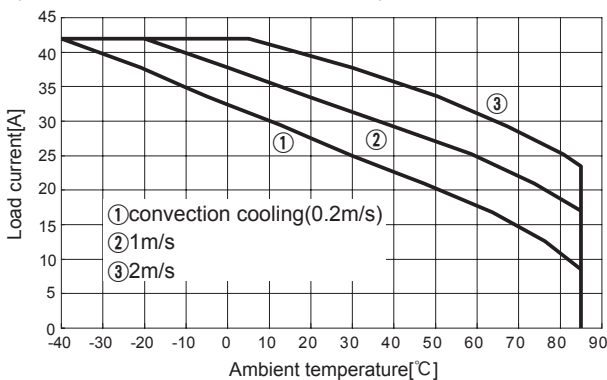

● **CHS7004812H Ambient temperature derating (Vin=48V Reference value)**

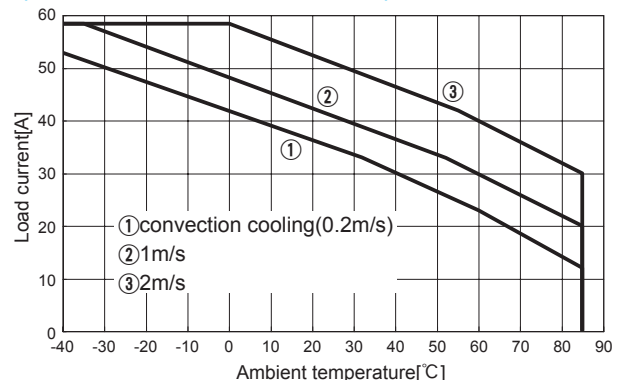

Instruction Manuals

◆ Please see catalog and instruction manual before you use.

Instruction Manuals <https://www.cosel.co.jp/redirect/catalog/en/CHS/>
 Before using our product <https://en.cosel.co.jp/technical/caution/index.html>

CHS



NOTICE



Basic Characteristics Data

Model	Circuit method	Switching frequency [kHz]	Input current	Rated input fuse	Inrush current protection	PCB/Pattern			Series/Redundancy operation availability	
						Material	Single sided	Double sided	Series operation	Redundancy operation
CHS60	Foward converter	440	*1	-	-	glass fabric base, epoxy resin		Multilayer	Yes	*2
CHS80	Half-bridge converter	250	*1	-	-	glass fabric base, epoxy resin		Multilayer	Yes	*2
CHS12024	Half-bridge converter	180	*1	-	-	glass fabric base, epoxy resin		Multilayer	Yes	*2
CHS12048	Half-bridge converter	200	*1	-	-	glass fabric base, epoxy resin		Multilayer	Yes	*2
CHS200	Full-bridge converter	150	*1	-	-	glass fabric base, epoxy resin		Multilayer	Yes	*2
CHS30024 (05,12,15)	Full-bridge converter	170	*1	-	-	glass fabric base, epoxy resin		Multilayer	Yes	*2
CHS30024 (24,28,32,48)	Full-bridge converter	170	*1	-	-	glass fabric base, epoxy resin		Multilayer	Yes	*2
CHS30048 (10,12,12H)	Full-bridge converter	170	*1	-	-	glass fabric base, epoxy resin		Multilayer	Yes	*2
CHS30048 (15,24,28,32,48)	Full-bridge converter	170	*1	-	-	glass fabric base, epoxy resin		Multilayer	Yes	*2
CHS380 (4810,4812)	Full-bridge converter	200	*1	-	-	glass fabric base, epoxy resin		Multilayer	Yes	*2
CHS380 (4812H)	Full-bridge converter	180	*1	-	-	glass fabric base, epoxy resin		Multilayer	Yes	*2
CHS40024	Full-bridge converter	150	*1	-	-	glass fabric base, epoxy resin		Multilayer	Yes	*2
CHS40048 (10,12,12H)	Full-bridge converter	150	*1	-	-	glass fabric base, epoxy resin		Multilayer	Yes	*2
CHS40048 (15,24,28,32,48)	Full-bridge converter	150	*1	-	-	glass fabric base, epoxy resin		Multilayer	Yes	*2
CHS500	Full-bridge converter	150	*1	-	-	glass fabric base, epoxy resin		Multilayer	Yes	*2
CHS700	Full-bridge converter	160	*1	-	-	glass fabric base, epoxy resin		Multilayer	Yes	*2

*1 Refer to Specification.

*2 Refer to Instruction Manual.



CQHS-series

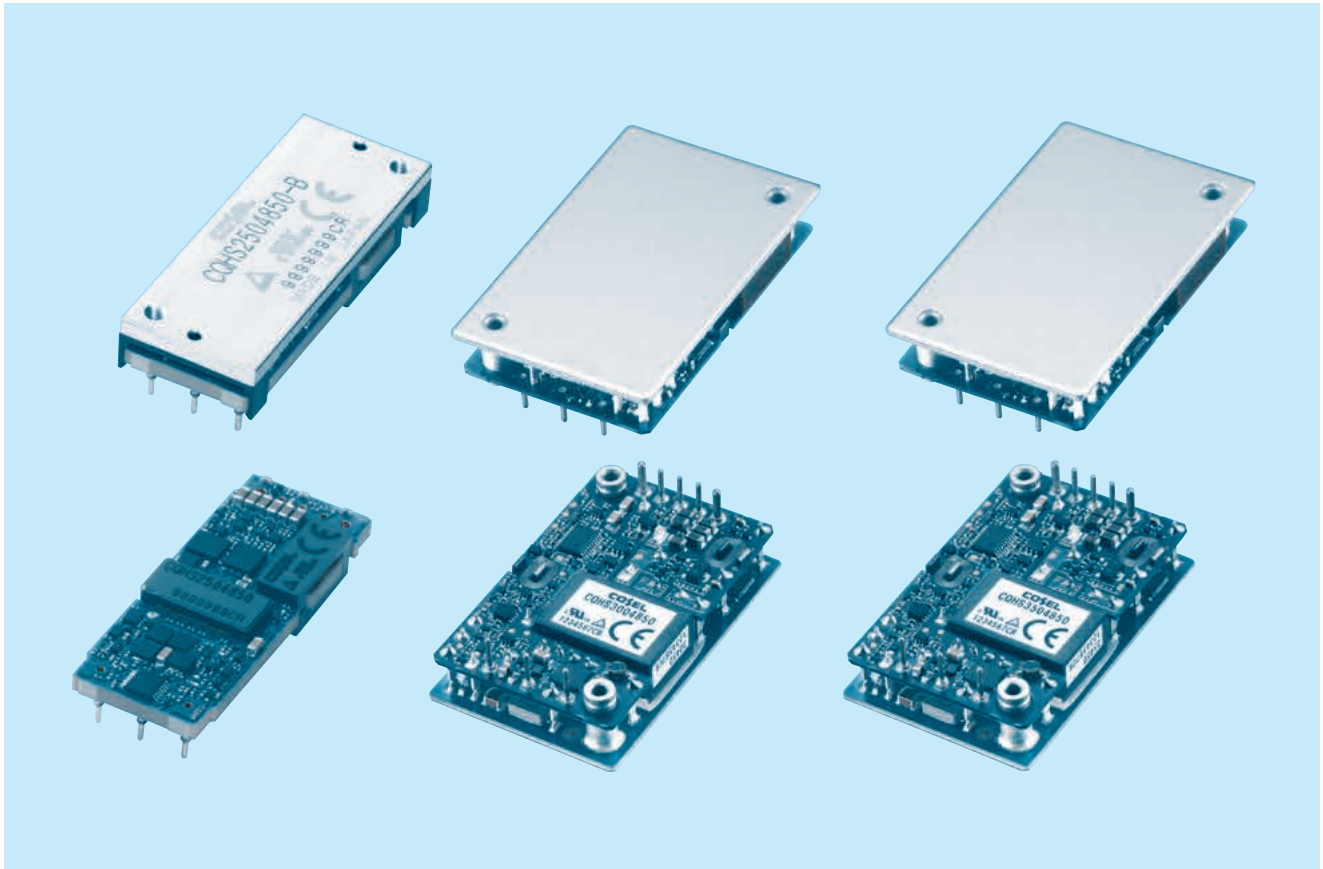

CQHS

■ Feature

Compact DC-DC Converter, " BRICK SIZE" which has been standard size for Telecommunication Market
 High efficiency (synchronous rectifier circuit)
 High density
 High reliability : not built-in aluminum and tantalum electrolytic capacitor
 Built-in overcurrent, overvoltage and thermal protection circuits
 Built-in remote ON/OFF
 Mounting hole (M3 tapped)

■ CE marking

Low Voltage Directive
 RoHS Directive

■ UKCA marking

Electrical Equipment Safety Regulations
 RoHS Regulations

■ Safety agency approvals

UL60950-1, C-UL, EN62368-1

■ 5-year warranty

■ Optional parts

Heat sink (optional parts : CQHS300/CQHS350)

CQHS250

CQH S 250 48 50 -□

① ② ③ ④ ⑤ ⑥

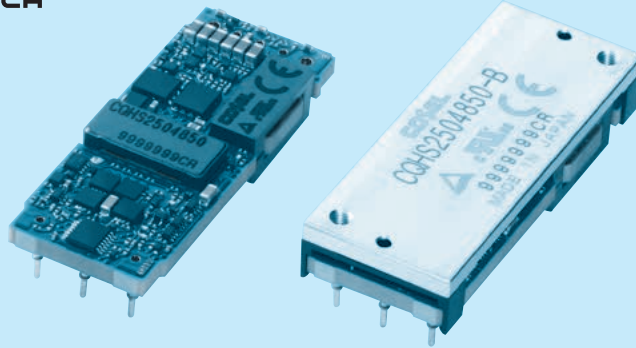
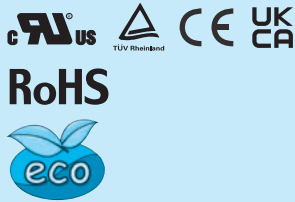

- ① Series name
- ② Single output
- ③ Output wattage
- ④ Input voltage
48:DC36 - 76V
- ⑤ Output voltage
- ⑥ Optional
- R :with Remote ON/OFF
Positive logic control
- N :Auto restart in protection
circuit working
- B :Base plate option with
Mounting hole M3
- L2:Pin length 5.3mm

MODEL	CQHS2504832	CQHS2504850
MAX OUTPUT WATTAGE[W]	252.8	250
DC OUTPUT	32V 7.9A	50V 5.0A

SPECIFICATIONS

	MODEL	CQHS2504832	CQHS2504850	
INPUT	VOLTAGE[V]	DC36 - 76		
	CURRENT[A]	5.60typ	5.54typ	
	EFFICIENCY[%]	94typ	94typ	
	START-UP VOLTAGE[V]	DC32 - 36		
	HYSTERESIS VOLTAGE[V]	DC2 min		
OUTPUT	VOLTAGE[V]	32	50	
	CURRENT[A]	7.9	5.0	
	LINE REGULATION[mV]	64max	100max	
	LOAD REGULATION[mV]	64max	100max	
	RIPPLE[mVp-p]	-20 to +85°C Vin=36-60V *2	255max	400max
		-20 to +85°C Vin=60-76V *2	320max	500max
		-40 to -20°C *2	320max	500max
	RIPPLE NOISE[mVp-p]	-20 to +85°C *2	320max	500max
		-40 to -20°C *2	410max	650max
	TEMPERATURE REGULATION[mV]	-40 to +85°C	640max	1000max
	DRIFT[mV]	*3	120max	185max
START-UP TIME[ms]	200max (DCIN 48V, Io=100%)			
OUTPUT VOLTAGE ADJUSTMENT RANGE[V] *4	Fixed (TRM pin open), adjustable by external resistor			
	26.88 - 35.20	45.0 - 55.0		
OUTPUT VOLTAGE SETTING[V]*1	31.68 - 32.32	49.50 - 50.50		
PROTECTION CIRCUIT AND OTHERS	OVERCURRENT PROTECTION	Works over 105% of rating, low voltage protection (shut down) function is built-in.		
	OVERVOLTAGE PROTECTION[V]	36.80 - 44.80	56.50 - 67.50	
	REMOTE SENSING	Provided		
REMOTE ON/OFF	Provided (Negative Logic L : ON, H :OFF)			
ISOLATION	INPUT-OUTPUT	DC1,500V or AC500V 1minute, Cutoff current = 10mA, DC500V 50MΩ min (20±15°C)		
	INPUT-BASE PLATE	*5 DC1,500V or AC500V 1minute, Cutoff current = 10mA, DC500V 50MΩ min (20±15°C)		
	OUTPUT-BASE PLATE	*5 AC500V 1minute, Cutoff current = 100mA, DC500V 50MΩ min (20±15°C)		
ENVIRONMENT	OPERATING TEMP.,HUMID.AND ALTITUDE	-40 to +85°C, 20 - 95%RH (Non condensing) (Refer to "Derating"), 3,000m (10,000 feet) max		
	STORAGE TEMP.,HUMID.AND ALTITUDE	-40 to +100°C, 20 - 95%RH (Non condensing), 9,000m (30,000 feet) max		
	VIBRATION	10 - 55Hz, 49.0m/s ² (5G), 3minutes period, 60minutes each along X, Y and Z axis		
	IMPACT	196.1m/s ² (20G), 11ms, once each along X, Y and Z axis		
SAFETY	AGENCY APPROVALS	UL60950-1, C-UL (CSA60950-1), EN62368-1		
OTHERS	CASE SIZE/WEIGHT	57.9 × 10.5 × 22.76mm [2.28 × 0.41 × 0.9 inches] (W × H × D) / 30g max		
	COOLING METHOD	58.4 × 12.7 × 23.26mm [2.3 × 0.5 × 0.92 inches] (W × H × D) / 45g max *5		
	CONVECTION METHOD	Convection / Forced air / Conduction		

*1 At rated input(DC48V), rated load. Ta= 25°C, 2m/s.
 *2 Ripple and ripple noise is measured by using measuring board. Refer to the manual.
 *3 Drift is the change in DC output for an eight hour period after a half-hour warm-up at 25°C, with the input voltage held constant at the rated input/output.
 *4 When the input voltage is in the range of DC36-40V, output voltage is limited. Refer to the manual.
 *5 Base Plate Option.

External view

1. DIP

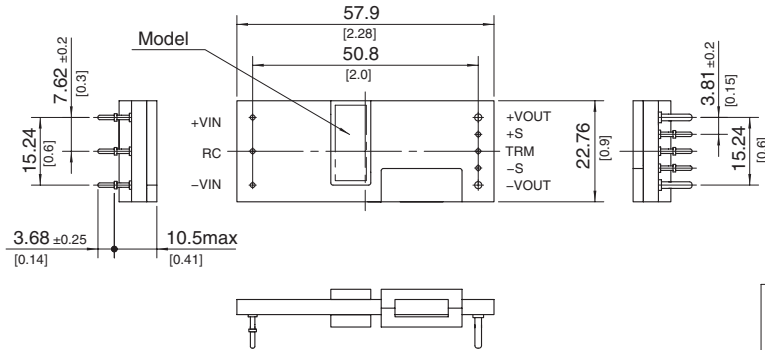

- ※ Tolerance : ±0.5 [±0.02]
- ※ Weight : 30g max(DIP)
45g max(Base Plate)
- ※ Dimensions in mm, []=inches

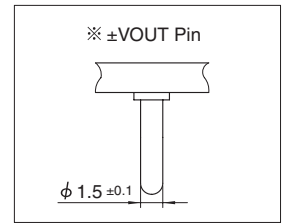
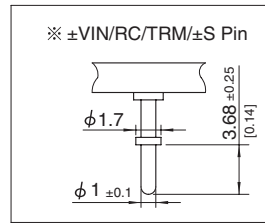

2. Base Plate (option B)

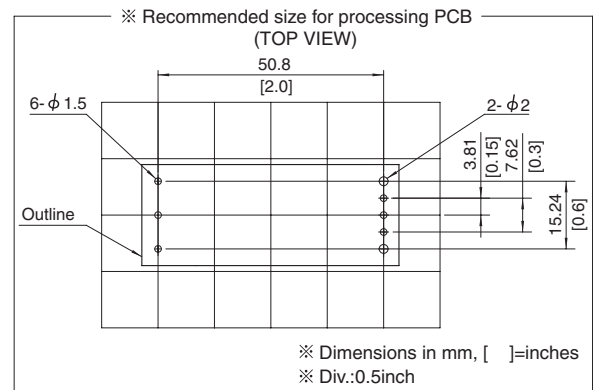
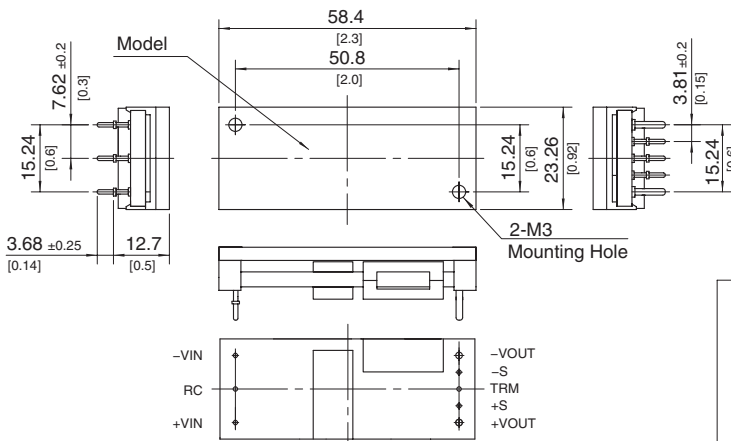

CQHS300

CQH S 300 48 50 -□

① ② ③ ④ ⑤ ⑥

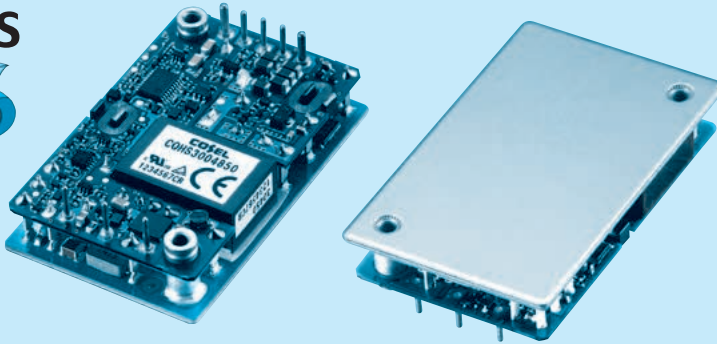
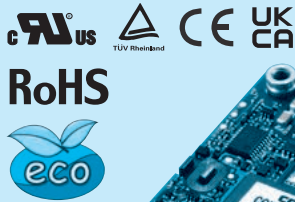

*Providing heat sink as option

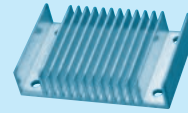

- ① Series name
- ② Single output
- ③ Output wattage
- ④ Input voltage
48:DC36 - 76V
- ⑤ Output voltage
- ⑥ Optional
- R :with Remote ON/OFF
Positive logic control
- T :with Mounting hole
φ 3.4 thru

MODEL	CQHS3004832	CQHS3004850
MAX OUTPUT WATTAGE[W]	300.8	300
DC OUTPUT	32V 9.4A	50V 6A

SPECIFICATIONS

	MODEL	CQHS3004832	CQHS3004850	
INPUT	VOLTAGE[V]	DC36 - 76		
	CURRENT[A]	6.67typ	6.65typ	
	EFFICIENCY[%]	94typ	94typ	
	START-UP VOLTAGE[V]	DC32 - 36		
	HYSTERESIS VOLTAGE[V]	DC2 min		
OUTPUT	VOLTAGE[V]	32	50	
	CURRENT[A]	9.4	6.0	
	LINE REGULATION[mV]	64max	100max	
	LOAD REGULATION[mV]	64max	100max	
	RIPPLE[mVp-p]	-20 to +100°C *2	255max	400max
		-40 to -20°C Vin=36-60V *2	320max	500max
		-40 to -20°C Vin=60-76V *2	400max	500max
	RIPPLE NOISE[mVp-p]	-20 to +100°C *2	320max	500max
		-40 to -20°C *2	410max	650max
	TEMPERATURE REGULATION[mV]	0 to +65°C	320max	500max
		-40 to +100°C	640max	1000max
DRIFT[mV]	*3	120max	185max	
START-UP TIME[ms]		200max (DCIN 48V, Io=100%)		
OUTPUT VOLTAGE ADJUSTMENT RANGE[V] *4		Fixed (TRM pin open), adjustable by external resistor		
		27.2 - 35.2	45.0 - 55.0	
OUTPUT VOLTAGE SETTING[V]*1		31.68 - 32.32	49.50 - 50.50	
PROTECTION CIRCUIT AND OTHERS	OVERCURRENT PROTECTION	Works over 105% of rating, low voltage protection (shut down) function is built-in.		
	OVERVOLTAGE PROTECTION[V]	36.80 - 44.80	56.50 - 67.50	
	REMOTE SENSING	Provided		
REMOTE ON/OFF	Provided (Negative Logic L : ON, H :OFF)			
ISOLATION	INPUT-OUTPUT	DC1,500V or AC500V 1minute, Cutoff current = 10mA, DC500V 50MΩ min (20±15°C)		
	INPUT-BASE PLATE	DC1,500V or AC500V 1minute, Cutoff current = 10mA, DC500V 50MΩ min (20±15°C)		
	OUTPUT-BASE PLATE	AC500V 1minute, Cutoff current = 100mA, DC500V 50MΩ min (20±15°C)		
ENVIRONMENT	OPERATING TEMP., HUMID. AND ALTITUDE	-40 to +100°C (On aluminum base plate), 20 - 95%RH (Non condensing) (Refer to "Derating"), 3,000m (10,000 feet) max		
	STORAGE TEMP., HUMID. AND ALTITUDE	-40 to +100°C, 20 - 95%RH (Non condensing), 9,000m (30,000 feet) max		
	VIBRATION	10 - 55Hz, 49.0m/s ² (5G), 3minutes period, 60minutes each along X, Y and Z axis		
	IMPACT	196.1m/s ² (20G), 11ms, once each along X, Y and Z axis		
SAFETY	AGENCY APPROVALS	UL60950-1, C-UL (CSA60950-1), EN62368-1		
OTHERS	CASE SIZE/WEIGHT	57.9×12.7×36.8mm [2.28×0.5×1.45 inches] (W×H×D) / 75g max		
	COOLING METHOD	Conduction cooling (e.g. heat radiation from the aluminum base plate to the attached heat sink)		

*1 At rated input(DC48V), rated load, and aluminum base plate temperature 25°C.
 *2 Ripple and ripple noise is measured by using measuring board with recommended capacitor Co & the film capacitor 0.1 μF.
 *3 Drift is the change in DC output for an eight hour period after a half-hour warm-up at 25°C, with the input voltage held constant at the rated input/output.
 *4 When the input voltage is in the range of DC36-40V, output voltage is limited. Refer to the manual.

External view

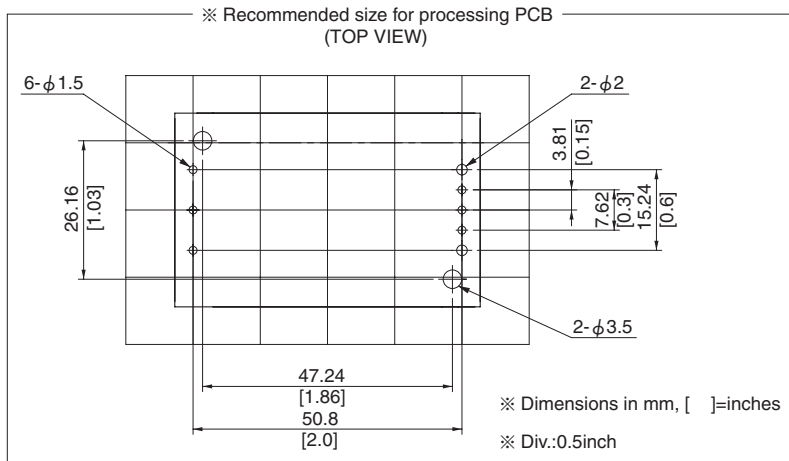
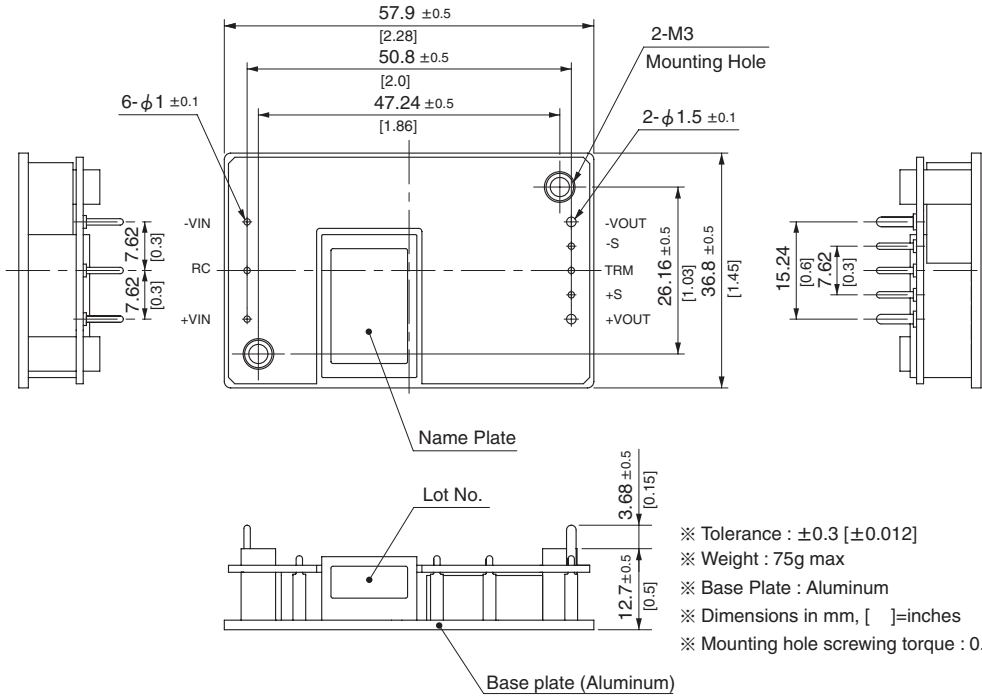

CQHS350

CQH S 350 48 50 -□

① ② ③ ④ ⑤ ⑥

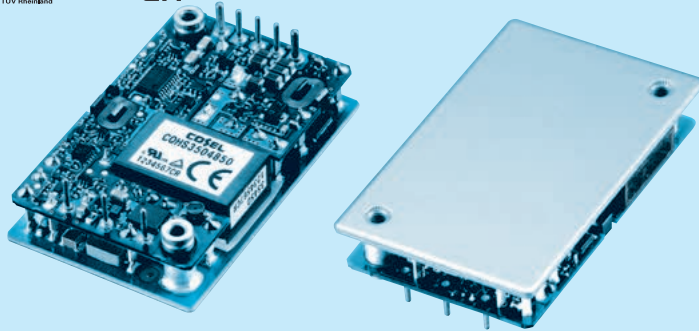
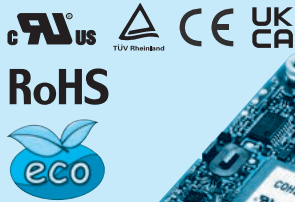

*Providing heat sink as option

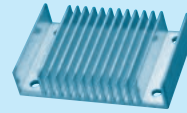

- ① Series name
- ② Single output
- ③ Output wattage
- ④ Input voltage
48:DC36 - 65V
- ⑤ Output voltage
- ⑥ Optional
- R :with Remote ON/OFF
Positive logic control
- T :with Mounting hole
φ 3.4 thru

MODEL	CQHS3504832	CQHS3504850
MAX OUTPUT WATTAGE[W]	352	350
DC OUTPUT	32V 11A	50V 7A

SPECIFICATIONS

	MODEL	CQHS3504832	CQHS3504850	
INPUT	VOLTAGE[V]	DC36 - 65		
	CURRENT[A]	7.8typ	7.76typ	
	EFFICIENCY[%]	94typ	94typ	
	START-UP VOLTAGE[V]	DC32 - 36		
	HYSTERESIS VOLTAGE[V]	DC2 min		
OUTPUT	VOLTAGE[V]	32	50	
	CURRENT[A]	11.0 *5	7.0	
	LINE REGULATION[mV]	64max	100max	
	LOAD REGULATION[mV]	64max	100max	
	RIPPLE[mVp-p]	-20 to +100°C *2	255max	400max
		-40 to -20°C Vin=36-60V *2	320max	500max
		-40 to -20°C Vin=60-65V *2	400max	500max
	RIPPLE NOISE[mVp-p]	-20 to +100°C *2	320max	500max
		-40 to -20°C *2	410max	650max
	TEMPERATURE REGULATION[mV]	0 to +65°C	320max	500max
		-40 to +100°C	640max	1000max
	DRIFT[mV]	*3	120max	185max
START-UP TIME[ms]	200max (DCIN 48V, Io=100%)			
OUTPUT VOLTAGE ADJUSTMENT RANGE[V] *4	Fixed (TRM pin open), adjustable by external resistor			
	26.88 - 35.20			
	45.0 - 55.0			
OUTPUT VOLTAGE SETTING[V]*1	31.68 - 32.32	49.50 - 50.50		
PROTECTION CIRCUIT AND OTHERS	OVERCURRENT PROTECTION	Works over 105% of rating, low voltage protection (shut down) function is built-in.		
	OVERVOLTAGE PROTECTION[V]	36.80 - 44.80	56.50 - 67.50	
	REMOTE SENSING	Provided		
	REMOTE ON/OFF	Provided (Negative Logic L : ON, H :OFF)		
ISOLATION	INPUT-OUTPUT	DC1,500V or AC500V 1minute, Cutoff current = 10mA, DC500V 50MΩ min (20±15°C)		
	INPUT-BASE PLATE	DC1,500V or AC500V 1minute, Cutoff current = 10mA, DC500V 50MΩ min (20±15°C)		
	OUTPUT-BASE PLATE	AC500V 1minute, Cutoff current = 100mA, DC500V 50MΩ min (20±15°C)		
ENVIRONMENT	OPERATING TEMP.,HUMID.AND ALTITUDE	-40 to +100°C (On aluminum base plate), 20 - 95%RH (Non condensing) (Refer to "Derating"), 3,000m (10,000 feet) max		
	STORAGE TEMP.,HUMID.AND ALTITUDE	-40 to +100°C, 20 - 95%RH (Non condensing), 9,000m (30,000 feet) max		
	VIBRATION	10 - 55Hz, 49.0m/s ² (5G), 3minutes period, 60minutes each along X, Y and Z axis		
	IMPACT	196.1m/s ² (20G), 11ms, once each along X, Y and Z axis		
SAFETY	AGENCY APPROVALS	UL60950-1, C-UL (CSA60950-1), EN62368-1		
OTHERS	CASE SIZE/WEIGHT	57.9×12.7×36.8mm [2.28×0.5×1.45 inches] (W×H×D) / 75g max		
	COOLING METHOD	Conduction cooling (e.g. heat radiation from the aluminum base plate to the attached heat sink)		

*1 At rated input(DC48V), rated load, and aluminum base plate temperature 25°C.
 *2 Ripple and ripple noise is measured by using measuring board with recommended capacitor Co & the film capacitor 0.1 μF.
 *3 Drift is the change in DC output for an eight hour period after a half-hour warm-up at 25°C, with the input voltage held constant at the rated input/output.
 *4 When the input voltage is in the range of DC36-40V, output voltage is limited. Refer to the manual.
 *5 Rated current is increased adjusting output voltage to lower than rated output voltage. Refer to the manual.

External view

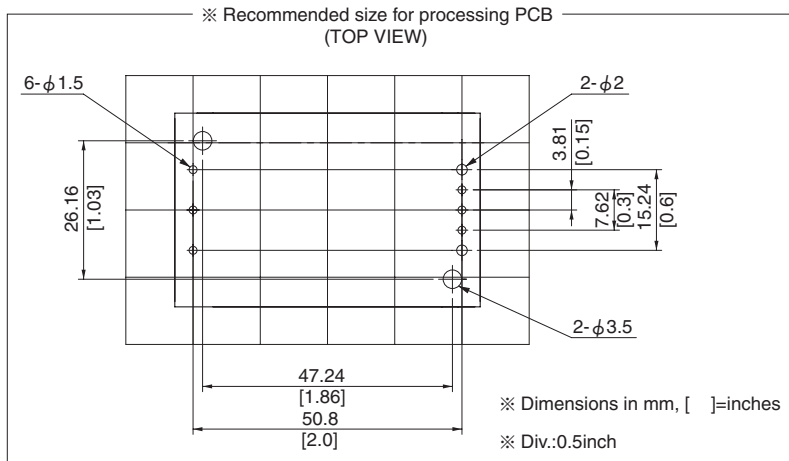
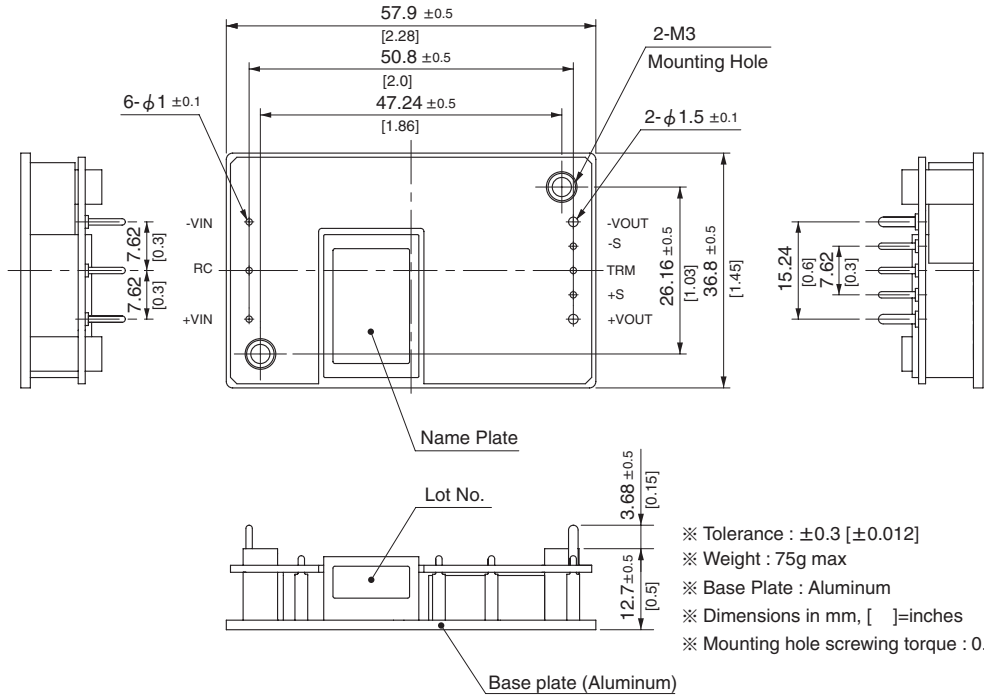

Pin Configuration

● CQHS250

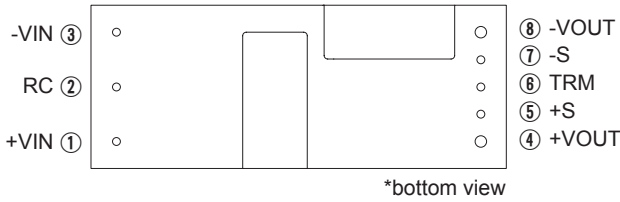

No.	Pin Name	Function
①	+VIN	+DC input
②	RC	Remote ON/OFF
③	-VIN	-DC input
④	+VOUT	+DC output
⑤	+S	+Remote sensing
⑥	TRM	Adjustment of output voltage
⑦	-S	-Remote sensing
⑧	-VOUT	-DC output
-	Mounting hole	Mounting hole

● CQHS300/CQHS350

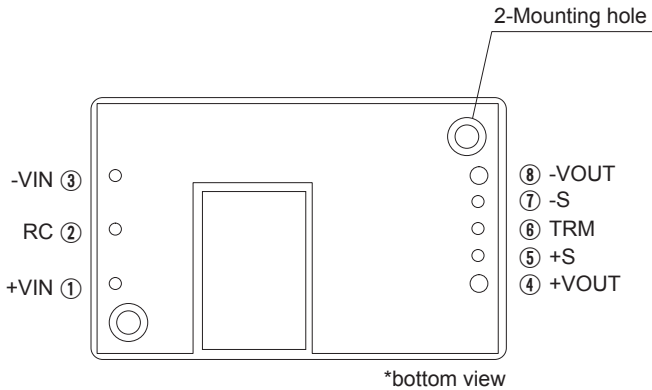

Implementation · Mounting Method

Mounting method

- When multiple power modules are used side by side, position them with sufficient spaces to allow adequate air ventilation so that the temperature of each power module will remain within the temperature range shown in the “Derating”.
- Do not pass the DC input pattern underneath the power module as this will increase conducted noise. Place the DC input pattern away from the power module. Do not pass the DC output pattern underneath the power module as this will increase output noise. Place the DC output pattern away from the power module.
- High frequency noise is radiated from the power module. When mounting the power module on a PCB, leave a copper pattern on the PCB to let it act as a shield and connect this pattern to the mounting hole.
- Avoid placing pattern layout in hatched area shown in right figure to insulate between pattern and power supply.

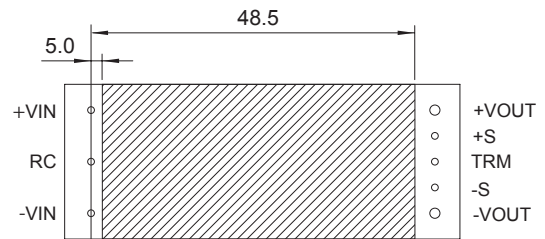

● CQHS300/CQHS350

- Soldering CQHS series with printed board must be done under the flat condition by using the mounting hole and fixing with the screw.
If CQHS series is inclined and it's mounted, the insulation of the internal components and printed board might not be kept.
- When a heat sink cannot be fixed on the base plate side, order the power module with “-T” option. A heat sink can be mounted by affixing a M3 tap on the heat sink.
Please make sure a mounting hole will be connected to a grounding capacitor CY.

	Mounting hole
Standard	M3 tapped
Optional : -T	φ 3.4 thru

Implementation · Mounting Method

Stress onto the pins

- Applying excessive stress to the input or output pins of the power module may damage internal connections. Avoid applying stress in excess of that shown in below.
- Input and output pins are soldered onto the internal PCB. Do not bend or pull the leads with excessive force.

●CQHS250

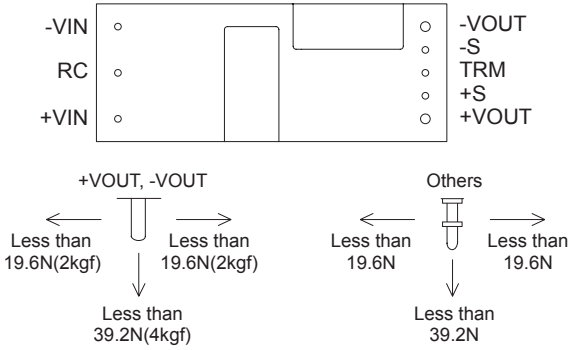

●CQHS300/CQHS350

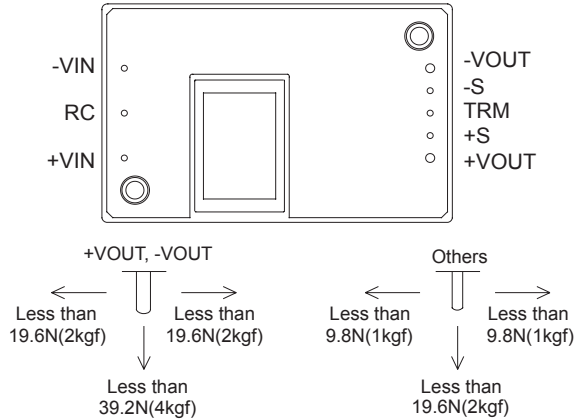

●CQHS300/CQHS350

- As unexpected stress may be applied to the pins, set the diameter of the PCB mounting hole at 3.5mm.
- As unexpected stress may be applied to the pins from vibration or shock, fix the power module by using the mounting holes screws to reduce stress.
- Fix the power module to the PCB with the screws before soldering the input and output pins to prevent the PCB pattern being damaged.

Soldering temperature

- Flow soldering : 260°C for up to 15 seconds.
- Soldering iron (26W) : 450°C for up to 5 seconds.

CQHS

Derating

- It is necessary to note the thermal fatigue life by power cycle. Please reduce the temperature fluctuation range as much as possible when the up and down of the temperature are frequently generated. Contact us for more information on cooling methods.

●CQHS250

- Use with the convection cooling or the forced air cooling. Make sure the temperatures at temperature measurement locations shown below are on or under the derating curve. Ambient temperature must be kept at 85°C or under.

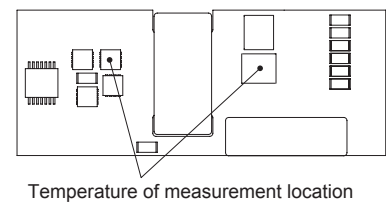
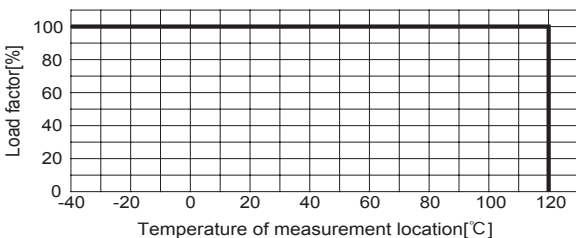

- For option “B” which is used with the convection cooling, forced air cooling or conduction cooling, use the temperature measurement location as shown in below.

Derating

① Vin=DC36-60V

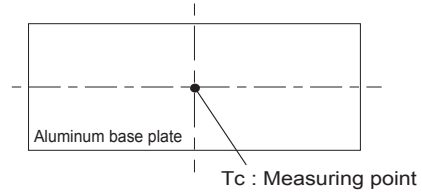
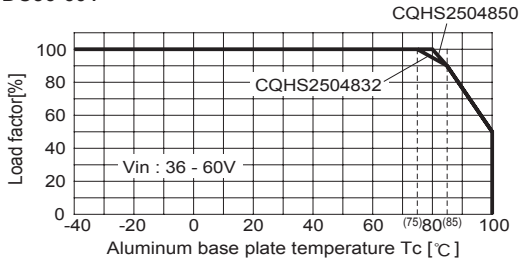

② Vin=DC60-76V

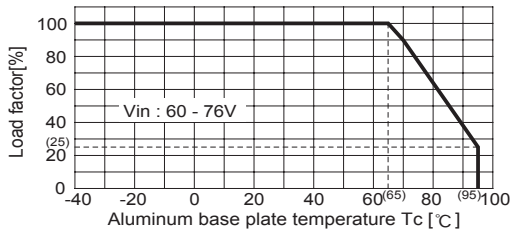

● CQHS300/CQHS350

■ Use the power modules with conduction cooling (e.g. heat dissipation from the aluminum base plate to the attached heat sink).

Below figure shows the derating curves with respect to the aluminum base plate temperature. Note that operation within the hatched areas will cause a significant level of ripple and ripple noise. Contact us for more information on cooling methods.

■ Please measure the temperature on the aluminum base plate edge side when you cannot measure the temperature of the center part of the aluminum base plate. In this case, please take 5deg temperature margin from the derating characteristic of below figure .

① Vin=DC36-60V

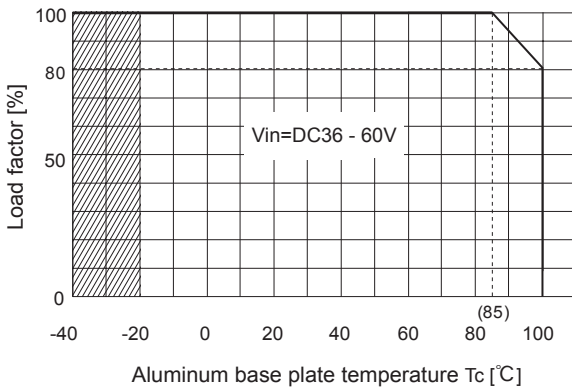

② CQHS300 : Vin=DC60 - 76V CQHS350 : Vin=DC60 - 65V

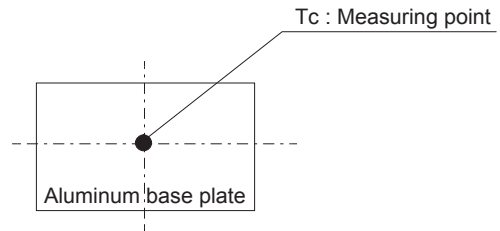
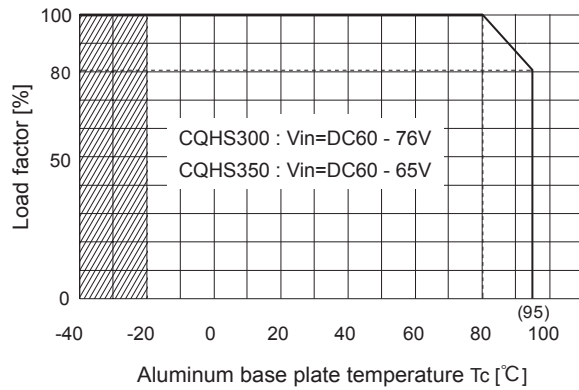

Instruction Manual

◆ It is necessary to read the "Instruction Manual" and "Before using our product" before you use our product.

Instruction Manual <https://www.cosel.co.jp/redirect/catalog/en/CQHS/>
 Before using our product <https://en.cosel.co.jp/technical/caution/index.html>

CQHS



NOTICE



Basic Characteristics Data

Model	Circuit method	Switching frequency [kHz]	Input current	Rated input fuse	Inrush current protection	PCB/Pattern			Series/Redundancy operation availability	
						Material	Single sided	Double sided	Series operation	Redundancy operation
CQHS250	Full-bridge converter	140	*1	-	-	glass fabric base, epoxy resin		Multilayer	Yes	*2
CQHS300	Forward converter	250	*1	-	-	Aluminum	Yes		Yes	*2
CQHS350	Forward converter	250	*1	-	-	Aluminum	Yes		Yes	*2

*1 Refer to Specification.

*2 Refer to Instruction Manual.



DHS-series

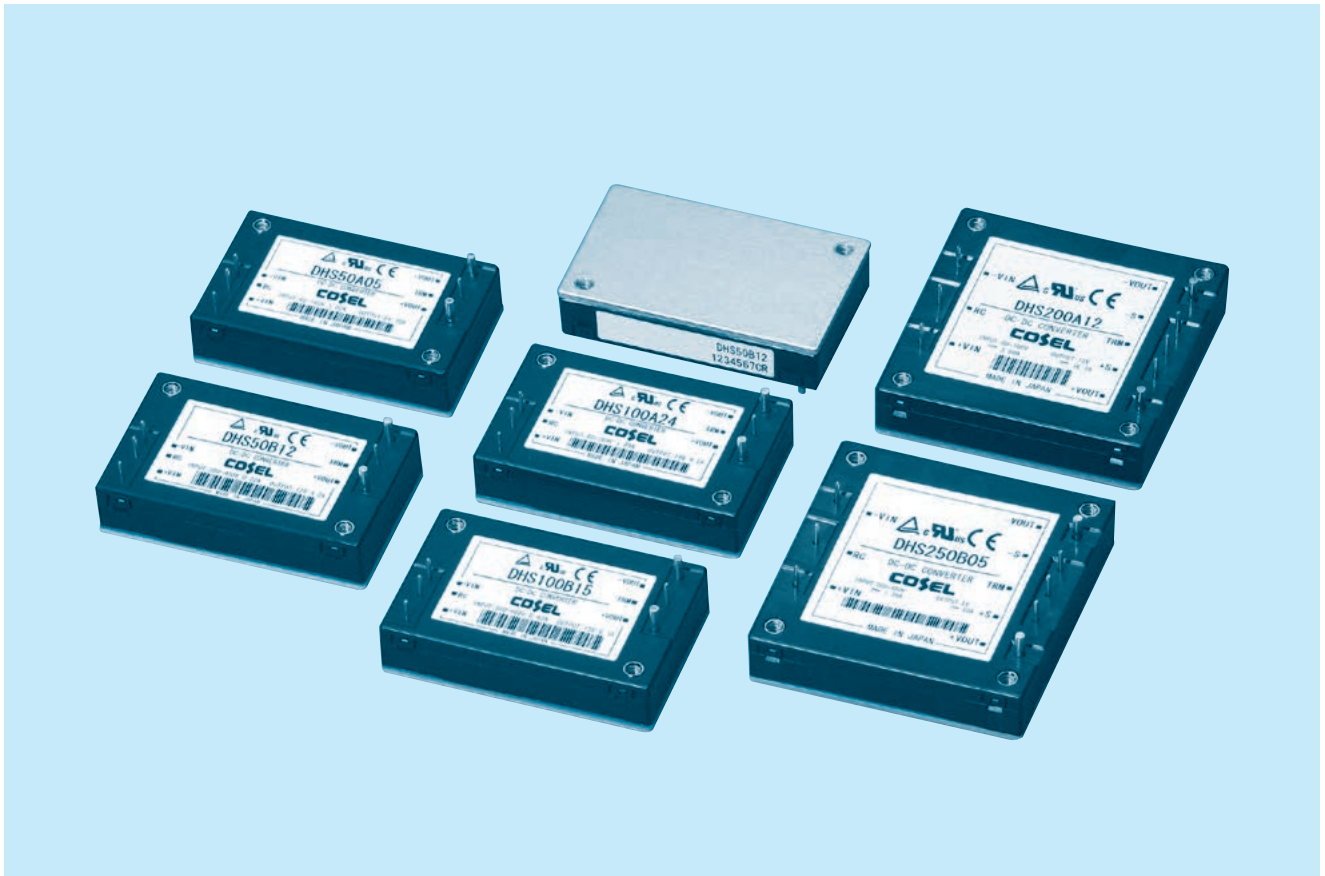

DHS

■ Feature

- Ideal for distributed power systems
- Thin and small size
- Built-in overcurrent, overvoltage and thermal protection circuits
- Built-in remote ON/OFF
- Mounting hole (M3 tapped)

■ CE marking

- Low Voltage Directive
- RoHS Directive

■ UKCA marking

- Electrical Equipment Safety Regulations
- RoHS Regulations

■ Safety agency approvals

- UL60950-1, C-UL, EN62368-1

■ 5-year warranty

■ Optional parts

- Heat sink

DHS50A

DH S 50 A 05 -□

① ② ③ ④ ⑤ ⑥



RoHS

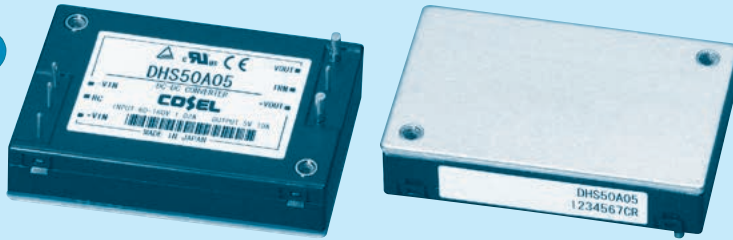

*Providing heat sink as option

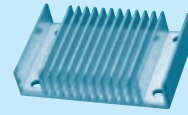

- ① Series name
- ② Single output
- ③ Output wattage
- ④ A : DC60-160V
- ⑤ Output voltage
- ⑥ Optional
- T : with Mounting hole (φ 3.4 thru)

MODEL	DHS50A05	DHS50A12	DHS50A15	DHS50A24
MAX OUTPUT WATTAGE[W]	50.0	50.4	51.0	50.4
DC OUTPUT	5V 10A	12V 4.2A	15V 3.4A	24V 2.1A

SPECIFICATIONS

	MODEL	DHS50A05	DHS50A12	DHS50A15	DHS50A24	
INPUT	VOLTAGE[V]	DC60 - 160				
	CURRENT[A]	0.55A	0.55A	0.55A	0.55A	
	EFFICIENCY[%]	84.0typ	86.0typ	86.0typ	86.0typ	
OUTPUT	VOLTAGE[V]	5	12	15	24	
	CURRENT[A]	10	4.2	3.4	2.1	
	LINE REGULATION[mV]	10max	24max	30max	48max	
	LOAD REGULATION[mV]	10max	24max	30max	48max	
	RIPPLE[mVp-p]	0 to +100°C*2	80max	120max	120max	120max
		-40 to 0°C*2	120max	150max	150max	150max
		0 to 15% Load*2	160max	240max	240max	240max
	RIPPLE NOISE[mVp-p]	0 to +100°C*2	120max	150max	150max	150max
		-40 to 0°C*2	200max	200max	200max	250max
		0 to 15% Load*2	240max	300max	300max	300max
	TEMPERATURE REGULATION[mV]	0 to +65°C	50max	120max	150max	240max
		-40 to +100°C	100max	240max	300max	480max
	DRIFT[mV]	*3	20max	40max	60max	90max
START-UP TIME[ms]	200max (DCIN 110V, Io=100%)					
OUTPUT VOLTAGE ADJUSTMENT RANGE[V]	*4 Fixed (TRM pin open), adjustable by external VR or external voltage					
	4.50 - 6.00	10.80 - 13.20	13.50 - 16.50	21.60 - 26.40		
OUTPUT VOLTAGE SETTING[V]	4.97 - 5.13	11.91 - 12.29	14.76 - 15.24	23.62 - 24.38		
PROTECTION CIRCUIT AND OTHERS	OVERCURRENT PROTECTION	Works over 105% of rating and recovers automatically				
	OVERVOLTAGE PROTECTION[V]	6.30 - 7.60	13.90 - 17.55	17.25 - 21.75	27.60 - 34.80	
	REMOTE SENSING	nothing				
REMOTE ON/OFF	Provided (Negative Logic L : ON, H :OFF)					
ISOLATION	INPUT-OUTPUT	AC3,000V 1minute, Cutoff current = 10mA, DC500V 50MΩ min (20±15°C)				
	INPUT-FG	AC2,000V 1minute, Cutoff current = 10mA, DC500V 50MΩ min (20±15°C)				
	OUTPUT-FG	AC500V 1minute, Cutoff current = 100mA, DC500V 50MΩ min (20±15°C)				
ENVIRONMENT	OPERATING TEMP.,HUMID.AND ALTIITUDE	-40 to +100°C (On aluminum base plate), 20 - 95%RH (Non condensing) (Refer to "Derating"), 3,000m (10,000 feet) max				
	STORAGE TEMP.,HUMID.AND ALTIITUDE	-40 to +100°C, 20 - 95%RH (Non condensing), 9,000m (30,000 feet) max				
	VIBRATION	10 - 55Hz, 49.0m/s² (5G), 3minutes period, 60minutes each along X, Y and Z axis Complies with IEC61373 Category 1 Class B				
	IMPACT	196.1m/s² (20G), 11ms, once each along X, Y and Z axis Complies with IEC61373 Category 1 Class B				
SAFETY	AGENCY APPROVALS	UL60950-1, C-UL (CSA60950-1), EN62368-1				
OTHERS	CASE SIZE/WEIGHT	58.4 X 12.7 X 37.3mm [2.3 X 0.5 X 1.47 inches] (W X H X D) / 60g max				
	COOLING METHOD	Conduction cooling (e.g. heat radiation from the aluminum base plate to the attached heat sink)				

*1 At rated input(DC110V) and rated load.

*2 Ripple and ripple noise is measured by using measuring board. Refer to the manual

*3 Drift is the change in DC output for an eight hour period after a half-hour warm-up at 25°C, with the input voltage held constant at the rated input/output.

*4 Refer to the manual for input range.

External view

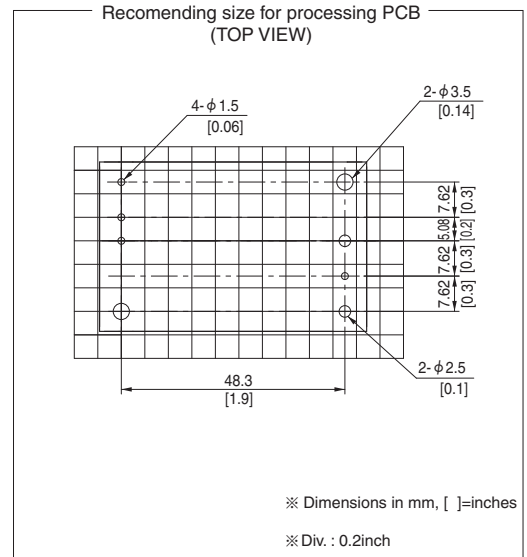
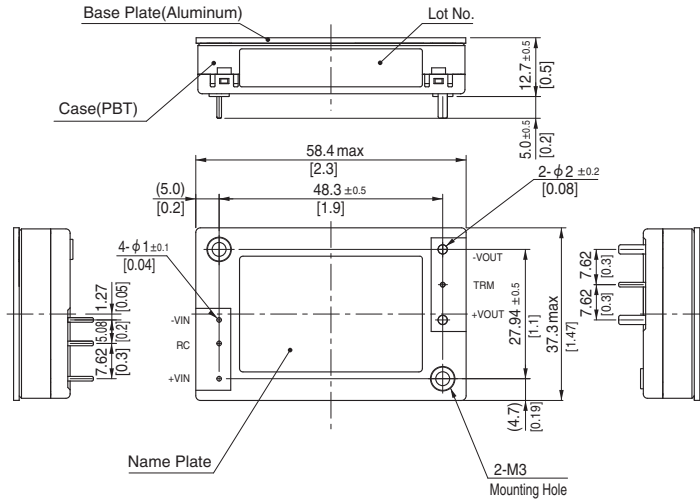

※ Dimensions in mm, []=inches
 ※ Div. : 0.2inch

- ※ Tolerance : ± 0.3 [± 0.012]
- ※ Weight : 60g max
- ※ Dimensions in mm, []=inches
- ※ Mounting hole screwing torque : $0.49N \cdot m$ (5.0kgf · cm) max

DHS100A

DH S 100 A 05 -□

① ② ③ ④ ⑤ ⑥



RoHS

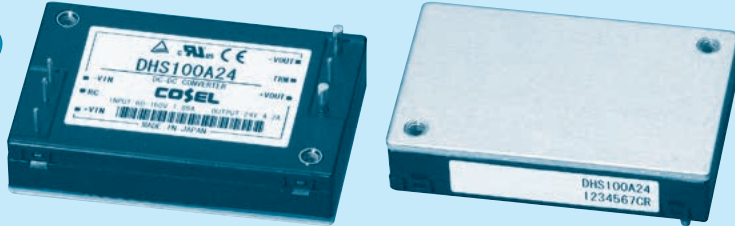

*Providing heat sink as option

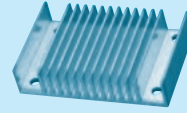

- ① Series name
- ② Single output
- ③ Output wattage
- ④ A : DC60-160V
- ⑤ Output voltage
- ⑥ Optional
- T : with Mounting hole (φ 3.4 thru)

MODEL	DHS100A05	DHS100A12	DHS100A15	DHS100A24
MAX OUTPUT WATTAGE[W]	100.0	100.8	100.5	100.8
DC OUTPUT	5V 20A	12V 8.4A	15V 6.7A	24V 4.2A

SPECIFICATIONS

	MODEL	DHS100A05	DHS100A12	DHS100A15	DHS100A24	
INPUT	VOLTAGE[V]	DC60 - 160				
	CURRENT[A]	1.1A	1.1A	1.1A	1.1A	
	EFFICIENCY[%]	85.0typ	88.0typ	88.0typ	88.0typ	
OUTPUT	VOLTAGE[V]	5	12	15	24	
	CURRENT[A]	20	8.4	6.7	4.2	
	LINE REGULATION[mV]	10max	24max	30max	48max	
	LOAD REGULATION[mV]	10max	24max	30max	48max	
	RIPPLE[mVp-p]	0 to +100°C *2	80max	120max	120max	120max
		-40 to 0°C *2	120max	150max	150max	150max
		0 to 15% Load *2	160max	240max	240max	240max
	RIPPLE NOISE[mVp-p]	0 to +100°C *2	120max	150max	150max	150max
		-40 to 0°C *2	200max	200max	200max	250max
		0 to 15% Load *2	240max	300max	300max	300max
	TEMPERATURE REGULATION[mV]	0 to +65°C	50max	120max	150max	240max
		-40 to +100°C	100max	240max	300max	480max
	DRIFT[mV]	*3	20max	40max	60max	90max
START-UP TIME[ms]	200max (DCIN 110V, Io=100%)					
OUTPUT VOLTAGE ADJUSTMENT RANGE[V]	*4 Fixed (TRM pin open), adjustable by external VR or external voltage					
OUTPUT VOLTAGE SETTING[V]	4.50 - 6.00	10.80 - 13.20	13.50 - 16.50	21.60 - 26.40		
	4.97 - 5.13	11.91 - 12.29	14.76 - 15.24	23.62 - 24.38		
PROTECTION CIRCUIT AND OTHERS	OVERCURRENT PROTECTION	Works over 105% of rating and recovers automatically				
	OVERVOLTAGE PROTECTION[V]	6.30 - 7.60	13.90 - 17.55	17.25 - 21.75	27.60 - 34.80	
	REMOTE SENSING	nothing				
REMOTE ON/OFF	Provided (Negative Logic L : ON, H :OFF)					
ISOLATION	INPUT-OUTPUT	AC3,000V 1minute, Cutoff current = 10mA, DC500V 50MΩ min (20±15°C)				
	INPUT-FG	AC2,000V 1minute, Cutoff current = 10mA, DC500V 50MΩ min (20±15°C)				
	OUTPUT-FG	AC500V 1minute, Cutoff current = 100mA, DC500V 50MΩ min (20±15°C)				
ENVIRONMENT	OPERATING TEMP.,HUMID.AND ALTIUDE	-40 to +100°C (On aluminum base plate), 20 - 95%RH (Non condensing) (Refer to "Derating"), 3,000m (10,000 feet) max				
	STORAGE TEMP.,HUMID.AND ALTIUDE	-40 to +100°C, 20 - 95%RH (Non condensing), 9,000m (30,000 feet) max				
	VIBRATION	10 - 55Hz, 49.0m/s² (5G), 3minutes period, 60minutes each along X, Y and Z axis Complies with IEC61373 Category 1 Class B				
	IMPACT	196.1m/s² (20G), 11ms, once each along X, Y and Z axis Complies with IEC61373 Category 1 Class B				
SAFETY	AGENCY APPROVALS	UL60950-1, C-UL (CSA60950-1), EN62368-1				
OTHERS	CASE SIZE/WEIGHT	58.4 X 12.7 X 37.3mm [2.3 X 0.5 X 1.47 inches] (W X H X D) / 60g max				
	COOLING METHOD	Conduction cooling (e.g. heat radiation from the aluminum base plate to the attached heat sink)				

*1 At rated input(DC110V) and rated load.
 *2 Ripple and ripple noise is measured by using measuring board. Refer to the manual.
 *3 Drift is the change in DC output for an eight hour period after a half-hour warm-up at 25°C, with the input voltage held constant at the rated input/output.
 *4 Refer to the manual for input range.

External view

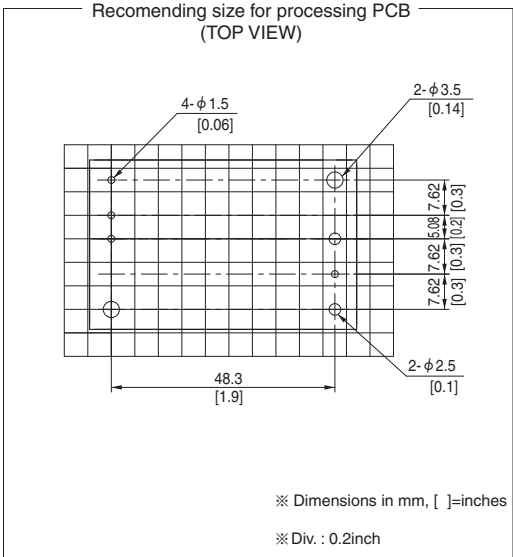
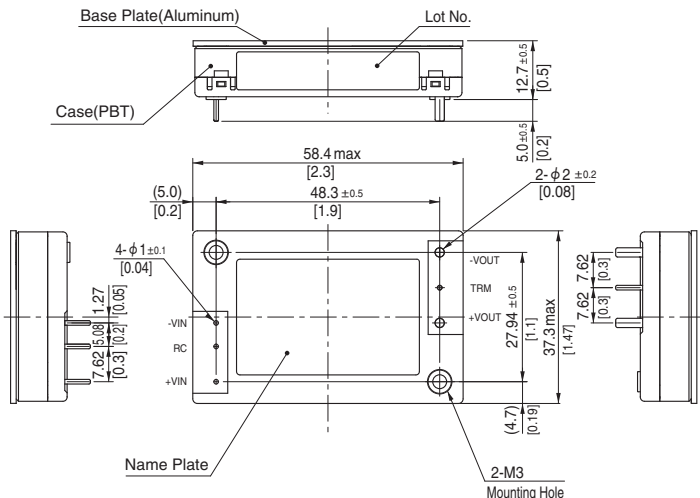

※ Dimensions in mm, []=inches
 ※ Div. : 0.2inch

- ※ Tolerance : ±0.3 [±0.012]
- ※ Weight : 60g max
- ※ Dimensions in mm, []=inches
- ※ Mounting hole screwing torque : 0.49N · m (5.0kgf · cm) max

DHS200A

DH S 200 A 05 -□

① ② ③ ④ ⑤ ⑥



*Providing heat sink as option

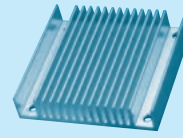

- ① Series name
- ② Single output
- ③ Output wattage
- ④ A : DC60-160V
- ⑤ Output voltage
- ⑥ Optional
T : with Mounting hole (φ 3.4 thru)

MODEL	DHS200A05	DHS200A12	DHS200A15	DHS200A24
MAX OUTPUT WATTAGE[W]	200.0	200.4	201.0	201.6
DC OUTPUT	5V 40A	12V 16.7A	15V 13.4A	24V 8.4A

SPECIFICATIONS

	MODEL	DHS200A05	DHS200A12	DHS200A15	DHS200A24	
INPUT	VOLTAGE[V]	DC60 - 160				
	CURRENT[A]	2.1A	2.1A	2.1A	2.1A	
	EFFICIENCY[%]	87.0typ	88.0typ	88.0typ	88.0typ	
OUTPUT	VOLTAGE[V]	5	12	15	24	
	CURRENT[A]	40	16.7	13.4	8.4	
	LINE REGULATION[mV]	10max	24max	30max	48max	
	LOAD REGULATION[mV]	10max	24max	30max	48max	
	RIPPLE[mVp-p]	0 to +100°C*2	80max	120max	120max	120max
		-40 to 0°C *2	120max	150max	150max	150max
		0 to 15% Load*2	160max	240max	240max	240max
	RIPPLE NOISE[mVp-p]	0 to +100°C*2	120max	150max	150max	150max
		-40 to 0°C *2	200max	200max	200max	250max
		0 to 15% Load*2	240max	300max	300max	300max
	TEMPERATURE REGULATION[mV]	0 to +65°C	50max	120max	150max	240max
		-40 to +100°C	100max	240max	300max	480max
	DRIFT[mV]	*3	20max	40max	60max	90max
START-UP TIME[ms]	200max (DCIN 110V, Io=100%)					
OUTPUT VOLTAGE ADJUSTMENT RANGE[V]	*4	Fixed (TRM pin open), adjustable by external VR or external voltage				
		3.00 - 6.00	7.20 - 13.20	9.00 - 16.50	14.40 - 26.40	
OUTPUT VOLTAGE SETTING[V]		4.97 - 5.13	11.91 - 12.29	14.76 - 15.24	23.62 - 24.38	
PROTECTION CIRCUIT AND OTHERS	OVERCURRENT PROTECTION	Works over 105% of rating and recovers automatically				
	OVERVOLTAGE PROTECTION[V]	6.30 - 7.30	13.90 - 16.35	17.25 - 20.25	27.60 - 32.40	
	REMOTE SENSING	Provided				
REMOTE ON/OFF	Provided (Negative Logic L : ON, H :OFF)					
ISOLATION	INPUT-OUTPUT	AC3,000V 1minute, Cutoff current = 10mA, DC500V 50MΩ min (20±15°C)				
	INPUT-FG	AC2,000V 1minute, Cutoff current = 10mA, DC500V 50MΩ min (20±15°C)				
	OUTPUT-FG	AC500V 1minute, Cutoff current = 100mA, DC500V 50MΩ min (20±15°C)				
ENVIRONMENT	OPERATING TEMP.,HUMID.AND ALTIITUDE	-40 to +100°C (On aluminum base plate), 20 - 95%RH (Non condensing) (Refer to "Derating"), 3,000m (10,000 feet) max				
	STORAGE TEMP.,HUMID.AND ALTIITUDE	-40 to +100°C, 20 - 95%RH (Non condensing), 9,000m (30,000 feet) max				
	VIBRATION	10 - 55Hz, 49.0m/s ² (5G), 3minutes period, 60minutes each along X, Y and Z axis Complies with IEC61373 Category 1 Class B				
	IMPACT	196.1m/s ² (20G), 11ms, once each along X, Y and Z axis Complies with IEC61373 Category 1 Class B				
SAFETY	AGENCY APPROVALS	UL60950-1, C-UL (CSA60950-1), EN62368-1				
OTHERS	CASE SIZE/WEIGHT	58.4 × 12.7 × 61mm [2.3 × 0.5 × 2.4 inches] (W × H × D) / 100g max				
	COOLING METHOD	Conduction cooling (e.g. heat radiation from the aluminum base plate to the attached heat sink)				

*1 At rated input(DC110V) and rated load.
 *2 Ripple and ripple noise is measured by using measuring board. Refer to the manual.
 *3 Drift is the change in DC output for an eight hour period after a half-hour warm-up at 25°C, with the input voltage held constant at the rated input/output.
 *4 Refer to the manual for input range.

External view

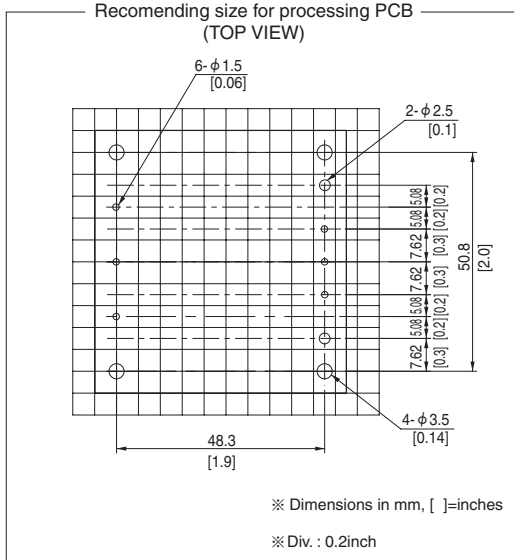
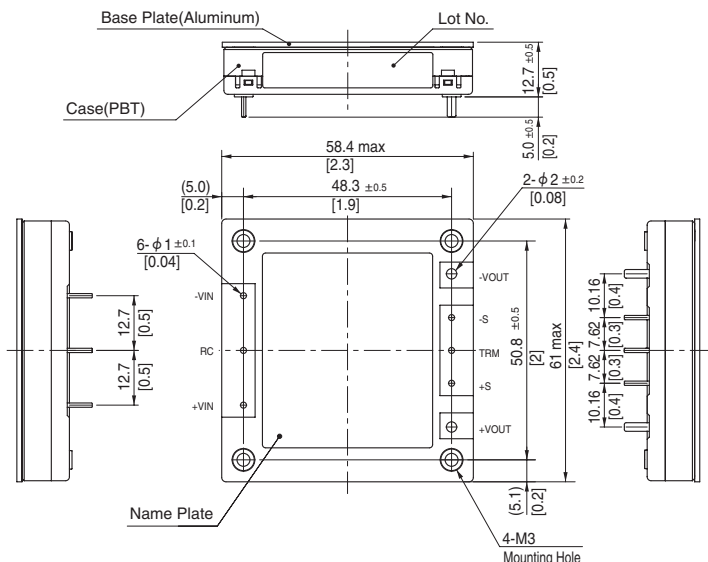

- ※ Dimensions in mm, []=inches
- ※ Div. : 0.2inch
- ※ Tolerance : ±0.3 [±0.012]
- ※ Weight : 100g max
- ※ Dimensions in mm, []=inches
- ※ Mounting hole screwing torque : 0.49N · m (5.0kgf · cm) max

DHS50B

DH S 50 B 05 -□

① ② ③ ④ ⑤ ⑥



RoHS



*Providing heat sink as option

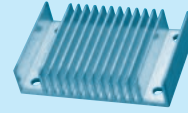

- ① Series name
- ② Single output
- ③ Output wattage
- ④ B : DC200-400V
- ⑤ Output voltage
- ⑥ Optional
T : with Mounting hole (φ 3.4 thru)

MODEL	DHS50B03	DHS50B05	DHS50B12	DHS50B15	DHS50B24	DHS50B28
MAX OUTPUT WATTAGE[W]	33.0	50.0	50.4	51.0	50.4	50.4
DC OUTPUT	3.3V 10A	5V 10A	12V 4.2A	15V 3.4A	24V 2.1A	28V 1.8A

SPECIFICATIONS

	MODEL	DHS50B03	DHS50B05	DHS50B12	DHS50B15	DHS50B24	DHS50B28	
INPUT	VOLTAGE[V]	DC200 - 400						
	CURRENT[A]	*1 0.15A	0.22A	0.22A	0.22A	0.22A	0.22A	
	EFFICIENCY[%]	*1 77.0typ	80.0typ	83.0typ	83.0typ	83.0typ	82.0typ	
OUTPUT	VOLTAGE[V]	3.3	5	12	15	24	28	
	CURRENT[A]	10	10	4.2	3.4	2.1	1.8	
	LINE REGULATION[mV]	10max	10max	24max	30max	48max	56max	
	LOAD REGULATION[mV]	10max	10max	24max	30max	48max	56max	
	RIPPLE[mVp-p]	0 to +100°C *2	80max	80max	120max	120max	120max	120max
		-40 to 0°C *2	120max	120max	150max	150max	150max	150max
		0 to 15% Load *2	160max	160max	240max	240max	240max	240max
	RIPPLE NOISE[mVp-p]	0 to +100°C *2	120max	120max	150max	150max	150max	150max
		-40 to 0°C *2	200max	200max	200max	200max	250max	250max
		0 to 15% Load *2	240max	240max	300max	300max	300max	300max
	TEMPERATURE REGULATION[mV]	0 to +65°C	35max	50max	120max	150max	240max	280max
		-40 to +100°C	66max	100max	240max	300max	480max	560max
	DRIFT[mV]	*3	16max	20max	40max	60max	90max	90max
	START-UP TIME[ms]		200max (DCIN 280V, Io=100%)					
OUTPUT VOLTAGE ADJUSTMENT RANGE[V]	*4	Fixed (TRM pin open), adjustable by external VR or external voltage						
		2.97 - 3.96	4.50 - 6.00	10.80 - 13.20	13.50 - 16.50	21.60 - 26.40	25.20 - 30.80	
OUTPUT VOLTAGE SETTING[V]		3.30 - 3.40	4.97 - 5.13	11.91 - 12.29	14.76 - 15.24	23.62 - 24.38	27.56 - 28.44	
PROTECTION CIRCUIT AND OTHERS	OVERCURRENT PROTECTION	Works over 105% of rating and recovers automatically						
	OVERVOLTAGE PROTECTION[V]	4.20 - 5.70	6.30 - 7.60	13.90 - 17.55	17.25 - 21.75	27.60 - 34.80	32.20 - 40.60	
	REMOTE SENSING	None						
	REMOTE ON/OFF	Provided (Negative Logic L : ON, H :OFF)						
ISOLATION	INPUT-OUTPUT	AC3,000V 1minute, Cutoff current = 10mA, DC500V 50MΩ min (20±15°C)						
	INPUT-FG	AC2,000V 1minute, Cutoff current = 10mA, DC500V 50MΩ min (20±15°C)						
	OUTPUT-FG	AC500V 1minute, Cutoff current = 100mA, DC500V 50MΩ min (20±15°C)						
ENVIRONMENT	OPERATING TEMP., HUMID. AND ALTITUDE	-40 to +100°C (On aluminum base plate), 20 - 95%RH (Non condensing) (Refer to "Derating"), 3,000m (10,000 feet) max						
	STORAGE TEMP., HUMID. AND ALTITUDE	-40 to +100°C, 20 - 95%RH (Non condensing), 9,000m (30,000 feet) max						
	VIBRATION	10 - 55Hz, 49.0m/s ² (5G), 3minutes period, 60minutes each along X, Y and Z axis						
	IMPACT	196.1m/s ² (20G), 11ms, once each along X, Y and Z axis						
SAFETY	AGENCY APPROVALS	UL60950-1, C-UL, EN62368-1						
OTHERS	CASE SIZE/WEIGHT	58.4 × 12.7 × 37.3mm [2.3 × 0.5 × 1.47 inches] (W × H × D) / 60g max						
	COOLING METHOD	Conduction cooling (e.g. heat radiation from the aluminum base plate to the attached heat sink)						

*1 At rated input(DC280V) and rated load.
 *2 Ripple and ripple noise is measured by using measuring board. Refer to the manual
 *3 Drift is the change in DC output for an eight hour period after a half-hour warm-up at 25°C, with the input voltage held constant at the rated input/output.
 *4 Refer to the manual for input range.

External view

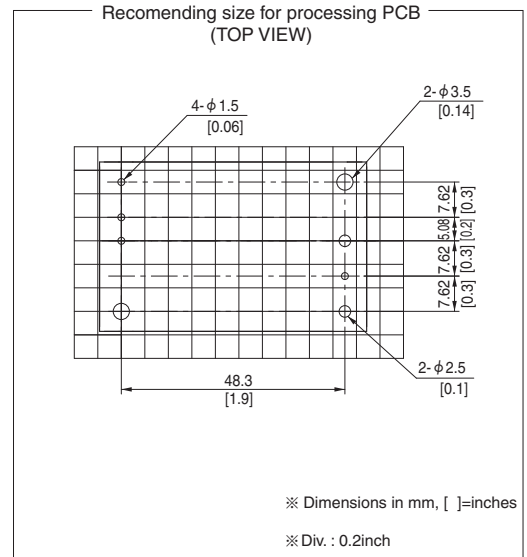
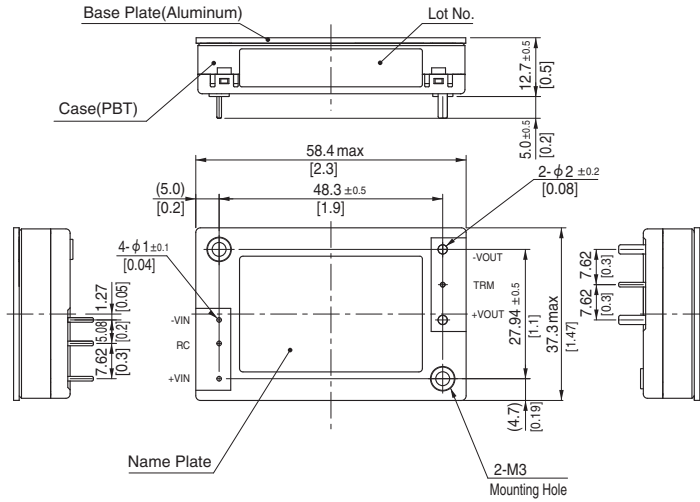

- ※ Tolerance : ± 0.3 [± 0.012]
- ※ Weight : 60g max
- ※ Dimensions in mm, []=inches
- ※ Mounting hole screwing torque : $0.49N \cdot m$ (5.0kgf · cm) max

DHS100B

DH S 100 B 05 -□

① ② ③ ④ ⑤ ⑥



RoHS

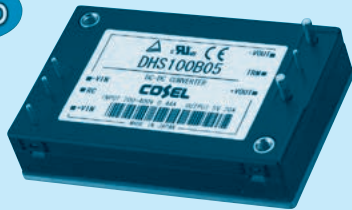

*Providing heat sink as option

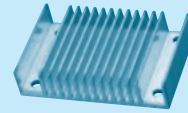

- ① Series name
- ② Single output
- ③ Output wattage
- ④ B : DC200-400V
- ⑤ Output voltage
- ⑥ Optional
T : with Mounting hole (φ 3.4 thru)

MODEL	DHS100B03	DHS100B05	DHS100B12	DHS100B15	DHS100B24	DHS100B28
MAX OUTPUT WATTAGE[W]	66.0	100.0	100.8	100.5	100.8	100.8
DC OUTPUT	3.3V 20A	5V 20A	12V 8.4A	15V 6.7A	24V 4.2A	28V 3.6A

SPECIFICATIONS

	MODEL	DHS100B03	DHS100B05	DHS100B12	DHS100B15	DHS100B24	DHS100B28	
INPUT	VOLTAGE[V]	DC200 - 400						
	CURRENT[A]	0.30A	0.44A	0.42A	0.42A	0.42A	0.42A	
	EFFICIENCY[%]	79.0typ	82.0typ	85.0typ	86.0typ	86.0typ	86.0typ	
OUTPUT	VOLTAGE[V]	3.3	5	12	15	24	28	
	CURRENT[A]	20	20	8.4	6.7	4.2	3.6	
	LINE REGULATION[mV]	10max	10max	24max	30max	48max	56max	
	LOAD REGULATION[mV]	10max	10max	24max	30max	48max	56max	
	RIPPLE[mVp-p]	0 to +100°C*2	80max	80max	120max	120max	120max	120max
		-40 to 0°C *2	120max	120max	150max	150max	150max	150max
		0 to 15% Load*2	160max	160max	240max	240max	240max	240max
	RIPPLE NOISE[mVp-p]	0 to +100°C*2	120max	120max	150max	150max	150max	150max
		-40 to 0°C *2	200max	200max	200max	200max	250max	250max
		0 to 15% Load*2	240max	240max	300max	300max	300max	300max
	TEMPERATURE REGULATION[mV]	0 to +65°C	35max	50max	120max	150max	240max	280max
		-40 to +100°C	66max	100max	240max	300max	480max	560max
	DRIFT[mV]	16max	20max	40max	60max	90max	90max	
START-UP TIME[ms]	200max (DCIN 280V, Io=100%)							
OUTPUT VOLTAGE ADJUSTMENT RANGE[V]	Fixed (TRM pin open), adjustable by external VR or external voltage							
	2.97 - 3.96	4.50 - 6.00	10.80 - 13.20	13.50 - 16.50	21.60 - 26.40	25.20 - 30.80		
	3.30 - 3.40	4.97 - 5.13	11.91 - 12.29	14.76 - 15.24	23.62 - 24.38	27.56 - 28.44		
OUTPUT VOLTAGE SETTING[V]	3.30 - 3.40	4.97 - 5.13	11.91 - 12.29	14.76 - 15.24	23.62 - 24.38	27.56 - 28.44		
PROTECTION CIRCUIT AND OTHERS	OVERCURRENT PROTECTION	Works over 105% of rating and recovers automatically						
	OVERVOLTAGE PROTECTION[V]	4.20 - 5.70	6.30 - 7.60	13.90 - 17.55	17.25 - 21.75	27.60 - 34.80	32.20 - 40.60	
	REMOTE SENSING	None						
	REMOTE ON/OFF	Provided (Negative Logic L : ON, H :OFF)						
ISOLATION	INPUT-OUTPUT	AC3,000V 1minute, Cutoff current = 10mA, DC500V 50MΩ min (20±15°C)						
	INPUT-FG	AC2,000V 1minute, Cutoff current = 10mA, DC500V 50MΩ min (20±15°C)						
	OUTPUT-FG	AC500V 1minute, Cutoff current = 100mA, DC500V 50MΩ min (20±15°C)						
ENVIRONMENT	OPERATING TEMP.,HUMID.AND ALTIUDE	-40 to +100°C (On aluminum base plate), 20 - 95%RH (Non condensing) (Refer to "Derating"), 3,000m (10,000 feet) max						
	STORAGE TEMP.,HUMID.AND ALTIUDE	-40 to +100°C, 20 - 95%RH (Non condensing), 9,000m (30,000 feet) max						
	VIBRATION	10 - 55Hz, 49.0m/s ² (5G), 3minutes period, 60minutes each along X, Y and Z axis						
	IMPACT	196.1m/s ² (20G), 11ms, once each along X, Y and Z axis						
SAFETY	AGENCY APPROVALS	UL60950-1, C-UL, EN62368-1						
OTHERS	CASE SIZE/WEIGHT	58.4 X 12.7 X 37.3mm [2.3 X 0.5 X 1.47 inches] (W X H X D) / 60g max						
	COOLING METHOD	Conduction cooling (e.g. heat radiation from the aluminum base plate to the attached heat sink)						

*1 At rated input(DC280V) and rated load.
 *2 Ripple and ripple noise is measured by using measuring board. Refer to the manual.
 *3 Drift is the change in DC output for an eight hour period after a half-hour warm-up at 25°C, with the input voltage held constant at the rated input/output.
 *4 Refer to the manual for input range.

External view

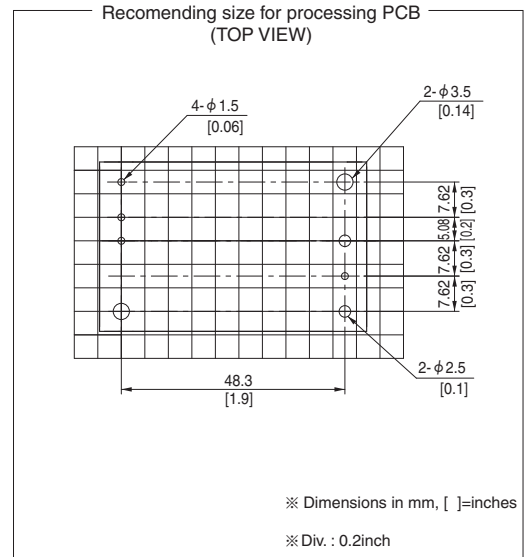
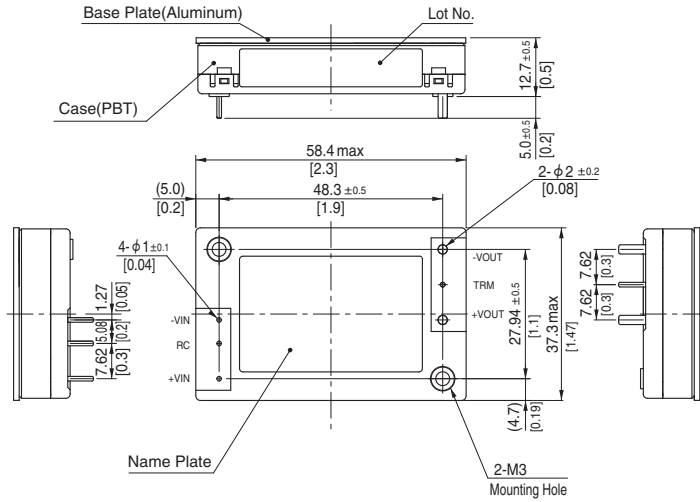

- ※ Tolerance : ± 0.3 [± 0.012]
- ※ Weight : 60g max
- ※ Dimensions in mm, []=inches
- ※ Mounting hole screwing torque : $0.49N \cdot m$ (5.0kgf · cm) max

DHS250B

DH S 250 B 05 -□

① ② ③ ④ ⑤ ⑥



RoHS

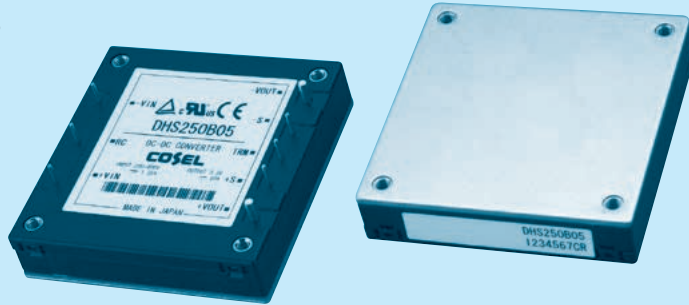

*Providing heat sink as option

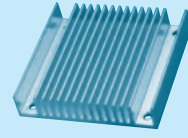

- ① Series name
- ② Single output
- ③ Output wattage
- ④ B : DC200-400V
- ⑤ Output voltage
- ⑥ Optional
- T : with Mounting hole (φ 3.4 thru)

MODEL	DHS250B03	DHS250B05	DHS250B07	DHS250B12	DHS250B15	DHS250B24	DHS250B28	DHS250B48
MAX OUTPUT WATTAGE[W]	165.0	250.0	247.5	252.0	247.5	252.0	252.0	249.6
DC OUTPUT	3.3V 50A	5V 50A	7.5V 33A	12V 21A	15V 16.5A	24V 10.5A	28V 9.0A	48V 5.2A

SPECIFICATIONS

	MODEL	DHS250B03	DHS250B05	DHS250B07	DHS250B12	DHS250B15	DHS250B24	DHS250B28	DHS250B48	
INPUT	VOLTAGE[V]	DC200 - 400								
	CURRENT[A]	0.67A	1.0A	1.0A	1.0A	1.0A	1.0A	1.0A	1.0A	
	EFFICIENCY[%]	88.0typ	90.0typ	88.0typ	88.0typ	88.0typ	88.0typ	88.0typ	89.0typ	
OUTPUT	VOLTAGE[V]	3.3	5	7.5	12	15	24	28	48	
	CURRENT[A]	50	50	33	21	16.5	10.5	9.0	5.2	
	LINE REGULATION[mV]	10max	10max	20max	24max	30max	48max	56max	96max	
	LOAD REGULATION[mV]	10max	10max	20max	24max	30max	48max	56max	96max	
	RIPPLE[mVp-p]	0 to +100°C*	80max	80max	100max	120max	120max	120max	120max	200max
		-40 to 0°C *	120max	120max	130max	150max	150max	150max	150max	250max
		0 to 15% Load*	160max	160max	200max	240max	240max	240max	240max	400max
	RIPPLE NOISE[mVp-p]	0 to +100°C*	120max	120max	130max	150max	150max	150max	150max	250max
		-40 to 0°C *	200max	200max	200max	200max	200max	250max	250max	400max
		0 to 15% Load*	240max	240max	260max	300max	300max	300max	300max	500max
	TEMPERATURE REGULATION[mV]	0 to +65°C	35max	50max	70max	120max	150max	240max	280max	480max
		-40 to +100°C	66max	100max	140max	240max	300max	480max	560max	960max
	DRIFT[mV]	16max	20max	30max	40max	60max	90max	90max	180max	
START-UP TIME[ms]	200max (DCIN 280V, Io=100%)									
OUTPUT VOLTAGE ADJUSTMENT RANGE[V]	Fixed (TRM pin open), adjustable by external VR or external voltage									
	1.98 - 3.96	3.00 - 6.00	4.50 - 8.25	7.20 - 13.20	9.00 - 16.50	14.40 - 26.40	16.80 - 30.80	28.80 - 52.80		
OUTPUT VOLTAGE SETTING[V]	3.30 - 3.40	4.97 - 5.13	7.43 - 7.67	11.91 - 12.29	14.76 - 15.24	23.62 - 24.38	27.56 - 28.44	47.24 - 48.76		
PROTECTION CIRCUIT AND OTHERS	OVERCURRENT PROTECTION	Works over 105% of rating and recovers automatically								
	OVERVOLTAGE PROTECTION[V]	4.20 - 4.85	6.30 - 7.30	8.70 - 10.20	13.90 - 16.35	17.25 - 20.25	27.60 - 32.40	32.20 - 37.80	55.20 - 64.80	
	REMOTE SENSING	Provided								
	REMOTE ON/OFF	Provided (Negative Logic L : ON, H :OFF)								
ISOLATION	INPUT-OUTPUT	AC3,000V 1minute, Cutoff current = 10mA, DC500V 50MΩ min (20±15°C)								
	INPUT-FG	AC2,000V 1minute, Cutoff current = 10mA, DC500V 50MΩ min (20±15°C)								
	OUTPUT-FG	AC500V 1minute, Cutoff current = 100mA, DC500V 50MΩ min (20±15°C)								
ENVIRONMENT	OPERATING TEMP., HUMID. AND ALTITUDE	-40 to +100°C (On aluminum base plate), 20 - 95%RH (Non condensing) (Refer to "Derating"), 3,000m (10,000 feet) max								
	STORAGE TEMP., HUMID. AND ALTITUDE	-40 to +100°C, 20 - 95%RH (Non condensing), 9,000m (30,000 feet) max								
	VIBRATION	10 - 55Hz, 49.0m/s ² (5G), 3minutes period, 60minutes each along X, Y and Z axis								
	IMPACT	196.1m/s ² (20G), 11ms, once each along X, Y and Z axis								
SAFETY	AGENCY APPROVALS	UL60950-1, C-UL, EN62368-1								
OTHERS	CASE SIZE/WEIGHT	58.4 × 12.7 × 61mm [2.3 × 0.5 × 2.4 inches](W × H × D) / 100g max								
	COOLING METHOD	Conduction cooling (e.g. heat radiation from the aluminum base plate to the attached heat sink)								

*1 At rated input(DC280V) and rated load.
 *2 Ripple and ripple noise is measured by using measuring board. Refer to the manual.
 *3 Drift is the change in DC output for an eight hour period after a half-hour warm-up at 25°C, with the input voltage held constant at the rated input/output.
 *4 Refer to the manual for input range.

External view

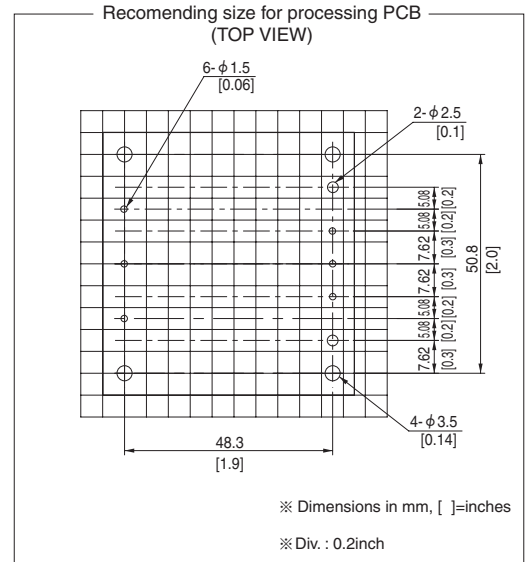
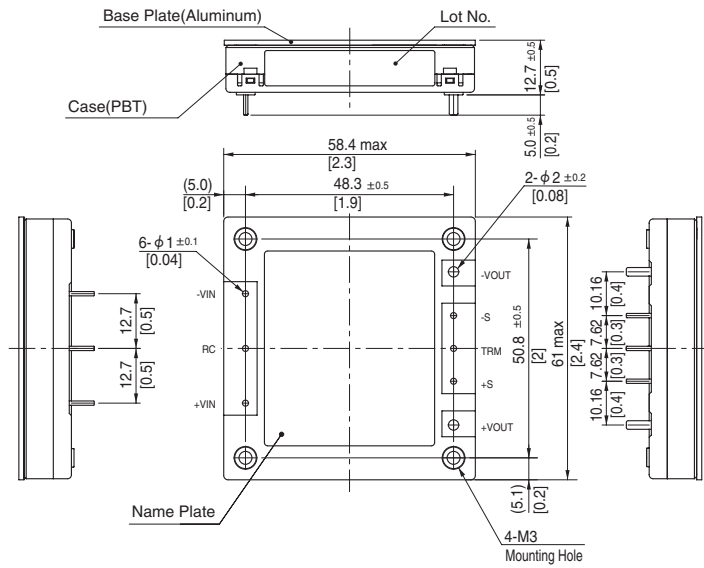

- ※ Tolerance : ± 0.3 [± 0.012]
- ※ Weight : 100g max
- ※ Dimensions in mm, []=inches
- ※ Mounting hole screwing torque : $0.49\text{N} \cdot \text{m}$ (5.0kgf · cm) max

Pin Configuration

DHS50/100

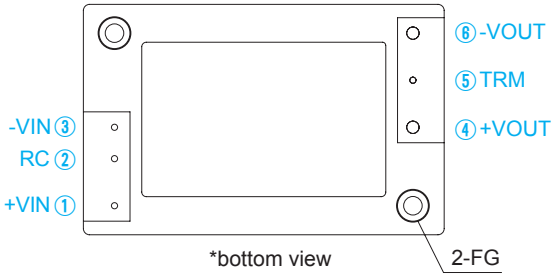

No.		Pin Connection	Function
DHS50/100	DHS200/250		
①	①	+VIN	+DC input
②	②	RC	Remote ON/OFF
③	③	-VIN	-DC input
④	④	+VOUT	+DC output
—	⑤	+S	+Remote sensing
⑤	⑥	TRM	Adjustment of output voltage
—	⑦	-S	-Remote sensing
⑥	⑧	-VOUT	-DC output
—	—	Mounting hole	Mounting hole

DHS200/250

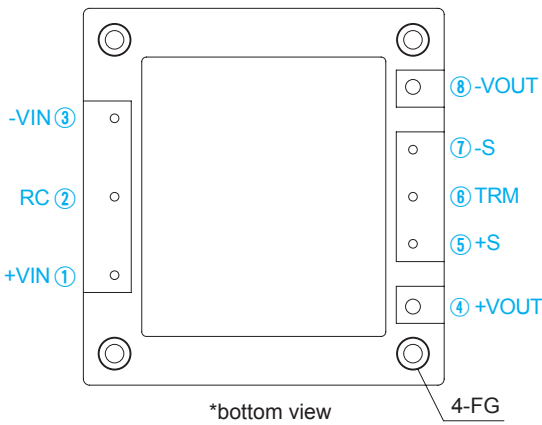

Implementation • Mounting Method

Mounting method

- The unit can be mounted in any direction. When two or more power supplies are used side by side, position them with proper intervals to allow enough air ventilation. Aluminum base plate temperature around each power supply should not exceed the temperature range shown in "Derating".
- Avoid placing the DC input line pattern lay out underneath the unit, it will increase the line conducted noise. Make sure to leave an ample distance between the line pattern lay out and the unit. Also avoid placing the DC output line pattern underneath the unit because it may increase the output noise. Lay out the pattern away from the unit.
- High-frequency noise radiates directly from the unit to the atmosphere. Therefore, design the shield pattern on the printed circuit board and connect its one to FG. The shield pattern prevents noise radiation.

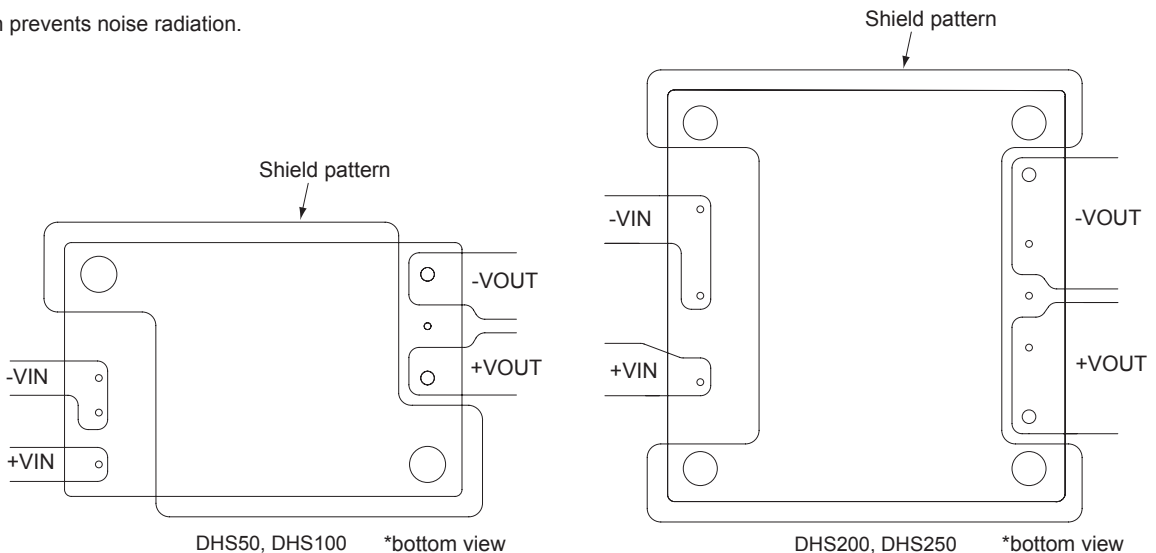

Implementation • Mounting Method

Stress onto the pins

- Applying excessive stress to the input or output pins of the power module may damage internal connections. Avoid applying stress in excess of that shown in right figure.
- Input and output pins are soldered onto the internal PCB. Do not bend or pull the leads with excessive force.
- As unexpected stress may be applied to the pins, set the diameter of the PCB mounting hole at 3.5mm.
- As unexpected stress may be applied to the pins from vibration or shock, fix the power module by using the mounting holes with screws to reduce stress.
- Fix the power module to the PCB with the screws before soldering the input and output pins to prevent the PCB pattern being damaged.

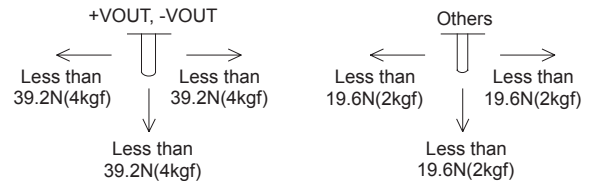
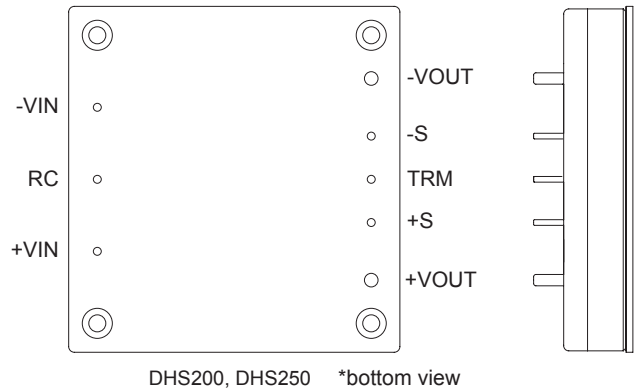
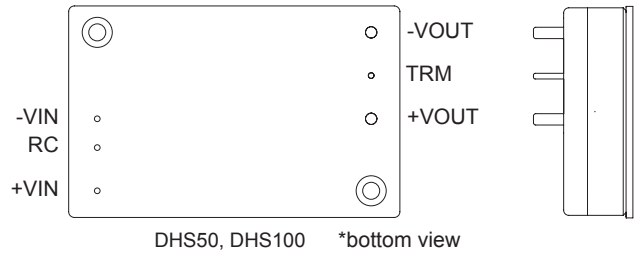

Soldering temperature

- Flow soldering : 260°C for up to 15 seconds.
- Soldering iron (26W) : 450°C for up to 5 seconds.

DHS

Derating

- Use the power modules with conduction cooling (e.g. heat dissipation from the aluminum base plate to the attached heat sink).Below shows the derating curves with respect to the aluminum base plate temperature. Note that operation within the hatched areas will cause a significant level of ripple and ripple noise.
- Please measure the temperature on the aluminum base plate edge side when you cannot measure the temperature of the center part of the aluminum base plate. In this case, please take 5deg temperature margin from the derating characteristic of below.
- It is necessary to note the thermal fatigue life by power cycle. Please reduce the temperature fluctuation range as much as possible when the up and down of the temperature are frequently generated. Contact us for more information on cooling methods.

● DHS50, DHS100

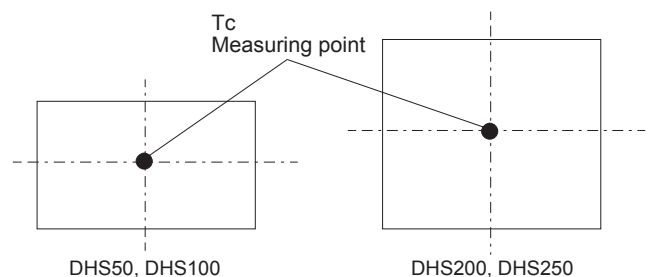
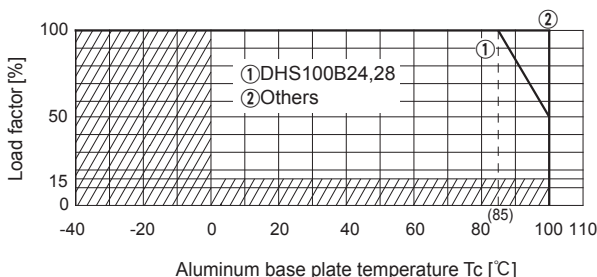

Derating

DHS200

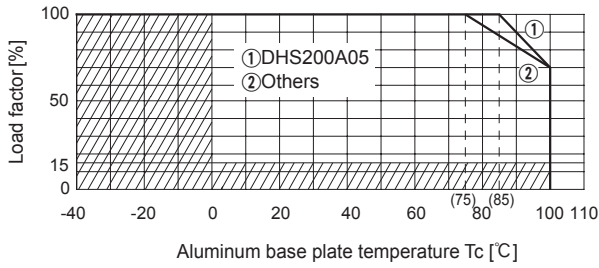

DHS250

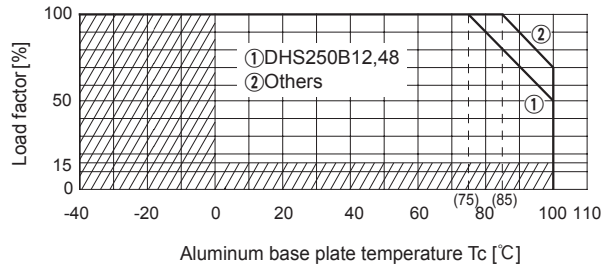

Instruction Manual

◆ It is necessary to read the "Instruction Manual" and "Before using our product" before you use our product.

Instruction Manual <https://www.cosel.co.jp/redirect/catalog/en/DHS/>
 Before using our product <https://en.cosel.co.jp/technical/caution/index.html>

DHS



NOTICE



Basic Characteristics Data

Model	Circuit method	Switching frequency [kHz]	Input current [A]	Rated input fuse	PCB/Pattern			Series/Parallel operation availability	
					Material	Single sided	Double sided	Series operation	Parallel operation
DHS50A DHS50B	Forward converter	470	*1	-	Aluminum	Yes		Yes	*2
DHS100A DHS100B	Forward converter	470	*1	-	Aluminum	Yes		Yes	*2
DHS200A DHS250B	Forward converter	360	*1	-	Aluminum	Yes		Yes	*2

*1 Refer to Specification.

*2 Refer to Instruction Manual.

DHS



Medical
electric
equipment



Power
Factor
Correction



World wide



Low Profile



Safety
Approvals



Inrush
current
limiting



Isolated



OCP



OVP



Remote
ON/OFF



Parallel
Operation

TUNS-series

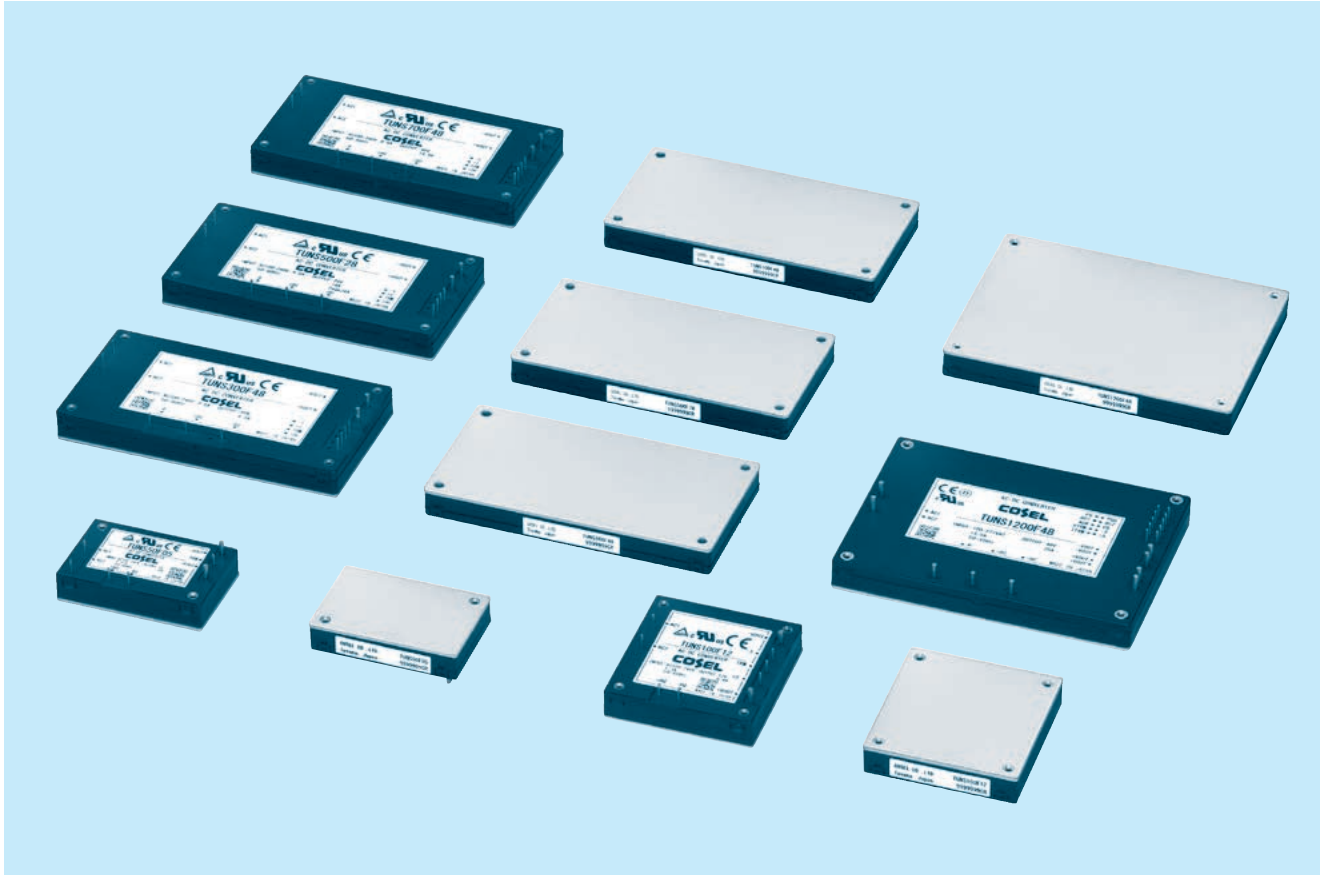

TUNS

Feature

AC-DC Power Module Type Converter
 Harmonic attenuator (Complies with IEC61000-3-2 class A)
 Thin and small size
 Built-in overcurrent, overvoltage and thermal protection circuits
 Mounting hole (M3 tapped)

<TUNS50F/100F/300F/500F/700F>
 Universal input 85 - 264VAC
 Peak current (TUNS500F)

<TUNS1200F>
 Wide input 85 - 305VAC
 For medical electric equipment
 Constant current regulation
 Output voltage can be varied to near 0V
 Parallel operation possible

CE marking

Low voltage directive
 RoHS Directive

UKCA marking

Electrical Equipment Safety Regulations
 RoHS Regulations

Safety Approval

UL60950-1, C-UL, EN62368-1
 (TUNS50F/100F/300F/500F/700F)
 UL62368-1, C-UL, EN62368-1 (TUNS1200F)
 ANSI/AAMI ES60601-1, EN60601-1 3rd (TUNS1200F)

5-year warranty

Optional parts

Heat sink

TUNS50F

TUN S 50 F 05 -□

① ② ③ ④ ⑤ ⑥



*Providing heat sink as option

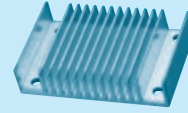

- ① Series name
- ② Single output
- ③ Output wattage
- ④ Universal Input
- ⑤ Output voltage
- ⑥ Optional
- T : with Mounting hole (φ 3.4 thru)

*Avoid short circuit between +BC and -BC. It may cause the failure of inside components.
 *Keep TRM open, if output voltage adjustment is not necessary.

MODEL	TUNS50F05	TUNS50F12	TUNS50F24
MAX OUTPUT WATTAGE[W]	50.0	50.4	50.4
DC OUTPUT	5V 10A	12V 4.2A	24V 2.1A

SPECIFICATIONS

	MODEL	TUNS50F05	TUNS50F12	TUNS50F24	
INPUT	VOLTAGE[V]	AC85 - 264 1 φ (Refer to "Derating")			
	CURRENT[A]	ACIN 100V	0.67typ (Io=100%)		
		ACIN 200V	0.35typ (Io=100%)		
	FREQUENCY[Hz]	50/60 (47 - 63)			
	EFFICIENCY[%]	ACIN 100V	79typ	83typ	84typ
		ACIN 200V	81typ	84typ	86typ
	POWER FACTOR (Io=100%)	ACIN 100V	0.95typ		
		ACIN 200V	0.90typ		
INRUSH CURRENT	Limited by external components (Thermistor)				
LEAKAGE CURRENT[mA]	0.75max (ACIN 240V 60Hz, Io=100%, According to IEC62368-1)				
OUTPUT	VOLTAGE[V]	5	12	24	
	CURRENT[A]	10	4.2	2.1	
	LINE REGULATION[mV]	10max	24max	48max	
	LOAD REGULATION[mV]	10max	24max	48max	
	RIPPLE[mVp-p]	0 to +100°C *1	80max	120max	120max
		-40 to 0°C *1	120max	150max	150max
		0 to 15% Load *1	200max	280max	380max
	RIPPLE NOISE[mVp-p]	0 to +100°C *1	120max	150max	150max
		-40 to 0°C *1	200max	200max	250max
		0 to 15% Load *1	280max	360max	460max
	TEMPERATURE REGULATION[mV]	0 to +65°C	50max	120max	240max
		-40 to +100°C	100max	240max	480max
	DRIFT[mV]	*2	20max	40max	90max
OUTPUT VOLTAGE ADJUSTMENT RANGE[V]	Fixed (TRM pin open), adjustable by external resistor or external signal				
	4.50 - 6.00	10.80 - 13.20	21.60 - 26.40		
OUTPUT VOLTAGE SETTING[V]	4.97 - 5.13	11.91 - 12.29	23.62 - 24.38		
PROTECTION CIRCUIT AND OTHERS	OVERCURRENT PROTECTION	Works over 105% of rating and recovers automatically			
	OVERVOLTAGE PROTECTION[V]	6.30 - 7.00	13.90 - 16.35	27.60 - 32.40	
	REMOTE SENSING	Not provided			
	REMOTE ON/OFF	Not provided			
ISOLATION	INPUT-OUTPUT	AC3,000V 1minute, Cutoff current = 10mA, DC500V 50MΩ min (20±15°C)			
	INPUT-FG	AC2,000V 1minute, Cutoff current = 10mA, DC500V 50MΩ min (20±15°C)			
	OUTPUT-FG	AC500V 1minute, Cutoff current = 100mA, DC500V 50MΩ min (20±15°C)			
ENVIRONMENT	OPERATING TEMP., HUMID. AND ALTITUDE	-40 to +100°C (On aluminum base plate), 20 - 95%RH (Non condensing) (Refer to "Derating"), 3,000m (10,000 feet) max			
	STORAGE TEMP., HUMID. AND ALTITUDE	-40 to +100°C, 20 - 95%RH (Non condensing), 9,000m (30,000 feet) max			
	VIBRATION	10 - 55Hz, 49.0m/s ² (5G), 3minutes period, 60minutes each along X, Y and Z axis			
	IMPACT	196.1m/s ² (20G), 11ms, once each along X, Y and Z axis			
SAFETY AND NOISE REGULATIONS	AGENCY APPROVALS	UL60950-1, C-UL (CSA60950-1), EN62368-1			
	HARMONIC ATTENUATOR	Complies with IEC61000-3-2 (Class A) *3			
OTHERS	CASE SIZE/WEIGHT	58.4 X 12.7 X 37.3mm [2.3 X 0.5 X 1.47 inches] (W X H X D) / 80g max			
	COOLING METHOD	Conduction cooling (e.g. heat radiation from the aluminum base plate to the attached heat sink)			

*1 Refer to instruction manual for measuring method of electric characteristics.
 *2 Drift is the change in DC output for an eight hour period after a half-hour warm-up at 25°C, with the input voltage held constant at the rated input/output.
 *3 Please contact us about another class.

External view

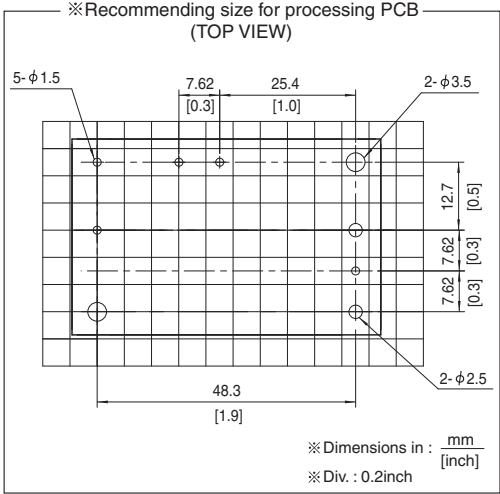
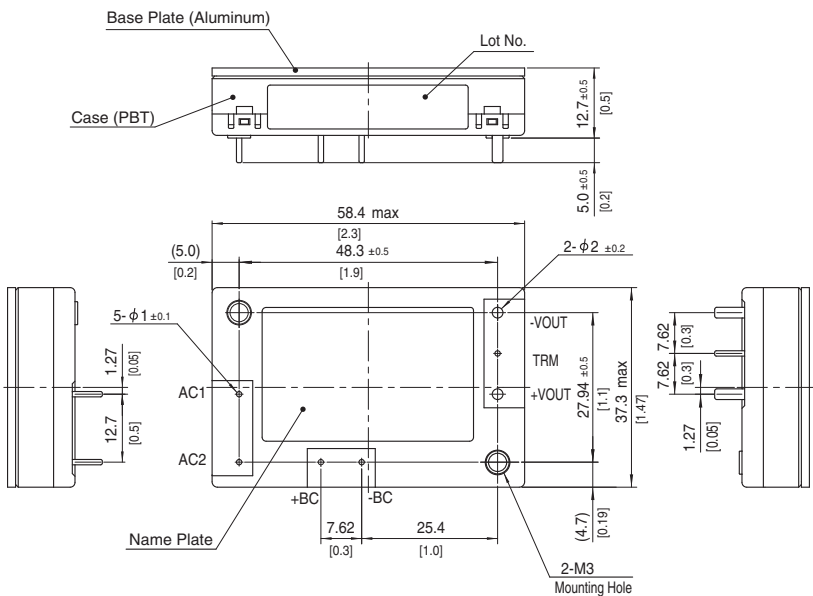

- ※ Tolerance : ± 0.3 [± 0.012]
- ※ Weight : 80g max
- ※ Dimensions in mm, []=inches
- ※ Mounting hole screwing torque : 0.49N · m (5.0kgf · cm) max

TUNS100F

TUN S 100 F 05 -□

① ② ③ ④ ⑤ ⑥

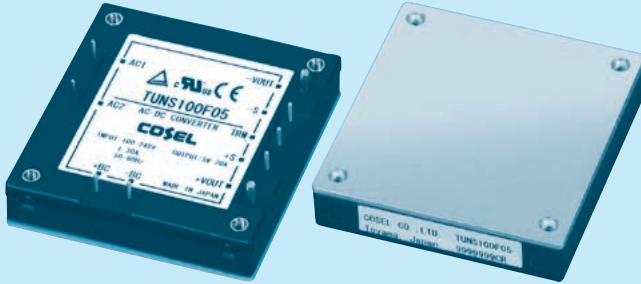

*Providing heat sink as option

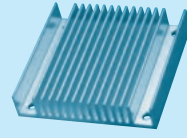

- ① Series name
- ② Single output
- ③ Output wattage
- ④ Universal Input
- ⑤ Output voltage
- ⑥ Optional
- T : with Mounting hole (φ 3.4 thru)

*Avoid short circuit between +BC and -BC. It may cause the failure of inside components.
 *Keep TRM open, if output voltage adjustment is not necessary.
 *If remote sensing is not necessary, connect between +Vout & +S and between -Vout & -S.

MODEL	TUNS100F05	TUNS100F12	TUNS100F24
MAX OUTPUT WATTAGE[W]	100.0	100.8	100.8
DC OUTPUT	5V 20A	12V 8.4A	24V 4.2A

SPECIFICATIONS

	MODEL	TUNS100F05	TUNS100F12	TUNS100F24	
INPUT	VOLTAGE[V]	AC85 - 264 1 φ (Refer to "Derating")			
	CURRENT[A]	ACIN 100V	1.3typ (Io=100%)		
		ACIN 200V	0.7typ (Io=100%)		
	FREQUENCY[Hz]	50/60 (47 - 63)			
	EFFICIENCY[%]	ACIN 100V	82typ	83typ	84typ
		ACIN 200V	85typ	85typ	86typ
	POWER FACTOR (Io=100%)	ACIN 100V	0.95typ		
		ACIN 200V	0.90typ		
INRUSH CURRENT	Limited by external components (Thermistor)				
LEAKAGE CURRENT[mA]	0.75max (ACIN 240V 60Hz, Io=100%, According to IEC62368-1)				
OUTPUT	VOLTAGE[V]	5	12	24	
	CURRENT[A]	20	8.4	4.2	
	LINE REGULATION[mV]	10max	24max	48max	
	LOAD REGULATION[mV]	10max	24max	48max	
	RIPPLE[mVp-p]	0 to +100°C *1	80max	120max	120max
		-40 to 0°C *1	120max	150max	150max
		0 to 15% Load *1	160max	240max	240max
	RIPPLE NOISE[mVp-p]	0 to +100°C *1	120max	150max	150max
		-40 to 0°C *1	200max	200max	250max
		0 to 15% Load *1	240max	300max	300max
	TEMPERATURE REGULATION[mV]	0 to +65°C	50max	120max	240max
-40 to +100°C		100max	240max	480max	
DRIFT[mV]	*2	20max	40max	90max	
OUTPUT VOLTAGE ADJUSTMENT RANGE[V]	Fixed (TRM pin open), adjustable by external resistor or external signal				
OUTPUT VOLTAGE SETTING[V]	4.50 - 6.00	10.80 - 13.20	21.60 - 26.40		
OUTPUT VOLTAGE SETTING[V]	4.97 - 5.13	11.91 - 12.29	23.62 - 24.38		
PROTECTION CIRCUIT AND OTHERS	OVERCURRENT PROTECTION	Works over 105% of rating and recovers automatically			
	OVERVOLTAGE PROTECTION[V]	6.30 - 7.00	13.90 - 16.35	27.60 - 32.40	
	REMOTE SENSING	Provided			
	REMOTE ON/OFF	Not provided			
ISOLATION	INPUT-OUTPUT	AC3,000V 1minute, Cutoff current = 10mA, DC500V 50MΩ min (20±15°C)			
	INPUT-FG	AC2,000V 1minute, Cutoff current = 10mA, DC500V 50MΩ min (20±15°C)			
	OUTPUT-FG	AC500V 1minute, Cutoff current = 100mA, DC500V 50MΩ min (20±15°C)			
ENVIRONMENT	OPERATING TEMP., HUMID. AND ALTITUDE	-40 to +100°C (On aluminum base plate), 20 - 95%RH (Non condensing) (Refer to "Derating"), 3,000m (10,000 feet) max			
	STORAGE TEMP., HUMID. AND ALTITUDE	-40 to +100°C, 20 - 95%RH (Non condensing), 9,000m (30,000 feet) max			
	VIBRATION	10 - 55Hz, 49.0m/s ² (5G), 3minutes period, 60minutes each along X, Y and Z axis			
SAFETY AND NOISE REGULATIONS	IMPACT	196.1m/s ² (20G), 11ms, once each along X, Y and Z axis			
	AGENCY APPROVALS	UL60950-1, C-UL (CSA60950-1), EN62368-1			
OTHERS	HARMONIC ATTENUATOR	Complies with IEC61000-3-2 (Class A) *3			
	CASE SIZE/WEIGHT	58.4 X 12.7 X 61.0mm [2.3 X 0.5 X 2.4 inches] (W X H X D) / 120g max			
	COOLING METHOD	Conduction cooling (e.g. heat radiation from the aluminum base plate to the attached heat sink)			

*1 Refer to instruction manual for measuring method of electric characteristics.
 *2 Drift is the change in DC output for an eight hour period after a half-hour warm-up at 25°C, with the input voltage held constant at the rated input/output.
 *3 Please contact us about another class.

External view

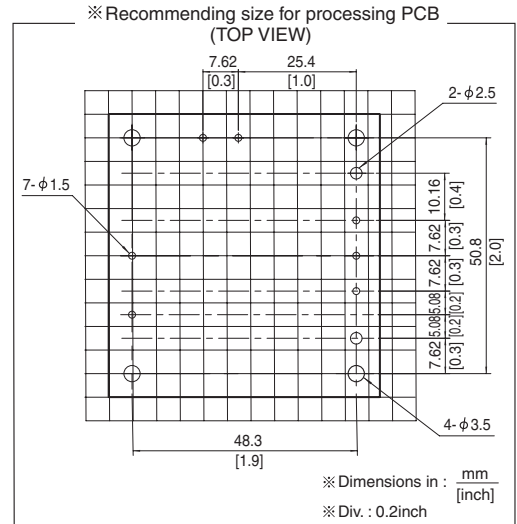
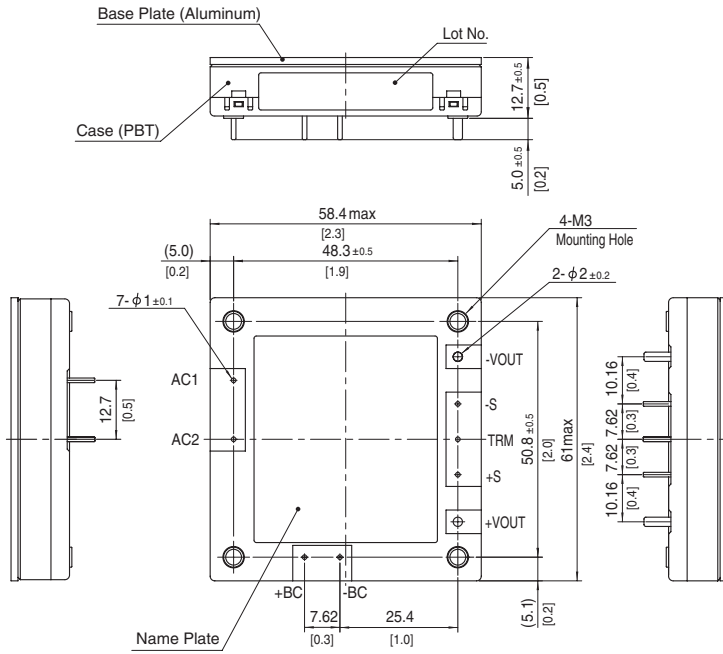

- ※ Tolerance : ± 0.3 [± 0.012]
- ※ Weight : 120g max
- ※ Dimensions in mm, []=inches
- ※ Mounting hole screwing torque : 0.49N · m (5.0kgf · cm) max

TUNS300F

TUN S 300 F 48 -□

① ② ③ ④ ⑤ ⑥

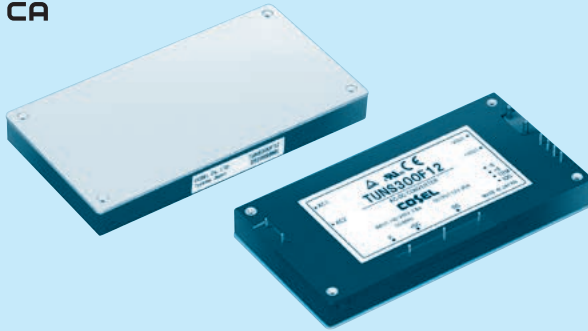
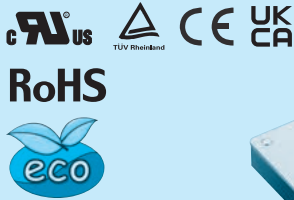

- ① Series name
- ② Single output
- ③ Output wattage
- ④ Universal Input
- ⑤ Output voltage
- ⑥ Optional
 - T : with Mounting hole (φ 3.4 thru)
 - Y1: Output voltage adjustment range ±20% (Only 48V)
 - R1: with Remote ON/OFF (Negative logic control)
 - R2: with Remote ON/OFF (Negative logic and Low standby power)
 - R3: with Remote ON/OFF (Positive logic control)
 - N1: Auto restart from thermal protection

* Avoid short circuit between +BC/R and -BC. It may cause the failure of inside components.
 * Keep TRM open, if output voltage adjustment is not necessary.
 * If remote sensing is not necessary, connect between +Vout & +S and between -Vout & -S.

MODEL	TUNS300F12	TUNS300F28	TUNS300F48
MAX OUTPUT WATTAGE[W]	300	308	312
DC OUTPUT	12V 25A	28V 11A	48V 6.5A

SPECIFICATIONS

	MODEL	TUNS300F12	TUNS300F28	TUNS300F48	
INPUT	VOLTAGE[V]	AC85 - 264 1 φ			
	CURRENT[A]	ACIN 100V	3.6typ (Io=100%)		
		ACIN 200V	1.8typ (Io=100%)		
	FREQUENCY[Hz]	50/60 (47 - 63)			
	EFFICIENCY[%]	ACIN 100V	84typ	87typ	87typ
		ACIN 200V	86typ	89typ	90typ
	POWER FACTOR (Io=100%)	ACIN 100V	0.96typ		
		ACIN 200V	0.93typ		
INRUSH CURRENT	Limited by external resistance				
LEAKAGE CURRENT[ma]	0.75max (ACIN 240V 60Hz, Io=100%, According to IEC62368-1)				
OUTPUT	VOLTAGE[V]	12	28	48	
	CURRENT[A]	25	11	6.5	
	LINE REGULATION[mV]	24max	56max	96max	
	LOAD REGULATION[mV]	24max	56max	96max	
	RIPPLE[mVp-p]	0 to +100°C*1	120max	180max	250max
		-40 to 0°C*1	150max	200max	300max
	RIPPLE NOISE[mVp-p]	0 to +100°C*1	150max	200max	300max
		-40 to 0°C*1	200max	300max	450max
	TEMPERATURE REGULATION[mV]	0 to +65°C	120max	280max	480max
		-40 to +100°C	240max	560max	960max
	DRIFT[mV]	*2	40max	90max	180max
OUTPUT VOLTAGE ADJUSTMENT RANGE[V]	Fixed (TRM pin open), adjustable by external resistor or external signal 9.60 - 14.40				
OUTPUT VOLTAGE SETTING[V]	11.91 - 12.29	22.40 - 33.60	38.40 - 52.80 (-Y1 Option : 38.4 - 57.6)		
PROTECTION CIRCUIT AND OTHERS	OVERCURRENT PROTECTION	Works over 105% of rating and recovers automatically			
	OVERVOLTAGE PROTECTION[V]	15.00 - 16.80	35.00 - 39.20	55.20 - 64.80 (-Y1 Option : 60.0 - 67.2)	
	REMOTE SENSING	Provided			
REMOTE ON/OFF	Optional (External power supply is required)				
ISOLATION	INPUT-OUTPUT · RC	*4	AC3,000V 1minute, Cutoff current = 10mA, DC500V 50MΩ min (20±15°C)		
	INPUT-FG		AC2,000V 1minute, Cutoff current = 10mA, DC500V 50MΩ min (20±15°C)		
	OUTPUT · RC-FG	*4	AC500V 1minute, Cutoff current = 100mA, DC500V 50MΩ min (20±15°C)		
	OUTPUT-RC	*4	AC100V 1minute, Cutoff current = 100mA, DC100V 10MΩ min (20±15°C)		
ENVIRONMENT	OPERATING TEMP., HUMID. AND ALTITUDE	-40 to +100°C (On aluminum base plate), 20 - 95%RH (Non condensing) (Refer to "Derating"), 3,000m (10,000 feet) max			
	STORAGE TEMP., HUMID. AND ALTITUDE	-40 to +100°C, 20 - 95%RH (Non condensing), 9,000m (30,000 feet) max			
	VIBRATION	10 - 55Hz, 49.0m/s ² (5G), 3minutes period, 60minutes each along X, Y and Z axis			
	IMPACT	196.1m/s ² (20G), 11ms, once each along X, Y and Z axis			
SAFETY AND NOISE REGULATIONS	AGENCY APPROVALS	UL60950-1, C-UL (CSA60950-1), EN62368-1			
	HARMONIC ATTENUATOR	Complies with IEC61000-3-2 (Class A) *3			
OTHERS	CASE SIZE/WEIGHT	117.3 × 12.7 × 61.5mm [4.62 × 0.5 × 2.42 inches] (W × H × D) / 190g max			
	COOLING METHOD	Conduction cooling (e.g. heat radiation from the aluminum base plate to the attached heat sink)			

*1 Refer to instruction manual for measuring method of electric characteristics.
 *2 Drift is the change in DC output for an eight hour period after a half-hour warm-up at 25°C, with the input voltage held constant at the rated input/output.
 *3 Please contact us about another class.
 *4 "RC" is applicable when remote control (optional) is added.

External view

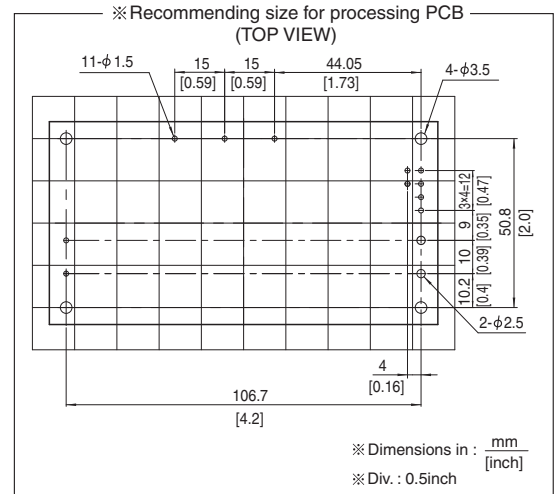
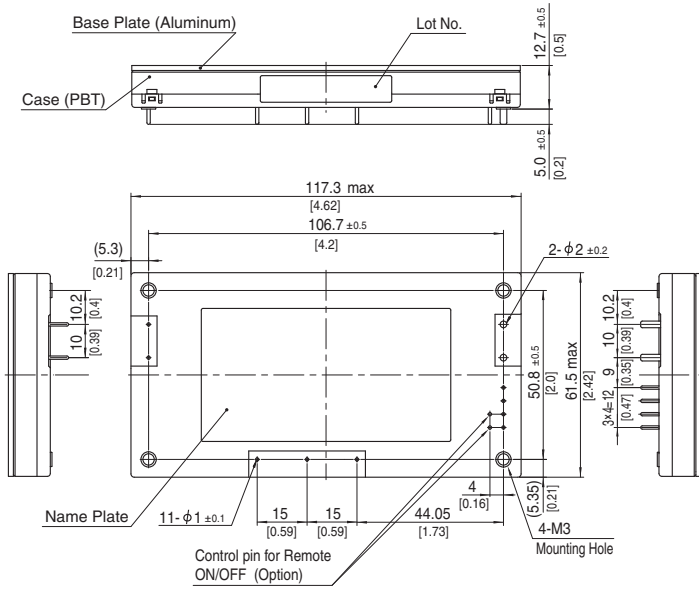

- ※ Tolerance : ± 0.3 [± 0.012]
- ※ Weight : 190g max
- ※ Dimensions in mm, []=inches
- ※ Mounting hole screwing torque : $0.49\text{N} \cdot \text{m}$ (5.0kgf · cm) max

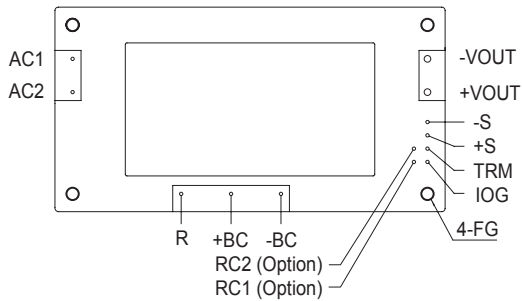

TUNS500F

TUN S 500 F 48 -□

① ② ③ ④ ⑤ ⑥

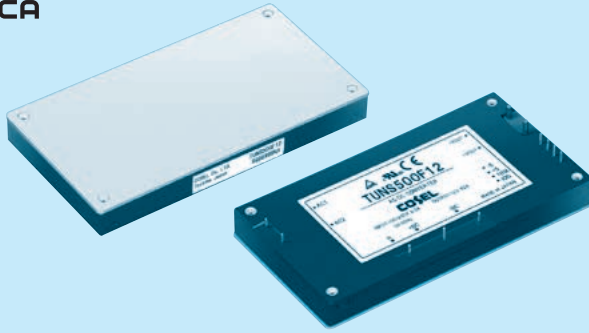
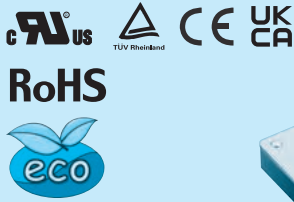

- ① Series name
- ② Single output
- ③ Output wattage
- ④ Universal Input
- ⑤ Output voltage
- ⑥ Optional
 - T : with Mounting hole (φ 3.4 thru)
 - Y1: Output voltage adjustment range ±20% (Only 48V)
 - R1: with Remote ON/OFF (Negative logic control)
 - R2: with Remote ON/OFF (Negative logic and Low standby power)
 - R3: with Remote ON/OFF (Positive logic control)
 - N1: Auto restart from thermal protection

* Avoid short circuit between +BC/R and -BC. It may cause the failure of inside components.
 * Keep TRM open, if output voltage adjustment is not necessary.
 * If remote sensing is not necessary, connect between +Vout & +S and between -Vout & -S.

MODEL	TUNS500F12	TUNS500F28	TUNS500F48
MAX OUTPUT WATTAGE[W]	504	504	504
DC OUTPUT	12V 42A (Peak 55A)	28V 18A (Peak 24A)	48V 10.5A (Peak 14A)

SPECIFICATIONS

	MODEL	TUNS500F12	TUNS500F28	TUNS500F48	
INPUT	VOLTAGE[V]	AC85 - 264 1 φ			
	CURRENT[A]	ACIN 100V	6.0typ (Io=100%)		
		ACIN 200V	3.0typ (Io=100%)		
	FREQUENCY[Hz]	50/60 (47 - 63)			
	EFFICIENCY[%]	ACIN 100V	84typ	87typ	88typ
		ACIN 200V	86typ	90typ	90.5typ
	POWER FACTOR (Io=100%)	ACIN 100V	0.96typ		
		ACIN 200V	0.93typ		
INRUSH CURRENT	Limited by external resistance				
LEAKAGE CURRENT[ma]	0.75max (ACIN 240V 60Hz, Io=100%, According to IEC62368-1)				
OUTPUT	VOLTAGE[V]	12	28	48	
	CURRENT[A]	*3 42 (Peak 55)	18 (Peak 24)	10.5 (Peak 14)	
	LINE REGULATION[mV]	24max	56max	96max	
	LOAD REGULATION[mV]	24max	56max	96max	
	RIPPLE[mVp-p]	0 to +100°C *1	120max	180max	250max
		-40 to 0°C *1	150max	200max	300max
	RIPPLE NOISE[mVp-p]	0 to +100°C *1	150max	200max	300max
		-40 to 0°C *1	200max	300max	450max
	TEMPERATURE REGULATION[mV]	0 to +65°C	120max	280max	480max
		-40 to +100°C	240max	560max	960max
	DRIFT[mV]	*2 40max	90max	180max	
OUTPUT VOLTAGE ADJUSTMENT RANGE[V]	Fixed (TRM pin open), adjustable by external resistor or external signal 9.60 - 14.40				
OUTPUT VOLTAGE SETTING[V]	11.91 - 12.29	27.56 - 28.44	38.40 - 52.80 (-Y1 Option : 38.4 - 57.6)		
PROTECTION CIRCUIT AND OTHERS	OVERCURRENT PROTECTION	Works over 101% of peak current and recovers automatically			
	OVERVOLTAGE PROTECTION[V]	15.00 - 16.80	35.00 - 39.20	55.20 - 64.80 (-Y1 Option : 60.0 - 67.2)	
	REMOTE SENSING	Provided			
REMOTE ON/OFF	Optional (External power supply is required)				
ISOLATION	INPUT-OUTPUT · RC	*5 AC3,000V 1minute, Cutoff current = 10mA, DC500V 50MΩ min (20±15°C)			
	INPUT-FG	AC2,000V 1minute, Cutoff current = 10mA, DC500V 50MΩ min (20±15°C)			
	OUTPUT · RC-FG	*5 AC500V 1minute, Cutoff current = 100mA, DC500V 50MΩ min (20±15°C)			
	OUTPUT-RC	*5 AC100V 1minute, Cutoff current = 100mA, DC100V 10MΩ min (20±15°C)			
ENVIRONMENT	OPERATING TEMP., HUMID. AND ALTITUDE	-40 to +100°C (On aluminum base plate), 20 - 95%RH (Non condensing) (Refer to "Derating"), 3,000m (10,000 feet) max			
	STORAGE TEMP., HUMID. AND ALTITUDE	-40 to +100°C, 20 - 95%RH (Non condensing), 9,000m (30,000 feet) max			
	VIBRATION	10 - 55Hz, 49.0m/s ² (5G), 3minutes period, 60minutes each along X, Y and Z axis			
	IMPACT	196.1m/s ² (20G), 11ms, once each along X, Y and Z axis			
SAFETY AND NOISE REGULATIONS	AGENCY APPROVALS	UL60950-1, C-UL (CSA60950-1), EN62368-1			
	HARMONIC ATTENUATOR	Complies with IEC61000-3-2 (Class A) *4			
OTHERS	CASE SIZE/WEIGHT	117.3 × 12.7 × 61.5mm [4.62 × 0.5 × 2.42 inches] (W × H × D) / 190g max			
	COOLING METHOD	Conduction cooling (e.g. heat radiation from the aluminum base plate to the attached heat sink)			

*1 Refer to instruction manual for measuring method of electric characteristics.
 *2 Drift is the change in DC output for an eight hour period after a half-hour warm-up at 25°C, with the input voltage held constant at the rated input/output.
 *3 () means peak current. Avoid operating with peak current continuously. It may cause failure of the components inside the product. There are limitation of available condition of the peak current, such as peak time, duty etc. (Refer to the instruction manual in detail).
 *4 Please contact us about another class.
 *5 "RC" is applicable when remote control (optional) is added.

External view

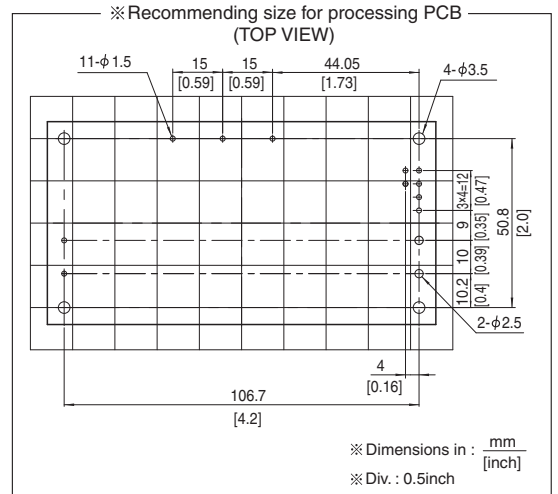
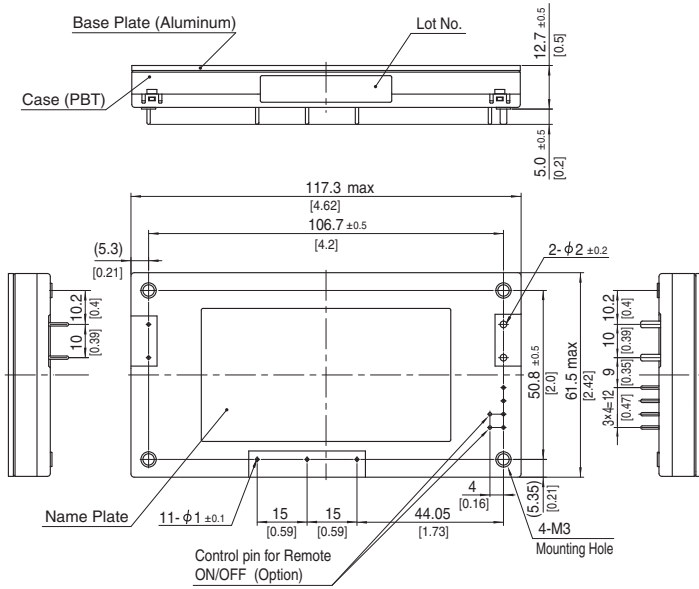

- ※ Tolerance : ± 0.3 [± 0.012]
- ※ Weight : 190g max
- ※ Dimensions in mm, []=inches
- ※ Mounting hole screwing torque : $0.49\text{N} \cdot \text{m}$ (5.0kgf · cm) max

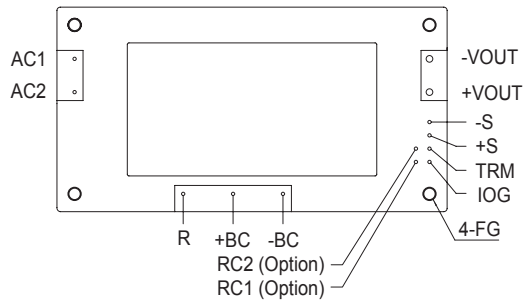

TUNS700F

TUN S 700 F 48 -□
 ① ② ③ ④ ⑤ ⑥

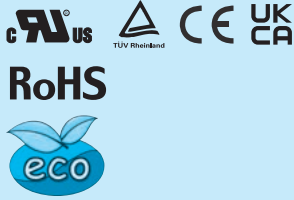

- ① Series name
- ② Single output
- ③ Output wattage
- ④ Universal Input
- ⑤ Output voltage
- ⑥ Optional
- T : with Mounting hole (φ 3.4 thru)
- Y1: Output voltage adjustment range ±20% (Only 48V)
- R1: with Remote ON/OFF (Negative logic control)
- R2: with Remote ON/OFF (Negative logic and Low standby power)
- R3: with Remote ON/OFF (Positive logic control)
- P : Parallel operation (Output voltage trimming disabled, Remote sensing disabled)

* Avoid short circuit between +BC/R and -BC. It may cause the failure of inside components.
 * Keep TRM open, if output voltage adjustment is not necessary.
 * If remote sensing is not necessary, connect between +Vout & +S and between -Vout & -S.

MODEL	TUNS700F12	TUNS700F28	TUNS700F48
MAX OUTPUT WATTAGE[W]	700.8	700.0	700.8
DC OUTPUT	12V 58.4A	28V 25A	48V 14.6A

SPECIFICATIONS

	MODEL	TUNS700F12	TUNS700F28	TUNS700F48	
INPUT	VOLTAGE[V]	AC85 - 264 1 φ			
	CURRENT[A]	ACIN 100V	8.6typ (Io=100%)		
		ACIN 200V	4.1typ (Io=100%)		
	FREQUENCY[Hz]	50/60 (47 - 63)			
	EFFICIENCY[%]	ACIN 100V	83typ	86typ	87typ
		ACIN 200V	86typ	89typ	90typ
	POWER FACTOR (Io=100%)	ACIN 100V	0.96typ		
		ACIN 200V	0.93typ		
INRUSH CURRENT	Limited by external resistance				
LEAKAGE CURRENT[ma]	0.75max (ACIN 240V 60Hz, Io=100%, According to IEC62368-1)				
OUTPUT	VOLTAGE[V]	12	28	48	
	CURRENT[A]	58.4	25	14.6	
	LINE REGULATION[mV]	24max	56max	96max	
	LOAD REGULATION[mV]	24max	56max	96max	
	RIPPLE[mVp-p]	0 to +100°C *1	120max	180max	250max
		-40 to 0°C *1	150max	200max	300max
	RIPPLE NOISE[mVp-p]	0 to +100°C *1	150max	200max	300max
		-40 to 0°C *1	200max	300max	450max
	TEMPERATURE REGULATION[mV]	0 to +65°C	120max	280max	480max
		-40 to +100°C	240max	560max	960max
	DRIFT[mV]	*2 40max	90max	180max	
	OUTPUT VOLTAGE ADJUSTMENT RANGE[V]	Fixed (TRM pin open), adjustable by external resistor or external signal			
OUTPUT VOLTAGE SETTING[V]	9.60 - 14.40	22.40 - 33.60	38.40 - 52.80 (-Y1 Option : 38.4 - 57.6)		
	11.91 - 12.29	27.56 - 28.44	47.24 - 48.76		
PROTECTION CIRCUIT AND OTHERS	OVERCURRENT PROTECTION	Works over 105% of rating and recovers automatically			
	OVERVOLTAGE PROTECTION[V]	15.00 - 16.80	35.00 - 39.20	55.20 - 64.80 (-Y1 Option : 60.0 - 67.2)	
	REMOTE SENSING	Provided			
	REMOTE ON/OFF	Optional (External power supply is required)			

MODEL	TUNS700F12-P	TUNS700F28-P	TUNS700F48-P
MAX OUTPUT WATTAGE[W]	700.8	700.0	700.8
DC OUTPUT	12V 58.4A	28V 25A	48V 14.6A

SPECIFICATIONS

	MODEL	TUNS700F12-P	TUNS700F28-P	TUNS700F48-P	
INPUT	VOLTAGE[V]	AC85 - 264 1 φ			
	CURRENT[A]	ACIN 100V	8.6typ (Io=100%)		
		ACIN 200V	4.1typ (Io=100%)		
	FREQUENCY[Hz]	50/60 (47 - 63)			
	EFFICIENCY[%]	ACIN 100V	83typ	86typ	87typ
		ACIN 200V	86typ	89typ	90typ
	POWER FACTOR (Io=100%)	ACIN 100V	0.96typ		
		ACIN 200V	0.93typ		
INRUSH CURRENT	Limited by external resistance				
LEAKAGE CURRENT[ma]	0.75max (ACIN 240V 60Hz, Io=100%, According to IEC62368-1)				
OUTPUT	VOLTAGE[V]	12	28	48	
	CURRENT[A]	58.4	25	14.6	
	VOLTAGE ACCURACY[%]	+5, -3	+5, -3	+5, -3	
	RIPPLE[mVp-p]	0 to +100°C *1	240max	360max	600max
		-40 to 0°C *1	300max	400max	700max
	RIPPLE NOISE[mVp-p]	0 to +30% Load *1	360max	540max	900max
		0 to +100°C *1	300max	400max	700max
	RIPPLE NOISE[mVp-p]	-40 to 0°C *1	400max	600max	1000max
		0 to +30% Load *1	450max	600max	1000max
	PROTECTION CIRCUIT AND OTHERS	OVERCURRENT PROTECTION	Works over 105% of rating and recovers automatically		
		OVERVOLTAGE PROTECTION[V]	15.00 - 16.80	35.00 - 39.20	55.20 - 64.80
		REMOTE ON/OFF	Optional (External power supply is required)		

GENERAL SPECIFICATIONS

ISOLATION	INPUT-OUTPUT · RC	*4 AC3,000V 1minute, Cutoff current = 10mA, DC500V 50MΩ min (20±15°C)
	INPUT-FG	AC2,000V 1minute, Cutoff current = 10mA, DC500V 50MΩ min (20±15°C)
	OUTPUT · RC-FG	*4 AC500V 1minute, Cutoff current = 100mA, DC500V 50MΩ min (20±15°C)
	OUTPUT-RC	*4 AC100V 1minute, Cutoff current = 100mA, DC100V 10MΩ min (20±15°C)
ENVIRONMENT	OPERATING TEMP., HUMID. AND ALTITUDE	-40 to +100°C (On aluminum base plate), 20 - 95%RH (Non condensing) (Refer to "Derating"), 3,000m (10,000 feet) max
	STORAGE TEMP., HUMID. AND ALTITUDE	-40 to +100°C, 20 - 95%RH (Non condensing), 9,000m (30,000 feet) max
	VIBRATION	10 - 55Hz, 49.0m/s ² (5G), 3minutes period, 60minutes each along X, Y and Z axis
	IMPACT	196.1m/s ² (20G), 11ms, once each along X, Y and Z axis
SAFETY AND NOISE REGULATIONS	AGENCY APPROVALS	UL60950-1, C-UL (CSA60950-1), EN62368-1
	HARMONIC ATTENUATOR	Complies with IEC61000-3-2 (Class A) *3
OTHERS	CASE SIZE/WEIGHT	117.3×12.7×61.5mm [4.62×0.5×2.42 inches] (W×H×D) / 190g max
	COOLING METHOD	Conduction cooling (e.g. heat radiation from the aluminum base plate to the attached heat sink)

- *1 Refer to instruction manual for measuring method of electric characteristics.
- *2 Drift is the change in DC output for an eight hour period after a half-hour warm-up at 25°C, with the input voltage held constant at the rated input/output.
- *3 Please contact us about another class.
- *4 "RC" is applicable when remote control (optional) is added.

External view

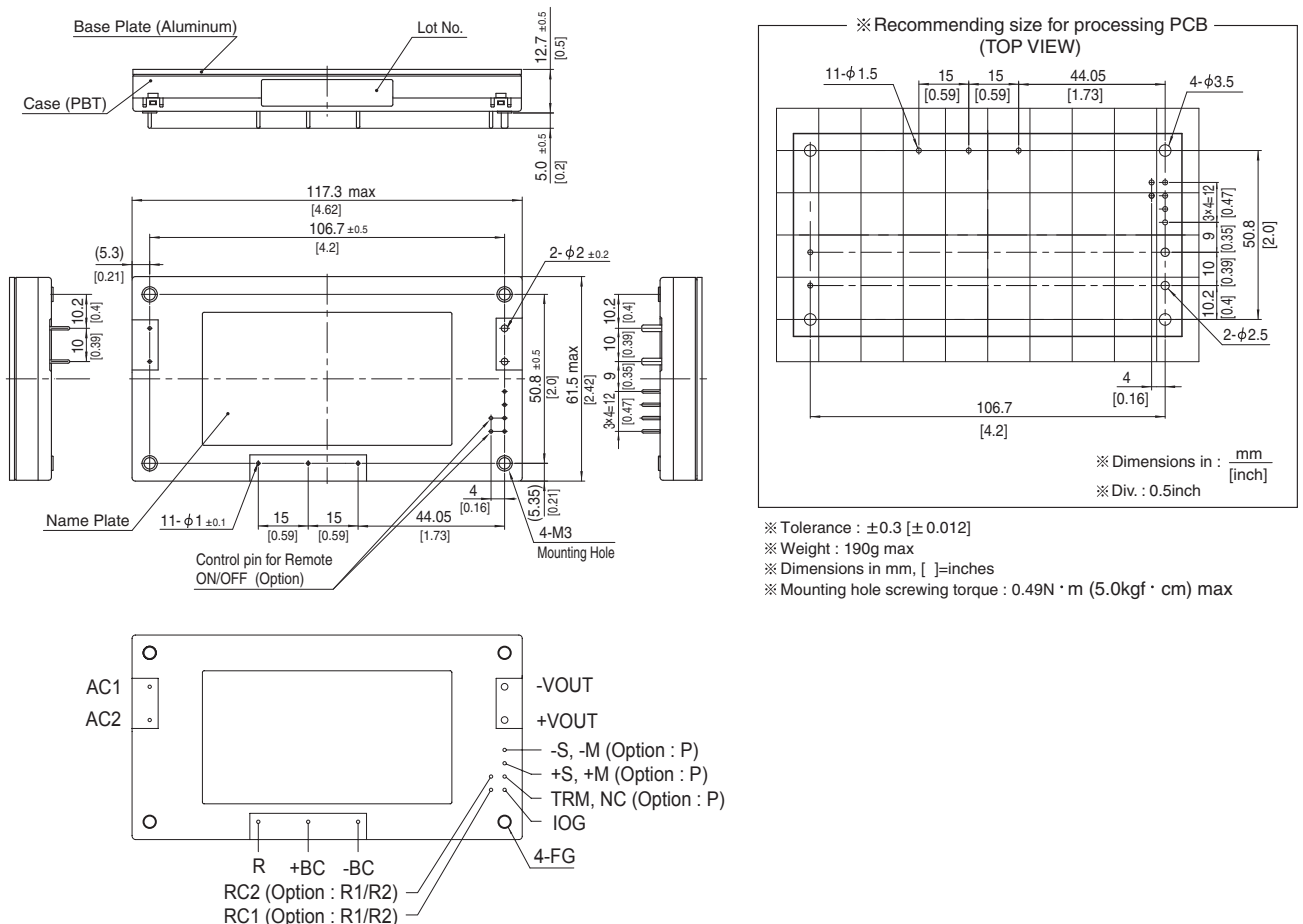

TUNS1200F

TUN S 1200 F 48 -□

① ② ③ ④ ⑤ ⑥

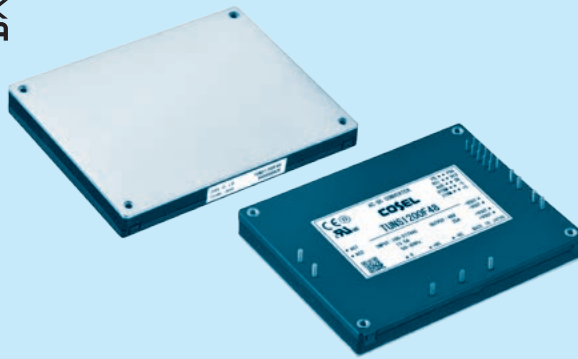

- ① Series name
- ② Single output
- ③ Output wattage
- ④ Universal Input
- ⑤ Output voltage
- ⑥ Optional
 - T : with Mounting hole (φ 3.4 thru)
 - Y1: Output voltage adjustment range ±20% (Only 48V)
 - R3: with Remote ON/OFF (Positive logic control)
 - N1: Auto restart from thermal protection

* Avoid short circuit between +BC/R and -BC. It may cause the failure of inside components.
 * Keep VTRM open, if output voltage adjustment is not necessary.
 * Keep ITRM open, if output current adjustment is not necessary.
 * If remote sensing is not necessary, connect between +Vout & +S and between -Vout & -S.

MODEL	TUNS1200F12	TUNS1200F28	TUNS1200F48	TUNS1200F65
MAX OUTPUT WATTAGE[W]	1008	1204	1200	1202.5
DC OUTPUT	12V 84A	28V 43A	48V 25A	65V 18.5A

SPECIFICATIONS

	MODEL	TUNS1200F12	TUNS1200F28	TUNS1200F48	TUNS1200F65	
INPUT	VOLTAGE[V]	AC85 - 305V 1 φ				
	CURRENT[A]	ACIN 100V	12typ	14typ	14typ	14typ
		ACIN 200V	5.9typ	6.7typ	6.6typ	6.7typ
	FREQUENCY[Hz]	50/60 (47 - 63)				
	EFFICIENCY[%]	ACIN 100V	85typ	89typ	90typ	89typ
		ACIN 200V	87typ	91typ	92typ	91typ
	POWER FACTOR (I _o =100%)	ACIN 100V	0.98typ			
		ACIN 200V	0.95typ			
INRUSH CURRENT	Limited by external resistance					
LEAKAGE CURRENT[ma]	0.5max (ACIN 240V 60Hz, I _o =100%, According to IEC60601-1)					
OUTPUT	VOLTAGE[V]	12	28	48	65	
	CURRENT[A]	84	43	25	18.5	
	LINE REGULATION[mV]	24max	56max	96max	130max	
	LOAD REGULATION[mV]	24max	56max	96max	130max	
	RIPPLE[mVp-p]	0 to +100°C *1	150max	180max	250max	350max
		-40 to 0°C *1	180max	200max	300max	400max
	RIPPLE NOISE[mVp-p]	0 to +100°C *1	180max	200max	300max	400max
		-40 to 0°C *1	200max	300max	450max	450max
	TEMPERATURE REGULATION[mV]	0 to +80°C *1	120max	280max	480max	650max
		-40 to +100°C *1	240max	560max	960max	1300max
	DRIFT[mV]	*2	40max	90max	180max	240max
	OUTPUT VOLTAGE ADJUSTMENT RANGE[V]	Fixed (VTRM pin open), adjustable by external resistor or external signal				
OUTPUT VOLTAGE SETTING[V]	9.60 - 14.40	22.40 - 33.60	38.40 - 52.80 (Y1:38.4 - 57.6)	52.00 - 78.00		
OUTPUT VOLTAGE SETTING[V]	11.91 - 12.29	27.56 - 28.44	47.24 - 48.76	63.96 - 66.04		
PROTECTION CIRCUIT AND OTHERS	OVERCURRENT PROTECTION	Works over 105% of rating and recovers automatically				
	OVERVOLTAGE PROTECTION[V]	15.00 - 16.80	35.00 - 39.20	55.20 - 60.00 (Y1:60.0 - 67.2)	81.25 - 91.00	
	REMOTE SENSING	Provided				
	REMOTE ON/OFF	Provided				
ISOLATION	INPUT-OUTPUT	AC3,000V 1minute, Cutoff current = 10mA, DC500V 50MΩ min (20±15°C) 2MOOP				
	INPUT-FG	AC2,000V 1minute, Cutoff current = 10mA, DC500V 50MΩ min (20±15°C) 1MOOP				
	OUTPUT-FG	TUNS1200F12/28/48 : AC500V 1minute, Cutoff current = 100mA, DC500V 50MΩ min (20±15°C) TUNS1200F65 : AC1,200V 1minute, Cutoff current = 10mA, DC500V 50MΩ min (20±15°C) 1MOOP				
OUTPUT-RC, PG	AC100V 1minute, Cutoff current = 100mA, DC100V 10MΩ min (20±15°C)					
ENVIRONMENT	OPERATING TEMP., HUMID. AND ALTITUDE	-40 to +100°C (On aluminum base plate), 20 - 95%RH (Non condensing) (Refer to DERATING CURVE)				
	STORAGE TEMP., HUMID. AND ALTITUDE	-40 to +100°C, 20 - 95%RH (Non condensing), 9,000m (30,000 feet) max				
	VIBRATION	10 - 55Hz, 49.0m/s ² (5G), 3minutes period, 60minutes each along X, Y and Z axis				
IMPACT	196.1m/s ² (20G), 11ms, once each along X, Y and Z axis					
SAFETY AND NOISE REGULATIONS	AGENCY APPROVALS	UL62368-1, EN62368-1, C-UL (equivalent to CAN/CSA-C22.2 No.62368-1), ANSI/AAMI ES60601-1, EN60601-1 3rd, C-UL (equivalent to CAN/CSA-C22.2 No.60601-1), Complies with IEC60601-1-2 4th				
	HARMONIC ATTENUATOR	Complies with IEC61000-3-2 (Class A) *3				
OTHERS	CASE SIZE/WEIGHT	117.3 X 12.7 X 86.8mm [4.62 X 0.5 X 3.42 inches] (W X H X D) / 280g max				
	COOLING METHOD	Conduction cooling (e.g. heat radiation from the aluminum base plate to the attached heat sink)				

*1 Refer to instruction manual for measuring method of electric characteristics.
 *2 Drift is the change in DC output for an eight hour period after a half-hour warm-up at 25°C, with the input voltage held constant at the rated input/output.
 *3 Please contact us about another class.

External view

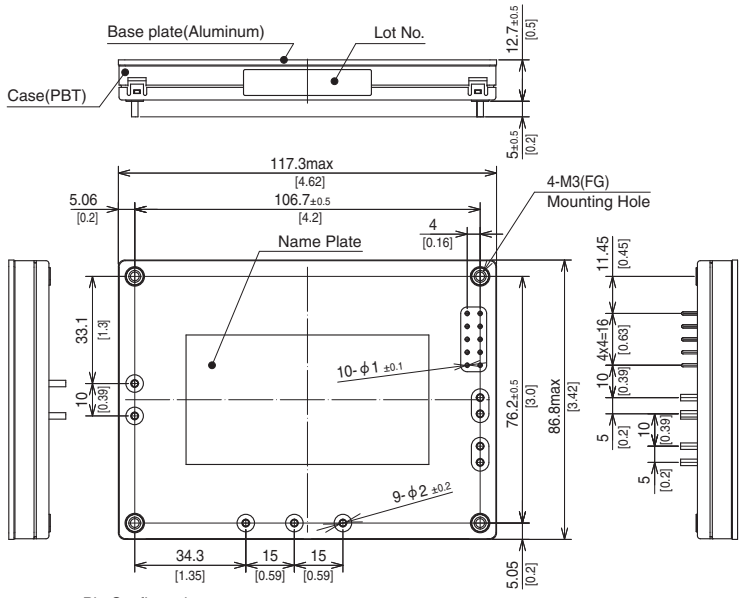

Pin Configuration

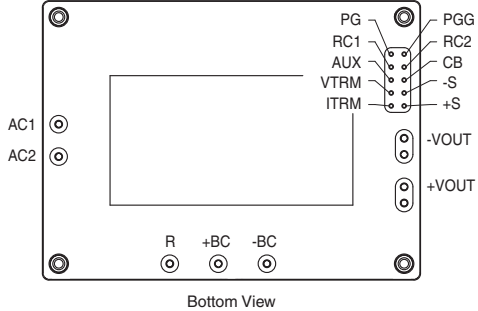

Bottom View

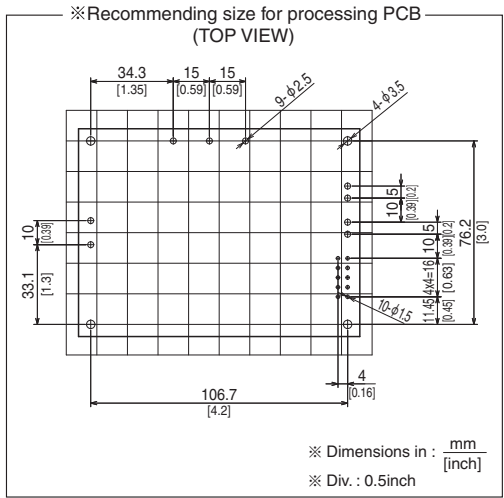

※ Dimensions in : mm [inch]
※ Div. : 0.5inch

- ※ Tolerance : ±0.3 [±0.012]
- ※ Weight : 280g max
- ※ Dimensions in mm, []=inches
- ※ Mounting hole screwing torque : 0.49N · m (5.0kgf · cm) max

Pin Configuration

● TUNS50F

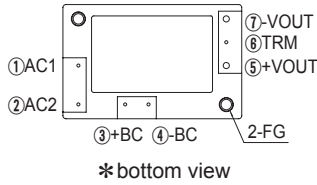

● TUNS100F

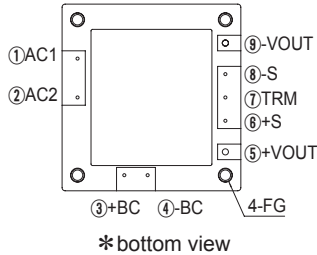

● TUNS300F/TUNS500F/TUNS700F

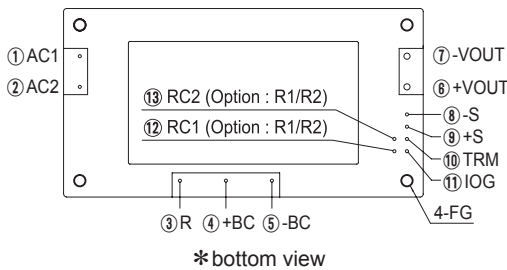

● TUNS700F□□-P (OPTION)

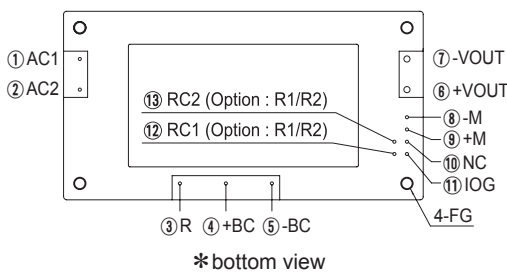

● TUNS1200F

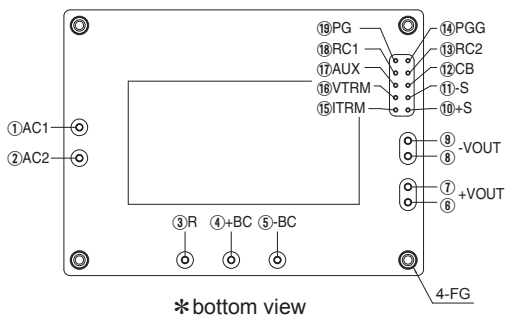

No.		Pin Connection	Function
TUNS50F	TUNS100F		
①	①	AC1	AC input
②	②	AC2	
③	③	+BC	+BC output
④	④	-BC	-BC output
⑤	⑤	+VOUT	+DC output
⑦	⑨	-VOUT	-DC output
-	⑧	-S	Remote sensing (-)
-	⑥	+S	Remote sensing (+)
⑥	⑦	TRM	Adjustment of output voltage
-	-	FG	Mounting hole (FG)

No.	Pin Connection	Function
①	AC1	AC input
②	AC2	
③	R	External resistor for inrush current protection
④	+BC	+BC output
⑤	-BC	-BC output
⑥	+VOUT	+DC output
⑦	-VOUT	-DC output
⑧	-S	Remote sensing (-)
⑨	+S	Remote sensing (+)
⑩	TRM	Adjustment of output voltage
⑪	IOG	Inverter operation monitor
⑫	RC1	Remote ON/OFF (Option)
⑬	RC2	Remote ON/OFF (Option)
-	FG	Mounting hole (FG)

No.	Pin Connection	Function
⑧	-M	Output voltage monitor terminal
⑨	+M	
⑩	NC	No connection

Other than the above are the same as standard products.

No.	Pin Connection	Function
①	AC1	AC input
②	AC2	
③	R	External resistor for inrush current protection
④	+BC	+BC output
⑤	-BC	-BC output
⑥⑦	+VOUT	+DC output
⑧⑨	-VOUT	-DC output
⑩	+S	Remote sensing (+)
⑪	-S	Remote sensing (-)
⑫	CB	Current balance
⑬	RC2	Remote ON/OFF ground
⑭	PGG	Power good output ground
⑮	ITRM	Adjustment of output current
⑯	VTRM	Adjustment of output voltage
⑰	AUX	Auxiliary output
⑱	RC1	Remote ON/OFF
⑲	PG	Power good output
-	FG	Mounting hole (FG)

Implementation • Mounting Method

Mounting method

- Use with the conduction cooling (e.g. heat dissipation from the aluminum base plate to the attached heat sink).
- Use a heat sink that larger than the power supply and has a large thickness so that the aluminum base plate can be cooled uniformly.
- The unit can be mounted in any direction. When two or more power supplies are used side by side, position them with proper intervals to allow enough air ventilation. Aluminum base plate temperature of each power supply should not exceed the temperature range shown in “derating”.
- Avoid placing the AC input line pattern layout underneath the unit. It will increase the line conducted noise. Make sure to leave an ample distance between the line pattern layout and the unit. Also avoid placing the DC output line pattern underneath the unit because it may increase the output noise. Lay out the pattern away from the unit.
- Avoid placing the signal line pattern layout underneath the unit because the power supply might become unstable. Lay out the pattern away from the unit.
- High-frequency noise radiates directly from the unit to the atmosphere. Therefore, design the shield pattern on the printed circuit board and connect it to FG or -BC. The shield pattern prevents noise radiation.
- When a heat sink cannot be fixed on the base plate side, order the power module with “-T” option. A heat sink can be mounted by affixing a M3 tap on the heat sink. Please make sure a mounting hole will be connected to a grounding capacitor CY.

	Mounting hole
Standard	M3 tapped
Optional : -T	φ 3.4 thru

Stress onto the pins

- When too much stress is applied to the pins may damage internal connections. Avoid applying stress in excess of that shown in right figure.
- The pins are soldered onto the internal PCB. Therefore, Do not bend or pull the leads with excessive force.
- Mounting hole diameter of PCB should be 3.5mm to reduce the stress to the pins.
- Fix the unit on PCB (fixing fittings) by screws to reduce the stress to the pins. Be sure to mount the unit first, then solder the unit.

● TUNS50F/100F/300F/500F/700F

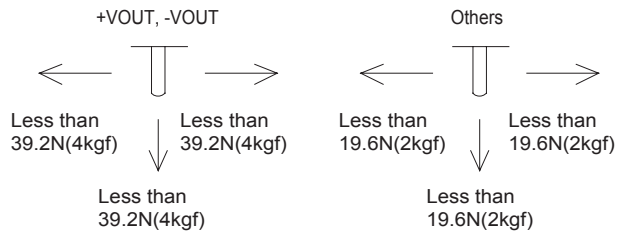

● TUNS1200F

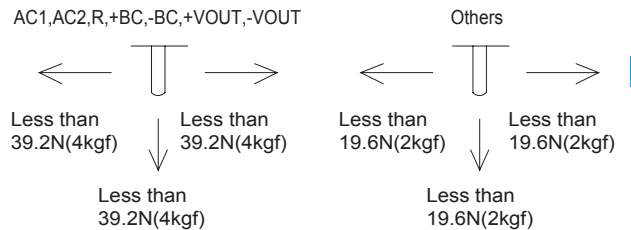

Soldering temperature

- Flow soldering : 260°C for up to 15 seconds.
- Soldering iron (26W) : 450°C for up to 5 seconds.

Derating

Input voltage derating curve

● TUNS50F/100F

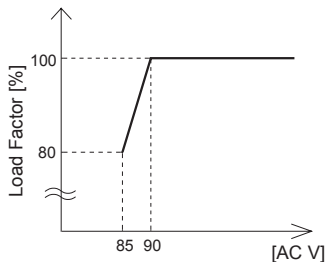

● TUNS700F/1200F

* TUNS1200F12 has no input voltage derating.

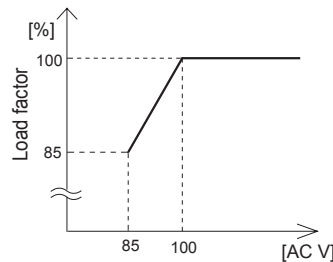

● TUNS300F/500F

* TUNS300F/500F has no input voltage derating.

Derating

Output voltage derating curve

■ Use the power modules with conduction cooling (e.g. heat dissipation from the aluminum base plate to the attached heat sink).

Below shows the derating curves with respect to the aluminum base plate temperature. Note that operation within the hatched areas will cause a significant level of ripple and ripple noise.

■ Please measure the temperature on the aluminum base plate edge side when you cannot measure the temperature of the center part of the aluminum base plate. In this case, please take 5deg temperature margin from the derating characteristics shown in below. Please reduce the temperature fluctuation range as much as possible when the up and down of the temperature are frequently generated. Contact us for more information on cooling methods.

● TUNS50F/100F

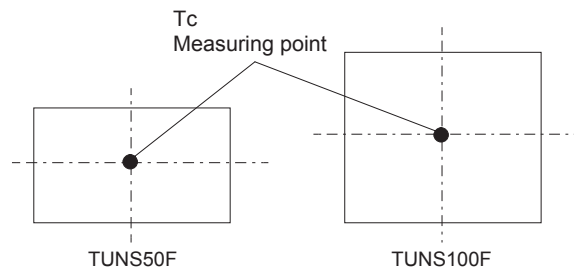
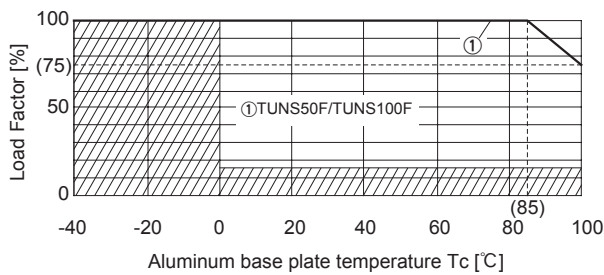

● TUNS300F

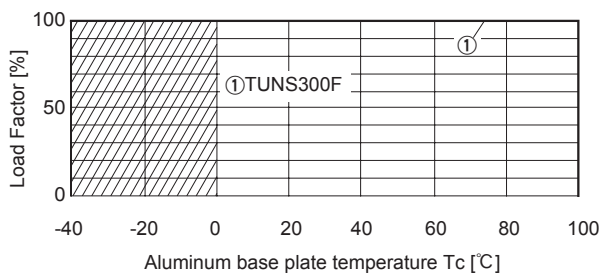

● TUNS500F

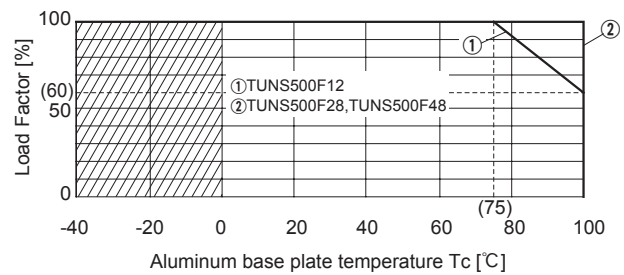

● TUNS700F

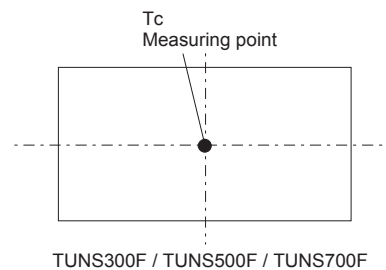
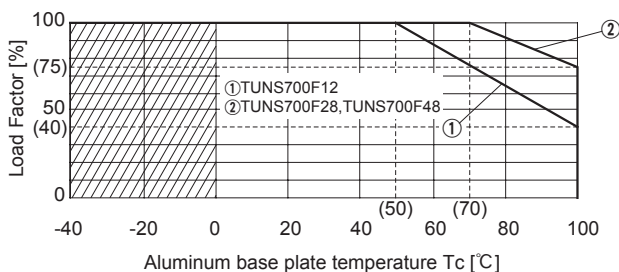

● TUNS1200F

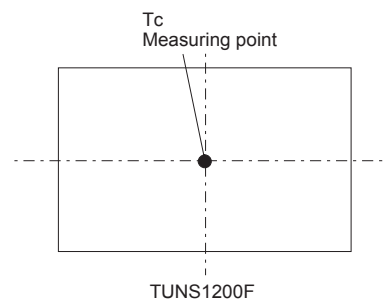
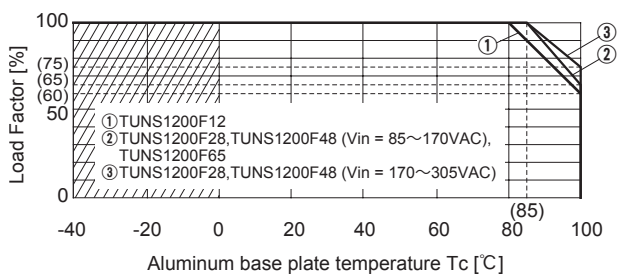

Instruction Manual

◆ It is necessary to read the “Instruction Manual” and “Before using our product” before you use our product.

Instruction Manual <https://www.cosel.co.jp/redirect/catalog/en/TUNS/>
 Before using our product <https://en.cosel.co.jp/technical/caution/index.html>

TUNS



NOTICE



Basic Characteristics Data

Model	Circuit method	Switching frequency [kHz]	Input current [A] *1	Inrush current protection circuit	PCB/Pattern			Series/Parallel operation availability	
					Material	Single sided	Double sided	Series operation	Parallel operation
TUNS50F	Active filter	80-600	0.67	Thermistor	Aluminum	Yes		Yes	*2
	Flyback converter	100-300							
TUNS100F	Active filter	80-600	1.3	Thermistor	Aluminum	Yes		Yes	*2
	Forward converter	300							
TUNS300F	Active filter	100	3.6	SCR	Aluminum	Yes		Yes	*2
	Half-bridge converter	400							
TUNS500F	Active filter	100	6.0	SCR	Aluminum	Yes		Yes	*2
	Half-bridge converter	400							
TUNS700F	Active filter	100	8.6	SCR	Aluminum	Yes		Yes	*2
	Half-bridge converter	400							
TUNS1200F	Active filter	100	14	SCR	Aluminum	Yes		Yes	Yes
	Full-bridge converter	400							

*1 The value of input current is at ACIN 100V and rated load.

*2 Refer to instruction manual.



TUXS-series

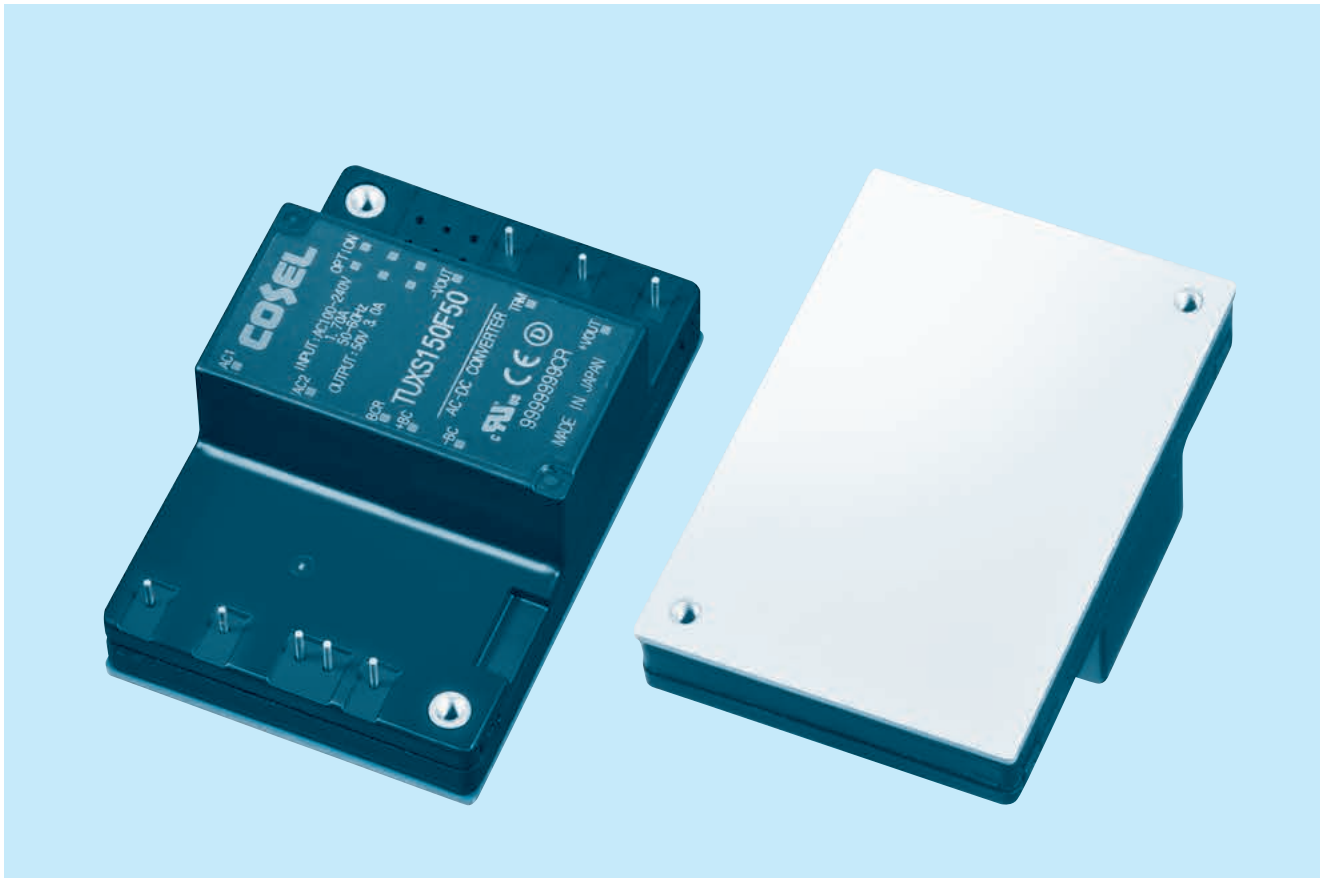

TUXS

Feature

- AC-DC Power Module Type Converter
- Harmonic attenuator (Complies with IEC61000-3-2 class A)
- Small size
- Built-in overcurrent, overvoltage and thermal protection circuits
- Mounting hole (M3 tapped)
- High efficiency 94%

CE marking

- Low voltage directive
- RoHS Directive

UKCA marking

- Electrical Equipment Safety Regulations
- RoHS Regulations

Safety Approval

- UL60950-1, C-UL, EN62368-1

5-year warranty

TUXS150F

TUX S 150 F 50 -□

① ② ③ ④ ⑤ ⑥

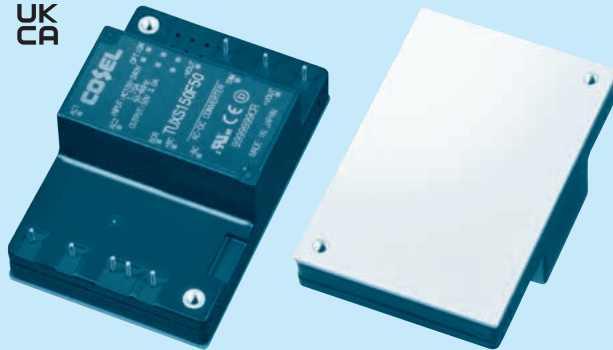

- ① Series name
- ② Single output
- ③ Output wattage
- ④ Universal Input
- ⑤ Output voltage
- ⑥ Optional
 - T : with Mounting hole (φ 3.4 thru)
 - N : Auto restart in protection circuit working

* Avoid short circuit between +BC and -BC. It may cause the failure of inside components.
 * Keep TRM open, if output voltage adjustment is not necessary.

MODEL	TUXS150F50
MAX OUTPUT WATTAGE[W]	150.0
DC OUTPUT	50V 3A

SPECIFICATIONS

MODEL		TUXS150F50	
INPUT	VOLTAGE[V]	AC85 - 264 1 φ	
	CURRENT[A]	ACIN 100V	1.70typ (Io=100%)
		ACIN 200V	0.80typ (Io=100%)
	FREQUENCY[Hz]	50/60 (45 - 66)	
	EFFICIENCY[%]	ACIN 100V	93typ
		ACIN 200V	94typ
	POWER FACTOR (Io=100%)	ACIN 100V	0.96typ
		ACIN 200V	0.93typ
	INRUSH CURRENT	Limited by external components (Thermistor)	
	LEAKAGE CURRENT[mA]	0.75max (ACIN 240V 60Hz, Io=100%, According to IEC62368-1)	
OUTPUT	VOLTAGE[V]	50	
	CURRENT[A]	3	
	LINE REGULATION[mV]	100max	
	LOAD REGULATION[mV]	100max	
	RIPPLE[mVp-p]	-20 to +100°C *1	200max
		-40 to -20°C *1	300max
	RIPPLE NOISE[mVp-p]	-20 to +100°C *1	200max
		-40 to -20°C *1	300max
	TEMPERATURE REGULATION[mV]	0 to +100°C	500max
		-40 to +100°C	1000max
DRIFT[mV]	*2	200max	
OUTPUT VOLTAGE ADJUSTMENT RANGE[V]	Fixed (TRM pin open), adjustable by external resistor or external signal 45.0 - 55.0		
OUTPUT VOLTAGE SETTING[V]	49.2 - 50.8		
PROTECTION CIRCUIT AND OTHERS	OVERCURRENT PROTECTION	Works over 105% of rating and recovers automatically	
	OVERVOLTAGE PROTECTION[V]	57.5 - 67.5	
	REMOTE SENSING	Not provided	
	REMOTE ON/OFF	Not provided	
ISOLATION	INPUT-OUTPUT	AC3,000V 1minute, Cutoff current = 10mA, DC500V 50MΩ min (20±15°C)	
	INPUT-FG	AC2,000V 1minute, Cutoff current = 10mA, DC500V 50MΩ min (20±15°C)	
	OUTPUT-FG	AC500V 1minute, Cutoff current = 100mA, DC500V 50MΩ min (20±15°C)	
ENVIRONMENT	OPERATING TEMP., HUMID. AND ALTITUDE	-40 to +100°C (On aluminum base plate), 20 - 95%RH (Non condensing) (Refer to "Derating"), 4,000m (13,000 feet) max	
	STORAGE TEMP., HUMID. AND ALTITUDE	-40 to +100°C, 20 - 95%RH (Non condensing), 9,000m (30,000 feet) max	
	VIBRATION	10 - 55Hz, 49.0m/s ² (5G), 3minutes period, 60minutes each along X, Y and Z axis	
	IMPACT	196.1m/s ² (20G), 11ms, once each along X, Y and Z axis	
SAFETY AND NOISE REGULATIONS	AGENCY APPROVALS	UL60950-1, C-UL (CSA60950-1), EN62368-1	
	HARMONIC ATTENUATOR	Complies with IEC61000-3-2 (Class A) *3	
OTHERS	CASE SIZE/WEIGHT	76.2×28.5×50.8mm [3.0×1.12×2.0 inches] (W×H×D) / 150g max	
	COOLING METHOD	Conduction cooling (e.g. heat radiation from the aluminum base plate to the attached heat sink)	

*1 Refer to instruction manual for measuring method of electric characteristics.
 *2 Drift is the change in DC output for an eight hour period after a half-hour warm-up at 25°C, with the input voltage held constant at the rated input/output.
 *3 Please contact us about another class.

External view

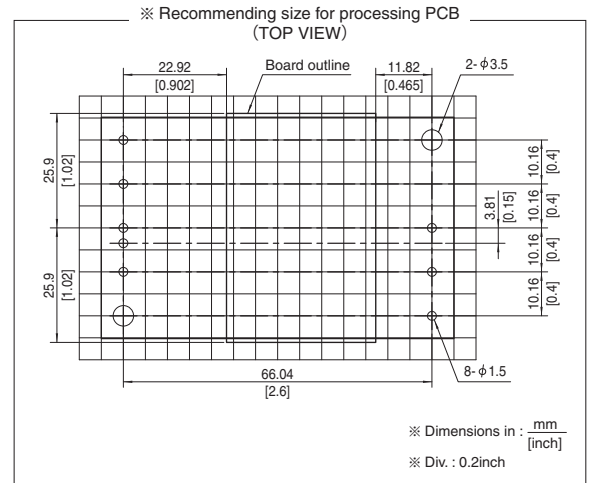
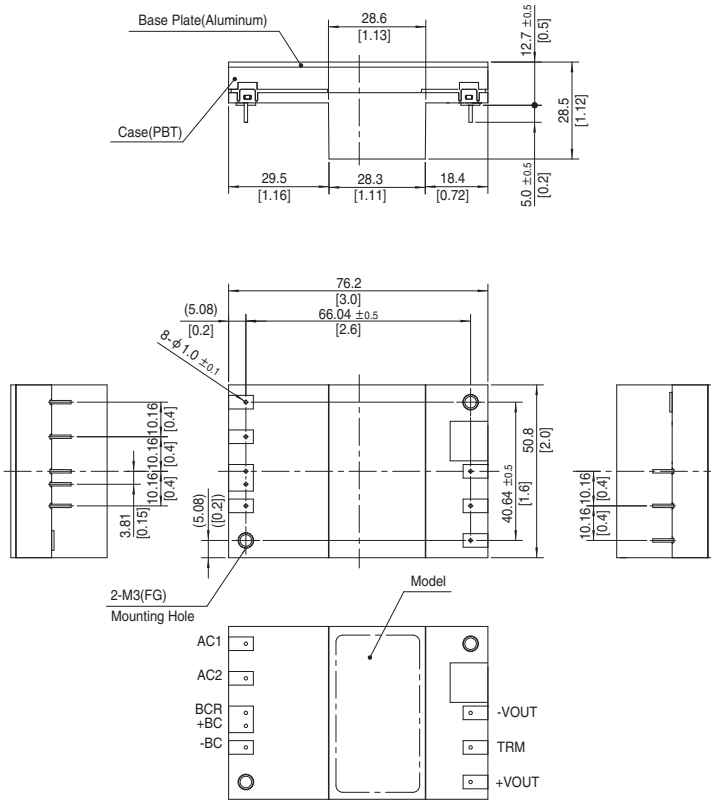

- ※ Tolerance : ± 0.3 [± 0.012]
- ※ Weight : 150g max
- ※ Dimensions in mm, []=inches
- ※ Mounting hole screwing torque : 0.49N/m (5.0kgf/cm) max

TUXS200F

TUX S 200 F 50 -□

① ② ③ ④ ⑤ ⑥

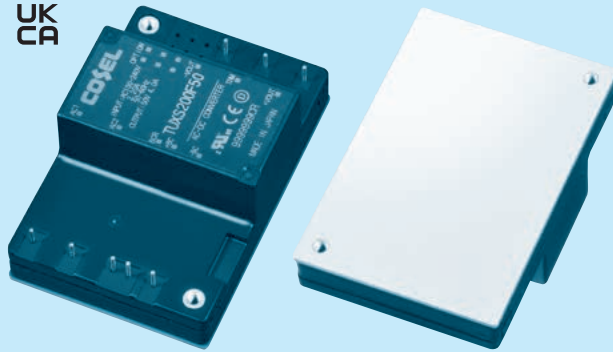

- ① Series name
- ② Single output
- ③ Output wattage
- ④ Universal Input
- ⑤ Output voltage
- ⑥ Optional
 - T : with Mounting hole (φ 3.4 thru)
 - N : Auto restart in protection circuit working

* Avoid short circuit between +BC and -BC. It may cause the failure of inside components.
 * Keep TRM open, if output voltage adjustment is not necessary.

MODEL	TUXS200F24	TUXS200F28	TUXS200F32	TUXS200F42	TUXS200F50
MAX OUTPUT WATTAGE[W]	199.2	196.0	198.4	197.4	200.0
DC OUTPUT	24V 8.3A	28V 7.0A	32V 6.2A	42V 4.7A	50V 4.0A

SPECIFICATIONS

	MODEL	TUXS200F24	TUXS200F28	TUXS200F32	TUXS200F42	TUXS200F50	
INPUT	VOLTAGE[V]	AC85 - 264 1 φ					
	CURRENT[A]	ACIN 100V	2.20typ (Io=100%)				
		ACIN 200V	1.10typ (Io=100%)				
	FREQUENCY[Hz]	50/60 (45 - 66)					
	EFFICIENCY[%]	ACIN 100V	90typ	90typ	91typ	91typ	92typ
		ACIN 200V	91typ	91typ	92typ	92typ	93typ
	POWER FACTOR (Io=100%)	ACIN 100V	0.96typ				
		ACIN 200V	0.93typ				
	INRUSH CURRENT	Limited by external components (Thermistor)					
	LEAKAGE CURRENT[ma]	0.75max (ACIN 240V 60Hz, Io=100%, According to IEC62368-1)					
OUTPUT	VOLTAGE[V]	24	28	32	42	50	
	CURRENT[A]	8.3	7.0	6.2	4.7	4.0	
	LINE REGULATION[mV]	48max	56max	64max	84max	100max	
	LOAD REGULATION[mV]	48max	56max	64max	84max	100max	
	RIPPLE[mVp-p]	-20 to +100°C *1	144max	168max	192max	252max	300max
		-40 to -20°C *1	192max	224max	256max	336max	400max
	RIPPLE NOISE[mVp-p]	-20 to +100°C *1	144max	168max	192max	252max	300max
		-40 to -20°C *1	192max	224max	256max	336max	400max
	TEMPERATURE REGULATION[mV]	0 to +100°C	240max	280max	320max	420max	500max
		-40 to +100°C	480max	560max	640max	820max	1000max
	DRIFT[mV]	*2	96max	112max	128max	168max	200max
	OUTPUT VOLTAGE ADJUSTMENT RANGE[V]	Fixed (TRM pin open), adjustable by external resistor or external signal					
OUTPUT VOLTAGE SETTING[V]	21.60 - 26.40	25.20 - 30.80	28.80 - 35.20	37.80 - 46.20	45.00 - 55.00		
	23.62 - 24.38	27.55 - 28.45	31.49 - 32.51	41.33 - 42.67	49.20 - 50.80		
PROTECTION CIRCUIT AND OTHERS	OVERCURRENT PROTECTION	Works over 105% of rating and recovers automatically					
	OVERVOLTAGE PROTECTION[V]	27.60 - 28.80	32.20 - 33.60	36.80 - 38.40	48.30 - 50.40	57.50 - 60.00	
	REMOTE SENSING	Not provided					
	REMOTE ON/OFF	Not provided					
ISOLATION	INPUT-OUTPUT	AC3,000V 1minute, Cutoff current = 10mA, DC500V 50MΩ min (20±15°C)					
	INPUT-FG	AC2,000V 1minute, Cutoff current = 10mA, DC500V 50MΩ min (20±15°C)					
	OUTPUT-FG	AC500V 1minute, Cutoff current = 100mA, DC500V 50MΩ min (20±15°C)					
ENVIRONMENT	OPERATING TEMP., HUMID. AND ALTITUDE	-40 to +100°C (On aluminum base plate), 20 - 95%RH (Non condensing) (Refer to "Derating"), 4,000m (13,000 feet) max					
	STORAGE TEMP., HUMID. AND ALTITUDE	-40 to +100°C, 20 - 95%RH (Non condensing), 9,000m (30,000 feet) max					
	VIBRATION	10 - 55Hz, 49.0m/s ² (5G), 3minutes period, 60minutes each along X, Y and Z axis					
	IMPACT	196.1m/s ² (20G), 11ms, once each along X, Y and Z axis					
SAFETY AND NOISE REGULATIONS	AGENCY APPROVALS	UL60950-1, C-UL (CSA60950-1), EN62368-1					
	HARMONIC ATTENUATOR	Complies with IEC61000-3-2 (Class A) *3					
OTHERS	CASE SIZE/WEIGHT	76.2×28.5×50.8mm [3.0×1.12×2.0 inches] (W×H×D) / 150g max					
	COOLING METHOD	Conduction cooling (e.g. heat radiation from the aluminum base plate to the attached heat sink)					

*1 Refer to instruction manual for measuring method of electric characteristics.
 *2 Drift is the change in DC output for an eight hour period after a half-hour warm-up at 25°C, with the input voltage held constant at the rated input/output.
 *3 Please contact us about another class.

External view

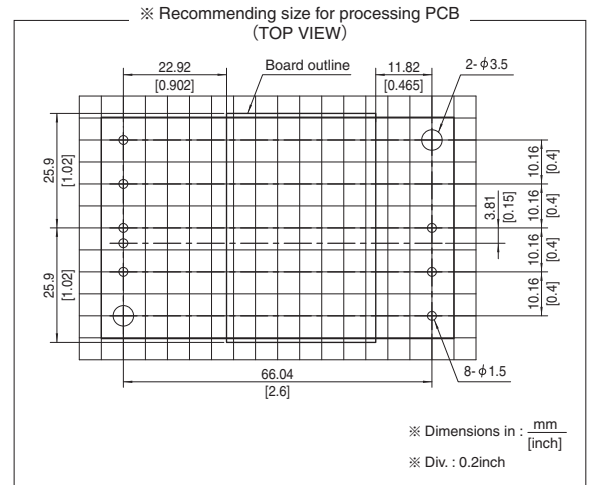
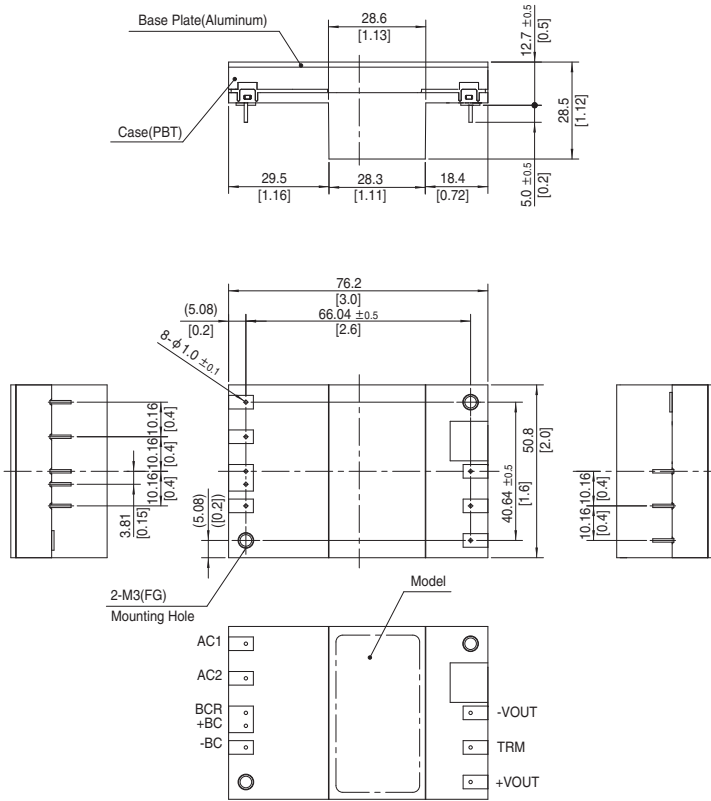

- ※ Tolerance : ± 0.3 [± 0.012]
- ※ Weight : 150g max
- ※ Dimensions in mm, []=inches
- ※ Mounting hole screwing torque : 0.49N/m (5.0kgf/cm) max

Pin Configuration

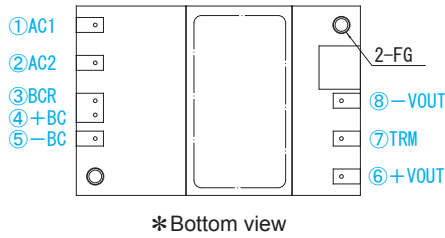

No.	Pin Connection	Function
①	AC1	AC input
②	AC2	
③	BCR	+BC output
④	+BC	+BC output
⑤	-BC	-BC output
⑥	+VOUT	+DC output
⑦	TRM	Adjustment of output voltage
⑧	-VOUT	-DC output
-	FG	Mounting hole (FG)

Implementation • Mounting Method

Mounting method

- The unit can be mounted in any direction. When two or more power supplies are used side by side, position them with proper intervals to allow enough air ventilation. Aluminum base plate temperature of each power supply should not exceed the temperature range shown in "Derating".
- Avoid placing the AC input line pattern layout underneath the unit. It will increase the line conducted noise. Make sure to leave an ample distance between the line pattern layout and the unit. Also avoid placing the DC output line pattern underneath the unit because it may increase the output noise. Lay out the pattern away from the unit.
- Avoid placing the signal line pattern layout underneath the unit because the power supply might become unstable. Lay out the pattern away from the unit.
- High-frequency noise radiates directly from the unit to the atmosphere. Therefore, design the shield pattern on the printed circuit board and connect it to FG.
The shield pattern prevents noise radiation.
- When a heat sink cannot be fixed on the base plate side, order the power module with "-T" option. A heat sink can be mounted by affixing a M3 tap on the heat sink. Please make sure a mounting hole will be connected to a grounding capacitor CY.

Mounting hole	
Standard	M3 tapped
Optional : -T	φ 3.4 thru

Stress onto the pins

- When too much stress is applied to the pins may damage internal connections. Avoid applying stress in excess of that shown in right figure.
- The pins are soldered onto the internal PCB.
Therefore, Do not bend or pull the leads with excessive force.
- Mounting hole diameter of PCB should be 3.5mm to reduce the stress to the pins.
- Fix the unit on PCB (fixing fittings) by screws to reduce the stress to the pins. Be sure to mount the unit first, then solder the unit.

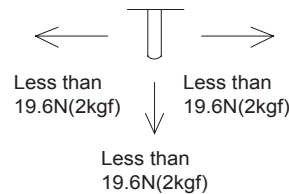

Soldering

- Flow soldering : 260°C less than 15 seconds.
- Soldering iron (26W) : 450°C less than 5 seconds.

Derating

Output voltage derating curve

- Use the power modules with conduction cooling (e.g. heat dissipation from the aluminum base plate to the attached heat sink). Below shows the derating curves with respect to the aluminum base plate temperature. Note that operation within the hatched areas will cause a significant level of ripple and ripple noise.
- Please measure the temperature on the aluminum base plate edge side when you cannot measure the temperature of the center part of the aluminum base plate. In this case, please take 5deg temperature margin from the derating characteristics shown in Below. Please reduce the temperature fluctuation range as much as possible when the up and down of the temperature are frequently generated. Contact us for more information on cooling methods.

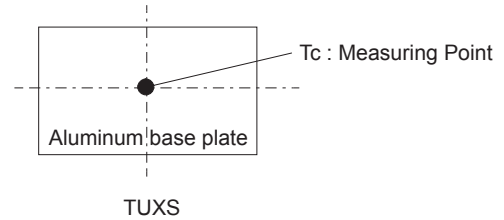
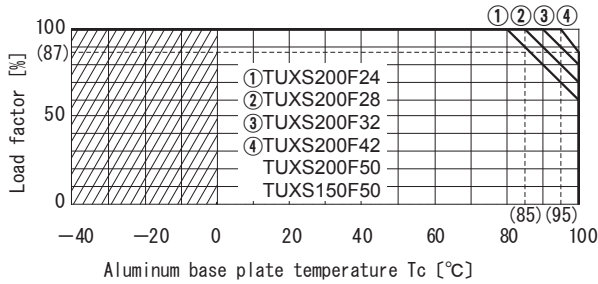

Instruction Manual

- ◆ It is necessary to read the "Instruction Manual" and "Before using our product" before you use our product.

Instruction Manual <https://www.cosel.co.jp/redirect/catalog/en/TUXS/>
 Before using our product <https://en.cosel.co.jp/technical/caution/index.html>

TUXS



NOTICE



Basic Characteristics Data

TUXS

Model	Circuit method	Switching frequency [kHz]	Input current [A] *1	Inrush current protection circuit	PCB/Pattern			Series/Parallel operation availability	
					Material	Single sided	Double sided	Series operation	Parallel operation
TUXS150F	Active filter	80-600	1.70	Thermistor	Aluminum	Yes		Yes	*2
	LLC resonant converter	100-300							
TUXS200F	Active filter	80-600	2.20	Thermistor	Aluminum	Yes		Yes	*2
	LLC resonant converter	100-300							

*1 The value of input current is at ACIN 100V and rated load.
 *2 Refer to instruction manual.

Power
Factor
CorrectionWorld
wideLow
ProfileSafety
ApprovalsInrush
current
limiting

OVP

DPG-series

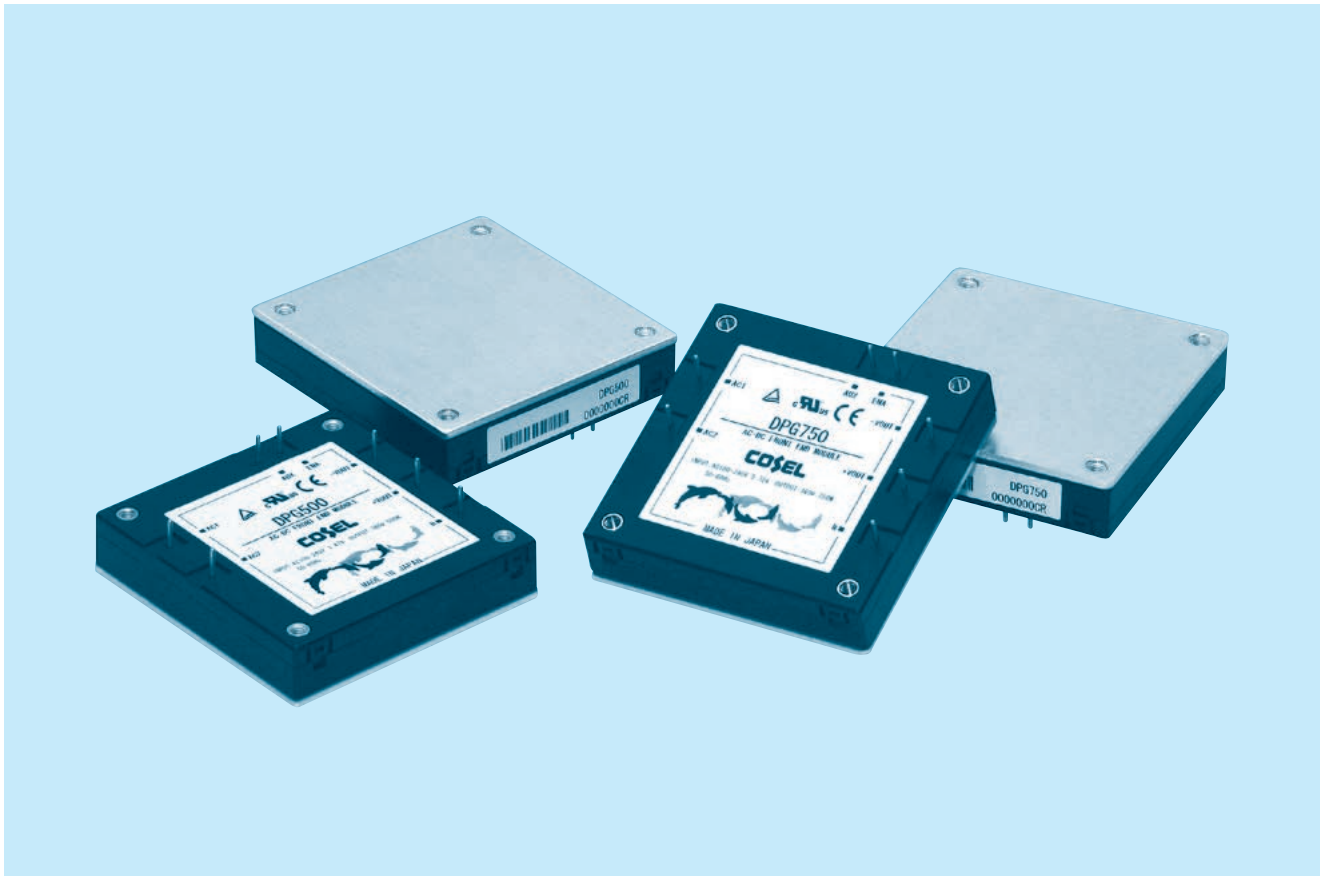

■ Power factor correction module

■ Feature

- Harmonic attenuator (Complies with IEC61000-3-2)
- High efficiency 93% (AC100V), 96% (AC200V)
- Universal input voltage (AC85 - 264V)
- Built-in inrush current protection
- Built-in overvoltage and thermal protection circuits
- Enable signal (ENA)
- Auxiliary power supply for external signal (AUX)
- Ideal for distributed power systems

■ 5-year warranty

■ CE marking

- Low Voltage Directive
- RoHS Directive

■ UKCA marking

- Electrical Equipment Safety Regulations
- RoHS Regulations

■ Safety agency approvals

- UL, C-UL recognized, TÜV approved

DPG

DPG 750 -□

① ② ③



- ① Series name
- ② Output power
500 : 500W (ACIN 200V)
750 : 750W (ACIN 200V)
- ③ Optional
T : with Mounting hole
(φ 3.4 thru)

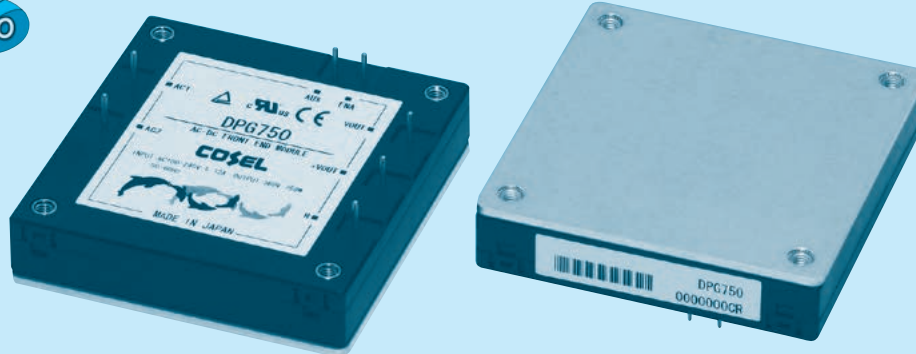

MODEL	DPG500		DPG750	
AC INPUT[V]	AC85 - 264	AC170 - 264	AC85 - 264	AC170 - 264
MAX OUTPUT WATTAGE[W]	*1 300	500	500	750
DC OUTPUT VOLTAGE[V]	*2 360			

SPECIFICATIONS

	MODEL	DPG500		DPG750	
INPUT	VOLTAGE[V]	AC85 - 264 1 φ	AC170 - 264 1 φ	AC85 - 264 1 φ	AC170 - 264 1 φ
	POWER FACTOR CORRECTION RANGE[V]	AC85 - 264 1 φ			
	CURRENT[A]	3.47typ (ACIN 100V)	2.86typ (ACIN 200V)	5.72typ (ACIN 100V)	4.24typ (ACIN 200V)
	FREQUENCY[Hz]	50/60 (47 - 63) Hz			
	INRUSH CURRENT[A]	Limited by external resistance			
	EFFICIENCY[%]	92typ (ACIN 100V)	95typ (ACIN 200V)	93typ (ACIN 100V)	96typ (ACIN 200V)
	POWER FACTOR	0.96typ (ACIN 100V)	0.93typ (ACIN 200V)	0.96typ (ACIN 100V)	0.93typ (ACIN 200V)
	LEAKAGE CURRENT[ma]	0.75 max (60Hz, According to IEC62368-1 and DEN-AN)			
OUTPUT	WATTAGE[W]	*1 300	500	500	750
	VOLTAGE[V]	*2 360			
	VOLTAGE ACCURACY	*3 ±2%			
PROTECTION CIRCUIT AND OTHERS	OVERVOLTAGE PROTECTION[V]	DC400 - 450V The power factor corrector function stops			
	ENA	*4	Enable signal, Open-drain output, Maximum sink current 10mA, Maximum allowance voltage 35V		
	OTHERS	*5	Parallel operation impossible , Thermal protection		
ISOLATION	INPUT-OUTPUT	Non isolated			
	INPUT, OUTPUT-FG	AC2,800V 1minute Cutoff current = 10mA, DC500V, 50MΩ min (20±15°C)			
ENVIRONMENT	OPERATING TEMP., HUMID. AND ALTITUDE	-40 to +100°C (On aluminum base plate), 20 - 95%RH (Non condensing) (Refer to "Derating") 3,000m (10,000feet) max			
	STORAGE TEMP., HUMID. AND ALTITUDE	-40 to +100°C, 20 - 95%RH (Non condensing), 9,000m (30,000feet) max			
	VIBRATION	10 - 55Hz, 49.0m/s ² (5G), 3minutes period, 60minutes each along X, Y and Z axis			
	IMPACT	196.1m/s ² (20G), 11ms, once each along X, Y and Z axis			
SAFETY	AGENCY APPROVALS	UL60950-1, C-UL, EN62368-1 Complies with DEN-AN and IEC62368-1			
	HARMONIC ATTENUATOR	Complies with IEC61000-3-2 *6			
OTHERS	CASE SIZE/WEIGHT	58.4 × 12.7 × 61mm [2.3 × 0.5 × 2.4 inches] (W × H × D) / 100g max			
	COOLING METHOD	Conduction cooling (e.g. heat radiation from the aluminum base plate to the attached heat sink)			

- *1 Refer to "Derating".
- *2 When the input voltage is more than 240V, the output voltage becomes the value proportional to the input voltage.
- *3 The value included the output setting and the line regulation, the load regulation and the temperature regulation. However, the input voltage is less than 240V.
- *4 Refer to the instruction Manual.
- *5 The thermal protection stops the power factor corrector function and the ENA signal.
- *6 Please contact us about class C.

External view

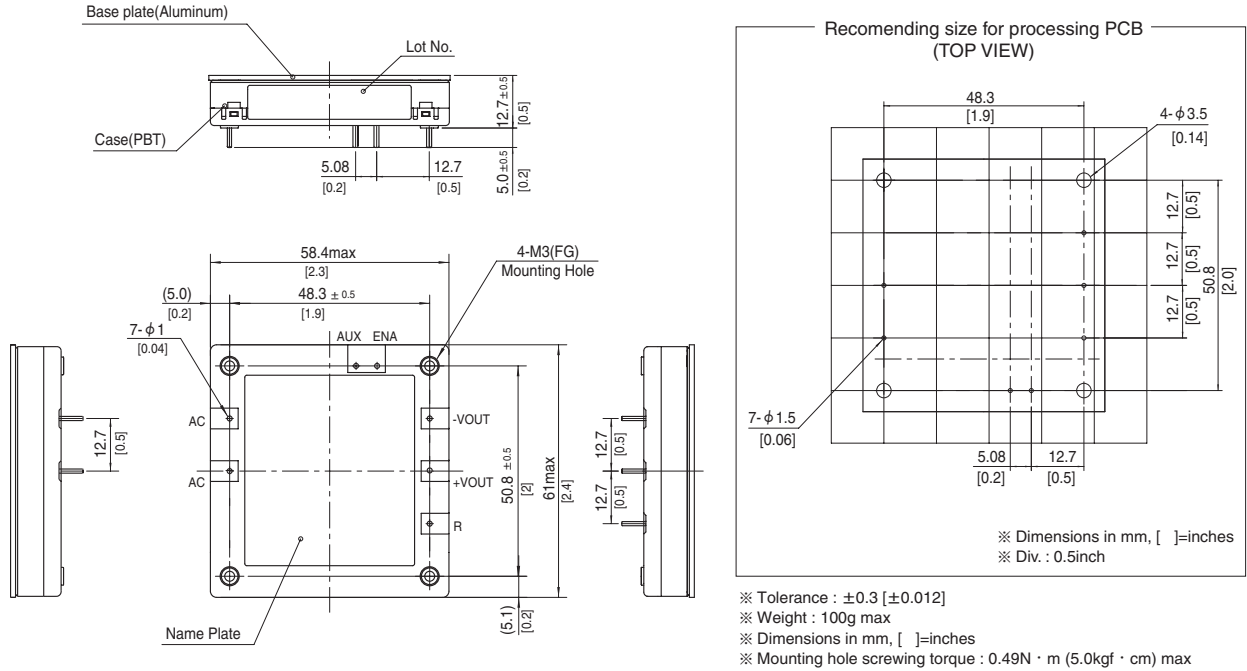

Performance data

■ STATIC CHARACTERISTICS (AC230V)

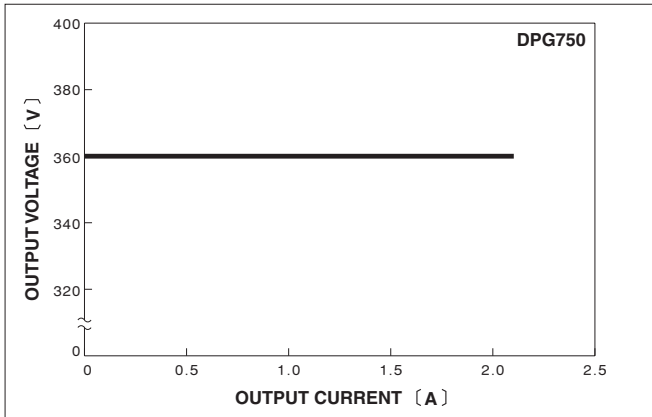

■ OUTPUT VOLTAGE FOR INPUT

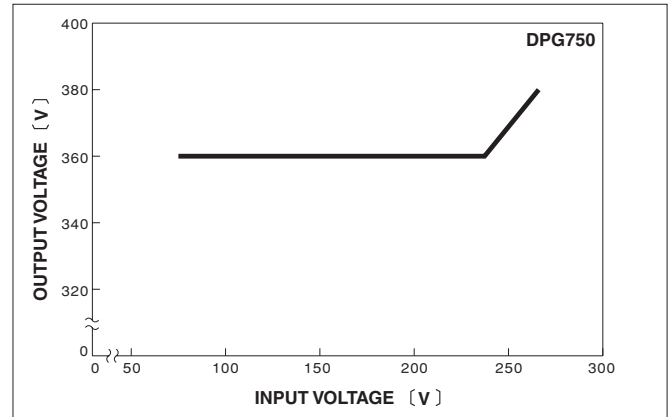

■ HARMONIC CURRENT (AC100V)

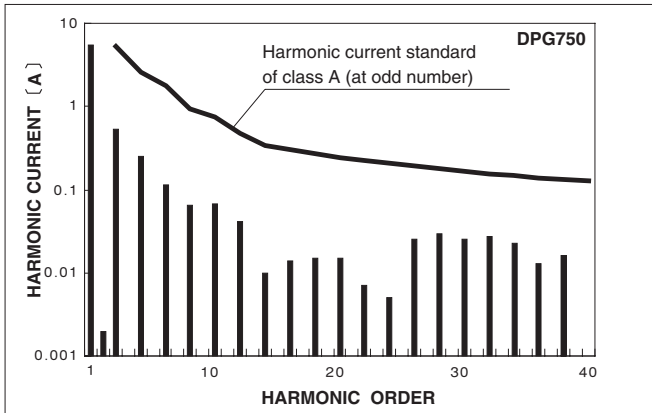

■ HARMONIC CURRENT (AC230V)

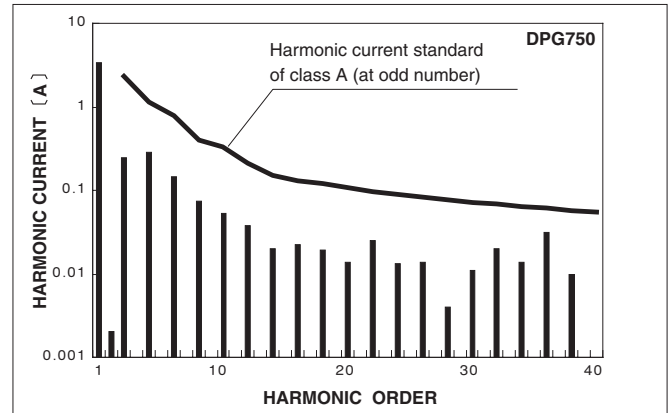

Pin Configuration

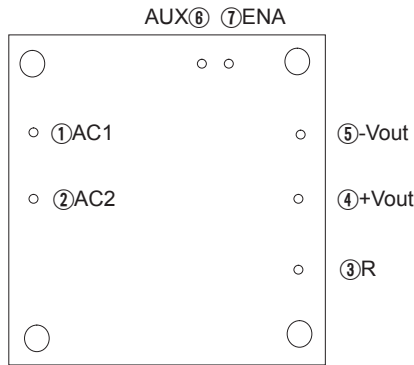

*Bottom View

No.	Pin Connection	Function
①	AC1	AC Input
②	AC2	
③	R	External resistor for inrush current protection
④	+VOUT	+DC output
⑤	-VOUT	-DC output
⑥	AUX	Auxiliary power supply for external signal
⑦	ENA	Enable signal

Implementation • Mounting Method

Mounting method

- The unit can be mounted in any direction. When two or more power supplies are used side by side, position them with proper intervals to allow enough air ventilation. Aluminum base plate temperature around each power supply should not exceed the temperature range shown in “Derating”.
- Avoid placing the AC input line pattern layout underneath the unit, it will increase the line conducted noise. Make sure to leave an ample distance between the line pattern layout and the unit. Also avoid placing the DC output line pattern of DC-DC converter underneath the unit because it may increase the output noise. Lay out the pattern away from the unit.
- High-frequency noise radiates directly from the unit to the atmosphere. Therefore, design the shield pattern on the printed circuit board and connect its one to FG. The shield pattern prevents noise radiation.

Stress onto the pins

- When too much stress is applied to the pins may damage internal connections. Avoid applying stress in excess of that shown in right figure.
- The pins are soldered onto the internal PCB. Therefore, Do not bend or pull the leads with excessive force.
- Mounting hole diameter of PCB should be 3.5mm to reduce the stress to the pins.
- Fix the unit on PCB (fixing fittings) by screws to reduce the stress to the pins. Be sure to mount the unit first, then solder the unit.

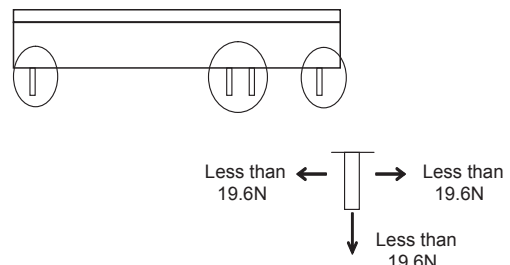

Soldering

- Flow soldering : 260°C less than 15 seconds.
- Soldering iron : 450°C less than 5 seconds.

Derating

Derating curve for input voltage

Below shows rated output for each input voltage section. Maximum output should be within this range.

● DPG500

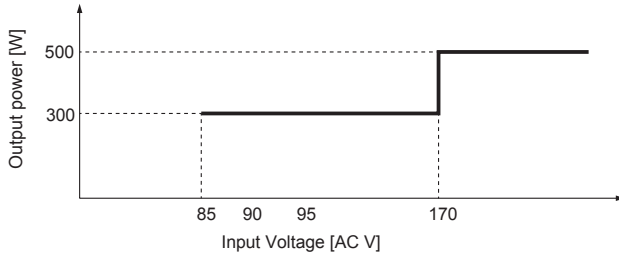

● DPG750

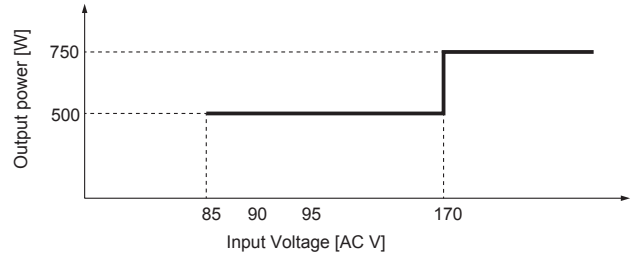

Output voltage derating curve

Use with the conduction cooling (e.g. heat radiation by conduction from the aluminum base plate to the attached heat sink). Below shows the derating curve based on the aluminum base plate temperature. In the hatched area, the specification of Ripple and Ripple Noise is different from other areas.

Please measure the temperature on the aluminum base plate edge side when you cannot measure the temperature of the center part of the aluminum base plate. In this case, please take 5deg temperature margin from the derating characteristic of Below.

It is necessary to note the thermal fatigue life by power cycle. Please reduce the temperature fluctuation range as much as possible when the up and down of the temperature are frequently generated. Contact us for more information on cooling methods.

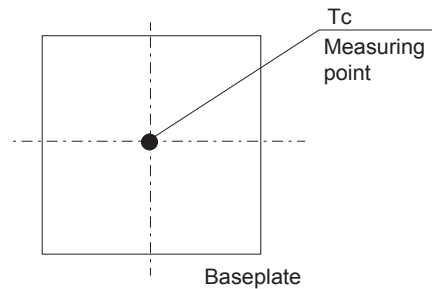
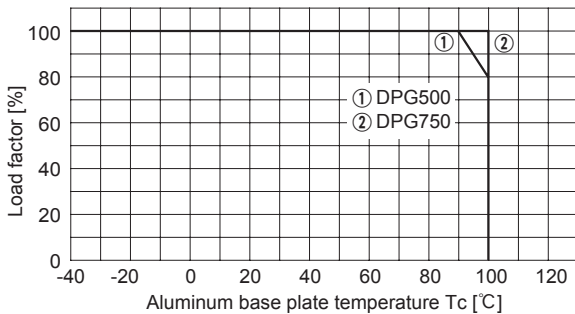

DPG

Instruction Manual

It is necessary to read the "Instruction Manual" and "Before using our product" before you use our product.

Instruction Manual <https://www.cosel.co.jp/redirect/catalog/en/DPG/>
 Before using our product <https://en.cosel.co.jp/technical/caution/index.html>



Basic Characteristics Data

Model	Circuit method	Switching frequency [kHz]	Inrush current protection	PCB/Pattern			Series/Parallel operation availability	
				Material	Single sided	Double sided	Series operation	Parallel operation
DPG500	Active filter	130	SCR	Aluminum	Yes		No	No
DPG750	Active filter	130	SCR	Aluminum	Yes		No	No



DPF-series

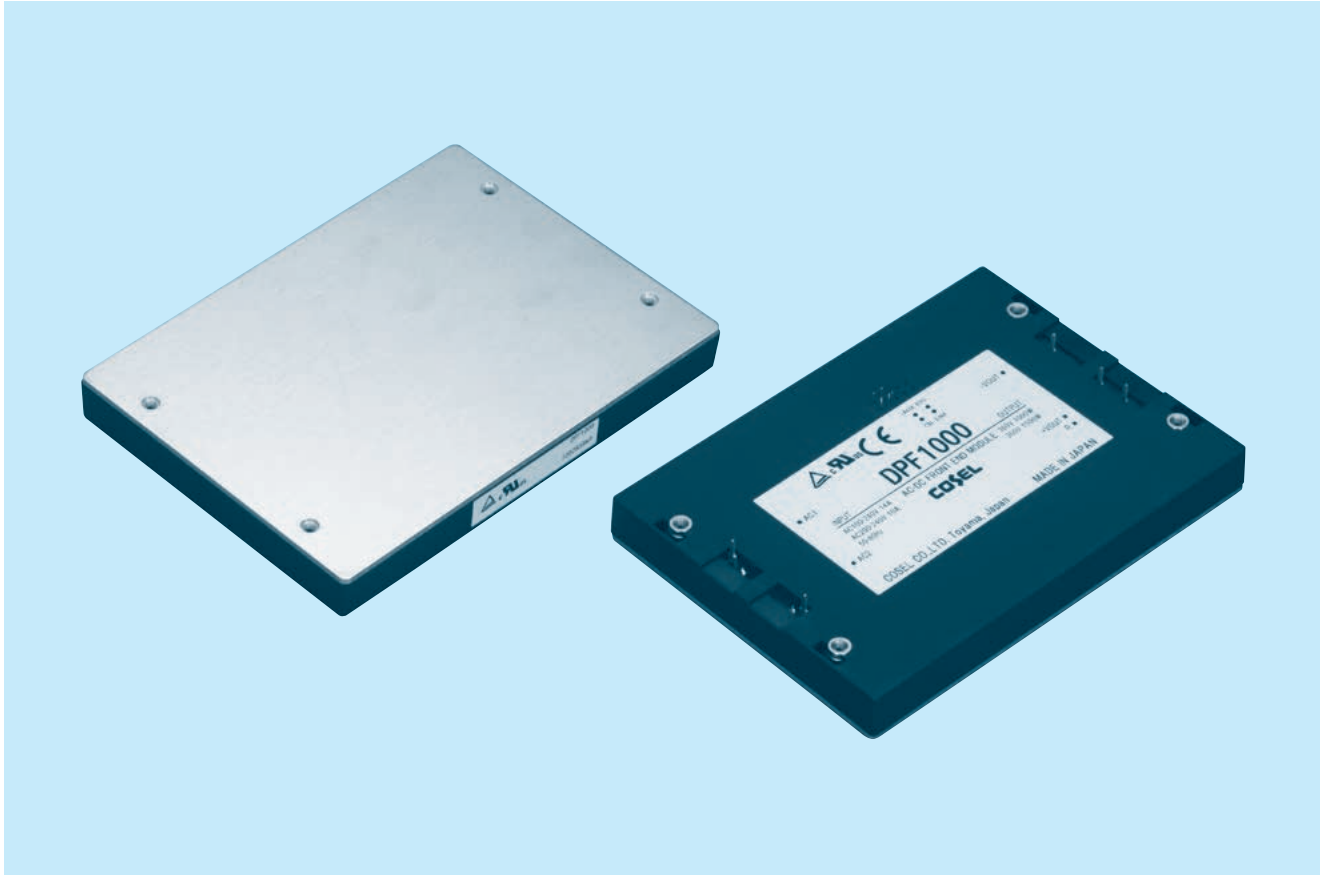

■ Power factor correction module

■ Feature

- Harmonic attenuator (Complies with IEC61000-3-2)
- High efficiency 90% (AC100V), 95% (AC200V)
- Universal input voltage (AC85 - 264V)
- Built-in inrush current protection
- Parallel operation is possible (Built-in current balancing function)
- Built-in overvoltage and thermal protection circuits
- Inverter operation monitoring (IOG)
- Enable signal (ENA)
- Auxiliary power supply for external signal (AUX)
- Ideal for distributed power systems

■ 5-year warranty

■ CE marking

- Low Voltage Directive
- RoHS Directive

■ UKCA marking

- Electrical Equipment Safety Regulations
- RoHS Regulations

■ Safety agency approvals

- UL, C-UL recognized, TÜV approved

DPF

DPF1000

DPF 1000

① ②

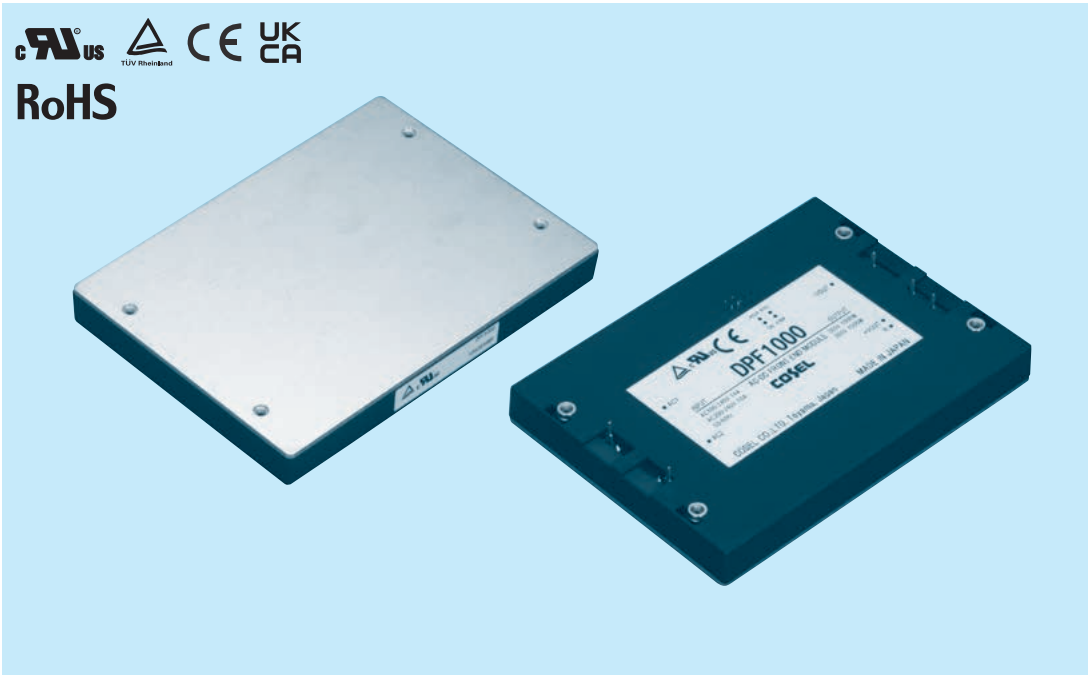

① Series name
② Output wattage

MODEL	DPF1000	
AC INPUT[V]	AC85 - 264	AC170 - 264
MAX OUTPUT WATTAGE[W]	1,000	1,500
DC OUTPUT VOLTAGE[V]	DC360	

SPECIFICATIONS

	MODEL	DPF1000
INPUT	VOLTAGE[V]	AC85 - 264 1 φ
	POWER FACTOR CORRECTION RANGE[V]	AC85 - 255 1 φ
	CURRENT[A]	11.5typ (ACIN 100V)
	FREQUENCY[Hz]	50/60 (47 - 63)
	INRUSH CURRENT[A]	Limited by external resistance
	EFFICIENCY[%]	90typ (ACIN 100V)
	POWER FACTOR	0.98typ (ACIN 100V)
	LEAKAGE CURRENT[ma]	0.75max (60Hz, According to IEC62368-1 and DEN-AN)
OUTPUT	WATTAGE[W] *1	1,000
	VOLTAGE[V] *2	DC360
	VOLTAGE ACCURACY[V] *3	±20
PROTECTION CIRCUIT AND OTHERS	OVERVOLTAGE PROTECTION[V]	DC400 - 450 The power factor corrector function stops
	IOG	Inverter operation monitoring, Open-collector output, Maximum sink current 10mA, Maximum allowance voltage 35V
	ENA	Enable signal, Open-collector output, Maximum sink current 10mA, Maximum allowance voltage 35V
	AUX	Auxiliary power supply for external signal, Output voltage:6.5 - 8.5V maximum, Output current:10mA
ISOLATION	OTHERS	Parallel operation possible (Current balancing function), N+1 redundant operation possible, Thermal protection
	INPUT-OUTPUT	Non isolated
ENVIRONMENT	INPUT, OUTPUT-FG	AC3,000V 1minute Cutoff current = 10mA, DC500V, 50MΩmin (20±15°C)
	OPERATING TEMP.,HUMID.AND ALTITUDE *4	-20 to +85°C (Aluminum base plate), 20 - 95%RH (Non condensing) (Refer to "Derating"), 3,000m (10,000feet) max
	STORAGE TEMP.,HUMID.AND ALTITUDE	-40 to +85°C, 20 - 95%RH (Non condensing), 9,000m (30,000feet) max
	VIBRATION	10 - 55Hz, 49.0m/s ² (5G), 3minutes period, 60minutes each along X, Y and Z axis
SAFETY	IMPACT	196.1m/s ² (20G), 11ms, once each X, Y and Z axis
	AGENCY APPROVALS	UL60950-1, C-UL, EN62368-1 Complies with DEN-AN and IEC62368-1
OTHERS	HARMONIC ATTENUATOR	Complies with IEC61000-3-2 *5
	CASE SIZE/WEIGHT	118.6 × 12.7 × 85mm [4.67 × 0.5 × 3.35 inches] (W × H × D) /200g max
	COOLING METHOD	Conduction cooling (e.g. heat radiation from the aluminum base plate to the attached heat sink)

*1 Refer to "Derating".

*2 When the input voltage is more than 255V, the power factor corrector function stops, and the output voltage becomes rectified AC input voltage.

*3 The value included the output setting and the line regulation, the load regulation and the temperature regulation.
However, the input voltage is in the power factor correction range.

*4 Please consult us in regard to use from -40°C.

*5 Please contact us about class C.

* External components are required. Refer to standard connection method.

External view

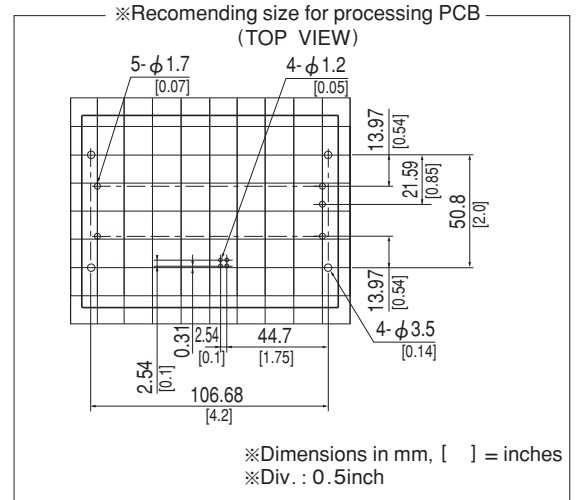
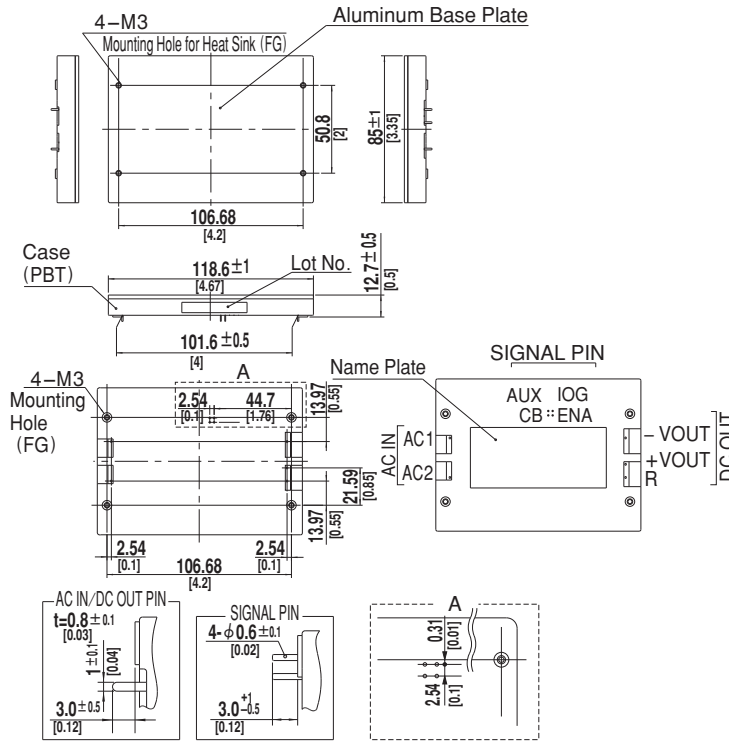

- ※Weight: 200g max
- ※Tolerance: ± 0.3 [± 0.012]
- ※Dimensions in mm, [] = inches
- ※Base Plate: Aluminum
- ※Mounting torque
- Mounting hole screwing torque 0.49N·m (5.0kgf·cm) max

Performance data

■ STATIC CHARACTERISTICS

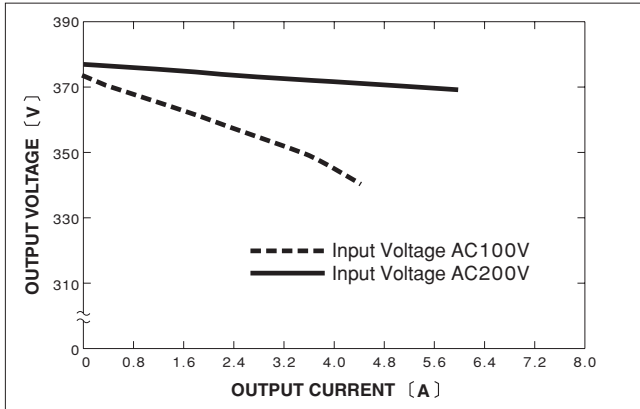

■ OUTPUT VOLTAGE FOR INPUT

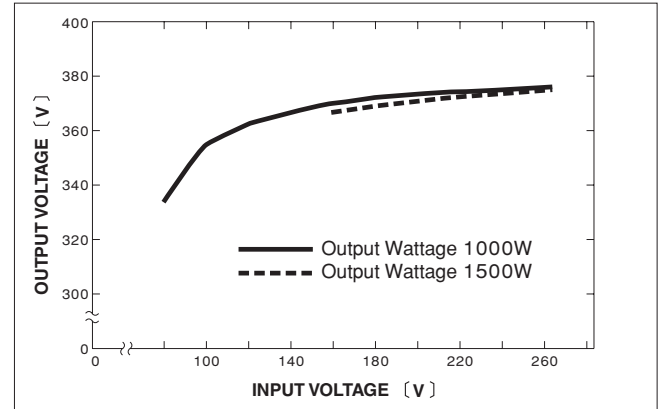

■ HARMONIC CURRENT (AC100V)

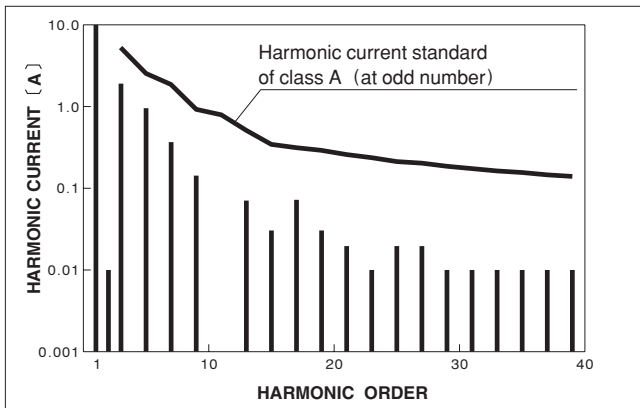

■ HARMONIC CURRENT (AC230V)

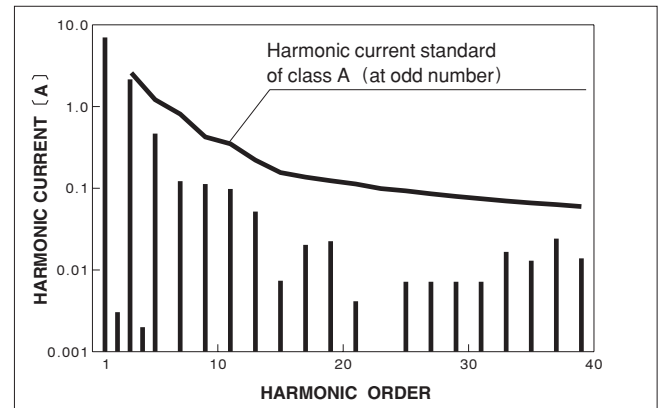

DPF

Pin Configuration

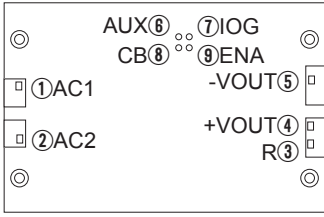

★ Bottom View

No.	Pin connection	Function
①	AC1	AC Input
②	AC2	
③	R	External resistor for inrush current protection
④	+VOUT	+DC Output
⑤	-VOUT	-DC Output
⑥	AUX	Auxiliary power supply for external signal
⑦	IOG	Inverter operation monitor
⑧	CB	Current balance
⑨	ENA	Enable signal

Implementation • Mounting Method

Installation method

- The unit can be mounted in any direction. When two or more power supplies are used side by side, position them with proper intervals to allow enough air ventilation. Aluminum base plate temperature around each power supply should not exceed the temperature range shown in derating curve.
- Avoid placing the AC input line pattern lay out underneath the unit, it will increase the line conducted noise. Make sure to leave an ample distance between the line pattern lay out and the unit. Also avoid placing the DC output line pattern of DC-DC converter underneath the unit because it may increase the output noise. Lay out the pattern away from the unit.
- High-frequency noise radiates directly from the unit to the atmosphere. Therefore, design the shield pattern on the printed circuit board and connect its one to FG. The shield pattern prevents noise radiation.

Stress onto the pins

- When too much stress is applied to the pins of the power supply, the internal connection may be weakened. As shown in right figure avoid applying stress of more than 29.4N(3kgf) on the input pins/output pins(A part) and more than 9.8N(1kgf) to the signal pins(B-part).
- The pins are soldered on PCB internally, therefore, do not pull or bend them with abnormal forces.
- Fix the unit on PCB(fixing fittings) to reduce the stress onto the pins.

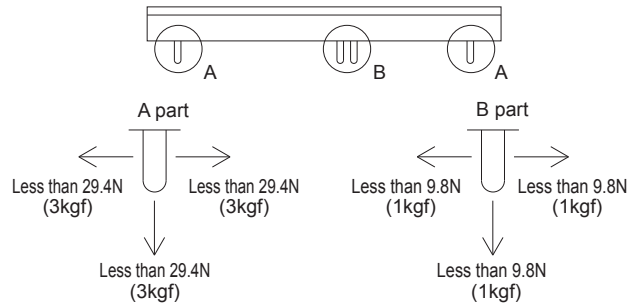

DPF

Soldering

- Flow soldering : 260°C less than 15 seconds.
- Soldering iron
 - AC IN/DC OUT/R pins : 450°C less than 5 seconds.
 - Signal pins : 350°C less than 3 seconds(less than 20W)

Derating

Derating curve for input voltage

Below shows rated output for each input voltage section. Maximum output should be within this range.

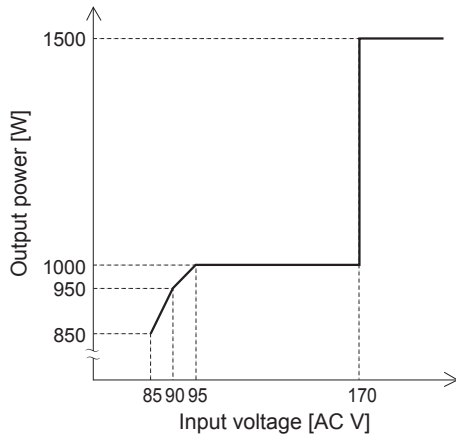

Output voltage derating curve

Use with the conduction cooling (e.g. heat radiation by conduction from the aluminum base plate to the attached heat sink). Below shows the derating curve based on the aluminum base plate temperature. In the hatched area, the specification of Ripple and Ripple Noise is different from other areas.

It is necessary to note thermal fatigue life by power cycle. Please reduce the temperature fluctuation range as much as possible when the up and down of temperature are frequently generated. Contact for more information on cooling methods.

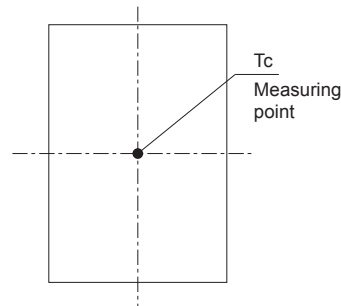
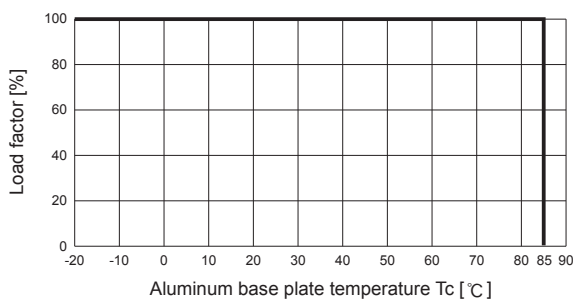

DPF

Instruction Manual

It is necessary to read the "Instruction Manual" and "Before using our product" before you use our product.

Instruction Manual <https://www.cosel.co.jp/redirect/catalog/en/DPF/>
 Before using our product <https://en.cosel.co.jp/technical/caution/index.html>

DPF



NOTICE



Basic Characteristics Data

Model	Circuit method	Switching frequency [kHz]	Input current [A]	Rated input fuse	Inrush current protection	PCB/Pattern			Series/Parallel operation availability	
						Material	Single sided	Double sided	Series operation	Parallel operation
DPF1000	Active filter	130	11.5 *1	-	SCR	Aluminum	Yes		No	Yes
			8.5 *2							

*1 The value of input current is at ACIN 100V and 1000W load.
 *2 The value of input current is at ACIN 200V and 1500W load.



AME-series

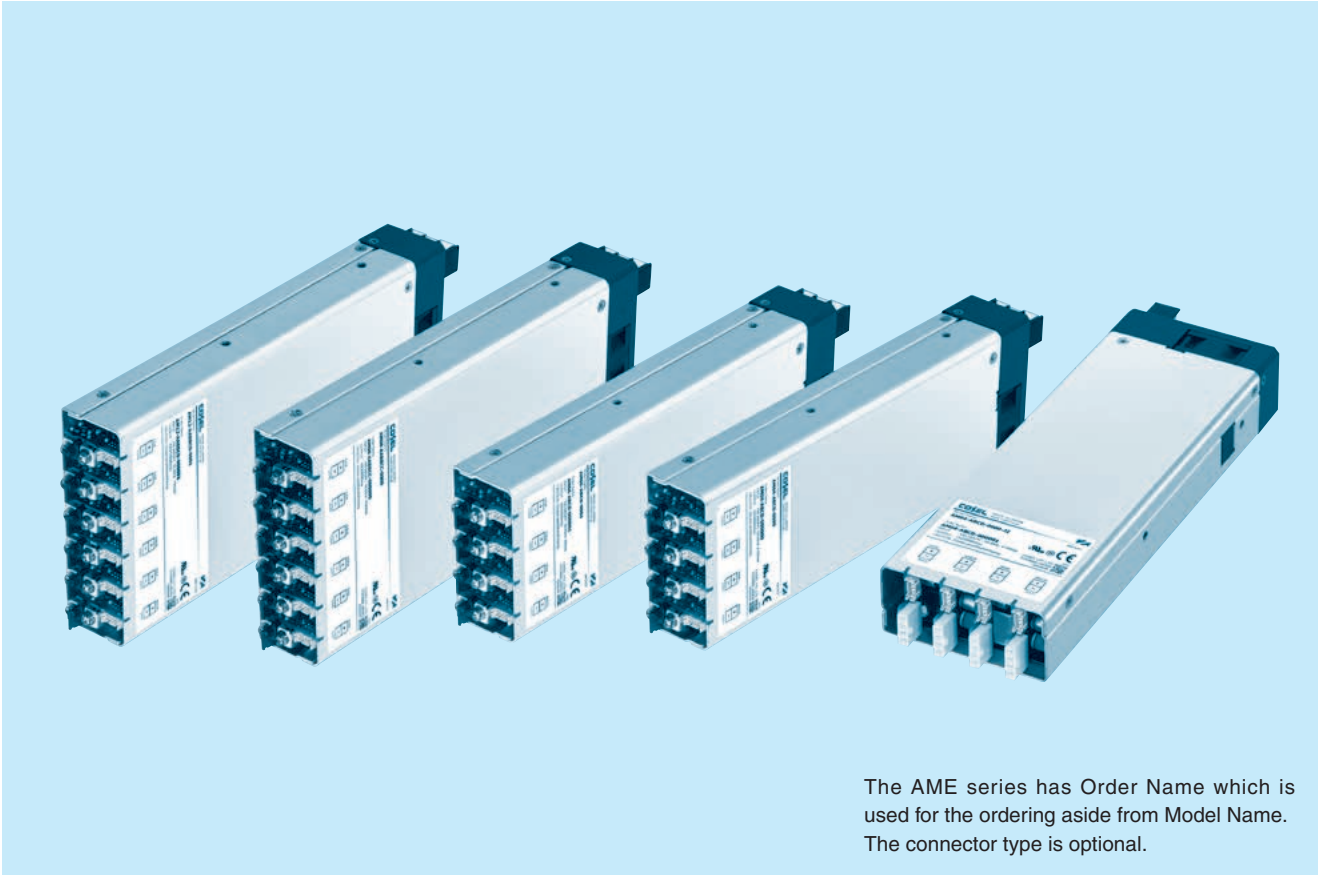

The AME series has Order Name which is used for the ordering aside from Model Name. The connector type is optional.

Feature

- Flexible modular system architecture provides various output configuration
- Low profile (41mm, 1.61inch=meet to 1U height)
- Universal input (AC85-264V)
- For medical electric equipment (ANSI/AAMI ES60601-1, EN60601-1 3rd, IEC60601-1-2 4th Ed.)
- With AUX output 5V 1A
- Global inhibit, Remote ON/OFF control
- Connector type output terminal (Option)
- Monitoring function and some parameter changes by communication are available (Option)

Safety agency approvals

- UL62368-1, ANSI/AAMI ES60601-1
- C-UL (CAN/CSA62368-1), C-UL (CAN/CSA60601-1)
- EN62368-1, EN60601-1 3rd

5-year warranty (refer to Instruction Manual)

CE marking

- Low Voltage Directive
- RoHS Directive

UKCA marking

- Electrical Equipment Safety Regulations
- RoHS Regulations

EMI

- Complies with FCC-B, CISPR11-B, CISPR32-B, EN55011-B, EN55032-B, VCCI-B

EMS Compliance : EN61204-3, EN61000-6-2

IEC60601-1-2 (2014), EN60601-1-2 (2015)

- EN61000-4-2
- EN61000-4-3
- EN61000-4-4
- EN61000-4-5
- EN61000-4-6
- EN61000-4-8
- EN61000-4-11

AME

AME series

AM - - -

① ② ③ ④ ⑤ ⑥ ⑦ ⑧ ⑨ ⑩ ⑪



RoHS

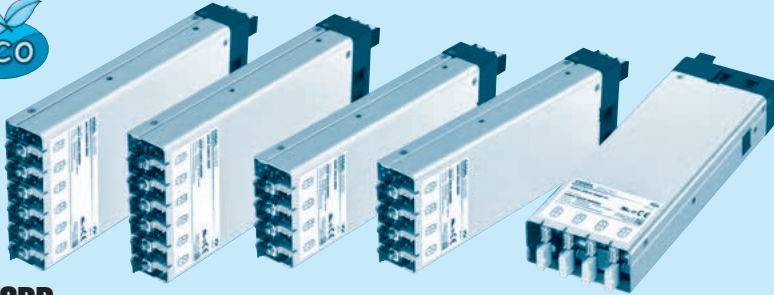

2MOPP



Output connector type (option: -J2)

The AME series has Order Name which is used for the ordering aside from Model Name.

Example recommended EMI/EMC filter
 AME400F NAC-06-472
 AME600F NAC-10-472
 AME800F NAC-16-472
 AME1200F NAC-20-472



High voltage pulse noise type : NAP series
 Low leakage current type : NAM series
 * A higher current rating EMI/EMC filter may be recommended in view of the other devices that could be connected in parallel with the power supply.

- ① Abbreviation for series name of AME series
 - ② Abbreviation for output power of AME series
 04 : AME400F
 06 : AME600F
 08 : AME800F
 12 : AME1200F
 - ③ Slot 6 Output module
 - ④ Slot 5 Output module
 - ⑤ Slot 4 Output module
 - ⑥ Slot 3 Output module
 - ⑦ Slot 2 Output module
 - ⑧ Slot 1 Output module
 - ⑨ Parallel code
 - ⑩ Series code
 - ⑪ Option *6
- A : 12V/0.1A AUX instead of 5V1A
 R : Reversed logic remote on/off
 J2 : Output connector type
 J3 : CN1/CN2/CN3 Molex connectors
 C : with Coating
 F3 : Reverse air exhaust type
 G : Low leakage current
 I3 : with Extended-UART interface
 I : with PMBus interface
 Refer to instruction manual 6.1

*Make sure necessary tests will be carried out on your end equipment with the power supply installed in accordance with any required EMC/EMI regulations.

SPECIFICATIONS

	MODEL	AME400F	AME600F	AME800F	AME1200F	
INPUT	VOLTAGE [VAC]	85-264 1 φ				
	CURRENT [A]	ACIN 100V	3.0typ	5.0typ	7.0typ	12typ
		ACIN 230V	2.0typ	3.2typ	4.0typ	6.4typ
	FREQUENCY [Hz]	50/60 (45 - 66)				
	EFFICIENCY [%]	ACIN 100V	85typ	87typ	87typ	88typ
		ACIN 230V	89typ	91typ	90typ	91typ
	POWER FACTOR	ACIN 100V	0.98typ	0.98typ	0.98typ	0.98typ
		ACIN 230V	0.95typ	0.95typ	0.95typ	0.95typ
INRUSH CURRENT [A]	ACIN 100V	15/50typ (Po = 100%)(Primary inrush current / Secondary inrush current) (More than 3 sec. to re-start)				
	ACIN 230V	35/50typ (Po = 100%)(Primary inrush current / Secondary inrush current) (More than 3 sec. to re-start)				
LEAKAGE CURRENT [mA]	0.30max (ACIN 240V 60Hz, Io = 100%, According to IEC60601-1)					
OUTPUT	NUMBER OF SLOT	4		6		
	TOTAL OUTPUT [W]	ACIN 90-150V	250	400	600	1000
		ACIN 170-264V	400	600	800	1200
	START-UP TIME [ms]	800typ (ACIN 100V, Po = 100%)				
HOLD-UP TIME [ms]	20typ (ACIN230V, Po = 80%) / 16typ (ACIN230V, Po = 100%)					
FUNCTION	AUXILIARY POWER (AUX)	5V1A				
	GLOBAL INHIBIT (GI)	Provided				
	ALARM (PR)	Provided				
ISOLATION	INPUT - OUTPUT	4,000VAC 1minute, Cutoff current = 10mA, 500VDC 50MΩ min (At Room Temperature) 2MOPP				
	INPUT - FG	2,000VAC 1minute, Cutoff current = 10mA, 500VDC 50MΩ min (At Room Temperature) 1MOPP				
	OUTPUT - FG (Except output module V, V4, V5)	500VAC 1minute, Cutoff current = 100mA, 500VDC 50MΩ min (At Room Temperature)				
	OUTPUT - FG (Output module V, V4, V5)	1,000VAC 1minute, Cutoff current = 100mA, 500VDC 50MΩ min (At Room temperature) 1MOOP				
OUTPUT - RC, LV, AUX, PR, GI	500VAC 1minute, Cutoff current = 100mA, 500VDC 50MΩ min (At Room Temperature)					
ENVIRONMENT	OPERATING TEMP., HUMIDITY, AND ALTITUDE	-20 to +70°C, 20 - 90%RH (Non condensing)				
	STORAGE TEMP., HUMIDITY, AND ALTITUDE	-20 to +75°C, 20 - 90%RH (Non condensing)				
	VIBRATION	10 - 55Hz 19.6m/s ² (2G) 3minutes period, 60minutes each along X, Y and Z axis				
	IMPACT	196.1m/s ² (20G) 11ms, once each X, Y and Z axis				
SAFETY AND NOISE REGULATIONS	AGENCY APPROVALS	UL62368-1, C-UL (CAN/CSA-C22.2 No.62368-1), EN62368-1, ANSI/AAMI ES60601-1, C-UL (CAN/CSA-C22.2 No.60601-1), EN60601-1 3rd Complies with IEC60601-1-2 4th Ed.				
	CONDUCTED NOISE	Complies with FCC-B, VCCI-B, CISPR11-B, CISPR32-B, EN55011-B, EN55032-B				
	HARMONIC ATTENUATOR	Complies with IEC61000-3-2 (classA)				
OTHERS	CASE SIZE	89 X 41 X 257mm (W X H X D) [3.50 X 1.61 X 10.12 inches]		127 X 41 X 257mm (W X H X D) [5.00 X 1.61 X 10.12 inches]		
	WEIGHT [kg]	1.2max		1.8max		
	COOLING METHOD	Forced cooling (internal fan)				

*1 The current of input surge to a built-in EMI/EMS Filter(0.2ms or less) is excluded.
 *2 Refer to "Derating".
 *3 Each output module,V1-V2 (only module R), RC, LV, AUX (include GI1), PR and GI (GI2,GI3) are isolated.
 *4 Case size contains neither the terminal blocks, screw nor other projections.
 *5 Please contact us about other classes.
 *6 Please contact us about safety approvals for the model with option.
 *7 At the total output power.
 The value depends on the combination of output modules or load factor.
 * The audible noise might be emitted from the power supply at the pulse load.

Output module specifications

ITEM	CODE	120W suitable single output								150W isolated dual output	
		J	A	K	B	L	C	M	D	R	
Number of slots used		1	1	1	1	1	1	1	1	1	
VOLTAGE [V]		3.3	5	7.5	12	15	24	36	48	V1:24	V2:24
MINIMUM CURRENT [A]		0	0	0	0	0	0	0	0	0	0
CURRENT [A]		15.2	12	12	8.5	8	5	3.4	2.5	3	3
PEAK CURRENT [A]	*3	-	-	-	-	-	-	-	-	-	-
LINE REGULATION [mV] max		20	20	36	48	60	96	120	192	96	96
LOAD REGULATION [mV] max		40	40	100	100	120	150	180	240	150	150
RIPPLE [mVp-p] max	0 to +50°C *1	150	150	150	150	150	250	250	400	250	250
	-20 to 0°C *1	200	200	200	200	200	300	300	450	300	300
RIPPLE NOISE [mVp-p] max	0 to +50°C *1	200	200	200	200	200	300	300	450	300	300
	-20 to 0°C *1	250	250	250	250	250	350	350	500	350	350
TEMPERATURE COEFFICIENT [mV] max	0 to +50°C	50	50	90	120	150	240	300	480	350	350
DRIFT [mV] max	*2	20	20	36	48	60	96	120	192	96	96
OUTPUT VOLTAGE SETTING [V]		3.30 to 3.40	5.00 to 5.15	7.50 to 7.80	12.00 to 12.48	15.00 to 15.60	24.00 to 24.96	36.00 to 37.44	48.00 to 49.92	23.88 to 24.96	23.88 to 24.96
OUTPUT VOLTAGE ADJUSTMENT RANGE [V]		2.64 to 3.96	4.0 to 6.0	6.0 to 9.0	9.6 to 14.4	12.0 to 18.0	19.2 to 28.8	28.8 to 43.2	38.4 to 57.6	5.0 to 25.2	5.0 to 25.2
OVERCURRENT PROTECTION [A]		Works over 105% min of rated current. Automatic recovery. Hiccup mode.								Works over 105% min of rated current. Automatic recovery.	
OVERVOLTAGE PROTECTION [V]		4.2 to 5.6	6.5 to 7.8	9.4 to 11.6	15.0 to 18.6	18.8 to 23.2	30.0 to 37.2	45.0 to 55.8	60.0 to 74.4	30.0 to 37.2	30.0 to 37.2
FUNCTION		Remote ON/OFF (RC), Alarm (LV), DC_OK (LED: Blue)								Remote ON/OFF (RC) Alarm (LV) DC_OK (LED: Blue)	

ITEM	CODE	240W suitable single output									
		E4	E	S	F4	F	T	G4	G	U	H4
Number of slots used		1	1	1	1	1	1	1	1	1	1
VOLTAGE [V]		3.3	5	7.5	7.5	12	15	15	24	36	36
MINIMUM CURRENT [A]		0	0	0	0	0	0	0	0	0	0
CURRENT [A]		32	32	24	20	20	16	10	10	6.7	5
PEAK CURRENT [A]	*3	-	-	-	-	-	-	15	15	10	7.5
LINE REGULATION [mV] max		20	20	36	48	48	60	96	96	120	192
LOAD REGULATION [mV] max		40	40	100	100	100	120	150	150	180	240
RIPPLE [mVp-p] max	0 to +50°C *1	150	150	150	150	150	150	250	250	250	400
	-20 to 0°C *1	200	200	200	200	200	200	300	300	300	450
RIPPLE NOISE [mVp-p] max	0 to +50°C *1	200	200	200	200	200	200	300	300	300	450
	-20 to 0°C *1	250	250	250	250	250	250	350	350	350	500
TEMPERATURE COEFFICIENT [mV] max	0 to +50°C	50	50	90	120	120	150	240	240	300	480
DRIFT [mV] max	*2	20	20	36	48	48	60	96	96	120	192
OUTPUT VOLTAGE SETTING [V]		3.30 to 3.40	5.00 to 5.15	7.50 to 7.80	7.50 to 7.80	12.00 to 12.48	15.00 to 15.60	15.00 to 15.60	24.00 to 24.96	36.00 to 37.44	36.00 to 37.44
OUTPUT VOLTAGE ADJUSTMENT RANGE [V]		3.0 to 6.0	3.0 to 6.0	4.5 to 9.0	7.2 to 14.4	7.2 to 14.4	9.0 to 18.0	14.4 to 28.8	14.4 to 28.8	21.6 to 43.2	28.8 to 57.6
OVERCURRENT PROTECTION [A]		Works over 105%min of rated current or 101%min of peak current. Automatic recovery. Hiccup mode.									
OVERVOLTAGE PROTECTION [V]		Vo+1.0 to 1.5	Vo+1.0 to 1.5	Vo+1.0 to 1.7	Vo+1.2 to 2.4	Vo+1.2 to 2.4	Vo+1.5 to 3.0	Vo+2.4 to 4.8	Vo+2.4 to 4.8	Vo+3.6 to 7.2	Vo+4.8 to 7.2
FUNCTION		Remote ON/OFF (RC), Alarm (LV), Remote sensing (+S/-S), Output voltage adjustment (VTRM), Constant output current adjustment (ITRM), DC_OK (LED: Blue)									

ITEM	CODE	240W suitable single output			
		H	V4	V	V5
Number of slots used		1	1	1	1
VOLTAGE [V]		48	65	75	100
MINIMUM CURRENT [A]		0	0	0	0
CURRENT [A]		5	3	3	2.25
PEAK CURRENT [A]	*3	7.5	-	-	-
LINE REGULATION [mV] max		192	300	300	300
LOAD REGULATION [mV] max		240	350	350	350
RIPPLE [mVp-p] max	0 to +50°C *1	400	500	500	500
	-20 to 0°C *1	450	550	550	550
RIPPLE NOISE [mVp-p] max	0 to +50°C *1	450	550	550	550
	-20 to 0°C *1	500	600	600	600
TEMPERATURE COEFFICIENT [mV] max	0 to +50°C	480	750	750	750
DRIFT [mV] max	*2	192	300	300	300
OUTPUT VOLTAGE SETTING [V]		48.00 to 49.92	65.00 to 67.60	75.00 to 78.00	100.0 to 104.0
OUTPUT VOLTAGE ADJUSTMENT RANGE [V]		28.8 to 57.6	57.6 to 105.0	57.6 to 105.0	57.6 to 105.0
OVERCURRENT PROTECTION [A]		Works over 105%min of rated current or 101%min of peak current. Automatic recovery. Hiccup mode.			
OVERVOLTAGE PROTECTION [V]		Vo+4.8 to 7.2	Vo+7.5 to 11.3	Vo+7.5 to 11.3	Vo+7.5 to 11.3
FUNCTION		Remote ON/OFF (RC), Alarm (LV), Remote sensing (+S/-S), Output voltage adjustment (VTRM), Constant output current adjustment (ITRM), DC_OK (LED: Blue)			

*1 Measured by 20MHz oscilloscope or Ripple-Noise meter (equivalent to KEISOKUGIKEN: RM104).

*2 Drift is the change in DC output for an eight hours period after a half-hour warm-up at 25°C.

*3 The peak current should be under the following conditions.

Duration: 5s or less
Duty: 35% or less
Average current: Rated current or less

Block diagram

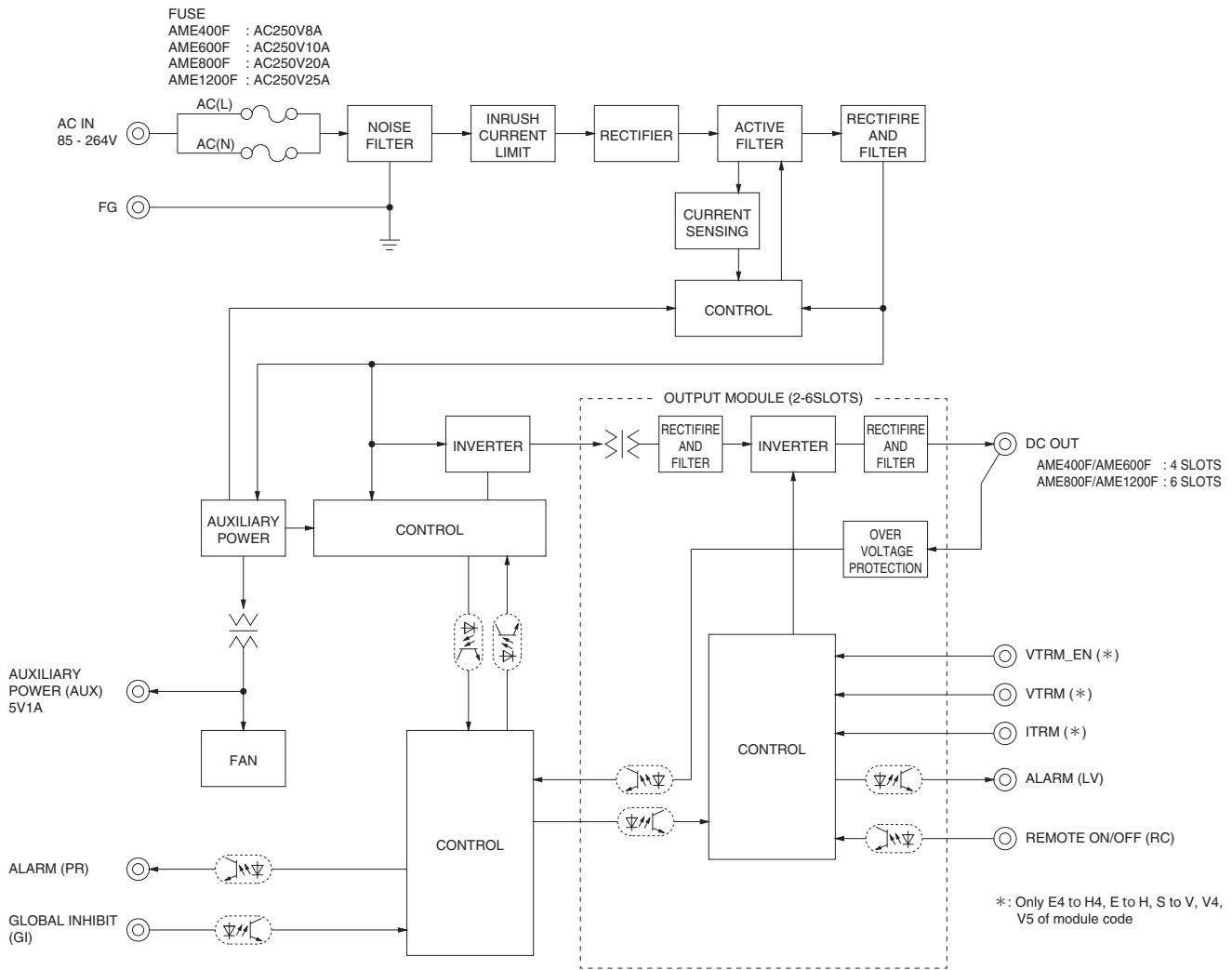

AME400F/AME600F external view

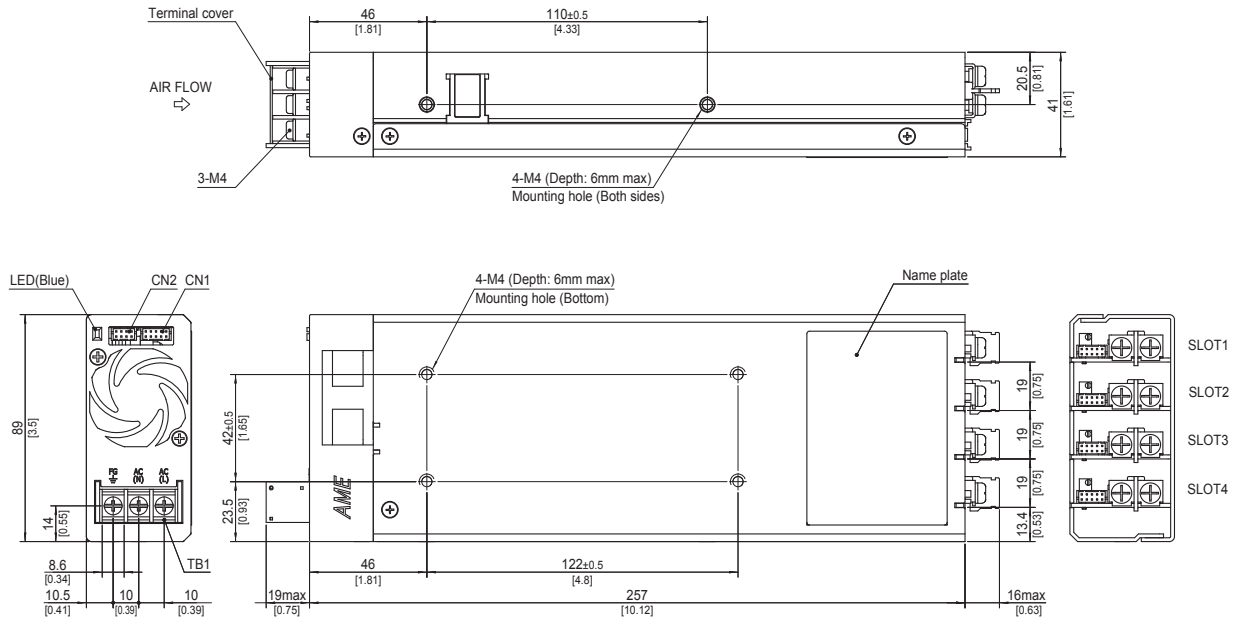

- ※ Tolerance : ±1 [±0.04]
- ※ Weight : 1.2kg max
- ※ PCB Material/thickness : FR-4 / 1.6mm [0.06]
- ※ Chassis material : Aluminum
- ※ Fan cover Material : PBT
- ※ Dimensions in mm, [] = inches
- ※ Mounting torque M4 : 1.2N · m max
- ※ Input and output terminal screw tightening torque M4 : 1.6N · m max
- ※ Please connect safety ground to Mounting Hole or FG terminal on the unit.

AME800F/AME1200F external view

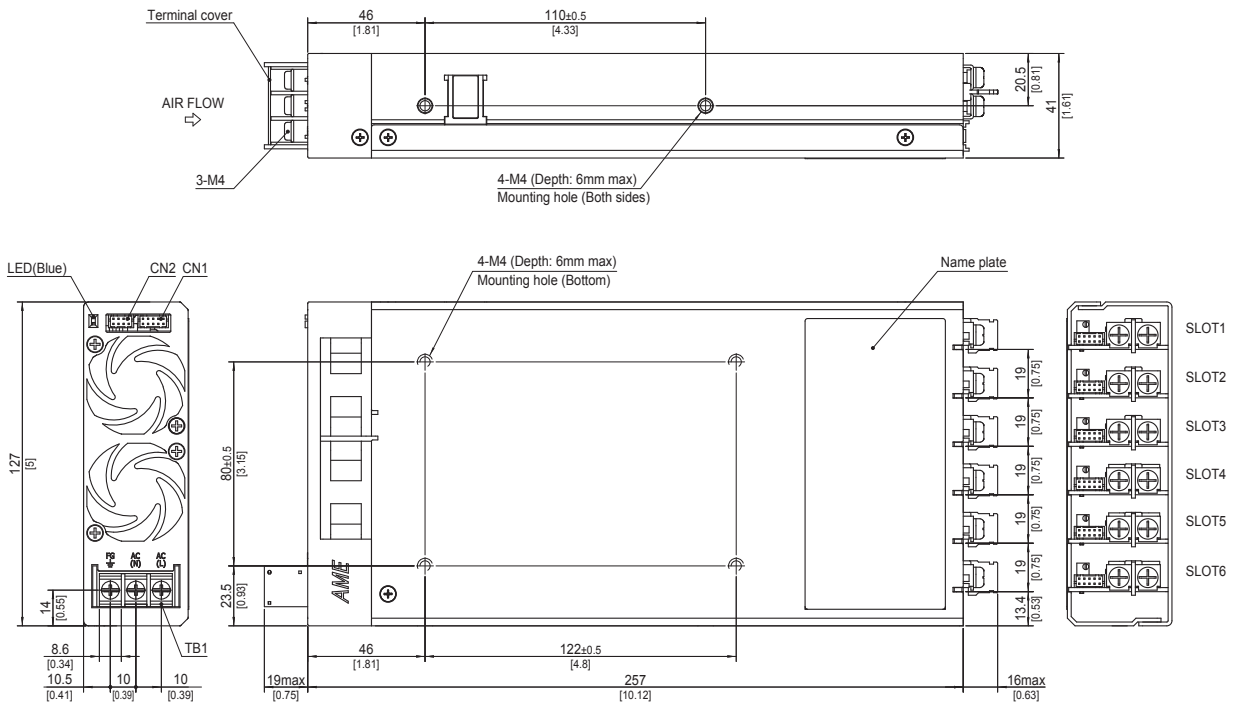

- ※ Tolerance : ±1 [±0.04]
- ※ Weight : 1.8kg max
- ※ PCB Material/thickness : FR-4 / 1.6mm [0.06]
- ※ Chassis material : Aluminum
- ※ Fan cover Material : PBT
- ※ Dimensions in mm, [] = inches
- ※ Mounting torque M4 : 1.2N · m max
- ※ Input and output terminal screw tightening torque M4 : 1.6N · m max
- ※ Please connect safety ground to Mounting Hole or FG terminal on the unit.

Output module

1. Output side view

AME400F/AME600F Output side view

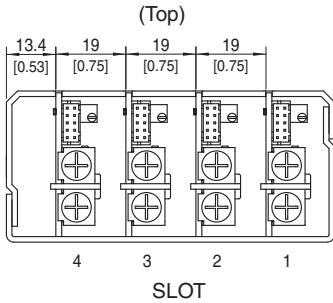

AME800F/AME1200F Output side view

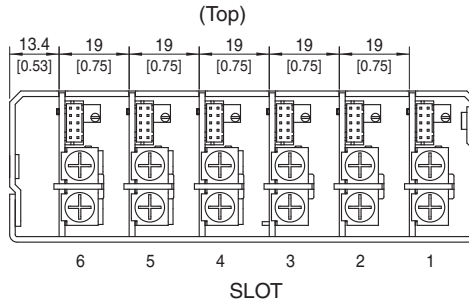

※Tolerance : ± 1 [± 0.04]
 ※Dimensions in mm, []=inches

2. Output module side view

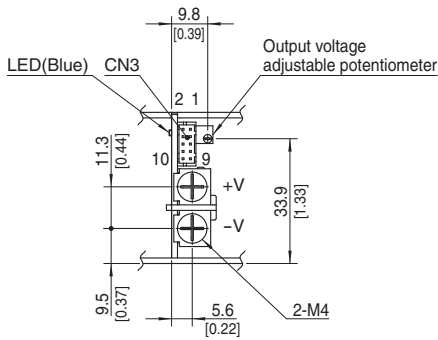

Module : A-H,J-M,S-V,E4-H4,V4,V5 ※Tolerance : ± 1 [± 0.04]
 ※Dimensions in mm, []=inches

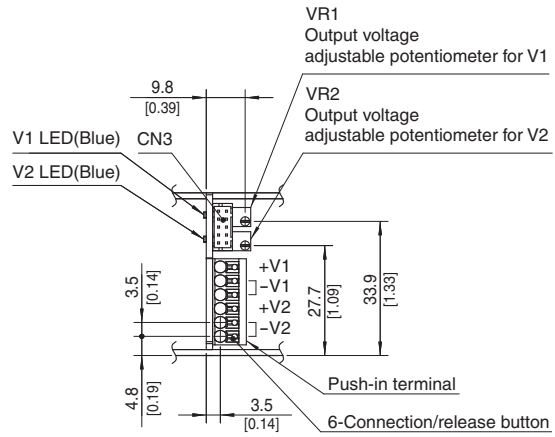

Module : R ※Tolerance : ± 1 [± 0.04]
 ※Dimensions in mm, []=inches

Terminal Blocks and connector pin assign

● AME400F/AME600F

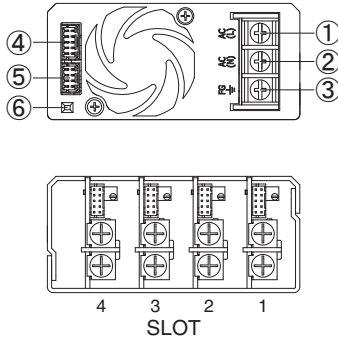

● AME800F/AME1200F

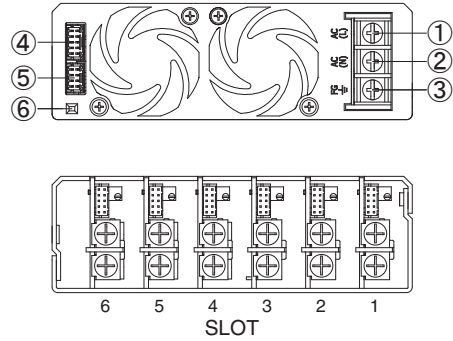

- ①AC (L) } Input Terminals 85 - 264VAC 1 φ 45 - 66Hz
- ②AC (N) } (M4)
- ③Frame ground (M4)
- ④CN1 } Connector for functions
- ⑤CN2 }
- ⑥LED (DC_OK)

● Pin Configuration and Functions

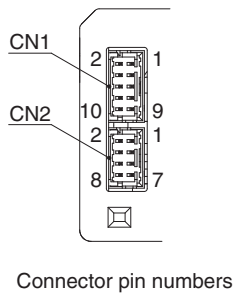

Connector pin numbers

Pin configuration and function of CN1

Pin No.	Function		Ground level
1	AUX	: Auxiliary power	AUXG
2	AUXG	: Auxiliary power ground	AUXG
3	GI1	: Global inhibit	AUXG
4	AUXG	: Auxiliary power ground	AUXG
5	GI2	: Global inhibit	GIG
6	GIG	: Global inhibit ground	GIG
7	N.C.	: No connection	-
8	N.C.	: No connection	-
9	PR	: PR Alarm	PRG
10	PRG	: PR Alarm ground	PRG

Pin configuration and function of CN2

Pin No.	Function		Ground level
1	N.C.	: No connection	-
2	N.C.	: No connection	-
3	N.C.	: No connection	-
4	N.C.	: No connection	-
5	N.C.	: No connection	-
6	N.C.	: No connection	-
7	N.C.	: No connection	-
8	N.C.	: No connection	-

* Do not connect anything to N.C. pins.

Matching connectors and terminals

Connector	Housing	Terminal	Mfr.
CN1	S10B-PHDSS	PHDR-10VS Reel : SPHD-002T-P0.5 Loose : BPHD-001T-P0.5 *1 BPHD-002T-P0.5 *1	J.S.T

*1 The manufacturer can offer only ratchet hand tool.

Terminal Blocks

● Output module

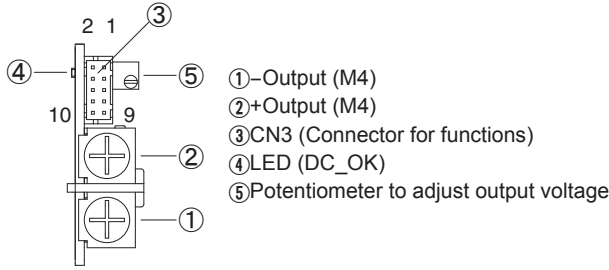

Module : A-H, J-M, S-V, E4-H4, V4, V5

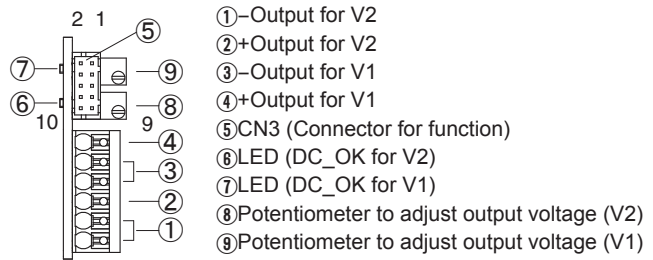

Module : R

Pin configuration and function of CN3

Pin No.	Applying module : A-D, J-M		Applying Module : E4-H4, E-H, S-V, V4, V5		Applying Module : R	
	Function	Ground level	Function	Ground level	Function	Ground level
1	RC : Remote ON/OFF	RCG	RC : Remote ON/OFF	RCG	V1_RC : Remote ON/OFF	V1_RCG
2	RCG : Remote ON/OFF ground	RCG	RCG : Remote ON/OFF ground	RCG	V1_RCG : Remote ON/OFF ground	V1_RCG
3	LV : LV Alarm	LVG	LV : LV Alarm	LVG	V1_LV : LV Alarm	V1_LVG
4	LVG : LV Alarm ground	LVG	LVG : LV Alarm ground	LVG	V1_LVG : LV Alarm ground	V1_LVG
5	N.C. : No connection	—	+S : + Remote sensing	COM	N.C. : No connection	—
6	N.C. : No connection	—	-S : - Remote sensing	COM	N.C. : No connection	—
7	N.C. : No connection	—	COM : Common ground for signal	COM	V2_RC : Remote ON/OFF	V2_RCG
8	N.C. : No connection	—	ITRM : Output current adjustment	COM	V2_RCG : Remote ON/OFF ground	V2_RCG
9	N.C. : No connection	—	VTR_EN : Enable VTRM	COM	V2_LV : LV Alarm	V2_LVG
10	N.C. : No connection	—	VTRM : Output voltage adjustment	COM	V2_LVG : LV Alarm ground	V2_LVG

* Do not connect anything to N.C. pins.

Matching connectors and terminals

Connector	Housing	Terminal	Mfr.
CN3	S10B-PHDSS	PHDR-10VS	Reel : SPHD-002T-P0.5 Loose : BPHD-001T-P0.5 *1 BPHD-002T-P0.5 *1 J.S.T

*1 The manufacturer prepares only the ratchet hand.

Assembling and Installation Method

- The unit has cooling fans. Ensure that the inlet and outlet vents are not blocked.
- If the unit is used in dusty environment, please consider installing the air filter so that cooling efficiency will not get worse. In that case, please pay sufficient attention to airflow.
- Figures to the right are the recommended installation method when the unit is mounted by screws. When the unit is installed by any other method, please take into account of its weight and secure it.
- Avoid the D installation method in the figure to the right because it will cause stress on the mounting holes.
- Maximum length from the outside of the unit of the mounting screws is 6mm so that the isolation to internal components is ensured. (Refer to right figure).
- Applicable Wire for module R

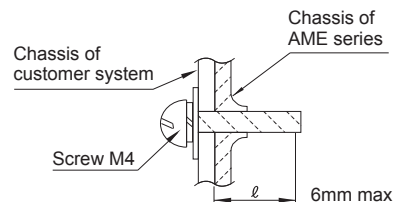
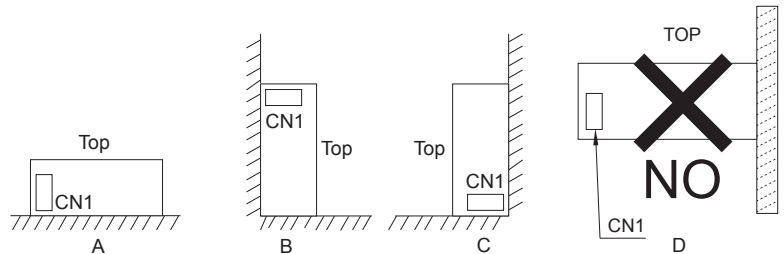

Applicable Wire

Solid wire	Diameter 0.5mm to 1.3mm (AWG.24 to AWG.16)
Standed wire	0.2mm ² to 1.5mm ² (AWG.24 to AWG.16)
Sheath strip length	8mm to 9mm

Derating

■ The AME series is comprised multiple combination output. Both the maximum output of each module and total maximum output have to be within the specs.

Derating curve for input voltage

● AME400F

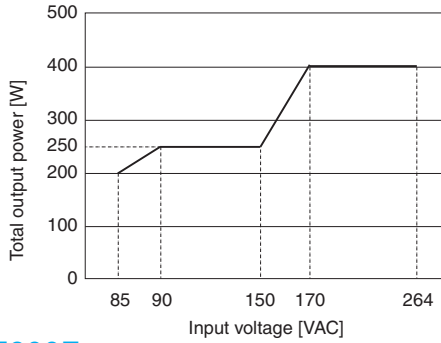

● AME600F

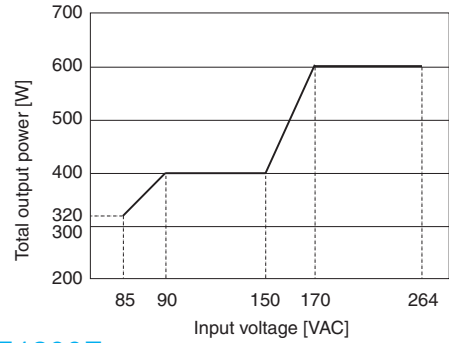

● AME800F

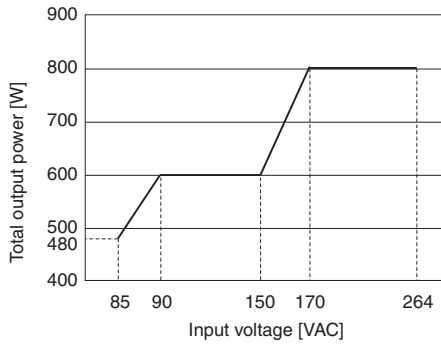

● AME1200F

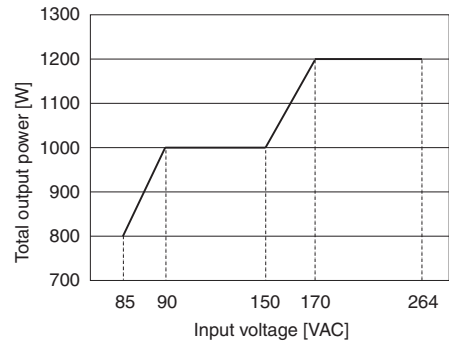

Derating curve for ambient temperature

■ Derating curve for ambient temperature

The derating curve for the ambient temperature (inlet temperature for cooling) is shown in below. The specifications of the ripple and noise in the hatching area below are different.

● AME400F

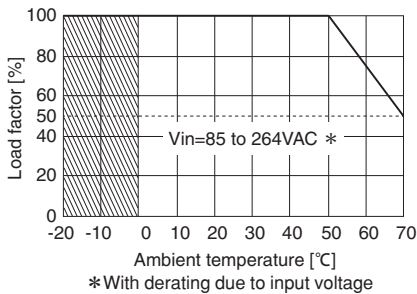

● AME600F

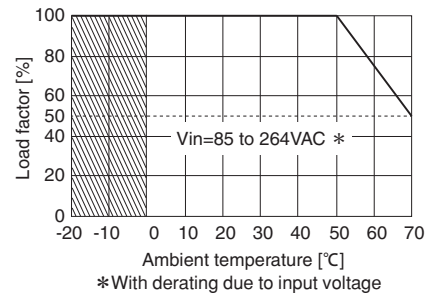

● AME800F

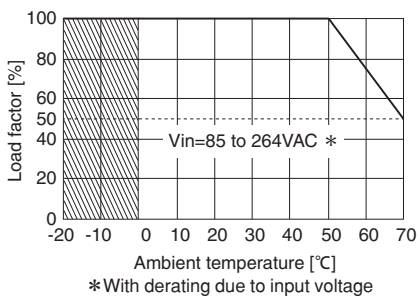

● AME1200F

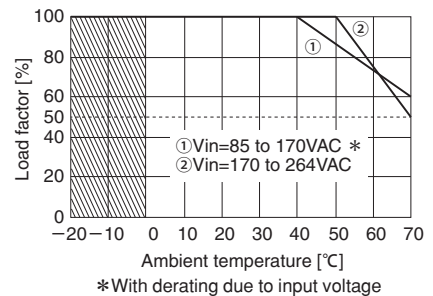

Definition of load factor

■ Definition of load factor

Load [%] = The largest value of $A_0, A_{11} - A_{62}$

$$A_0 = \frac{(\text{Sum of each module power})}{(\text{Total output power})} \times 100 = \frac{\sum_{k=1}^6 (I_{k1} \times V_{k1} + I_{k2} \times V_{k2})}{(\text{Total output power})} \times 100$$

$$A_{11}, A_{21}, A_{31}, A_{41}, A_{51}, A_{61} : AK_1 = I_{k1} / I_{OK1} \times 100$$

$$A_{12}, A_{22}, A_{32}, A_{42}, A_{52}, A_{62} : AK_2 = I_{k2} / I_{OK2} \times 100$$

I_{k1}, V_{k1}, I_{OK1} : output current, voltage, and rated current except for V2 in module R

I_{k2}, V_{k2}, I_{OK2} : output current, voltage, and rated current for V2 in module R

Total output power : Dependent upon input voltage

Suffix k means the k-th slot

※If you use the module that apply peak current at the peak current, " I_{k1} " is calculated by peak current.

When Calculating load factor of module, " I_{k1} " is calculated by average current.

A method of use peak current, Refer to 4 Peak in Instruction Manual

■ Usage example

[Example1] Method to confirm that AM04-RDBA-0000 can be used under the following conditions.

Input voltage : 100VAC Ambient temperature : 50°C

Output model : slot1 : 5V 12A slot2 : 5V 12A slot3 : 48V 1A slot4 : 24V 2A, 24V 1A

According to the "Derating curve for input voltage", total output power is 250W.

Calculating $A_{11} - A_{42}$

$$A_0 = (5 \times 12 + 12 \times 5 + 48 \times 1 + 24 \times 2 + 24 \times 1) / 250 \times 100 = 241.2 / 250 \times 100 = 96\%$$

$$A_{11} = 12 / 12 \times 100 = 100\%$$

$$A_{21} = 5 / 8.5 \times 100 = 59\%$$

$$A_{31} = 1 / 2.5 \times 100 = 40\%$$

$$A_{41} = 2 / 3 \times 100 = 67\%$$

$$A_{42} = 1 / 3 \times 100 = 34\%$$

Accordingly, because the "Derating curve for ambient temperature" indicates that up to 100% of the maximum load can be used up to 50°C and the largest value amongst $A_0, A_{11}, A_{21}, A_{31}, A_{41},$ and A_{42} is 100%, this assures that these input and output conditions are acceptable.

[Example 2] Method to confirm that AM12-RHGFFE-0000 can be used under the following conditions.

Input voltage : 200VAC Ambient temperature : 50°C

Output model : slot1 : 5V 32A slot2 : 12V 16A slot3 : 12V 10A slot4 : 24V 8A (peak 15A) slot5 : 48V 4A
slot6 : 24V 2.5A, 24V 2.5A

According to the "Derating curve for input voltage", total output power is 1200W.

Calculating $A_{11} - A_{62}$

$$A_0 = (5 \times 32 + 12 \times 16 + 12 \times 10 + 24 \times 15 + 48 \times 4 + 24 \times 2.5 + 24 \times 2.5) / 1200 \times 100 = 1144 / 1200 \times 100 = 96\%$$

$$A_{11} = 32 / 32 \times 100 = 100\%$$

$$A_{21} = 16 / 20 \times 100 = 80\%$$

$$A_{31} = 10 / 20 \times 100 = 50\%$$

$$A_{41} = 8 / 10 \times 100 = 80\%$$

$$A_{51} = 4 / 5 \times 100 = 80\%$$

$$A_{61} = 2.5 / 3 \times 100 = 84\%$$

$$A_{62} = 2.5 / 3 \times 100 = 84\%$$

Accordingly, because the "Derating curve for ambient temperature" indicates that up to 100% of the maximum load can be used up to 50°C and the largest value $A_0, A_{11}, A_{21}, A_{31}, A_{41}, A_{51}, A_{61}$ and A_{62} is 96%, this assures that these input and output conditions are acceptable.

Instruction Manual

◆ It is necessary to read the “Instruction Manual” and “Before using our product” before you use our product.

Instruction Manual <https://www.cosel.co.jp/redirect/catalog/en/AME/>
 Before using our product <https://en.cosel.co.jp/technical/caution/index.html>



Basic Characteristics Data

Model	Circuit method	Switching frequency [kHz]	Inrush current protection circuit	PCB/Pattern			Series/Parallel operation availability	
				Material	Single sided	Double sided	Series operation	Parallel operation
Input module of AME400F	Active filter	67	Relay	FR-4	-	Multilayer	N/A	N/A
	Half-bridge converter	133						
Input module of AME600F	Active filter	67	Relay	FR-4	-	Multilayer	N/A	N/A
	Half-bridge converter	133						
Input module of AME800F	Active filter	67	Relay	FR-4	-	Multilayer	N/A	N/A
	Half-bridge converter	133						
Input module of AME1200F	Active filter	67	Relay	FR-4	-	Multilayer	N/A	N/A
	Half-bridge converter	133						
Output module of A-D, J-M	Buck converter	266	-	FR-4	-	Multilayer	*1	N/A
Output module of E4-H4, E-H, S-V, V4, V5	Buck converter	266	-	FR-4	-	Multilayer	*1	*1
Output module of R	Buck converter	266	-	FR-4	-	Multilayer	*2	N/A

*1 Refer to “Series/Parallel Operation of Modular Power Supply” in the instruction manual.

*2 Series operation is possible, but series connection cannot be set by the series code.



KH-series



Feature

For DIN (35mm) rail products
Wide operating ambient temperature range
I/O terminal has 2 types, Euro Style and Barrier Blocks Style
Built in overcurrent protection, overvoltage protection circuits

- KHEA/KHNA30F~90F
Low power consumption at no load
Complies with SEMI F-47 (Derating is required)
- KHEA/KHNA120F~480F
Built in remote ON/OFF
Built in signal output for confirming output voltage
Complies with SEMI F-47

Safety agency approvals

EN62368-1, UL508, ATEX (All models)
UL60950-1, C-UL (CSA60950-1)
(KHEA/KHNA30F~120F, KHEA/KHNA480F)
UL62368-1, C-UL (CSA62368-1) (KHEA/KHNA240)
UL121201 (KHEA/KHNA30F~240F)
ANSI/ISA12.12.01 (KHEA/KHNA480F)
Complies with DEN-AN

5-year warranty (refer to Instruction Manual)

CE marking

Low Voltage Directive
RoHS Directive

UKCA marking

Electrical Equipment Safety Regulations
RoHS Regulations

EMI

Complies with FCC-B, CISPR22-B, EN55011-B, EN55022-B, VCCI-B

EMS Compliance : EN61204-3, EN61000-6-2

EN61000-4-2
EN61000-4-3
EN61000-4-4
EN61000-4-5
EN61000-4-6
EN61000-4-8
EN61000-4-11

KHEA/KHNA30F

KH A 30 F - -

① ② ③ ④ ⑤ ⑥



Example recommended EMI/EMC filter
NAC-04-472-D



High voltage pulse noise type : NAP series
Low leakage current type : NAM series
* A higher current rating EMI/EMC filter may be recommended in view of the other devices that could be connected in parallel with the power supply.

- ① Series name
KHE : Euro style I/O terminals
KHN : Barrier blocks style I/O terminals
- ② Single output
- ③ Output wattage
- ④ Universal input
- ⑤ Output voltage
- ⑥ Option
C : with Coating

*Make sure necessary tests will be carried out on your end equipment with the power supply installed in accordance with any required EMC/EMI regulations.

MODEL	KHEA/KHNA30F-5	KHEA/KHNA30F-12	KHEA/KHNA30F-24
MAX OUTPUT WATTAGE[W]	25	27.6	31.2
DC OUTPUT	5V 5A	12V 2.3A	24V 1.3A

SPECIFICATIONS

	MODEL	KHEA/KHNA30F-5	KHEA/KHNA30F-12	KHEA/KHNA30F-24	
INPUT	VOLTAGE[V]	AC85 - 264 1 φ (Refer to "Derating") or DC88 - 370 *11			
	CURRENT[A]	ACIN 115V	0.45typ	0.50typ	0.55typ
		ACIN 230V	0.30typ	0.30typ	0.35typ
	FREQUENCY[Hz]	50 / 60 (45 - 440) or DC			
	EFFICIENCY[%]	ACIN 115V	84.0typ	87.0typ	88.5typ
		ACIN 230V	85.5typ	88.5typ	89.5typ
INRUSH CURRENT[A]	ACIN 115V	18typ (Io=100%) (at cold start Ta=25°C)			
	*1 ACIN 230V	35typ (Io=100%) (at cold start Ta=25°C)			
LEAKAGE CURRENT[ma]	0.45 / 0.75max (ACIN 100V / 240V 60Hz, Io=100%, According to IEC62368-1 and DEN-AN)				
OUTPUT	VOLTAGE[V]	5	12	24	
	CURRENT[A]	5.0	2.3	1.3	
	PEAK CURRENT[A]	-	-	-	
	LINE REGULATION[mV]	*2 20max	48max	96max	
	LOAD REGULATION[mV]	*2 80max	100max	150max	
	RIPPLE[mVp-p]	*3	0 to +70°C	150max	150max
			-20 - 0°C	300max	300max
			Io=0 - 30%	300max *4	300max *4
	RIPPLE NOISE[mVp-p]	*3	0 to +70°C	180max	180max
			-20 - 0°C	360max	360max
			Io=0 - 30%	360max *4	360max *4
	TEMPERATURE REGULATION[mV]	0 to +70°C	50max	120max	240max
		-20 to +70°C	60max	150max	290max
	DRIFT[mV]	*5 20max	48max	96max	
START-UP TIME[ms]	200typ (ACIN 115V, Io=100%)				
HOLD-UP TIME[ms]	20typ (ACIN 115V, Io=100%)				
OUTPUT VOLTAGE ADJUSTMENT RANGE[V]	4.50 to 5.50	10.80 to 13.20	22.50 to 28.50		
OUTPUT VOLTAGE SETTING[V]	5.00 to 5.15	12.00 to 12.48	24.00 to 24.96		
PROTECTION CIRCUIT AND OTHERS	OVERCURRENT PROTECTION	Works over 105% of rating and recovers automatically *10			
	OVERVOLTAGE PROTECTION[V]	6.30 to 7.60	13.80 to 16.80	30.00 to 36.00	
	DC_OK LAMP	LED (Green)			
ISOLATION	INPUT-OUTPUT	AC3,000V 1minute, Cutoff current = 10mA, DC500V 50MΩ min (At Room Temperature)			
	INPUT-PE	AC2,000V 1minute, Cutoff current = 10mA, DC500V 50MΩ min (At Room Temperature)			
	OUTPUT-PE	AC500V 1minute, Cutoff current = 100mA, DC500V 50MΩ min (At Room Temperature)			
ENVIRONMENT	OPERATING TEMP., HUMID. AND ALTITUDE	-20 to +70°C, 20 - 90%RH (Non condensing), Type tested for -40°C start-up (Refer to "Derating")			
	STORAGE TEMP., HUMID. AND ALTITUDE	-30 to +85°C, 20 - 90%RH (Non condensing)			
	VIBRATION	*8 10 - 55Hz, 19.6m/s ² (2G), 3minutes period, 60 minutes along Z axis (Non operating, mounted on DIN Rail)			
	IMPACT	196.1m/s ² (20G), 11ms, once each X, Y and Z axis (Packing state)			
SAFETY AND NOISE REGULATIONS	AGENCY APPROVALS	AC input	UL60950-1, C-UL (CSA60950-1), EN62368-1, UL508 (NEC Class2 per UL1310), UL121201, ATEX, Complies with DEN-AN *		
		DC input	UL60950-1, C-UL (CSA60950-1), EN62368-1		
	CONDUCTED NOISE	Complies with FCC-B, VCCI-B, CISPR22-B, EN55011-B, EN55022-B			
	HARMONIC ATTENUATOR	Complies with IEC61000-3-2 (Class A) *6 (Not built-in to active filter) *9			
OTHERS	CASE SIZE	*7 22.5 × 75 × 90mm (W × H × D) [0.89 × 2.95 × 3.54 inches]			
	WEIGHT	165g max			
	COOLING METHOD	Convection			

*1 The value is primary surge. The current of input surge to a built-in EMI/EMC Filter(0.2ms or less)is excluded.
 *2 Please contact us about dynamic load and input response.
 *3 This is the value that measured on measuring board with capacitor of 22μF and 0.1μF at 150mm from output terminal.
 Measured by 20MHz oscilloscope or Ripple-Noise meter (Equivalent to KEISOKU-GIKEN: RM103). Please refer to the instruction manual 1.7.
 Ripple and ripple noise spec is change at Io=0 to 30% by burst operation.
 *4 In case of operating under 0°C ambient temperature, the value is two times of specification at 0 to 30% load factor.
 *5 Drift is the change in DC output for an eight hour period after a half-hour warm-up at 25°C, with the input voltage held constant at the rated input/output.

*6 Please contact us about another class.
 *7 Case size contains neither the umbo.
 *8 Only as standard mounting orientation (A). Refer to the "Assembling and Installation Method". If install other than standard mounting orientation (A), please fix the power supply for withstand the vibration and impact.
 *9 When two or more units are operating it may not comply with the IEC61000-3-2.
 *10 If the overcurrent protection circuit operates continuously, the output voltage shut down. Refer to the instruction manual 1.3.
 *11 Under low DC input voltage below DC110V, the temperature derating -1°C/V or the output power derating -1%/V are required.
 * To meet the specifications. Do not operate over-loaded condition.
 * A sound may occur from power supply at light or peak loading.

Block diagram

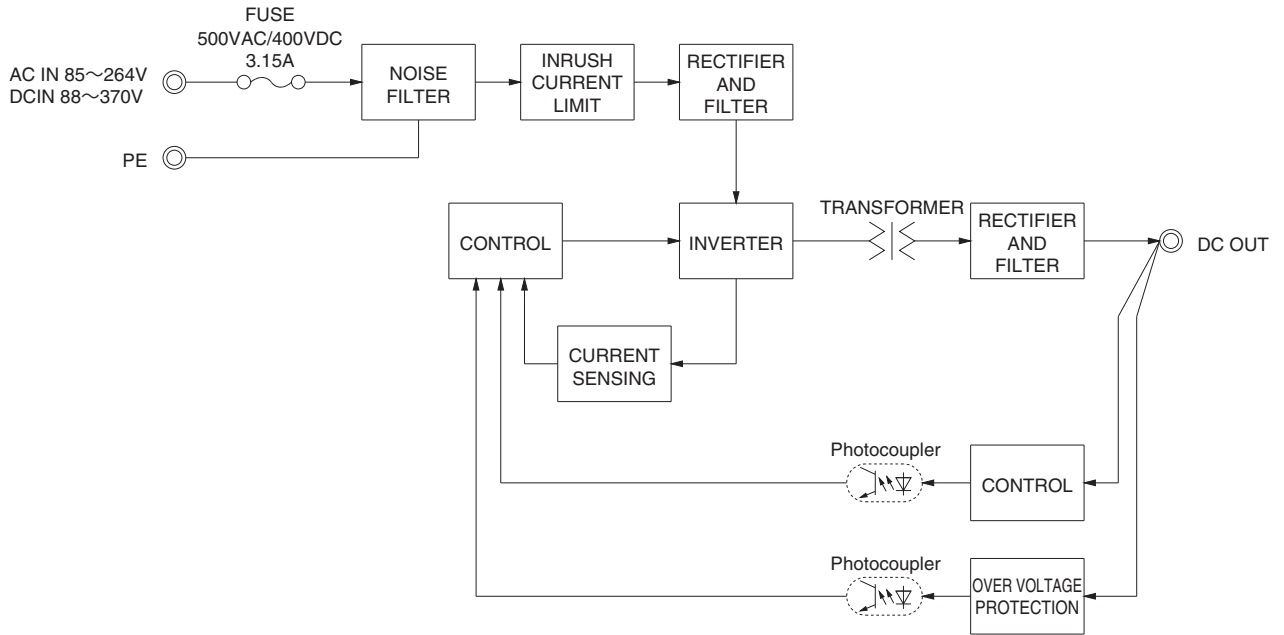

External view

<KHEA30F(Euro Style I/O Terminals)>

<KHNA30F(Barrier Blocks Style I/O Terminals)>

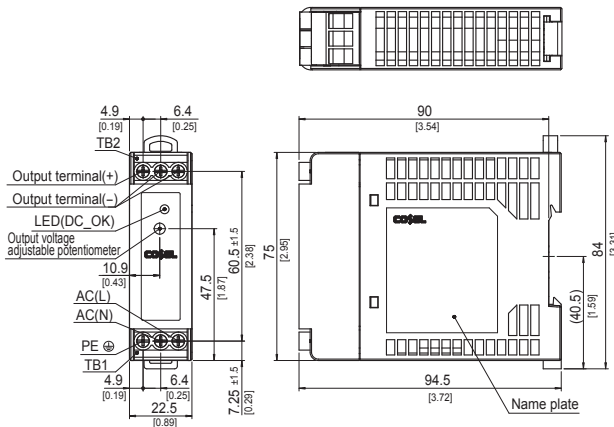

- ※ Tolerance : ± 1 [± 0.04]
- ※ Weight : 165g max
- ※ PCB Material/thickness : FR-4 / 1.6mm [0.06]
- ※ Chassis · Case material : PBT
- ※ Din rail attachment material : PC/ABS
- ※ Dimensions in mm, [] = inches
- ※ Screw tightening torque : 1N · m max

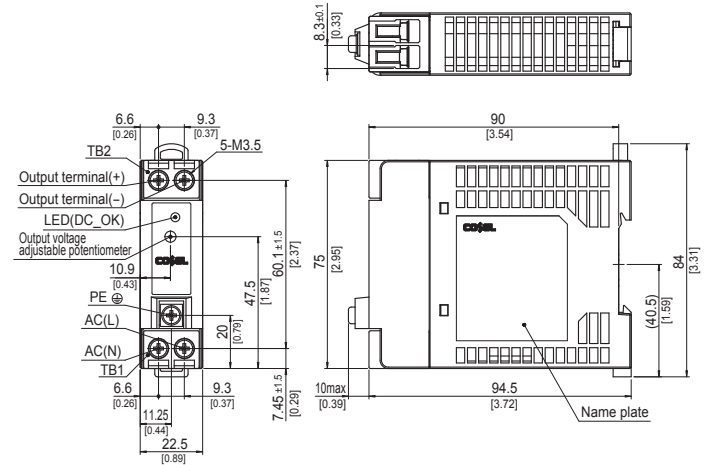

- ※ Tolerance : ± 1 [± 0.04]
- ※ Weight : 165g max
- ※ PCB Material/thickness : FR-4 / 1.6mm [0.06]
- ※ Chassis · Case material : PBT
- ※ Din rail attachment material : PC/ABS
- ※ Dimensions in mm, [] = inches
- ※ Screw tightening torque : 1.1N · m max

KHEA/KHNA60F

KH A 60 F - -

① ② ③ ④ ⑤ ⑥

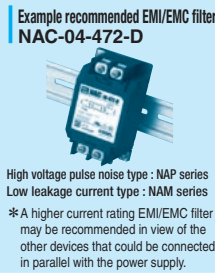

- ① Series name
KHE : Euro style I/O terminals
KHN : Barrier blocks style I/O terminals
- ② Single output
- ③ Output wattage
- ④ Universal input
- ⑤ Output voltage
- ⑥ Option
C : with Coating

*Make sure necessary tests will be carried out on your end equipment with the power supply installed in accordance with any required EMC/EMI regulations.

MODEL	KHEA/KHNA60F-12	KHEA/KHNA60F-24
MAX OUTPUT WATTAGE[W]	54	60
DC OUTPUT	12V 4.5A	24V 2.5A

SPECIFICATIONS

	MODEL	KHEA/KHNA60F-12	KHEA/KHNA60F-24	
INPUT	VOLTAGE[V]	AC85 - 264 1 φ (Refer to "Derating") or DC88 - 370 *11		
	CURRENT[A]	ACIN 115V	1.00typ	1.10typ
		ACIN 230V	0.60typ	0.70typ
	FREQUENCY[Hz]	50 / 60 (45 - 440) or DC		
	EFFICIENCY[%]	ACIN 115V	87.0typ	89.0typ
		ACIN 230V	88.0typ	91.0typ
INRUSH CURRENT[A]	ACIN 115V	18typ (Io=100%) (at cold start Ta=25°C)		
	*1 ACIN 230V	35typ (Io=100%) (at cold start Ta=25°C)		
LEAKAGE CURRENT[ma]	0.45 / 0.75max (ACIN 100V / 240V 60Hz, Io=100%, According to IEC62368-1 and DEN-AN)			
OUTPUT	VOLTAGE[V]	12	24	
	CURRENT[A]	4.5	2.5	
	PEAK CURRENT[A]	-	-	
	LINE REGULATION[mV] *2	48max	96max	
	LOAD REGULATION[mV] *2	100max	150max	
	RIPPLE[mVp-p] *3	0 to +70°C	200max	200max
		-20 - 0°C	300max	300max
		Io=0 - 30%	300max *4	300max *4
	RIPPLE NOISE[mVp-p] *3	0 to +70°C	260max	260max
		-20 - 0°C	360max	360max
		Io=0 - 30%	360max *4	360max *4
	TEMPERATURE REGULATION[mV]	0 to +70°C	120max	240max
		-20 to +70°C	150max	290max
	DRIFT[mV] *5	48max	96max	
START-UP TIME[ms]	200typ (ACIN 115V, Io=100%)			
HOLD-UP TIME[ms]	20typ (ACIN 115V, Io=100%)			
OUTPUT VOLTAGE ADJUSTMENT RANGE[V]	10.80 to 13.20	22.50 to 28.50		
OUTPUT VOLTAGE SETTING[V]	12.00 to 12.48	24.00 to 24.96		
PROTECTION CIRCUIT AND OTHERS	OVERCURRENT PROTECTION	Works over 105% of rating and recovers automatically *10		
	OVERVOLTAGE PROTECTION[V]	13.80 to 16.80	30.00 to 36.00	
	DC_OK LAMP	LED (Green)		
ISOLATION	INPUT-OUTPUT	AC3,000V 1minute, Cutoff current = 10mA, DC500V 50MΩ min (At Room Temperature)		
	INPUT-PE	AC2,000V 1minute, Cutoff current = 10mA, DC500V 50MΩ min (At Room Temperature)		
	OUTPUT-PE	AC500V 1minute, Cutoff current = 100mA, DC500V 50MΩ min (At Room Temperature)		
ENVIRONMENT	OPERATING TEMP., HUMID. AND ALTITUDE	-20 to +70°C, 20 - 90%RH (Non condensing), Type tested for -40°C start-up (Refer to "Derating")		
	STORAGE TEMP., HUMID. AND ALTITUDE	-30 to +85°C, 20 - 90%RH (Non condensing)		
	VIBRATION *8	10 - 55Hz, 19.6m/s ² (2G), 3minutes period, 60 minutes along Z axis (Non operating, mounted on DIN Rail)		
	IMPACT	196.1m/s ² (20G), 11ms, once each X, Y and Z axis (Packing state)		
SAFETY AND NOISE REGULATIONS	AGENCY APPROVALS	AC input	UL60950-1, C-UL (CSA60950-1), EN62368-1, UL508 (NEC Class2 per UL1310), UL121201, ATEX, Complies with DEN-AN *	
		DC input	UL60950-1, C-UL (CSA60950-1), EN62368-1	
	CONDUCTED NOISE	Complies with FCC-B, VCCI-B, CISPR22-B, EN55011-B, EN55022-B		
	HARMONIC ATTENUATOR	Complies with IEC61000-3-2 (Class A) *6 (Not built-in to active filter) *9		
OTHERS	CASE SIZE *7	32×90×90mm (W×H×D) [1.26×3.54×3.54 inches]		
	WEIGHT	270g max		
	COOLING METHOD	Convection		

*1 The value is primary surge. The current of input surge to a built-in EMI/EMC Filter(0.2ms or less)is excluded.
 *2 Please contact us about dynamic load and input response.
 *3 This is the value that measured on measuring board with capacitor of 22μF and 0.1μF at 150mm from output terminal.
 Measured by 20MHz oscilloscope or Ripple-Noise meter (Equivalent to KEISOKU-GIKEN: RM103). Please refer to the instruction manual 1.7.
 Ripple and ripple noise spec is change at Io=0 to 30% by burst operation.
 *4 In case of operating under 0°C ambient temperature, the value is two times of specification at 0 to 30% load factor.
 *5 Drift is the change in DC output for an eight hour period after a half-hour warm-up at 25°C, with the input voltage held constant at the rated input/output.

*6 Please contact us about another class.
 *7 Case size contains neither the umbo.
 *8 Only as standard mounting orientation (A). Refer to the "Assembling and Installation Method". If install other than standard mounting orientation (A), please fix the power supply for withstand the vibration and impact.
 *9 When two or more units are operating it may not comply with the IEC61000-3-2.
 *10 If the overcurrent protection circuit operates continuously, the output voltage shut down. Refer to the instruction manual 1.3.
 *11 Under low DC input voltage below DC110V, the temperature derating -1°C/V or the output power derating -1%/V are required.
 * To meet the specifications. Do not operate over-loaded condition.
 * A sound may occur from power supply at light or peak loading.

Block diagram

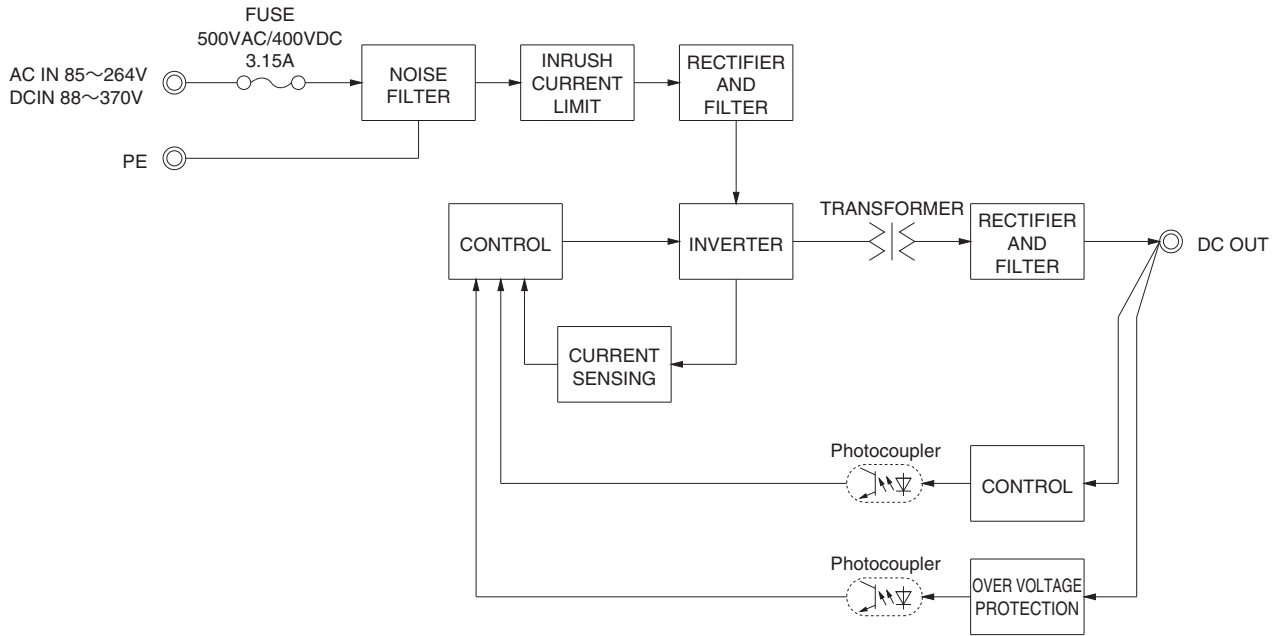

External view

<KHEA60F(Euro Style I/O Terminals)>

<KHNA60F(Barrier Blocks Style I/O Terminals)>

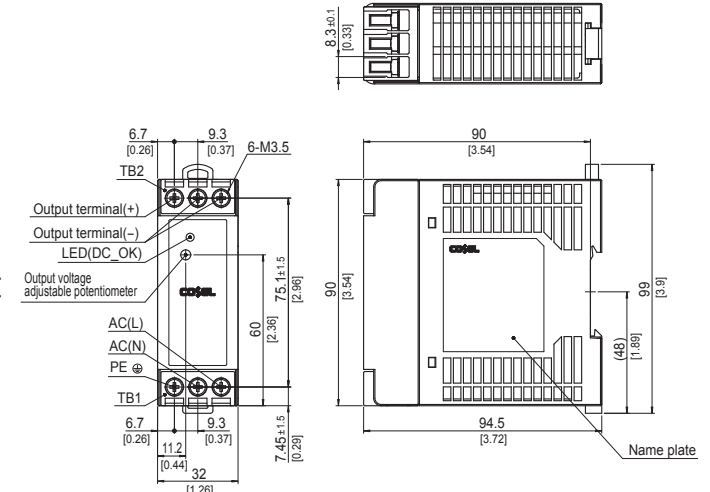
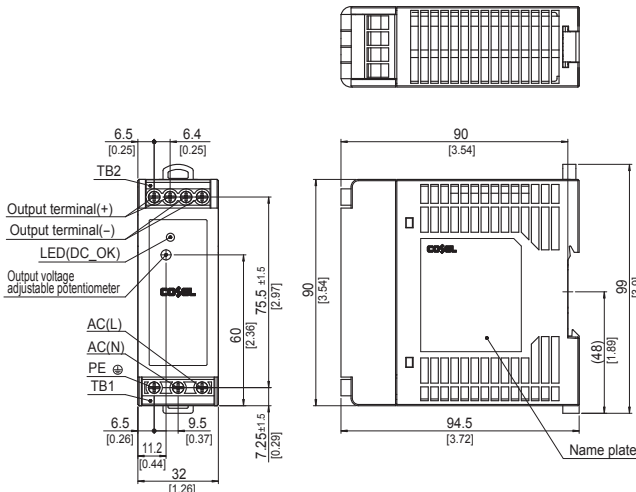

- ※ Tolerance : ±1 [±0.04]
- ※ Weight : 270g max
- ※ PCB Material/thickness : FR-4 / 1.6mm [0.06]
- ※ Chassis · Case material : PBT
- ※ Din rail attachment material : PC/ABS
- ※ Dimensions in mm, [] = inches
- ※ Screw tightening torque : 1N · m max

- ※ Tolerance : ±1 [±0.04]
- ※ Weight : 270g max
- ※ PCB Material/thickness : FR-4 / 1.6mm [0.06]
- ※ Chassis · Case material : PBT
- ※ Din rail attachment material : PC/ABS
- ※ Dimensions in mm, [] = inches
- ※ Screw tightening torque : 1.1N · m max

KHEA/KHNA90F

KH A 90 F - -

① ② ③ ④ ⑤ ⑥

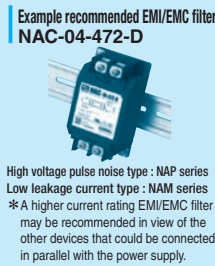

- ① Series name
KHE : Euro style I/O terminals
KHN : Barrier blocks style I/O terminals
- ② Single output
- ③ Output wattage
- ④ Universal input
- ⑤ Output voltage
- ⑥ Option
C : with Coating
E : NEC Class2 (24V)

* Make sure necessary tests will be carried out on your end equipment with the power supply installed in accordance with any required EMC/EMI regulations.

MODEL	KHEA/KHNA90F-12	KHEA/KHNA90F-24
MAX OUTPUT WATTAGE[W]	81.6	91.2
DC OUTPUT	12V 6.8A	24V 3.8A

SPECIFICATIONS

	MODEL	KHEA/KHNA90F-12	KHEA/KHNA90F-24	
INPUT	VOLTAGE[V]	AC85 - 264 1 φ (Refer to "Derating") or DC88-250 *10		
	CURRENT[A]	ACIN 115V	0.85typ	0.95typ
		ACIN 230V	0.45typ	0.55typ
	FREQUENCY[Hz]	50 / 60 (45 - 66) or DC		
	EFFICIENCY[%]	ACIN 115V	87.0typ	89.0typ (88.0typ for option -E)
		ACIN 230V	88.0typ	91.0typ (89.5typ for option -E)
	POWER FACTOR (Io=100%)	ACIN 115V	0.98typ	
		ACIN 230V	0.86typ	
INRUSH CURRENT[A]	ACIN 115V	18typ (Io=100%) (at cold start Ta=25°C)		
	*1 ACIN 230V	35typ (Io=100%) (at cold start Ta=25°C)		
LEAKAGE CURRENT[ma]	0.45 / 0.75max (ACIN 100V / 240V 60Hz, Io=100%, According to IEC62368-1 and DEN-AN)			
OUTPUT	VOLTAGE[V]	12	24	
	CURRENT[A]	6.8	3.8	
	PEAK CURRENT[A]	-	-	
	LINE REGULATION[mV] *2	48max	96max	
	LOAD REGULATION[mV] *2	100max	150max	
	RIPPLE[mVp-p] *3	0 to +70°C	200max	200max
		-20 - 0°C	300max	300max
		Io=0 - 30%	300max *4	300max *4
	RIPPLE NOISE[mVp-p] *3	0 to +70°C	260max	260max
		-20 - 0°C	360max	360max
		Io=0 - 30%	360max *4	360max *4
	TEMPERATURE REGULATION[mV]	0 to +70°C	120max	240max
		-20 to +70°C	150max	290max
	DRIFT[mV] *5	48max	96max	
	START-UP TIME[ms]	500typ (ACIN 115V, Io=100%)		
HOLD-UP TIME[ms]	20typ (ACIN 115V, Io=100%)			
OUTPUT VOLTAGE ADJUSTMENT RANGE[V]	10.80 to 13.20	22.50 to 28.50 (Fixed for option -E)		
OUTPUT VOLTAGE SETTING[V]	12.00 to 12.48	24.00 to 24.96 (24.00 to 24.50 for option -E)		
PROTECTION CIRCUIT AND OTHERS	OVERCURRENT PROTECTION	Works over 105% of rating (101% for option -E), recovers automatically *9		
	OVERVOLTAGE PROTECTION[V]	13.80 to 16.80	30.00 to 36.00 (26.40 to 33.60 for option -E)	
	DC_OK LAMP	LED (Green)		
ISOLATION	INPUT-OUTPUT	AC3,000V 1minute, Cutoff current = 10mA, DC500V 50MΩ min (At Room Temperature)		
	INPUT-PE	AC2,000V 1minute, Cutoff current = 10mA, DC500V 50MΩ min (At Room Temperature)		
	OUTPUT-PE	AC500V 1minute, Cutoff current = 100mA, DC500V 50MΩ min (At Room Temperature)		
ENVIRONMENT	OPERATING TEMP., HUMID. AND ALTITUDE	-20 to +70°C, 20 - 90%RH (Non condensing), Type tested for -40°C start-up (Refer to "Derating")		
	STORAGE TEMP., HUMID. AND ALTITUDE	-30 to +85°C, 20 - 90%RH (Non condensing)		
	VIBRATION *8	10 - 55Hz, 19.6m/s ² (2G), 3minutes period, 60 minutes along Z axis (Non operating, mounted on DIN Rail)		
	IMPACT	196.1m/s ² (20G), 11ms, X, Y and Z axis (Packing state)		
SAFETY AND NOISE REGULATIONS	AGENCY APPROVALS	AC input	UL60950-1, C-UL (CSA60950-1), EN62368-1, UL508, NEC Class2 (24V output only option -E), UL121201, ATEX, Complies with DEN-AN	
		DC input	UL60950-1, C-UL (CSA60950-1), EN62368-1	
	CONDUCTED NOISE	Complies with FCC-B, VCCI-B, CISPR22-B, EN55011-B, EN55022-B		
	HARMONIC ATTENUATOR	Complies with IEC61000-3-2 (Class A) *6		
OTHERS	CASE SIZE *7	50×90×90mm (W×H×D) [1.97×3.54×3.54 inches]		
	WEIGHT	405g max		
	COOLING METHOD	Convection		

*1 The value is primary surge. The current of input surge to a built-in EMI/EMC Filter(0.2ms or less)is excluded.
 *2 Please contact us about dynamic load and input response.
 *3 This is the value that measured on measuring board with capacitor of 22 μF and 0.1 μF at 150mm from output terminal.
 Measured by 20MHz oscilloscope or Ripple-Noise meter (Equivalent to KEISOKU-GIKEN: RM103). Please refer to the instruction manual 1.7.
 Ripple and ripple noise spec is change at Io=0 to 30% by burst operation.
 *4 In case of operating under 0°C ambient temperature, the value is two times of specification at 0 to 30% load factor.
 *5 Drift is the change in DC output for an eight hour period after a half-hour warm-up at 25°C, with the

input voltage held constant at the rated input/output.
 *6 Please contact us about another class.
 *7 Case size contains neither the umbo.
 *8 Only as standard mounting orientation (A). Refer to the "Assembling and Installation Method". If install other than standard mounting orientation (A), please fix the power supply for withstand the vibration and impact.
 *9 If the overcurrent protection circuit operates continuously, the output voltage shut down. Refer to the instruction manual 1.3.
 *10 Under low DC input voltage below DC110V, the temperature derating -1°C/V or the output power derating -1%/V are required.
 * To meet the specifications. Do not operate over-loaded condition.
 * A sound may occur from power supply at light or peak loading.

Block diagram

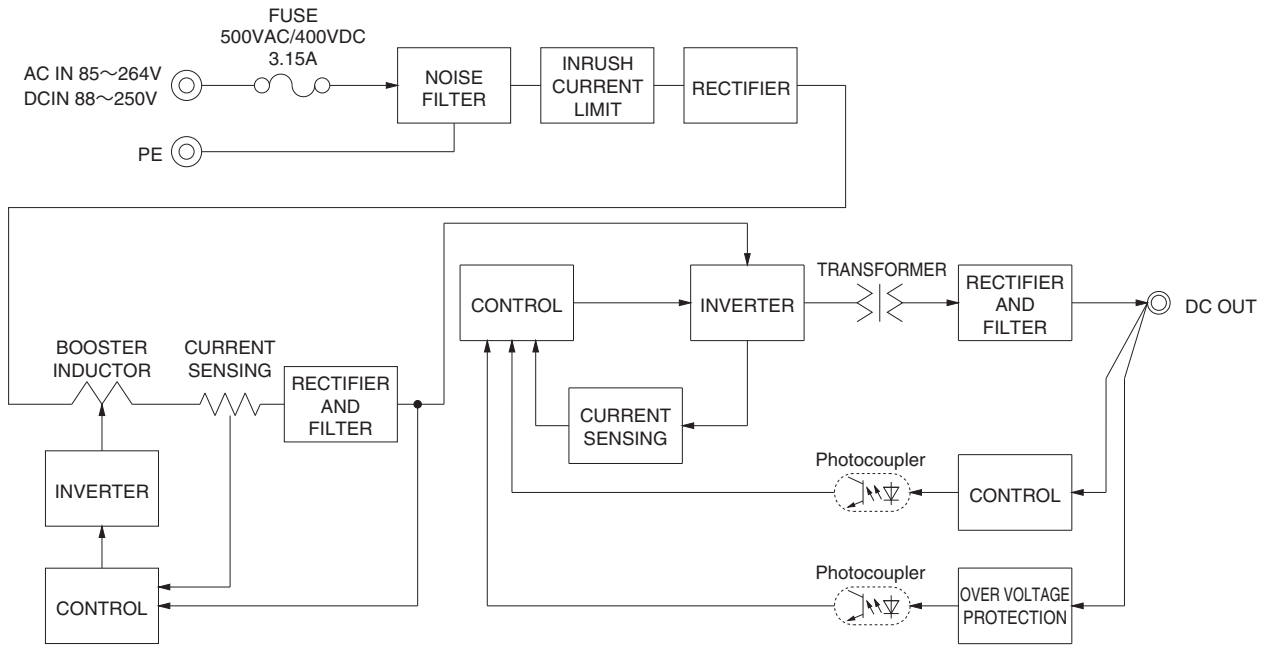

External view

<KHEA90F(Euro Style I/O Terminals)>

<KHNA90F(Barrier Blocks Style I/O Terminals)>

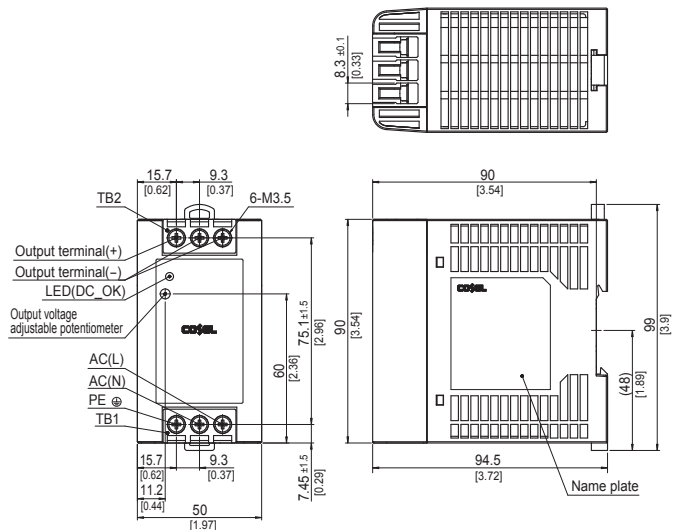
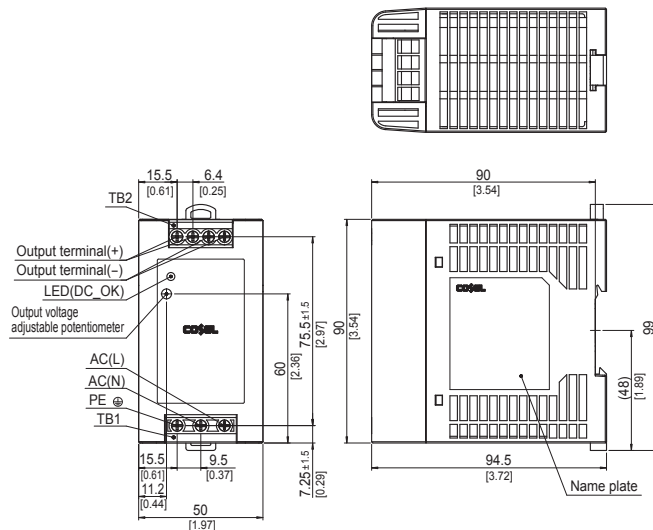

- ※ Tolerance : ± 1 [± 0.04]
- ※ Weight : 405g max
- ※ PCB Material/thickness : FR-4 / 1.6mm [0.06]
- ※ Chassis · Case material : PBT
- ※ Din rail attachment material : PC/ABS
- ※ Dimensions in mm, [] = inches
- ※ Screw tightening torque : 1N · m max

- ※ Tolerance : ± 1 [± 0.04]
- ※ Weight : 405g max
- ※ PCB Material/thickness : FR-4 / 1.6mm [0.06]
- ※ Chassis · Case material : PBT
- ※ Din rail attachment material : PC/ABS
- ※ Dimensions in mm, [] = inches
- ※ Screw tightening torque : 1.1N · m max

KHEA/KHNA120F

KH A -120 F -24 -

① ② ③ ④ ⑤ ⑥



Example recommended EMI/EMC filter
NAC-04-472-D



High voltage pulse noise type : NAP series
Low leakage current type : NAM series
* A higher current rating EMI/EMC filter may be recommended in view of the other devices that could be connected in parallel with the power supply.

- ① Series name
KHE : Euro style I/O terminals
KHN : Barrier blocks style I/O terminals
- ② Single output
- ③ Output wattage
- ④ Universal input
- ⑤ Output voltage
- ⑥ Option
C : with Coating
N2: Screw mounting

*Make sure necessary tests will be carried out on your end equipment with the power supply installed in accordance with any required EMC/EMI regulations.

MODEL	KHEA / KHNA120F-24
MAX OUTPUT WATTAGE[W]	120
DC OUTPUT	24V 5A (Peak 7.5A)

SPECIFICATIONS

	MODEL	KHEA / KHNA120F-24	
INPUT	VOLTAGE[V]	AC85 - 264 1 φ or DC88 - 370 *10	
	CURRENT[A]	ACIN 115V	1.2typ
		ACIN 230V	0.6typ
	FREQUENCY[Hz]	50 / 60 (45 - 66) or DC	
	EFFICIENCY[%]	ACIN 115V	90typ
		ACIN 230V	92typ
	POWER FACTOR	ACIN 115V	0.98typ
		ACIN 230V	0.93typ
	INRUSH CURRENT[A]	ACIN 115V	15typ (at cold start Ta=25°C)
		*1 ACIN 230V	30typ (at cold start Ta=25°C)
LEAKAGE CURRENT[ma]	0.45 / 0.75max (ACIN 100V / 240V 60Hz, Io=100%, According to IEC62368-1 and DEN-AN)		
OUTPUT	VOLTAGE[V]	24	
	CURRENT[A]	5	
	PEAK CURRENT[A]	*2 7.5	
	LINE REGULATION[mV]	*3 96max	
	LOAD REGULATION[mV]	*3 150max *4	
	RIPPLE[mVp-p]	0 to +70°C	120max
		*5 -25 - 0°C	240max
		Io=0 - 30%	240max *4
	RIPPLE NOISE[mVp-p]	0 to +70°C	150max
		*5 -25 - 0°C	300max
		Io=0 - 30%	300max *4
	TEMPERATURE REGULATION[mV]	0 to +70°C	240max *4
		-25 to +70°C	360max *4
	DRIFT[mV]	*6 96max	
	START-UP TIME[ms]	750max (ACIN 115V, Io=100%)	
HOLD-UP TIME[ms]	20typ (ACIN 115V, Io=100%)		
OUTPUT VOLTAGE ADJUSTMENT RANGE[V]	22.5 to 28.5		
OUTPUT VOLTAGE SETTING[V]	24.0±1.0%		
PROTECTION CIRCUIT AND OTHERS	OVERCURRENT PROTECTION	Works over 101% of peak current and recovers automatically	
	OVERVOLTAGE PROTECTION[V]	30.0 to 36.0	
	REMOTE ON/OFF (RC)	Provided	
	DC_OK LAMP	LED (Green)	
	ALARM LAMP	LED (Red)	
DC_OK CONTACT	Relay contact 30VDC 1A max, 30VAC 0.5A max (resistive load) (Only KHEA)		
ISOLATION	INPUT-OUTPUT	AC3,000V 1minute, Cutoff current = 10mA, DC500V 50MΩ min (At Room Temperature)	
	INPUT-PE	AC2,000V 1minute, Cutoff current = 10mA, DC500V 50MΩ min (At Room Temperature)	
	OUTPUT-PE	AC500V 1minute, Cutoff current = 100mA, DC500V 50MΩ min (At Room Temperature)	
	OUTPUT-RC, DC_OK	AC500V 1minute, Cutoff current = 100mA, DC500V 50MΩ min (At Room Temperature)	
ENVIRONMENT	OPERATING TEMP., HUMID. AND ALTITUDE	-25 to +70°C, 20 - 90%RH (Non condensing), Type tested for -40°C start-up (Refer to "Derating")	
	STORAGE TEMP., HUMID. AND ALTITUDE	-40 to +85°C, 20 - 90%RH (Non condensing)	
	VIBRATION	*9 10 - 55Hz, 19.6m/s ² (2G), 3minutes period, 60 minutes along Z axis (Non operating, mounted on DIN Rail)	
	IMPACT	196.1m/s ² (20G), 11ms, once each X, Y and Z axis (Packing state)	
SAFETY AND NOISE REGULATIONS	AGENCY APPROVALS	AC input	UL60950-1, C-UL (CSA60950-1), EN62368-1, UL508, UL121201, ATEX, GL, Complies with DEN-AN
		DC input	UL60950-1, C-UL (CSA60950-1), EN62368-1
	CONDUCTED NOISE	Complies with FCC-B, VCCI-B, CISPR22-B, EN55011-B, EN55022-B	
HARMONIC ATTENUATOR	Complies with IEC61000-3-2 (Class A) *7		
OTHERS	CASE SIZE	*8 37×124×117mm (W×H×D) [1.46×4.88×4.61 inches]	
	WEIGHT	580g max	
	COOLING METHOD	Convection	

- *1 The value is primary surge. The current of input surge to a built-in EMI/EMC Filter(0.2ms or less)is excluded.
- *2 Refer to 2, instruction manual.
- *3 Please contact us about dynamic load and input response.
- *4 The output voltage is below 23.5V, the value is equal to three times of the specification.
- *5 This is the value that measured on measuring board with capacitor of 22 μF and 0.1 μF at 150mm from output terminal.

- Measured by 20MHz oscilloscope or Ripple-Noise meter (Equivalent to KEISOKU-GIKEN: RM103). Please refer to the instruction manual 1.7.
- *6 Drift is the change in DC output for an eight hour period after a half-hour warm-up at 25 C, with the input voltage held constant at the rated input/output.
- *7 Please contact us about another class.
- *8 Case size contains neither the umbo.

- *9 Only as standard mounting orientation (A). Refer to the "Assembling and Installation Method". If install other than standard mounting orientation (A), please fix the power supply for withstand the vibration and impact.
- *10 Under low DC input voltage below DC110V, the temperature derating -1C/V or the output power derating -1%/V are required.
- * To meet the specifications. Do not operate over-loaded condition.
- * A sound may occur from power supply at light or peak loading.

Block diagram

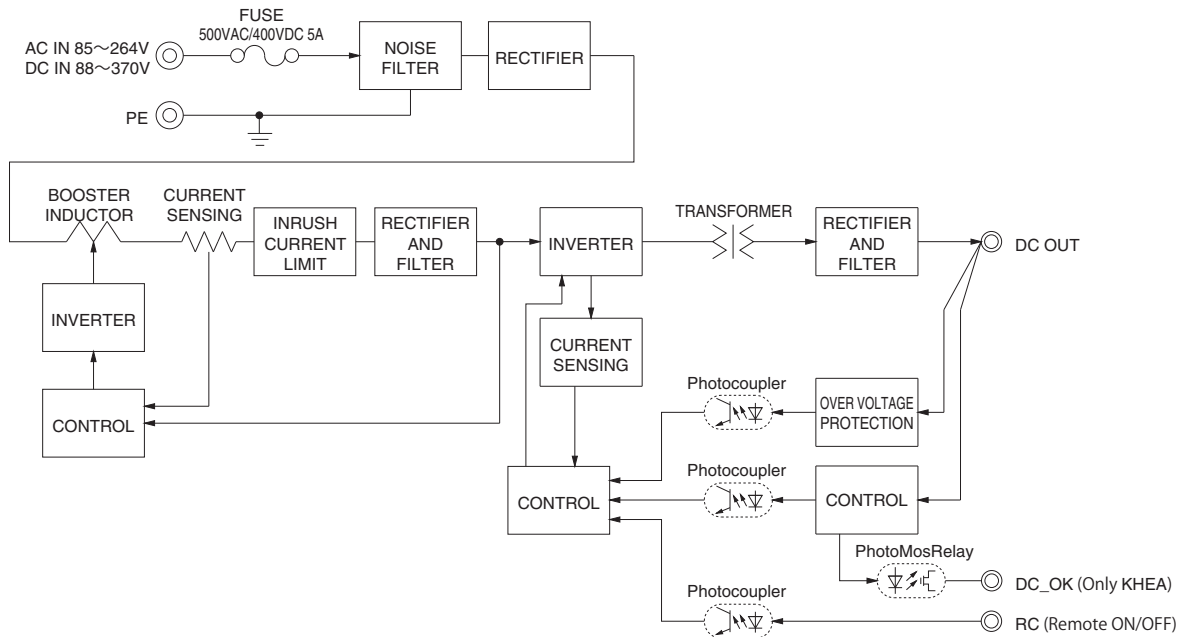

External view

<KHEA120F(Euro Style I/O Terminals)>

<KHNA120F(Barrier Blocks Style I/O Terminals)>

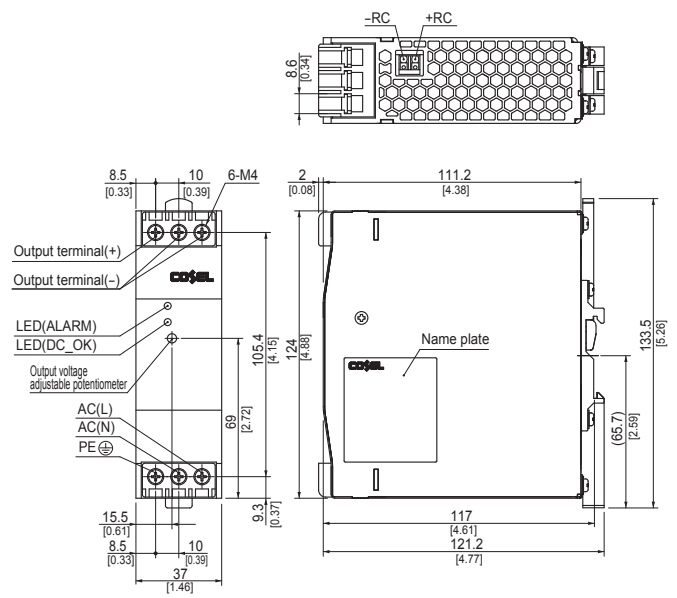
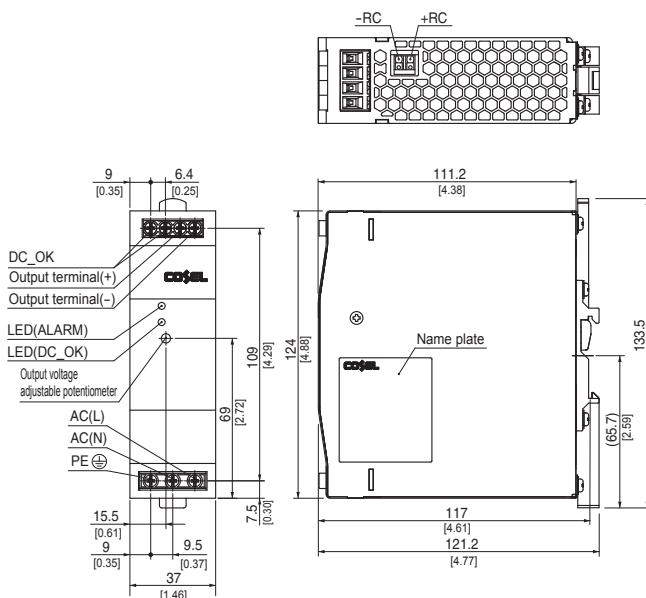

- ※ Tolerance : ±1 [±0.04]
- ※ Weight : 580g max
- ※ PCB Material/thickness : FR-4 / 1.6mm [0.06]
- ※ Chassis material : Aluminum
- ※ Case material : Stainless steel
- ※ DIN rail attachment material : Aluminum, Stainless steel, Nylon
- ※ Dimensions in mm, [] = inches
- ※ Screw tightening torque : 1N · m max

- ※ Tolerance : ±1 [±0.04]
- ※ Weight : 580g max
- ※ PCB Material/thickness : FR-4 / 1.6mm [0.06]
- ※ Chassis material : Aluminum
- ※ Case material : Stainless steel
- ※ DIN rail attachment material : Aluminum, Stainless steel, Nylon
- ※ Dimensions in mm, [] = inches
- ※ Screw tightening torque : 1.6N · m max

KHEA/KHNA240F

KH A -240 F -24 -

① ② ③ ④ ⑤ ⑥



Example recommended EMI/EMC filter
NAC-06-472-D



High voltage pulse noise type : NAP series
Low leakage current type : NAM series
* A higher current rating EMI/EMC filter may be recommended in view of the other devices that could be connected in parallel with the power supply.

- ① Series name
KHE : Euro style I/O terminals
KHN : Barrier blocks style I/O terminals
- ② Single output
- ③ Output wattage
- ④ Universal input
- ⑤ Output voltage
- ⑥ Option
C : with Coating
N2: Screw mounting

*Make sure necessary tests will be carried out on your end equipment with the power supply installed in accordance with any required EMC/EMI regulations.

MODEL	KHEA / KHNA240F-24
MAX OUTPUT WATTAGE[W]	240
DC OUTPUT	24V 10A (Peak 15A)

SPECIFICATIONS

	MODEL	KHEA / KHNA240F-24	
INPUT	VOLTAGE[V]	AC85 - 264 1 φ or DC88 - 370 *10	
	CURRENT[A]	ACIN 115V	2.3typ
		ACIN 230V	1.2typ
	FREQUENCY[Hz]	50 / 60 (45 - 66) or DC	
	EFFICIENCY[%]	ACIN 115V	92typ
		ACIN 230V	94typ
	POWER FACTOR	ACIN 115V	0.98typ
		ACIN 230V	0.93typ
INRUSH CURRENT[A]	ACIN 115V	20typ (more than 3 sec. to re-start)	
	*1 ACIN 230V	40typ (more than 3 sec. to re-start)	
LEAKAGE CURRENT[ma]	0.45 / 0.75max (ACIN 100V / 240V 60Hz, Io=100%, According to IEC62368-1 and DEN-AN)		
OUTPUT	VOLTAGE[V]	24	
	CURRENT[A]	10	
	PEAK CURRENT[A]	*2 15	
	LINE REGULATION[mV]	*3 96max	
	LOAD REGULATION[mV]	*3 150max *4	
	RIPPLE[mVp-p]	0 to +70°C	120max
		*5 -25 - 0°C	240max
		Io=0 - 30%	240max *4
	RIPPLE NOISE[mVp-p]	0 to +70°C	150max
		*5 -25 - 0°C	300max
		Io=0 - 30%	300max *4
	TEMPERATURE REGULATION[mV]	0 to +70°C	240max *4
		-25 to +70°C	360max *4
	DRIFT[mV]	*6 96max	
START-UP TIME[ms]	750max (ACIN 115V, Io=100%)		
HOLD-UP TIME[ms]	20typ (ACIN 115V, Io=100%)		
OUTPUT VOLTAGE ADJUSTMENT RANGE[V]	22.5 to 28.5		
OUTPUT VOLTAGE SETTING[V]	24.0 ± 1.0%		
PROTECTION CIRCUIT AND OTHERS	OVERCURRENT PROTECTION	Works over 101% of peak current and recovers automatically	
	OVERVOLTAGE PROTECTION[V]	30.0 to 36.0	
	REMOTE ON/OFF (RC)	Provided	
	DC_OK LAMP	LED (Green)	
	ALARM LAMP	LED (Red)	
DC_OK CONTACT	Relay contact 30VDC 1A max, 30VAC 0.5A max (resistive load) (Only KHEA)		
ISOLATION	INPUT-OUTPUT	AC3,000V 1minute, Cutoff current = 10mA, DC500V 50MΩ min (At Room Temperature)	
	INPUT-PE	AC2,000V 1minute, Cutoff current = 10mA, DC500V 50MΩ min (At Room Temperature)	
	OUTPUT-PE	AC500V 1minute, Cutoff current = 100mA, DC500V 50MΩ min (At Room Temperature)	
	OUTPUT-RC, DC_OK	AC500V 1minute, Cutoff current = 100mA, DC500V 50MΩ min (At Room Temperature)	
ENVIRONMENT	OPERATING TEMP., HUMID. AND ALTITUDE	-25 to +70°C, 20 - 90%RH (Non condensing), Type tested for -40°C start-up (Refer to "Derating")	
	STORAGE TEMP., HUMID. AND ALTITUDE	-40 to +85°C, 20 - 90%RH (Non condensing)	
	VIBRATION	*9	10 - 55Hz, 19.6m/s ² (2G), 3minutes period, 60 minutes along Z axis (Non operating, mounted on DIN Rail)
	IMPACT	196.1m/s ² (20G), 11ms, once each X, Y and Z axis (Packing state)	
SAFETY AND NOISE REGULATIONS	AGENCY APPROVALS	AC input	UL62368-1, C-UL (equivalent to CAN/CSA-C22.2 No. 62368-1), EN62368-1, UL508, UL121201, ATEX, GL, Complies with DEN-AN
		DC input	UL62368-1, C-UL (equivalent to CAN/CSA-C22.2 No. 62368-1), EN62368-1
	CONDUCTED NOISE	Complies with FCC-B, VCCI-B, CISPR22-B, EN55011-B, EN55022-B	
	HARMONIC ATTENUATOR	Complies with IEC61000-3-2 (Class A) *7	
OTHERS	CASE SIZE	*8	50 × 124 × 117mm (W × H × D) [1.97 × 4.88 × 4.61 inches]
	WEIGHT	900g max	
	COOLING METHOD	Convection	

- *1 The value is primary surge. The current of input surge to a built-in EMI/EMC Filter(0.2ms or less)is excluded.
- *2 Refer to 2, instruction manual.
- *3 Please contact us about dynamic load and input response.
- *4 The output voltage is below 23.5V, the value is equal to three times of the specification.
- *5 This is the value that measured on measuring board with capacitor of 22 μ F and 0.1 μ F at 150mm from output terminal.

- Measured by 20MHz oscilloscope or Ripple-Noise meter (Equivalent to KEISOKU-GIKEN: RM103). Please refer to the instruction manual 1.7.
- *6 Drift is the change in DC output for a eight hour period after a half-hour warm-up at 25 C , with the input voltage held constant at the rated input/output.
- *7 Please contact us about another class.
- *8 Case size contains neither the umbo.

- *9 Only as standard mounting orientation (A). Refer to the "Assembling and Installation Method". If install other than standard mounting orientation (A), please fix the power supply for withstand the vibration and impact.
- *10 Under low DC input voltage below DC110V, the temperature derating -1C/V or the output power derating -1%/V are required.
- * To meet the specifications. Do not operate over-loaded condition.
- * A sound may occur from power supply at light or peak loading.

Block diagram

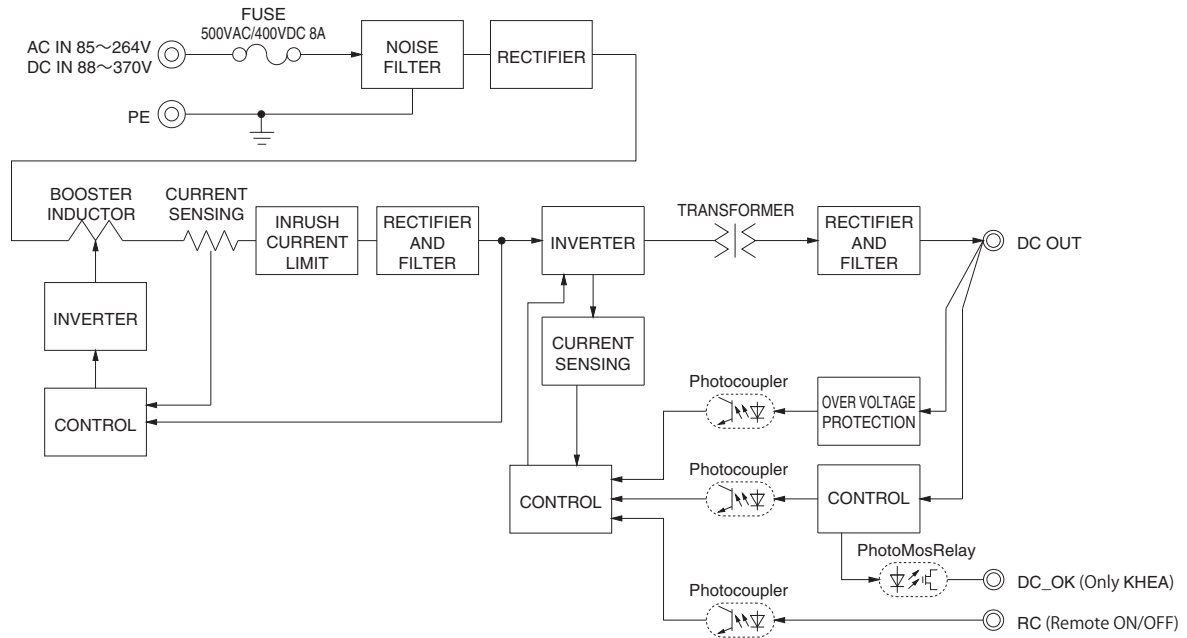

External view

<KHEA240F(Euro Style I/O Terminals)>

<KHNA240F(Barrier Blocks Style I/O Terminals)>

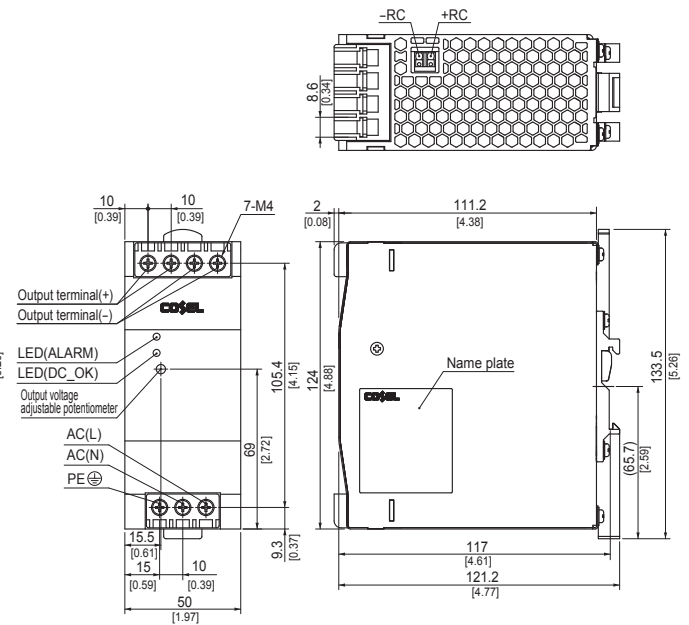
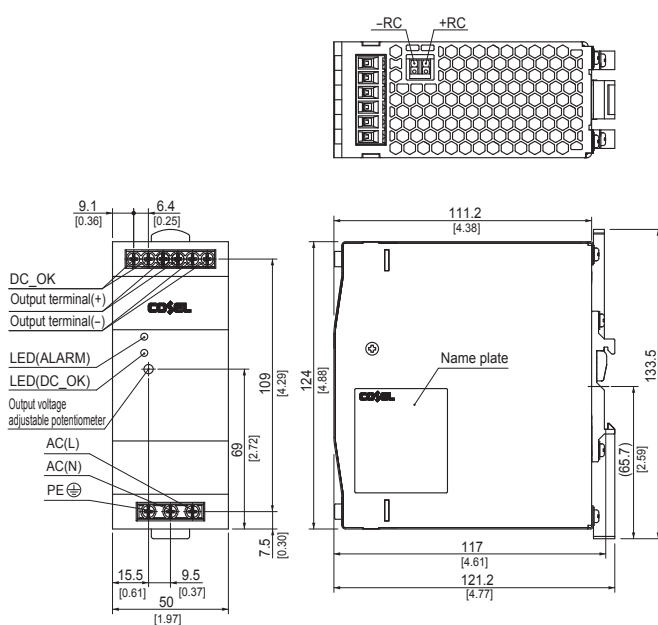

- ※ Tolerance : ± 1 [± 0.04]
- ※ Weight : 900g max
- ※ PCB Material/thickness : FR-4 / 1.6mm [0.06]
- ※ Chassis material : Aluminum
- ※ Case material : Stainless steel
- ※ DIN rail attachment material : Aluminum, Stainless steel, Nylon
- ※ Dimensions in mm, [] = inches
- ※ Screw tightening torque : 1N · m max

- ※ Tolerance : ± 1 [± 0.04]
- ※ Weight : 900g max
- ※ PCB Material/thickness : FR-4 / 1.6mm [0.06]
- ※ Chassis material : Aluminum
- ※ Case material : Stainless steel
- ※ DIN rail attachment material : Aluminum, Stainless steel, Nylon
- ※ Dimensions in mm, [] = inches
- ※ Screw tightening torque : 1.6N · m max

KHEA/KHNA480F

KH A 480 F - -

① ② ③ ④ ⑤ ⑥



Example recommended EMI/EMC filter
NAC-10-472-D



High voltage pulse noise type : NAP series
Low leakage current type : NAM series
* A higher current rating EMI/EMC filter may be recommended in view of the other devices that could be connected in parallel with the power supply.

- ① Series name
KHE : Euro style I/O terminals
KHN : Barrier blocks style I/O terminals
- ② Single output
- ③ Output wattage
- ④ Universal input
- ⑤ Output voltage
- ⑥ Option
C : with Coating
N2: Screw mounting

*Make sure necessary tests will be carried out on your end equipment with the power supply installed in accordance with any required EMC/EMI regulations.

MODEL	KHEA / KHNA480F-24	KHEA / KHNA480F-48
MAX OUTPUT WATTAGE[W]	480	480
DC OUTPUT	24V 20A (Peak 30A)	48V 10A (Peak 15A)

SPECIFICATIONS

	MODEL	KHEA / KHNA480F-24	KHEA / KHNA480F-48	
INPUT	VOLTAGE[V]	AC85 - 264 1 φ (Output derating is required) or DC88 - 350 *10		
	CURRENT[A]	ACIN 115V	4.6typ	
		ACIN 230V	2.3typ	
	FREQUENCY[Hz]	50 / 60 (45 - 66) or DC		
	EFFICIENCY[%]	ACIN 115V	92typ	
		ACIN 230V	94typ	
	POWER FACTOR	ACIN 115V	0.98typ	
		ACIN 230V	0.93typ	
INRUSH CURRENT[A]	ACIN 115V	20typ (more than 3 sec. to re-start)		
	*1 ACIN 230V	40typ (more than 3 sec. to re-start)		
LEAKAGE CURRENT[ma]	0.75 / 1.5max (ACIN 100V / 240V 60Hz, Io=100%, According to IEC62368-1 and DEN-AN)			
OUTPUT	VOLTAGE[V]	24	48	
	CURRENT[A]	20	10	
	PEAK CURRENT[A]	*2 30	15	
	LINE REGULATION[mV]	*3 96max (Io=30-100%) *9	192max (Io=30-100%) *9	
	LOAD REGULATION[mV]	*3 150max (Io=30-100%) *9	300max (Io=30-100%) *9	
	RIPPLE[mVp-p]	0 to +70°C	120max	120max
		-25 - 0°C	240max	240max
		Io=0 - 30%	500max	750max
	RIPPLE NOISE[mVp-p]	0 to +70°C	150max	150max
		-25 - 0°C	300max	300max
		Io=0 - 30%	600max	750max
	TEMPERATURE REGULATION[mV]	0 to +70°C	240max	480max
		-25 to +70°C	360max	600max
	DRIIFT[mV]	*5 96max	192max	
START-UP TIME[ms]	750max (ACIN 115V, Io=100%)			
HOLD-UP TIME[ms]	20typ (ACIN 115V, Io=100%)			
OUTPUT VOLTAGE ADJUSTMENT RANGE[V]	22.5 to 26.4	45.0 to 55.2		
OUTPUT VOLTAGE SETTING[V]	24.0±1.0%	48.0±1.0%		
PROTECTION CIRCUIT AND OTHERS	OVERCURRENT PROTECTION	Works over 101% of peak current and recovers automatically		
	OVERVOLTAGE PROTECTION[V]	30.0 to 36.0	57.6 to 67.2	
	REMOTE ON/OFF (RC)	Provided		
	DC_OK LAMP	LED (Green)		
	ALARM LAMP	LED (Red)		
DC_OK CONTACT	Relay contact 30VDC 1A max, 30VAC 0.5A max (resistive load) (Only KHEA)			
ISOLATION	INPUT-OUTPUT	AC3,000V 1minute, Cutoff current = 10mA, DC500V 50MΩ min (At Room Temperature)		
	INPUT-PE	AC2,000V 1minute, Cutoff current = 10mA, DC500V 50MΩ min (At Room Temperature)		
	OUTPUT-PE	AC500V 1minute, Cutoff current = 100mA, DC500V 50MΩ min (At Room Temperature)		
	OUTPUT-RC, DC_OK	AC500V 1minute, Cutoff current = 100mA, DC500V 50MΩ min (At Room Temperature)		
ENVIRONMENT	OPERATING TEMP., HUMID. AND ALTITUDE	-25 to +70°C, 20 - 90%RH (Non condensing), Type tested for -40°C start-up (Refer to "Derating")		
	STORAGE TEMP., HUMID. AND ALTITUDE	-40 to +85°C, 20 - 90%RH (Non condensing)		
	VIBRATION	*8 10 - 55Hz, 19.6m/s ² (2G), 3minutes period, 60 minutes along Z axis (Non operating, mounted on DIN Rail)		
IMPACT	196.1m/s ² (20G), 11ms, once each X, Y and Z axis (Packing state)			
SAFETY AND NOISE REGULATIONS	AGENCY APPROVALS	AC input	UL60950-1, C-UL (CSA60950-1), EN62368-1, UL508, ANSI/ISA12.12.01, ATEX, GL (Only 24V), Complies with DEN-AN	
		DC input	UL60950-1, C-UL (CSA60950-1), EN62368-1	
	CONDUCTED NOISE	Complies with FCC-B, VCCI-B, CISPR22-B, EN55011-B, EN55022-B		
HARMONIC ATTENUATOR	Complies with IEC61000-3-2 (Class A) *6			
OTHERS	CASE SIZE	*7	70×124×117mm (W×H×D) [2.76×4.88×4.61 inches]	
	WEIGHT	1,200g max		
	COOLING METHOD	Convection		

- *1 The value is primary surge. The current of input surge to a built-in EMI/EMC Filter(0.2ms or less)is excluded.
- *2 Refer to 3, instruction manual.
- *3 Please contact us about dynamic load and input response.
- *4 This is the value that measured on measuring board with capacitor of 22 μF and 0.1 μF at 150mm from output terminal.
Measured by 20MHz oscilloscope or Ripple-Noise meter (Equivalent to KEISOKU-GIKEN: RM103).

- *5 Please refer to the instruction manual 1.7.
Drift is the change in DC output for an eight hour period after a half-hour warm-up at 25 C, with the input voltage held constant at the rated input/output.
- *6 Please contact us about another class.
- *7 Case size contains neither the umbo.
- *8 Only as standard mounting orientation (A). Refer to the "Assembling and Installation Method".

- If install other than standard mounting orientation (A), please fix the power supply for withstand the vibration and impact.
- *9 Burst operation at 30% load or less.
- *10 Under low DC input voltage below DC110V, the temperature derating -1C/V or the output power derating -1%/V are required.
- * To meet the specifications. Do not operate over-loaded condition.
- * A sound may occur from power supply at light or peak loading.

Block diagram

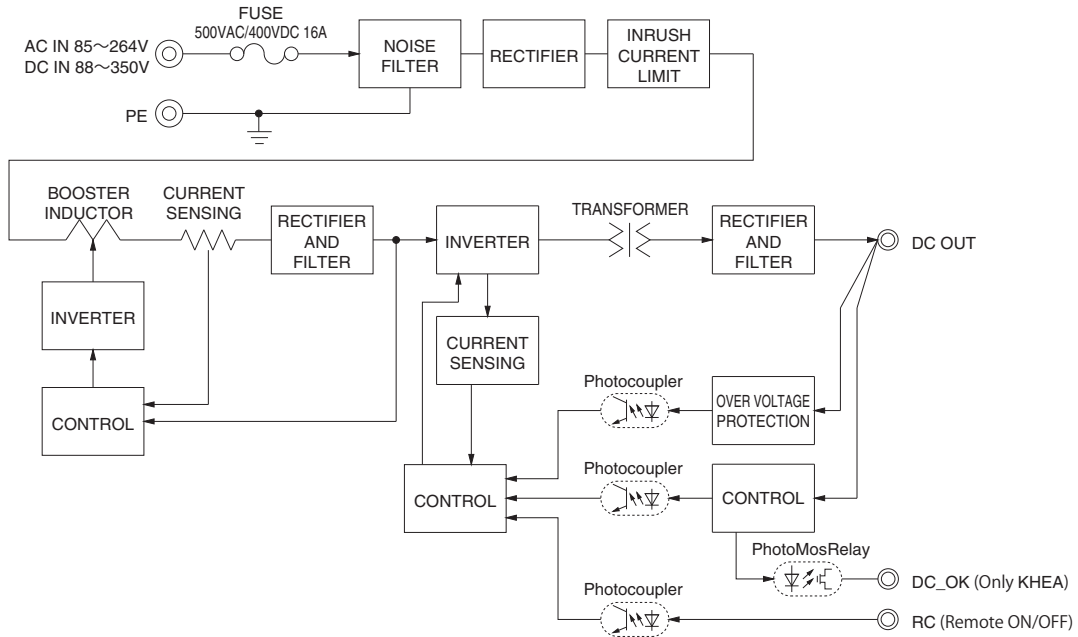

External view

<KHEA480F(Euro Style I/O Terminals)>

<KHNA480F(Barrier Blocks Style I/O Terminals)>

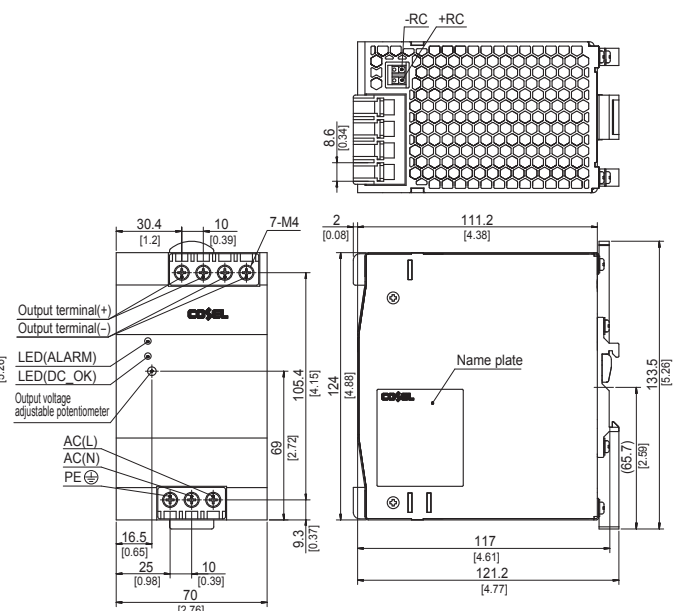
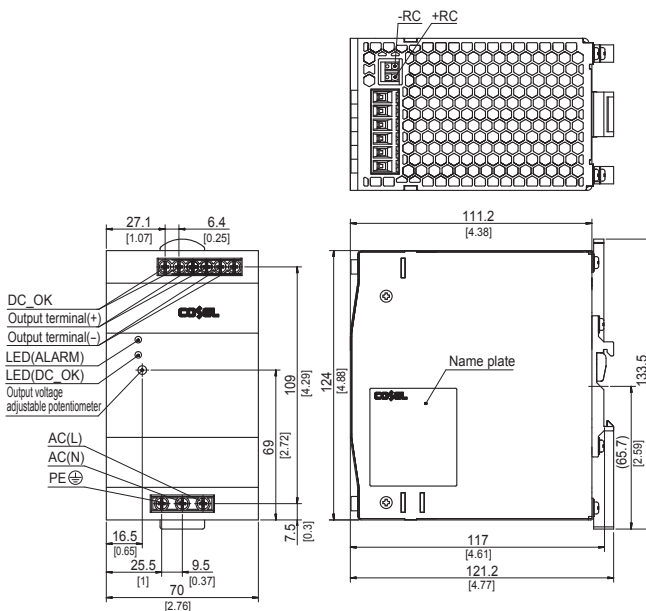

- ※ Tolerance : ±1 [±0.04]
- ※ Weight : 1,200g max
- ※ PCB Material/thickness : FR-4 / 1.6mm [0.06]
- ※ Chassis material : Aluminum
- ※ Case material : Stainless steel
- ※ DIN rail attachment material : Aluminum, Stainless steel, Nylon
- ※ Dimensions in mm, [] = inches
- ※ Screw tightening torque : 1N · m max

- ※ Tolerance : ±1 [±0.04]
- ※ Weight : 1,200g max
- ※ PCB Material/thickness : FR-4 / 1.6mm [0.06]
- ※ Chassis material : Aluminum
- ※ Case material : Stainless steel
- ※ DIN rail attachment material : Aluminum, Stainless steel, Nylon
- ※ Dimensions in mm, [] = inches
- ※ Screw tightening torque : 1.6N · m max

Terminal Blocks

● **KHEA30F**

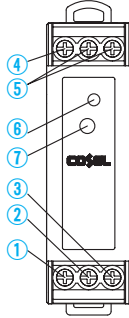

● **KHNA30F**

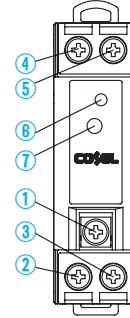

● **KHEA60F**

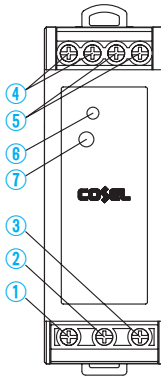

● **KHNA60F**

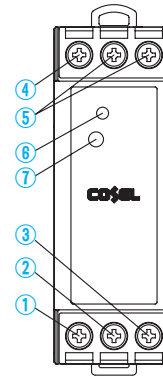

● **KHEA90F**

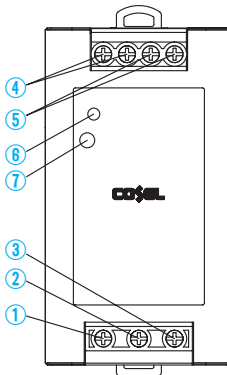

● **KHNA90F**

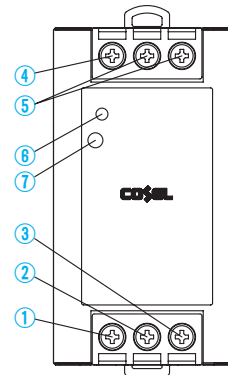

KH

Terminal Number	Terminal Name	Function
①	PE	Protective earth Terminal
②	AC (N)	Input Terminals
③	AC (L)	
④	+VOUT	+Output Terminals
⑤	-VOUT	-Output Terminals
⑥	DC_OK	LED for output voltage confirmation
⑦	TRM	Adjustment of output voltage

Terminal Blocks

● KHEA120F

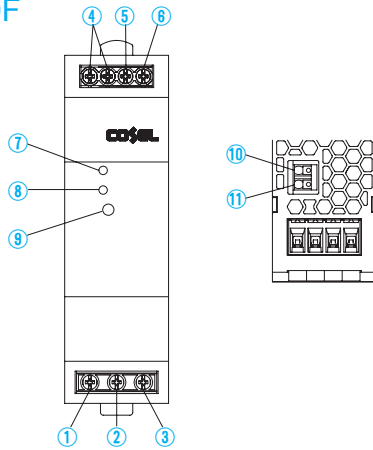

● KHNA120F

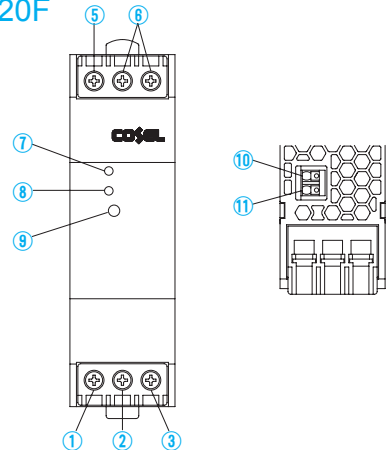

● KHEA240F

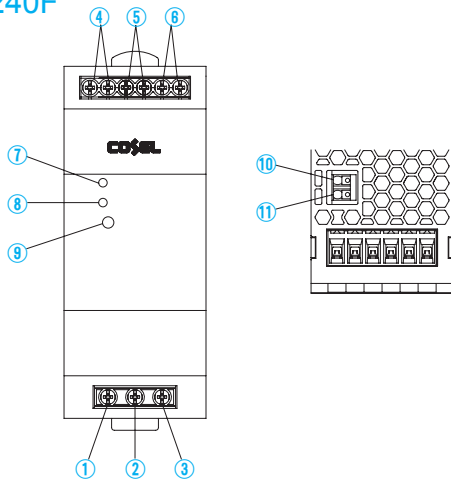

● KHNA240F

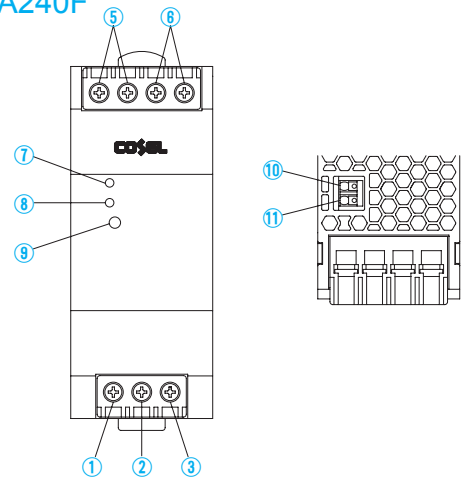

● KHEA480F

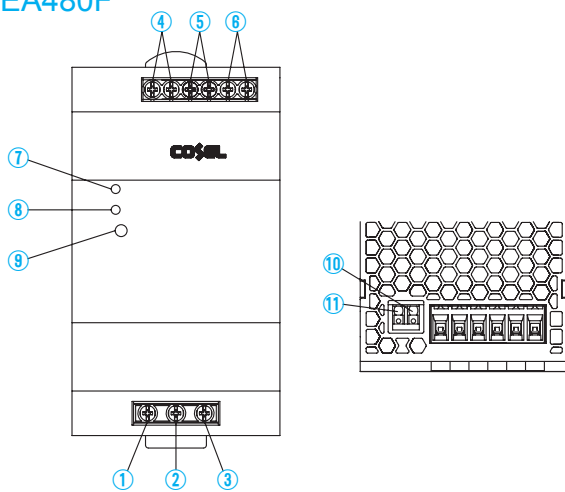

● KHNA480F

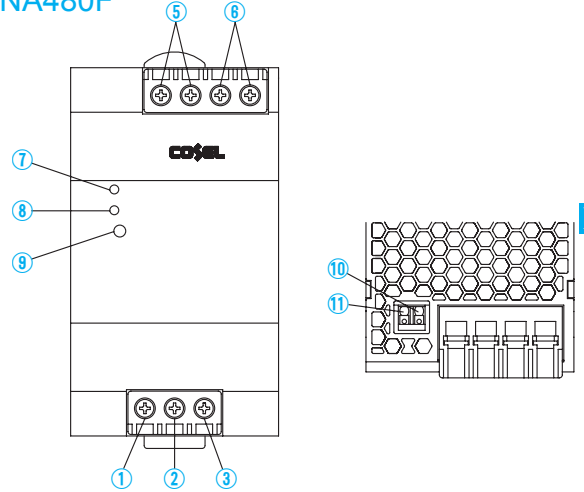

Terminal Number	Terminal Name	Function
①	PE	Protective earth Terminal
②	AC (N)	Input Terminals
③	AC (L)	
④	DC_OK	Output voltage confirmation(relay contact)
⑤	+VOUT	+Output Terminals
⑥	-VOUT	-Output Terminals

Terminal Number	Terminal Name	Function
⑦	ALARM	LED Alarm for lowered output voltage
⑧	DC_OK	LED for output voltage confirmation
⑨	TRM	Adjustment of output voltage
⑩	+RC	Remote ON/OFF Terminals
⑪	-RC	

Assembling and Installation Method

Installation method

- About DIN-Rail Attachment available with DIN EN60715 TH 35 (35×7.5mm or 35×15mm) (Top hat shaped DIN rail)
- Below shows mounting orientation.
If install other than standard mounting orientation (A), please fix the power supply for withstand the impact and vibration.

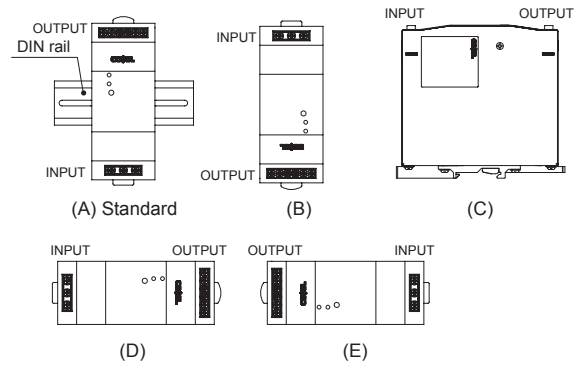

- When you mount a power supply on a DIN rail, have the area marked A catch one side of the rail and push the unit to the direction of B. To remove the power supply from the rail, either push down the area marked C or insert a tool such as driver to the area marked D and pull the unit apart from the rail. When you couldn't remove the unit easily, push down the area marked C while lightly pushing the unit to the direction of E.

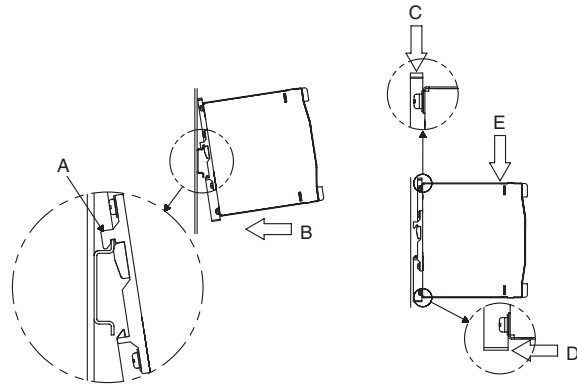

- Shown below the notes about installation clearance of a unit.

● KHEA30F/60F/90F, KHNA30F/60F/90F

- ① Installation clearance at above and below the unit.
Please have clearance of at least 25mm above and below the unit to avoid heat accumulation.
- ② Installation clearance at the side of the unit.
Please have clearance of at least 5mm side the unit to insulating the internal components. However, refer to right figure, if adjacent device of the unit (including power supply) is a heat source.

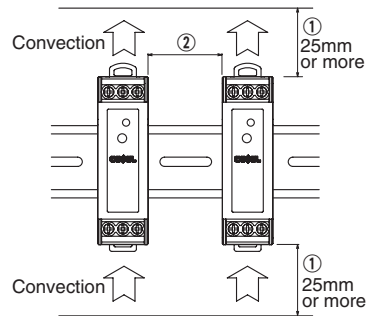

No.	Model	Adjacent device of the unit	
		Non-heat source	Heat source(*)
1	KHEA30F, KHNA30F	5mm or more	15mm or more
2	KHEA60F, KHNA60F	5mm or more	15mm or more
3	KHEA90F, KHNA90F	5mm or more	15mm or more

*Reference value when same power units are adjacent.

Assembling and Installation Method

● **KHEA120F/240F/480F, KHNA120F/240F/480F**

- ① Installation clearance at above and below the unit.
Please have clearance of at least 25mm above and below the unit to avoid heat accumulation.
- ② Installation clearance at the side of the unit.
Please have clearance of at least 15mm side the unit to avoid interfering with heat radiation from housing. However, refer to right figure, if adjacent device of the unit (including power supply) is a heat source.

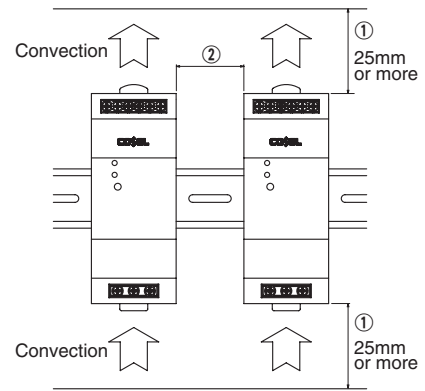

No.	Model	Adjacent device of the unit	
		Non-heat source	Heat source(*)
1	KHEA120F, KHNA120F	15mm or more	
2	KHEA240F, KHNA240F	15mm or more	
3	KHEA480F, KHNA480F	15mm or more	50mm or more

* Reference value when same power units are adjacent.

Derating

Derating curve for input voltage

● **KHEA30F/60F/90F, KHNA30F/60F/90F**

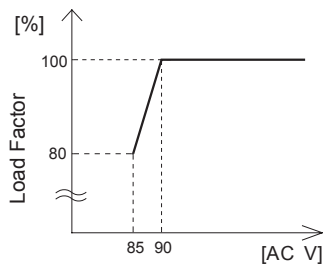

● **KHEA480F, KHNA480F**

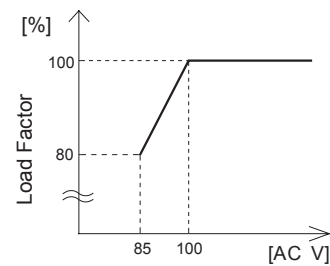

Ambient temperature derating

■ The operative ambient temperature as different by input voltage. Derating curve is shown below.

■ In the hatched area, the specification of Ripple, Ripple Noise is different from other area.

■ Derating Curve (Convection)

■ Refer to instruction manual 4 for Ambient temperature measurement point.

● **KHEA30F, KHNA30F**

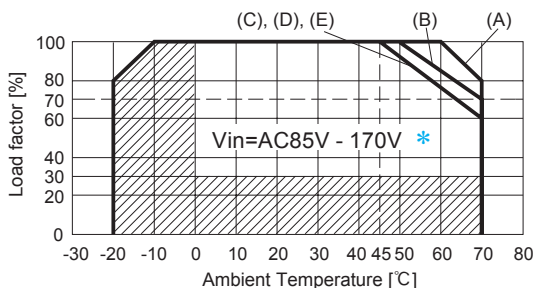

* Derating curve depend on input voltage is required.

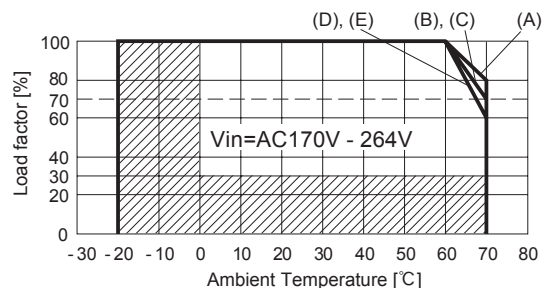

Derating

● KHEA60F, KHNA60F

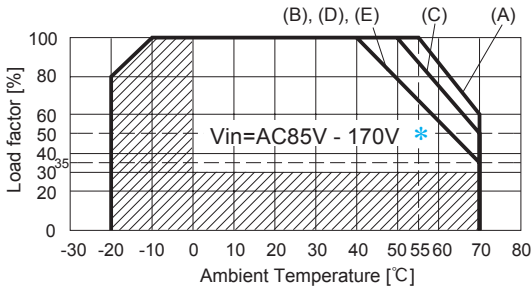

* Derating curve depend on input voltage is required.

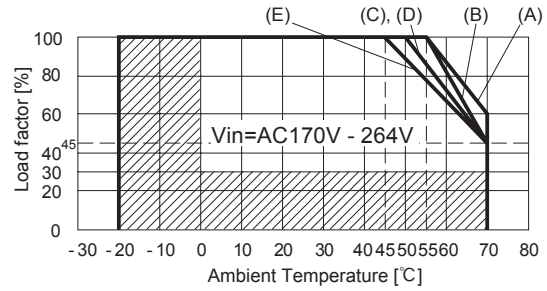

● KHEA90F, KHNA90F

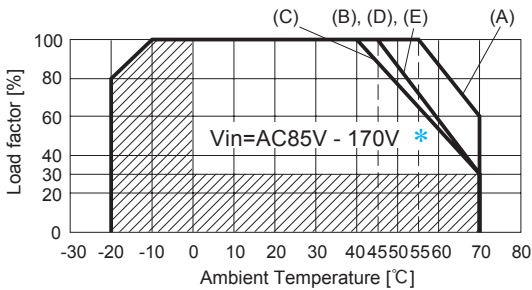

* Derating curve depend on input voltage is required.

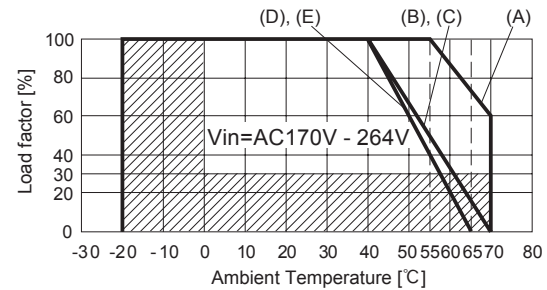

● KHEA120F, KHNA120F

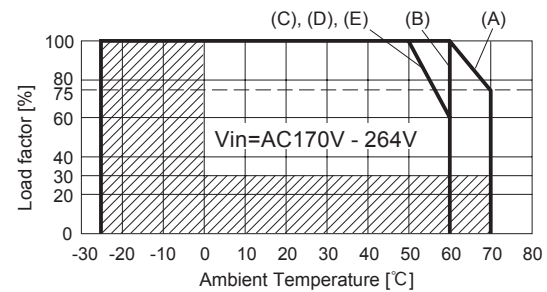
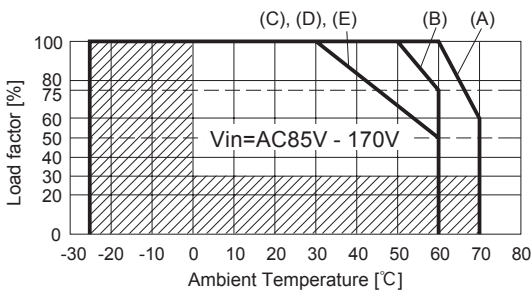

KH

● KHEA240F, KHNA240F

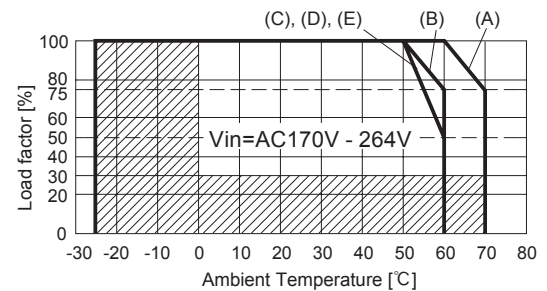
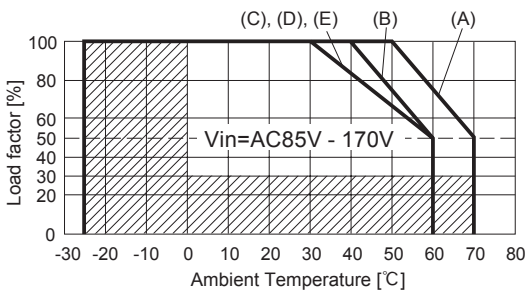

Derating

● KHEA480F, KHNA480F

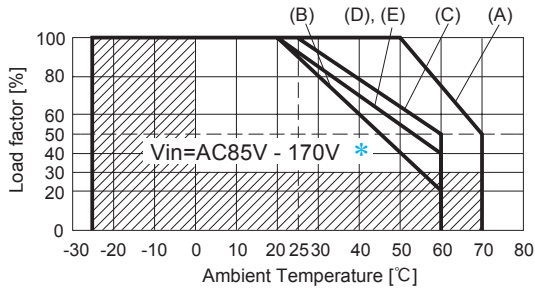

* Derating curve depend on input voltage is required.

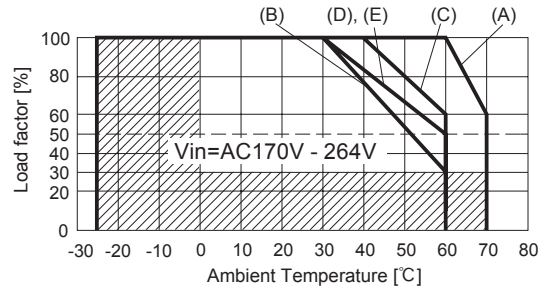

■ Derating Curve (Forced air)

■ Use the temperature measurement point as shown in instruction manual 4. Please use at the temperature dose not exceed the values in instruction manual 4.

● KHEA30F/60F/90F, KHNA30F/60F/90F

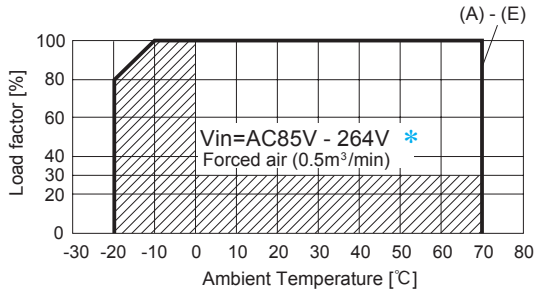

* Derating curve depend on input voltage is required.

● KHEA120F/240F, KHNA120F/240F

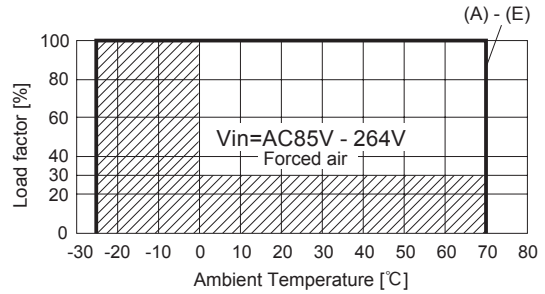

● KHEA480F, KHNA480F

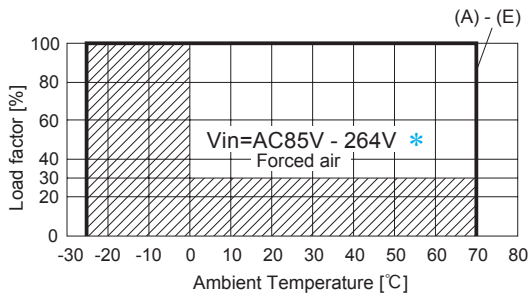

* Derating curve depend on input voltage is required.

Instruction Manual

◆ It is necessary to read the “Instruction Manual” and “Before using our product” before you use our product.

Instruction Manual <https://www.cosel.co.jp/redirect/catalog/en/KH/>
 Before using our product <https://en.cosel.co.jp/technical/caution/index.html>



Basic Characteristics Data

Model	Circuit method	Switching frequency *2 [kHz]	Input current [A] *1	Rated input fuse	Inrush current protection circuit	PCB/Pattern			Series/Parallel operation availability	
						Material	Single sided	Double sided	Series operation	Parallel operation
KHEA30F KHNA30F	Flyback converter	50 - 200	0.55	500VAC/400VDC 3.15A	Thermistor	FR-4		Yes	Yes	No
KHEA60F KHNA60F	Flyback converter	50 - 200	1.10	500VAC/400VDC 3.15A	Thermistor	FR-4		Yes	Yes	No
KHEA90F KHNA90F	Active filter Flyback converter	20 - 500 50 - 200	0.95	500VAC/400VDC 3.15A	Thermistor	FR-4		Yes	Yes	No
KHEA120F KHNA120F	Active filter LLC resonant converter	60 - 550 45 - 350	1.2	500VAC/400VDC 5A	Thermistor	FR-4		Yes	Yes	No
KHEA240F KHNA240F	Active filter LLC resonant converter	60 - 550 45 - 350	2.3	500VAC/400VDC 8A	SCR	FR-4		Yes	Yes	No
KHEA480F KHNA480F	Active filter LLC resonant converter	60 - 150 45 - 350	4.6	500VAC/400VDC 16A	Relay	FR-4		Yes	Yes	No

*1 The value of input current is at ACIN 115V and 100%.

*2 Burst operation at light loading, frequency is change by use condition.
Please contact us about detail.

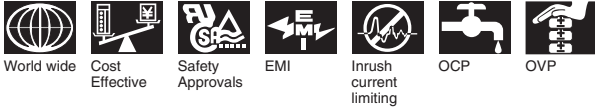

WDA-series



Feature

For DIN (35mm) Rail Products
Built in overcurrent protection, overvoltage protection circuits
Economical design

Safety agency approvals

UL62368-1
C-UL (equivalent to CAN/CSA-C22.2 No.62368-1)
EN62368-1

CE marking

Low Voltage Directive
RoHS Directive

5-year warranty (See Instruction Manual)

EMI

Complies with CISPR32-B, EN55032-B and EN55011-B

EMS Compliance : EN61204-3, EN61000-6-2

EN61000-4-2
EN61000-4-3
EN61000-4-4
EN61000-4-5
EN61000-4-6
EN61000-4-8
EN61000-4-11

WDA

WDA30F

① **WD** ② **A** ③ **30** ④ **F** ⑤ **-□** ⑥ **-□**

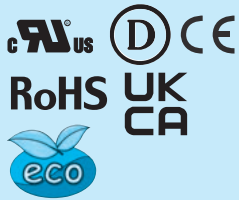

- ① Series name
- ② Single output
- ③ Output wattage
- ④ Universal input
- ⑤ Output voltage
- ⑥ Option : *5
C : With Coating

*Make sure necessary tests will be carried out on your end equipment with the power supply installed in accordance with any required EMC/EMI regulations.

MODEL	WDA30F-5	WDA30F-12	WDA30F-24	WDA30F-48
MAX OUTPUT WATTAGE[W]	30	30	31.2	33.6
DC OUTPUT	5V6A	12V2.5A	24V1.3A	48V0.7A

SPECIFICATIONS

	MODEL	WDA30F-5	WDA30F-12	WDA30F-24	WDA30F-48	
INPUT	VOLTAGE[V]	AC85 - 264 1φ				
	CURRENT[A]	ACIN 115V	0.6			
		ACIN 230V	0.3			
	FREQUENCY[Hz]	50/60 (47-63)				
	EFFICIENCY[%]	ACIN 115V	80typ	85typ	86typ	87typ
		ACIN 230V	82typ	86typ	87typ	88typ
	INRUSH CURRENT[A]	ACIN 115V	20typ Ta=25°C (at cold start)			
ACIN 230V		40typ Ta=25°C (at cold start)				
LEAKAGE CURRENT[mA]	ACIN115V	0.25max				
	ACIN240V	0.5max				
OUTPUT	VOLTAGE[V]	5	12	24	48	
	CURRENT[A]	6	2.5	1.3	0.7	
	WATTAGE[W]	30	30	31.2	33.6	
	LINE REGULATION[mV] *1	50max	120max	240max	480max	
	LOAD REGULATION[mV] *1	50max	120max	240max	480max	
	RIPPLE NOISE [mVp-p] *2 Io=100%	150(Bandwidth 20MHz)				
	TEMPERATURE REGULATION[mV] 0~+50°C	100max	180max	360max	720max	
	START-UP TIME[ms]	ACIN 115V	100typ			
		ACIN 230V	100typ			
	HOLD-UP TIME[ms]	ACIN 115V	10typ			
		ACIN 230V	20typ			
OUTPUT VOLTAGE ADJUSTMENT RANGE[V]	4.50 to 5.50	10.8 to 13.2	21.6 to 26.4	43.2 to 52.8		
OUTPUT VOLTAGE SETTING[V]	4.90 to 5.30	11.75 to 12.25	23.5 to 24.5	47.0 to 49.0		
PROTECTION CIRCUIT AND OTHERS	OVERCURRENT PROTECTION [A]	Works over 105% of rating and recovers automatically				
	OVERVOLTAGE PROTECTION[V]	5.75 to 7.00	13.8 to 16.8	27.6 to 33.6	54.0 to 67.2	
	OPERATING INDICATION	LED (Green)				
ISOLATION	INPUT-OUTPUT	AC3,000V 1minute, Cutoff current = 10mA, DC500V 50MΩ min (At Room Temperature)				
	INPUT-FG	AC2,000V 1minute, Cutoff current = 10mA, DC500V 50MΩ min (At Room Temperature)				
	OUTPUT-FG	AC500V 1minute, Cutoff current = 100mA, DC500V 50MΩ min (At Room Temperature)				
ENVIRONMENT	OPERATING TEMP.,HUMID.*3	-20 to +70°C, 20 - 90%RH (Non condensing)				
	STORAGE TEMP.,HUMID.	-30 to +85°C, 20 - 90%RH (Non condensing)				
	VIBRATION	10 - 55Hz, 19.6m/s ² (2G) , 3minutes period, 60minutes each along Z axis (Non operating.mounted on DIN Rail)				
	IMPACT	196.1m/s ² (20G) , 11ms, once each X, Y and Z axis (Packing state)				
SAFETY AND EMC	AGENCY APPROVALS	UL62368-1, C-UL (equivalent to CAN/CSA-C22.2 No.62368-1) , EN62368-1				
	EMC EMISSION	Complies with CISPR32-B, EN55032-B, EN55011-B				
	EMC IMMUNITY	Complies with EN61000-4-2, 3, 4, 5, 6, 8, 11				
OTHERS	HARMONIC ATTENUATOR	Complies with IEC61000-3-2 (Class A) No built-in active PFC				
	CASE SIZE/WEIGHT	32x90x90mm (WxHxD) [1.26x3.54x3.54 inches] / 200g max				
	COOLING METHOD	Convection				
WARRANTY	WARRANTY	*4	5 years (subject to the operating conditions)			

*1 Consult us about dynamic load and input response. Measure the output voltage by using the average mode of the tester to deal with the burst operation at low (Io=0~20%typ) load.

*2 This is the result of measurement of the testing board with capacitors of 47μF and 0.1μF placed at 150 mm from the output terminals by a 20MHz oscilloscope or a ripple-noise meter equivalent to Keisoku-GikenRM104.

When the load factor is low (Io=0~20%Atp), the switching power loss is reduced by burst operation, which will cause ripple noise to go beyond the specifications.

*3 Output power derating is required. Refer to "Derating"

*4 Consult us about details.

*5 The listed options may affect the published standard specifications. Please contact us for detailed product specifications and safety approvals.

* All parameters not specially mentioned are measured at ACIN 230V, rated load and 25°C of ambient temperature.

* Do not use the power supply in overcurrent conditions or in unspecified input voltage ranges. Otherwise the internal components may be damaged.

* Parallel operation is not possible with this model.

* Acoustic noise may be heard from the power supply when used for pulse load.

External view

<WDA30F>

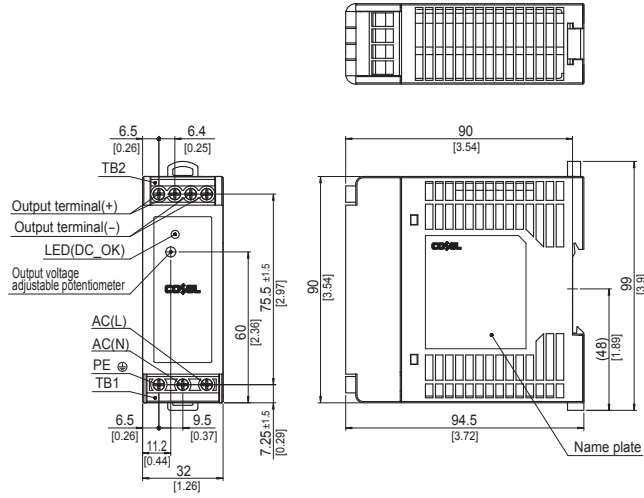

- ※ Tolerance : ±1 [±0.04]
- ※ Weight : 200g max
- ※ Chassis · Case material : PBT
- ※ Din rail attachment material : PC/ABS
- ※ Dimensions in mm, [] = inches
- ※ Screw tightening torque : 1N · m max

Derating Curve

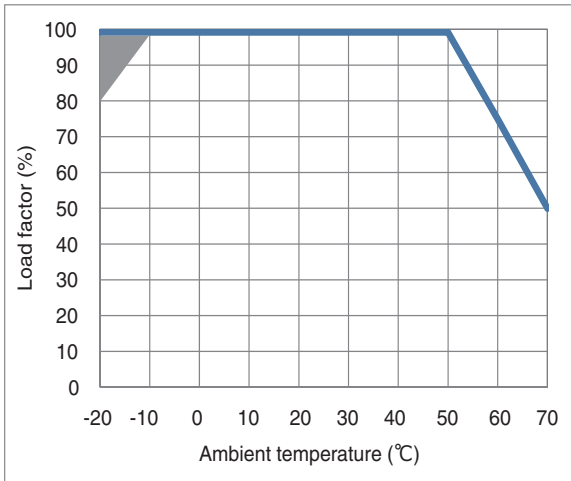

*In the shaded area, it may take several seconds to determine the output voltage during cold start, but it can be used without any problems.

Fig.1 Derating curve depending on ambient temperature

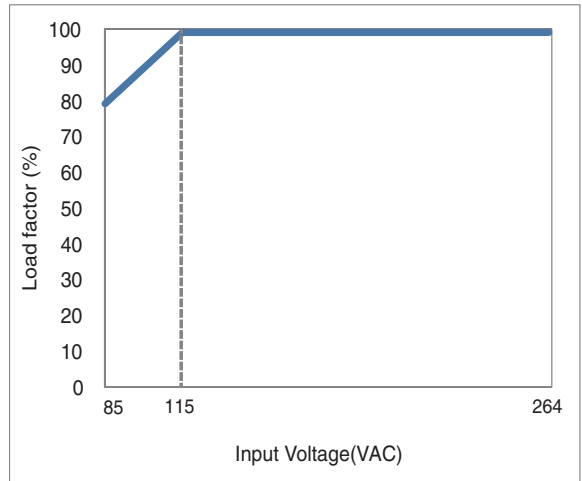

Fig.2 Derating curve depending on input voltage

WDA60F

① **WD** ② **A** ③ **60** ④ **F** ⑤ **-** □ ⑥ **-** □



- ① Series name
- ② Single output
- ③ Output wattage
- ④ Universal input
- ⑤ Output voltage
- ⑥ Option : *5
C : With Coating

*Make sure necessary tests will be carried out on your end equipment with the power supply installed in accordance with any required EMC/EMI regulations.

MODEL	WDA60F-12	WDA60F-24	WDA60F-48
MAX OUTPUT WATTAGE[W]	60	60	62.4
DC OUTPUT	12V 5A	24V 2.5A	48V 1.3A

SPECIFICATIONS

	MODEL	WDA60F-12	WDA60F-24	WDA60F-48	
INPUT	VOLTAGE[V]	AC85 - 264 1φ			
	CURRENT[A]	ACIN 115V	1.2		
		ACIN 230V	0.6		
	FREQUENCY[Hz]	50/60 (47-63)			
	EFFICIENCY[%]	ACIN 115V	84typ	86typ	87typ
		ACIN 230V	86typ	88typ	89typ
	INRUSH CURRENT[A]	ACIN 115V	20typ Ta=25°C (at cold start)		
ACIN 230V		40typ Ta=25°C (at cold start)			
LEAKAGE CURRENT[mA]	ACIN 115V	0.25max			
	ACIN240V	0.5max			
OUTPUT	VOLTAGE[V]	12	24	48	
	CURRENT[A]	5	2.5	1.3	
	WATTAGE[W]	60	60	62.4	
	LINE REGULATION[mV] *1	120max	240max	480max	
	LOAD REGULATION[mV] *1	120max	240max	480max	
	RIPPLE NOISE [mVp-p] *2	Io=100% 150max (Bandwidth 20MHz)			
	TEMPERATURE REGULATION[mV]	0~+50°C	180max	360max	
	START-UP TIME[ms]	ACIN 115V	100typ		
		ACIN 230V	100typ		
	HOLD-UP TIME[ms]	ACIN 115V	10typ		
ACIN 230V		20typ			
OUTPUT VOLTAGE ADJUSTMENT RANGE[V]	10.8 to 13.2	21.6 to 26.4	43.2 to 52.8		
OUTPUT VOLTAGE SETTING[V]	11.75 to 12.25	23.5 to 24.5	47.0 to 49.0		
PROTECTION CIRCUIT AND OTHERS	OVERCURRENT PROTECTION [A]	Works over 105% of rating and recovers automatically			
	OVERVOLTAGE PROTECTION[V]	13.8 to 16.8	27.6 to 33.6	54.0 to 67.2	
	OPERATING INDICATION	LED (Green)			
ISOLATION	INPUT-OUTPUT	AC3,000V 1minute, Cutoff current = 10mA, DC500V 50MΩ min (At Room Temperature)			
	INPUT-FG	AC2,000V 1minute, Cutoff current = 10mA, DC500V 50MΩ min (At Room Temperature)			
	OUTPUT-FG	AC500V 1minute, Cutoff current = 100mA, DC500V 50MΩ min (At Room Temperature)			
ENVIRONMENT	OPERATING TEMP., HUMID. *3	-20 to +70°C, 20-90%RH (Non condensing)			
	STORAGE TEMP., HUMID.	-30 to +85°C, 20-90%RH (Non condensing)			
	VIBRATION	10-55Hz, 19.6m/s ² (2G) , 3minutes period, 60minutes each along Z axis (Non operating.mounted on DIN Rail)			
	IMPACT	196.1m/s ² (20G) , 11ms, once each X, Y and Z axis (Packing state)			
SAFETY AND EMC	AGENCY APPROVALS	UL62368-1, C-UL (equivalent to CAN/CSA-C22.2 No.62368-1) , EN62368-1			
	EMC EMISSION	Complies with CISPR32-B, EN55032-B, EN55011-B			
	EMC IMMUNITY	Complies with EN61000-4-2, 3, 4, 5, 6, 8, 11			
OTHERS	HARMONIC ATTENUATOR	Complies with IEC61000-3-2 (Class A) No built-in active PFC			
	CASE SIZE/WEIGHT	32X90X90mm (WXHXD) [1.26X3.54X3.54 inches] / 250g max			
	COOLING METHOD	Convection			
WARRANTY	WARRANTY	*4	5 years (subject to the operating conditions)		

*1 Consult us about dynamic load and input response. Measure the output voltage by using the average mode of the tester to deal with the burst operation at low (Io=0~20%typ) load.

*2 This is the result of measurement of the testing board with capacitors of 47μF and 0.1μF placed at 150 mm from the output terminals by a 20MHz oscilloscope or a ripple-noise meter equivalent to Keisoku-GikenRM104.

When the load factor is low (Io=0~20%Atyp), the switching power loss is reduced by burst operation, which will cause ripple noise to go beyond the specifications.

*3 Output power derating is required. Refer to "Derating"

*4 Consult us about details.

*5 The listed options may affect the published standard specifications. Please contact us for detailed product specifications and safety approvals.

* All parameters not specially mentioned are measured at ACIN 230V, rated load and 25°C of ambient temperature.

* Do not use the power supply in overcurrent conditions or in unspecified input voltage ranges. Otherwise the internal components may be damaged.

* Parallel operation is not possible with this model.

* Acoustic noise may be heard from the power supply when used for pulse load.

External view

<WDA60F>

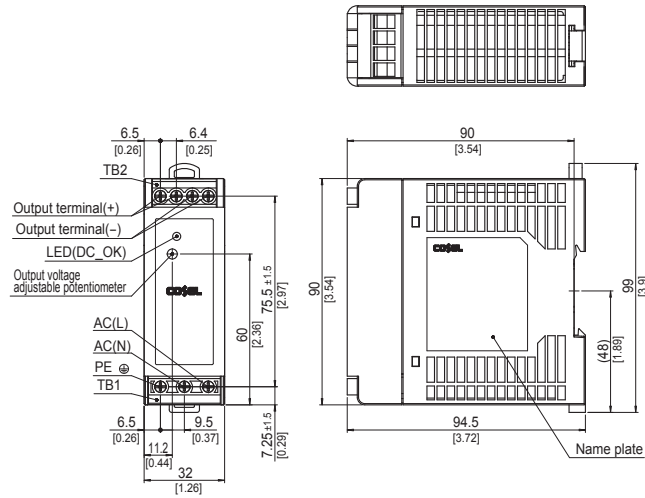

- ※ Tolerance : ±1 [±0.04]
- ※ Weight : 250g max
- ※ Chassis - Case material : PBT
- ※ Din rail attachment material : PC/ABS
- ※ Dimensions in mm, [] = inches
- ※ Screw tightening torque : 1N · m max

Derating Curve

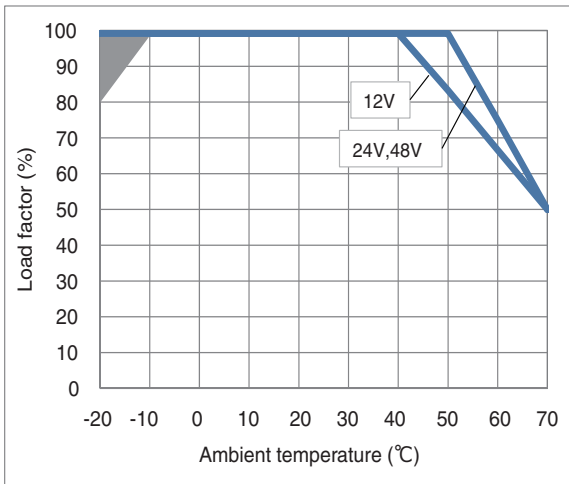

*In the shaded area, it may take several seconds to determine the output voltage during cold start, but it can be used without any problems.

Fig.1 Derating curve depending on ambient temperature

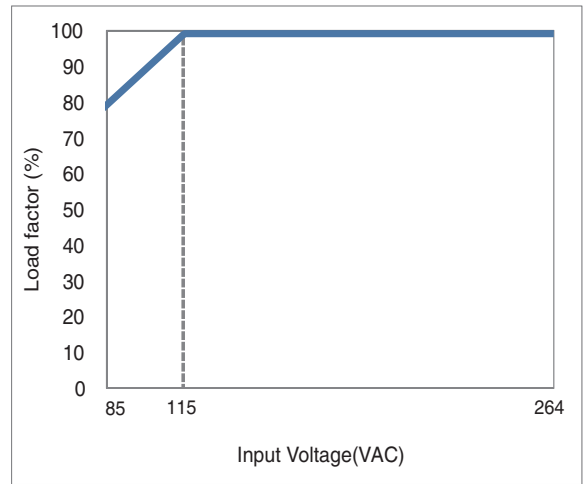
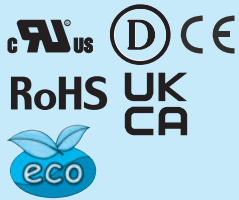

Fig.2 Derating curve depending on input voltage

WDA

WDA90F

① **WD** ② **A** ③ **90** ④ **F** ⑤ **-□** ⑥ **-□**



- ① Series name
- ② Single output
- ③ Output wattage
- ④ Input voltage selectable by switch
- ⑤ Output voltage
- ⑥ Option : *5
C : With Coating

*Make sure necessary tests will be carried out on your end equipment with the power supply installed in accordance with any required EMC/EMI regulations.

MODEL	WDA90F-12	WDA90F-24	WDA90F-48
MAX OUTPUT WATTAGE[W]	90	91.2	91.2
DC OUTPUT	12V 7.5A	24V 3.8A	48V 1.9A

SPECIFICATIONS

	MODEL	WDA90F-12	WDA90F-24	WDA90F-48	
INPUT	VOLTAGE[V]	AC85 - 264 1φ			
	CURRENT[A]	ACIN 115V	1.8		
		ACIN 230V	0.9		
	FREQUENCY[Hz]	50/60 (47-63)			
	EFFICIENCY[%]	ACIN 115V	84	87	88
		ACIN 230V	86	89	90
	INRUSH CURRENT[A]	ACIN 115V	20typ Ta=25°C (at cold start)		
ACIN 230V		40typ Ta=25°C (at cold start)			
LEAKAGE CURRENT[mA]	ACIN 115V	0.4max			
	ACIN 240V	0.75max			
OUTPUT	VOLTAGE[V]	12	24	48	
	CURRENT[A]	7.5	3.8	1.9	
	WATTAGE[W]	90	91.2	91.2	
	LINE REGULATION[mV] *1	120max	240max	480max	
	LOAD REGULATION[mV] *1	120max	240max	480max	
	RIPPLE NOISE [mVp-p] *2	150max (Bandwidth 20MHz)			
	TEMPERATURE REGULATION[mV]	0~+50°C	180max	360max	720max
	START-UP TIME[ms]	ACIN 115V	100typ		
		ACIN 230V	10typ		
	HOLD-UP TIME[ms]	ACIN 115V	10typ		
ACIN 230V		20typ			
OUTPUT VOLTAGE ADJUSTMENT RANGE[V]	10.8 to 13.2		21.6 to 26.4	43.2 to 52.8	
OUTPUT VOLTAGE SETTING[V]	11.75 to 12.25		23.5 to 24.5	47.0 to 49.0	
PROTECTION CIRCUIT AND OTHERS	OVERCURRENT PROTECTION [A]	Works over 105% of rating and recovers automatically			
	OVERVOLTAGE PROTECTION[V]	13.8 to 16.8	27.6 to 33.6	54.0 to 67.2	
	OPERATING INDICATION	LED (Green)			
ISOLATION	INPUT-OUTPUT	AC3,000V 1minute, Cutoff current = 10mA, DC500V 50MΩ min (At Room Temperature)			
	INPUT-FG	AC2,000V 1minute, Cutoff current = 10mA, DC500V 50MΩ min (At Room Temperature)			
	OUTPUT-FG	AC500V 1minute, Cutoff current = 100mA, DC500V 50MΩ min (At Room Temperature)			
ENVIRONMENT	OPERATING TEMP., HUMID. *3	-20 to +70°C, 20-90%RH (Non condensing)			
	STORAGE TEMP., HUMID.	-30 to +85°C, 20-90%RH (Non condensing)			
	VIBRATION	10 - 55Hz, 19.6m/s ² (2G) , 3minutes period, 60minutes each along Z axis (Non operating, mounted on DIN Rail)			
	IMPACT	196.1m/s ² (20G) , 11ms, once each X, Y and Z axis (Packing state)			
SAFETY AND EMC	AGENCY APPROVALS	UL62368-1, C-UL (equivalent to CAN/CSA-C22.2 No.62368-1) , EN62368-1			
	EMC EMISSION	Complies with CISPR32-B, EN55032-B, EN55011-B			
	EMC IMMUNITY	Complies with EN61000-4-2, 3, 4, 5, 6, 8, 11			
OTHERS	HARMONIC ATTENUATOR	Complies with IEC61000-3-2 (Class A) No built-in active PFC			
	CASE SIZE/WEIGHT	50X90X90mm (W X H X D) [1.97X3.54X3.54 inches] / 350g max			
	COOLING METHOD	Convection			
WARRANTY	WARRANTY	*4	5 years (subject to the operating conditions)		

*1 Consult us about dynamic load and input response. Measure the output voltage by using the average mode of the tester to deal with the burst operation at low (Io=0~20%typ) load.
 *2 This is the result of measurement of the testing board with capacitors of 47μF and 0.1μF placed at 150 mm from the output terminals by a 20MHz oscilloscope or a ripple-noise meter equivalent to Keisoku-GikenRM104.
 When the load factor is low (Io=0~20%Atyp), the switching power loss is reduced by burst operation, which will cause ripple noise to go beyond the specifications.
 *3 Output power derating is required. Refer to "Derating"
 *4 Consult us about details.

*5 The listed options may affect the published standard specifications. Please contact us for detailed product specifications and safety approvals.
 * All parameters not specially mentioned are measured at ACIN 230V, rated load and 25°C of ambient temperature.
 * Do not use the power supply in overcurrent conditions or in unspecified input voltage ranges. Otherwise the internal components may be damaged.
 * Parallel operation is not possible with this model.
 * Acoustic noise may be heard from the power supply when used for pulse load.

External view

<WDA90F>

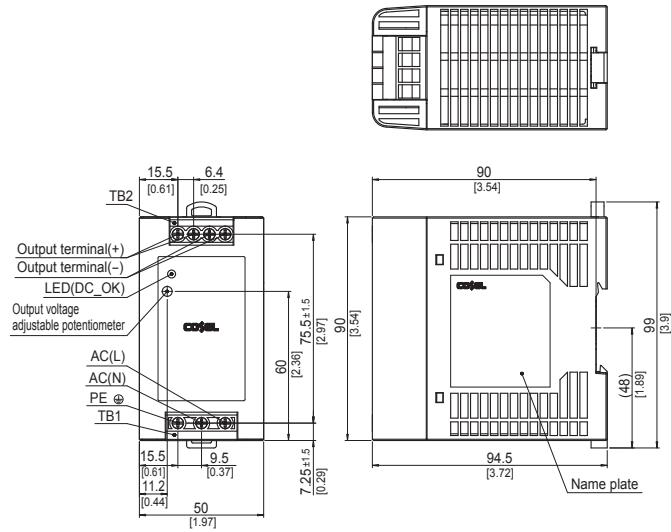

- ※ Tolerance : ± 1 [± 0.04]
- ※ Weight : 350g max
- ※ Chassis · Case material : PBT
- ※ Din rail attachment material : PC/ABS
- ※ Dimensions in mm, [] = inches
- ※ Screw tightening torque : 1N · m max

Derating Curve

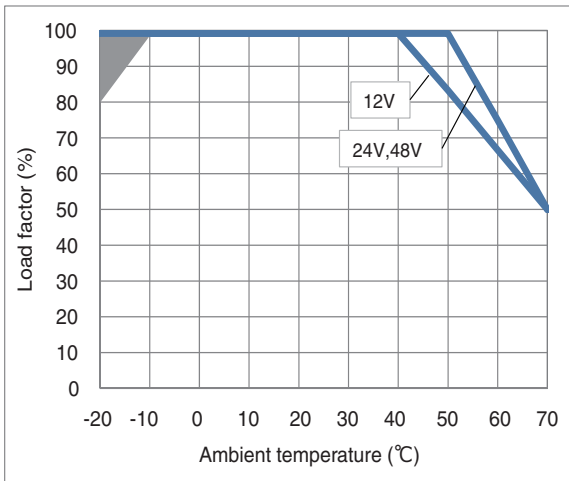

*In the shaded area, it may take several seconds to determine the output voltage during cold start, but it can be used without any problems.

Fig.1 Derating curve depending on ambient temperature

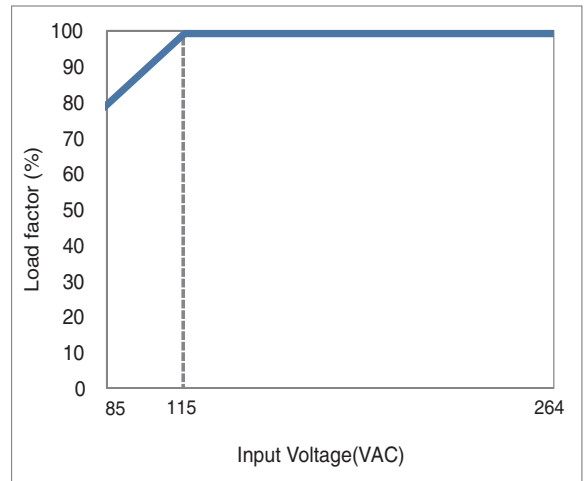
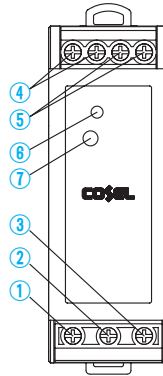

Fig.2 Derating curve depending on input voltage

WDA

Terminal Blocks

●WDA30F



●WDA60F

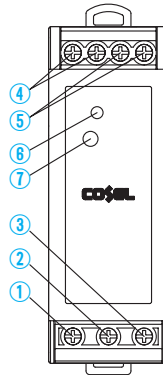

●WDA90F

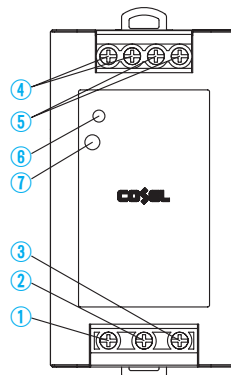

WDA

Terminal Number	Terminal Name	Function
①	PE	Protective earth Terminal
②	AC (N)	Input Terminals
③	AC (L)	
④	+VOUT	+Output Terminals
⑤	-VOUT	-Output Terminals
⑥	DC_OK	LED for output voltage confirmation
⑦	TRM	Adjustment of output voltage

Assembling and Installation Method

Installation method

- About DIN-Rail Attachment available with DIN EN60715 TH 35 (35×7.5mm or 35×15mm) (Top hat shaped DIN rail)
- Below shows mounting orientation.
If install other than standard mounting orientation (A), please fix the power supply for withstand the impact and vibration.

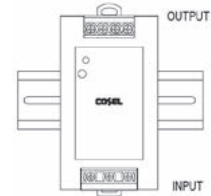

(A) Standard

- When you mount a power supply on a DIN rail, have the area marked A catch one side of the rail and push the unit to the direction of B. To remove the power supply from the rail, either push down the area marked C or insert a tool such as driver to the area marked D and pull the unit apart from the rail. When you couldn't remove the unit easily, push down the area marked C while lightly pushing the unit to the direction of E.

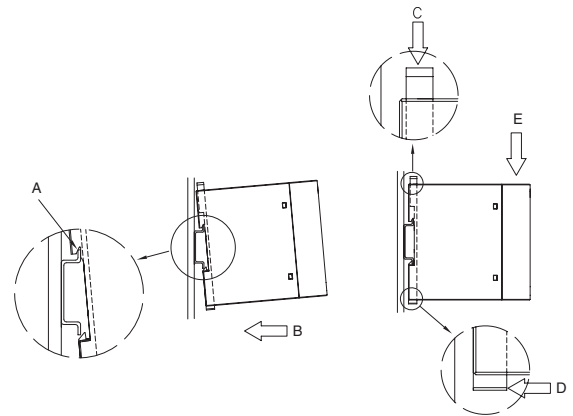

- Shown below the notes about installation clearance of a unit.

- ① Installation clearance at above and below the unit.
Please have clearance of at least 25mm above and below the unit to avoid heat accumulation.
- ② Installation clearance at the side of the unit.
Please have clearance of at least 5mm side the unit to insulating the internal components. However, refer to right figure, if adjacent device of the unit (including power supply) is a heat source.

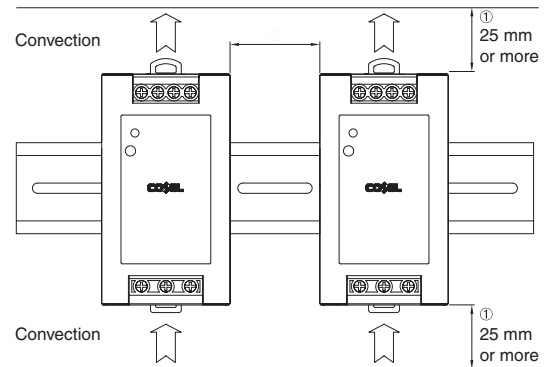

No.	Model	Adjacent device of the unit	
		Non-heat source	Heat source(*)
1	WDA30F/60F/90F	5mm or more	15mm or more

WDA

* Reference value when same power units are adjacent.

Instruction Manual

◆ It is necessary to read the "Instruction Manual" and "Before using our product" before you use our product.

Instruction Manual <https://en.cosel.co.jp/product/powersupply/WDA/>
 Before using our product <https://en.cosel.co.jp/technical/caution/index.html>

WDA



NOTICE



Basic Characteristics Data

Model	Circuit method	Switching frequency [kHz]	Input current [A]	Rated input fuse	Inrush current protection circuit	PCB/Pattern			Parallel operation
						Material	Single sided	Double sided	
WDA30F	Flyback converter	50 to 120	0.6	250V 2.5A	Thermistor	CEM-3/FR4	Yes	Yes	No
WDA60F	Flyback converter	50 to 120	1.2	250V 2.5A	Thermistor	CEM-3/FR4	Yes	Yes	No
WDA90F	Flyback converter	50 to 120	1.8	250V 3.15A	Thermistor	CEM-3/FR4	Yes	Yes	No

- * The value of input current is at ACIN 115V and 100%.
- * Burst operation at light loading, frequency is change by use condition. Please contact us about detail.

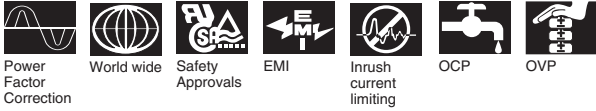

KL-series



Feature

For DIN (35mm) rail products
Wide operating ambient temperature range
I/O terminal has 2 types, Euro Style and Barrier Blocks Style
Built in overcurrent protection, overvoltage protection circuits
Complies with SEMI F-47 (refer to Instruction Manual 1.1)

Safety agency approvals

UL60950-1, UL508, C-UL (CSA60950-1), EN62368-1
Complies with DEN-AN

5-year warranty (refer to Instruction Manual)

CE marking

Low Voltage Directive
RoHS Directive

UKCA marking

Electrical Equipment Safety Regulations
RoHS Regulations

EMI

Complies with FCC-B, CISPR22-B, EN55011-B, EN55022-B, VCCI-B

EMS Compliance : EN61204-3, EN61000-6-2

EN61000-4-2
EN61000-4-3
EN61000-4-4
EN61000-4-5
EN61000-4-6
EN61000-4-8
EN61000-4-11

KLEA/KLNA120F

KL A 120 F - -

① ② ③ ④ ⑤ ⑥



Example recommended EMI/EMC filter
NAC-04-472-D



High voltage pulse noise type : NAP series
Low leakage current type : NAM series
*A higher current rating EMI/EMC filter may be recommended in view of the other devices that could be connected in parallel with the power supply.

- ① Series name
KLE : Euro Style I/O Terminals
KLN : Barrier Blocks Style I/O Terminals
- ② Single output
- ③ Output wattage
- ④ Universal input
- ⑤ Output voltage
- ⑥ Option
C : with Coating
N2 : Screw mounting

*Make sure necessary tests will be carried out on your end equipment with the power supply installed in accordance with any required EMC/EMI regulations.

MODEL	KLEA/KLNA120F-24	KLEA/KLNA120F-48
MAX OUTPUT WATTAGE[W]	120	120
DC OUTPUT	24V 5A	48V 2.5A

SPECIFICATIONS

	MODEL	KLEA/KLNA120F-24	KLEA/KLNA120F-48	
INPUT	VOLTAGE[V]	AC85 - 264 1 φ (Refer to "Derating") *9		
	CURRENT[A]	ACIN 115V	1.2typ	
		ACIN 230V	0.6typ	
	FREQUENCY[Hz]	50 / 60 (45 - 66)		
	EFFICIENCY[%]	ACIN 115V	86.5typ	
		ACIN 230V	88.0typ	
	POWER FACTOR	ACIN 115V	0.98typ	
		ACIN 230V	0.90typ	
INRUSH CURRENT[A]	ACIN 115V	20typ (Io=100%)(at cold start Ta=25°C)		
	*1 ACIN 230V	40typ (Io=100%)(at cold start Ta=25°C)		
LEAKAGE CURRENT[ma]	0.45 / 0.75max (ACIN 100V / 240V 60Hz, Io=100%, According to IEC62368-1 and DEN-AN)			
OUTPUT	VOLTAGE[V]	24	48	
	CURRENT[A]	5	2.5	
	LINE REGULATION[mV] *2	96max (Io=30-100%) *8	192max (Io=30-100%) *8	
	LOAD REGULATION[mV] *2	150max (Io=30-100%) *8	300max (Io=30-100%) *8	
	RIPPLE[mVp-p] *3	0 to +70°C	150max	150max
		-20 - 0°C	240max	240max
		Io=0 - 30%	500max	650max
	RIPPLE NOISE[mVp-p] *3	0 to +70°C	180max	180max
		-20 - 0°C	300max	300max
		Io=0 - 30%	500max	650max
	TEMPERATURE REGULATION[mV]	0 to +70°C	240max	480max
		-20 to +70°C	290max	600max
	DRIFT[mV] *4	96max	192max	
	START-UP TIME[ms]	500typ (ACIN 115V, Io=100%)		
HOLD-UP TIME[ms]	20typ (ACIN 115V, Io=100%)			
OUTPUT VOLTAGE ADJUSTMENT RANGE[V]	21.60 to 26.40	43.20 to 52.80		
OUTPUT VOLTAGE SETTING[V]	24.00 to 24.96	48.00 to 49.92		
PROTECTION CIRCUIT AND OTHERS	OVERCURRENT PROTECTION	Works over 105% of rating and recovers automatically		
	OVERVOLTAGE PROTECTION[V]	27.60 to 33.60	54.00 to 67.20	
	DC_OK LAMP	LED (Green)		
ISOLATION	INPUT-OUTPUT	AC3,000V 1minute, Cutoff current = 10mA, DC500V 50MΩ min (At Room Temperature)		
	INPUT-PE	AC2,000V 1minute, Cutoff current = 10mA, DC500V 50MΩ min (At Room Temperature)		
	OUTPUT-PE	AC500V 1minute, Cutoff current = 100mA, DC500V 50MΩ min (At Room Temperature)		
ENVIRONMENT	OPERATING TEMP., HUMID. AND ALTITUDE	-20 to +70°C, 20 - 90%RH (Non condensing), Type tested for -40°C start-up (Refer to "Derating")		
	STORAGE TEMP., HUMID. AND ALTITUDE	-30 to +85°C, 20 - 90%RH (Non condensing)		
	VIBRATION *7	10 - 55Hz, 19.6m/s ² (2G), 3minutes period, 60 minutes along Z axis (Non operating, mounted on DIN Rail)		
	IMPACT	196.1m/s ² (20G), 11ms, once each X, Y and Z axis (Packing state)		
SAFETY AND NOISE REGULATIONS	AGENCY APPROVALS	UL60950-1, C-UL (CSA60950-1), EN62368-1, UL508, Complies with DEN-AN		
	CONDUCTED NOISE	Complies with FCC-B, VCCI-B, CISPR22-B, EN55011-B, EN55022-B		
	HARMONIC ATTENUATOR	Complies with IEC61000-3-2 (Class A) *5		
OTHERS	CASE SIZE *6	38 X 124 X 117mm (W X H X D) [1.5 X 4.88 X 4.61 inches]		
	WEIGHT	580g max		
	COOLING METHOD	Convection		

*1 The value is primary surge. The current of input surge to a built-in EMI/EMC Filter (0.2ms or less) is excluded.
*2 Please contact us about dynamic load and input response.
*3 This is the value that measured on measuring board with capacitor of 22 μF and 0.1 μF at 150mm from output terminal.
Measured by 20MHz oscilloscope or Ripple-Noise meter (Equivalent to KEISOKU-GIKEN: RM103).
Please refer to the instruction manual 1.5.

*4 Drift is the change in DC output for an eight hour period after a half-hour warm-up at 25°C, with the input voltage held constant at the rated input/output.
*5 Please contact us about another class.
*6 Case size contains neither the umbo.
*7 Only as standard mounting orientation (A). Refer to "Assembling and Installation Method".
If install other than standard mounting orientation (A), please fix the power

supply for withstand the vibration and impact.
*8 Burst operation at 30% load or less.
*9 Please contact us about DC input voltage.
* To meet the specifications. Do not operate over-loaded condition.
* A sound may occur from power supply at light or peak loading.

Block diagram

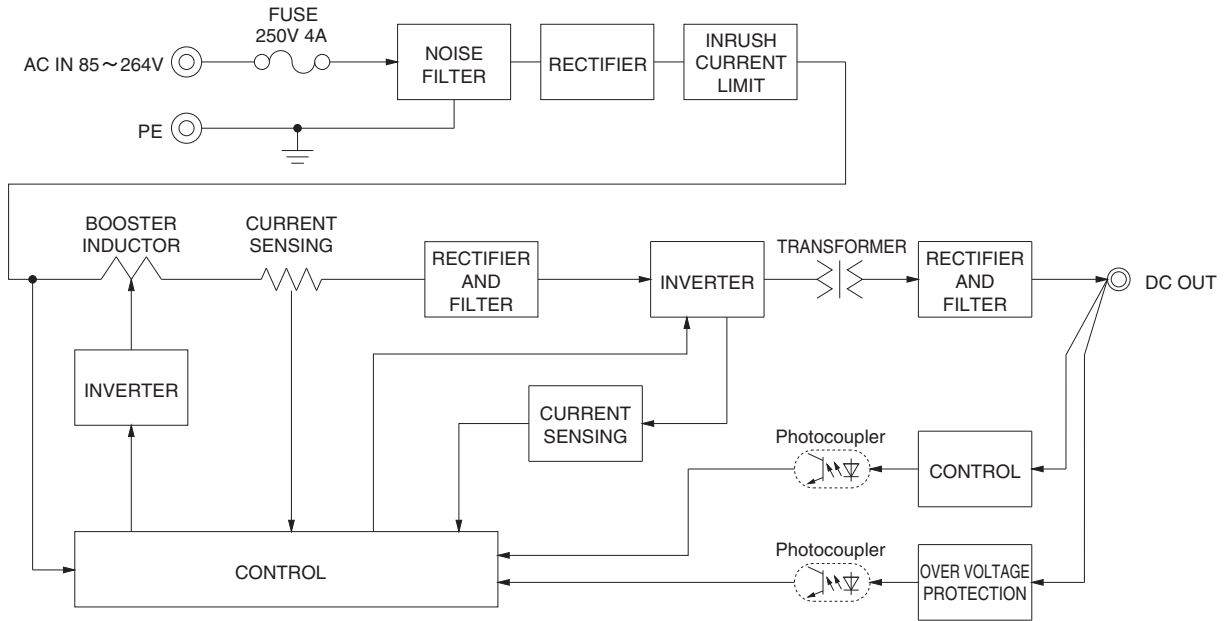

External view

<KLEA120F(Euro Style I/O Terminals)>

<KLNA120F(Barrier Blocks Style I/O Terminals)>

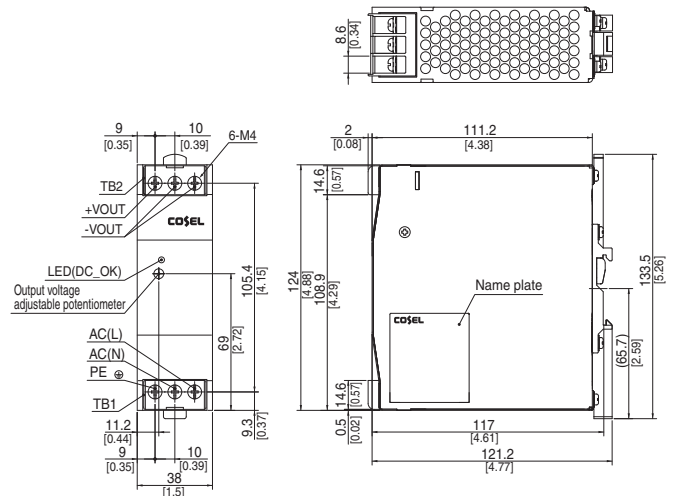
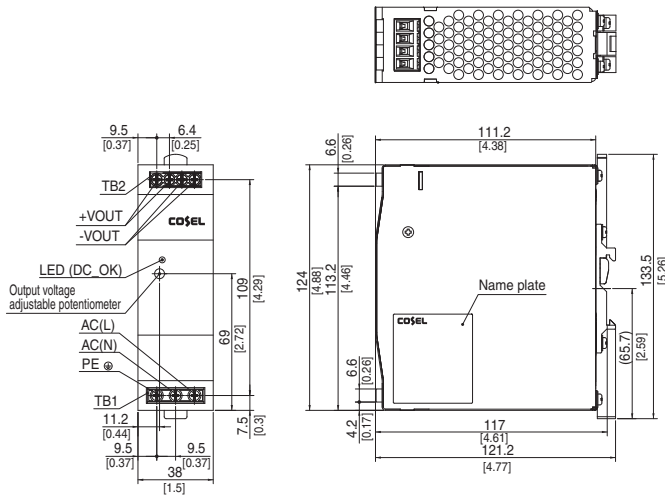

- ※ Tolerance : ± 1.5 [± 0.06]
- ※ Weight : 580g max
- ※ PCB Material/thickness : FR-4 / 1.6mm [0.06]
- ※ Chassis material : Aluminum
- ※ Case material : Stainless steel
- ※ Din rail attachment material : Aluminum, Stainless steel, Nylon
- ※ Dimensions in mm, [] = inches
- ※ Screw tightening torque : 1N · m max

- ※ Tolerance : ± 1.5 [± 0.06]
- ※ Weight : 580g max
- ※ PCB Material/thickness : FR-4 / 1.6mm [0.06]
- ※ Chassis material : Aluminum
- ※ Case material : Stainless steel
- ※ Din rail attachment material : Aluminum, Stainless steel, Nylon
- ※ Dimensions in mm, [] = inches
- ※ Screw tightening torque : 1.6N · m max

KLEA/KLNA240F

KL A 240 F - -

① ② ③ ④ ⑤ ⑥



Example recommended EMI/EMC filter
NAC-06-472-D



High voltage pulse noise type : NAP series
Low leakage current type : NAM series
*A higher current rating EMI/EMC filter may be recommended in view of the other devices that could be connected in parallel with the power supply.

- ① Series name
KLE : Euro Style I/O Terminals
KLN : Barrier Blocks Style I/O Terminals
- ② Single output
- ③ Output wattage
- ④ Universal input
- ⑤ Output voltage
- ⑥ Option
C : with Coating
N2: Screw mounting

*Make sure necessary tests will be carried out on your end equipment with the power supply installed in accordance with any required EMC/EMI regulations.

MODEL	KLEA/KLNA240F-24	KLEA/KLNA240F-48
MAX OUTPUT WATTAGE[W]	240	240
DC OUTPUT	24V 10A	48V 5A

SPECIFICATIONS

	MODEL	KLEA/KLNA240F-24	KLEA/KLNA240F-48	
INPUT	VOLTAGE[V]	AC85 - 264 1 φ (Refer to "Derating") *8		
	CURRENT[A]	ACIN 115V	2.4typ	
		ACIN 230V	1.3typ	
	FREQUENCY[Hz]	50 / 60 (45 - 66)		
	EFFICIENCY[%]	ACIN 115V	88typ	
		ACIN 230V	90typ	
	POWER FACTOR	ACIN 115V	0.98typ	
		ACIN 230V	0.90typ	
INRUSH CURRENT[A]	ACIN 115V	20typ (Io=100%)(at cold start Ta=25°C)		
	*1 ACIN 230V	40typ (Io=100%)(at cold start Ta=25°C)		
LEAKAGE CURRENT[ma]	0.45 / 0.75max (ACIN 100V / 240V 60Hz, Io=100%, According to IEC62368-1 and DEN-AN)			
OUTPUT	VOLTAGE[V]	24	48	
	CURRENT[A]	10	5	
	LINE REGULATION[mV] *2	96max		
	LOAD REGULATION[mV] *2	150max		
	RIPPLE[mVp-p] *3	0 to +70°C	150max	150max
		-20 - 0°C	240max	240max
	RIPPLE NOISE[mVp-p] *3	0 to +70°C	180max	180max
		-20 - 0°C	300max	300max
	TEMPERATURE REGULATION[mV]	0 to +70°C	240max	480max
		-20 to +70°C	290max	600max
	DRIFT[mV] *4	96max		
	START-UP TIME[ms]	500typ (ACIN 115V, Io=100%)		
	HOLD-UP TIME[ms]	20typ (ACIN 115V, Io=100%)		
OUTPUT VOLTAGE ADJUSTMENT RANGE[V]	21.60 to 26.40	43.20 to 52.80		
OUTPUT VOLTAGE SETTING[V]	24.00 to 24.96	48.00 to 49.92		
PROTECTION CIRCUIT AND OTHERS	OVERCURRENT PROTECTION	Works over 105% of rating and recovers automatically		
	OVERVOLTAGE PROTECTION[V]	27.60 to 33.60	54.00 to 67.20	
	DC_OK LAMP	LED (Green)		
ISOLATION	INPUT-OUTPUT	AC3,000V 1minute, Cutoff current = 10mA, DC500V 50MΩ min (At Room Temperature)		
	INPUT-PE	AC2,000V 1minute, Cutoff current = 10mA, DC500V 50MΩ min (At Room Temperature)		
	OUTPUT-PE	AC500V 1minute, Cutoff current = 100mA, DC500V 50MΩ min (At Room Temperature)		
ENVIRONMENT	OPERATING TEMP.,HUMID.AND ALTITUDE	-20 to +70°C, 20 - 90%RH (Non condensing), Type tested for -40°C start-up (Refer to "Derating")		
	STORAGE TEMP.,HUMID.AND ALTITUDE	-30 to +85°C, 20 - 90%RH (Non condensing)		
	VIBRATION *7	10 - 55Hz, 19.6m/s ² (2G), 3minutes period, 60 minutes along Z axis (Non operating, mounted on DIN Rail)		
	IMPACT	196.1m/s ² (20G), 11ms, once each X, Y and Z axis (Packing state)		
SAFETY AND NOISE REGULATIONS	AGENCY APPROVALS	UL60950-1, C-UL (CSA60950-1), EN62368-1, UL508, Complies with DEN-AN		
	CONDUCTED NOISE	Complies with FCC-B, VCCI-B, CISPR22-B, EN55011-B, EN55022-B		
	HARMONIC ATTENUATOR	Complies with IEC61000-3-2 (Class A) *5		
OTHERS	CASE SIZE *6	50 × 124 × 117mm (W × H × D) [1.97 × 4.88 × 4.61 inches]		
	WEIGHT	750g max		
	COOLING METHOD	Convection		

*1 The value is primary surge. The current of input surge to a built-in EMI/EMC Filter(0.2ms or less)is excluded.
*2 Please contact us about dynamic load and input response.
*3 This is the value that measured on measuring board with capacitor of 22 μF and 0.1 μF at 150mm from output terminal.
Measured by 20MHz oscilloscope or Ripple-Noise meter (Equivalent to KEISOKU-GIKEN: RM103).
Please refer to the instruction manual 1.5.

*4 Drift is the change in DC output for a eight hour period after a half-hour warm-up at 25°C, with the input voltage held constant at the rated input/output.
*5 Please contact us about another class.
*6 Case size contains neither the umbo.
*7 Only as standard mounting orientation (A). Refer to "Assembling and Installation Method".
If install other than standard mounting orientation (A), please fix the power

supply for withstand the vibration and impact.
*8 Please contact us about DC input voltage.
* To meet the specifications. Do not operate over-loaded condition.
* A sound may occur from power supply at light or peak loading.

Block diagram

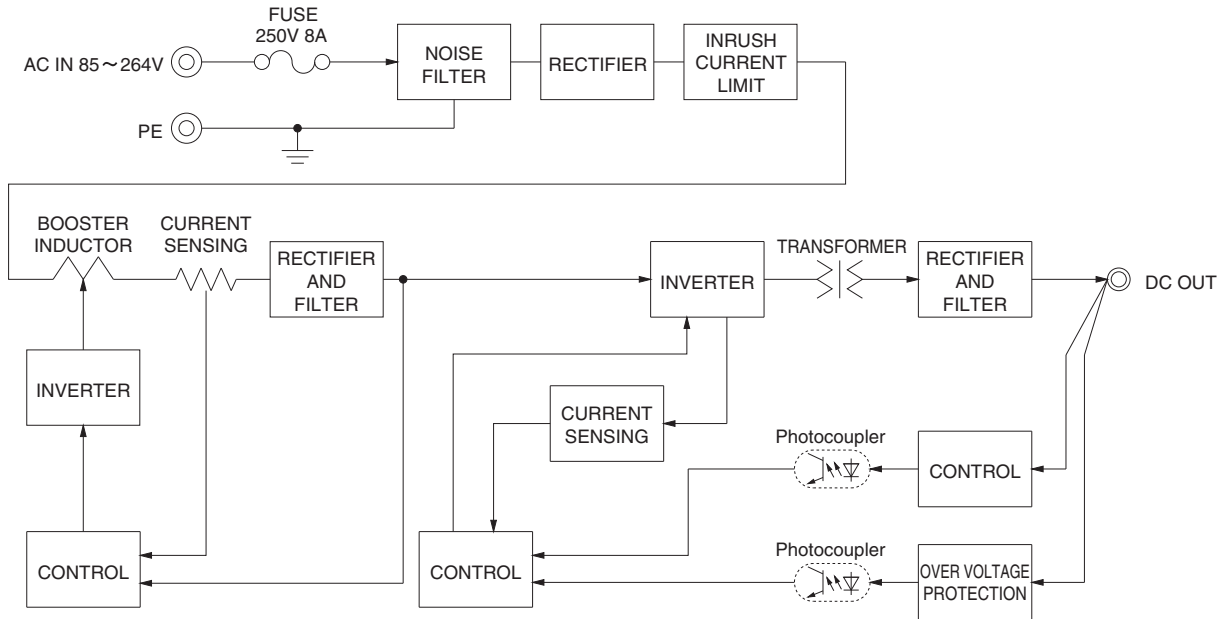

External view

<KLEA240F(Euro Style I/O Terminals)>

<KLNA240F(Barrier Blocks Style I/O Terminals)>

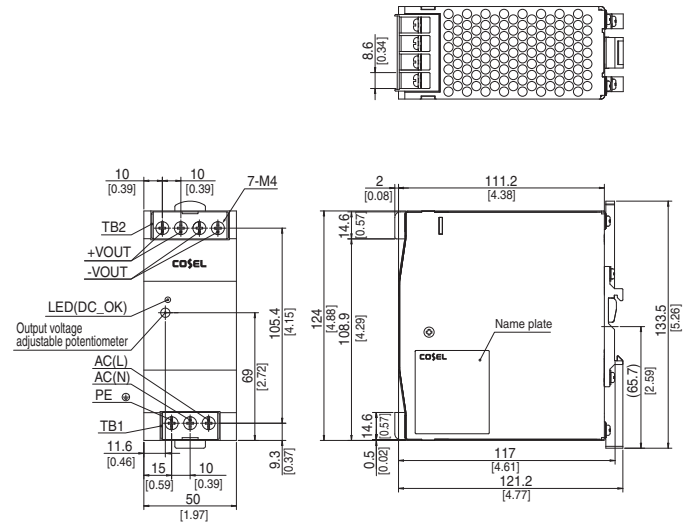
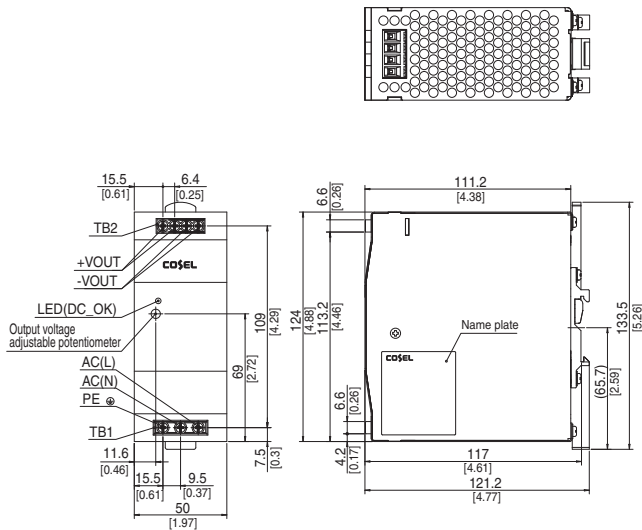

- ※ Tolerance : ±1.5 [±0.06]
- ※ Weight : 750g max
- ※ PCB Material/thickness : FR-4 / 1.6mm [0.06]
- ※ Chassis material : Aluminum
- ※ Case material : Stainless steel
- ※ Din rail attachment material : Aluminum, Stainless steel, Nylon
- ※ Dimensions in mm, [] = inches
- ※ Screw tightening torque : 1N · m max

- ※ Tolerance : ±1.5 [±0.06]
- ※ Weight : 750g max
- ※ PCB Material/thickness : FR-4 / 1.6mm [0.06]
- ※ Chassis material : Aluminum
- ※ Case material : Stainless steel
- ※ Din rail attachment material : Aluminum, Stainless steel, Nylon
- ※ Dimensions in mm, [] = inches
- ※ Screw tightening torque : 1.6N · m max

Terminal Blocks

● KLEA120F

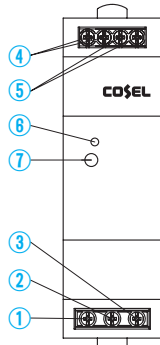

● KLNA120F

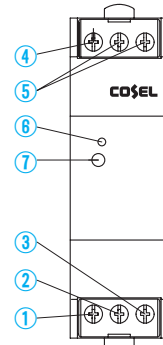

● KLEA240F

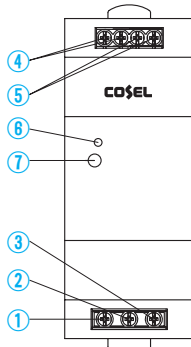

● KLNA240F

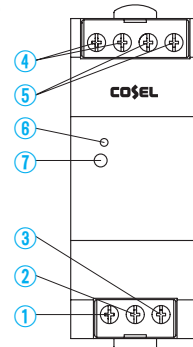

Terminal Number	Terminal Name	Function
①	PE	Protective earth Terminal
②	AC (N)	Input Terminals
③	AC (L)	
④	+VOUT	+Output Terminals
⑤	-VOUT	-Output Terminals
⑥	DC_OK	LED for output voltage confirmation
⑦	TRM	Adjustment of output voltage

Assembling and Installation Method

Installation method

■ About DIN-Rail Attachment available with DIN EN60715 TH 35 (35×7.5mm or 35×15mm) (Top hat shaped DIN rail)

■ Below shows mounting orientation.

If install other than standard mounting orientation (A), please fix the power supply for withstand the impact and vibration.

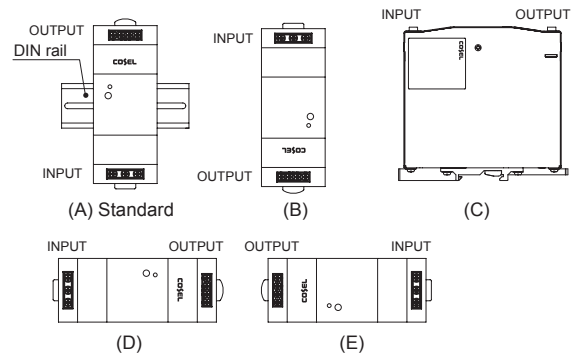

■ When you mount a power supply on a DIN rail, have the area marked A catch one side of the rail and push the unit to the direction of B. To remove the power supply from the rail, either push down the area marked C or insert a tool such as driver to the area marked D and pull the unit apart from the rail.

When you couldn't remove the unit easily, push down the area marked C while lightly pushing the unit to the direction of E.

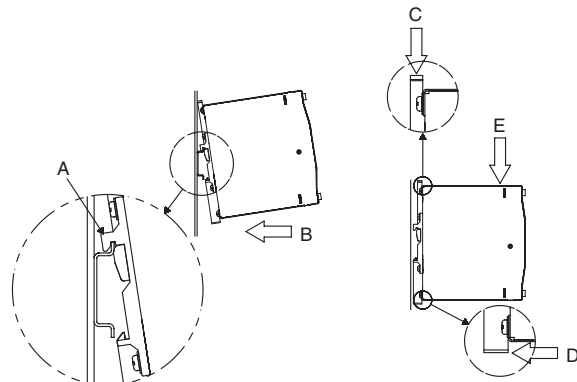

Assembling and Installation Method

■ Shown below the notes about installation clearance of a unit.

- ① Installation clearance at above and below the unit.
Please have clearance of at least 25mm above and below the unit to avoid heat accumulation.
- ② Installation clearance at the side of the unit.
Please have clearance of at least 5mm side the unit to insulating the internal components. However, refer to right figure, if adjacent device of the unit (including power supply) is a heat source.

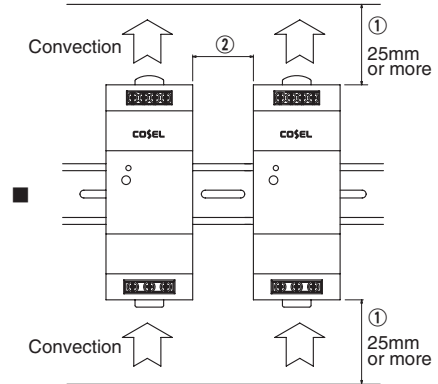

No.	Model	Adjacent device of the unit	
		Non-heat source	Heat source(*)
1	KLEA120F, KLNA120F	15mm or more	25mm or more
2	KLEA240F, KLNA240F	15mm or more	25mm or more

* Reference value when same power units are adjacent.

Derating

Derating curve for input voltage

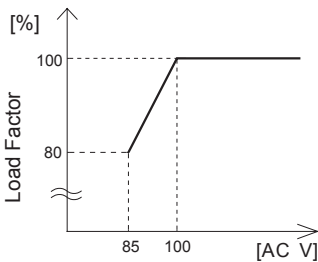

Ambient temperature derating

- The operative ambient temperature as different by input voltage. Derating curve is shown below.
- In the hatched area, the specification of Ripple, Ripple Noise is different from other area.
- Derating Curve (Convection)
- Refer to instruction manual 3 for Ambient temperature measurement point.

● KLEA120F, KLNA120F

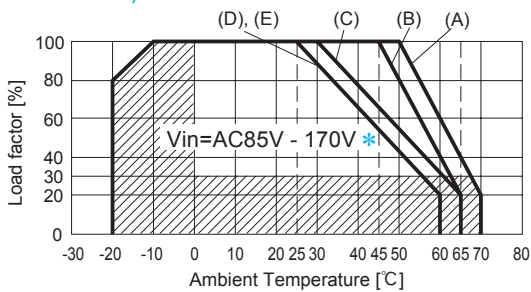

* Derating curve depend on input voltage is required.

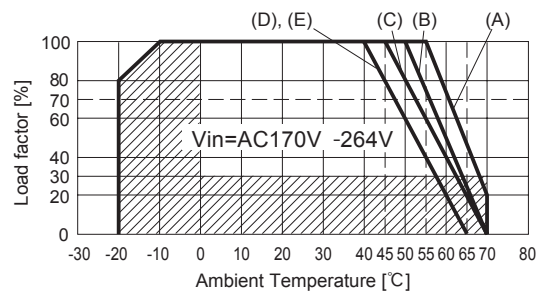

● KLEA240F, KLNA240F

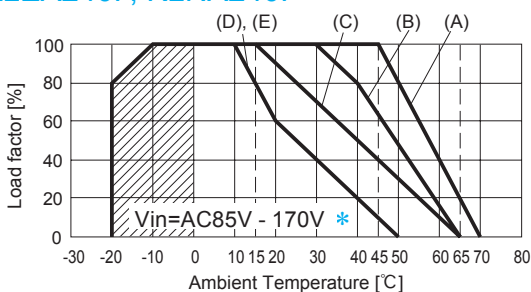

* Derating curve depend on input voltage is required.

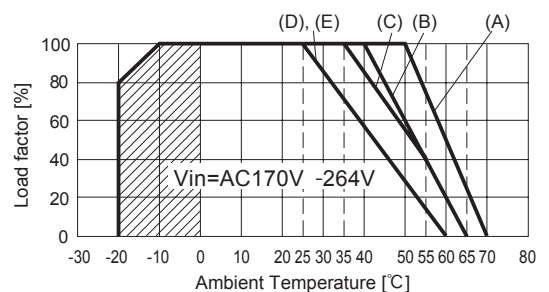

Derating

■ Derating Curve (Forced air)

■ Use the temperature measurement point as shown in instruction manual 3. Please use at the temperature dose not exceed the values in instruction manual 3.

● KLEA120F, KLNA120F

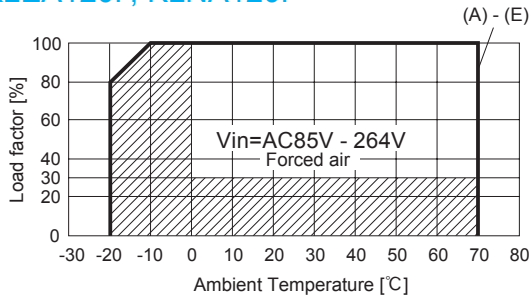

● KLEA240F, KLNA240F

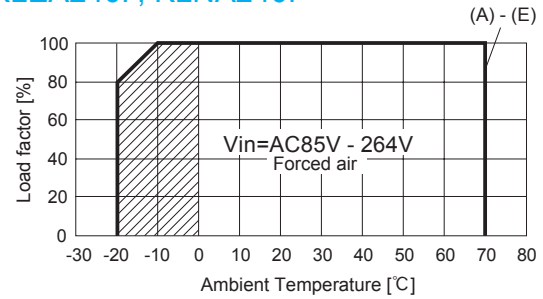

Instruction Manual

◆ It is necessary to read the “Instruction Manual” and “Before using our product” before you use our product.

Instruction Manual <https://www.cosel.co.jp/redirect/catalog/en/KL/>
 Before using our product <https://en.cosel.co.jp/technical/caution/index.html>



Basic Characteristics Data

Model	Circuit method	Switching frequency [KLz]	Input current [A] *1	Rated input fuse	Inrush current protection circuit	PCB/Pattern			Series/Parallel operation availability	
						Material	Single sided	Double sided	Series operation	Parallel operation
KLEA120F	Active filter	40 - 160	1.2	250V 4A	Thermistor	FR-4		Yes	Yes	No
KLNA120F	Flyback converter	20 - 150*2								
KLEA240F	Active filter	50 - 70	2.4	250V 8A	Thermistor	FR-4		Yes	Yes	No
KLNA240F	Forward converter	130								

*1 The value of input current is at ACIN 115V and 100%.

*2 Burst operation at light loading, frequency is change by use condition.
 Please contact us about detail.



KR-series



KRE-20A

KRE-40A

Feature

- Redundancy module
- For DIN (35mm) rail products
- Wide input voltage range
- Wide operating ambient temperature range
- Input voltage balance OK LED
- Input voltage OK LED and relay output

Safety agency approvals

UL60950-1, UL508, C-UL (CSA60950-1), EN62368-1

CE marking

Low Voltage Directive
RoHS Directive

UKCA marking

Electrical Equipment Safety Regulations
RoHS Regulations

EMI

Complies with FCC-B, CISPR22-B, EN55011-B, EN55022-B, VCCI-B

EMS Compliance : EN61204-3, EN61000-6-2

EN61000-4-2
EN61000-4-3
EN61000-4-4
EN61000-4-6

5-year warranty

KRE -20A / -40A

KRE -□□A

①

②



① Series name
KRE : Euro style I/O terminals
② Output current

MODEL	KRE-20A	KRE-40A
DC OUTPUT CURRENT	20	40
DC PEAK OUTPUT CURRENT	30	60

SPECIFICATIONS

	MODEL	KRE-20A	KRE-40A
INPUT	VOLTAGE[V]	DC10 ~ 60	DC10 ~ 30
	CURRENT[A]	10 (×2 Input)	20 (×2 Input)
	PEAK CURRENT[A]	15 (×2 Input)	30 (×2 Input)
	INPUT-OUTPUT POTENTIAL DIFFERENCE[V]	0.6typ (Ta=25°C ,Io=100%)	0.4typ (Ta=25°C ,Io=100%)
OUTPUT	CURRENT[A]	20	40
	PEAK CURRENT[A]	*1 30	60
FUNCTION	DC_OK LAMP	LED (Green)	
	Balance_OK LAMP	LED (Green)	
	DC_OK CONTACT	Relay contact 30VDC 0.5Amax , 30VAC 0.5Amax (resistive load)	
ISOLATION	INPUT-OUTPUT-Chassis	AC1,000V 1minute, Cutoff current = 100mA, DC500V 50MΩ min (At Room Temperature)	
	INPUT-OUTPUT-DC_OK	AC500V 1minute, Cutoff current = 100mA, DC500V 50MΩ min (At Room Temperature)	
	DC_OK-Chassis	AC500V 1minute, Cutoff current = 100mA, DC500V 50MΩ min (At Room Temperature)	
ENVIRONMENT	OPERATING TEMP., HUMID. AND ALTITUDE	-25 to +70°C (Refer to "Derating"), 20 - 90%RH (Non condensing)	
	STORAGE TEMP., HUMID. AND ALTITUDE	-25 to +85°C, 20 - 90%RH (Non condensing)	
	VIBRATION	*2 10 - 55Hz, 19.6m/s ² (2G), 3minutes period, 60 minutes along Z axis (Non operating, mounted on DIN Rail)	
	IMPACT	196.1m/s ² (20G), 11ms, once each X, Y and Z axis (Packing state)	
SAFETY	AGENCY APPROVALS	UL60950-1, C-UL (CSA60950-1), EN62368-1, UL508	
	CE MARKING	LVD	
OTHERS	CASE SIZE	*3 38×124×117mm (W×H×D) [1.5X4.88X4.61 inches]	
	WEIGHT	480g max	610gmax
	COOLING METHOD	Convection	

*1 Refer to 2, instruction manual.

*2 Only as standard mounting orientation (A). Refer to the "Assembling and Installation Method".

*3 If install other than standard mounting orientation (A), please fix the power supply for withstand the vibration and impact.

*4 Case size contains neither the umbo.

*5 To meet the specifications. Do not operate over-loaded condition.

Block diagram

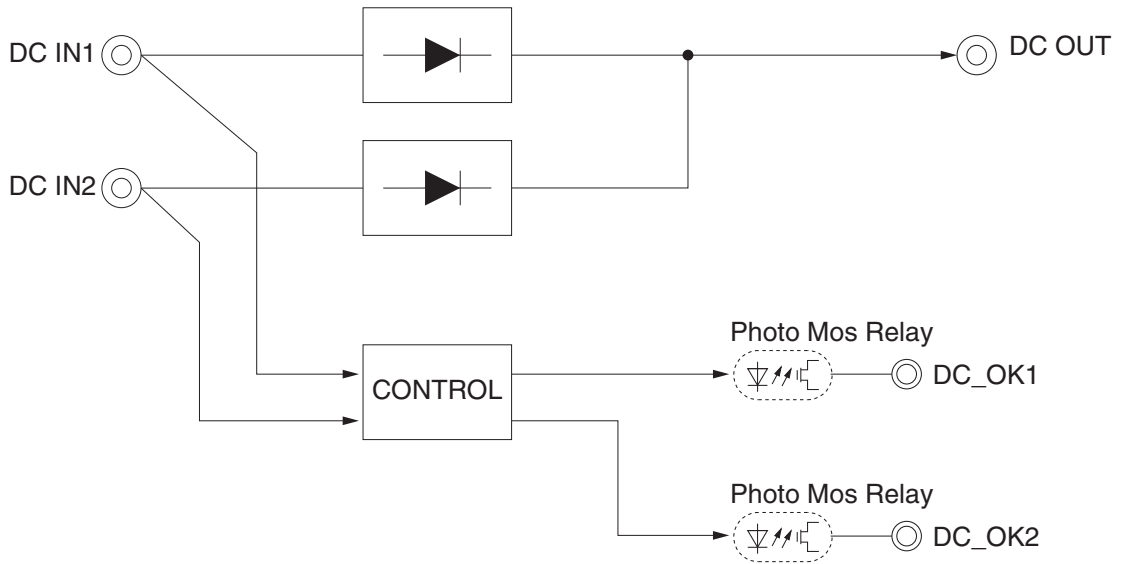

External view

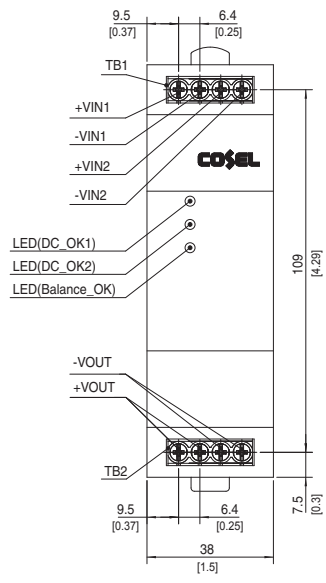
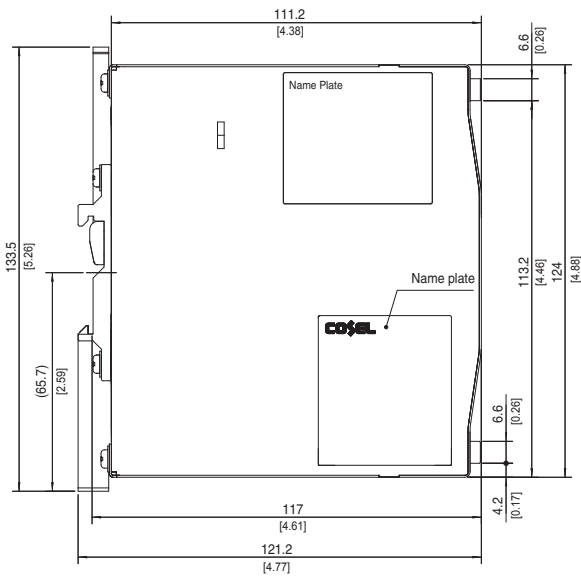
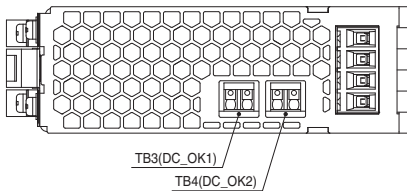

- ※ Tolerance : ±1.5 [±0.06]
- ※ Weight : KRE-20A 480g max
KRE-40A 610g max
- ※ PCB Material/thickness : FR-4 / 1.6mm [0.06]
- ※ Chassis material : Aluminum
- ※ Case material : Stainless steel
- ※ DIN rail attachment material : Aluminum,
Stainless steel, Nylon
- ※ Dimensions in mm, [] = inches
- ※ Screw tightening torque : 1N · m max

Terminal Blocks

● KRE-20A/-40A

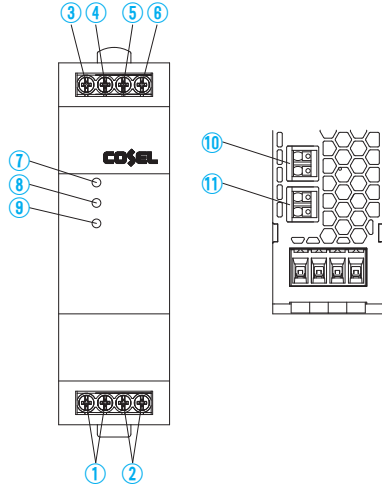

Terminal Number	Terminal Name	Function
①	+VOUT	+Output Terminals
②	-VOUT	-Output Terminals
③	+VIN1	+Input Terminals 1
④	-VIN1	-Input Terminals 1
⑤	+VIN2	+Input Terminals 2
⑥	-VIN2	-Input Terminals 2
⑦	DC_OK1	LED for input voltage 1 confirmation
⑧	DC_OK2	LED for input voltage 2 confirmation
⑨	Balance_OK	LED for input voltage balance confirmation
⑩	DC_OK1	Input voltage 1 confirmation (relay contact)
⑪	DC_OK2	Input voltage 2 confirmation (relay contact)

Assembling and Installation Method

Installation method

■ About DIN-Rail Attachment available with DIN EN60715 TH 35 (35×7.5mm or 35×15mm) (Top hat shaped DIN rail)

■ Below shows mounting orientation.

If install other than standard mounting orientation (A), please fix the power supply for withstand the impact and vibration.

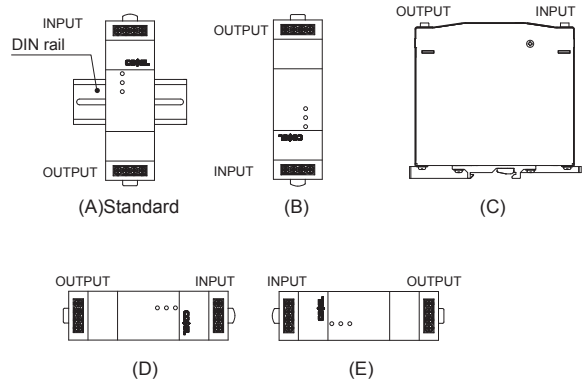

■ When you mount a power supply on a DIN rail, have the area marked A catch one side of the rail and push the unit to the direction of B. To remove the power supply from the rail, either push down the area marked C or insert a tool such as driver to the area marked D and pull the unit apart from the rail.

When you couldn't remove the unit easily, push down the area marked C while lightly pushing the unit to the direction of E.

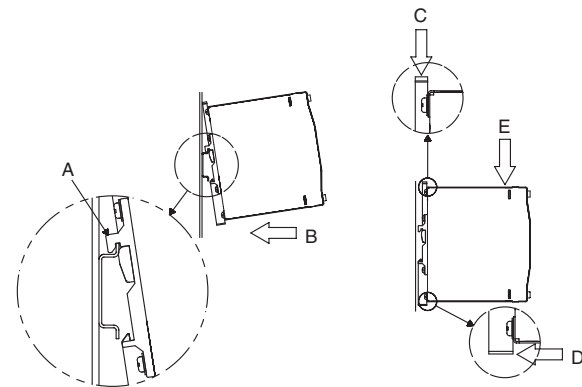

■ Shown below the notes about installation clearance of a unit.

- ① Installation clearance at above and below the unit.
Please have clearance of at least 25mm above and below the unit to avoid heat accumulation.
- ② Installation clearance at the side of the unit.
Please have clearance of at least 15mm side the unit to avoid interfering with heat radiation from housing.

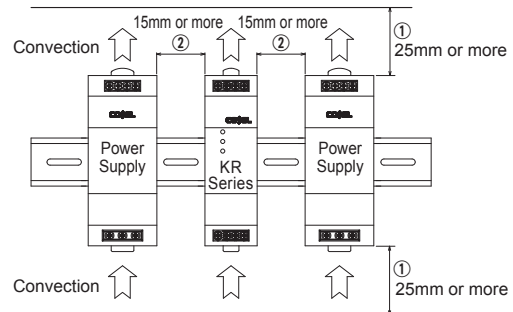

Derating

Ambient temperature derating

- The operative ambient temperature as different by input voltage. Derating curve is shown below.
- Derating Curve (Convection)
- Refer to instruction manual 3 for Ambient temperature measurement point.

● KRE-20A

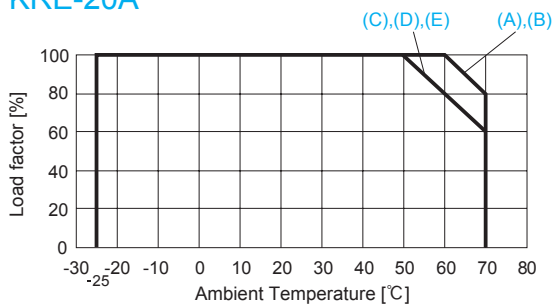

● KRE-40A

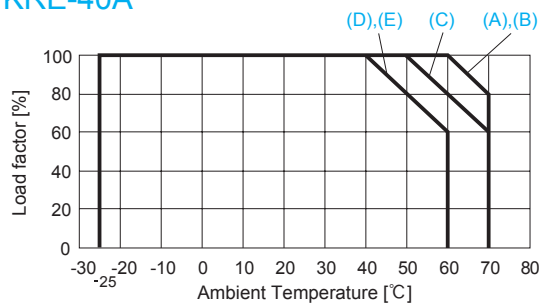

- Derating Curve (Forced air)
 - * UL508 (Listing) is excluded.
- Use the temperature measurement point as shown in instruction manual 3. Please use at the temperature dose not exceed the values in instruction manual 3.

● KRE-20A/40A

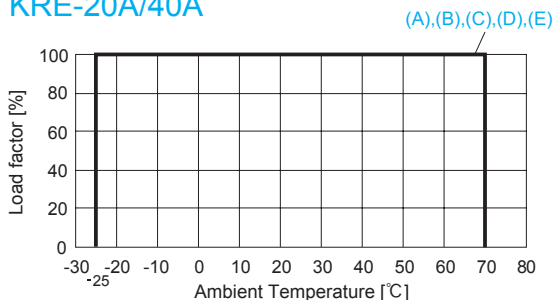

Instruction Manual

- ◆ It is necessary to read the "Instruction Manual" and "Before using our product" before you use our product.

Instruction Manual <https://www.cosel.co.jp/redirect/catalog/en/KR/>
 Before using our product <https://en.cosel.co.jp/technical/caution/index.html>



KR

Basic Characteristics Data

Model	Circuit method	PCB/Pattern		
		Material	Single sided	Double sided
KRE-20A	Diode	FR-4		Yes
KRE-40A	Diode	FR-4		Yes



LMA-series

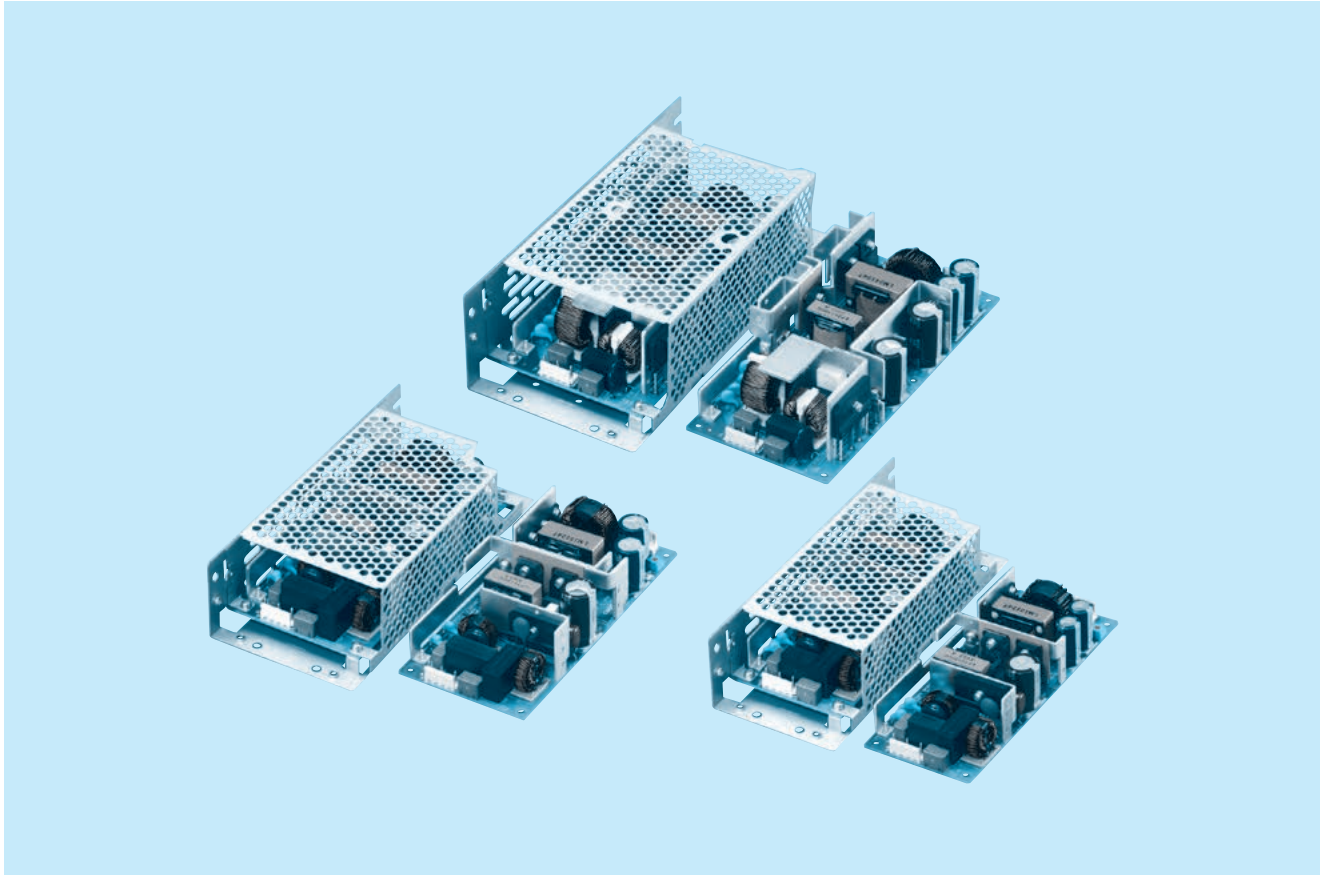

Feature

- For medical electric equipment
- Internal dual fuses
- Low leakage current
- High power & peak power (option)
- Small and compact PCB construction
- Built-in inrush current, overcurrent and overvoltage protection circuits
- Harmonic attenuator (Complies with IEC61000-3-2 class A)
- Universal input (AC85-264V)
- Power factor correction

Safety agency approvals

ANSI/AAMI ES60601, EN60601-1 3rd

EMI

Complies with FCC-B, CISPR22-B, EN55011-B, EN55022-B, VCCI-B

5-year warranty

CE marking

Low Voltage Directive
RoHS Directive

UKCA marking

Electrical Equipment Safety Regulations
RoHS Regulations

EMS Compliance

: EN61204-3, EN61000-6-2
IEC60601-1-2 (2014), EN60601-1-2 (2015)

- EN61000-4-2
- EN61000-4-3
- EN61000-4-4
- EN61000-4-5
- EN61000-4-6
- EN61000-4-8
- EN61000-4-11

LMA100F

LM A 100 F -□ -□
 ① ② ③ ④ ⑤ ⑥

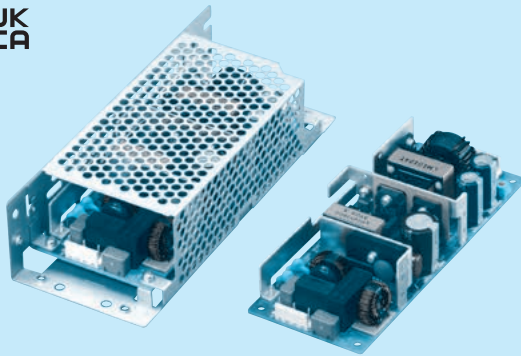

Example recommended EMI/EMC filter
NAM-04-101



High voltage pulse noise type : NAP series
 Low leakage current type : NAM series
 *A higher current rating EMI/EMC filter may be recommended in view of the other devices that could be connected in parallel with the power supply.

- ① Series name
- ② Single output
- ③ Output wattage
- ④ Universal input
- ⑤ Output voltage
- ⑥ Optional *1
- C : with Coating
- G : Low leakage current
- H : with the function to be acceptable to output peak current
- J1 : VH(J.S.T.)connector type
- R : with Remote ON/OFF
- R2 : with Remote ON/OFF
- S : with Chassis
- SN : with Chassis & cover
- P :Setting in the overcurrent protection rating

This power supply is manufactured by SMD technology. The stress to P.C.B like twisting or bending causes the defect of the unit, so handle the unit with care.
 *Make sure necessary tests will be carried out on your end equipment with the power supply installed in accordance with any required EMC/EMI regulations.

MODEL	LMA100F-24-Y	LMA100F-24-HY
MAX OUTPUT WATTAGE[W]	103.2	103.2 (206.4) *2
DC OUTPUT	24V 4.3A	24V 4.3A (8.6A) *2

SPECIFICATIONS

	MODEL	LMA100F-24-Y	LMA100F-24-HY	
INPUT	VOLTAGE[V]	AC85 - 264 1 φ (Refer to "Derating", Instruction Manual 1 and 3)		
	CURRENT[A]	ACIN 100V	1.4typ (Io=100%)	
		ACIN 200V	0.7typ (Io=100%)	
	FREQUENCY[Hz]	50 / 60 (47 - 63)		
	EFFICIENCY[%]	ACIN 100V	84.0typ (Io=100%)	
		ACIN 200V	86.0typ (Io=100%)	
	POWER FACTOR	ACIN 100V	0.99typ (Io=100%)	
INRUSH CURRENT[A]	ACIN 100V	15typ (Io=100%) (At cold start) (Ta=25°C)		
	ACIN 200V	30typ (Io=100%) (At cold start) (Ta=25°C)		
LEAKAGE CURRENT[mA]	0.10 / 0.25max (ACIN 100V / 240V 60Hz, Io=100%, According to IEC60601-1)			
OUTPUT	VOLTAGE[V]	24	24	
	CURRENT[A]	4.3	4.3 (Peak 8.6) *2	
	LINE REGULATION[mV]	*7 96max	96max	
	LOAD REGULATION[mV]	*7 150max	150max	
	RIPPLE[mVp-p]	*3 0 to +50°C	120max	120max
		-10 - 0°C	160max	160max
	RIPPLE NOISE[mVp-p]*3	0 to +50°C	150max	150max
		-10 - 0°C	180max	180max
	TEMPERATURE REGULATION[mV]	0 to +50°C	240max	240max
		-10 to +50°C	290max	290max
	DRIFT[mV]	*4 96max	96max	
	START-UP TIME[ms]	350typ (ACIN 100V, Io=100%)		
	HOLD-UP TIME[ms]	20typ (ACIN 100V, Io=100%)		
OUTPUT VOLTAGE ADJUSTMENT RANGE[V]	19.20 to 27.50			
OUTPUT VOLTAGE SETTING[V]	24.00 to 24.96	24.00 to 24.96		
PROTECTION CIRCUIT AND OTHERS	OVERCURRENT PROTECTION	Works over 105% of rating (works over 101% of peak current at option -H) and recovers automatically		
	OVERVOLTAGE PROTECTION[V]	27.60 to 33.60	27.60 to 33.60	
	OPERATING INDICATION	Not provided		
	REMOTE SENSING	Not provided		
ISOLATION	REMOTE ON/OFF	Option (Required external power source.)		
	INPUT-OUTPUT-RC	*6 AC4,000V 1minute, Cutoff current = 10mA, DC500V 50MΩ min (At Room Temperature) 2MOOP		
	INPUT-FG	AC2,000V 1minute, Cutoff current = 10mA, DC500V 50MΩ min (At Room Temperature) 1MOOP		
	OUTPUT-RC-FG	*6 AC500V 1minute, Cutoff current = 25mA, DC500V 50MΩ min (At Room Temperature)		
	OUTPUT-RC	*6 AC100V 1minute, Cutoff current = 25mA, DC100V 10MΩ min (At Room Temperature)		
ENVIRONMENT	OPERATING TEMP., HUMID. AND ALTITUDE *5	-10 to +70°C, 20 - 90%RH (Non condensing), (Refer to "Derating", Instruction Manual 3) 3,000m (10,000feet) max		
	STORAGE TEMP., HUMID. AND ALTITUDE	-20 to +75°C, 20 - 90%RH (Non condensing), 9,000m (30,000feet) max		
	VIBRATION	10 - 55Hz, 19.6m/s ² (2G), 3minutes period, 60minutes each along X, Y and Z axis		
SAFETY AND NOISE REGULATIONS	IMPACT	196.1m/s ² (20G), 11ms, once each X, Y and Z axis		
	AGENCY APPROVALS (AT ONLY AC input)	ANSI/AAMI ES60601-1, EN60601-1 3rd, Complies with IEC60601-1-2 4th Ed.		
	CONDUCTED NOISE	Complies with FCC-B, VCCI-B, CISPR22-B, EN55011-B, EN55022-B		
OTHERS	HARMONIC ATTENUATOR	Complies with IEC61000-3-2 (Class A) *8		
	CASE SIZE/WEIGHT	62 X 33 X 155mm [2.44 X 1.30 X 6.10 inches] (W X H X D) / 290g max (with chassis & cover : 470g max)		
	COOLING METHOD	Convection (Refer to "Derating", Instruction Manual 3) *5		

*1 Specification is changed at option, refer to Instruction Manual.

*2 Peak loading for 10sec. And Duty 40% max.

() means peak current. There is a possibility that an internal device is damaged when the specification is exceeded.

*3 This is the value that measured on measuring board with capacitor of 22 μF at 150mm from output terminal.
 Measured by 20MHz oscilloscope or Ripple-Noise meter (Equivalent to KEISOKU-GIKEN: RM103).

*4 Drift is the change in DC output for an eight hour period after a half-hour warm-up at 25°C, with the input voltage held constant at the rated input/output.

*5 Derating is required.

*6 Applicable when remote control (optional) is added.

*7 Please contact us about dynamic load and input response.

*8 Please contact us about another class.

* To meet the specifications. Do not operate over-loaded condition.

* Parallel operation is not possible.

* Derating is required when operated with chassis and cover.

* Sound noise may be generated by power supply in case of pulse load.

Block diagram

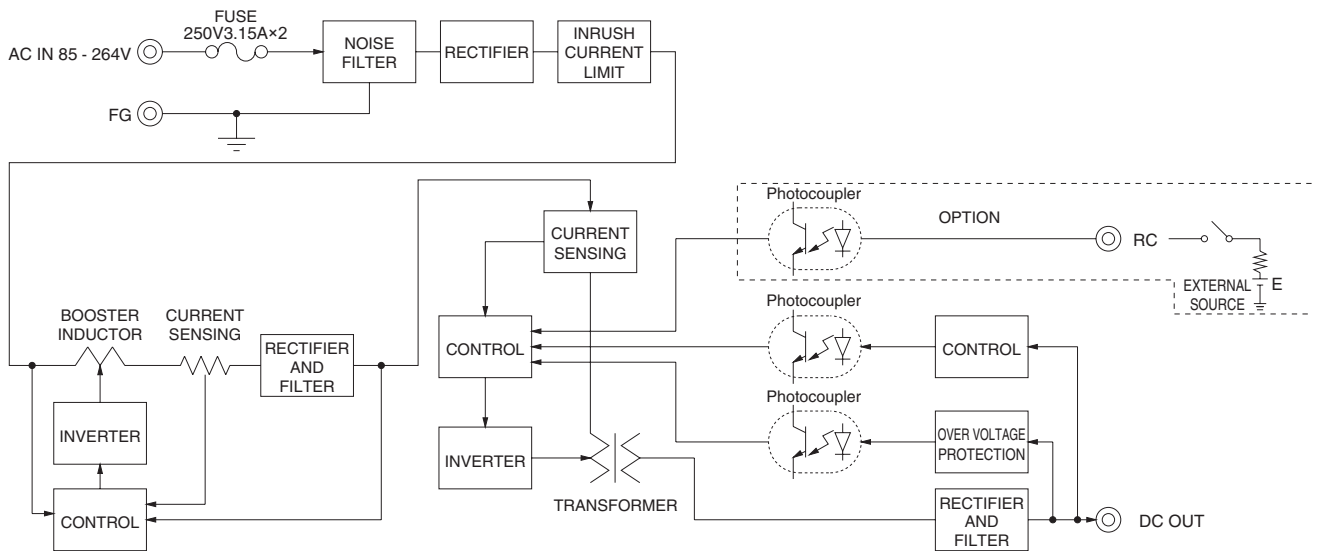

External view

※ External size of option is different from standard model.

Standard type

Chassis and cover type

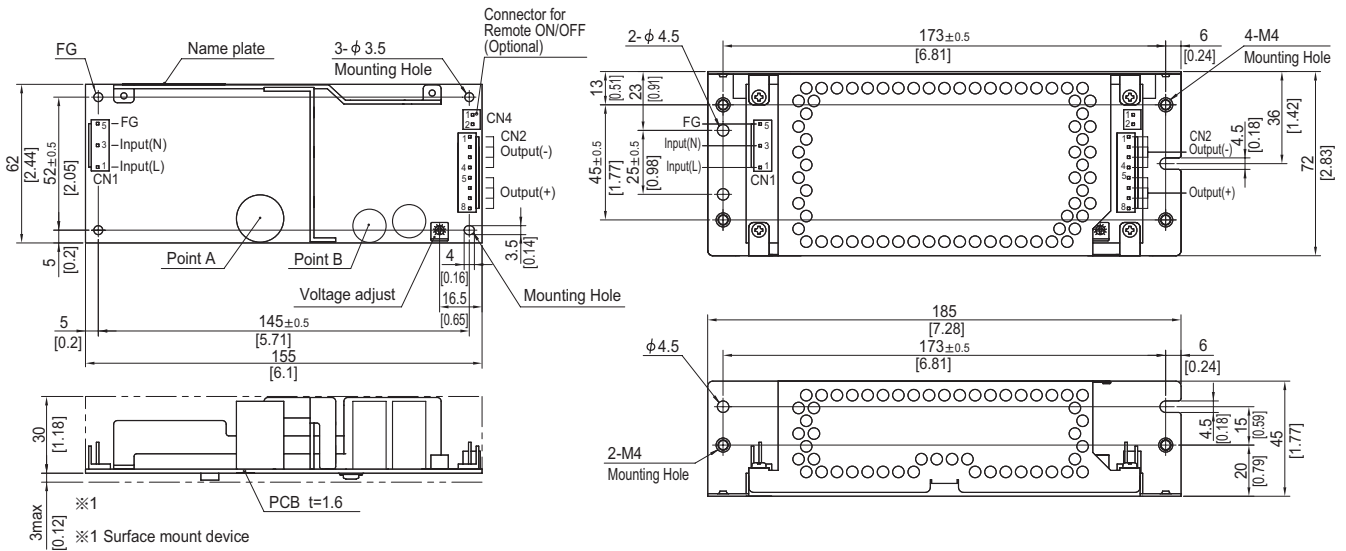

- ※ 4 Mounting holes are existing.
- ※ The back side of P.C.B. of the power supply is assembled some SMDs.
Be attention not to bump against the attached area by vibration.
- ※ Use the spacer of 8mm length or more regarding insulation.
And do not use press-fitting bush.
- ※ Point A, Point B are thermometry points.

I/O Connector	Mating connector	Terminal
CN1	1-1123724-3	Chain 1123721-1 Loose 1318912-1
CN2	1-1123723-8	Chain 1123721-1 Loose 1318912-1

(Mfr:Tyco Electronics)

- ※ I/O Connector is Mfr. Tyco Electronics
- ※ Option:-J1:VH(J.S.T) connector type.

<PIN CONNECTION>

CN1		CN2	
Pin No.	Input	Pin No.	Output
1	AC(L)	1 to 4	-V
2		5 to 8	+V
3	AC(N)		
4			
5	FG		

※ Keep drawing current per pin below 5A for CN2.

- ※ Tolerance : ± 1 [± 0.04]
- ※ Weight : 290g max (with chassis & cover : 470g max)
- ※ PCB material : CEM3
- ※ Optional chassis and cover material : Electric galvanizing steel board.
- ※ Dimensions in mm, []=inches
- ※ Mounting torque (Mounting hole of chassis) : $1.5N \cdot m$ (16kgf · cm) max

Connector type

CN4 Option (Mfr:J.S.T)	
PIN No.	Contents
1	RC(+)
2	RC(-)

Barrier strip type

Model B2B-XH-A
Mating Connector (Terminal)
XHP-2
(BXH-001T-P0.6
or SXH-001T-P0.6)

LMA150F

LM A 150 F -□ -□
 ① ② ③ ④ ⑤ ⑥

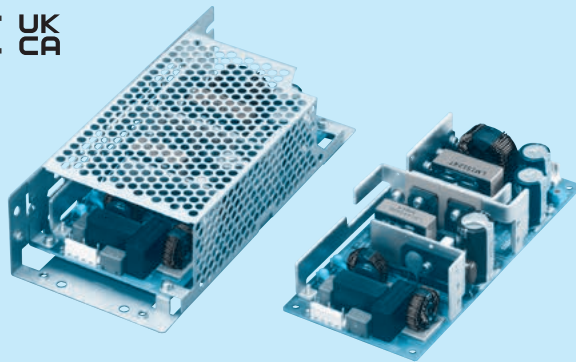

Example recommended EMI/EMC filter
NAM-04-101



High voltage pulse noise type : NAP series
 Low leakage current type : NAM series
 * A higher current rating EMI/EMC filter may be recommended in view of the other devices that could be connected in parallel with the power supply.

- ① Series name
- ② Single output
- ③ Output wattage
- ④ Universal input
- ⑤ Output voltage
- ⑥ Optional *1
- C : with Coating
- G : Low leakage current
- H : with the function to be acceptable to output peak current
- J1 : VH(J.S.T.)connector type
- R : with Remote ON/OFF
- R2 : with Remote ON/OFF
- S : with Chassis
- SN : with Chassis & cover
- P : Setting in the overcurrent protection rating

This power supply is manufactured by SMD technology. The stress to P.C.B like twisting or bending causes the defect of the unit, so handle the unit with care.
 *Make sure necessary tests will be carried out on your end equipment with the power supply installed in accordance with any required EMC/EMI regulations.

MODEL	LMA150F-24-Y	LMA150F-24-HY
MAX OUTPUT WATTAGE[W]	151.2	151.2 (302.4) *2
DC OUTPUT	24V 6.3A	24V 6.3A (12.6A) *2

SPECIFICATIONS

	MODEL	LMA150F-24-Y	LMA150F-24-HY	
INPUT	VOLTAGE[V]	AC85 - 264 1 φ (Refer to "Derating", Instruction Manual 1 and 3)		
	CURRENT[A]	ACIN 100V	2.0typ (Io=100%)	
		ACIN 200V	1.0typ (Io=100%)	
	FREQUENCY[Hz]	50 / 60 (47 - 63)		
	EFFICIENCY[%]	ACIN 100V	85.0typ (Io=100%)	
		ACIN 200V	87.0typ (Io=100%)	
	POWER FACTOR	ACIN 100V	0.99typ (Io=100%)	
INRUSH CURRENT[A]	ACIN 100V	15typ (Io=100%) (At cold start) (Ta=25°C)		
	ACIN 200V	30typ (Io=100%) (At cold start) (Ta=25°C)		
LEAKAGE CURRENT[mA]	0.10 / 0.25max (ACIN 100V / 240V 60Hz, Io=100%, According to IEC60601-1)			
OUTPUT	VOLTAGE[V]	24	24	
	CURRENT[A]	6.3	6.3 (Peak 12.6) *2	
	LINE REGULATION[mV]	*7 96max	96max	
	LOAD REGULATION[mV]	*7 150max	150max	
	RIPPLE[mVp-p]	*3 0 to +50°C	120max	120max
		-10 - 0°C	160max	160max
	RIPPLE NOISE[mVp-p]*3	0 to +50°C	150max	150max
		-10 - 0°C	180max	180max
	TEMPERATURE REGULATION[mV]	0 to +50°C	240max	240max
		-10 to +50°C	290max	290max
	DRIFT[mV]	*4 96max	96max	
	START-UP TIME[ms]	350typ (ACIN 100V, Io=100%)		
	HOLD-UP TIME[ms]	20typ (ACIN 100V, Io=100%)		
OUTPUT VOLTAGE ADJUSTMENT RANGE[V]	19.20 to 27.50			
OUTPUT VOLTAGE SETTING[V]	24.00 to 24.96			
PROTECTION CIRCUIT AND OTHERS	OVERCURRENT PROTECTION	Works over 105% of rating (works over 101% of peak current at option -H) and recovers automatically		
	OVERVOLTAGE PROTECTION[V]	27.60 to 33.60	27.60 to 33.60	
	OPERATING INDICATION	Not provided		
	REMOTE SENSING	Not provided		
ISOLATION	REMOTE ON/OFF	Option (Required external power source.)		
	INPUT-OUTPUT-RC	*6 AC4,000V 1minute, Cutoff current = 10mA, DC500V 50MΩ min (At Room Temperature) 2MOOP		
	INPUT-FG	AC2,000V 1minute, Cutoff current = 10mA, DC500V 50MΩ min (At Room Temperature) 1MOOP		
	OUTPUT-RC-FG	*6 AC500V 1minute, Cutoff current = 25mA, DC500V 50MΩ min (At Room Temperature)		
	OUTPUT-RC	*6 AC100V 1minute, Cutoff current = 25mA, DC100V 10MΩ min (At Room Temperature)		
ENVIRONMENT	OPERATING TEMP., HUMID. AND ALTITUDE *5	-10 to +70°C, 20 - 90%RH (Non condensing), (Refer to "Derating", Instruction Manual 3) 3,000m (10,000feet) max		
	STORAGE TEMP., HUMID. AND ALTITUDE	-20 to +75°C, 20 - 90%RH (Non condensing), 9,000m (30,000feet) max		
	VIBRATION	10 - 55Hz, 19.6m/s ² (2G), 3minutes period, 60minutes each along X, Y and Z axis		
SAFETY AND NOISE REGULATIONS	IMPACT	196.1m/s ² (20G), 11ms, once each X, Y and Z axis		
	AGENCY APPROVALS (AT ONLY AC input)	ANSI/AAMI ES60601-1, EN60601-1 3rd, Complies with IEC60601-1-2 4th Ed.		
	CONDUCTED NOISE	Complies with FCC-B, VCCI-B, CISPR22-B, EN55011-B, EN55022-B		
OTHERS	HARMONIC ATTENUATOR	Complies with IEC61000-3-2 (Class A) *8		
	CASE SIZE/WEIGHT	75 X 36.5 X 160mm [2.95 X 1.44 X 6.30 inches] (W X H X D) / 370g max (with chassis & cover : 600g max)		
	COOLING METHOD	Convection (Refer to "Derating", Instruction Manual 3) *5		

*1 Specification is changed at option, refer to Instruction Manual.
 *2 Peak loading for 10sec. And Duty 40% max.
 () means peak current. There is a possibility that an internal device is damaged when the specification is exceeded.
 *3 This is the value that measured on measuring board with capacitor of 22 μF at 150mm from output terminal.
 Measured by 20MHz oscilloscope or Ripple-Noise meter (Equivalent to KEISOKU-GIKEN: RM103).

*4 Drift is the change in DC output for an eight hour period after a half-hour warm-up at 25°C, with the input voltage held constant at the rated input/output.
 *5 Derating is required.
 *6 Applicable when remote control (optional) is added.
 *7 Please contact us about dynamic load and input response.
 *8 Please contact us about another class.

* To meet the specifications. Do not operate over-loaded condition.
 * Parallel operation is not possible.
 * Derating is required when operated with chassis and cover.
 * Sound noise may be generated by power supply in case of pulse load.

Block diagram

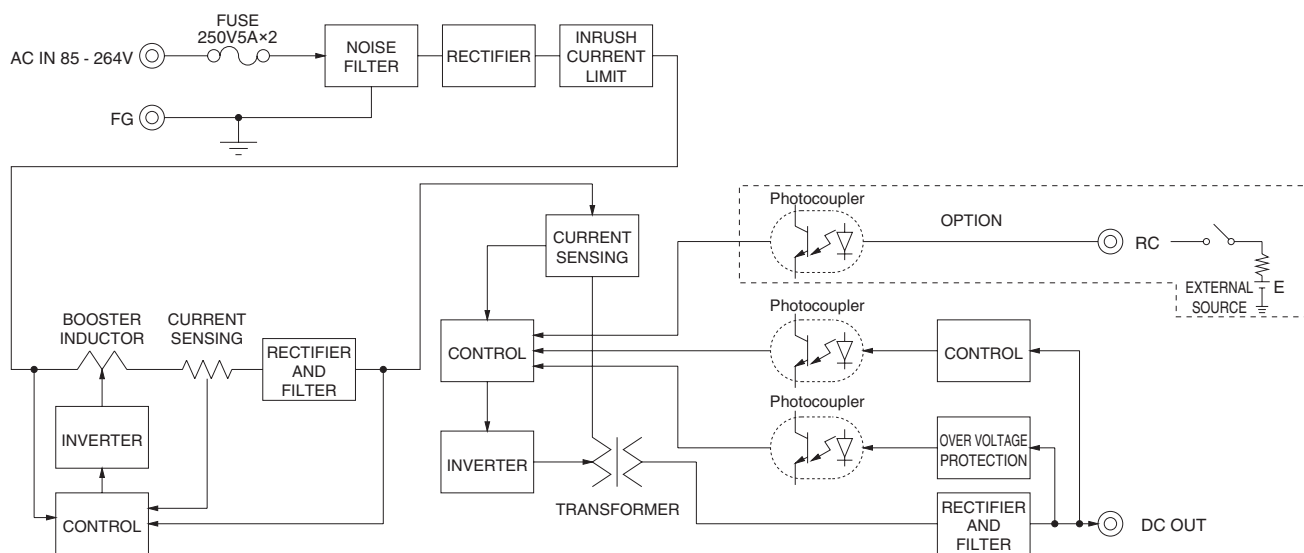

External view

※ External size of option is different from standard model.

Standard type

Chassis and cover type

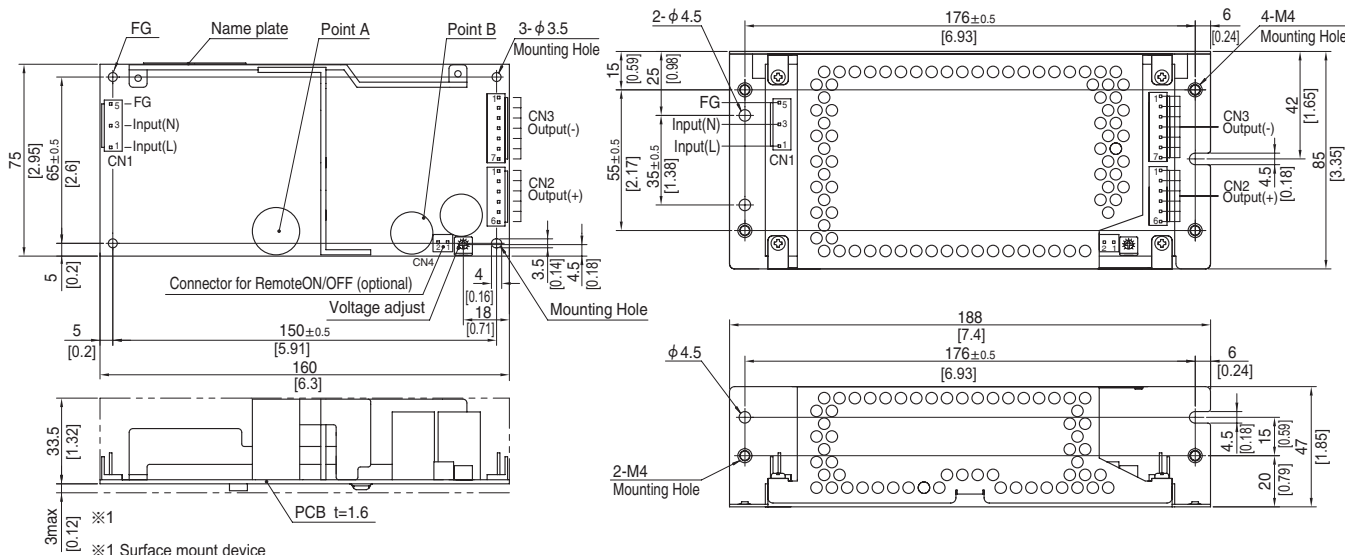

- ※ 1 Surface mount device
- ※ 4 Mounting holes are existing.
- ※ The back side of P.C.B. of the power supply is assembled some SMDs.
Be attention not to bump against the attached area by vibration.
- ※ Use the spacer of 8mm length or more regarding insulation.
And do not use press-fitting bush.
- ※ Point A, Point B are thermometry points.

I/O Connector	Mating connector	Terminal
CN1	1-1123724-3	Chain 1123721-1
		Loose 1318912-1
CN2	1-1123723-6	Chain 1123721-1
		Loose 1318912-1
CN3	1-1123723-7	Chain 1123721-1
		Loose 1318912-1

(Mfr: Tyco Electronics)

- ※ I/O Connector is Mfr. Tyco Electronics
- ※ Option: -J1:VH(J.S.T) connector type.

<PIN CONNECTION>

CN1		CN2		CN3	
Pin No.	Input	Pin No.	Output	Pin No.	Output
1	AC(L)	1 to 6	+V	1 to 7	-V
2					
3	AC(N)				
4					
5	FG				

※ Keep drawing current per pin below 5A for CN2, CN3.

- ※ Tolerance : ± 1 [± 0.04]
- ※ Weight : 370g max (with chassis & cover : 600g max)
- ※ PCB material : CEM3
- ※ Optional chassis and cover material : Electric galvanizing steel board.
- ※ Dimensions in mm, []=inches
- ※ Mounting torque (Mounting hole of chassis) : $1.5N \cdot m$ (16kgf · cm) max

Connector type

CN4 Option (Mfr:J.S.T)

PIN No.	Contents
1	RC(+)
2	RC(-)

Barrier strip type

Model B2B-XH-A
Mating Connector (Terminal)
XHP-2
(BXH-001T-P0.6
or SXH-001T-P0.6)

LMA240F

LM A 240 F -□ -□
 ① ② ③ ④ ⑤ ⑥

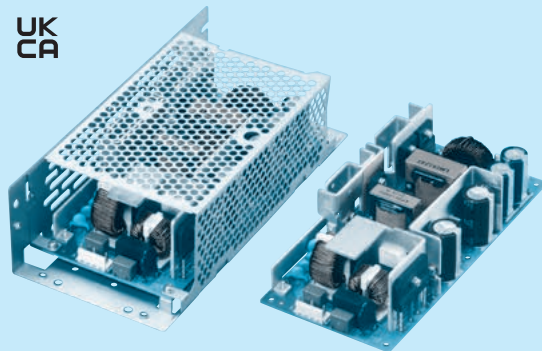

Example recommended EMI/EMC filter
NAM-06-101



High voltage pulse noise type : NAP series
 Low leakage current type : NAM series
 * A higher current rating EMI/EMC filter may be recommended in view of the other devices that could be connected in parallel with the power supply.

- ① Series name
- ② Single output
- ③ Output wattage
- ④ Universal input
- ⑤ Output voltage
- ⑥ Optional *1
- C : with Coating
- G : Low leakage current
- H : with the function to be acceptable to output peak current
- J1 : VH(J.S.T.)connector type
- R : with Remote ON/OFF
- S : with Chassis
- SN : with Chassis & cover
- P : Setting in the overcurrent protection rating

This power supply is manufactured by SMD technology. The stress to P.C.B like twisting or bending causes the defect of the unit, so handle the unit with care.
 *Make sure necessary tests will be carried out on your end equipment with the power supply installed in accordance with any required EMC/EMI regulations.

MODEL	LMA240F-24-Y	LMA240F-24-HY
MAX OUTPUT WATTAGE[W]	300	300 (480) *2
DC OUTPUT	Convection	24V 10A
	Forced air	24V 12.5A
		24V 12.5A (20A) *2

SPECIFICATIONS

	MODEL	LMA240F-24-Y	LMA240F-24-HY	
INPUT	VOLTAGE[V]	AC85 - 264 1 φ (Refer to "Derating" ,Instruction Manual 1 and 3)		
	CURRENT[A]	ACIN 100V	3.9typ (Io=100%)	
		ACIN 200V	1.8typ (Io=100%)	
	FREQUENCY[Hz]	50 / 60 (47 - 63)		
	EFFICIENCY[%]	ACIN 100V	86.0typ (Io=100%)	
		ACIN 200V	88.0typ (Io=100%)	
	POWER FACTOR	ACIN 100V	0.99typ (Io=100%)	
		ACIN 200V	0.95typ (Io=100%)	
	INRUSH CURRENT[A]	ACIN 100V	15 / 30typ (Io=100%) (Primary inrush current /Secondary inrush current) (More than 3 sec. to re-start)	
		ACIN 200V	30 / 30typ (Io=100%) (Primary inrush current /Secondary inrush current) (More than 3 sec. to re-start)	
LEAKAGE CURRENT[ma]	0.15 / 0.40max (ACIN 100V / 240V 60Hz, Io=100%, According to IEC60601-1)			
OUTPUT	VOLTAGE[V]	24	24	
	CURRENT[A]	Convection	10	10 (Peak 20) *2
		Forced air	12.5	12.5 (Peak 20) *2
	LINE REGULATION[mV] *7	96max		
	LOAD REGULATION[mV] *7	150max		
	RIPPLE[mVp-p] *3	0 to +50°C	120max	120max
		-10 - 0°C	160max	160max
	RIPPLE NOISE[mVp-p]*3	0 to +50°C	150max	150max
		-10 - 0°C	180max	180max
	TEMPERATURE REGULATION[mV]	0 to +50°C	240max	240max
		-10 to +50°C	290max	290max
	DRIFT[mV] *4	96max		
	START-UP TIME[ms]	350typ (ACIN 100V, Io=100%)		
	HOLD-UP TIME[ms] *9	20typ (ACIN 100V, Io=100%)		
OUTPUT VOLTAGE ADJUSTMENT RANGE[V]	19.20 to 27.50			
OUTPUT VOLTAGE SETTING[V]	24.00 to 24.96			
PROTECTION CIRCUIT AND OTHERS	OVERCURRENT PROTECTION	Works over 105% of rating (works over 101% of peak current at option -H) and recovers automatically		
	OVERVOLTAGE PROTECTION[V]	27.60 to 33.60		
	OPERATING INDICATION	Not provided		
	REMOTE SENSING	Not provided		
ISOLATION	REMOTE ON/OFF	Option (Required external power source.)		
	INPUT-OUTPUT-RC *6	AC4,000V 1minute, Cutoff current = 10mA, DC500V 50MΩ min (At Room Temperature) 2MOOP		
	INPUT-FG	AC2,000V 1minute, Cutoff current = 10mA, DC500V 50MΩ min (At Room Temperature) 1MOOP		
	OUTPUT-RC-FG *6	AC500V 1minute, Cutoff current = 25mA, DC500V 50MΩ min (At Room Temperature)		
	OUTPUT-RC *6	AC100V 1minute, Cutoff current = 25mA, DC100V 10MΩ min (At Room Temperature)		
ENVIRONMENT	OPERATING TEMP.,HUMID.AND ALTIITUDE *5	-10 to +70°C, 20 - 90%RH (Non condensing), (Refer to "Derating", Instruction Manual 3) 3,000m (10,000feet) max		
	STORAGE TEMP.,HUMID.AND ALTIITUDE	-20 to +75°C, 20 - 90%RH (Non condensing), 9,000m (30,000feet) max		
	VIBRATION	10 - 55Hz, 19.6m/s ² (2G), 3minutes period, 60minutes each along X, Y and Z axis		
SAFETY AND NOISE REGULATIONS	IMPACT	196.1m/s ² (20G), 11ms, once each X, Y and Z axis		
	AGENCY APPROVALS (AT ONLY AC input)	ANSI/AAMI ES60601-1, EN60601-1 3rd, Complies with IEC60601-1-2 4th Ed.		
	CONDUCTED NOISE	Complies with FCC-B, VCCI-B, CISPR22-B, EN55011-B, EN55022-B		
OTHERS	HARMONIC ATTENUATOR	Complies with IEC61000-3-2 (Class A) *8		
	CASE SIZE/WEIGHT	84 X 46 X 180mm [3.31 X 1.81 X 7.09 inches] (W X H X D) / 540g max (with chassis & cover : 860g max)		
	COOLING METHOD	Convection / Forced air (Refer to "Derating", Instruction Manual 3) *5		

*1 Specification is changed at option, refer to Instruction Manual.

*2 Peak loading for 10sec. And Duty 40% max.
 () means peak current. There is a possibility that an internal device is damaged when the specification is exceeded.

*3 This is the value that measured on measuring board with capacitor of 22 μF at 150mm from output terminal.
 Measured by 20MHz oscilloscope or Ripple-Noise meter (Equivalent

to KEISOKU-GIKEN: RM103).

*4 Drift is the change in DC output for an eight hour period after a half-hour warm-up at 25°C, with the input voltage held constant at the rated input/output.

*5 Derating is required.

*6 Applicable when remote control (optional) is added.

*7 Please contact us about dynamic load and input response.

*8 Please contact us about another class.

* To meet the specifications. Do not operate over-loaded condition.

* Parallel operation is not possible.

* Derating is required when operated with chassis and cover.

* Sound noise may be generated by power supply in case of pulse load.

Block diagram

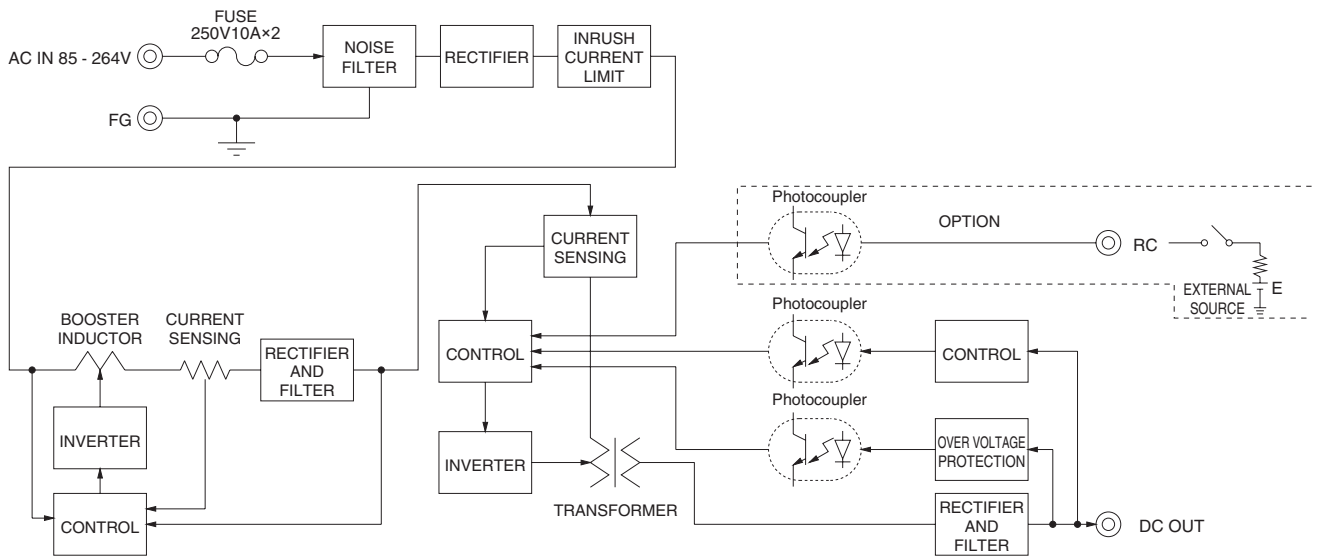

External view

※ External size of option is different from standard model.

Standard type

Chassis and cover type

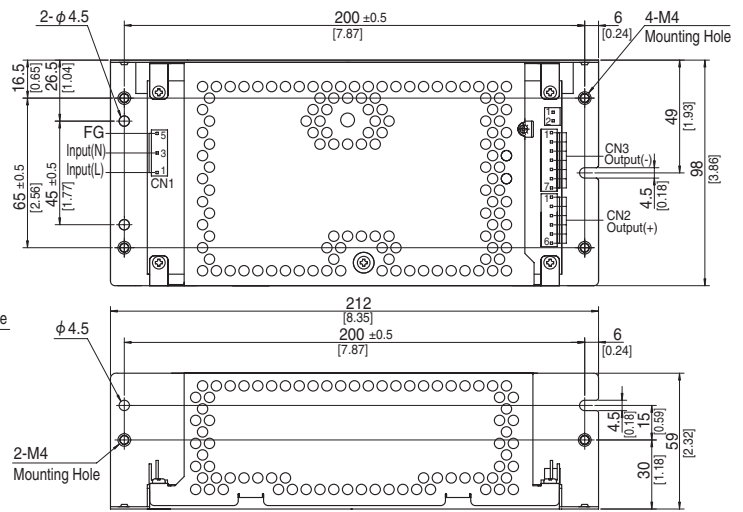
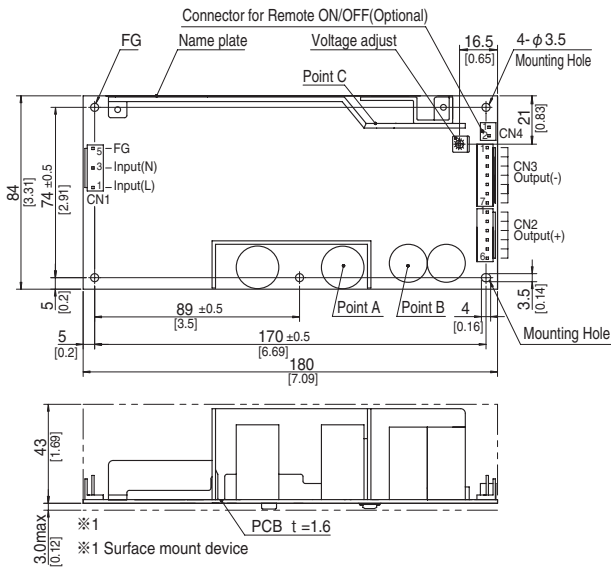

- ※ 5 Mounting holes are existing.
- ※ The back side of P.C.B. of the power supply is assembled some SMDs.
Be attention not to bump against the attached area by vibration.
- ※ Use the spacer of 8mm length or more regarding insulation.
And do not use press-fitting bush.
- ※ Point A, Point B, Point C are thermometry points.

I/O Connector	Mating connector	Terminal
CN1	1-1123724-3	Chain 1123721-1
		Loose 1318912-1
CN2	1-1123723-6	Chain 1123721-1
		Loose 1318912-1
CN3	1-1123723-7	Chain 1123721-1
		Loose 1318912-1

(Mfr:Tyco Electronics)

- ※ I/O Connector is Mfr. Tyco Electronics
- ※ Option:-J1:VH(J.S.T) connector type.

<PIN CONNECTION>

CN1		CN2		CN3	
Pin No.	Input	Pin No.	Output	Pin No.	Output
1	AC(L)	1 to 6	+V	1 to 7	-V
2					
3	AC(N)				
4					
5	FG				

※ Keep drawing current per pin below 5A for CN2,CN3.

- ※ Tolerance : ± 1 [± 0.04]
- ※ Weight : 540g max (with chassis & cover : 860g max)
- ※ PCB material : CEM3
- ※ Optional chassis and cover material : Electric galvanizing steel board.
- ※ Dimensions in mm, [] =inches
- ※ Mounting torque (Mounting hole of chassis) : $1.5N \cdot m$ (16kgf · cm) max

Connector type

CN4 Option (Mfr:J.S.T)

PIN No.	Contents
1	RC(+)
2	RC(-)

Barrier strip type

Model B2B-XH-A
Mating Connector (Terminal)
XHP-2
(BXH-001T-P0.6
or SXH-001T-P0.6)

Assembling and Installation Method

Installation method

■ This power supply is manufactured by SMD technology. The stress to P.C.B like twisting or bending causes the defect of the unit, so handle the unit with care.

■ In case of metal chassis, keep the distance between d1 & d2 for to insulate between lead of component and metal chassis, use the spacer of 8mm or more between d1. If it is less than d1 & d2, insert the insulation sheet between power supply and metal chassis.

■ There is a possibility that it is not possible to cool enough when the power supply is used by the sealing up space as showing in right figure. Please use it after confirming the temperature of point A and point B of Instruction Manual 3.

■ (F) mounting is not possible when unit is with case cover, but if need to operate unit by (F) positioning with case cover, temperature / load derating is necessary. For more details, please contact our sales or engineering departments.

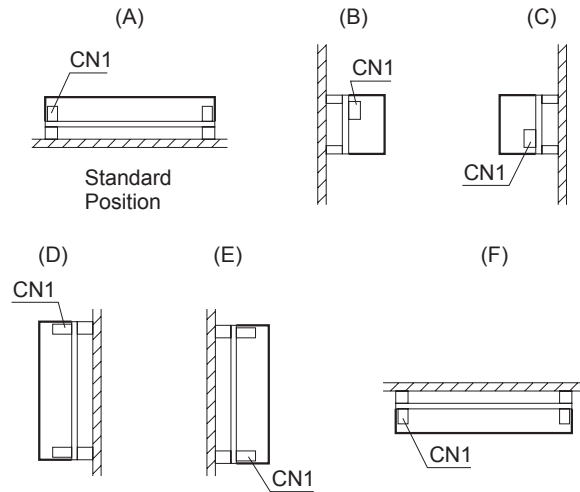
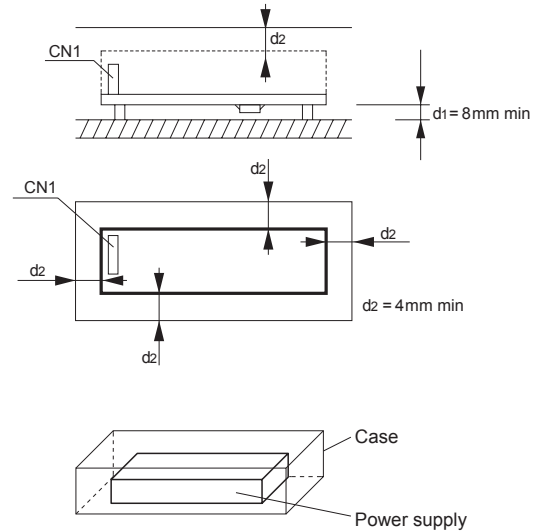

Mounting screw

■ The mounting screw should be M3. The hatched area shows the allowance of metal parts for mounting.

● LMA100F, LMA150F

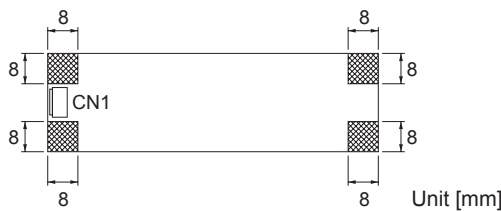

● LMA240F

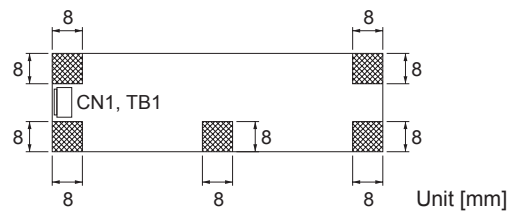

■ If metallic fittings are used on the component side of the board, ensure there is no contact with surface mounted components.
 ■ This product uses SMD technology. Please avoid the PCB installation method which includes the twisting stress or the bending stress.
 * Recommendation to electrically connect FG to metal chassis for reducing noise.

Derating

● Derating curve for input voltage

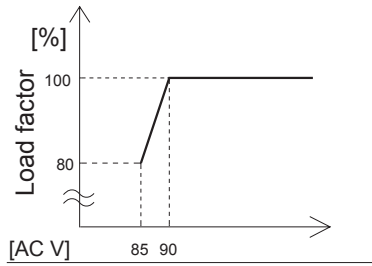

● LMA100F Ambient temperature derating curve (Reference value)

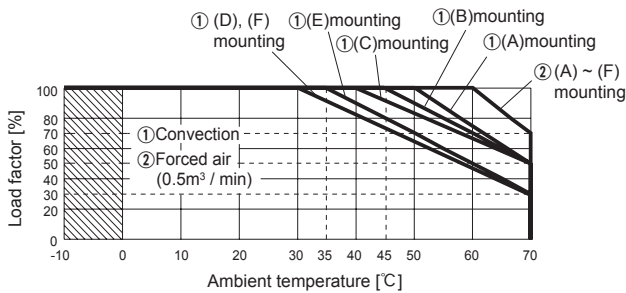

● LMA150F Ambient temperature derating curve (Reference value)

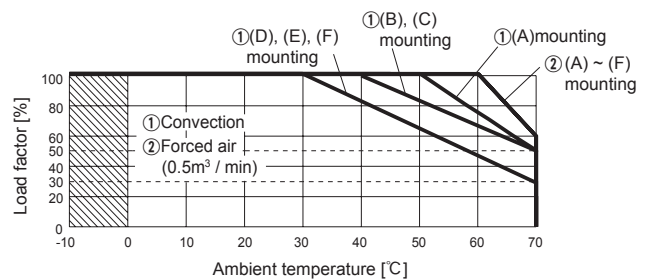

● LMA240F Ambient temperature derating curve (Reference value)

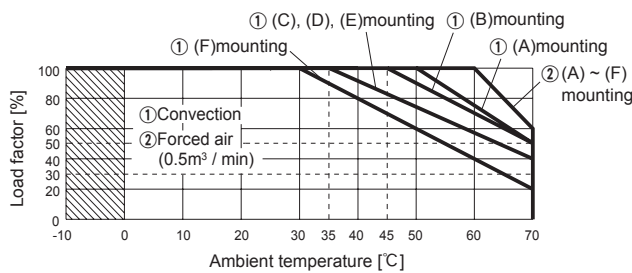

Output voltage	Output power[W]	
	①Convection	②Forced air
24V	240.0	300.0

■ The operative ambient temperature is different by with / without chassis cover or mounting position.

Note: In the hatched area, the specification of Ripple, Ripple Noise is different from other area.

■ Make sure the temperature at point A and point B is less than the temperatures shown in Instruction Manual 3.

■ The ambient temperature should be measured 5 to 10 cm away from the power supply so that it won't be influenced by the heat from the power supply. Please consult us for more details.

Instruction Manual

◆ It is necessary to read the "Instruction Manual" and "Before using our product" before you use our product.

Instruction Manual <https://www.cosel.co.jp/redirect/catalog/en/LMA/>
 Before using our product <https://en.cosel.co.jp/technical/caution/index.html>

LMA



NOTICE



Basic Characteristics Data

Model	Circuit method	Switching frequency [kHz]	Input current *1 [A]	Inrush current protection	PCB/Pattern			Series/Parallel operation availability	
					Material	Single sided	Double sided	Series operation	Parallel operation
LMA100F	Active filter	60	1.4	Thermistor	CEM-3		Yes	Yes	No
	Forward converter	130							
LMA150F	Active filter	60	2.0	Thermistor	CEM-3		Yes	Yes	No
	Forward converter	130							
LMA240F	Active filter	60	3.9	SCR	CEM-3		Yes	Yes	No
	Forward converter	130							

*1 The value of input current is at ACIN 100V and rated load.



UMA-series

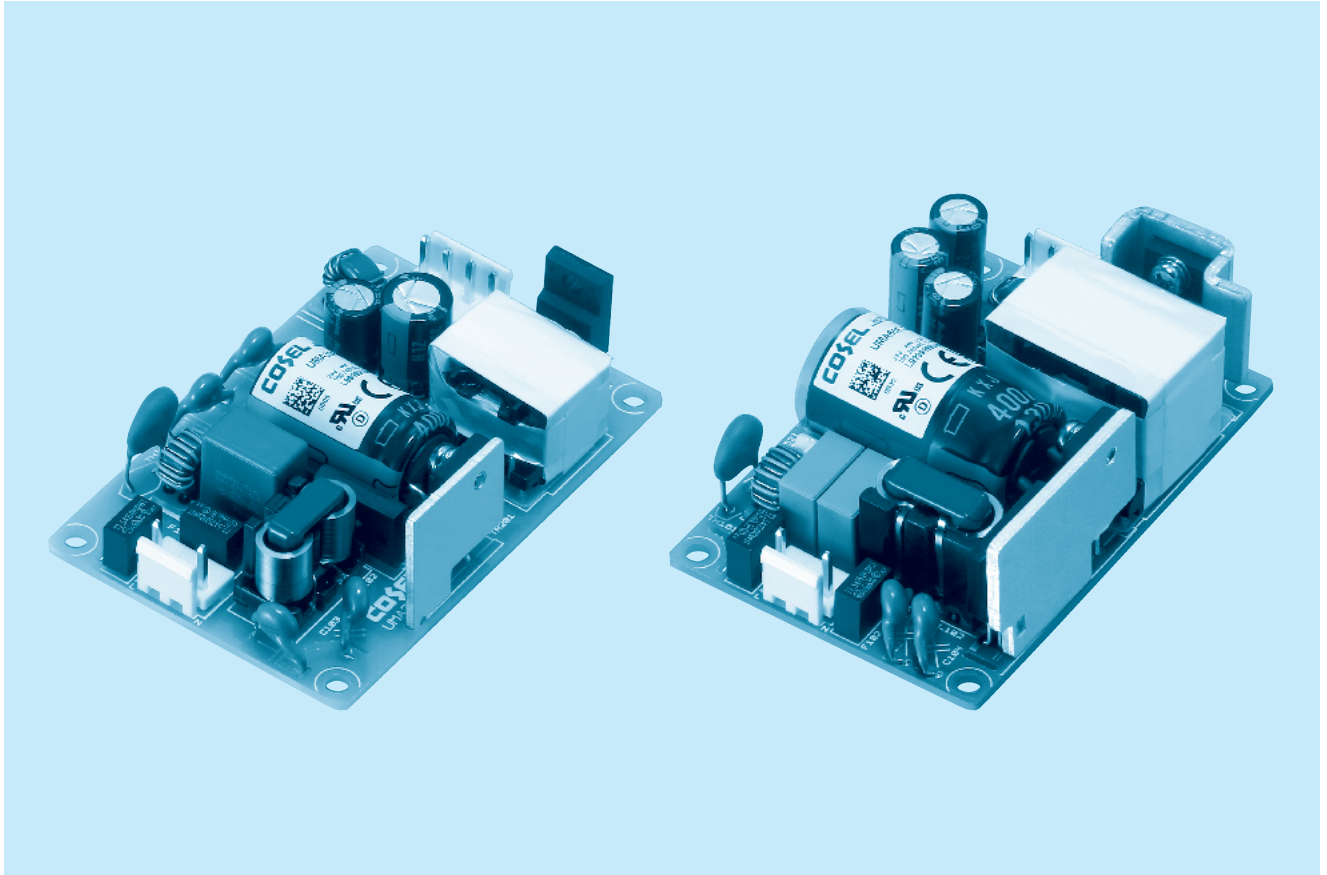

■ Feature

For medical electric equipment
 Medical Isolation Grade 2MOPP
 4kV isolation
 Suitable for BF application
 Low leakage current
 2"× 3" standard footprint
 Economical design

■ Safety agency approvals

ANSI/AAMI ES60601-1, EN60601-1 3rd,
 C-UL (CAN/CSA-C22.2 No.60601-1),
 UL62368-1, EN62368-1,
 C-UL (CAN/CSA-C22.2 No.62368-1),
 Complies with EN60335

■ CE marking

Low Voltage Directive
 RoHS Directive

■ UKCA marking

Electrical Equipment Safety Regulations
 RoHS Regulations

■ 5-year warranty (See Instruction Manual)

■ EMI

Complies with CISPR11 classB, CISPR32 classB, EN55011-B,
 EN55032-B, FCC Part15 classB and FCC Part18 classB

■ EMS Compliance : EN61204-3, EN61000-6-2 IEC60601-1-2 (2014), EN60601-1-2 (2015)

EN61000-4-2
 EN61000-4-3
 EN61000-4-4
 EN61000-4-5
 EN61000-4-6
 EN61000-4-8
 EN61000-4-11

UMA30F

① **UM** ② **A** ③ **30** ④ **F** ⑤ **-□** ⑥ **-□**

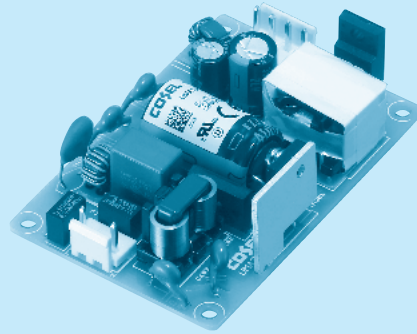

- ① Series name
- ② Single output
- ③ Output wattage
- ④ Universal input
- ⑤ Output voltage
- ⑥ Optional *5
E : IEC Class II
T : Terminal block
Y : with Potentiometer

*Make sure necessary tests will be carried out on your end equipment with the power supply installed in accordance with any required EMC/EMI regulations.

MODEL	UMA30F-5	UMA30F-12	UMA30F-15	UMA30F-24	UMA30F-36	UMA30F-48
MAX OUTPUT WATTAGE[W]	15	30	30	31.2	30.6	31.2
DC OUTPUT	5V 3A	12V 2.5A	15V 2A	24V 1.3A	36V 0.85A	48V 0.65A

SPECIFICATIONS

	MODEL	UMA30F-5	UMA30F-12	UMA30F-15	UMA30F-24	UMA30F-36	UMA30F-48	
INPUT	VOLTAGE[V]	AC85 - 264 1φ						
	CURRENT[A]	ACIN 115V	0.35	0.7				
		ACIN 230V	0.15	0.3				
	FREQUENCY[Hz]	50/60 (47-63)						
	EFFICIENCY[%]	ACIN 115V	81typ	86typ	86typ	88typ	88typ	88typ
		ACIN 230V	80typ	87typ	87typ	89typ	89typ	89typ
	INRUSH CURRENT[A]	ACIN 115V	25typ					
		ACIN 230V	50typ					
LEAKAGE CURRENT[μA]	ACIN 264V	200max						
TOUCH CURRENT[μA]	ACIN 264V	75max						
OUTPUT	VOLTAGE[V]	5	12	15	24	36	48	
	CURRENT[A]	3	2.5	2	1.3	0.85	0.65	
	WATTAGE[W]	15	30	30	31.2	30.6	31.2	
	LINE REGULATION[mV] *1	20max	48max	60max	96max	144max	192max	
	LOAD REGULATION[mV] *1	100max	120max	120max	150max	240max	240max	
	RIPPLE NOISE [mVp-p] *2	150 (Bandwidth 20MHz)						
	TEMPERATURE REGULATION[mV]	0~+50°C 100max						
	START-UP TIME[ms]	ACIN 115V	40typ					
		ACIN 230V	40typ					
	HOLD-UP TIME[ms]	ACIN 115V	20typ					
		ACIN 230V	100typ					
	OUTPUT VOLTAGE ADJUSTMENT RANGE[V]	Fixed ("Y"option is available for adjusting output voltage between ±10%)						
OUTPUT VOLTAGE SETTING[V]	4.90 to 5.30	11.50 to 12.50	14.40 to 15.60	23.00 to 25.00	34.50 to 37.50	46.00 to 50.00		
PROTECTION CIRCUIT AND OTHERS	OVERCURRENT PROTECTION [A]	Works over 105% of rating and recovers automatically						
	OVERVOLTAGE PROTECTION[V]	5.75 to 7.00	13.80 to 16.80	17.25 to 21.00	27.60 to 33.60	41.40 to 50.40	55.20 to 67.20	
ISOLATION	INPUT-OUTPUT	AC4,000V 1minute, DC500V 100MΩ min (At Room Temperature) 2MOPP						
	INPUT-FG	AC2,000V 1minute, DC500V 100MΩ min (At Room Temperature) 1MOPP						
	OUTPUT-FG	AC2,000V 1minute, DC500V 100MΩ min (At Room Temperature) 1MOPP						
ENVIRONMENT	OPERATING TEMP., HUMID.*3	-20 to +70°C, 20 - 90%RH (Non condensing)						
	STORAGE TEMP., HUMID.	-20 to +75°C, 20 - 90%RH (Non condensing)						
	VIBRATION	10 - 55Hz, 19.6m/s ² (2G) , 3minutes period, 60minutes each along X, Y and Z axis						
	IMPACT	196.1m/s ² (20G) , 11ms, once each X, Y and Z axis						
SAFETY AND EMC	AGENCY APPROVALS	ANSI/AAMI ES60601-1, EN60601-1 3rd, C-UL (equivalent to CAN/CSA-C22.2 No.60601-1) , UL62368-1, EN62368-1, C-UL (equivalent to CAN/CSA-C22.2 No.62368-1) , Complies with EN60335-1						
	EMC EMISSION	Complies with CISPR11 classB, CISPR32 classB, EN55011-B, EN55032-B, FCC Part15 classB and FCC Part18 classB						
	EMC IMMUNITY	Complies with EN61000-4-2, 3, 4, 5, 6, 8, 11						
	HARMONIC ATTENUATOR*6	Complies with IEC61000-3-2 (Class A) No built-in active PFC						
OTHERS	CASE SIZE/WEIGHT *7	50.8×21.7×76.2mm [2.0×0.85×3.0 inches] (WXHXD) / 80g max						
	COOLING METHOD	Convection						
WARRANTY	WARRANTY *4	5 years (subject to the operating conditions)						

*1 Consult us about dynamic load and input response. Measure the output voltage by using the average mode of the tester to deal with the burst operation at low (Io=0~20%Atyp) load.

*2 This is the result of measurement of the testing board with capacitors of 47μF and 0.1μF placed at 150 mm from the output terminals by a 20MHz oscilloscope or a ripple-noise meter equivalent to Keisoku-GikenRM104.

When the load factor is low (Io=0~20%Atyp), the switching power loss is reduced by burst operation, which will cause ripple noise to go beyond the specifications.

*3 Output power derating is required. Refer to "Derating"

*4 Consult us about details.

*5 The listed options may affect the published standard specifications. Please contact us for detailed product specifications and safety approvals.

*6 Please contact us about another class. When two or more units are operating it may not comply with the IEC61000-3-2. Please contact us for details.

*7 Dimensions below PCB are not included.

* All parameters not specially mentioned are measured at ACIN 230V, rated load and 25°C of ambient temperature.

* Do not use the power supply in overcurrent conditions or in unspecified input voltage ranges. Otherwise the internal components may be damaged.

* Parallel operation is not possible with this model.

* Acoustic noise may be heard from the power supply when used for pulse load.

External view

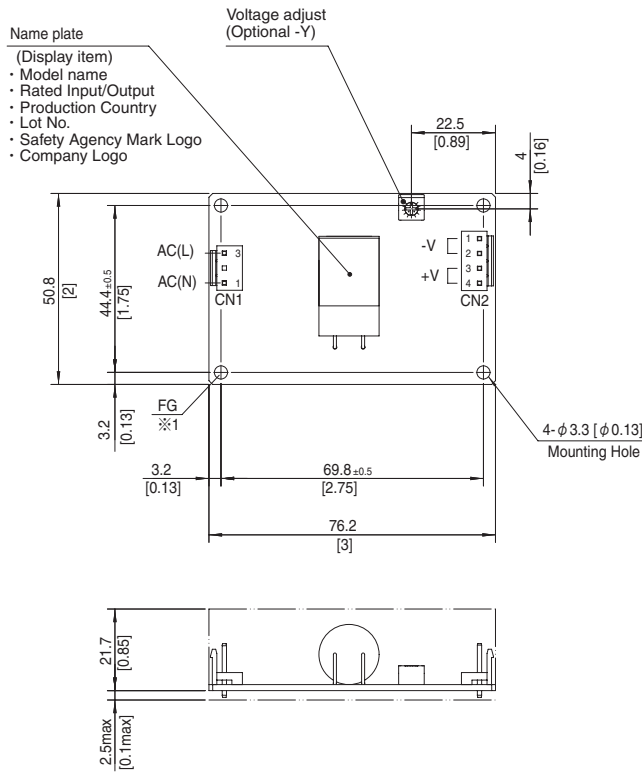

Mating connector and terminal of CN1, CN2

I/O Connector	Mating Connector	Terminal	Mfr.
CN1	B2P3-VH	Reel : SVH-21T-P1.1 Loose piece : BVH-21T-P1.1	J.S.T.
CN2	B4P-VH	Chain : SVH-21T-P1.1 Loose piece : BVH-21T-P1.1	J.S.T.

<Pin Assignments>

CN1		CN2	
Pin No.	Input	Pin No.	Output
1	AC(N)	1, 2	-V
2		3, 4	+V
3	AC(L)		

- ※ Dimensions in mm, [] =inches
- ※ Tolerance : ±1 [±0.04]
- ※ Weight : 80g max
- ※ PCB Material/thickness : CEM-3/1.6 [0.06]
- ※1 The mounting hole is for FG connection.
The mounting hole in the -E option is not for FG connection.

Derating Curve

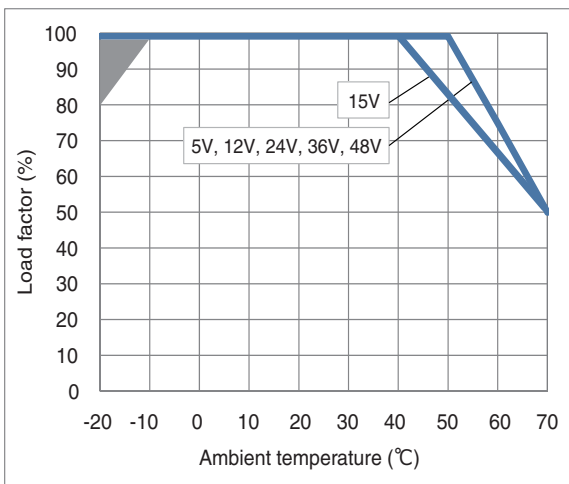

*The shaded area is the derating required at start-up.

Fig.1 Derating curve depending on ambient temperature

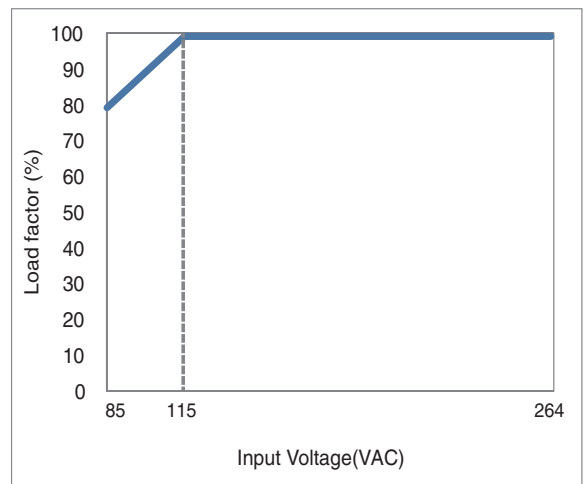
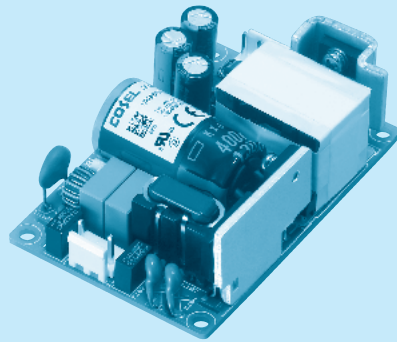
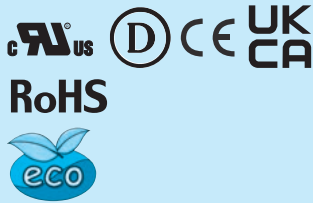

Fig.2 Derating curve depending on input voltage

■ The ambient temperature should be measured 5 to 10 cm away from the power supply so that it won't be influenced by the heat from the power supply. Please consult us for more details.

UMA60F

① **UM** ② **A** ③ **60** ④ **F** ⑤ **-□** ⑥ **-□**



- ① Series name
- ② Single output
- ③ Output wattage
- ④ Universal input
- ⑤ Output voltage
- ⑥ Optional *5
E : IEC Class II
T : Terminal block
Y : with Potentiometer

*Make sure necessary tests will be carried out on your end equipment with the power supply installed in accordance with any required EMC/EMI regulations.

MODEL	UMA60F-5	UMA60F-7R5	UMA60F-12	UMA60F-15	UMA60F-24	UMA60F-36	UMA60F-48
MAX OUTPUT WATTAGE[W]	30	41.25	54	52.5	60	61.2	60
DC OUTPUT	5V 6A	7.5V 5.5A	12V 4.5A	15V 3.5A	24V 2.5A	36V 1.7A	48V 1.25A

SPECIFICATIONS

	MODEL	UMA60F-5	UMA60F-7R5	UMA60F-12	UMA60F-15	UMA60F-24	UMA60F-36	UMA60F-48	
INPUT	VOLTAGE[V]	AC85 - 264 1φ							
	CURRENT[A]	ACIN 115V	0.7	1.0	1.4				
		ACIN 230V	0.3	0.5	0.7				
	FREQUENCY[Hz]	50/60 (47-63)							
	EFFICIENCY[%]	ACIN 115V	80typ	84typ	87typ	86typ	88typ	89typ	89typ
		ACIN 230V	80typ	85typ	88typ	87typ	90typ	91typ	91typ
	INRUSH CURRENT[A]	ACIN 115V	25typ						
		ACIN 230V	50typ						
LEAKAGE CURRENT[μA]	ACIN 264V	200max							
TOUCH CURRENT[μA]	ACIN 264V	75max							
OUTPUT	VOLTAGE[V]	5	7.5	12	15	24	36	48	
	CURRENT[A]	6	5.5	4.5	3.5	2.5	1.7	1.25	
	WATTAGE[W]	30	41.25	54	52.5	60	61.2	60	
	LINE REGULATION[mV] *1	20max	36max	48max	60max	96max	144max	192max	
	LOAD REGULATION[mV] *1	100max	120max	120max	120max	150max	240max	240max	
	RIPPLE NOISE [mVp-p] *2	Io=100%	150 (Bandwidth 20MHz)						
	TEMPERATURE REGULATION[mV]	0~+50°C	100max	100max	120max	180max	240max	360max	480max
	START-UP TIME[ms]	ACIN 115V	40typ						
		ACIN 230V	40typ						
	HOLD-UP TIME[ms]	ACIN 115V	20typ						
ACIN 230V		100typ							
OUTPUT VOLTAGE ADJUSTMENT RANGE[V]	Fixed (*Y*option is available for adjusting output voltage between ±10%)								
OUTPUT VOLTAGE SETTING[V]	4.90 to 5.30	7.20 to 7.80	11.50 to 12.50	14.40 to 15.60	23.00 to 25.00	34.50 to 37.50	46.00 to 50.00		
PROTECTION CIRCUIT AND OTHERS	OVERCURRENT PROTECTION [A]	Works over 105% of rating and recovers automatically							
	OVERVOLTAGE PROTECTION[V]	5.75 to 7.00	8.63 to 10.50	13.80 to 16.80	17.25 to 21.00	27.60 to 33.60	41.40 to 50.40	55.20 to 67.20	
ISOLATION	INPUT-OUTPUT	AC4,000V 1minute, DC500V 100MΩ min (At Room Temperature) 2MOPP							
	INPUT-FG	AC2,000V 1minute, DC500V 100MΩ min (At Room Temperature) 1MOPP							
	OUTPUT-FG	AC2,000V 1minute, DC500V 100MΩ min (At Room Temperature) 1MOPP							
ENVIRONMENT	OPERATING TEMP., HUMID.*3	-20 to +70°C, 20 - 90%RH (Non condensing)							
	STORAGE TEMP., HUMID.	-20 to +75°C, 20 - 90%RH (Non condensing)							
	VIBRATION	10 - 55Hz, 19.6m/s ² (2G) , 3minutes period, 60minutes each along X, Y and Z axis							
	IMPACT	196.1m/s ² (20G) , 11ms, once each X, Y and Z axis							
SAFETY AND EMC	AGENCY APPROVALS	ANSI/AAMI ES60601-1, EN60601-1 3rd, C-UL (equivalent to CAN/CSA-C22.2 No.60601-1) , UL62368-1, EN62368-1, C-UL (equivalent to CAN/CSA-C22.2 No.62368-1) , Complies with EN60335-1							
	EMC EMISSION	Complies with CISPR11 classB, CISPR32 classB, EN55011-B, EN55032-B, FCC Part15 classB and FCC Part18 classB							
	EMC IMMUNITY	Complies with EN61000-4-2, 3, 4, 5, 6, 8, 11							
	HARMONIC ATTENUATOR*6	Complies with IEC61000-3-2 (Class A) No built-in active PFC							
OTHERS	CASE SIZE/WEIGHT *7	50.8×24.2×76.2mm [2.0×0.95×3.0 inches] (W×H×D) / 120g max							
	COOLING METHOD	Convection							
WARRANTY	WARRANTY *4	5 years (subject to the operating conditions)							

*1 Consult us about dynamic load and input response. Measure the output voltage by using the average mode of the tester to deal with the burst operation at low (Io=0~20%Atyp) load.

*2 This is the result of measurement of the testing board with capacitors of 47μF and 0.1μF placed at 150 mm from the output terminals by a 20MHz oscilloscope or a ripple-noise meter equivalent to Keisoku-GikenRM104. When the load factor is low (Io=0~20%Atyp), the switching power loss is reduced by burst operation, which will cause ripple noise to go beyond the specifications.

*3 Output power derating is required. Refer to "Derating"

*4 Consult us about details.

*5 The listed options may affect the published standard specifications. Please contact us for detailed product specifications and safety approvals.

*6 Please contact us about another class. When two or more units are operating it may not comply with the IEC61000-3-2. Please contact us for details.

*7 Dimensions below PCB are not included.

* All parameters not specially mentioned are measured at ACIN 230V, rated load and 25°C of ambient temperature.

* Do not use the power supply in overcurrent conditions or in unspecified input voltage ranges. Otherwise the internal components may be damaged.

* Parallel operation is not possible with this model.

* Acoustic noise may be heard from the power supply when used for pulse load.

External view

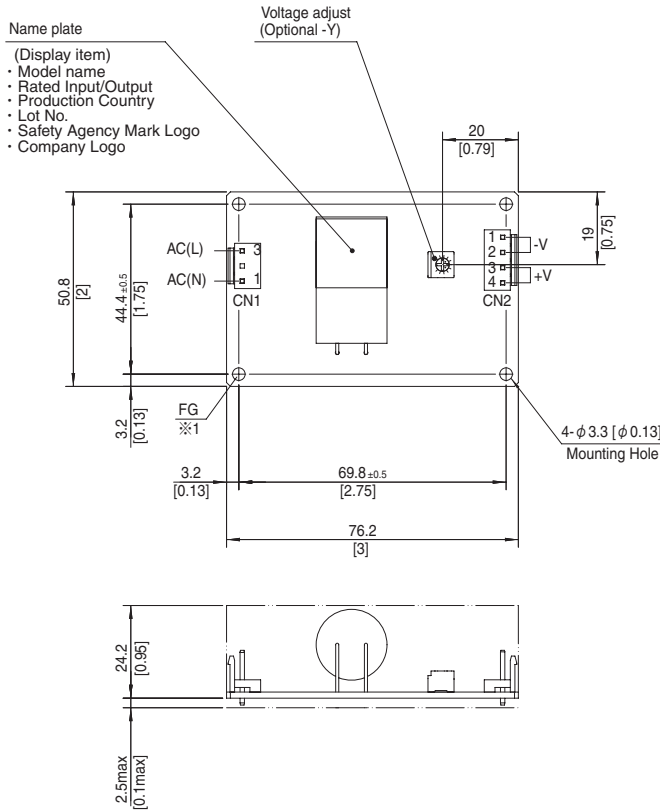

Mating connector and terminal of CN1, CN2

I/O Connector	Mating Connector	Terminal	Mr.
CN1	B2P3-VH	VHR-3N	J.S.T.
		Reel : SVH-21T-P1.1 Loose piece : BVH-21T-P1.1	
CN2	B4P-VH	VHR-4N	J.S.T.
		Chain : SVH-21T-P1.1 Loose piece : BVH-21T-P1.1	

<Pin Assignments>

CN1		CN2	
Pin No.	Input	Pin No.	Output
1	AC(N)	1, 2	-V
2	AC(L)	3, 4	+V
3			

- ※ Dimensions in mm, [] =inches
- ※ Tolerance : ±1 [±0.04]
- ※ Weight : 120g max
- ※ PCB Material/thickness : FR-4/1.6 [0.06]
- ※1 The mounting hole is for FG connection.
The mounting hole in the -E option is not for FG connection.

Derating Curve

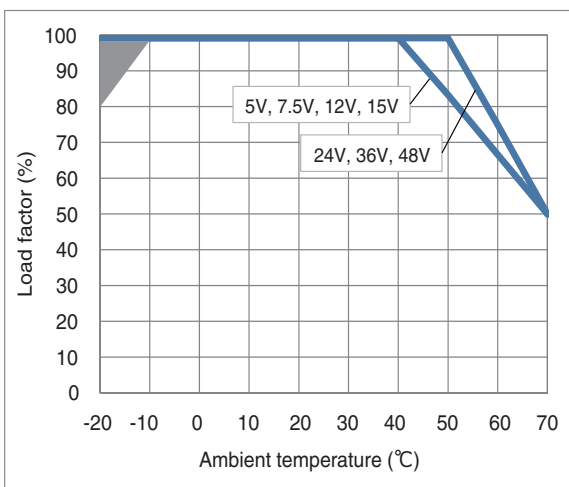

*The shaded area is the derating required at start-up.
Fig.1 Derating curve depending on ambient temperature

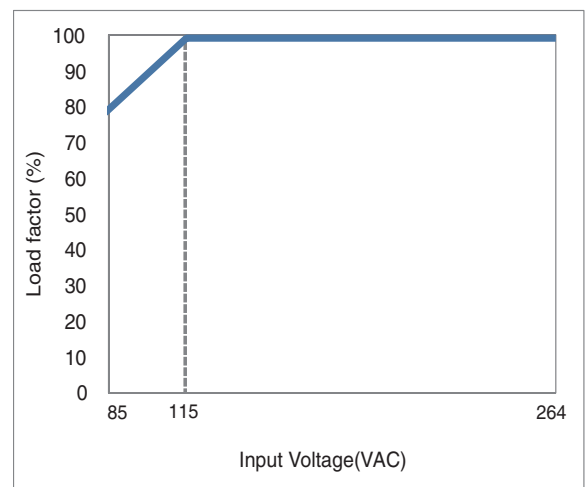
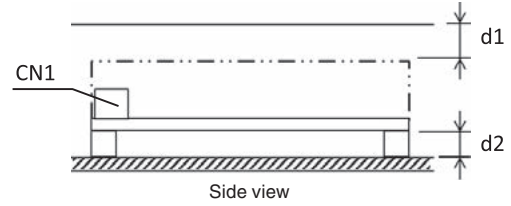

Fig.2 Derating curve depending on input voltage

■ The ambient temperature should be measured 5 to 10 cm away from the power supply so that it won't be influenced by the heat from the power supply. Please consult us for more details.

Assembling and Installation Method

■When the power supply is used with natural convection cooling, the standard mounting position is horizontal.



■AC voltage exists on the primary side. Therefore, in order to prevent electric shock, or to meet the leakage current requirements of the safety standard, you need to ensure the proper insulation distance.

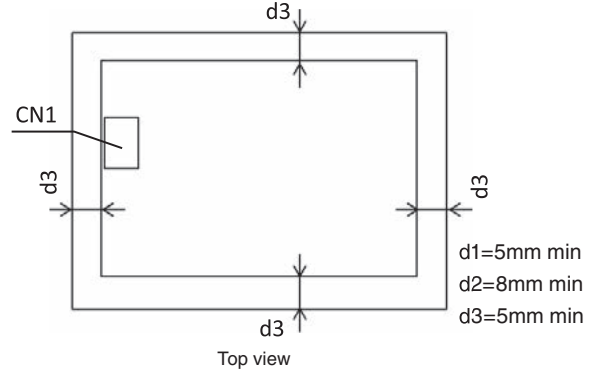

Mounting screw

- The mounting screws should be M3.
The hatched area indicates the proper area for mounting hardware.
- This power supply is manufactured by SMD technology.
Stress to the PCB such as twisting or bending may cause damage to the unit, please handle with care.

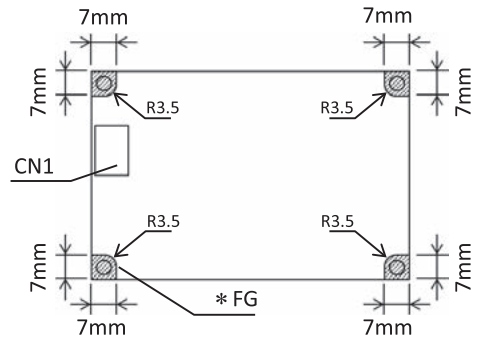

* Recommend to electrically connect FG to metal chassis for reducing noise.

Instruction Manual

■Please read the “Instruction Manual” and “Before using our product” before you use our product.

Instruction Manual <https://en.cosel.co.jp/product/powersupply/UMA/>
 Before using our product <https://en.cosel.co.jp/technical/caution/index.html>



Basic Characteristics Data

Model	Circuit method	Switching frequency [kHz]	Input current [A]	Rated input fuse	Inrush current protection circuit	PCB/Pattern			Parallel operation
						Material	Single sided	Double sided	
UMA30F	Flyback converter	20 to 125	0.7	250V 2.5A	Thermistor	CEM-3	Yes		No
UMA60F	Flyback converter	20 to 125	1.4	250V 2.5A	Thermistor	FR4		Yes	No

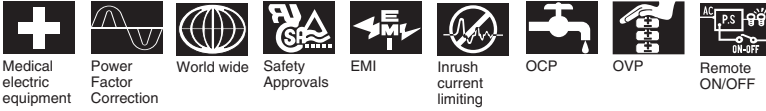

GMA-series

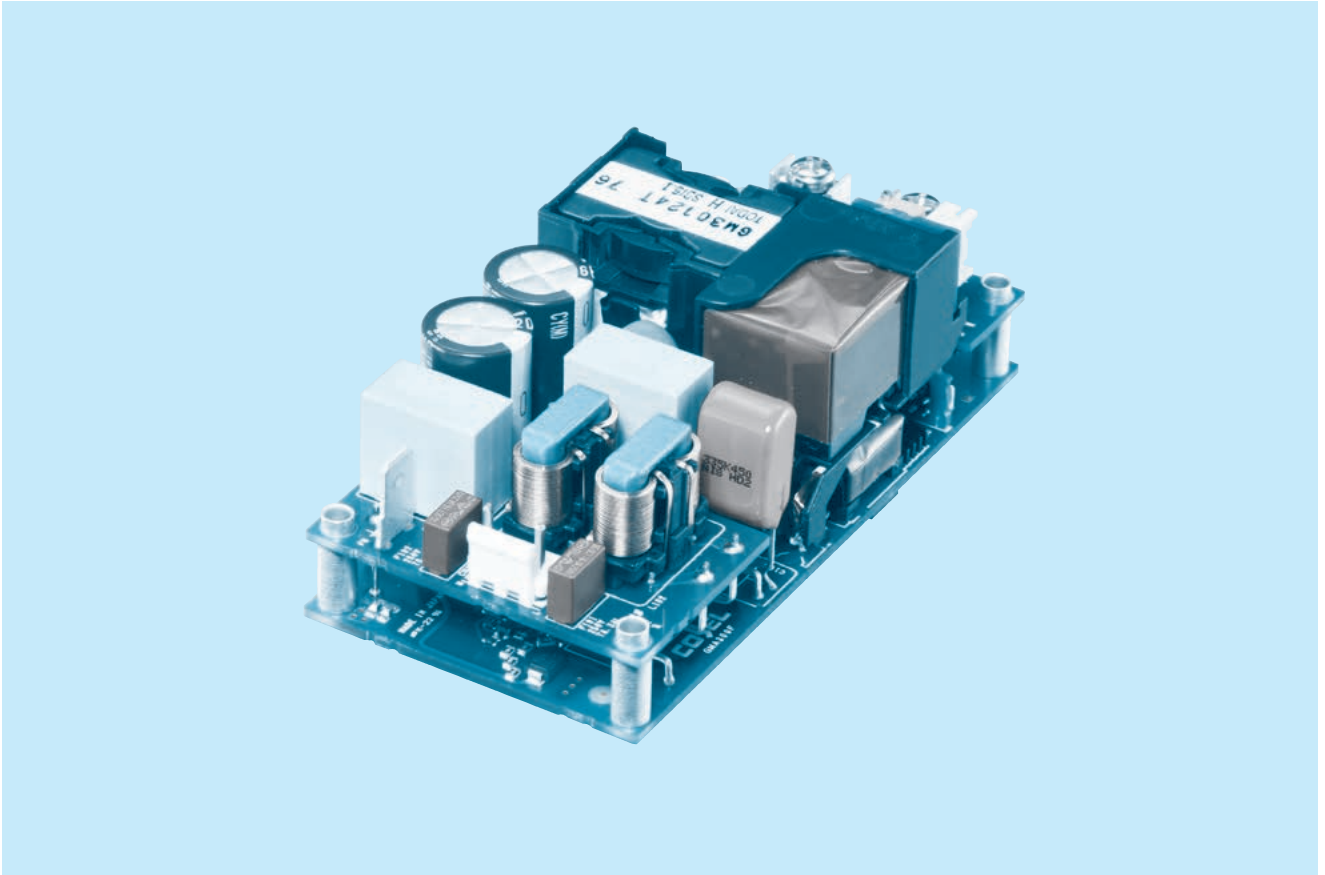

Feature

Wattage 300Wmax
 For medical electric equipment (ANSI/AAMI ES60601-1, EN60601-1 3rd, IEC60601-1-2 4th Ed.)
 Suitable for BF application (Output-FG : 1MOPP, Input-Output : 2MOPP)
 2"× 4" standard footprint
 With Remote ON/OFF (Optional)
 With AUX1 (12V 1A), AUX2 (5V 1A) (Optional)

Safety agency approvals

UL62368-1, ANSI/AAMI ES60601-1
 C-UL (CSA62368-1, CAN/CSA60601-1)
 EN62368-1, EN60601-1 3rd
 Complies with IEC60601-1-2 4th Ed.

5-year warranty (Refer to Instruction Manual)

CE marking

Low Voltage Directive
 RoHS Directive

UKCA marking

Electrical Equipment Safety Regulations
 RoHS Regulations

EMI

Complies with FCC-B, CISPR11-B, CISPR32-B, EN55011-B, EN55032-B, VCCI-B

EMS Compliance : EN61204-3, EN61000-6-2 IEC60601-1-2(2014), EN60601-1-2(2015)

EN61000-4-2
 EN61000-4-3
 EN61000-4-4
 EN61000-4-5
 EN61000-4-6
 EN61000-4-8
 EN61000-4-11

GMA300F

GM A 300 F -□□ -□
 ① ② ③ ④ ⑤ ⑥

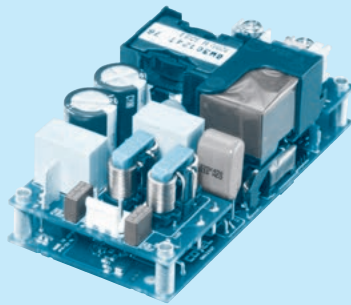

Example recommended EMI/EMC filter
EAC-06-472



High voltage pulse noise type : EAP series
 Low leakage current type : EAM series
 * A higher current rating EMI/EMC filter may be recommended in view of the other devices that could be connected in parallel with the power supply.

- ① Series name
- ② Single output
- ③ Output wattage
- ④ Universal input
- ⑤ Output voltage
- ⑥ Optional *6
- C : with Coating
- J1 : Input connector
VH (J.S.T.) connector type
- J3 : Horizontal input connector
VH (J.S.T.) connector type
- R3 : with Subfeatures
(5V1A AUX, 12V1A AUX, Remote ON/OFF)

Specification changes when options are added. Please refer to the instruction manual for more detail.

This power supply is manufactured using SMD technology. The stress to P.C.B like twisting or bending causes the defect of the unit, please handle the unit with care.
 *Make sure necessary tests will be carried out on your end equipment with the power supply installed in accordance with any required EMC/EMI regulations.

MODEL	GMA300F-12	GMA300F-24	GMA300F-48	GMA300F-56
MAX OUTPUT WATTAGE[W]	300	300	302.4	302.4
DC OUTPUT	12V 25A	24V 12.5A	48V 6.3A	56V 5.4A

SPECIFICATIONS

	MODEL	GMA300F-12	GMA300F-24	GMA300F-48	GMA300F-56	
INPUT	VOLTAGE[V]	AC85 - 264 1φ (Output derating is required at AC85V - 115V. See "Derating")				
	CURRENT[A]	ACIN 115V	3.3typ			
		ACIN 230V	1.8typ			
	FREQUENCY[Hz]	50 / 60 (45 - 66)				
	EFFICIENCY[%]	ACIN 115V	90typ	91typ	91typ	91typ
		ACIN 230V	92typ	93typ	93typ	93typ
	POWER FACTOR (Io=100%)	ACIN 115V	0.95typ			
		ACIN 230V	0.90typ			
	INRUSH CURRENT[A]	ACIN 115V	30typ (Io=100%) (At cold start, Ta=25°C)			
		ACIN 230V	60typ (Io=100%) (At cold start, Ta=25°C)			
LEAKAGE CURRENT[ma]	0.13 / 0.30max (ACIN 100/240V 60Hz, Io=100%, According to IEC60601-1)					
OUTPUT	VOLTAGE[V]	12	24	48	56	
	CURRENT[A]	25	12.5	6.3	5.4	
	LINE REGULATION[mV]	48max	96max	192max	192max	
	LOAD REGULATION[mV]	100max	150max	240max	240max	
	RIPPLE[mVp-p]	0 to +50°C	240max	240max	400max	400max
		-20 to 0°C	320max	320max	500max	500max
	RIPPLE NOISE[mVp-p]	0 to +50°C	300max	300max	500max	500max
		-20 to 0°C	360max	360max	580max	580max
	TEMPERATURE REGULATION[mV]	0 to +50°C	120max	240max	480max	480max
		-20 to +50°C	150max	290max	600max	600max
	DRIFT[mV]	48max	96max	192max	192max	
	START-UP TIME[ms]	400typ (ACIN 115V, Io=100%) *Start-up time is 900ms typ for less than 1minute of applying input again from turning off the input voltage.				
	HOLD-UP TIME[ms]	16typ (ACIN 115V, Io=85%) / 12typ (ACIN 115V, Io=100%)				
OUTPUT VOLTAGE ADJUSTMENT RANGE[V]	11.40 ~ 13.20		22.80 ~ 26.40		45.60 ~ 52.80	
OUTPUT VOLTAGE SETTING[V]	12.00 ~ 12.48		24.00 ~ 24.96		48.00 ~ 49.92	
PROTECTION CIRCUIT AND OTHERS	OVERCURRENT PROTECTION	Works over 105% of rating and recovers automatically				
	OVERVOLTAGE PROTECTION[V]	13.80 to 16.80	27.60 to 33.60	55.20 to 67.20	60.00 to 70.50	
	AUX1 (12V1A)	Optional				
	AUX2 (5V1A)	Optional				
REMOTE ON/OFF	Optional					
ISOLATION	INPUT-OUTPUT · RC · AUX	*7 AC4,000V 1minute, Cutoff current = 10mA, DC500V 50MΩ min (At Room Temperature) 2MOPP				
	INPUT-FG	AC2,000V 1minute, Cutoff current = 10mA, DC500V 50MΩ min (At Room Temperature) 1MOPP				
	OUTPUT · RC · AUX-FG	*7 AC1,500V 1minute, Cutoff current = 10mA, DC500V 50MΩ min (At Room Temperature) 1MOPP				
	OUTPUT-RC · AUX	*7 AC100V 1minute, Cutoff current = 25mA, DC100V 10MΩ min (At Room Temperature)				
ENVIRONMENT	OPERATING TEMP., HUMID. AND ALTITUDE	-20 to +70°C, 20 - 90%RH (Non condensing), 5,000m (16,000feet) max *3 *8				
	STORAGE TEMP., HUMID. AND ALTITUDE	-30 to +75°C, 20 - 90%RH (Non condensing), 9,000m (30,000feet) max				
	VIBRATION	10 - 55Hz, 19.6m/s ² (2G), 3minutes period, 60minutes each along X, Y and Z axis				
	IMPACT	196.1m/s ² (20G), 11ms, once each X, Y and Z axis				
SAFETY AND NOISE REGULATIONS	AGENCY APPROVALS	UL62368-1, ANSI/AAMI ES60601-1, C-UL, EN62368-1, EN60601-1 3rd, Complies with IEC60601-1-2 4th Ed.				
	CONDUCTED NOISE	Complies with FCC Part15 classB, VCCI-B, CISPR32-B, EN55011-B, EN55032-B				
OTHERS	HARMONIC ATTENUATOR *5	Complies with IEC61000-3-2 (class A)				
	CASE SIZE/WEIGHT	50.8×37×101.6mm [2.0×1.5×4.0 inches] (W×H×D) / 230g max				
	COOLING METHOD	Forced air (Requires external fan)				

*1 This is the value that measured on measuring board with capacitor of 22μF at 150mm from output terminal.
 Measured by 20MHz oscilloscope or Ripple-Noise meter (Equivalent to KEISOKU-GIKEN: RM103).
 *2 Drift is the change in DC output for an eight hour period after a half-hour warm-up at 25°C, with the input voltage held constant at the rated input/output.
 *3 Refer to "Derating"
 *4 Please contact us about dynamic load and input response.
 *5 Please contact us about another class.

*6 Specification is changed at option, refer to Instruction Manual.
 *7 Applicable when AUX and remote control (optional) is added.
 *8 Please contact us about for more detail.
 * To meet the specifications. Do not operate over-loaded condition.
 * Parallel operation is not possible.
 * Sound noise may be generated by power supply in case of pulse load.
 * Substrate bottom has a Electric potential. Insulation is required.

Features

- High power density : 25.7W/inch³
- High efficiency : 93% typ (Input Voltage 230V, Output Voltage 24V)
- For medical electric equipment (ANSI/AAMI ES60601-1, EN60601-1 3rd, IEC60601-1-2 4th Ed.)
- Suitable for BF application (Output-FG : 1MOPP, Input-Output : 2MOPP)
- 2" × 4" standard footprint
- With Remote ON/OFF (Optional)
- With AUX1 (12V 1A), AUX2 (5V 1A) (Optional)

Block diagram

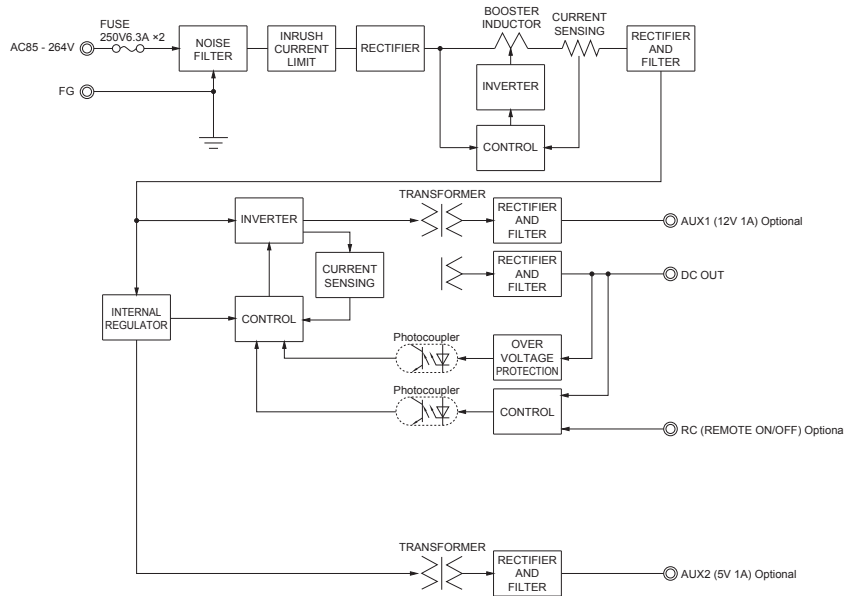

External view

* External size of option J3 is different from standard model and refer to 6 Option and Others of instruction manual for details.

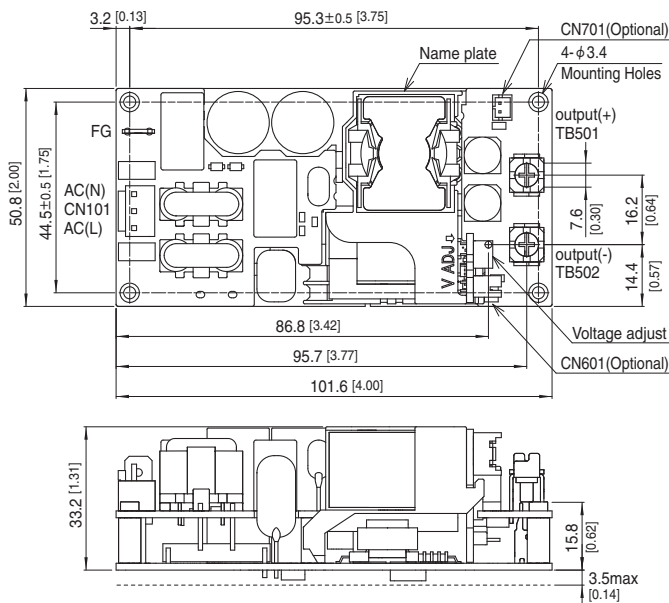

- * Tolerance ±1 [±0.04]
- * Weight : 230g max
- * There is a total of four attachment holes.
- * Dimensions in mm, []=inches
- * Screw tightening torque : (TB501, 502) : 1.25N · m max
- * Mounting torque : 0.6N · m max
- * Avoid contact between TB501 and 502 wiring with mounting parts.

	I/O Connector	Mating connector	Terminal	Mfr
Standard	CN101	1-1123724-2	1123721-1	Tyco Electronics
	CN101	1-1123722-3	1318912-1	
R3	CN601	B8B-PHDSS	PHDR-08VS	J.S.T.
	CN701	B2B-PH	PHR-2	
J1	CN101	B2P3-VH	VHR-3N	J.S.T.
J1R3	CN601	B8B-PHDSS	PHDR-08VS	
	CN701	B2B-PH	PHR-2	SPH-002T-P0.5S

FG	Mating connector	Terminal	Mfr
250 (62409-1)	-	170603-2	Tyco Electronics

<Pin Assignments>

<CN101>

Pin No.	Input
1	AC(L)
2	
3	AC(N)

<CN601(Optional)>

Pin No.	Function
1	RC : REMOTE ON/OFF
2	RCG : REMOTE ON/OFF(GND)
3	N.C. : No connection
4	N.C. : No connection
5	N.C. : No connection
6	N.C. : No connection
7	AUX2 : AUX2 (5V 1A)
8	AUX2G : AUX2 (GND)

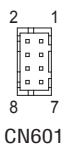

CN601

<CN701(Optional)>

Pin No.	Function
1	AUX1G : AUX1 (GND)
2	AUX1 : AUX1 (12V 1A)



CN701

Assembling and Installation Method

■ Mounting method

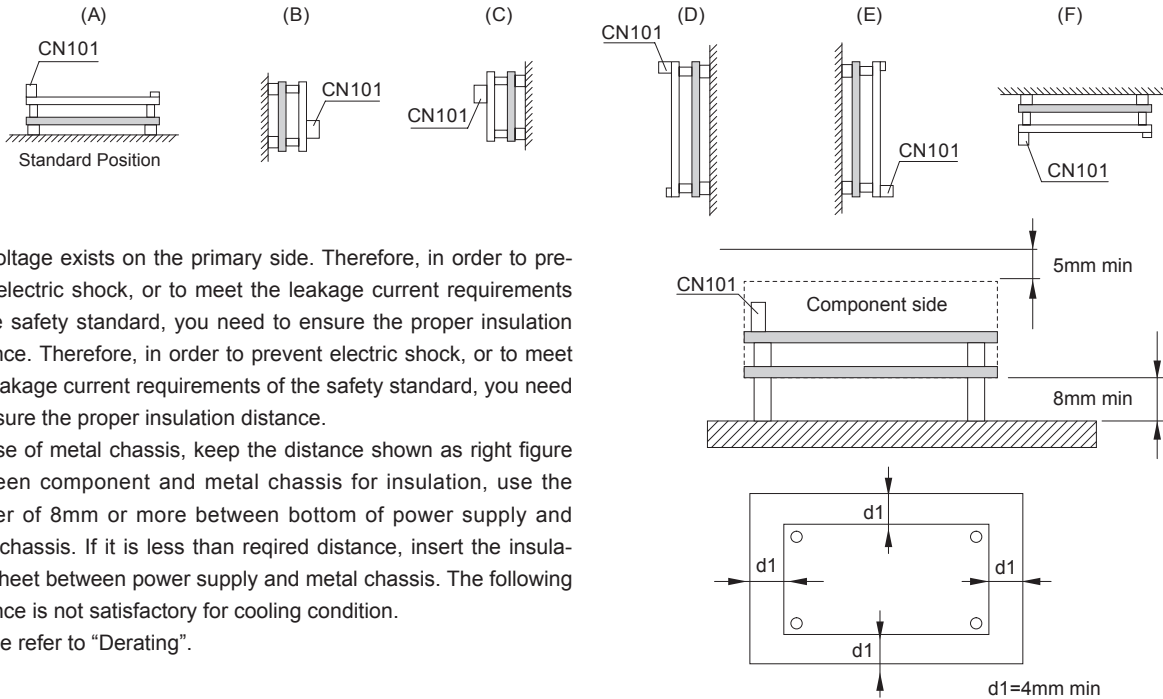

■ AC voltage exists on the primary side. Therefore, in order to prevent electric shock, or to meet the leakage current requirements of the safety standard, you need to ensure the proper insulation distance. Therefore, in order to prevent electric shock, or to meet the leakage current requirements of the safety standard, you need to ensure the proper insulation distance.

■ In case of metal chassis, keep the distance shown as right figure between component and metal chassis for insulation, use the spacer of 8mm or more between bottom of power supply and metal chassis. If it is less than required distance, insert the insulation sheet between power supply and metal chassis. The following distance is not satisfactory for cooling condition. Please refer to "Derating".

Mounting screw

- The mounting screw should be M3. The hatched area shows the allowance of metal parts for mounting.
- If metallic fittings are used on the component side of the board, ensure there is no contact with surface mounted components.
- This product uses SMD technology. Please avoid the PCB installation method which includes the twisting stress or the bending stress.

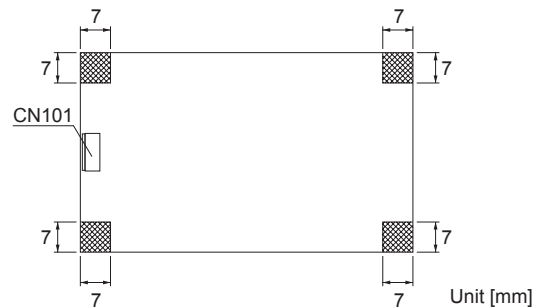

Derating

■ Cooling method

Conduction cooling are available. Please see instruction manual 3 for details. Please make sure the maximum component temperature rise given in instruction manual 3 is not exceeded.

● Derating curve for input voltage

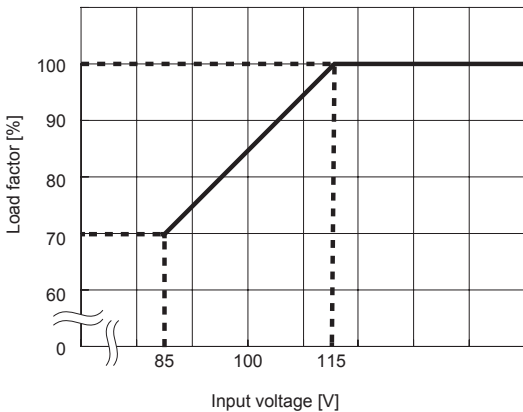

Derating

Ambient temperature derating curve at forced air (Reference value)

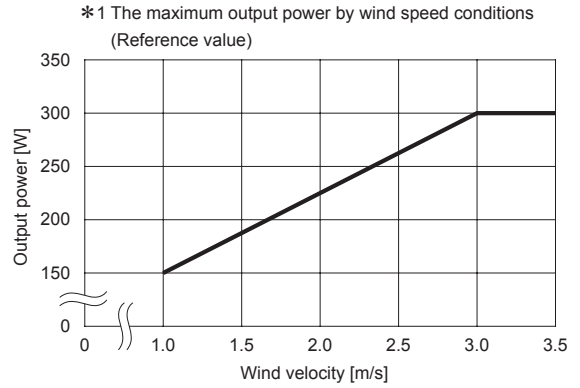
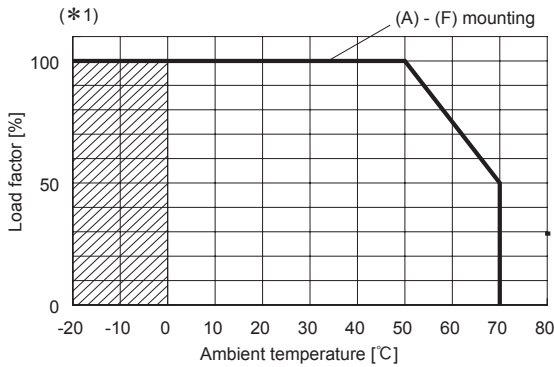

- Specifications for ripple and ripple noise changes in the shaded area.
- Please see instruction manual 3 for recommended cooling condition.

Instruction Manual

It is necessary to read the "Instruction Manual" and "Before using our product" before you use our product.

Instruction Manual <https://www.cosel.co.jp/redirect/catalog/en/GMA/>
 Before using our product <https://en.cosel.co.jp/technical/caution/index.html>

GMA



NOTICE



Basic Characteristics Data

Model	Circuit method	Switching frequency [kHz]	Input current *1 [A]	Inrush current protection	PCB/Pattern			Series/Parallel operation availability	
					Material	Single sided	Double sided	Series operation	Parallel operation
GMA300F	Active filter	40 - 120	3.3	Thermistor	FR-4	-	Yes	Yes	No
	LLC resonant converters	90 - 180							

*1 The value of input current is at ACIN 115V and rated load.



GHA-series

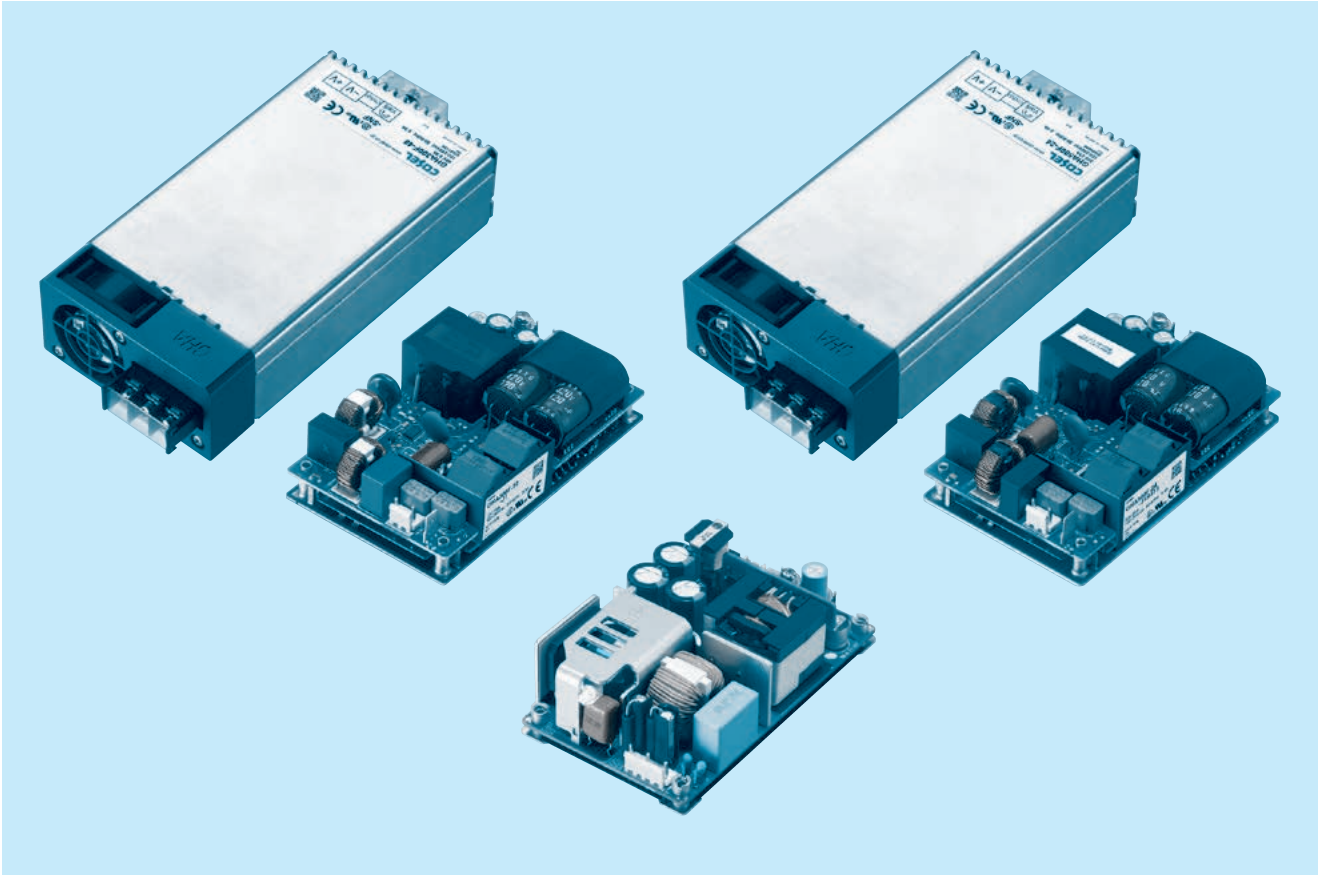

Feature

- Wattage 700Wmax
- Conduction cooling (GHA500F, GHA700F)
- 3" X 5" standard footprint
- Less than 1U high
- ITE and Medical safety approvals
- Low leakage current
- Suitable for BF application
(Output-FG : 1MOFF, Input-Output :2MOFF) (GHA700F)
- With Remote (Option)
- With AUX1 (12V), AUX2(5V) (Option)
- With FAN (GHA300F-SNF, GHA500F-SNF)

Safety agency approvals

- UL60950-1 (GHA300F, 500F), UL62368-1 (GHA700F)
- ANSI/AAMI ES60601-1, C-UL
- EN62368-1, EN60601-1 3rd
- Complies with IEC60601-1-2 4th
- DEN-AN (GHA300F, 500F)
- EN61558-2-16 (GHA700F)

5-year warranty (Refer to Instruction Manual)

CE marking

- Low Voltage Directive
- RoHS Directive

UKCA marking

- Electrical Equipment Safety Regulations
- RoHS Regulations

EMI

- Complies with FCC-B, CISPR11-B, CISPR32-B, EN55011-B
- EN55032-B, VCCI-B

EMS Compliance : EN61204-3, EN61000-6-2 IEC60601-1-2 (2014), EN60601-1-2 (2015)

- EN61000-4-2
- EN61000-4-3
- EN61000-4-4
- EN61000-4-5
- EN61000-4-6
- EN61000-4-8
- EN61000-4-11

GHA300F

GH A 300 F -□□ -□

① ② ③ ④ ⑤ ⑥

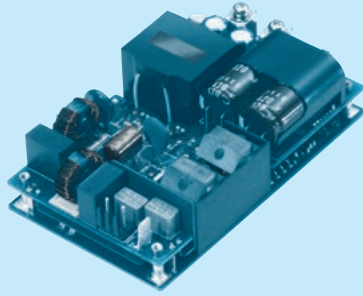

Example recommended EMI/EMC filter EAC-10-472



High voltage pulse noise type : EAP series
Low leakage current type : EAM series
* A higher current rating EMI/EMC filter may be recommended in view of the other devices that could be connected in parallel with the power supply.

- ① Series name
 - ② Single output
 - ③ Output wattage
 - ④ Universal input
 - ⑤ Output voltage
 - ⑥ Optional *6
- T3 : mounting hole M3
J1 : J.S.T.connector type
J3 : Horizontal input connector
J.S.T.connector type
R3 : with Subfeatures (5VAUX,12VAUX,Remote, Power good)(Molex connector type)
*with friction locks,J2R3

Specification is changed at option, refer to Instruction manual.

This power supply is manufactured by SMD technology. The stress to P.C.B like twisting or bending causes the defect of the unit, please handle the unit with care
*Make sure necessary tests will be carried out on your end equipment with the power supply installed in accordance with any required EMC/EMI regulations.

MODEL	GHA300F-12		GHA300F-24		GHA300F-48	
MAX OUTPUT WATTAGE[W]	300		300		302.4	
DC OUTPUT	Forced air	at 50°C	12V 25A	24V 12.5A	48V 6.3A	
		at 40°C	12V 8.4A	24V 4.2A	48V 2.1A	
	Convection	at 50°C	12V 4.5A	24V 2.2A	48V 1.1A	

SPECIFICATIONS

	MODEL	GHA300F-12		GHA300F-24		GHA300F-48		
INPUT	VOLTAGE[V]	AC90 - 264 1 φ (output derating is required at AC90V -115V *3)						
	CURRENT[A]	ACIN 120V	3.3typ					
		ACIN 230V	1.8typ					
	FREQUENCY[Hz]	50 / 60 (47 - 63)						
	EFFICIENCY[%]	ACIN 120V	89typ		90typ		90typ	
		ACIN 230V	91typ		92typ		92typ	
	POWER FACTOR (Io=100%)	ACIN 120V	0.95typ					
		ACIN 230V	0.90typ					
INRUSH CURRENT[A]	ACIN 120V	20typ (Io=100%) (At cold start) (Ta=25°C)						
	ACIN 230V	40typ (Io=100%) (At cold start) (Ta=25°C)						
LEAKAGE CURRENT[ma]	0.125/0.250max (ACIN 120V/240V 60Hz,Io=100%, According to IEC60601-1)							
OUTPUT	VOLTAGE[V]	12		24		48		
	CURRENT[A]	Forced air	25.0		12.5		6.3	
		Convection	4.5		2.2		1.1	
	LINE REGULATION[mV]	*4 48max		96max		192max		
	LOAD REGULATION[mV]	*4 100max		150max		240max		
	RIPPLE[mVp-p]	*1 0 to +50°C	240max		240max		300max	
		-20 to 0°C	320max		320max		400max	
	RIPPLE NOISE[mVp-p]*1	0 to +50°C	300max		300max		480max	
		-20 to 0°C	360max		360max		500max	
	TEMPERATURE REGULATION[mV]	0 to +50°C	120max		240max		480max	
		-20 to +50°C	150max		290max		600max	
	DRIFT[mV]	*2 48max		96max		192max		
	START-UP TIME[ms]	500typ (ACIN 120V, Io=100%)						
	HOLD-UP TIME[ms]	16typ (ACIN 120V, Io=100%)						
OUTPUT VOLTAGE ADJUSTMENT RANGE[V]	10.80 to 13.20		21.60 to 26.40		43.20 to 52.80			
OUTPUT VOLTAGE SETTING[V]	12.00 to 12.48		24.00 to 24.96		48.00 to 49.92			
PROTECTION CIRCUIT AND OTHERS	OVERCURRENT PROTECTION	Works over 105% of rating and recovers automatically						
	OVERVOLTAGE PROTECTION[V]	13.80 to 16.80		27.60 to 33.60		55.20 to 67.20		
	AUX1 (12V1A)	Optional						
	AUX2 (5V1A)	Optional						
	REMOTE ON/OFF	Optional						
	PowerGood	Optional						
ISOLATION	INPUT-OUTPUT · RC · AUX *7	AC4,000V 1minute, Cutoff current = 10mA, DC500V 50MΩ min (At Room Temperature) 2MOPP						
	INPUT-FG	AC2,000V 1minute, Cutoff current = 10mA, DC500V 50MΩ min (At Room Temperature) 1MOPP						
	OUTPUT · RC · AUX-FG *7	AC500V 1minute, Cutoff current = 25mA, DC500V 50MΩ min (At Room Temperature)						
	OUTPUT-RC · AUX *7	AC500V 1minute, Cutoff current = 25mA, DC500V 50MΩ min (At Room Temperature)						
ENVIRONMENT	OPERATING TEMP., HUMID. AND ALTITUDE	-20 to +70°C, 20 - 90%RH (Non condensing), 3,000m (10,000feet) max *3						
	STORAGE TEMP., HUMID. AND ALTITUDE	-30 to +75°C, 20 - 90%RH (Non condensing), 9,000m (30,000feet) max						
	VIBRATION	10 - 55Hz, 19.6m/s ² (2G), 3minutes period, 60minutes each along X, Y and Z axis						
	IMPACT	196.1m/s ² (20G), 11ms, once each X, Y and Z axis						
SAFETY AND NOISE REGULATIONS	AGENCY APPROVALS	UL60950-1, ANSI/AAMI ES60601-1, C-UL(CSA60950-1, CAN/CSA60601-1), EN62368-1, EN60601-1 3rd, Complies with DEN-AN, IEC60601-1-2 4th Ed.						
	CONDUCTED NOISE	Complies with FCC-B, VCCI-B, CISPR11-B, CISPR22-B, EN55011-B, EN55022-B						
	HARMONIC ATTENUATOR	Complies with IEC61000-3-2 (class A) *5						
OTHERS	CASE SIZE/WEIGHT	76.2 X 35 X 127mm [3.0 X 1.4 X 5.0 inches] (W X H X D) / 400g max						
	COOLING METHOD	Convection, Forced air (Require external fan)						

*1 This is the value that measured on measuring board with capacitor of 22 μF at 150mm from output terminal.
Measured by 20MHz oscilloscope or Ripple-Noise meter (Equivalent to KEISOKU-GIKEN: RM103).
*2 Drift is the change in DC output for an eight hour period after a half-hour warm-up at 25°C, with the input voltage held constant at the rated input/output.
*3 Derating is required.
*4 Please contact us about dynamic load and input response.
*5 Please contact us about another class.

*6 Specification is changed at option, refer to Instruction Manual
*7 Applicable when AUX and remote control (optional) is added.
* To meet the specifications. Do not operate over-loaded condition.
* Sound noise may be generated by power supply in case of pulse load.
* Parallel operation is not possible.
* Forced air cooling is required to output up to MAX OUTPUT WATTAGE.
* Bottom layer P.C.B has electric potential which is required isolation from FG by clearance or creepage as the safety design issue.

Features

- High Power density: 14.3W/inch³
- 3" × 5" standard footprint
- Industrial and Medical safety approvals
- With Remote On/Off (Optional)
- No minimum load is required
- High efficiency 92% typ (Input Voltage 230V, Output Voltage 24V)
- Fits 1U applications
- Low leakage current
- With AUX1 (12V), AUX2 (5V) (Optional)

Block diagram

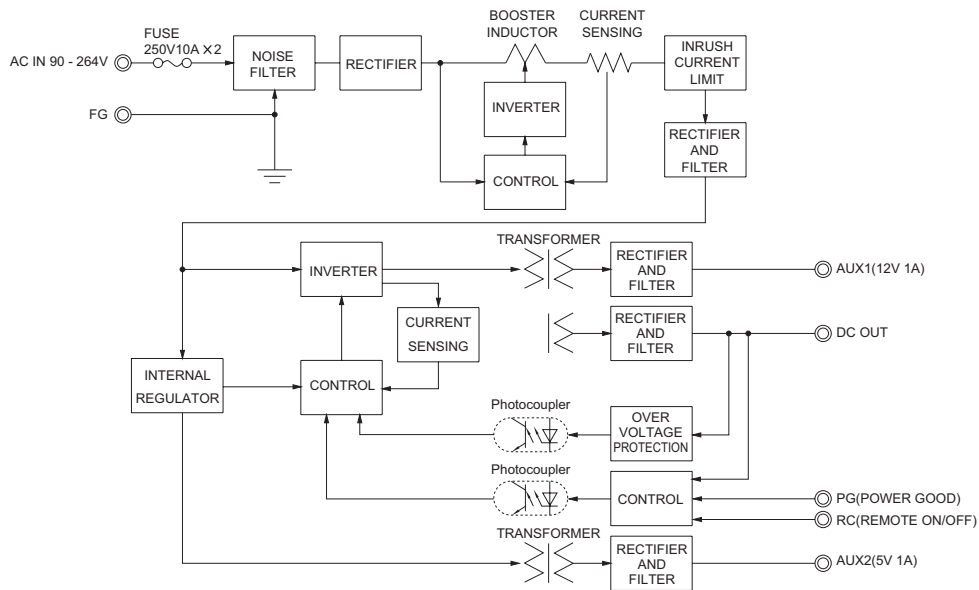

External view

*External size of option J3 is different from standard model and refer to 6 Option and Others of instruction manual for details.

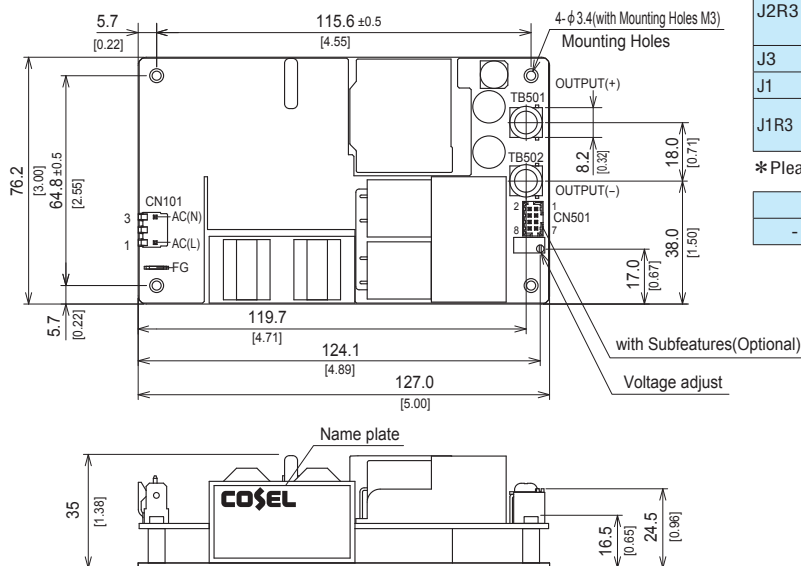

- ※ Tolerance ±1 [±0.04]
- ※ Weight : 400g max
- ※ There is a total of four attachment holes.
- ※ This power supply requires mounting on metal standoffs 5mm in height. (Insulating sheet is required if you do not use a spacer).
- ※ Dimensions in mm, []=inches
- ※ Screw tightening torque : (TB501, 502) : 1.5N · m max
- ※ Mounting torque : 0.6N · m max
- ※ Avoid contact between TB501 and 502 wiring with mounting parts.
- ※ Option : -J1 : (J.S.T) connector type. Refer to Instruction Manual 6.

		Connector	Mating connector	Terminal	Mfr
Standard	CN101	A-41671-A03A197-2	09-50-8031	08-50-0105 08-65-0114	Molex *
	CN501	087831-0820	51110-0851	50394-8051	
	CN501	087831-0841	51110-0860	50394-8051	
J2R3	CN101	A-41671-A03A197-2	09-50-8031	08-50-0105 08-65-0114	J.S.T.
J3	CN101	S2P3-VH			
J1	CN101	B2P3-VH	VHR-3N	SVH-21T-P1.1	J.S.T.
J1R3	CN501	B8B-PHDSS	PHDR-08VS	SPHD-002T-P0.5	

*Please note the pin position No.1 is different from Molex.

	FG	Mating connector	Terminal	Mfr
-	250 Series	-	170603-2	Tyco Electronics

<Pin Assignments>

<CN101>

Pin No.	Input
1	AC(L)
2	
3	AC(N)

<CN501(Optional)>

Pin No.	Function
1	AUX1 : AUX1 (12V1A)
2	AUX1G: AUX1 (GND)
3	RC : REMOTE ON/OFF
4	RCG : REMOTE ON/OFF (GND)
5	PG : Power good
6	PGG : Power good (GND)
7	AUX2 : AUX2 (5V1A)
8	AUX2G: AUX2 (GND)

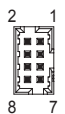

CN501

GHA500F

GH A 500 F -□□ -□
 ① ② ③ ④ ⑤ ⑥

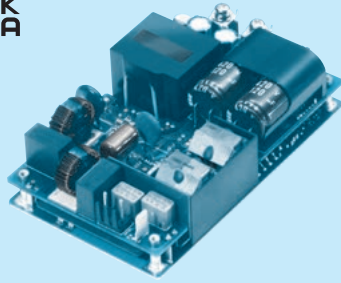

Example recommended EMI/EMC filter
EAC-10-472



High voltage pulse noise type : EAP series
 Low leakage current type : EAM series
 * A higher current rating EMI/EMC filter may be recommended in view of the other devices that could be connected in parallel with the power supply.

- ① Series name
- ② Single output
- ③ Output wattage
- ④ Universal input
- ⑤ Output voltage
- ⑥ Optional *6
- T3 : mounting hole M3
- J1 : J.S.T.connector type
- J3 : Horizontal input connector J.S.T.connector type
- R3 : with Subfeatures (5VAUX, 12VAUX, Remote, Power good)(Molex connector type)
- *with friction locks, J2R3
- P : Parallel Operation

This power supply is manufactured by SMD technology. The stress to P.C.B like twisting or bending causes the defect of the unit, please handle the unit with care
 *Make sure necessary tests will be carried out on your end equipment with the power supply installed in accordance with any required EMC/EMI regulations.

Specification is changed at option, refer to Instruction manual.

MODEL	GHA500F-12	GHA500F-15	GHA500F-24	GHA500F-30	GHA500F-48	GHA500F-56		
MAX OUTPUT WATTAGE[W]	500.4	501	504	501	504	504		
DC OUTPUT	Forced air	at 50°C	12V 41.7A	15V 33.4A	24V 21.0A	30V 16.7A	48V 10.5A	56V 9.0A
		at 40°C	12V 12.5A	15V 10.0A	24V 6.3A	30V 5.0A	48V 3.2A	56V 2.7A
	Convection	at 50°C	12V 9.2A	15V 7.4A	24V 4.6A	30V 3.7A	48V 2.3A	56V 1.9A
		at 0°C	12V 30.0A	15V 24.0A	24V 15.0A	30V 12.0A	48V 7.5A	56V 6.4A
conduction cooling	at 50°C	12V 16.7A	15V 13.4A	24V 8.4A	30V 6.7A	48V 4.2A	56V 3.6A	

SPECIFICATIONS

MODEL	GHA500F-12	GHA500F-15	GHA500F-24	GHA500F-30	GHA500F-48	GHA500F-56			
INPUT	VOLTAGE[V]	AC90 - 264 1 φ (output derating is required at AC90V -115V *3)							
	CURRENT[A]	ACIN 120V	5.4typ						
		ACIN 230V	2.9typ						
	FREQUENCY[Hz]	50 / 60 (47 - 63)							
	EFFICIENCY[%]	ACIN 120V	88typ	90typ	90typ	90typ	90typ		
		ACIN 230V	90typ	92typ	92typ	92typ	92typ		
	POWER FACTOR (lo=100%)	ACIN 120V	0.95typ						
		ACIN 230V	0.90typ						
	INRUSH CURRENT[A]	ACIN 120V	20typ (lo=100%) (At cold start) (Ta=25°C)						
		ACIN 230V	40typ (lo=100%) (At cold start) (Ta=25°C)						
LEAKAGE CURRENT[mA]	0.125/0.250max (ACIN 120V/240V 60Hz, lo=100%, According to IEC60601-1)								
OUTPUT	VOLTAGE[V]	12	15	24	30	48	56		
	CURRENT[A]	Forced air	41.7	33.4	21.0	16.7	10.5	9.0	
		Convection	9.2	7.4	4.6	3.7	2.3	1.9	
		conduction cooling	16.7	13.4	8.4	6.7	4.2	3.6	
	LINE REGULATION[mV]	*4	48max	60max	96max	120max	192max	192max	
	LOAD REGULATION[mV]	*4	100max	120max	150max	180max	240max	240max	
	RIPPLE[mVp-p]	*1	0 to +50°C	240max	240max	240max	300max	300max	400max
		-20 - 0°C	320max	320max	320max	400max	400max	500max	
	RIPPLE NOISE[mVp-p]*1	0 to +50°C	300max	300max	300max	480max	480max	500max	
		-20 - 0°C	360max	360max	360max	500max	500max	580max	
TEMPERATURE REGULATION[mV]	0 to +50°C	120max	150max	240max	300max	480max	480max		
	-20 to +50°C	150max	180max	290max	360max	600max	600max		
DRIFT[mV]	*2	48max	60max	96max	120max	192max	192max		
START-UP TIME[ms]	500typ (ACIN 120V, lo=100%)								
HOLD-UP TIME[ms]	16typ (ACIN 120V, lo=100%)								
OUTPUT VOLTAGE ADJUSTMENT RANGE[V]	10.80 to 13.20 13.50 to 16.50 21.60 to 26.40 27.00 to 31.50 43.20 to 52.80 52.00 to 56.00								
OUTPUT VOLTAGE SETTING[V]	12.00 to 12.48 15.00 to 15.30 24.00 to 24.96 30.00 to 31.20 48.00 to 49.92 55.00 to 56.00								
PROTECTION CIRCUIT AND OTHERS	OVERCURRENT PROTECTION	Works over 105% of rating and recovers automatically							
	OVERVOLTAGE PROTECTION[V]	13.80 to 16.80 17.25 to 21.00 27.60 to 33.60 34.50 to 42.00 55.20 to 67.20 60.00 to 69.00							
	AUX1 (12V1A)	Optional							
	AUX2 (5V1A)	Optional							
	REMOTE ON/OFF	Optional							
PowerGood	Optional								
ISOLATION	INPUT-OUTPUT · RC · AUX	*7 AC4,000V 1minute, Cutoff current = 10mA, DC500V 50MΩ min (At Room Temperature) 2MOPP							
	INPUT-FG	AC2,000V 1minute, Cutoff current = 10mA, DC500V 50MΩ min (At Room Temperature) 1MOPP							
	OUTPUT · RC · AUX-FG	*7 AC500V 1minute, Cutoff current = 25mA, DC500V 50MΩ min (At Room Temperature)							
	OUTPUT-RC · AUX	*7 AC500V 1minute, Cutoff current = 25mA, DC500V 50MΩ min (At Room Temperature)							
ENVIRONMENT	OPERATING TEMP., HUMID. AND ALTITUDE	-20 to +80°C, 20 - 90%RH (Non condensing), 3,000m (10,000feet) max							
	STORAGE TEMP., HUMID. AND ALTITUDE	-30 to +80°C, 20 - 90%RH (Non condensing), 9,000m (30,000feet) max							
	VIBRATION	10 - 55Hz, 19.6m/s ² (2G), 3minutes period, 60minutes each along X, Y and Z axis							
	IMPACT	196.1m/s ² (20G), 11ms, once each X, Y and Z axis							
SAFETY AND NOISE REGULATIONS	AGENCY APPROVALS	UL60950-1, ANSI/AAMI ES60601-1, C-UL(CSA60950-1, CAN/CSA60601-1), EN62368-1, EN60601-1 3rd, Complies with DEN-AN, IEC60601-1-2 4th Ed.							
	CONDUCTED NOISE	Complies with FCC-B, VCCI-B, CISPR11-B, CISPR22-B, EN55011-B, EN55022-B							
	HARMONIC ATTENUATOR	Complies with IEC61000-3-2 (class A) *5							
OTHERS	CASE SIZE/WEIGHT	76.2 X 35 X 127mm [3.0 X 1.4 X 5.0 inches] / 420g max							
	COOLING METHOD	Convection, Forced air (Require external fan), Conduction cooling							

*1 This is the value that measured on measuring board with capacitor of 22 μF at 150mm from output terminal.
 Measured by 20MHz oscilloscope or Ripple-Noise meter (Equivalent to KEISOKU-GIKEN: RM103).
 *2 Drift is the change in DC output for an eight hour period after a half-hour warm-up at 25°C, with the input voltage held constant at the rated input/output.
 *3 Derating is required.
 *4 Please contact us about dynamic load and input response.

*5 Please contact us about another class.
 *6 Specification is changed at option, refer to Instruction Manual.
 *7 Applicable when AUX and remote control (optional) is added.
 * To meet the specifications. Do not operate over-loaded condition.
 * Sound noise may be generated by power supply in case of pulse load.
 * Parallel operation is available with -P option. Refer to 5.1 on the instruction manual.
 * Forced air cooling is required to output up to MAX OUTPUT WATTAGE.

Features

- **Wattage 500W max**
- **High efficiency 92% typ (Input Voltage 230V, Output Voltage 24V)**
- **Conduction cooling**
- **Fits 1U applications**
- **Low leakage current**
- **With AUX1 (12V), AUX2 (5V) (Optional)**
- **High Power density: 24.1W/inch³**
- **3" × 5" standard footprint**
- **Industrial and Medical safety approvals**
- **With Remote On/Off (Optional)**
- **No minimum load is required**

Block diagram

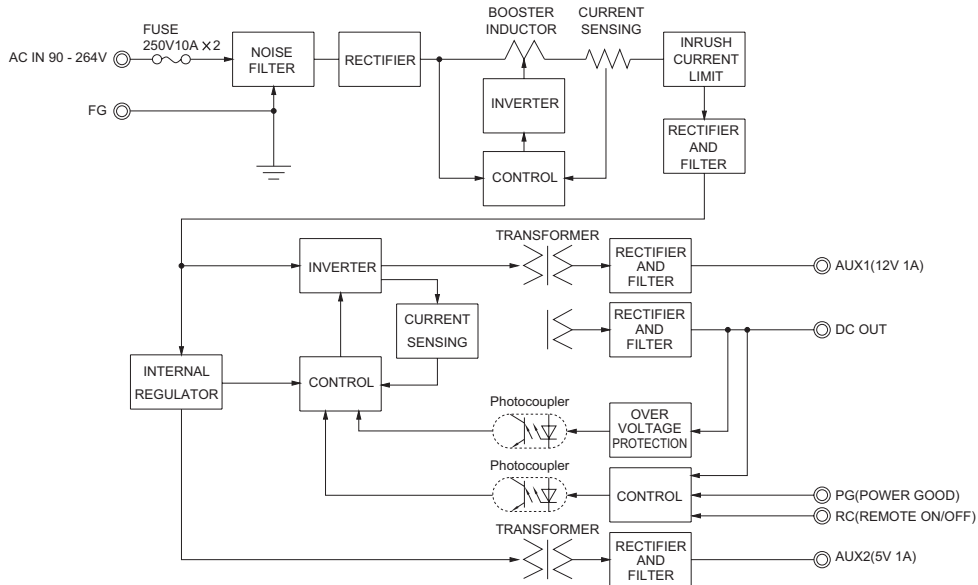

External view

* External size of option J3 is different from standard model and refer to 6 Option and Others of instruction manual for details.

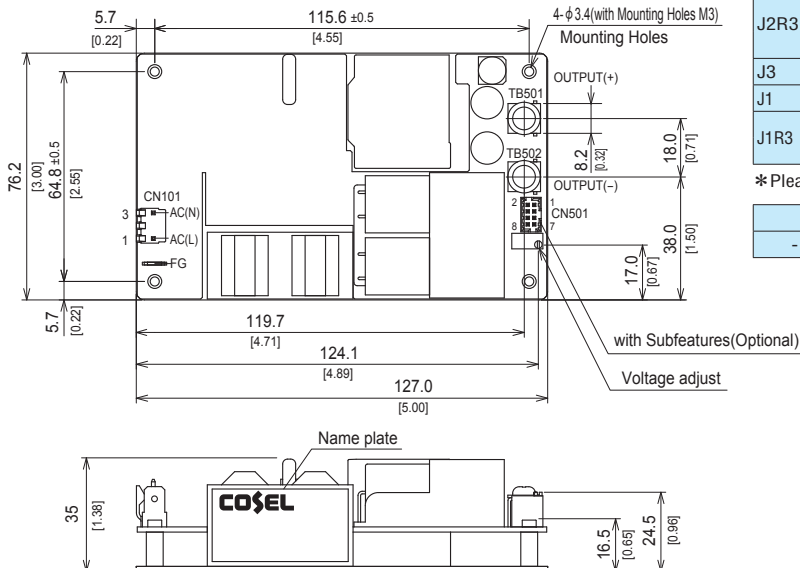

- ※ Tolerance ±1 [±0.04]
- ※ Weight : 420g max
- ※ There is a total of four attachment holes.
- ※ Base Plate : Aluminum
- ※ Dimensions in mm, []=inches
- ※ Screw tightening torque : (TB501, 502) : 1.5N · m max
- ※ Mounting torque : 0.6N · m max
- ※ Avoid contact between TB501 and 502 wiring with mounting parts.
- ※ Option : J1 : (J.S.T) connector type. Refer to Instruction Manual 6.

Connector		Mating connector	Terminal	Mfr	
Standard	CN101	A-41671-A03A197-2	09-50-8031	08-50-0105 08-65-0114	Molex *
	CN501	087831-0820	51110-0851	50394-8051	
J2R3	CN101	A-41671-A03A197-2	09-50-8031	08-50-0105 08-65-0114	
	CN501	087831-0841	51110-0860	50394-8051	
J3	CN101	S2P3-VH	VHR-3N	SVH-21T-P1.1	J.S.T.
J1	CN101	B2P3-VH			
J1R3	CN501	B8B-PHDSS	PHDR-08VS	SPHD-002T-P0.5	

* Please note the pin position No.1 is different from Molex.

FG	Mating connector	Terminal	Mfr
-	250 Series	-	170603-2 Tyco Electronics

<Pin Assignments>

<CN101>

Pin No.	Input
1	AC(L)
2	
3	AC(N)

<CN501 (Optional)>

Pin No.	Function
1	AUX1 : AUX1 (12V1A)
2	AUX1G: AUX1 (GND)
3	RC : REMOTE ON/OFF
4	RCG : REMOTE ON/OFF (GND)
5	PG : Power good
6	PGG : Power good (GND)
7	AUX2 : AUX2 (5V1A)
8	AUX2G: AUX2 (GND)



CN501

GHA700F

GH A 700 F -□□ -□
 ① ② ③ ④ ⑤ ⑥

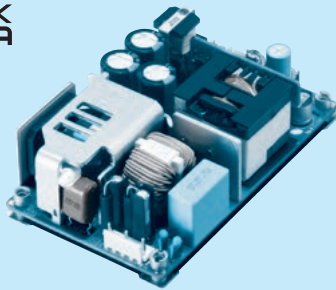

Example recommended EMI/EMC filter
EAC-16-472



High voltage pulse noise type : EAP series
 Low leakage current type : EAM series
 * A higher current rating EMI/EMC filter may be recommended in view of the other devices that could be connected in parallel with the power supply.

■ BF

- ① Series name
- ② Single output
- ③ Output wattage
- ④ Universal input
- ⑤ Output voltage
- ⑥ Optional *1
- C : with Coating
- E : IEC Class II
- R3 : with Subfeatures (5VAUX, 12VAUX, Remote, Power good)
- T3 : mounting hole M3
- U1 : can attach an external capacitor unit

Specification is changed at option, refer to instruction manual.

This power supply is manufactured by SMD technology. The stress to P.C.B like twisting or bending causes the defect of the unit, please handle the unit with care
 *Make sure necessary tests will be carried out on your end equipment with the power supply installed in accordance with any required EMC/EMI regulations.

MODEL	GHA700F-24-J1	GHA700F-30-J1	GHA700F-48-J1	GHA700F-56-J1	
MAX OUTPUT WATTAGE[W]	700.8	699.0	700.8	700.0	
DC OUTPUT	Forced air at 50°C Convection at 30°C at 50°C conduction cooling at 50°C	24V 29.2A	30V 23.3A	48V 14.6A	56V 12.5A
		24V 16.7A	30V 13.4A	48V 8.4A	56V 7.2A
		24V 11.1A	30V 8.9A	48V 5.6A	56V 4.8A
		24V 16.7A	30V 13.4A	48V 8.4A	56V 7.2A

SPECIFICATIONS

	MODEL	GHA700F-24-J1	GHA700F-30-J1	GHA700F-48-J1	GHA700F-56-J1	
INPUT	VOLTAGE[VAC]	85 - 264 1φ (Refer to "Derating" and Instruction Manual 1.1)				
	CURRENT[A]	ACIN 115V	7.0typ			
		ACIN 230V	3.5typ			
	FREQUENCY[Hz]	50 / 60 (45 - 66)				
	EFFICIENCY[%]	ACIN 115V	94.0typ (Po=400W)	94.0typ (Po=400W)	94.0typ (Po=400W)	94.0typ (Po=400W)
			93.0typ (Po=700W)	93.0typ (Po=700W)	93.0typ (Po=700W)	93.0typ (Po=700W)
		ACIN 230V	96.0typ (Po=400W)	96.0typ (Po=400W)	96.0typ (Po=400W)	96.0typ (Po=400W)
			95.5typ (Po=700W)	95.5typ (Po=700W)	95.5typ (Po=700W)	95.5typ (Po=700W)
	POWER FACTOR (Po=700W)	ACIN 115V	0.95typ			
		ACIN 230V	0.90typ			
INRUSH CURRENT[A]	ACIN 115V	20typ (Po=700W) (At cold start) (Ta=25°C)				
	ACIN 230V	40typ (Po=700W) (At cold start) (Ta=25°C)				
EARTH LEAKAGE CURRENT[μA]	100/200max (ACIN 100/264V 60Hz, Po=700W, According to IEC60601-1)					
TOUCH CURRENT[μA]	100max (ACIN 264V 60Hz, Po=700W, According to IEC60601-1)					
OUTPUT	VOLTAGE[VAC]	24	30	48	56	
	CURRENT[A]	Forced air	29.2	23.3	14.6	12.5
		Convection	16.7	13.4	8.4	7.2
		conduction cooling	16.7	13.4	8.4	7.2
	LINE REGULATION[mV]	96max	120max	192max	192max	
	LOAD REGULATION[mV]	150max	180max	240max	240max	
	RIPPLE[mVp-p]	0 to +50°C	300max	350max	550max	600max
		-20°C to +0°C	400max	500max	700max	750max
	RIPPLE NOISE[mVp-p]	0 to +50°C	400max	450max	650max	700max
		-20°C to +0°C	500max	600max	800max	850max
	TEMPERATURE REGULATION[mV]	0 to +50°C	240max	300max	480max	600max
		-20°C to +50°C	290max	360max	600max	720max
	DRIFT[mV]	96max	120max	192max	192max	
	START-UP TIME[ms]	500typ (ACIN 115V, Po=700W)				
	HOLD-UP TIME[ms]	12typ (ACIN 115V, Po=700W)				
OUTPUT VOLTAGE ADJUSTMENT RANGE[V]	22.80 to 26.40	28.50 to 33.00	45.60 to 52.80	53.20 to 61.60		
OUTPUT VOLTAGE SETTING[V]	24.00 to 24.96	30.00 to 31.20	48.00 to 49.92	56.00 to 58.24		
PROTECTION CIRCUIT AND OTHERS	OVERCURRENT PROTECTION	Works over 105% of rating and recovers automatically				
	OVERVOLTAGE PROTECTION[V]	27.60 to 33.60	34.50 to 42.00	55.20 to 67.20	64.40 to 78.40	
	AUX1 (12V1A)	Optional (Refer to Instruction Manual 6.1)				
	AUX2 (5V1A)	Optional (Refer to Instruction Manual 6.1)				
	REMOTE ON/OFF	Optional (Refer to Instruction Manual 6.1)				
POWER GOOD	Optional (Refer to Instruction Manual 6.1)					
ISOLATION	INPUT-OUTPUT · RC · AUX	AC4,000V 1minute, Cutoff current = 10mA, DC500V 50MΩ min (At Room Temperature) 2MOPP				
	INPUT-FG	AC2,000V 1minute, Cutoff current = 10mA, DC500V 50MΩ min (At Room Temperature) 1MOPP				
	OUTPUT · RC · AUX-FG	AC1,500V 1minute, Cutoff current = 10mA, DC500V 50MΩ min (At Room Temperature) 1MOPP				
	OUTPUT-RC · AUX	AC500V 1minute, Cutoff current=25mA, DC500V 50MΩ min (At Room Temperature)				
ENVIRONMENT	OPERATING TEMP., HUMID. AND ALTITUDE	-20 to +80°C, 20 - 90%RH (Non condensing), 3,000m (10,000feet) max				
	STORAGE TEMP., HUMID. AND ALTITUDE	-30 to +80°C, 20 - 90%RH (Non condensing), 9,000m (30,000feet) max				
	VIBRATION	10 - 55Hz, 19.6m/s ² (2G), 3minutes period, 60minutes each along X, Y and Z axis				
	IMPACT	196.1m/s ² (20G), 11ms, once each X, Y and Z axis				
SAFETY AND NOISE REGULATIONS	AGENCY APPROVALS	UL62368-1, ANSI/AAMI ES60601-1, C-UL (equivalent to CAN/CSA-C22.2 No.62368-1, CAN/CSA-C22.2 No.60601-1), EN62368-1, EN60601-1 3rd, Complies with IEC60601-1-2 4th Ed., EN61558-2-16 (OVC III)				
	CONDUCTED NOISE	Complies with FCC-B, VCCI-B, CISPR32-B, EN55011-B, EN55032-B				
	HARMONIC ATTENUATOR	Complies with IEC61000-3-2 (class A)				
OTHERS	CASE SIZE/WEIGHT	76.2×38.1×127mm [3×1.5×5] (W×H×D) / 570g max				
	COOLING METHOD	Convection, Forced air (Require external fan), Conduction cooling				

- *1 The listed options may affect the published standard specifications. Please contact us for detailed product specification.
- *2 The current of input surge to a built-in EMI/EMS Filter (0.2ms or less) is excluded.
- *3 In the case of dynamic fluctuations, the specifications may not be met.
- *4 This is the value measured on measuring board with capacitor of 22 μ F and 0.1 μ F within 150mm from output terminal. Measured by 20MHz Oscilloscope or Ripple-Noise meter (KEISOKU-GIKEN:RM-104).
- *5 Drift is the change in DC output for an eight hours period after a half-hour warm-up at 25 $^{\circ}$ C, with the input voltage held constant at the rated input/output.
- *6 The output is shut down when the overcurrent protection continues.

- *7 Applicable when AUX and remote control (optional) is added.
- *8 Please contact us about another class.
- *9 The value at Ta=20 $^{\circ}$ C to +50 $^{\circ}$ C.
- *10 The value at rated load.
- * To meet the specifications. Do not operate over-loaded condition.
- * Parallel operation is not possible.
- * Sound noise may be generated by power supply in case of pulse load.
- * Forced air cooling is required to output up to MAX OUTPUT WATTAGE.

Features

- **Wattage 700W max**
- **High efficiency 96% typ (Input Voltage 230V, Output Voltage 24V)**
- **3" X 5" standard footprint**
- **Industrial and Medical safety approvals (Suitable for BF application)**
- **With Remote On/Off (Optional)**
- **Isolated dual AUX (AUX1 12V 1A, AUX2 5V 1A) (Optional)**

- **High Power density:31.1W/inch³**
- **Conduction cooling**
- **Fits 1U applications**
- **Low leakage current**
- **Complies with EN61558-2-16 (OVC III)**
- **Conformal coating (Optional)**

Block diagram

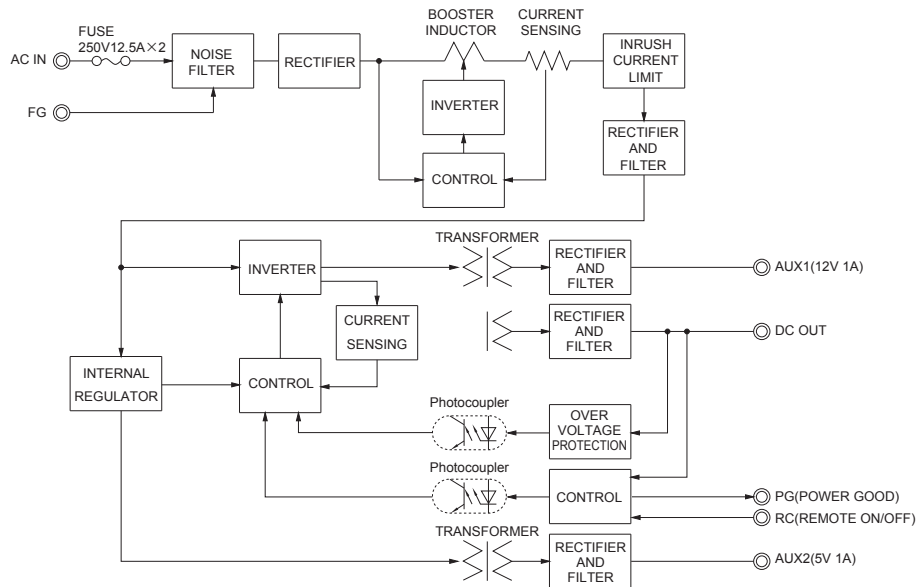

External view

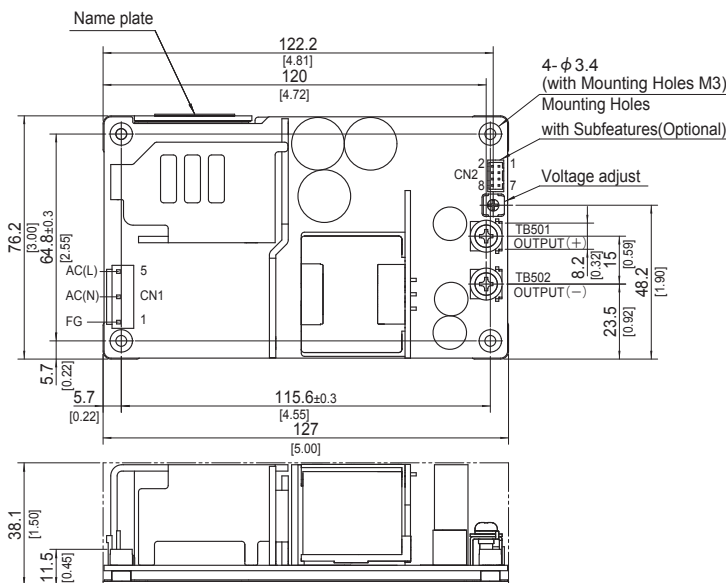

- ※ Tolerance $\pm 1 [\pm 0.04]$
- ※ Weight : 570g max
- ※ PCB Material / thickness : FR-4 / 1.7mm [0.07]
- ※ Chassis Material : Aluminum
- ※ Dimensions in mm, []=inches
- ※ Screw tightening torque : (TB501, 502) : M4 1.5N · m max
- ※ Mounting torque : M3 0.6N · m max
- ※ Avoid contact between TB501 and 502 wiring with mounting parts.

Connector	Mating connector	Terminal	Mfr
CN1	B3P5-VH	SVH-21T-P1.1 SVH-41T-P1.1	J.S.T.
CN2 *	B8B-PHDSS	SPHD-001T-P0.5 SPHD-002T-P0.5	

*Option: R3 or U1

<CN1>

Pin No.	Input
1	FG
2	
3	AC(N)
4	
3	AC(L)

*Pin No.2 and 4 is NC at CN1.

<CN2 (Option: R3)>

Pin No.	Function
1	AUX1 : AUX1 (12V1A)
2	AUX1G: AUX1 (GND)
3	RC : REMOTE ON/OFF
4	RCG : REMOTE ON/OFF (GND)
5	PG : Power good
6	PGG : Power good (GND)
7	AUX2 : AUX2 (5V1A)
8	AUX2G: AUX2 (GND)



CN2

*Please refer to instruction manual for the pin assignments of the option U1.

GHA300F-SNF

GH A 300 F -□□ -SNF□
 ① ② ③ ④ ⑤ ⑥

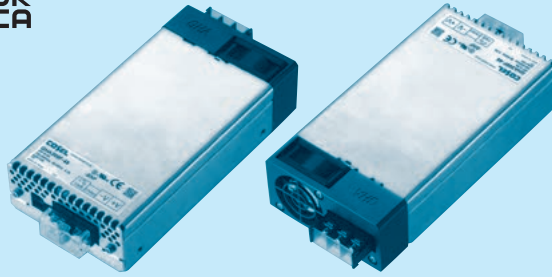

Example recommended EMI/EMC filter
EAC-10-472



High voltage pulse noise type : EAP series
 Low leakage current type : EAM series
 *A higher current rating EMI/EMC filter may be recommended in view of the other devices that could be connected in parallel with the power supply.

- ① Series name
 - ② Single output
 - ③ Output wattage
 - ④ Universal input
 - ⑤ Output voltage
 - ⑥ Optional *6
 - J1 : CN501
 PHconnector type(J.S.T.)
 - J2 : CN501
 Friction locks connector type (Molex)
- Refer to the instruction manual 6.1.

*Make sure necessary tests will be carried out on your end equipment with the power supply installed in accordance with any required EMC/EMI regulations.

MODEL	GHA300F-12-SNF	GHA300F-24-SNF	GHA300F-48-SNF
MAX OUTPUT WATTAGE[W]	300	300	302.4
DC OUTPUT	Forced air +50°C 12V 25.0A	24V 12.5A	48V 6.3A

SPECIFICATIONS

	MODEL	GHA300F-12-SNF	GHA300F-24-SNF	GHA300F-48-SNF	
INPUT	VOLTAGE[V]	AC90 - 264 1 φ (output derating is required at AC90V -115V *3)			
	CURRENT[A]	ACIN 120V	3.3typ		
		ACIN 230V	1.8typ		
	FREQUENCY[Hz]	50 / 60 (47 - 63)			
	EFFICIENCY[%]	ACIN 120V	88typ	89typ	89typ
		ACIN 230V	90typ	91typ	91typ
	POWER FACTOR (Io=100%)	ACIN 120V	0.95typ		
		ACIN 230V	0.90typ		
INRUSH CURRENT[A]	ACIN 120V	20typ (Io=100%) (At cold start) (Ta=25°C)			
	ACIN 230V	40typ (Io=100%) (At cold start) (Ta=25°C)			
LEAKAGE CURRENT[ma]	0.125/0.250max (ACIN 120V/240V 60Hz,Io=100%, According to IEC60601-1)				
OUTPUT	VOLTAGE[V]	12	24	48	
	CURRENT[A]	Forced air 25.0	12.5	6.3	
	LINE REGULATION[mV]	*4 48max	96max	192max	
	LOAD REGULATION[mV]	*4 100max	150max	240max	
	RIPPLE[mVp-p] *1	0 to +50°C	240max	240max	300max
		-20 - 0°C	320max	320max	400max
	RIPPLE NOISE[mVp-p]*1	0 to +50°C	300max	300max	480max
		-20 - 0°C	360max	360max	500max
	TEMPERATURE REGULATION[mV]	0 to +50°C	120max	240max	480max
		-20 to +50°C	150max	290max	600max
	DRIFT[mV]	*2 48max	96max	192max	
	START-UP TIME[ms]	500typ (ACIN 120V, Io=100%)			
	HOLD-UP TIME[ms]	16typ (ACIN 120V, Io=100%)			
	OUTPUT VOLTAGE ADJUSTMENT RANGE[V]	10.80 to 13.20	21.60 to 26.40	43.20 to 52.80	
OUTPUT VOLTAGE SETTING[V]	12.00 to 12.48	24.00 to 24.96	48.00 to 49.92		
PROTECTION CIRCUIT AND OTHERS	OVERCURRENT PROTECTION	Works over 105% of rating and recovers automatically *7			
	OVERVOLTAGE PROTECTION[V]	13.80 to 16.80	27.60 to 33.60	55.20 to 67.20	
	AUX1	10V 0.5A			
	AUX2	5V 1A			
	REMOTE ON/OFF	Possible, AUX2 is available			
PowerGood	Open collector				
ISOLATION	INPUT-OUTPUT · RC · AUX	AC4,000V 1minute, Cutoff current = 10mA, DC500V 50MΩ min (At Room Temperature) 2MOPP			
	INPUT-FG	AC2,000V 1minute, Cutoff current = 10mA, DC500V 50MΩ min (At Room Temperature) 1MOPP			
	OUTPUT · RC · AUX-FG	AC500V 1minute, Cutoff current = 25mA, DC500V 50MΩ min (At Room Temperature)			
	OUTPUT-RC · AUX	AC500V 1minute, Cutoff current = 25mA, DC500V 50MΩ min (At Room Temperature)			
ENVIRONMENT	OPERATING TEMP.,HUMID.AND ALTITUDE	-20 to +70°C, 20 - 90%RH (Non condensing), 3,000m (10,000feet) max *3			
	STORAGE TEMP.,HUMID.AND ALTITUDE	-30 to +75°C, 20 - 90%RH (Non condensing), 9,000m (30,000feet) max			
	VIBRATION	10 - 55Hz, 19.6m/s ² (2G), 3minutes period, 60minutes each along X, Y and Z axis			
	IMPACT	196.1m/s ² (20G), 11ms, once each X, Y and Z axis			
SAFETY AND NOISE REGULATIONS	AGENCY APPROVALS	UL60950-1, ANSI/AAMI ES60601-1, C-UL(CSA60950-1, CAN/CSA60601-1), EN62368-1, EN60601-1 3rd, Complies with DEN-AN, IEC60601-1-2 4th Ed.			
	CONDUCTED NOISE	Complies with FCC-B, VCCI-B, CISPR11-B, CISPR22-B, EN55011-B, EN55022-B			
	HARMONIC ATTENUATOR	Complies with IEC61000-3-2 (class A) *5			
OTHERS	CASE SIZE/WEIGHT	85.2 X 41 X 165.3mm [3.35 X 1.61 X 6.5 inches] (W X H X D) / 620g max			
	COOLING METHOD	Forced air			

*1 This is the value that measured on measuring board with capacitor of 22 μF at 150mm from output terminal.

Measured by 20MHz oscilloscope or Ripple-Noise meter (Equivalent to KEISOKU-GIKEN: RM103).

*2 Drift is the change in DC output for an eight hour period after a half-hour warm-up at 25°C, with the input voltage held constant at the rated input/output.

*3 Refer to "Derating".

*4 Please contact us about dynamic load and input response.

*5 Please contact us about another class.

*6 Specification is changed at option, refer to Instruction Manual.

*7 When output current more than rated, output will shut down after 5 seconds or more. Recycle input after 3 minutes to reset the protection.

* To meet the specifications. Do not operate over-loaded condition.

* Sound noise may be generated by power supply in case of pulse load.

GHA500F-SNF

GH A 500 F -□□ -SNF□
 ① ② ③ ④ ⑤ ⑥

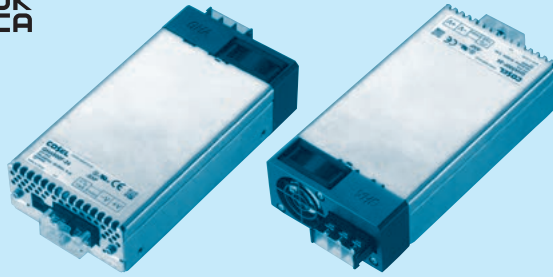

Example recommended EMI/EMC filter
EAC-10-472



High voltage pulse noise type : EAP series
 Low leakage current type : EAM series
 * A higher current rating EMI/EMC filter may be recommended in view of the other devices that could be connected in parallel with the power supply.

- ① Series name
 - ② Single output
 - ③ Output wattage
 - ④ Universal input
 - ⑤ Output voltage
 - ⑥ Optional *6
- J1 : CN501
 PHconnector type(J.S.T.)
 J2 : CN501
 Friction locks connector type (Molex)
 P : Parallel Operation
- Refer to the instruction manual 6.1.

*Make sure necessary tests will be carried out on your end equipment with the power supply installed in accordance with any required EMC/EMI regulations.

MODEL	GHA500F-12-SNF	GHA500F-15-SNF	GHA500F-24-SNF	GHA500F-30-SNF	GHA500F-48-SNF	GHA500F-56-SNF	
MAX OUTPUT WATTAGE[W]	450	501	504	501	504	504	
DC OUTPUT	Forced air +50°C	12V 37.5A	15V 33.4A	24V 21.0A	30V 16.7A	48V 10.5A	56V 9.0A

SPECIFICATIONS

	MODEL	GHA500F-12-SNF	GHA500F-15-SNF	GHA500F-24-SNF	GHA500F-30-SNF	GHA500F-48-SNF	GHA500F-56-SNF					
INPUT	VOLTAGE[V]	AC90 - 264 1 φ (output derating is required at AC90V -115V *3)										
	CURRENT[A]	ACIN 120V	4.8typ	5.4typ								
		ACIN 230V	2.6typ	2.9typ								
	FREQUENCY[Hz]	50 / 60 (47 - 63)										
	EFFICIENCY[%]	ACIN 120V	87typ	89typ	89typ	89typ	89typ					
		ACIN 230V	89typ	91typ	91typ	91typ	91typ					
	POWER FACTOR (Io=100%)	ACIN 120V	0.95typ									
		ACIN 230V	0.90typ									
INRUSH CURRENT[A]	ACIN 120V	20typ (Io=100%) (At cold start) (Ta=25°C)										
	ACIN 230V	40typ (Io=100%) (At cold start) (Ta=25°C)										
LEAKAGE CURRENT[mA]	0.125/0.250max (ACIN 120V/240V 60Hz,Io=100%, According to IEC60601-1)											
OUTPUT	VOLTAGE[V]	12	15	24	30	48	56					
	CURRENT[A]	Forced air	37.5	33.4	21.0	16.7	10.5	9.0				
	LINE REGULATION[mV]	*4	48max	60max	96max	120max	192max	192max				
	LOAD REGULATION[mV]	*4	100max	120max	150max	180max	240max	240max				
	RIPPLE[mVp-p]	*1	0 to +50°C	240max	240max	240max	300max	300max	400max			
		-20 - 0°C	320max	320max	320max	400max	400max	500max				
	RIPPLE NOISE[mVp-p]*1	0 to +50°C	300max	300max	300max	480max	480max	500max				
		-20 - 0°C	360max	360max	360max	500max	500max	580max				
	TEMPERATURE REGULATION[mV]	0 to +50°C	120max	150max	240max	300max	480max	480max				
		-20 to +50°C	150max	180max	290max	360max	600max	600max				
	DRIFT[mV]	*2	48max	60max	96max	120max	192max	192max				
	START-UP TIME[ms]	500typ (ACIN 120V, Io=100%)										
	HOLD-UP TIME[ms]	16typ (ACIN 120V, Io=100%)										
OUTPUT VOLTAGE ADJUSTMENT RANGE[V]	10.80 to 13.20		13.50 to 16.50		21.60 to 26.40		27.00 to 31.50		43.20 to 52.80		52.00 to 56.00	
OUTPUT VOLTAGE SETTING[V]	12.00 to 12.48		15.00 to 15.30		24.00 to 24.96		30.00 to 31.20		48.00 to 49.92		55.00 to 56.00	
PROTECTION CIRCUIT AND OTHERS	OVERCURRENT PROTECTION	Works over 105% of rating and recovers automatically *7										
	OVERVOLTAGE PROTECTION[V]	13.80 to 16.80	17.25 to 21.00	27.60 to 33.60	34.50 to 42.00	55.20 to 67.20	60.00 to 69.00					
	AUX1	12V 0.5A										
	AUX2	5V 1A										
	REMOTE ON/OFF	Possible, AUX2 is available										
	PowerGood	Open collector										
ISOLATION	INPUT-OUTPUT · RC · AUX	AC4,000V 1minute, Cutoff current = 10mA, DC500V 50MΩ min (At Room Temperature) 2MOPP										
	INPUT-FG	AC2,000V 1minute, Cutoff current = 10mA, DC500V 50MΩ min (At Room Temperature) 1MOPP										
	OUTPUT · RC · AUX-FG	AC500V 1minute, Cutoff current = 25mA, DC500V 50MΩ min (At Room Temperature)										
	OUTPUT-RC · AUX	AC500V 1minute, Cutoff current = 25mA, DC500V 50MΩ min (At Room Temperature)										
ENVIRONMENT	OPERATING TEMP.,HUMID.AND ALTITUDE	-20 to +70°C, 20 - 90%RH (Non condensing), 3,000m (10,000feet) max *3										
	STORAGE TEMP.,HUMID.AND ALTITUDE	-30 to +80°C, 20 - 90%RH (Non condensing), 9,000m (30,000feet) max										
	VIBRATION	10 - 55Hz, 19.6m/s ² (2G), 3minutes period, 60minutes each along X, Y and Z axis										
	IMPACT	196.1m/s ² (20G), 11ms, once each X, Y and Z axis										
SAFETY AND NOISE REGULATIONS	AGENCY APPROVALS	UL60950-1, ANSI/AAMI ES60601-1, C-UL(CSA60950-1, CAN/CSA60601-1), EN62368-1, EN60601-1 3rd, Complies with DEN-AN, IEC60601-1-2 4th Ed.										
	CONDUCTED NOISE	Complies with FCC-B, VCCI-B, CISPR11-B, CISPR22-B, EN55011-B, EN55022-B										
	HARMONIC ATTENUATOR	Complies with IEC61000-3-2 (class A) *5										
OTHERS	CASE SIZE/WEIGHT	85.2 X 41 X 165.3mm [3.35 X 1.61 X 6.5 inches] (W X H X D) / 660g max										
	COOLING METHOD	Forced air										

*1 This is the value that measured on measuring board with capacitor of 22 μF at 150mm from output terminal.
 Measured by 20MHz oscilloscope or Ripple-Noise meter (Equivalent to KEISOKU-GIKEN: RM103).
 *2 Drift is the change in DC output for an eight hour period after a half-hour warm-up at 25°C, with the input voltage held constant at the rated input/output.
 *3 Refer to "Derating".
 *4 Please contact us about dynamic load and input response.

*5 Please contact us about another class.
 *6 Specification is changed at option, refer to Instruction Manual.
 *7 When output current more than rated, output will shut down after 5 seconds or more. Recycle input after 3 minutes to reset the protection.
 * To meet the specifications. Do not operate over-loaded condition.
 * Sound noise may be generated by power supply in case of pulse load.
 * Parallel operation is available with -P option. Refer to 5.1on the instruction manual.

Features

- Full packaged design united with GHA's features, and additional robustness..
- High efficiency 91% typ (Input voltage 230V,Output voltage 24V)
- 50% minimized size compares with previous products.
- Optical for 1U applications
- Medical and Industrial safety approvals
- Low leakage current
- Conformal coating
- Single remote ON/OFF control for DC output, AUX1 and Fan.
- Isolated dual AUX (AUX1 12V 0.5A, AUX2 5V 1A)

Block diagram

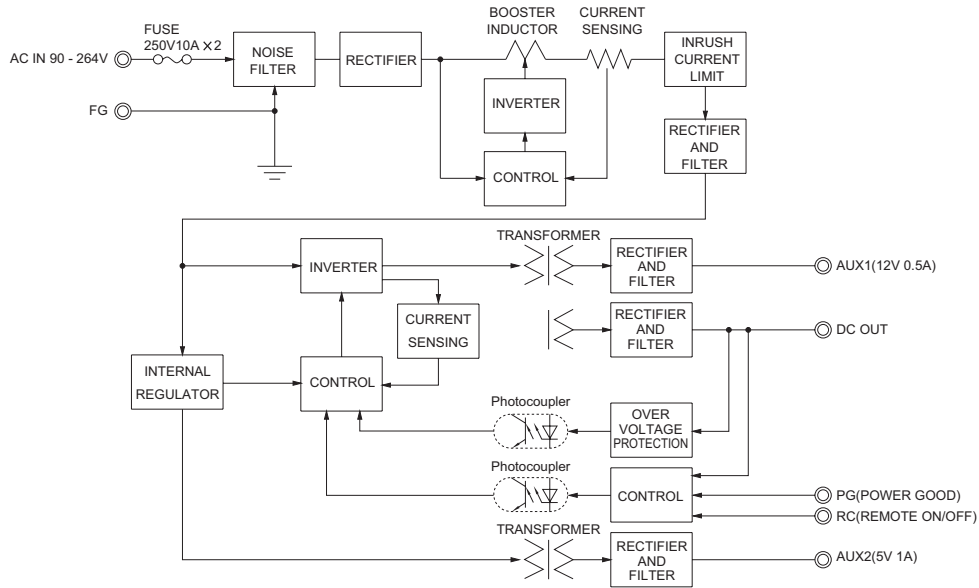

External view

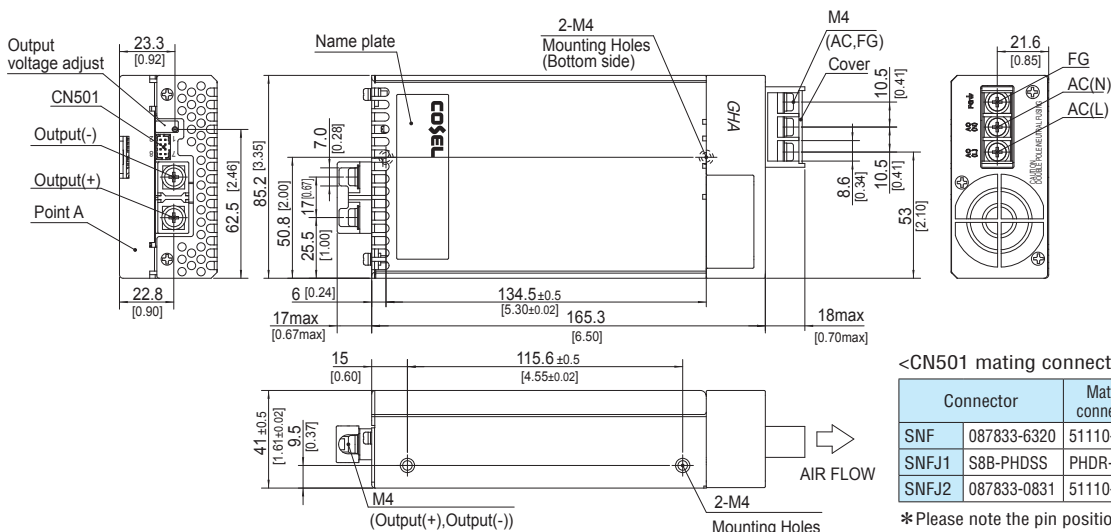

- ※ Tolerance ± 1 [±0.04]
- ※ Weight : 660g max
- ※ Upper PCB Material/thickness : FR-4/1.6mm
- ※ Lower PCB Material/thickness : AL/1.5mm
- ※ Chassis Material/thickness : Aluminum/1.5mm
- ※ Cover Material/thickness : Aluminum/1.2mm
- ※ Fan cover Material : PBT
- ※ Mounting torque : 1.5N · m (14.7kgf · cm) max
- ※ Screw tightening torque M4 : 1.6N · m (16.9kgf · cm) max
- ※ Dimensions in mm, []=inches

<CN501 mating connector and terminal>

Connector	Mating connector	Terminal	Mfr
SNF	087833-6320	51110-0851	50394-8051 Molex *
SNFJ1	S8B-PHDSS	PHDR-08VS	SPHD-002T-P0.5 J.S.T.
SNFJ2	087833-0831	51110-0860	50394-8051 Molex *

* Please note the pin position No.1 is different from Molex.

<CN501>

Pin No.	Function
1	AUX1 : AUX1 (12V0.5A)
2	AUX1G : AUX1 (GND)
3	RC : REMOTE ON/OFF
4	RCG : REMOTE ON/OFF (GND)
5	PG : Power good
6	PGG : Power good (GND)
7	AUX2 : AUX2 (5V1A)
8	AUX2G : AUX2 (GND)



Assembling and Installation Method

● GHA300/500F

■ Mounting method

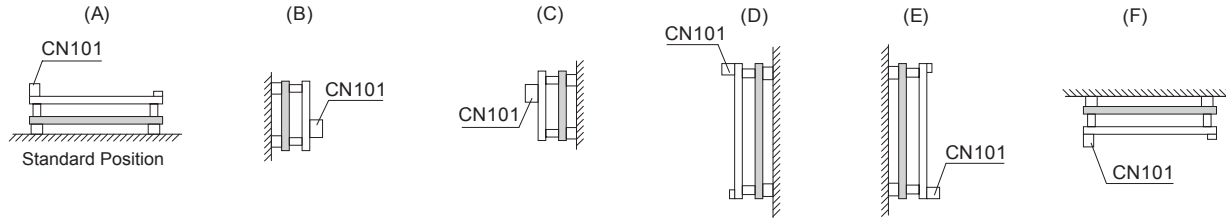

● GHA700F

■ Mounting method

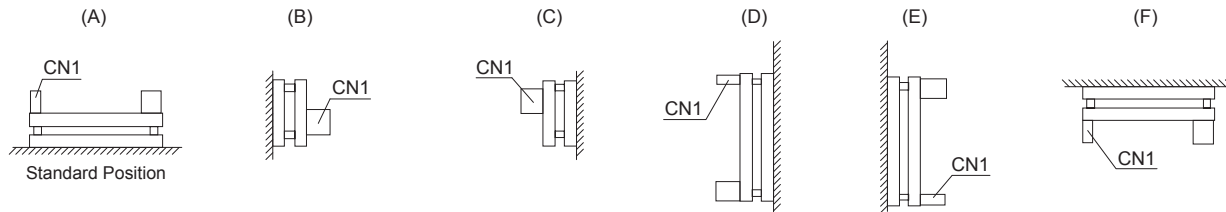

■ AC voltage exist on the primary side therefore. In order to prevent electric shock, or to meet the leakage current requirements of the safety standard, you need to ensure the proper insulation distance.

■ During use, keep the distance between d1 & d2 for to insulate between lead of component and metal chassis, use the spacer of 5mm or more between d2. If it is less than d1 & d2, insert the insulation sheet between power supply and metal chassis.

● GHA300F

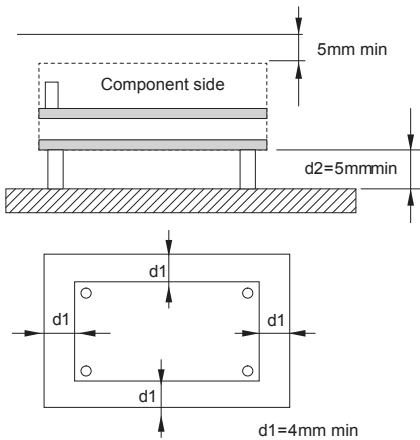

● GHA500F

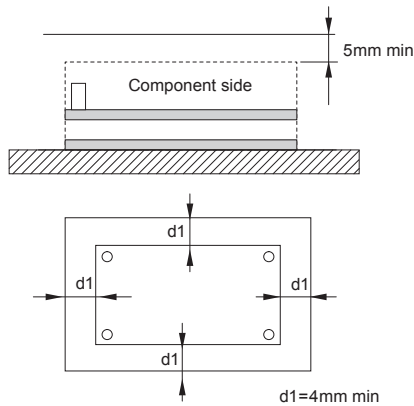

● GHA700F

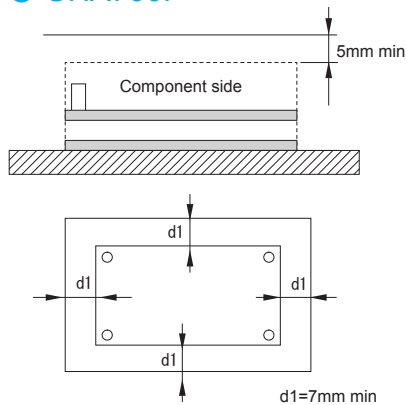

GHA

Assembling and Installation Method

Remarks:

There is a possibility that it is not possible to cool enough when the power supply is used by the sealing up space as showing in right figure.

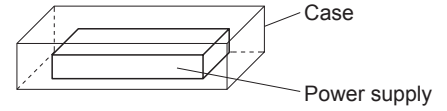

GHA300/500F-SNF

■ Mounting screw

Screw length into power supply should be shorter than 6mm due to keep safety isolation clearance from inside components in right figure. Please fix power supply surely by screws in consideration of the weight.

■ A cooling FAN is built-in. Please keep 30mm or more clearance both input and output side to make enough air ventilation. Do not block off cooling FAN's air flow for stable operation.

■ When power supply is used where dust exist, it may cause of FAN failure. It is recommended to install a air filter to the system air ventilation duct.

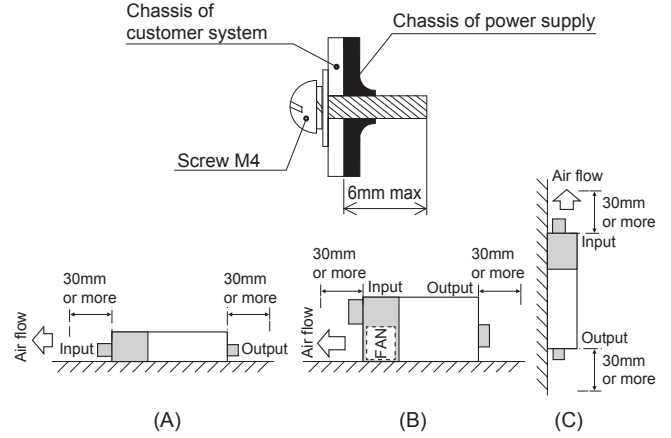

Mounting screw

■ The mounting screw should be M3. The hatched area shows the allowance of metal parts for mounting.

■ If metallic fittings are used on the component side of the board, ensure there is no contact with surface mounted components.

■ This product uses SMD technology. Please avoid the PCB installation method which includes the twisting stress or the bending stress.

GHA300/500F

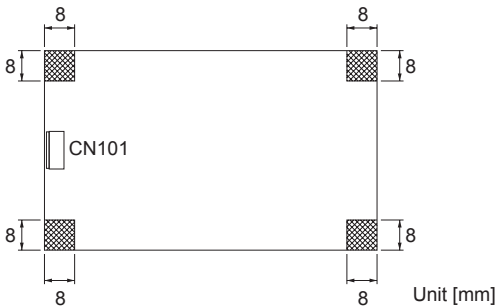

GHA700F

* The center of $\phi 7$ mm is the same point as the center of the mounting hole.

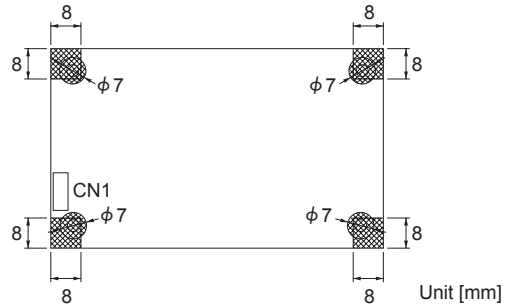

Derating

■ Cooling method

Conduction cooling, forced air and convection cooling are available for GHA500F and GHA700F. Both Forced air and convection cooling are available for GHA300F. Please see instruction manual 3 for details. Please make sure the maximum component temperature rise given in instruction manual 3 is not exceeded.

GHA300/500F

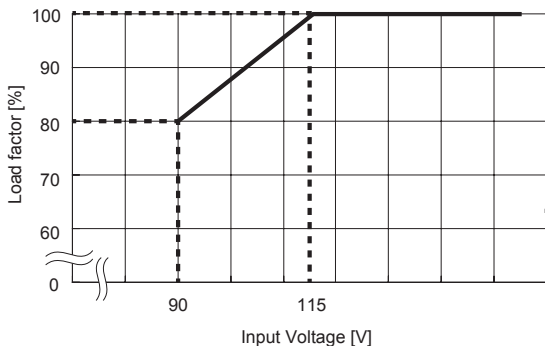

* For maximum power in each cooling method, please apply.

GHA700F

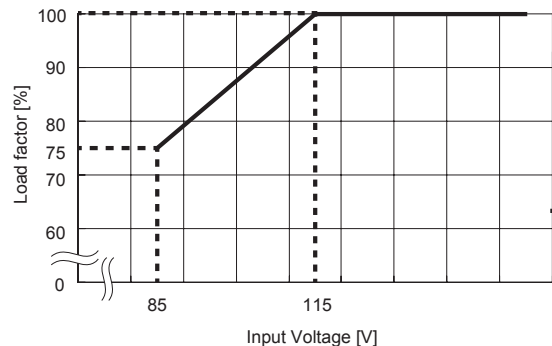

* For maximum power in each cooling method, please apply.

Derating

● GHA500F Ambient temperature derating curve at forced air (Reference value)

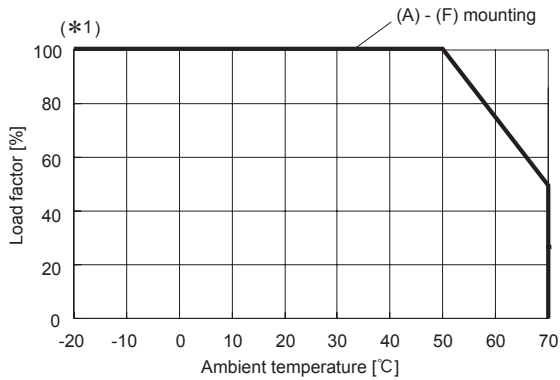

*For the derating curves of other heat dissipation methods, see instruction manual 3.

*1 The maximum output power by wind speed conditions (Reference value)

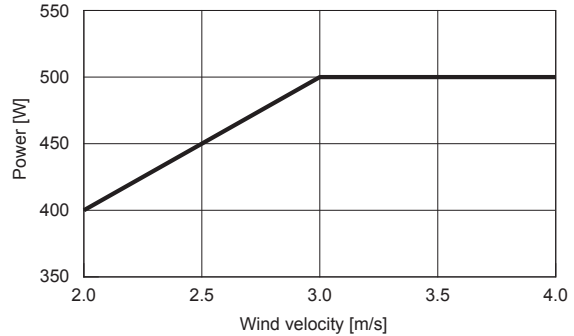

● GHA300F Ambient temperature derating curve at forced air (Reference value)

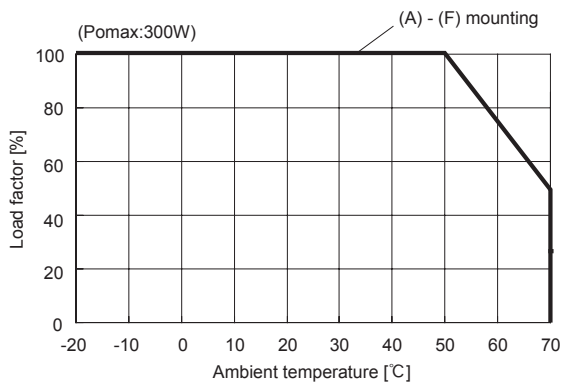

*For the derating curves of other heat dissipation methods, see instruction manual 3.

● GHA300/500F-SNF Ambient temperature derating curve (Reference value)

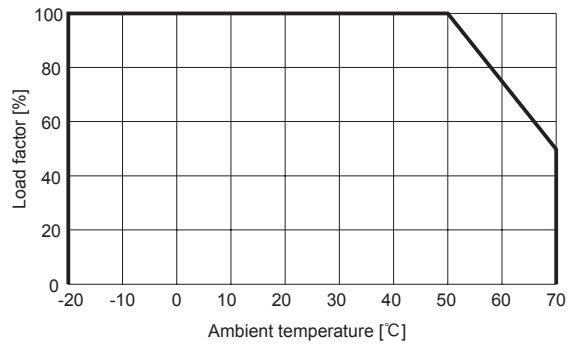

● GHA700F Ambient temperature derating curve at forced air (Reference value)

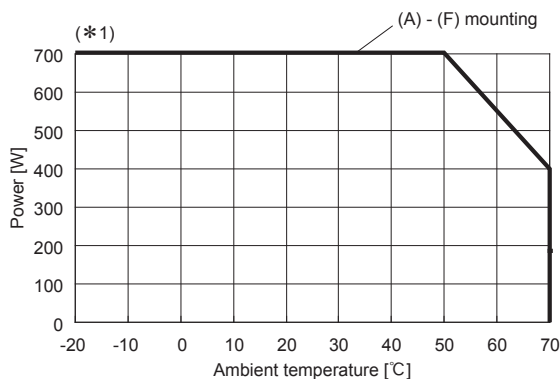

*For the derating curves of other heat dissipation methods, see instruction manual 3.

*1 The maximum output power by wind speed conditions (Reference value)

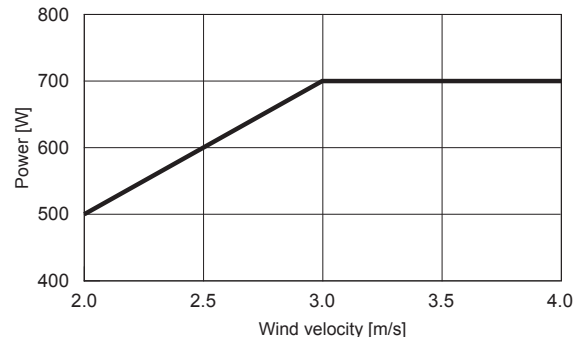

Instruction Manual

- ◆ It is necessary to read the “Instruction Manual” and “Before using our product” before you use our product.

Instruction Manual <https://www.cosel.co.jp/redirect/catalog/en/GHA/>
 Before using our product <https://en.cosel.co.jp/technical/caution/index.html>

GHA



NOTICE



Basic Characteristics Data

Model	Circuit method	Switching frequency [kHz]	Input current *1 [A]	Inrush current protection	PCB/Pattern			Series/Parallel operation availability	
					Material	Single sided	Double sided	Series operation	Parallel operation
GHA300F	boost chopper	60 - 220	3.3	Thermistor	FR-4	—	Yes	Yes	No
	LLC resonant converters	90 - 180							
GHA500F	boost chopper	60 - 220	5.4	Thermistor	Aluminum/FR-4	Yes	Yes	Yes	*2
	LLC resonant converters	90 - 180							
GHA700F	boost chopper	55 - 75	6.3	Thermistor	FR-4	—	Yes	Yes	No
	LLC resonant converters	45 - 370							
GHA300F-SNF	boost chopper	60 - 220	3.3	Thermistor	FR-4	Yes	Yes	Yes	No
	LLC resonant converters	90 - 180							
GHA500F-SNF	boost chopper	60 - 220	5.4	Thermistor	Aluminum/FR-4	Yes	Yes	Yes	*2
	LLC resonant converters	90 - 180							

*1 The value of input current is at ACIN 120V and rated load.

*2 Parallel operation is available with -P option. Refer to 6.1 on the instruction manual.



PJMA-series

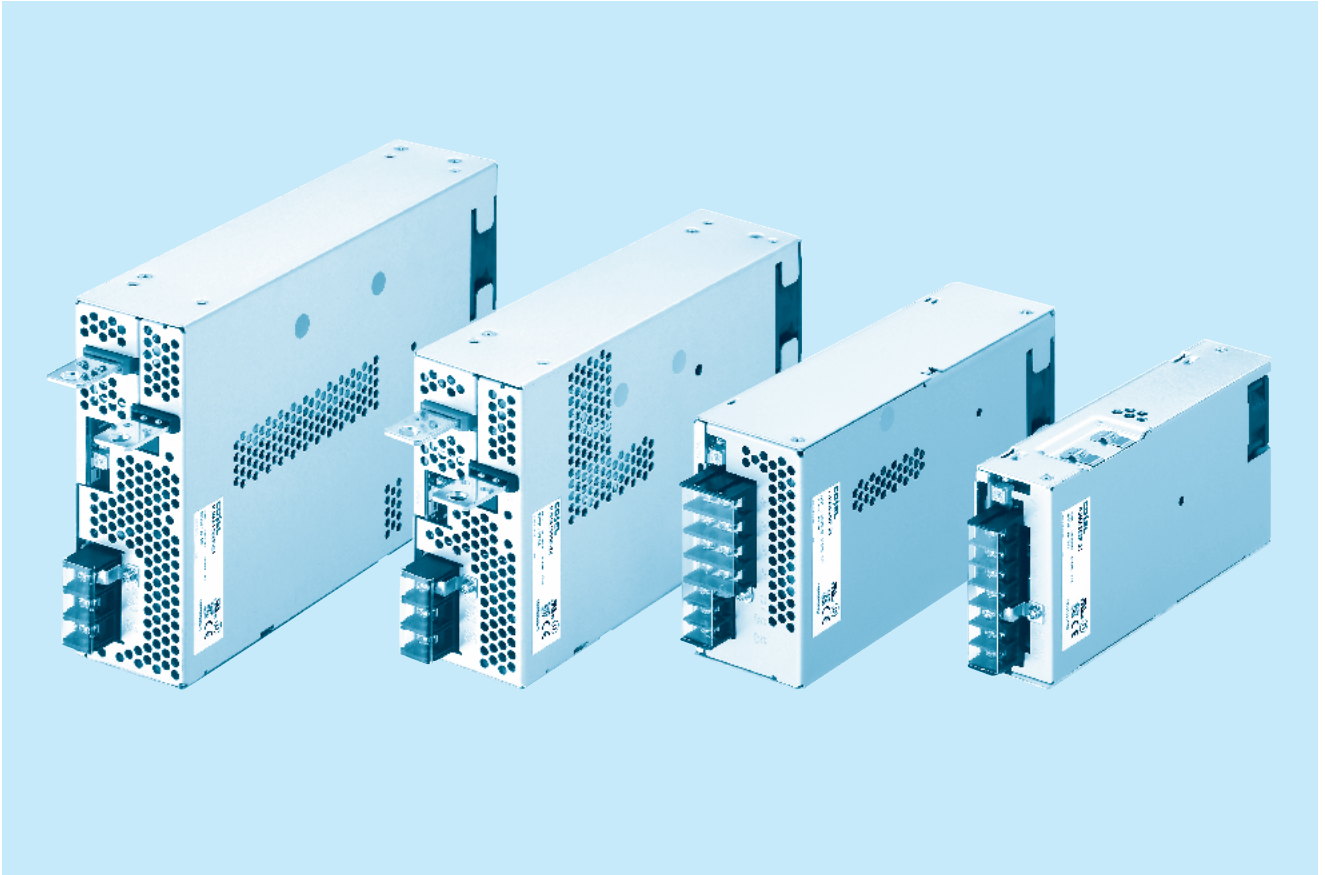

Feature

- 4kV isolation
- Economical design
- Suitable for BF application (Output-FG : 1MOPP, Input-Output : 2MOPP)
- Wide temperature range (-20°C to +70°C, Derating is required)
- Harmonic attenuator (Complies with IEC61000-3-2 class A)
- Universal input (AC85 - 264V, Derating is required)
- Low power consumption at no load

Safety agency approvals

ANSI/AAMI ES60601-1, EN60601-1 3rd

5-year warranty (See Instruction Manual)

CE marking

Low Voltage Directive
RoHS Directive

EMI

Complies with FCC-B, CISPR32-B, EN55011-B, EN55032-B, VCCI-B
(PJMA1500F: Class A. In conducted noise, it can meet class B by additional EMI/EMC filter.)

EMS Compliance : EN61204-3, EN61000-6-2

IEC60601-1-2 (2014), IEC60601-1-2 (2015)

EN61000-4-2
EN61000-4-3
EN61000-4-4
EN61000-4-5
EN61000-4-6
EN61000-4-8
EN61000-4-11

PJMA300F

PJM A 300 F -□ -□
 ① ② ③ ④ ⑤ ⑥

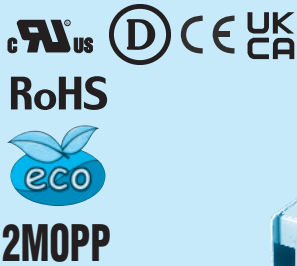

Example recommended EM/EMC filter
NAC-06-472



High voltage pulse noise type : NAP series
 Low leakage current type : NAM series
 * A higher current rating EM/EMC filter may be recommended in view of the other devices that could be connected in parallel with the power supply.

- ① Series name
- ② Single output
- ③ Output wattage
- ④ Universal input
- ⑤ Output voltage
- ⑥ Optional *6
- C : with Coating
- G : Low leakage current
- V : External potentiometer for output voltage adjustment
- R : Remote on/off (Required external power source)
- F4: Low speed fan

See 5.1 in Instruction Manual.

*Make sure necessary tests will be carried out on your end equipment with the power supply installed in accordance with any required EMC/EMI regulations.

SPECIFICATIONS

	MODEL	PJMA300F-12	PJMA300F-24	PJMA300F-36	PJMA300F-48	
INPUT	VOLTAGE[V]	AC85 - 264 1 φ (Output derating is required at AC85V - 100V. Refer to "Derating" and instruction manual 1.1)				
	CURRENT[A]	ACIN 100V	3.9typ (Io=100%)			
		ACIN 115V	3.3typ (Io=100%)			
		ACIN 230V	1.7typ (Io=100%)			
	FREQUENCY[Hz]	50 / 60 (47 - 63)				
	EFFICIENCY[%]	ACIN 100V	79typ (Io=100%)		82typ (Io=100%)	
		ACIN 115V	80typ (Io=100%)		83typ (Io=100%)	
		ACIN 230V	82typ (Io=100%)		86typ (Io=100%)	
	POWER FACTOR	ACIN 100V	0.99typ (Io=100%)		83typ (Io=100%)	
		ACIN 115V	0.98typ (Io=100%)		83typ (Io=100%)	
ACIN 230V		0.95typ (Io=100%)		87typ (Io=100%)		
INRUSH CURRENT[A]	ACIN 100V	20typ (Io=100%) TA=25°C at cold start		82typ (Io=100%)		
	ACIN 115V	20typ (Io=100%) TA=25°C at cold start		83typ (Io=100%)		
	ACIN 230V	40typ (Io=100%) TA=25°C at cold start		86typ (Io=100%)		
LEAKAGE CURRENT[mA]	0.3max (ACIN 240V, 60Hz, Io=100%)					
OUTPUT	VOLTAGE[V]	12	24	36	48	
	CURRENT[A]	ACIN 85-100V	Output derating is required at ACIN 100V or less (Refer to "Derating")			
		ACIN 100V-264V	25	12.5	8.4	6.3
	WATTAGE[W]	ACIN 85-100V	Output derating is required at ACIN 100V or less (Refer to "Derating")			
		ACIN 100V-264V	300	300	302.4	302.4
	LINE REGULATION[mV]	*3	48max	96max	144max	192max
	LOAD REGULATION[mV]	*3	100max	150max	150max	300max
	RIPPLE[mVp-p]	0 to +50°C	120max	120max	150max	150max
		*1 -10 to 0°C	160max	160max	160max	400max
	RIPPLE NOISE[mVp-p]	0 to +50°C	150max	150max	200max	200max
		*1 -10 to 0°C	180max	180max	240max	500max
	TEMPERATURE REGULATION[mV]	0 to +50°C	120max	240max	360max	480max
		-10 to +50°C	180max	290max	440max	600max
	DRIFT[mV]	*2	48max	96max	144max	192max
	START-UP TIME[ms]	300typ (ACIN 100V, Io=100%)				
	HOLD-UP TIME[ms]	20typ (ACIN 100V, Io=100%)				
	OUTPUT VOLTAGE ADJUSTMENT RANGE[V]	10.80 to 13.20		21.60 to 26.40	32.40 to 39.60	43.20 to 52.80
OUTPUT VOLTAGE SETTING[V]	12.00 to 12.48		24.00 to 24.96	36.00 to 37.44	48.00 to 49.92	
PROTECTION CIRCUIT AND OTHERS	OVERCURRENT PROTECTION	Works over 105% of rating and recovers automatically				
	OVERVOLTAGE PROTECTION[V]	13.80 to 16.80	27.60 to 33.60	41.40 to 50.40	55.20 to 67.20	
	OPERATING INDICATION	LED (Green)				
	REMOTE SENSING	Not provided				
REMOTE ON/OFF	Optional (Required external power source. Option -R)					
ISOLATION	INPUT-OUTPUT • RC	*9 AC4,000V 1minute, Cutoff=20mA, 2MOPP DC500V 50MΩmin (At room temperature)				
	INPUT-FG	AC2,000V 1minute, Cutoff=20mA, 1MOPP DC500V 50MΩmin (At room temperature)				
	OUTPUT • RC-FG	*9 AC1,500V 1minute, Cutoff=20mA, 1MOPP DC500V 50MΩmin (At room temperature)				
	OUTPUT-RC	*9 AC500V 1minute, Cutoff=20mA, DC500V 50MΩmin (At room temperature)				
ENVIRONMENT	OPERATING TEMP.,HUMID.AND ALTITUDE**	-20 to +70°C (Refer to "Derating"), 20 - 90%RH (Non condensing), 3,000m (10,000 feet) max				
	STORAGE TEMP.,HUMID.AND ALTITUDE	-20 to +75°C, 20 - 90%RH (Non condensing), 9,000m (30,000 feet) max				
	VIBRATION	10 - 55Hz, 19.6m/s ² (2G), 3minutes period, 60 minutes each along X, Y and Z axes				
SAFETY AND NOISE REGULATIONS	IMPACT	196.1m/s ² (20G), 11ms, once each X, Y and Z axes				
	AGENCY APPROVALS	ANSI/AAMI ES60601-1, EN60601-1 3rd				
	CONDUCTED NOISE	Complies with FCC-B, VCCI-B, CISPR22-B, EN55011-B, EN55022-B				
	HARMONIC ATTENUATOR *8	Complies with IEC61000-3-2 class A				

SPECIFICATIONS

OTHERS	CASE SIZE/WEIGHT	102 X 41 X 190mm [4.02 X 1.61 X 7.48 inches] (Excluding terminal block and screw) (W X H X D) / 1.0kg max
	COOLING METHOD	*7 Forced cooling (internal fan)
WARRANTY	WARRANTY	*5 5 years (subject to the operating conditions)

- *1 This is the result of measurement of the testing board with capacitors of 22 μF and 0.1 μF placed at 150 mm from the output terminals by a 20 MHz oscilloscope or a ripple-noise meter equivalent to Keisoku-Giken R104.
See 1.6 of Instruction Manual for more details.
- *2 Drift is the change in DC output for an eight hour period after a half-hour warm-up at 25°C.
- *3 Consult us about dynamic load and input response.
- *4 Output power derating is required. Refer to "Derating".
- *5 See 4 in Instruction Manual for more details.
- *6 Consult us about safety agency approvals for the models with optional functions.
- *7 The fan speed slows down at no load.
- *8 Consult us about other classes.
- *9 The RC terminal is added to option -R models. The RC terminal is isolated from input, output, and FG.
- * Do not use the power supply in overcurrent conditions or in unspecified input voltage ranges. Otherwise the internal components may be damaged.
- * Parallel operation is not possible with this mode.
- * Sound noise may be heard from the power supply when used for pulse load.

Features

- 4kV isolation
- Economical design
- Suitable for BF application (Output-FG : 1MOPP, Input-Output : 2MOPP)
- Wide temperature range (-20°C to +70°C, Refer to "Derating")
- Harmonic attenuator (Complies with IEC61000-3-2 class A)
- Universal input (AC85 - 264V, Refer to "Derating")
- Low power consumption at no load

Block diagram

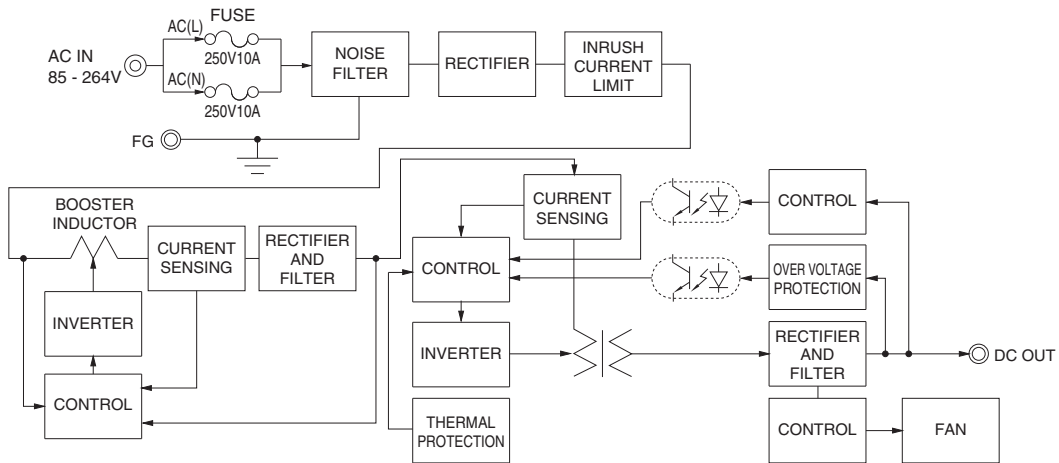

External view

The external size of -V option and -R option models is different from the standard model. See "5. Options and Others" in Instruction Manual for more details.

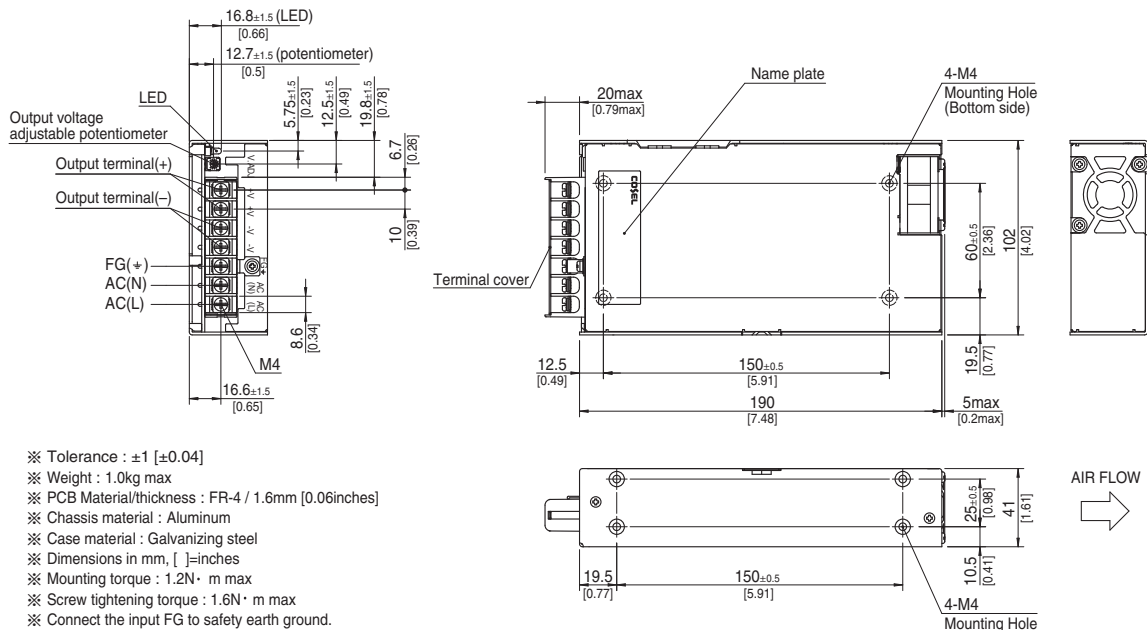

- ※ Tolerance : ±1 [±0.04]
- ※ Weight : 1.0kg max
- ※ PCB Material/thickness : FR-4 / 1.6mm [0.06inches]
- ※ Chassis material : Aluminum
- ※ Case material : Galvanizing steel
- ※ Dimensions in mm, []=inches
- ※ Mounting torque : 1.2N·m max
- ※ Screw tightening torque : 1.6N·m max
- ※ Connect the input FG to safety earth ground.

PJMA600F

PJM A 600 F -□ -□
 ① ② ③ ④ ⑤ ⑥

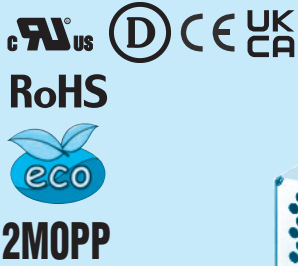

Example recommended EM/EMC filter
NAC-16-472



High voltage pulse noise type : NAP series
 Low leakage current type : NAM series
 * A higher current rating EM/EMC filter may be recommended in view of the other devices that could be connected in parallel with the power supply.

- ① Series name
 - ② Single output
 - ③ Output wattage
 - ④ Universal input
 - ⑤ Output voltage
 - ⑥ Optional *6
 - C : with Coating
 - G : Low leakage current
 - V : External potentiometer for output voltage adjustment
 - W1: LV alarm and Remote sensing
 - R : Remote on/off (Required external power source)
 - F4: Low speed fan
- See 5.1 in Instruction Manual.

*Make sure necessary tests will be carried out on your end equipment with the power supply installed in accordance with any required EMC/EMI regulations.

SPECIFICATIONS

	MODEL	PJMA600F-12	PJMA600F-24	PJMA600F-36	PJMA600F-48	
INPUT	VOLTAGE[V]	AC85 - 264 1 φ (Output derating is required at AC85V - 100V. Refer to "Derating" and instruction manual 1.1)				
	CURRENT[A]	ACIN 100V	7.5typ (Io=100%)			
		ACIN 115V	6.5typ (Io=100%)			
		ACIN 230V	3.2typ (Io=100%)			
	FREQUENCY[Hz]	50 / 60 (47 - 63)				
	EFFICIENCY[%]	ACIN 100V	81typ (Io=100%)		85typ (Io=100%)	
		ACIN 115V	82typ (Io=100%)		86typ (Io=100%)	
		ACIN 230V	84typ (Io=100%)		88typ (Io=100%)	
	POWER FACTOR	ACIN 100V	0.99typ (Io=100%)			
		ACIN 115V	0.98typ (Io=100%)			
ACIN 230V		0.95typ (Io=100%)				
INRUSH CURRENT[A]	ACIN 100V	20/40typ (Io=100%) (Primary inrush current /Secondary inrush current) (More than 3sec to re-start)				
	ACIN 115V	20/40typ (Io=100%) (Primary inrush current /Secondary inrush current) (More than 3sec to re-start)				
	ACIN 230V	40/40typ (Io=100%) (Primary inrush current /Secondary inrush current) (More than 3sec to re-start)				
LEAKAGE CURRENT[mA]	0.3max (ACIN 240V,60Hz,Io=100%)					
OUTPUT	VOLTAGE[V]	12	24	36	48	
	CURRENT[A]	ACIN 85-100V	Output derating is required at ACIN 100V or less (Refer to "Derating")			
		ACIN 100V-264V	50	25	16.7	12.5
	WATTAGE[W]	ACIN 85-100V	Output derating is required at ACIN 100V or less (Refer to "Derating")			
		ACIN 100V-264V	600	600	601.2	600
	LINE REGULATION[mV]	*7 48max	96max	144max	192max	
	LOAD REGULATION[mV]	*7 100max	150max	150max	300max	
	RIPPLE[mVp-p]	0 to +50°C	120max	120max	150max	150max
		*1 -20 to 0°C	160max	160max	160max	400max
	RIPPLE NOISE[mVp-p]	0 to +50°C	150max	150max	200max	200max
		*1 -20 to 0°C	180max	180max	240max	500max
	TEMPERATURE REGULATION[mV]	0 to +50°C	120max	240max	360max	480max
		*1 -20 to +50°C	180max	290max	440max	600max
	DRIFT[mV]	*2 48max	96max	144max	192max	
	START-UP TIME[ms]	300typ (ACIN 100V, Io=100%)				
HOLD-UP TIME[ms]	20typ (ACIN 100V, Io=100%)					
OUTPUT VOLTAGE ADJUSTMENT RANGE[V]	10.80 to 13.20		21.60 to 26.40	32.40 to 39.60	43.20 to 52.80	
OUTPUT VOLTAGE SETTING[V]	12.00 to 12.48		24.00 to 24.96	36.00 to 37.44	48.00 to 49.92	
PROTECTION CIRCUIT AND OTHERS	OVERCURRENT PROTECTION	Works over 105% of rating and recovers automatically				
	OVERVOLTAGE PROTECTION[V]	13.80 to 16.80	27.60 to 33.60	41.40 to 50.40	55.20 to 67.20	
	OPERATING INDICATION	LED (Green)				
	REMOTE SENSING	Optional (Option -W1)				
REMOTE ON/OFF	Optional (Required external power source. Option -R)					
ISOLATION	INPUT-OUTPUT • RC	*3 AC4,000V 1minute, Cutoff=20mA, 2MOPP DC500V 50MΩmin (At room temperature)				
	INPUT-FG	AC2,000V 1minute, Cutoff=20mA, 1MOPP DC500V 50MΩmin (At room temperature)				
	OUTPUT • RC-FG	*3 AC1,500V 1minute, Cutoff=20mA, 1MOPP DC500V 50MΩmin (At room temperature)				
	OUTPUT-RC	*3 AC500V 1minute, Cutoff=20mA, DC500V 50MΩmin (At room temperature)				
ENVIRONMENT	OPERATING TEMP.,HUMID.AND ALTITUDE	** -20 to +70°C (Refer to "Derating"), 20 - 90%RH (Non condensing), 3,000m (10,000 feet) max				
	STORAGE TEMP.,HUMID.AND ALTITUDE	-20 to +75°C, 20 - 90%RH (Non condensing), 9,000m (30,000 feet) max				
	VIBRATION	10 - 55Hz, 19.6m/s ² (2G), 3minutes period, 60minutes each along X, Y and Z axes				
SAFETY AND NOISE REGULATIONS	IMPACT	196.1m/s ² (20G), 11ms, once each X, Y and Z axes				
	AGENCY APPROVALS	ANSI/AAMI ES60601-1, EN60601-1 3rd				
	CONDUCTED NOISE	Complies with FCC-B, VCCI-B, CISPR32-B, EN55011-B, EN55032-B				
	HARMONIC ATTENUATOR	*9 Complies with IEC61000-3-2 class A				

PJMA1000F

PJM A 1000 F -□ -□
 ① ② ③ ④ ⑤ ⑥

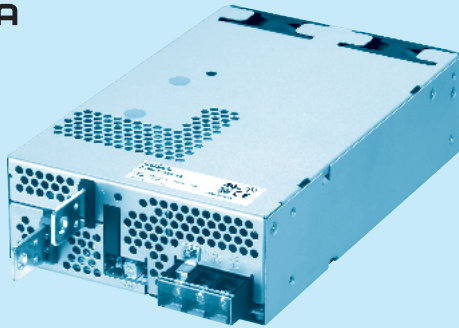
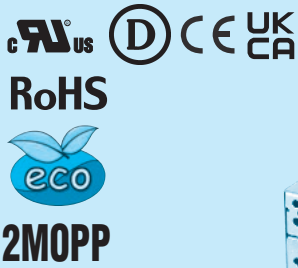

Example recommended EM/EMC filter
NAC-20-472



High voltage pulse noise type : NAP series
 Low leakage current type : NAM series

- ① Series name
- ② Single output
- ③ Output wattage
- ④ Universal input
- ⑤ Output voltage
- ⑥ Optional *8
- C : with Coating
- G : Low leakage current
- V : External potentiometer for output voltage adjustment
- W : Parallel operation, LV alarm and Remote sensing
- W1: LV alarm and Remote sensing
- R : Remote on/off (Required external power source)
- F4: Low speed fan

See 5.1 in Instruction Manual.

*Make sure necessary tests will be carried out on your end equipment with the power supply installed in accordance with any required EMC/EMI regulations.

SPECIFICATIONS

	MODEL	PJMA1000F-12	PJMA1000F-24	PJMA1000F-36	PJMA1000F-48	
INPUT	VOLTAGE[V]	AC85 - 264 1 φ (Output derating is required at AC85V - 115V. Refer to "Derating" and instruction manual 1.1)				
	CURRENT[A]	ACIN 100V	12.5typ (Io=90%)			
		ACIN 115V	11.0typ (Io=100%)			
		ACIN 230V	5.5typ (Io=100%)			
	FREQUENCY[Hz]	50 / 60 (47 - 63)				
	EFFICIENCY[%]	ACIN 100V	81typ (Io=90%)	84typ (Io=90%)	84typ (Io=90%)	84typ (Io=90%)
		ACIN 115V	82typ (Io=100%)	85typ (Io=100%)	85typ (Io=100%)	85typ (Io=100%)
ACIN 230V		85typ (Io=100%)	88typ (Io=100%)	88typ (Io=100%)	88typ (Io=100%)	
POWER FACTOR	ACIN 100V	0.98typ (Io=90%)				
	ACIN 115V	0.98typ (Io=100%)				
	ACIN 230V	0.95typ (Io=100%)				
INRUSH CURRENT[A]	ACIN 100V	15/30typ (Io=90%) (Primary inrush current /Secondary inrush current) (More than 10sec to re-start)				
	ACIN 115V	15/30typ (Io=100%) (Primary inrush current /Secondary inrush current) (More than 10sec to re-start)				
	ACIN 230V	30/30typ (Io=100%) (Primary inrush current /Secondary inrush current) (More than 10sec to re-start)				
LEAKAGE CURRENT[ma]	0.3max (ACIN 240V, 60Hz, Io=100%)					
OUTPUT	VOLTAGE[V]	12	24	36	48	
	CURRENT[A]	ACIN 85-115V	Output derating is required at ACIN 115V or less (Refer to "Derating")			
		ACIN 115V-264V	84	42	28	21
	WATTAGE[W]	ACIN 85-115V	Output derating is required at ACIN 115V or less (Refer to "Derating")			
		ACIN 115V-264V	1008	1008	1008	1008
	LINE REGULATION[mV]	*2 48max	96max	144max	192max	
	LOAD REGULATION[mV]	*2 100max	150max	150max	300max	
	RIPPLE[mVp-p]	0 to +50°C	180max	150max	150max	200max
		*1 -20 to 0°C	240max	160max	200max	500max
	RIPPLE NOISE[mVp-p]	0 to +50°C	210max	150max	200max	300max
		*1 -20 to 0°C	270max	180max	240max	600max
	TEMPERATURE REGULATION[mV]	0 to +50°C	120max	240max	360max	480max
		-20 to +50°C	180max	290max	440max	600max
	DRIFT[mV]	*3 48max	96max	144max	192max	
START-UP TIME[ms]	800typ (ACIN 115V, Io=100%)					
HOLD-UP TIME[ms]	20typ (ACIN 115V, Io=100%)					
OUTPUT VOLTAGE ADJUSTMENT RANGE[V]	10.80 to 13.50	20.40 to 28.50	30.60 to 40.80	40.80 to 55.20		
OUTPUT VOLTAGE SETTING[V]	12.00 to 12.48	24.00 to 24.96	36.00 to 37.44	48.00 to 49.92		
PROTECTION CIRCUIT AND OTHERS	OVERCURRENT PROTECTION	Works over 105% of rating and recovers automatically				
	OVERVOLTAGE PROTECTION[V]	14.40 to 17.40	28.80 to 34.80	43.20 to 52.20	57.00 to 67.20	
	OPERATING INDICATION	LED (Green)				
	REMOTE SENSING	Optional (Option -W, -W1)				
	REMOTE ON/OFF	Optional (Required external power source. Option -R)				
ISOLATION	INPUT-OUTPUT	AC4,000V 1minute, Cutoff=20mA, 2MOPP DC500V 50MΩ min (At room temperature)				
	INPUT-FG	AC2,000V 1minute, Cutoff=20mA, 1MOPP DC500V 50MΩ min (At room temperature)				
	OUTPUT · RC-FG	*3 AC1,500V 1minute, Cutoff=20mA, 1MOPP DC500V 50MΩ min (At room temperature)				
	OUTPUT-RC	AC500V 1minute, Cutoff=20mA, DC500V 50MΩ min (At room temperature)				
ENVIRONMENT	OPERATING TEMP., HUMID. AND ALTITUDE *4	-20 to +70°C (Refer to "Derating"), 20 - 90%RH (Non condensing), 3,000m (10,000 feet) max				
	STORAGE TEMP., HUMID. AND ALTITUDE	-20 to +75°C, 20 - 90%RH (Non condensing), 9,000m (30,000 feet) max				
	VIBRATION	10 - 55Hz, 19.6m/s ² (2G), 3minutes period, 60minutes each along X, Y and Z axes				
	IMPACT	196.1m/s ² (20G), 11ms, once each X, Y and Z axes				
SAFETY AND NOISE REGULATIONS	AGENCY APPROVALS	ANSI/AAMI ES60601-1, EN60601-1 3rd				
	CONDUCTED NOISE	Complies with FCC-A, VCCI-A, CISPR32-A, EN55011-A, EN55032-A				
	HARMONIC ATTENUATOR *5	Complies with IEC61000-3-2 class A				

SPECIFICATIONS

OTHERS	CASE SIZE/WEIGHT	150×61×240mm [5.91×2.40×9.45 inches] (Excluding terminal block and screw) (W×H×D) / 2.8kg max
	COOLING METHOD	*6 Forced cooling (internal fan)
WARRANTY	WARRANTY	*7 5 years (subject to the operating conditions)

- *1 This is the result of measurement of the testing board with capacitors of 22 μ F and 0.1 μ F placed at 150 mm from the output terminals by a 20 MHz oscilloscope or a ripple-noise meter equivalent to Keisoku-Giken RM104.
See 1.6 of Instruction Manual for more details.
- *2 Consult us about dynamic load and input response.
- *3 Drift is the change in DC output for an eight hour period after a half-hour warm-up at 25°C.
- *4 Output power derating is required. Refer to "Derating".
- *5 Consult us about other classes.
- *6 The fan speed slows down or stops at no load.
- *7 See 3 in Instruction Manual for more details.
- *8 Consult us about safety agency approvals for the models with optional functions.
- * Do not use the power supply in overcurrent conditions or in unspecified input voltage ranges. Otherwise the internal components may be damaged.
- * Parallel operation is not possible with this mode.
- * Audible noise may be heard from the power supply when used for pulse load.

Features

- 4kV isolation
- Economical design
- Suitable for BF application (Output-FG : 1MOPP, Input-Output : 2MOPP)
- Wide temperature range (-20°C to +70°C, Refer to "Derating")
- Harmonic attenuator (Complies with IEC61000-3-2 class A)
- Universal input (AC85 - 264V, Refer to "Derating")
- Low power consumption at no load

Block diagram

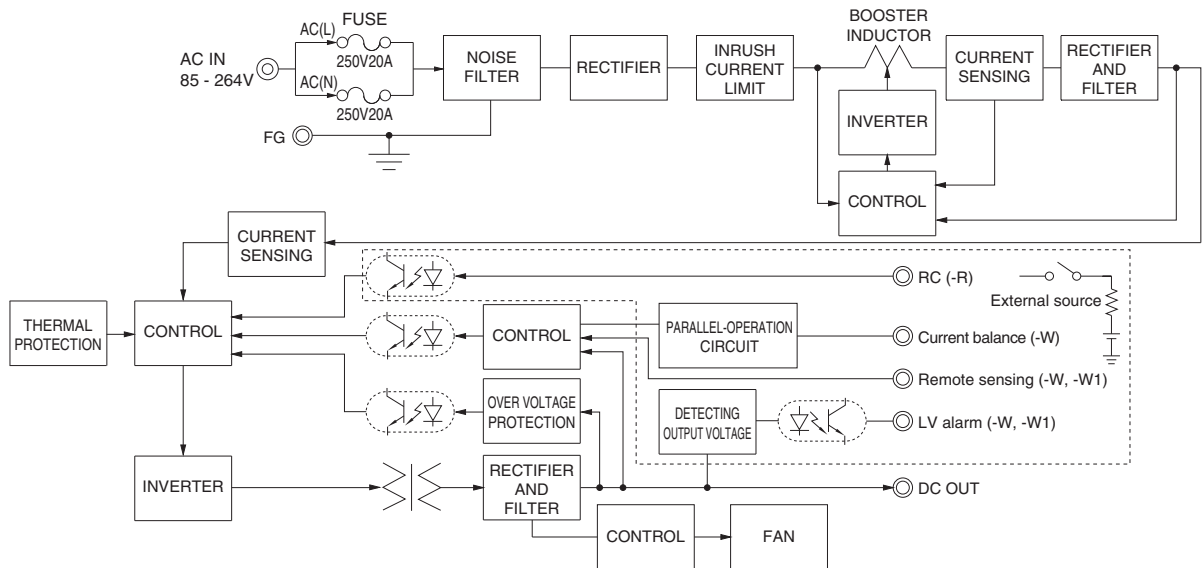

External view

The external size of -V option, -W option, -W1 option and -R option models is different from the standard model. See "5. Options and Others" in Instruction Manual for more details.

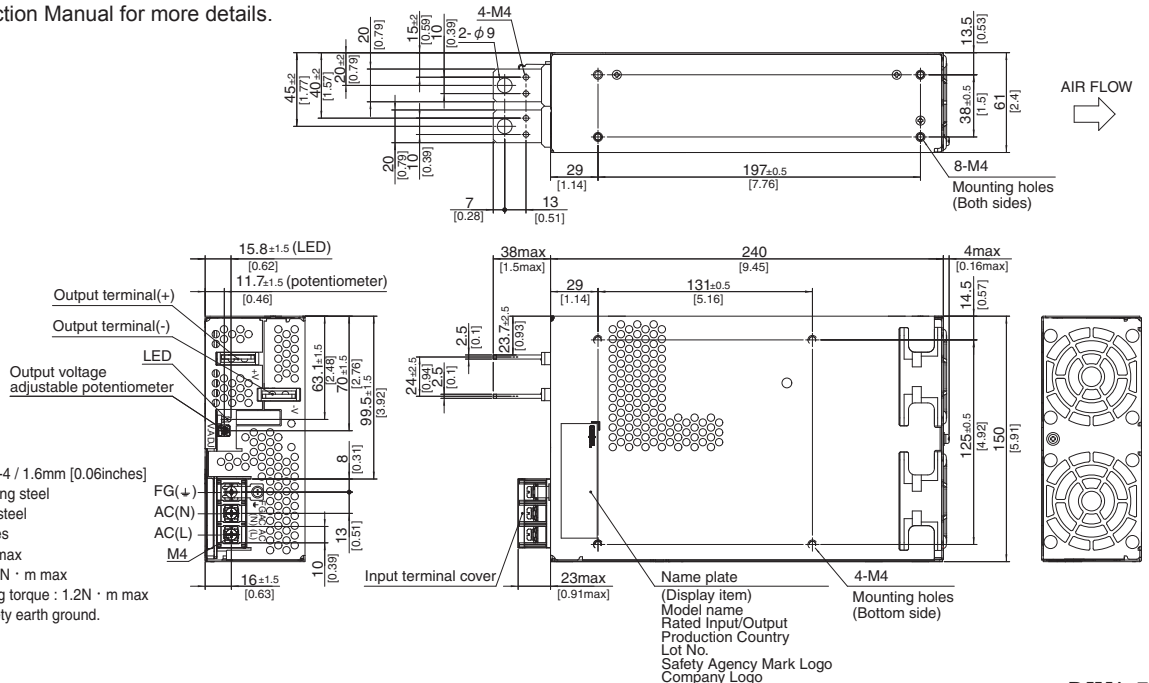

- ※Tolerance : ± 1 [± 0.04]
- ※Weight : 2.8kg max
- ※PCB Material/thickness : FR-4 / 1.6mm [0.06inches]
- ※Chassis material : Galvanizing steel
- ※Case material : Galvanizing steel
- ※Dimensions in mm, []=inches
- ※Mounting torque : 1.5N · m max
- ※Screw tightening torque : 1.6N · m max
- ※Output terminal M4 tightening torque : 1.2N · m max
- ※Connect the input FG to safety earth ground.

PJMA1500F

① **PJM** ② **A** ③ **1500** ④ **F** ⑤ **-□** ⑥ **-□**

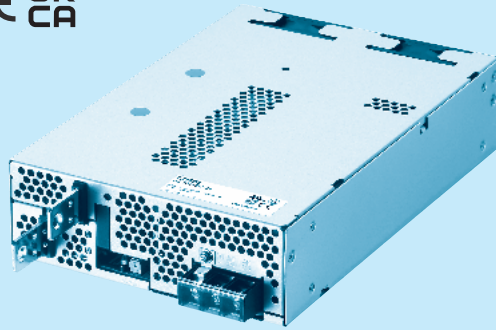
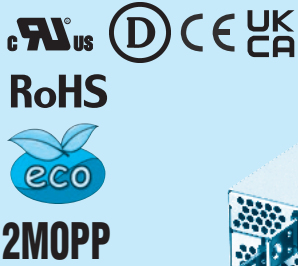

Example recommended EM/EMC filter
NAC-20-472



High voltage pulse noise type : NAP series
Low leakage current type : NAM series

- ① Series name
- ② Single output
- ③ Output wattage
- ④ Universal input
- ⑤ Output voltage
- ⑥ Optional *8
- C : with Coating
- G : Low leakage current
- V : External potentiometer for output voltage adjustment
- W : Parallel operation, LV alarm and Remote sensing (Except 48V)
- W1: LV alarm and Remote sensing
- R : Remote on/off (Required external power source)
- F4: Low speed fan

See 5.1 in Instruction Manual.

*Make sure necessary tests will be carried out on your end equipment with the power supply installed in accordance with any required EMC/EMI regulations.

SPECIFICATIONS

	MODEL	PJMA1500F-12	PJMA1500F-24	PJMA1500F-36	PJMA1500F-48	
INPUT	VOLTAGE[V]	AC85 - 264 1 φ (Output derating is required at AC85V - 115V. Refer to "Derating" and instruction manual 1.1)				
	CURRENT[A]	ACIN 100V	18typ (Io=90%)			
		ACIN 115V	16typ (Io=100%)			
		ACIN 230V	8typ (Io=100%)			
	FREQUENCY[Hz]	50 / 60 (47 - 63)				
	EFFICIENCY[%]	ACIN 100V	81typ (Io=90%)	84typ (Io=90%)	84typ (Io=90%)	84typ (Io=90%)
		ACIN 115V	82typ (Io=100%)	85typ (Io=100%)	85typ (Io=100%)	84typ (Io=100%)
ACIN 230V		85typ (Io=100%)	88typ (Io=100%)	88typ (Io=100%)	87typ (Io=100%)	
POWER FACTOR	ACIN 100V	0.98typ (Io=90%)				
	ACIN 115V	0.98typ (Io=100%)				
	ACIN 230V	0.95typ (Io=100%)				
INRUSH CURRENT[A]	ACIN 100V	15/30typ (Io=90%) (Primary inrush current /Secondary inrush current) (More than 10sec to re-start)				
	ACIN 115V	15/30typ (Io=100%) (Primary inrush current /Secondary inrush current) (More than 10sec to re-start)				
	ACIN 230V	30/30typ (Io=100%) (Primary inrush current /Secondary inrush current) (More than 10sec to re-start)				
LEAKAGE CURRENT[ma]	0.3max (ACIN 240V, 60Hz, Io=100%)					
OUTPUT	VOLTAGE[V]	12	24	36	48	
	CURRENT[A]	ACIN 85-115V	Output derating is required at ACIN 115V or less (Refer to "Derating")			
		ACIN 115V-264V	125	64	42	32
	WATTAGE[W]	ACIN 85-115V	Output derating is required at ACIN 115V or less (Refer to "Derating")			
		ACIN 115V-264V	1500	1536	1512	1536
	LINE REGULATION[mV]	*2	48max	96max	144max	192max
	LOAD REGULATION[mV]	*2	100max	150max	150max	300max
	RIPPLE[mVp-p]	0 to +50°C	180max	120max	150max	200max
		*1 -20 to 0°C	240max	160max	200max	500max
	RIPPLE NOISE[mVp-p]	0 to +50°C	210max	150max	200max	300max
		*1 -20 to 0°C	270max	270max	240max	600max
	TEMPERATURE REGULATION[mV]	0 to +50°C	120max	240max	360max	480max
		-20 to +50°C	180max	290max	440max	600max
DRIFT[mV]	*3	48max	96max	144max	192max	
START-UP TIME[ms]	800typ (ACIN 115V, Io=100%)					
HOLD-UP TIME[ms]	20typ (ACIN 115V, Io=100%)					
OUTPUT VOLTAGE ADJUSTMENT RANGE[V]	10.80 to 13.50	20.40 to 28.50	30.60 to 40.80	40.80 to 55.20		
OUTPUT VOLTAGE SETTING[V]	12.00 to 12.48	24.00 to 24.96	36.00 to 37.44	48.00 to 49.92		
PROTECTION CIRCUIT AND OTHERS	OVERCURRENT PROTECTION	Works over 105% of rating and recovers automatically				
	OVERVOLTAGE PROTECTION[V]	14.40 to 17.40	28.80 to 34.80	43.20 to 52.20	57.00 to 67.20	
	OPERATING INDICATION	LED (Green)				
	REMOTE SENSING	Optional (Option -W, -W1)				
	REMOTE ON/OFF	Optional (Required external power source. Option -R)				
ISOLATION	INPUT-OUTPUT	AC4,000V 1minute, Cutoff=20mA, 2MOPP DC500V 50MΩ min (At room temperature)				
	INPUT-FG	AC2,000V 1minute, Cutoff=20mA, 1MOPP DC500V 50MΩ min (At room temperature)				
	OUTPUT · RC-FG	*3	AC1,500V 1minute, Cutoff=20mA, 1MOPP DC500V 50MΩ min (At room temperature)			
	OUTPUT-RC	AC500V 1minute, Cutoff=20mA, DC500V 50MΩ min (At room temperature)				
ENVIRONMENT	OPERATING TEMP., HUMID. AND ALTITUDE *4	-20 to +70°C (Refer to "Derating"), 20 - 90%RH (Non condensing), 3,000m (10,000 feet) max				
	STORAGE TEMP., HUMID. AND ALTITUDE	-20 to +75°C, 20 - 90%RH (Non condensing), 9,000m (30,000 feet) max				
	VIBRATION	10 - 55Hz, 19.6m/s ² (2G), 3minutes period, 60minutes each along X, Y and Z axes				
	IMPACT	196.1m/s ² (20G), 11ms, once each X, Y and Z axes				
SAFETY AND NOISE REGULATIONS	AGENCY APPROVALS	ANSI/AAMI ES60601-1, EN60601-1 3rd				
	CONDUCTED NOISE	Complies with FCC-A, VCCI-A, CISPR32-A, EN55011-A, EN55032-A				
	HARMONIC ATTENUATOR *5	Complies with IEC61000-3-2 class A				

SPECIFICATIONS

OTHERS	CASE SIZE/WEIGHT	178×61×268mm [7.01×2.40×10.55 inches] (Excluding terminal block and screw) (W×H×D) / 3.5kg max
	COOLING METHOD	*6 Forced cooling (internal fan)
WARRANTY	WARRANTY	*7 5 years (subject to the operating conditions)

- *1 This is the result of measurement of the testing board with capacitors of 22 μ F and 0.1 μ F placed at 150 mm from the output terminals by a 20 MHz oscilloscope or a ripple-noise meter equivalent to Keisoku-Giken RM103.
See 1.6 of Instruction Manual for more details.
- *2 Consult us about dynamic load and input response.
- *3 Drift is the change in DC output for an eight hour period after a half-hour warm-up at 25°C.
- *4 Output power derating is required. Refer to "Derating".
- *5 Consult us about other classes.
- *6 The fan speed slows down or stops at no load.
- *7 See 3 in Instruction Manual for more details.
- *8 Consult us about safety agency approvals for the models with optional functions.
- * Do not use the power supply in overcurrent conditions or in unspecified input voltage ranges. Otherwise the internal components may be damaged.
- * Parallel operation is not possible with this mode.
- * Audible noise may be heard from the power supply when used for pulse load.

Features

- 4kV isolation
- Economical design
- Suitable for BF application (Output-FG : 1MOPP, Input-Output : 2MOPP)
- Wide temperature range (-20°C to +70°C, Refer to "Derating")
- Harmonic attenuator (Complies with IEC61000-3-2 class A)
- Universal input (AC85 - 264V, Refer to "Derating")
- Low power consumption at no load

Block diagram

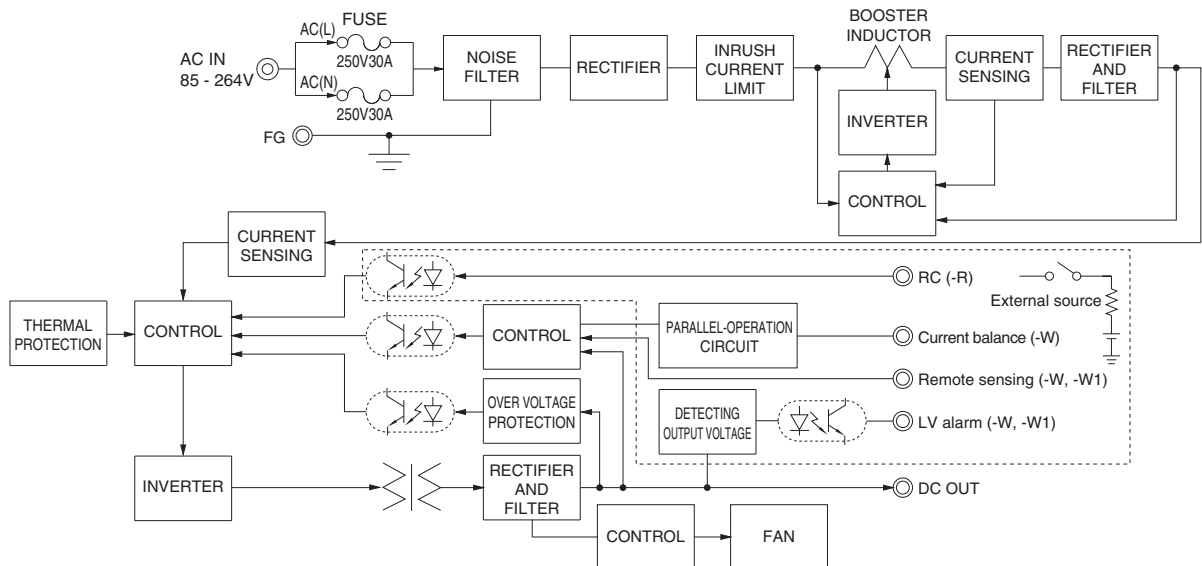

External view

The external size of -R option, -W option, -W1 option and -R option models is different from the standard model. See "5. Options and Others" in Instruction Manual for more details.

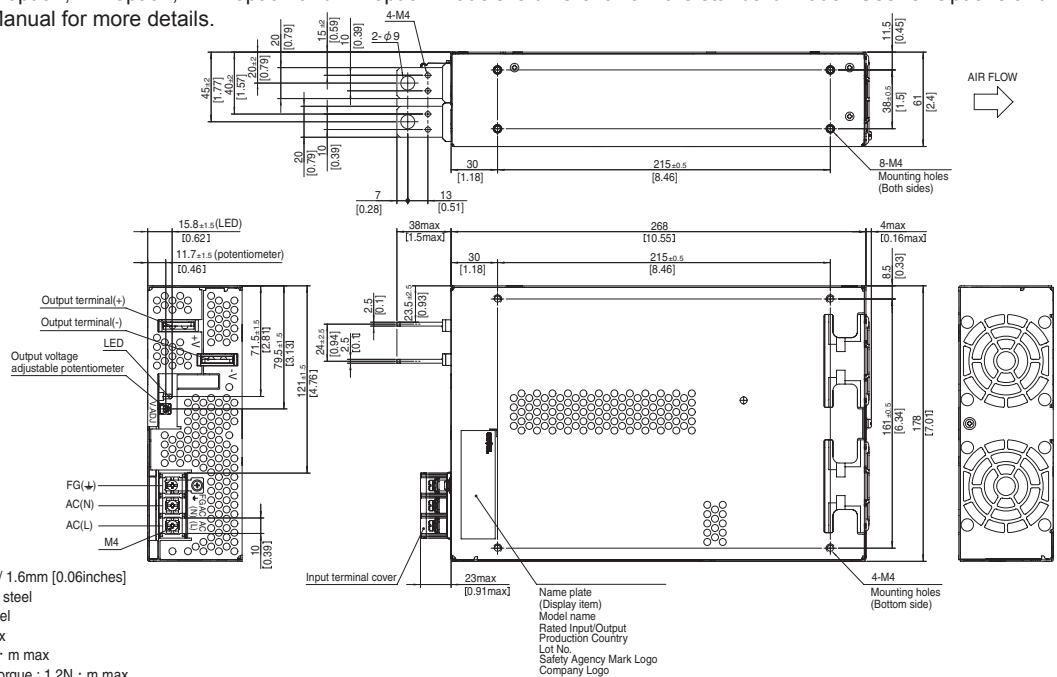

Assembling and Installation Method

- Do not insert a screw more than 6mm from the outside of a power supply to keep enough insulation distance between the screw and internal components.

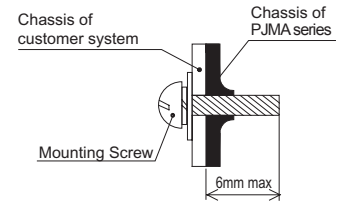

PJMA300F

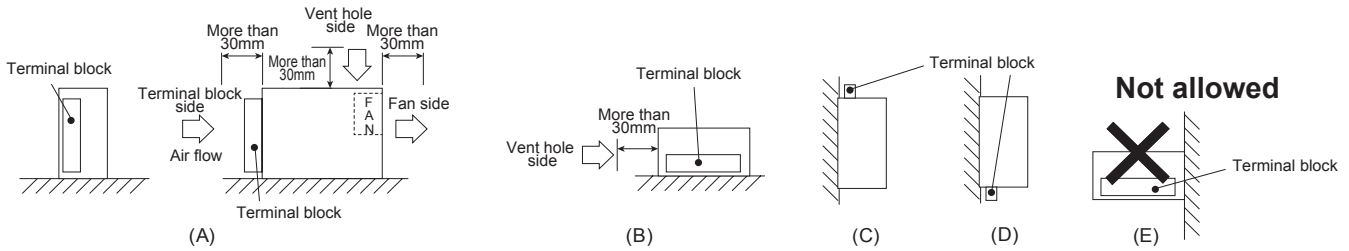

PJMA600F

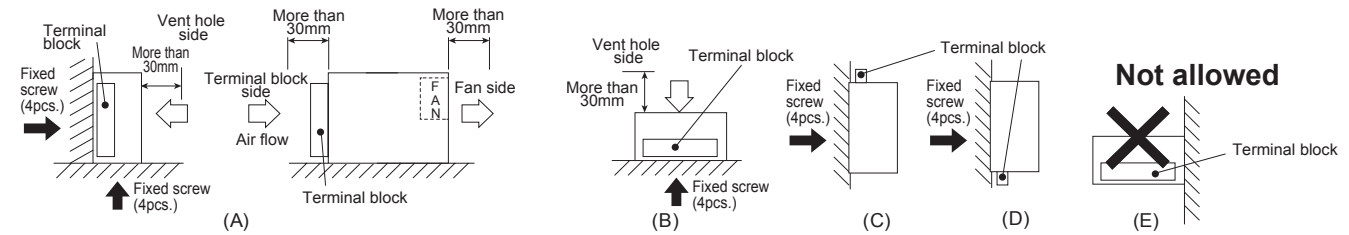

PJMA1000F, PJMA1500F

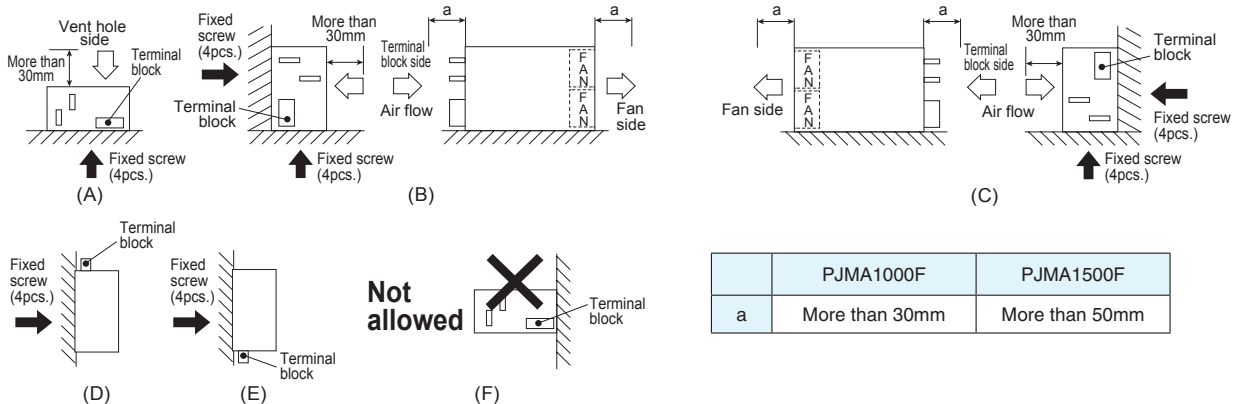

Assembling and Installation Method

- When mounting the power supply with screws, it is recommended that this be done as shown above. If other methods are used, be sure the weight of the power supply is taken into account.
- Avoid the not allowed installation method as it gives excessive stress to the mounting holes.
- Do not block air flow of the built-in fan (terminal block and ventilation hole).
- If the power supply is used in a dusty environment, use an airfilter. Make sure air flow is not blocked.
- If the built-in fan stops, thermal protection will work and the output will stop.
- The life expectancy (R(t)=90%) of the built-in fan varies depending on the operating condition.

Derating

● Input voltage Derating Curve

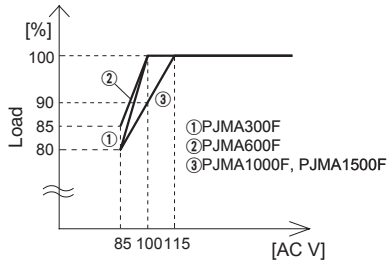

● Ambient temperature Derating Curve

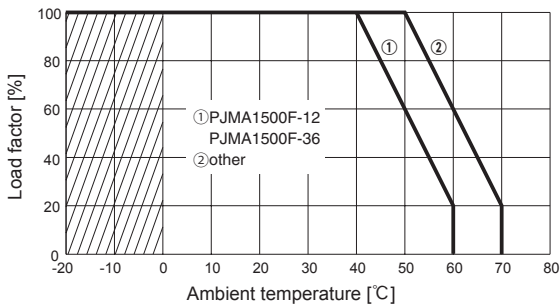

- In the hatched area, the specification of Ripple, Ripple Noise is different from other area.
- The ambient temperature is defined as the temperature of the air (at the terminal block side) that the built-in cooling fan blows into the power supply. Please pay attention to the heat generated by the input and output wires. Please consult us for more details.

Instruction Manual

- ◆ It is necessary to read the “Instruction Manual” and “Before using our product” before you use our product.

Instruction Manual <https://en.cosel.co.jp/product/powersupply/PJMA/>
 Before using our product <https://en.cosel.co.jp/technical/caution/index.html>

PJMA



NOTICE



Basic Characteristics Data

Model	Circuit method	Switching frequency [kHz]	Input current [A]	Rated input fuse	Inrush current protection circuit	PCB/Pattern			Series/Parallel operation availability	
						Material	Single sided	Double sided	Series operation	Parallel operation
PJMA300F	Active filter	60	3.9 *1	250V 10A	Thermistor	FR-4		Yes	Yes	No
	Forward converter	140						Yes	Yes	No
PJMA600F	Active filter	60	7.5 *1	250V 16A	SCR	FR-4		Yes	Yes	No
	Forward converter	220						Yes	Yes	No
PJMA1000F	Active filter	65	12.5 *2	250V 20A	TRIAC	FR-4		Yes	Yes	*3
	Forward converter	210						Yes	Yes	*3
PJMA1500F	Active filter	65	18.0 *1	250V 30A	TRIAC	FR-4		Yes	Yes	*4
	Forward converter	210						Yes	Yes	*4

*1 The input current shown is at ACIN 100V and 100% load.
 *2 The input current shown is at ACIN 100V and 90% load.
 *3 Parallel operation is possible with -W option. see “5.Option and Other” is Instruction Manual.
 *4 Parallel operation is possible with -W option. (Except 48V) see “5.Option and Other” is Instruction Manual.

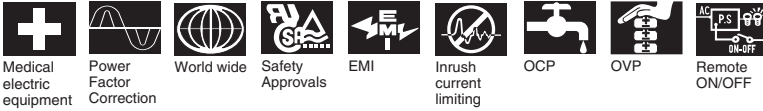

PMA-series

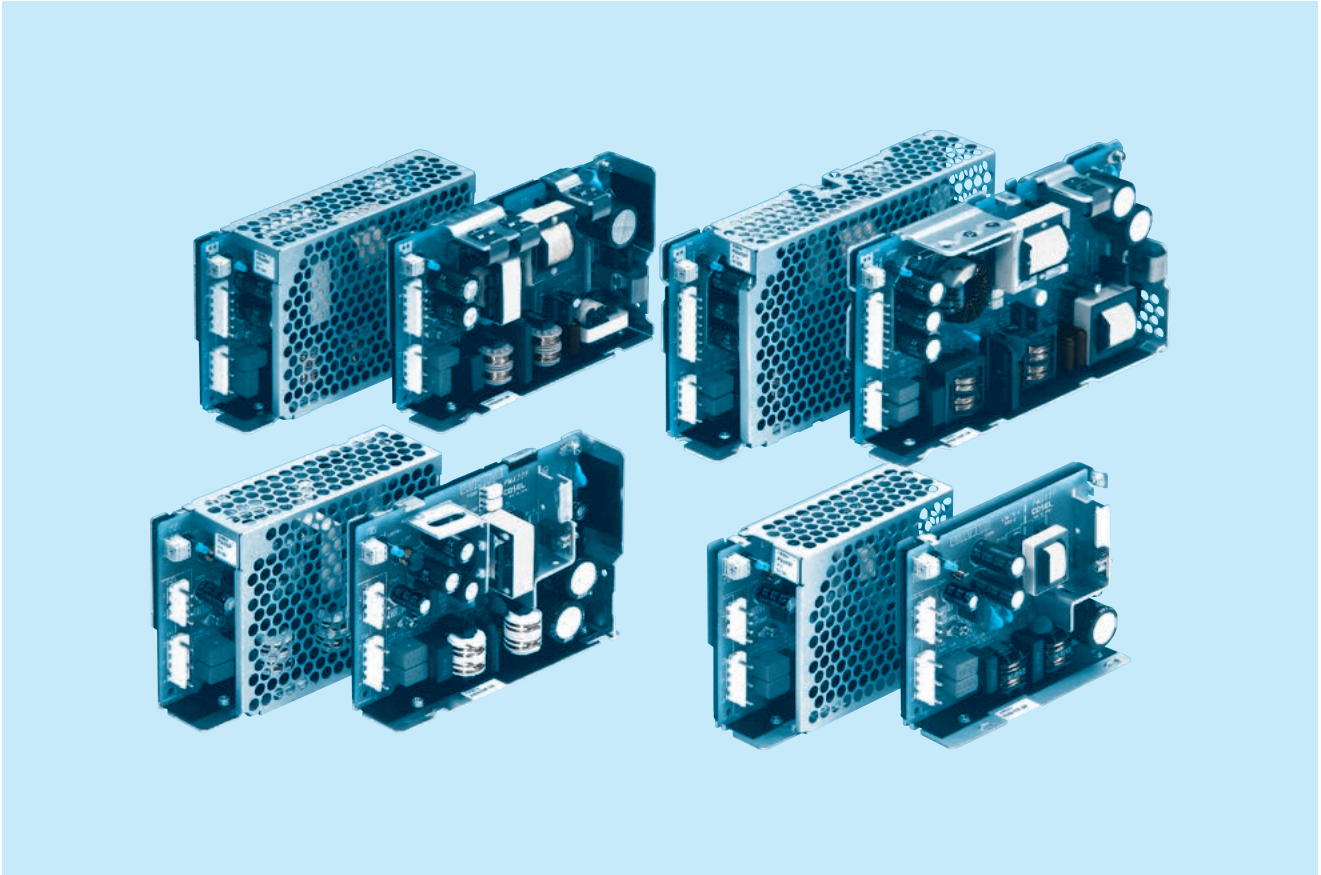

Feature

- For medical electric equipment
- Internal dual fuses
- Harmonic attenuator (Complies with IEC61000-3-2)
- Universal input (AC85 - 264V)
- Efficiency increased with synchronous rectification technology (PMA60F, PMA100F)
- Variety of option

Safety agency approvals

UL60601-1, C-UL (CSA-C22.2 No.601.1), EN60601-1

EMI

FCC-B, CISPR11-B, CISPR22-B, EN55011-B, EN55022-B, VCCI-B

5-year warranty (refer to Instruction Manual)

CE marking

Low Voltage Directive
RoHS Directive

UKCA marking

Electrical Equipment Safety Regulations
RoHS Regulations

EMS Compliance : EN61204-3, EN61000-6-2

EN61000-4-2
EN61000-4-3
EN61000-4-4
EN61000-4-5 (Common mode Level4, Differential mode Level2)
EN61000-4-6
EN61000-4-8
EN61000-4-11

PMA15F

① PM ② A ③ 15 ④ F ⑤ -□ ⑥ -□

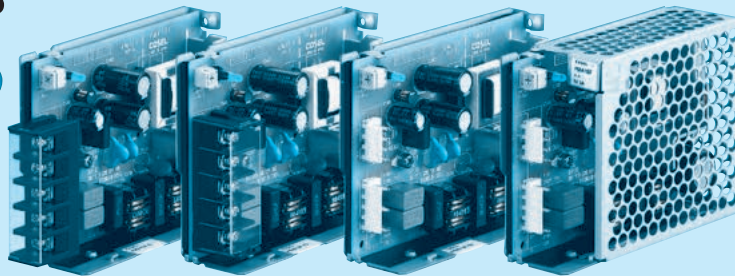

Horizontal terminal block (option : -T1) Vertical terminal block (option : -T) Standard type with Cover (option : -N)

Example recommended EMI/EMC filter
NAM-04-000



Low leakage current type : NAM series
* A higher current rating EMI/EMC filter may be recommended in view of the other devices that could be connected in parallel with the power supply.

- ① Series name
- ② Single output
- ③ Output wattage
- ④ Universal input
- ⑤ Output voltage
- ⑥ Optional *5
- T : Vertical terminal block
- T1 : Horizontal terminal block
- N : with Cover
- J1 : VH(J.S.T.)connector type

Specification is changed at option, refer to Instruction Manual.

*Make sure necessary tests will be carried out on your end equipment with the power supply installed in accordance with any required EMC/EMI regulations.

MODEL	PMA15F-3R3	PMA15F-5	PMA15F-12	PMA15F-15	PMA15F-24
MAX OUTPUT WATTAGE[W]	9.9	15	15.6	15	16.8
DC OUTPUT	3.3V 3A	5V 3A	12V 1.3A	15V 1A	24V 0.7A

SPECIFICATIONS

	MODEL	PMA15F-3R3	PMA15F-5	PMA15F-12	PMA15F-15	PMA15F-24	
INPUT	VOLTAGE[V]	AC85 - 264 1 φ (Refer to the Instruction Manual 1.1 and "Derating") *3					
	CURRENT[A]	ACIN 100V	0.30typ (Io=100%)	0.40typ (Io=100%)			
		ACIN 200V	0.15typ (Io=100%)	0.20typ (Io=100%)			
	FREQUENCY[Hz]	50 / 60 (47 - 440)					
	EFFICIENCY[%]	ACIN 100V	66typ	70typ	74typ	76typ	76typ
		ACIN 200V	67typ	74typ	78typ	79typ	79typ
INRUSH CURRENT[A]	ACIN 100V	15typ (Io=100%) (At cold start)					
	ACIN 200V	30typ (Io=100%) (At cold start)					
LEAKAGE CURRENT[mA]	0.05/0.10max (ACIN 100V / 240V 60Hz, Io=100%, According to IEC60601-1)						
OUTPUT	VOLTAGE[V]	3.3	5	12	15	24	
	CURRENT[A]	3.0	3.0	1.3	1.0	0.7	
	LINE REGULATION[mV]	20max	20max	48max	60max	96max	
	LOAD REGULATION[mV]	40max	40max	100max	120max	150max	
	RIPPLE[mVp-p]	0 to +50°C	80max	80max	120max	120max	120max
		-10 - 0°C	140max	140max	160max	160max	160max
	RIPPLE NOISE[mVp-p]	0 to +50°C	120max	120max	150max	150max	150max
		-10 - 0°C	160max	160max	180max	180max	180max
	TEMPERATURE REGULATION[mV]	0 to +50°C	50max	50max	120max	150max	240max
		-10 to +50°C	60max	60max	150max	180max	290max
	DRIFT[mV]	*2	20max	20max	48max	60max	96max
START-UP TIME[ms]	200typ (ACIN 100V, Io=100%) *Start-up time is 700ms typ for less than 1minute of applying input again from turning off the input voltage.						
HOLD-UP TIME[ms]	20typ (ACIN 100V, Io=100%)						
OUTPUT VOLTAGE ADJUSTMENT RANGE[V]	2.85 to 3.60		4.50 to 5.50		10.00 to 13.20		
OUTPUT VOLTAGE SETTING[V]	3.30 to 3.40		5.00 to 5.15		12.00 to 12.48		
PROTECTION CIRCUIT AND OTHERS	OVERCURRENT PROTECTION	Works over 105% of rating and recovers automatically					
	OVERVOLTAGE PROTECTION[V]	4.00 to 5.25	5.75 to 7.00	15.00 to 18.00	20.00 to 25.00	30.00 to 37.00	
	OPERATING INDICATION	LED (Green)					
	REMOTE ON/OFF	Not provided					
ISOLATION	INPUT-OUTPUT	AC4,000V 1minute, Cutoff current = 10mA, DC500V 50MΩ min (At Room Temperature)					
	INPUT-FG	AC2,000V 1minute, Cutoff current = 10mA, DC500V 50MΩ min (At Room Temperature)					
	OUTPUT-FG	AC500V 1minute, Cutoff current = 25mA, DC500V 50MΩ min (At Room Temperature)					
ENVIRONMENT	OPERATING TEMP., HUMID. AND ALTITUDE	-10 to +70°C, 20 - 90%RH (Non condensing), 3,000m (10,000 feet) max *3					
	STORAGE TEMP., HUMID. AND ALTITUDE	-20 to +75°C, 20 - 90%RH (Non condensing), 9,000m (30,000 feet) max					
	VIBRATION	10 - 55Hz, 19.6m/s ² (2G), 3minutes period, 60minutes each along X, Y and Z axis					
	IMPACT	196.1m/s ² (20G), 11ms, once each X, Y and Z axis					
SAFETY AND NOISE REGULATIONS	AGENCY APPROVALS	UL60601-1, C-UL (CSA-C22.2 No.601.1), EN60601-1					
	CONDUCTED NOISE	Complies with FCC-B, VCCI-B, CISPR11-B, CISPR22-B, EN55011-B, EN55022-B					
	HARMONIC ATTENUATOR	Complies with IEC61000-3-2 (Class A) *6 (Not built-in to active filter *4)					
OTHERS	CASE SIZE/WEIGHT	31 X 78 X 103mm [1.22 X 3.07 X 4.06 inches] (W X H X D) / 230g max (with cover : 265g max)					
	COOLING METHOD	Convection					

*1 Measured by 20MHz oscilloscope or Ripple-Noise meter (equivalent to KEISOKU-GIKEN: RM101).
*2 Drift is the change in DC output for an eight hour period after a half-hour warm-up at 25°C.
*3 Refer to "Derating".
*4 When two or more units are used, they may not comply with the harmonic attenuator. Please contact us for details.

*5 Please contact us about safety approvals for the model with option.
*6 Please contact us about another class.
* Parallel operation with other model is not possible.
* Derating is required when operated with cover.
* A sound may occur from power supply at peak loading.

Block diagram

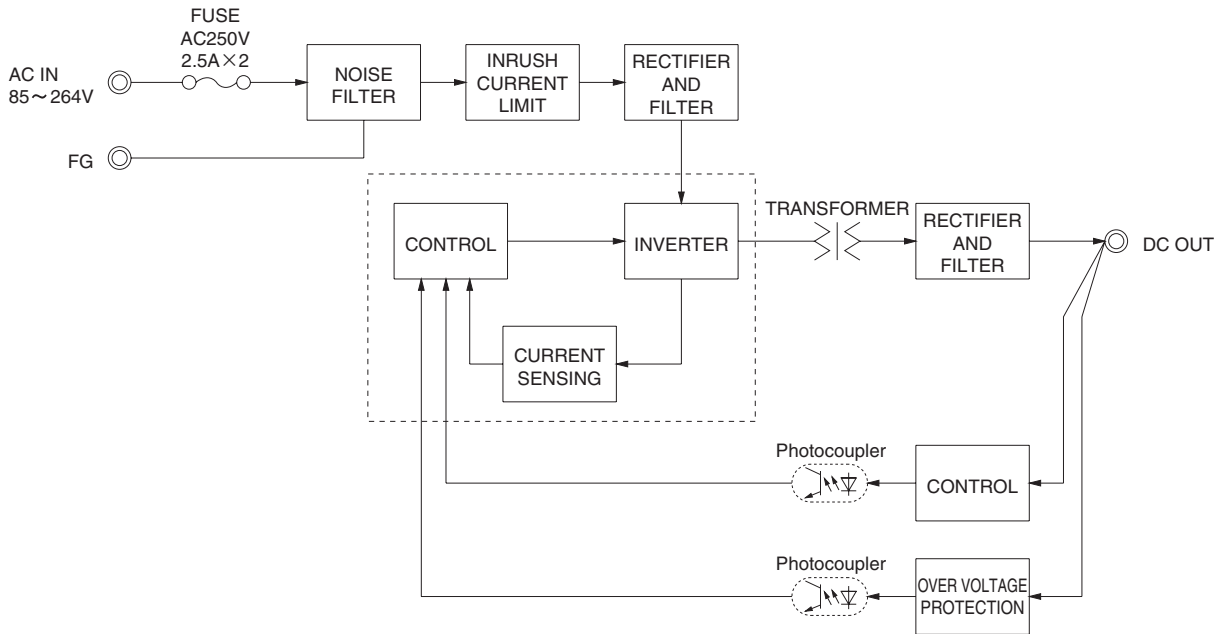

External view

※ External size of option T and T1 is different from standard model and refer to 5 Option of instruction manual for details.

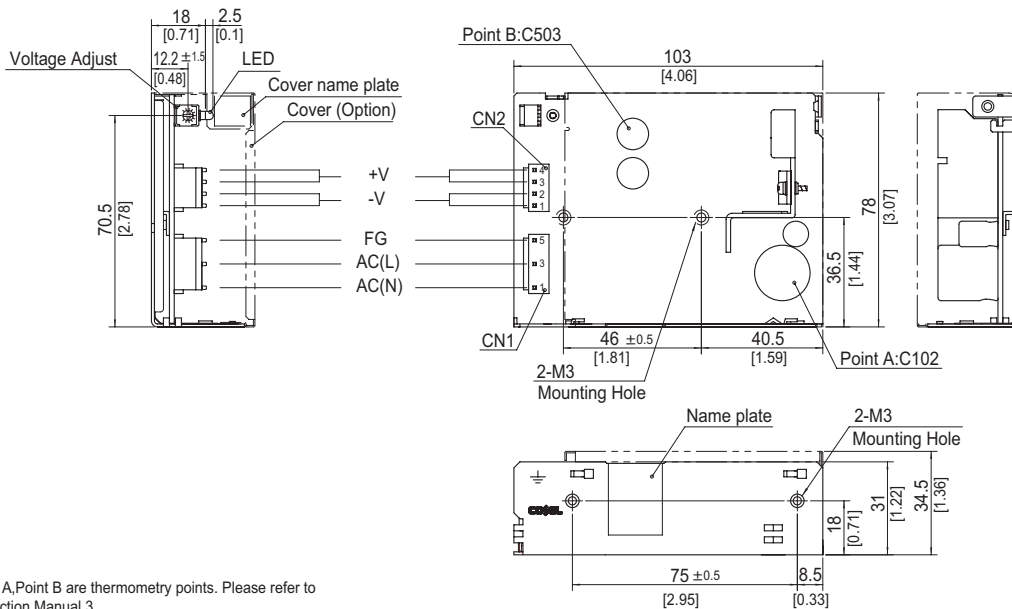

※ Point A, Point B are thermometry points. Please refer to Instruction Manual 3.

I/O Connector	Mating Connector	Terminal
CN1	1-1123724-3	Chain 1123721-1
		Loose 1318912-1
CN2	1-1123723-4	Chain 1123721-1
		Loose 1318912-1

(Mfr : Tyco Electronics AMP)

※ I/O Connector is Mfr. Tyco Electronics AMP
 ※ Option : -J1 : (J.S.T) connector type
 -T : Vertical terminal block type
 -T1 : Horizontal terminal block type
 Refer to Instruction Manual 5.

<PIN CONNECTION>

Pin No.	Input	Pin No.	Output
1	AC(N)	1, 2	-V
2		3, 4	+V
3	AC(L)		
4			
5	FG		

※ Tolerance : ±1 [±0.04]
 ※ Weight : 230g max (with cover : 265g max)
 ※ PCB Material/thickness : CEM-3 / 1.6mm [0.06inches]
 ※ Chassis material : Hot-dip galvanized steel plate
 ※ Keep drawing current per pin below 5A of CN2.
 ※ Dimensions in mm, []=inches
 ※ Mounting torque : 0.6N · m (6.3kgf · cm) max
 ※ Please connect safety ground to the unit in 2-M3 holes.

PMA30F

① PM ② A ③ 30 ④ F ⑤ -□ ⑥ -□



RoHS

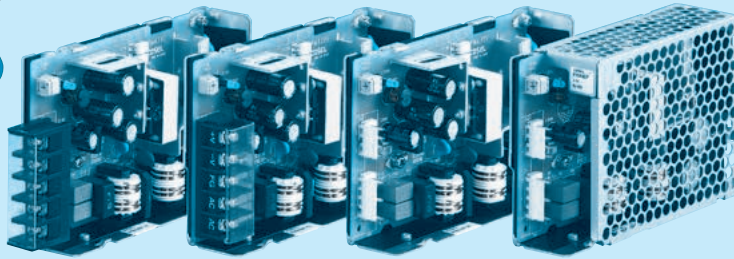

Horizontal terminal block (option : -T1) Vertical terminal block (option : -T) Standard type with Cover (option : -N)

Example recommended EMI/EMC filter
NAM-04-000



Low leakage current type : NAM series
* A higher current rating EMI/EMC filter may be recommended in view of the other devices that could be connected in parallel with the power supply.

- ① Series name
- ② Single output
- ③ Output wattage
- ④ Universal input
- ⑤ Output voltage
- ⑥ Optional *5
- T : Vertical terminal block
- T1 : Horizontal terminal block
- N : with Cover
- J1 : VH(J.S.T.)connector type

Specification is changed at option, refer to Instruction Manual.

*Make sure necessary tests will be carried out on your end equipment with the power supply installed in accordance with any required EMC/EMI regulations.

MODEL	PMA30F-3R3	PMA30F-5	PMA30F-12	PMA30F-15	PMA30F-24
MAX OUTPUT WATTAGE[W]	19.8	30	30	30	31.2
DC OUTPUT	3.3V 6A	5V 6A	12V 2.5A	15V 2A	24V 1.3A

SPECIFICATIONS

	MODEL	PMA30F-3R3	PMA30F-5	PMA30F-12	PMA30F-15	PMA30F-24	
INPUT	VOLTAGE[V]	AC85 - 264 1 φ (Refer to the Instruction Manual 1.1 and "Derating") *3					
	CURRENT[A]	ACIN 100V	0.50typ (Io=100%)	0.70typ (Io=100%)			
		ACIN 200V	0.30typ (Io=100%)	0.40typ (Io=100%)			
	FREQUENCY[Hz]	50 / 60 (47 - 440)					
	EFFICIENCY[%]	ACIN 100V	67typ	71typ	76typ	77typ	
		ACIN 200V	69typ	74typ	78typ	80typ	
INRUSH CURRENT[A]	ACIN 100V	15typ (Io=100%) (At cold start)					
	ACIN 200V	30typ (Io=100%) (At cold start)					
LEAKAGE CURRENT[mA]	0.05 / 0.10max (ACIN 100V / 240V 60Hz, Io=100%, According to IEC60601-1)						
OUTPUT	VOLTAGE[V]	3.3	5	12	15	24	
	CURRENT[A]	6.0	6.0	2.5	2.0	1.3	
	LINE REGULATION[mV]	20max	20max	48max	60max	96max	
	LOAD REGULATION[mV]	40max	40max	100max	120max	150max	
	RIPPLE[mVp-p]	*1	0 to +50°C	80max	80max	120max	120max
			-10 - 0°C	140max	140max	160max	160max
	RIPPLE NOISE[mVp-p]	*1	0 to +50°C	120max	120max	150max	150max
			-10 - 0°C	160max	160max	180max	180max
	TEMPERATURE REGULATION[mV]	*1	0 to +50°C	50max	50max	120max	240max
			-10 to +50°C	60max	60max	150max	180max
DRIFT[mV]	*2	20max	20max	48max	60max	96max	
START-UP TIME[ms]	200typ (ACIN 100V, Io=100%) *Start-up time is 700ms typ for less than 1minute of applying input again from turning off the input voltage.						
HOLD-UP TIME[ms]	20typ (ACIN 100V, Io=100%)						
PROTECTION CIRCUIT AND OTHERS	OUTPUT VOLTAGE ADJUSTMENT RANGE[V]	2.85 to 3.60	4.50 to 5.50	10.00 to 13.20	13.20 to 18.00	19.20 to 27.00	
	OUTPUT VOLTAGE SETTING[V]	3.30 to 3.40	5.00 to 5.15	12.00 to 12.48	15.00 to 15.60	24.00 to 24.96	
	OVERCURRENT PROTECTION	Works over 105% of rating and recovers automatically					
	OVERVOLTAGE PROTECTION[V]	4.00 to 5.25	5.75 to 7.00	15.00 to 18.00	20.00 to 25.00	30.00 to 37.00	
ISOLATION	OPERATING INDICATION	LED (Green)					
	REMOTE ON/OFF	Not provided					
	INPUT-OUTPUT	AC4,000V 1minute, Cutoff current = 10mA, DC500V 50MΩ min (At Room Temperature)					
ENVIRONMENT	INPUT-FG	AC2,000V 1minute, Cutoff current = 10mA, DC500V 50MΩ min (At Room Temperature)					
	OUTPUT-FG	AC500V 1minute, Cutoff current = 25mA, DC500V 50MΩ min (At Room Temperature)					
	OPERATING TEMP., HUMID. AND ALTITUDE	-10 to +70°C, 20 - 90%RH (Non condensing), 3,000m (10,000feet) max *3					
SAFETY AND NOISE REGULATIONS	STORAGE TEMP., HUMID. AND ALTITUDE	-20 to +75°C, 20 - 90%RH (Non condensing), 9,000m (30,000feet) max					
	VIBRATION	10 - 55Hz, 19.6m/s ² (2G), 3minutes period, 60minutes each along X, Y and Z axis					
	IMPACT	196.1m/s ² (20G), 11ms, once each X, Y and Z axis					
OTHERS	AGENCY APPROVALS	UL60601-1, C-UL (CSA-C22.2 No.601.1), EN60601-1					
	CONDUCTED NOISE	Complies with FCC-B, VCCI-B, CISPR11-B, CISPR22-B, EN55011-B, EN55022-B					
	HARMONIC ATTENUATOR	Complies with IEC61000-3-2 (Class A) *6 (Not built-in to active filter *4)					
OTHERS	CASE SIZE/WEIGHT	31 X 82 X 120mm [1.22 X 3.23 X 4.72 inches] (W X H X D) / 240g max (with cover : 280g max)					
	COOLING METHOD	Convection					

*1 Measured by 20MHz oscilloscope or Ripple-Noise meter (equivalent to KEISOKU-GIKEN: RM101).
 *2 Drift is the change in DC output for an eight hour period after a half-hour warm-up at 25°C.
 *3 Refer to "Derating".
 *4 When two or more units are used, they may not comply with the harmonic attenuator. Please contact us for details.

*5 Please contact us about safety approvals for the model with option.
 *6 Please contact us about another class.
 * Parallel operation with other model is not possible.
 * Derating is required when operated with cover.
 * A sound may occur from power supply at peak loading.

Block diagram

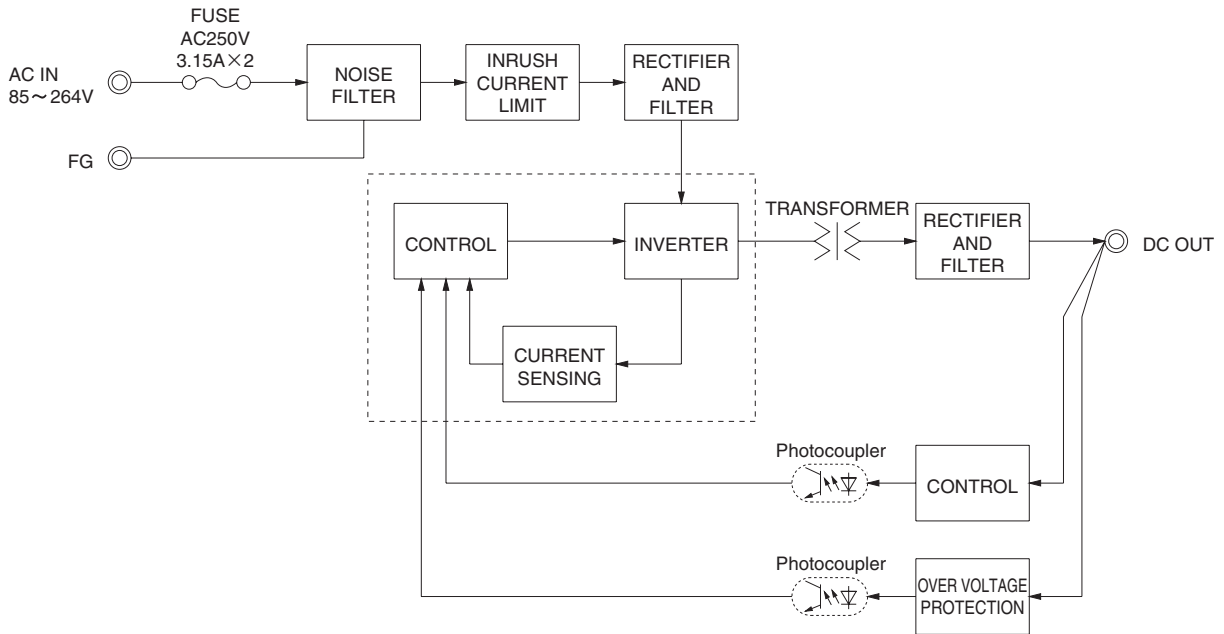

External view

※ External size of option T and T1 is different from standard model and refer to 5 Option of instruction manual for details.

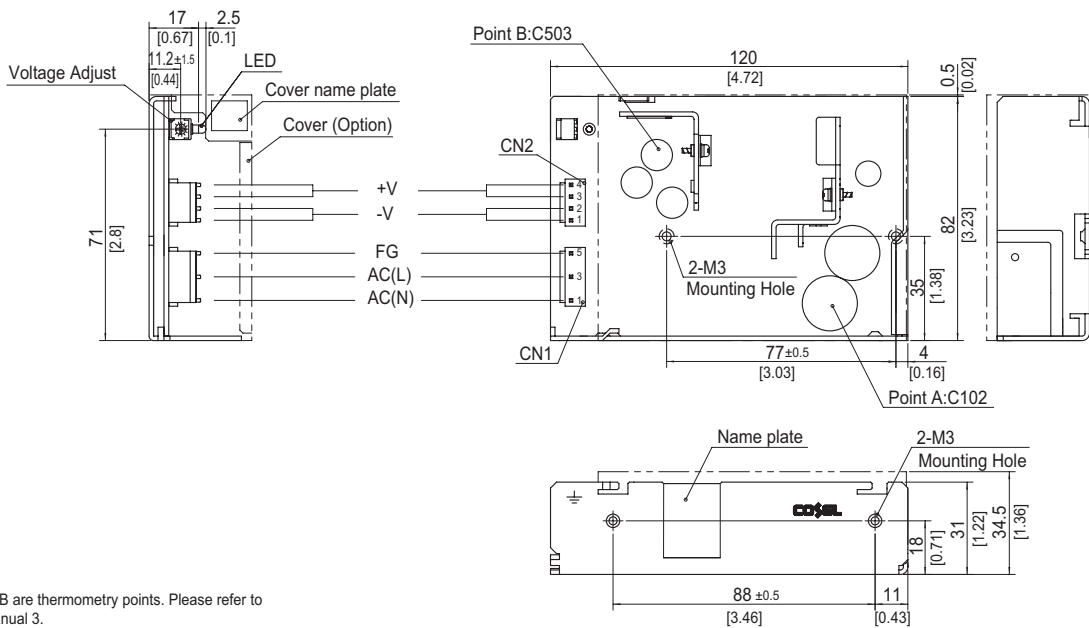

※ Point A, Point B are thermometry points. Please refer to Instruction Manual 3.

I/O Connector	Mating Connector	Terminal
CN1	1-1123724-3	Chain 1123721-1
		Loose 1318912-1
CN2	1-1123723-4	Chain 1123721-1
		Loose 1318912-1

(Mfr: Tyco Electronics AMP)

※ I/O Connector is Mfr. Tyco Electronics AMP
 ※ Option : -J1 : (J.S.T) connector type
 -T : Vertical terminal block type
 -T1 : Horizontal terminal block type
 Refer to Instruction Manual 5.

<PIN CONNECTION>

CN1		CN2	
Pin No.	Input	Pin No.	Output
1	AC(N)	1, 2	-V
2		3, 4	+V
3	AC(L)		
4			
5	FG		

※ Tolerance : ±1 [±0.04]
 ※ Weight : 240g max (with cover : 280g max)
 ※ PCB Material/thickness : CEM-3 / 1.6mm [0.06inches]
 ※ Chassis material : Aluminum
 ※ Keep drawing current per pin below 5A of CN2.
 ※ Dimensions in mm, []=inches
 ※ Mounting torque : 0.49N · m (5kgf · cm) max
 ※ Please connect safety ground to the unit in 2-M3 holes.

PMA60F

① PM ② A ③ 60 ④ F ⑤ -□ ⑥ -□

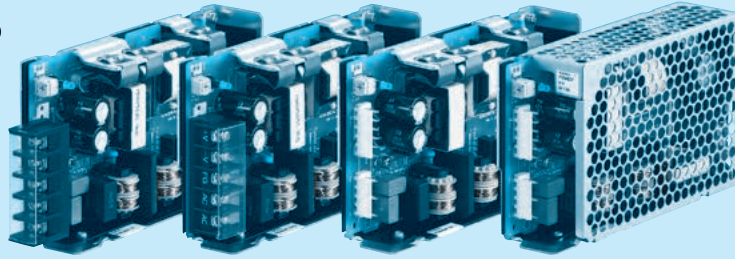
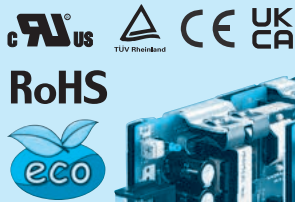

Horizontal terminal block (option : -T1) Vertical terminal block (option : -T) Standard type with Cover (option : -N)

Example recommended EMI/EMC filter
NAM-04-000



Low leakage current type : NAM series
* A higher current rating EMI/EMC filter may be recommended in view of the other devices that could be connected in parallel with the power supply.

- ① Series name
- ② Single output
- ③ Output wattage
- ④ Universal input
- ⑤ Output voltage
- ⑥ Optional *5
- T : Vertical terminal block
- T1 : Horizontal terminal block
- N : with Cover
- J1 : VH(J.S.T.)connector type
- R : with Remote ON/OFF

Specification is changed at option, refer to Instruction Manual.

*Make sure necessary tests will be carried out on your end equipment with the power supply installed in accordance with any required EMC/EMI regulations.

MODEL	PMA60F-3R3	PMA60F-5	PMA60F-12	PMA60F-15	PMA60F-24
MAX OUTPUT WATTAGE[W]	39.6	60	60	60	60
DC OUTPUT	3.3V 12A	5V 12A	12V 5A	15V 4A	24V 2.5A

SPECIFICATIONS

	MODEL	PMA60F-3R3	PMA60F-5	PMA60F-12	PMA60F-15	PMA60F-24	
INPUT	VOLTAGE[V]	AC85 - 264 1 φ (Refer to the Instruction Manual 1.1)					
	CURRENT[A]	ACIN 100V	0.7typ (Io=100%)	0.8typ (Io=100%)			
		ACIN 200V	0.4typ (Io=100%)	0.5typ (Io=100%)			
	FREQUENCY[Hz]	50 / 60 (47 - 63)					
	EFFICIENCY[%]	ACIN 100V	77typ	80typ	80typ	81typ	81typ
		ACIN 200V	78typ	83typ	82typ	83typ	83typ
	POWER FACTOR (Io=100%)	ACIN 100V	0.98typ				
		ACIN 200V	0.85typ		0.90typ		
INRUSH CURRENT[A]	ACIN 100V	15typ (Io=100%) (At cold start)					
	ACIN 200V	30typ (Io=100%) (At cold start)					
LEAKAGE CURRENT[ma]	0.09 / 0.18max (ACIN 100V / 240V 60Hz, Io=100%, According to IEC60601-1)						
OUTPUT	VOLTAGE[V]	3.3	5	12	15	24	
	CURRENT[A]	12.0	12.0	5.0	4.0	2.5	
	LINE REGULATION[mV]	20max	20max	48max	60max	96max	
	LOAD REGULATION[mV]	40max	40max	100max	120max	150max	
	RIPPLE[mVp-p] *1	0 to +50°C	80max	80max	120max	120max	120max
		-10 - 0°C	140max	140max	160max	160max	160max
	RIPPLE NOISE[mVp-p] *1	0 to +50°C	120max	120max	150max	150max	150max
		-10 - 0°C	160max	160max	180max	180max	180max
	TEMPERATURE REGULATION[mV]	0 to +50°C	50max	50max	120max	150max	240max
		-10 to +50°C	60max	60max	150max	180max	290max
	DRIFT[mV] *2	20max	20max	48max	60max	96max	
START-UP TIME[ms]	250typ (ACIN 100V, Io=100%)						
HOLD-UP TIME[ms]	20typ (ACIN 100V, Io=100%)						
OUTPUT VOLTAGE ADJUSTMENT RANGE[V]	2.85 to 3.60	4.50 to 5.50	10.00 to 13.20	13.20 to 18.00	19.20 to 27.00		
OUTPUT VOLTAGE SETTING[V]	3.30 to 3.40	5.00 to 5.15	12.00 to 12.48	15.00 to 15.60	24.00 to 24.96		
PROTECTION CIRCUIT AND OTHERS	OVERCURRENT PROTECTION	Works over 105% of rating and recovers automatically					
	OVERVOLTAGE PROTECTION[V]	4.00 to 5.25	5.75 to 7.00	15.00 to 18.00	20.00 to 25.00	30.00 to 37.00	
	OPERATING INDICATION	LED (Green)					
	REMOTE ON/OFF	Optional (Required external power source)					
ISOLATION	INPUT-OUTPUT-RC *3	AC4,000V 1minute, Cutoff current = 10mA, DC500V 50MΩ min (At Room Temperature)					
	INPUT-FG	AC2,000V 1minute, Cutoff current = 10mA, DC500V 50MΩ min (At Room Temperature)					
	OUTPUT-RC-FG *3	AC500V 1minute, Cutoff current = 25mA, DC500V 50MΩ min (At Room Temperature)					
ENVIRONMENT	OPERATING TEMP.,HUMID.AND ALTIITUDE	-10 to +70°C, 20 - 90%RH (Non condensing), 3,000m (10,000feet) max *4					
	STORAGE TEMP.,HUMID.AND ALTIITUDE	-20 to +75°C, 20 - 90%RH (Non condensing), 9,000m (30,000feet) max					
	VIBRATION	10 - 55Hz, 19.6m/s ² (2G), 3minutes period, 60minutes each along X, Y and Z axis					
	IMPACT	196.1m/s ² (20G), 11ms, once each X, Y and Z axis					
SAFETY AND NOISE REGULATIONS	AGENCY APPROVALS	UL60601-1, C-UL (CSA-C22.2 No.601.1), EN60601-1					
	CONDUCTED NOISE	Complies with FCC-B, VCCI-B, CISPR11-B, CISPR22-B, EN55011-B, EN55022-B					
	HARMONIC ATTENUATOR	Complies with IEC61000-3-2 *6					
OTHERS	CASE SIZE/WEIGHT	32 X 82 X 135mm [1.26 X 3.23 X 5.31 inches] (W X H X D) / 350g max (with cover : 395g max)					
	COOLING METHOD	Convection					

*1 Measured by 20MHz oscilloscope or Ripple-Noise meter (equivalent to KEISOKU-GIKEN: RM101).
 *2 Drift is the change in DC output for an eight hour period after a half-hour warm-up at 25°C.
 *3 Applicable when Remote ON/OFF (optional) is added. RC is insulated with input, output and FG.
 *4 Refer to "Derating".
 *5 Please contact us about safety approvals for the model with option.

*6 Please contact us about class C.
 * Parallel operation with other model is not possible.
 * Derating is required when operated with cover.
 * A sound may occur from power supply at peak loading.

Block diagram

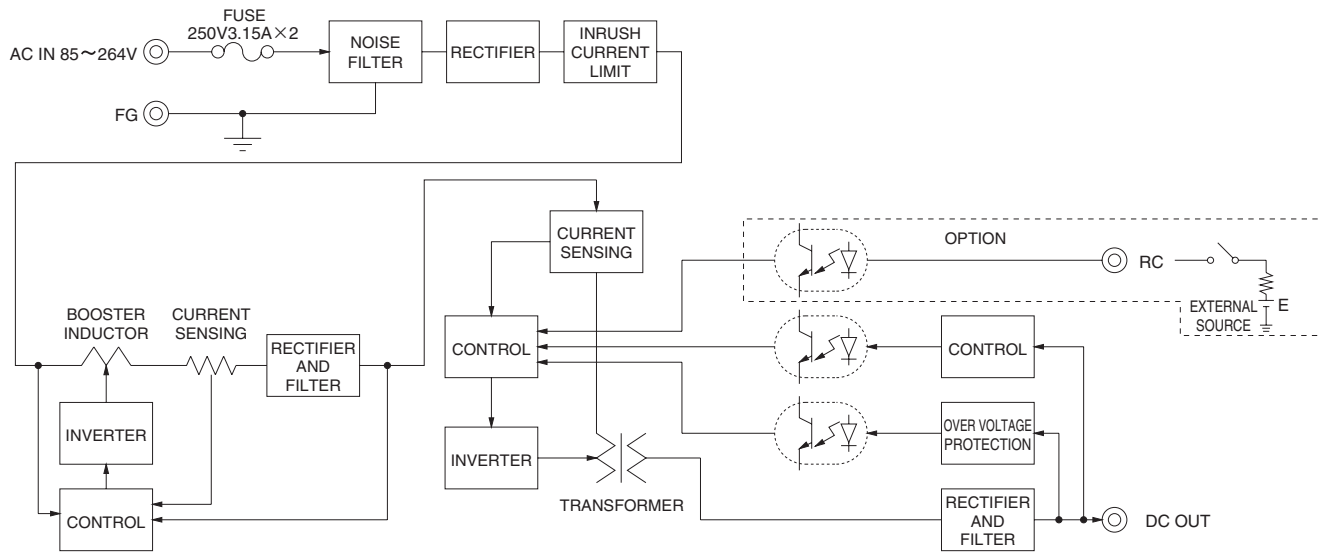

External view

※ External size of option T and T1 is different from standard model and refer to 5 Option of instruction manual for details.

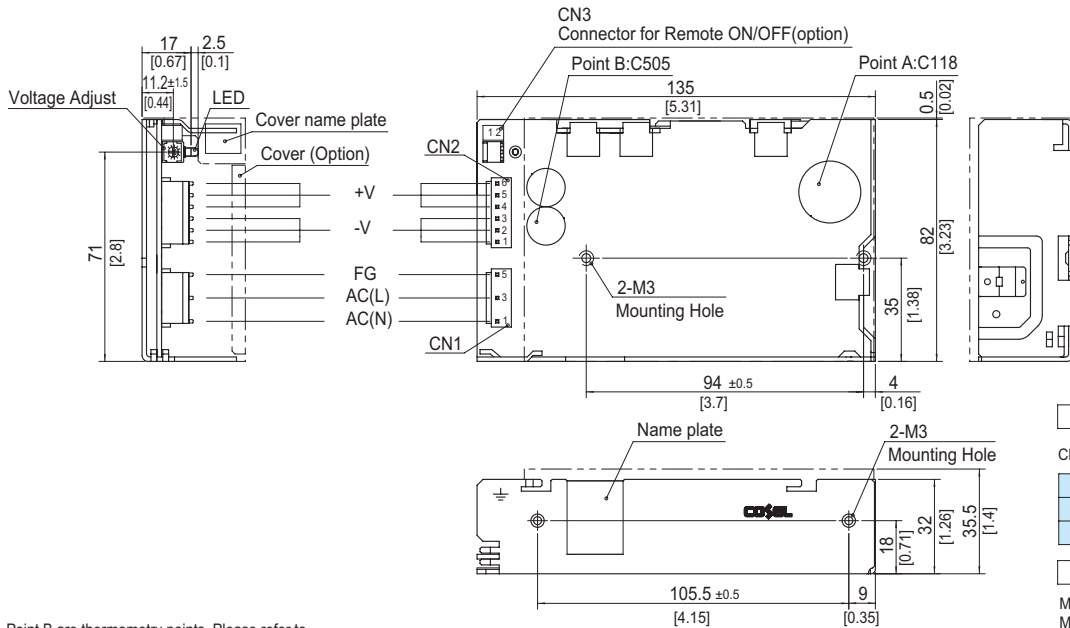

※ Point A, Point B are thermometry points. Please refer to Instruction Manual 3.

I/O Connector	Mating Connector	Terminal
CN1	1-1123724-3	1-1123722-5 Chain 1123721-1
		Loose 1318912-1
CN2	1-1123723-6	1-1123722-6 Chain 1123721-1
		Loose 1318912-1

(Mfr : Tyco Electronics AMP)

※ I/O Connector is Mfr. Tyco Electronics AMP
 ※ Option : -J1 : (J.S.T) connector type
 -T : Vertical terminal block type
 -T1 : Horizontal terminal block type
 Refer to Instruction Manual 5.

<PIN CONNECTION>

Pin No.	Input
1	AC(N)
2	
3	AC(L)
4	
5	FG

Pin No.	Output
1 - 3	-V
4 - 6	+V

- ※ Tolerance : ±1 [±0.04]
- ※ Weight : 350g max (with cover : 395g max)
- ※ PCB Material/thickness : CEM-3 / 1.6mm [0.06inches]
- ※ Chassis material : Aluminum
- ※ Keep drawing current per pin below 5A of CN2.
- ※ Dimensions in mm, [] =inches
- ※ Mounting torque : 0.49N · m (5kgf · cm) max
- ※ Please connect safety ground to the unit in 2-M3 holes.

Connector type	
CN3 Option (Mfr:J.S.T)	
PIN No.	Contents
1	RC(+)
2	RC(-)
Barrier strip type	
Model B2B-XH-A	
Mating Connector (Terminal)	
XHP-2	
(BXH-001T-P0.6 or SXH-001T-P0.6)	

PMA100F

① PM ② A ③ 100 ④ F ⑤ -□ ⑥ -□



RoHS

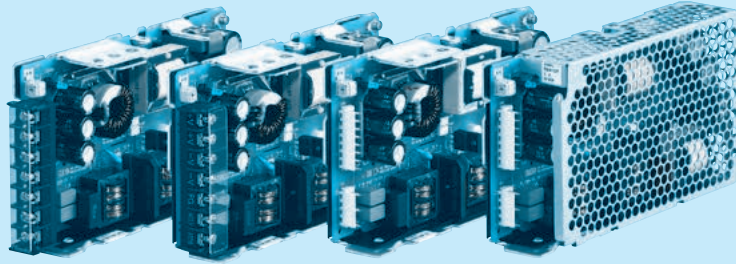

Horizontal terminal block (option : -T1) Vertical terminal block (option : -T) Standard type with Cover (option : -N)

Example recommended EMI/EMC filter
NAM-06-000



Low leakage current type : NAM series
* A higher current rating EMI/EMC filter may be recommended in view of the other devices that could be connected in parallel with the power supply.

- ① Series name
- ② Single output
- ③ Output wattage
- ④ Universal input
- ⑤ Output voltage
- ⑥ Optional *5
- T : Vertical terminal block
- T1 : Horizontal terminal block
- N : with Cover
- J1 : VH(J.S.T.)connector type
- R : with Remote ON/OFF

Specification is changed at option, refer to Instruction Manual.

*Make sure necessary tests will be carried out on your end equipment with the power supply installed in accordance with any required EMC/EMI regulations.

MODEL	PMA100F-3R3	PMA100F-5	PMA100F-12	PMA100F-24	PMA100F-48
MAX OUTPUT WATTAGE[W]	66	100	102	108	100.8
DC OUTPUT	3.3V 20A	5V 20A	12V 8.5A	24V 4.5A	48V 2.1A

SPECIFICATIONS

	MODEL	PMA100F-3R3	PMA100F-5	PMA100F-12	PMA100F-24	PMA100F-48	
INPUT	VOLTAGE[V]	AC85 - 264 1 φ (Refer to the Instruction Manual 1.1)					
	CURRENT[A]	ACIN 100V	0.9typ (Io=100%)	1.3typ (Io=100%)			
		ACIN 200V	0.5typ (Io=100%)	0.7typ (Io=100%)			
	FREQUENCY[Hz]	50 / 60 (47 - 63)					
	EFFICIENCY[%]	ACIN 100V	77typ	81typ	82typ	84typ	84typ
		ACIN 200V	78typ	83typ	83typ	86typ	86typ
	POWER FACTOR (Io=100%)	ACIN 100V	0.98typ				
		ACIN 200V	0.85typ	0.90typ			
INRUSH CURRENT[A]	ACIN 100V	20typ (Io=100%) (At cold start)					
	ACIN 200V	40typ (Io=100%) (At cold start)					
LEAKAGE CURRENT[mA]	0.09 / 0.18max (ACIN 100V / 240V 60Hz, Io=100%, According to IEC60601-1)						
OUTPUT	VOLTAGE[V]	3.3	5	12	24	48	
	CURRENT[A]	20.0	20.0	8.5	4.5	2.1	
	LINE REGULATION[mV]	20max	20max	48max	96max	192max	
	LOAD REGULATION[mV]	40max	40max	100max	150max	240max	
	RIPPLE[mVp-p]	0 to +50°C	80max	80max	120max	150max	150max
		*1 -10 -0°C	140max	140max	160max	160max	200max
	RIPPLE NOISE[mVp-p]	0 to +50°C	120max	120max	150max	150max	250max
		*1 -10 -0°C	160max	160max	180max	180max	300max
	TEMPERATURE REGULATION[mV]	0 to +50°C	50max	50max	120max	240max	480max
		*1 -10 to +50°C	60max	60max	150max	290max	600max
	DRIFT[mV]	*2	20max	20max	48max	96max	192max
	START-UP TIME[ms]	250typ (ACIN 100V, Io=100%)					
	HOLD-UP TIME[ms]	20typ (ACIN 100V, Io=100%)					
OUTPUT VOLTAGE ADJUSTMENT RANGE[V]	2.85 to 3.60	4.50 to 5.50	10.00 to 13.20	19.20 to 27.00	39.00 to 53.00		
OUTPUT VOLTAGE SETTING[V]	3.30 to 3.40	5.00 to 5.15	12.00 to 12.48	24.00 to 24.96	48.00 to 49.92		
PROTECTION CIRCUIT AND OTHERS	OVERCURRENT PROTECTION	Works over 105% of rating and recovers automatically					
	OVERVOLTAGE PROTECTION[V]	4.00 to 5.25	5.75 to 7.00	15.00 to 18.00	30.00 to 37.00	58.00 to 65.00	
	OPERATING INDICATION	LED (Green)					
	REMOTE ON/OFF	Optional (Required external power source)					
ISOLATION	INPUT-OUTPUT-RC	*3	AC4,000V 1minute, Cutoff current = 10mA, DC500V 50MΩ min (At Room Temperature)				
	INPUT-FG		AC2,000V 1minute, Cutoff current = 10mA, DC500V 50MΩ min (At Room Temperature)				
	OUTPUT-RC-FG	*3	AC500V 1minute, Cutoff current = 25mA, DC500V 50MΩ min (At Room Temperature)				
ENVIRONMENT	OPERATING TEMP.,HUMID.AND ALTITUDE	-10 to +70°C, 20 - 90%RH (Non condensing), 3,000m (10,000feet) max *4					
	STORAGE TEMP.,HUMID.AND ALTITUDE	-20 to +75°C, 20 - 90%RH (Non condensing), 9,000m (30,000feet) max					
	VIBRATION	10 - 55Hz, 19.6m/s ² (2G), 3minutes period, 60minutes each along X, Y and Z axis					
	IMPACT	196.1m/s ² (20G), 11ms, once each X, Y and Z axis					
SAFETY AND NOISE REGULATIONS	AGENCY APPROVALS	UL60601-1, C-UL (CSA-C22.2 No.601.1), EN60601-1					
	CONDUCTED NOISE	Complies with FCC-B, VCCI-B, CISPR11-B, CISPR22-B, EN55011-B, EN55022-B					
	HARMONIC ATTENUATOR	Complies with IEC61000-3-2 *6					
OTHERS	CASE SIZE/WEIGHT	34 X 93 X 168mm [1.34 X 3.66 X 6.61 inches] (W X H X D) / 560g max (with cover : 625g max)					
	COOLING METHOD	Convection					

*1 Measured by 20MHz oscilloscope or Ripple-Noise meter (equivalent to KEISOKU-GIKEN: RM101).
 *2 Drift is the change in DC output for an eight hour period after a half-hour warm-up at 25°C.
 *3 Applicable when Remote ON/OFF (optional) is added. RC is insulated with input, output and FG.
 *4 Refer to "Derating".
 *5 Please contact us about safety approvals for the model with option.

*6 Please contact us about class C.
 * Parallel operation with other model is not possible.
 * Derating is required when operated with cover.
 * A sound may occur from power supply at peak loading.

Block diagram

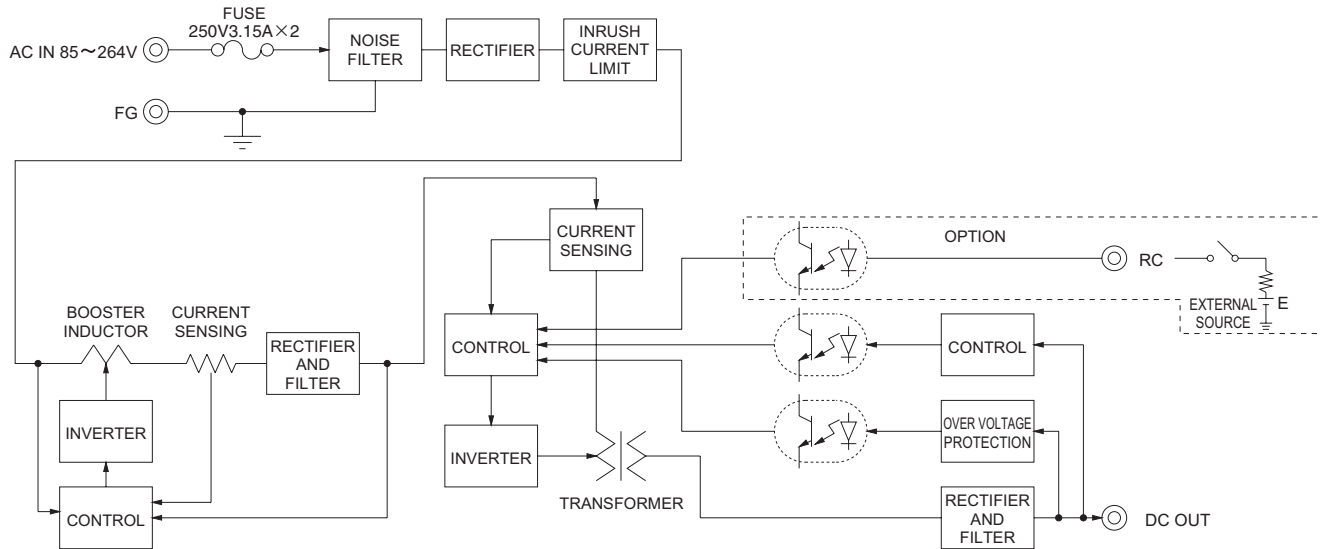

External view

※ External size of option T and T1 is different from standard model and refer to 5 Option of instruction manual for details.

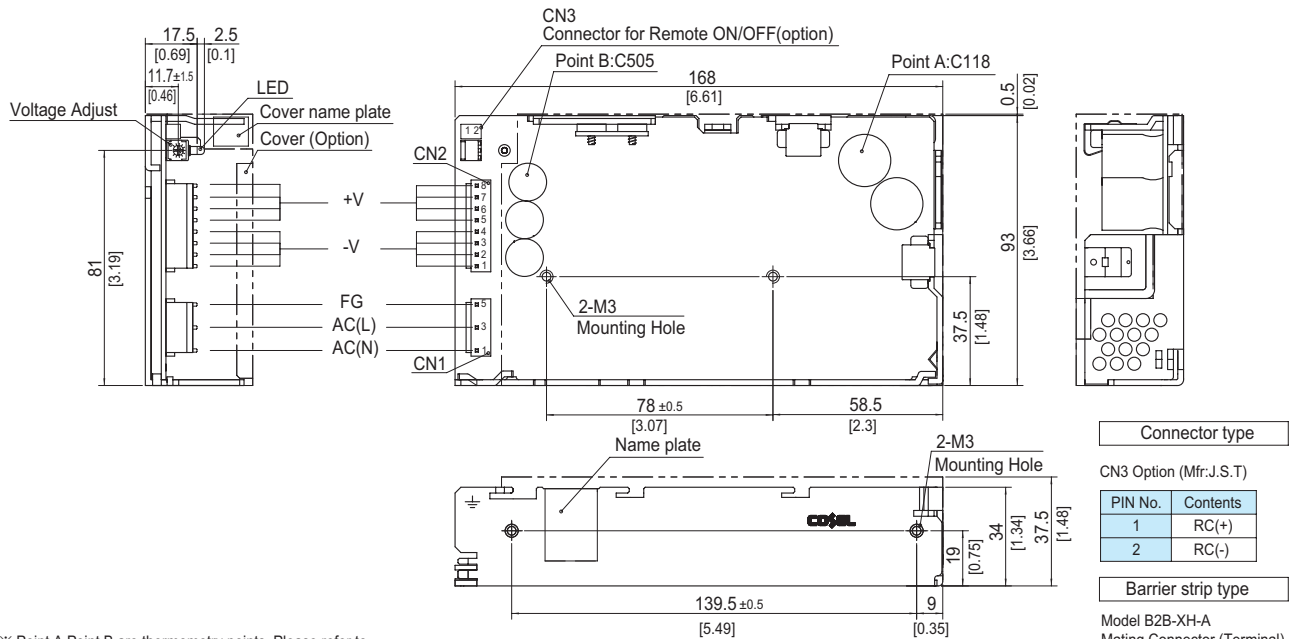

※ Point A, Point B are thermometry points. Please refer to Instruction Manual 3.

I/O Connector	Mating Connector	Terminal
CN1	1-1123724-3	1-1123722-5
		Chain 1123721-1
		Loose 1318912-1
CN2	1-1123723-8	1-1123722-8
		Chain 1123721-1
		Loose 1318912-1

(Mfr: Tyco Electronics AMP)

※ I/O Connector is Mfr. Tyco Electronics AMP
 ※ Option: -J1 : (J.S.T) connector type
 -T : Vertical terminal block type
 -T1 : Horizontal terminal block type
 Refer to Instruction Manual 5.

<PIN CONNECTION>

Pin No.	Input
1	AC(N)
2	
3	AC(L)
4	
5	FG

Pin No.	Output
1 - 4	-V
5 - 8	+V

※ Tolerance : ± 1 [± 0.04]
 ※ Weight : 560g max (with cover : 625g max)
 ※ PCB Material/thickness : CEM-3 / 1.6mm [0.06inches]
 ※ Chassis material : Aluminum
 ※ Keep drawing current per pin below 5A of CN2.
 ※ Dimensions in mm, [] =inches
 ※ Mounting torque : 0.49N · m (5kgf · cm) max
 ※ Please connect safety ground to the unit in 2-M3 holes.

Connector type	
CN3 Option (Mfr:J.S.T)	
PIN No.	Contents
1	RC(+)
2	RC(-)
Barrier strip type	
Model B2B-XH-A	
Mating Connector (Terminal)	
XHP-2	
(BXH-001T-P0.6 or SXH-001T-P0.6)	

Assembling and Installation Method

Installation method

■ Do not insert a screw more than 6mm from the outside of a power supply to keep enough insulation distance between the screw and internal components.

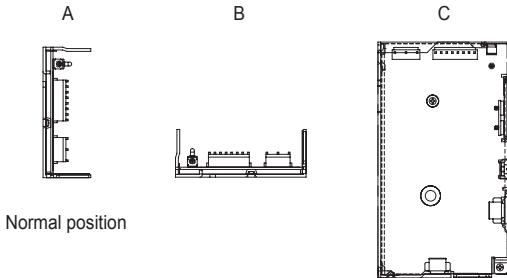

Normal position

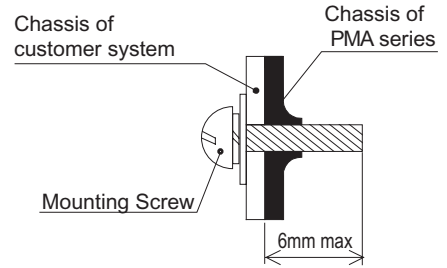

- If you use two or more power supplies side by side, please keep a sufficient distance between them to allow enough air ventilation.
- Ambient temperature around each power supply should not exceed the temperature range shown in “Derating”.

Derating

● PMA15F, PMA30F Input voltage Derating Curve

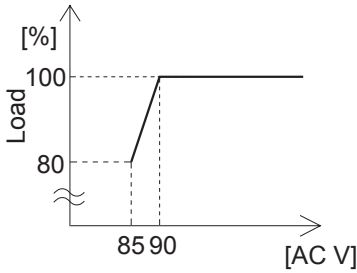

● Ambient temperature Derating Curve (Reference value)

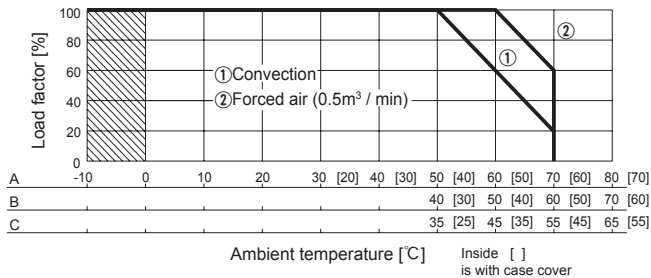

- In the hatched area, the specification of Ripple, Ripple Noise is different from other area.
- The ambient temperature should be measured 5 to 10 cm away from the power supply so that it won't be influenced by the heat from the power supply. Please consult us for more details.
- Make sure the temperature at point A and point B is less than the temperatures shown in Instruction Manual 3.

Instruction Manual

◆ It is necessary to read the “Instruction Manual” and “Before using our product” before you use our product.

Instruction Manual <https://www.cosel.co.jp/redirect/catalog/en/PMA/>
 Before using our product <https://en.cosel.co.jp/technical/caution/index.html>

PMA



NOTICE



Basic Characteristics Data

Model	Circuit method	Switching frequency [kHz]	Input current [A] *1	Inrush current protection	PCB/Pattern			Series/Parallel operation availability *2	
					Material	Single sided	Double sided	Series operation	Parallel operation
PMA15F	Flyback converter	100	0.4	Thermistor	CEM-3	Yes		Yes	No
PMA30F	Flyback converter	100	0.7	Thermistor	CEM-3	Yes		Yes	No
PMA60F	Active filter	60 - 550	0.8	Thermistor	CEM-3	Yes		Yes	No
	Forward converter	120							
PMA100F	Active filter	60 - 550	1.3	Thermistor	CEM-3	Yes		Yes	No
	Forward converter	120							

*1 The value of input current is at ACIN 100V and rated load.

*2 Refer to Instruction Manual 2.

EMI/EMC Filter Contents

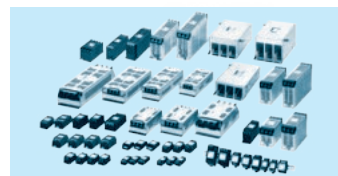

Single-phase type

	Rated voltage	Series	Rated current [A]									Released year	Option		
			3A	4A	6A	10A	16A	20A	30A	40A	50A		60A	D	F
1-stage	AC250V	EAC	●	—	●	●	●	●	●	—	—	—	'10	●	—
	AC250V	EAM	●	—	●	●	●	●	●	—	—	—	'10	●	—
	AC250V	EAP	●	—	●	●	●	●	●	—	—	—	'10	●	—
	AC250V	ESC	●	—	●	●	●	—	—	—	—	—	'10	●	—
	AC250V	ESM	●	—	●	●	●	—	—	—	—	—	'10	●	—
	AC250V	ESP	●	—	●	●	●	—	—	—	—	—	'10	●	—
	AC250V	NAC	—	●	●	●	●	●	—	—	—	—	'05	●	—
	AC250V	NAM	—	●	●	●	●	●	●	—	—	—	'05	●	—
	AC250V	NAH	—	—	●	●	●	●	●	—	—	—	'06	●	—
	AC250V	NAP	—	●	●	●	●	●	●	—	—	—	'05	●	—
	AC277V DC300V	NAC	—	—	—	—	—	—	—	●	●	●	NEW '21	—	●
	AC277V DC300V	NAM	—	—	—	—	—	—	—	●	●	●	NEW '21	—	—
AC277V DC300V	NAH	—	—	—	—	—	—	—	●	●	●	NEW '21	—	●	
AC277V DC300V	NAP	—	—	—	—	—	—	—	●	●	●	NEW '21	—	●	
2-stage	AC250V	NBH	—	—	●	●	●	●	●	—	—	—	'07	●	—
	AC250V	NBC	—	—	●	●	●	●	●	—	—	—	'07	●	—
	AC250V	NBM	—	—	●	●	●	●	●	—	—	—	'07	●	—

Option -D: DIN rail installation type -F: High input voltage (Rated voltage 500VAC/600VDC)

Three-phase type

	Rated voltage	Series	Rated current [A]																	Released year	Option																	
			4A	6A	10A	20A	25A	30A	36A	40A	50A	60A	64A	80A	100A	125A	150A	200A	250A		300A	400A	600A	800A	1000A	D	G	H	L	S	U							
1-stage	three-wire	AC500V	JAC	—	●	●	●	—	●	—	—	—	—	—	—	—	—	—	—	—	—	—	—	—	—	—	—	—	—	—	'14	●	—	●	—	—	●	
		AC500V	TAC	●	●	●	●	—	●	—	—	—	—	—	—	—	—	—	—	—	—	—	—	—	—	—	—	—	—	—	—	'19	—	—	●	—	—	●
		AC500V	TAH	●	●	●	●	—	●	—	—	—	—	—	—	—	—	—	—	—	—	—	—	—	—	—	—	—	—	—	—	'05	●	—	—	—	—	—
		AC500V	TAC	—	—	—	—	—	—	—	—	—	—	—	—	—	—	—	—	—	—	—	—	—	—	—	—	—	—	—	—	'06	—	—	—	—	—	—
		AC500V	TAH	—	—	—	—	—	—	—	—	—	—	—	—	—	—	—	—	—	—	—	—	—	—	—	—	—	—	—	—	'08	—	—	—	—	—	—
		AC500V	TAC	—	—	—	—	—	—	—	—	—	—	—	—	—	—	—	—	—	—	—	—	—	—	—	—	—	—	—	—	'09	—	—	—	—	—	—
	four-wire	AC500V	FTA	—	—	—	—	—	—	—	—	—	—	—	—	—	—	—	—	—	—	—	—	—	—	—	—	—	—	—	'13	—	—	●	●	—	—	●
		AC500V	TAC	—	—	—	—	—	—	—	—	—	—	—	—	—	—	—	—	—	—	—	—	—	—	—	—	—	—	—	'11	—	—	●	●	—	—	●
		AC500V	YAC	—	—	—	—	—	—	—	—	—	—	—	—	—	—	—	—	—	—	—	—	—	—	—	—	—	—	—	NEW '23	—	—	—	—	—	—	
		AC500V	TBC	—	—	—	—	—	—	—	—	—	—	—	—	—	—	—	—	—	—	—	—	—	—	—	—	—	—	—	'08	—	—	—	—	—	—	
		AC500V	FTB	—	—	—	—	—	—	—	—	—	—	—	—	—	—	—	—	—	—	—	—	—	—	—	—	—	—	—	'09	—	—	—	—	—	—	
		AC500V	FSB	—	—	—	—	—	—	—	—	—	—	—	—	—	—	—	—	—	—	—	—	—	—	—	—	—	—	—	'11	—	—	—	—	—	—	
2-stage	AC500V	FSB	—	—	—	—	—	—	—	—	—	—	—	—	—	—	—	—	—	—	—	—	—	—	—	—	—	—	'16	—	—	—	—	—	—			
	AC500V	FSB	—	—	—	—	—	—	—	—	—	—	—	—	—	—	—	—	—	—	—	—	—	—	—	—	—	—	'18	—	—	—	—	—	—			
	AC500V	FSB	—	—	—	—	—	—	—	—	—	—	—	—	—	—	—	—	—	—	—	—	—	—	—	—	—	—	'17	—	—	—	—	—	—			
multi-stage	AC500V	TSC	—	—	—	—	—	—	—	—	—	—	—	—	—	—	—	—	—	—	—	—	—	—	—	—	—	—	'13	—	—	—	—	—	—			
	AC500V	TSD	—	—	—	—	—	—	—	—	—	—	—	—	—	—	—	—	—	—	—	—	—	—	—	—	—	—	NEW '21	—	—	—	—	—	—			
																													NEW '23	—	—	—	—	—	—			

Option -D: DIN rail installation type -G: With switch of line to ground capacitor -H: Ultra high-attenuation type
 -L: Ultra high-attenuation type for EU -S: Hexagon socket head cap screw -U: Improve differential mode attenuation (Rated voltage 250V)
 (Standard type is Hexagon head screw)













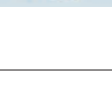

DC type

	Rated voltage	Series	Rated current [A]				Released year	Option	
			1A	3A	6A	10A		D	T
1-stage	DC±50V	SNA	●	—	●	—	'05	●	● (Excluding 1A and 3A)
	DC50V	SNR	—	—	—	●	'07	●	●

Option -D: DIN rail installation type -T: Terminal block type

EMI/EMC Filter Selection Guide by Type

Refer to EMI/EMC filter selection flow chart for options.

Series	Features		Rated Voltage (voltage range max)	Rated Current																				
				1	3	4	6	10	16	20	25	30	36	40	50	60	64	80	100	125	150	200	250	300
Single-phase EMI/EMC filter	 EA Series 1-stage filter	Small size	Screw type	EAC: Attenuation for low frequency band (150kHz to 1MHz) EAM: Low leakage current EAP: Outside impulse attenuation	250VAC	3A 6A 10A 16A 20A 30A																		
	 ES Series 1-stage filter	Small size	Screwless type	ESC: Attenuation for low frequency band (150kHz to 1MHz) ESM: Low leakage current ESP: Outside impulse attenuation	250VAC	3A 6A 10A 16A																		
	 NA Series 1-stage filter	General purpose	Screw type	NAC: High-attenuation for low frequency band (150kHz to 1MHz) NAM: Low leakage current NAH: Ultra high-attenuation for ultra low frequency band (9kHz to 1MHz) NAP: Outside impulse high-attenuation	250VAC	4A 6A 10A 16A 20A 30A * NAH only, 6A to 30A																		
	 NB Series 2-stage filter			High-attenuation	NBC: High-attenuation for low frequency band (150kHz to 1MHz) NBM: Low leakage current, Withstand voltage 4,000VAC NBH: Ultra high-attenuation and broadband (9kHz to 10MHz)	250VAC	6A 10A 16A 20A 30A																	
Three-phase EMI/EMC filter	 JAC Series 1-stage filter	Compact and low profile	General purpose	High-attenuation for low frequency band (150kHz to 1MHz)	500VAC (528VAC)	6A 10A 20A 30A 40A 50A 60A																		
	 TAC Series 1-stage filter			High-attenuation for low frequency band (150kHz to 1MHz)	500VAC (528VAC)	4A 6A 10A 20A 30A 50A 60A 80A 100A 150A 200A 250A 300A																		
	 TAH Series 1-stage filter	Low profile	Ultra high-attenuation for ultra low frequency band (9kHz to 10MHz)	500VAC (528VAC)	4A 6A 10A 20A 30A 50A 60A 80A 100A 150A																			
	 TBC Series 2-stage filter	High-attenuation	High-attenuation for low frequency band (150kHz to 1MHz)	500VAC (528VAC)	50A 60A 80A 100A 150A 200A 250A 300A																			
	 FTA Series 1-stage filter	Book type (Space-saving type)	General purpose	High-attenuation for low frequency band (150kHz to 1MHz)	500VAC (528VAC)	40A 50A 60A 80A 100A 125A 150A																		
	 FTB Series 2-stage filter		High-attenuation	Ultra high-attenuation for low frequency band (150kHz to 1MHz)	500VAC (528VAC)	80A 100A 150A																		
	 FSB Series 2-stage filter	Low profile	Saturation resistance type	EMI/EMC Filter for motor drive system (AC servo) Improve saturation resistance	500VAC (528VAC)	10A 20A 30A 40A 50A 60A 80A 100A 150A																		
	 TSC Series multi-stage filter		Ultra high-attenuation	Ultra high-attenuation from 150kHz to 1MHz	500VAC (528VAC)	400A 600A																		
	 TSD Series multi-stage filter		Saturation resistance type	Ultra high-attenuation from 150kHz to 1MHz	500VAC (528VAC)	400A 600A 800A 1000A																		
	 YAC Series 1-stage filter	General purpose	General purpose	High-attenuation for low frequency band (150kHz to 1MHz)	500/289VAC (528/305VAC)	25A 36A 64A 80A																		
DC EMI/EMC filter	 SNA Series 1-stage filter	Ripple noise attenuation for switch mode power supplies	For ±V output power supply	DC±50V	1A 3A 6A																			
	 SNR Series 1-stage filter		For +V output power supply (Peak load)	DC50V	10A																			

EMI/EMC Filter Selection Guide by Function

Refer to EMI/EMC filter selection flow chart for options.

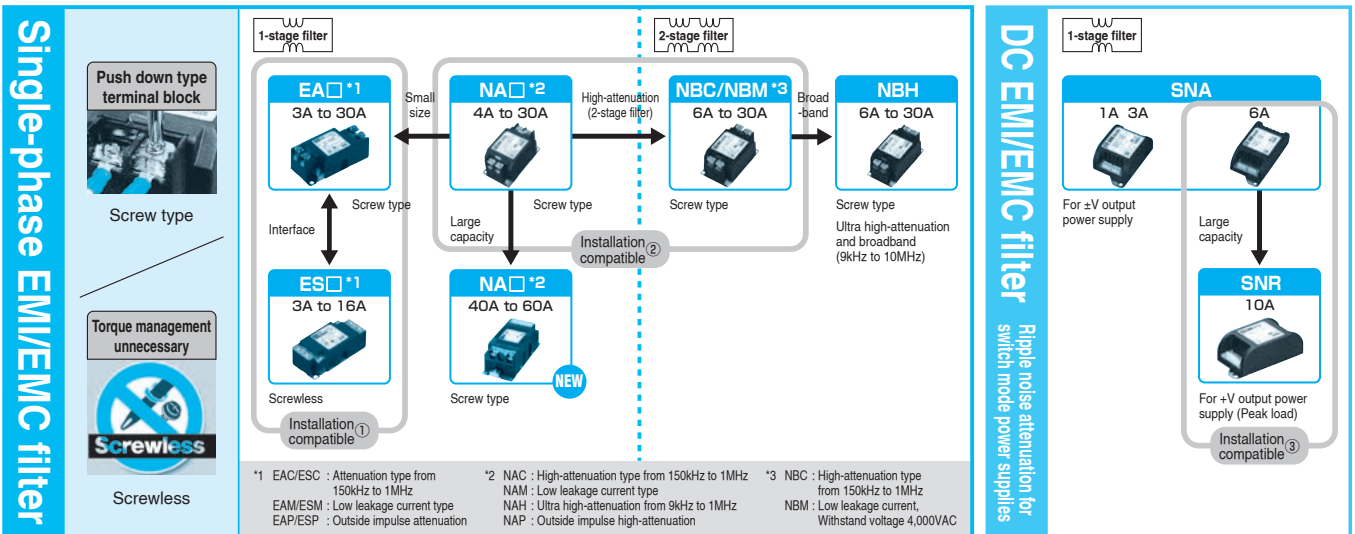
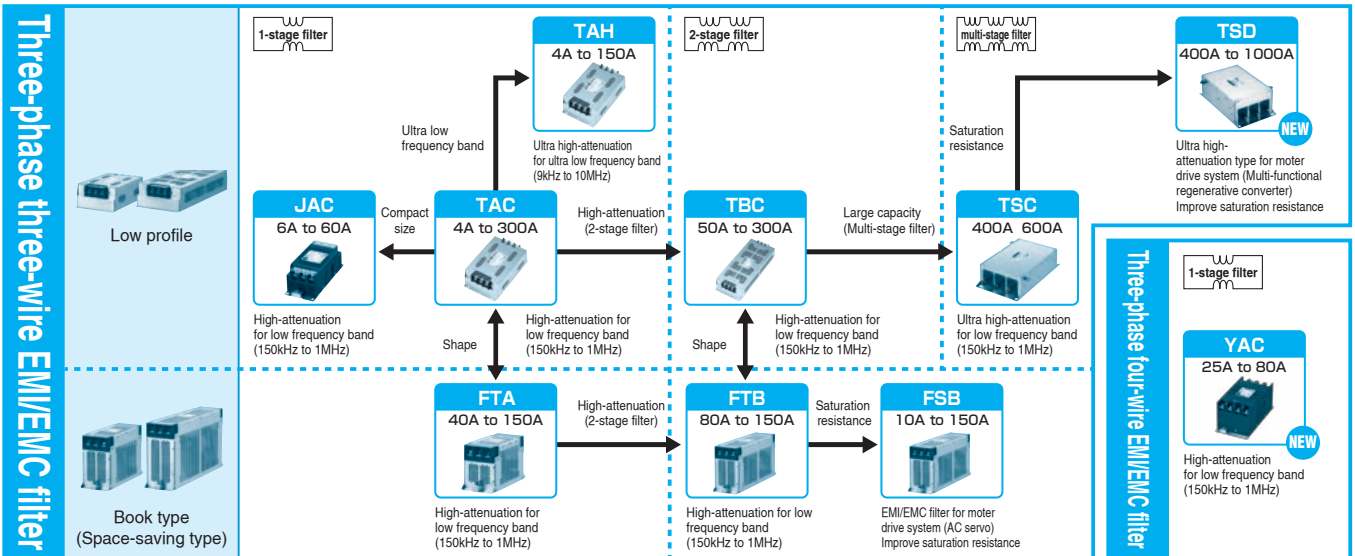
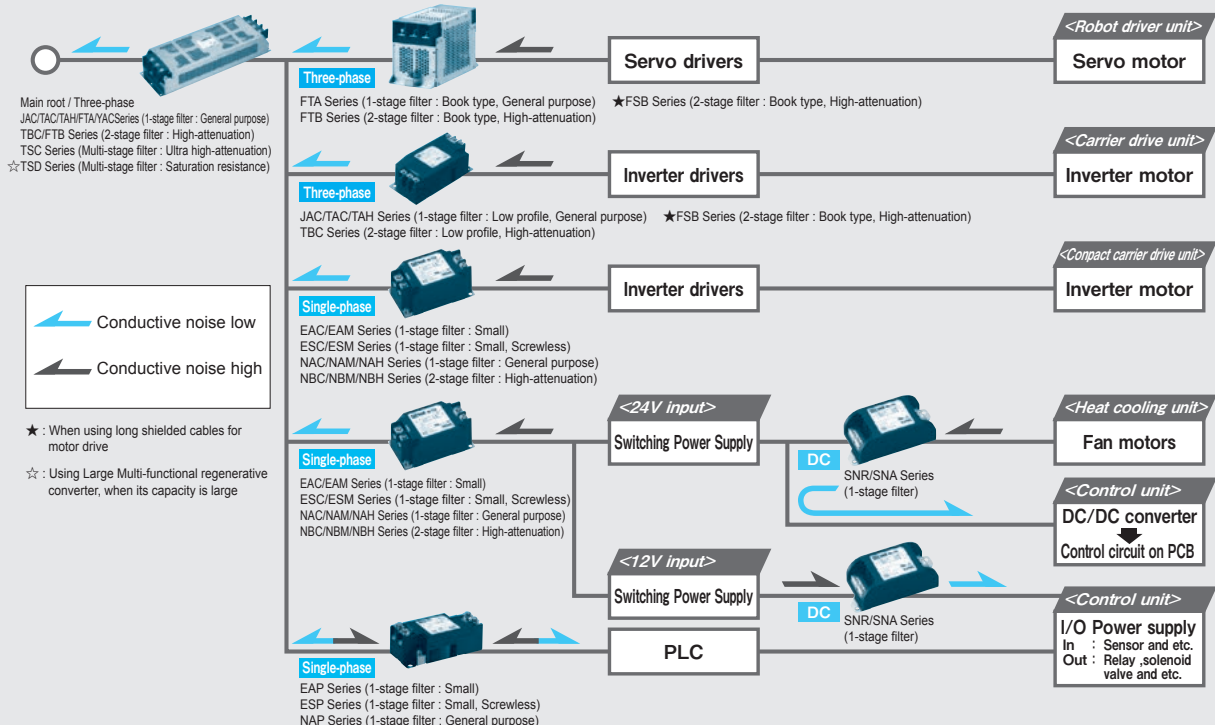

Diagram of Sample application



EMI/EMC Filter Selection flow chart

By using the flow chart below, you can easily select the model you need.

START

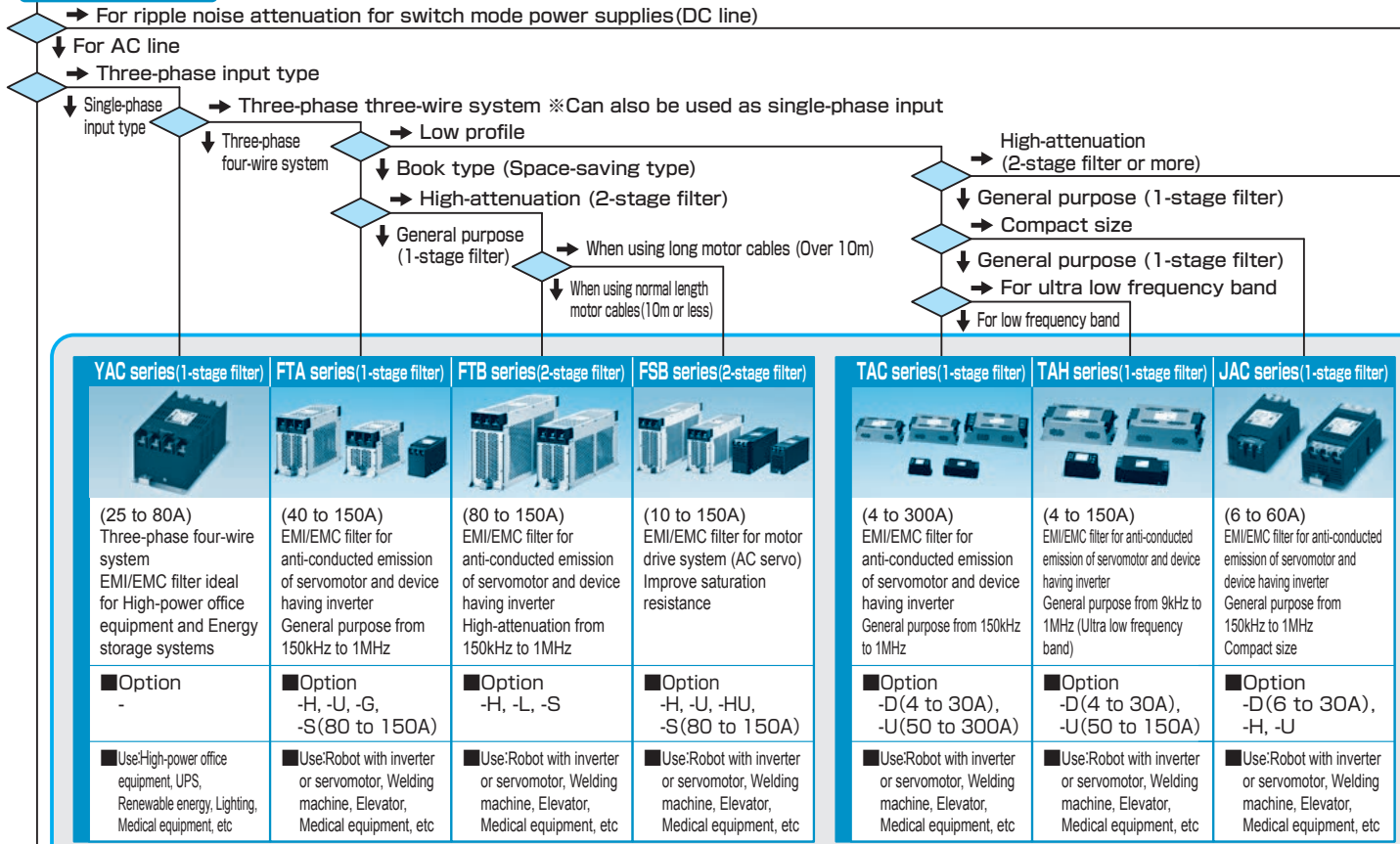

Three-phase EMI/EMC filter

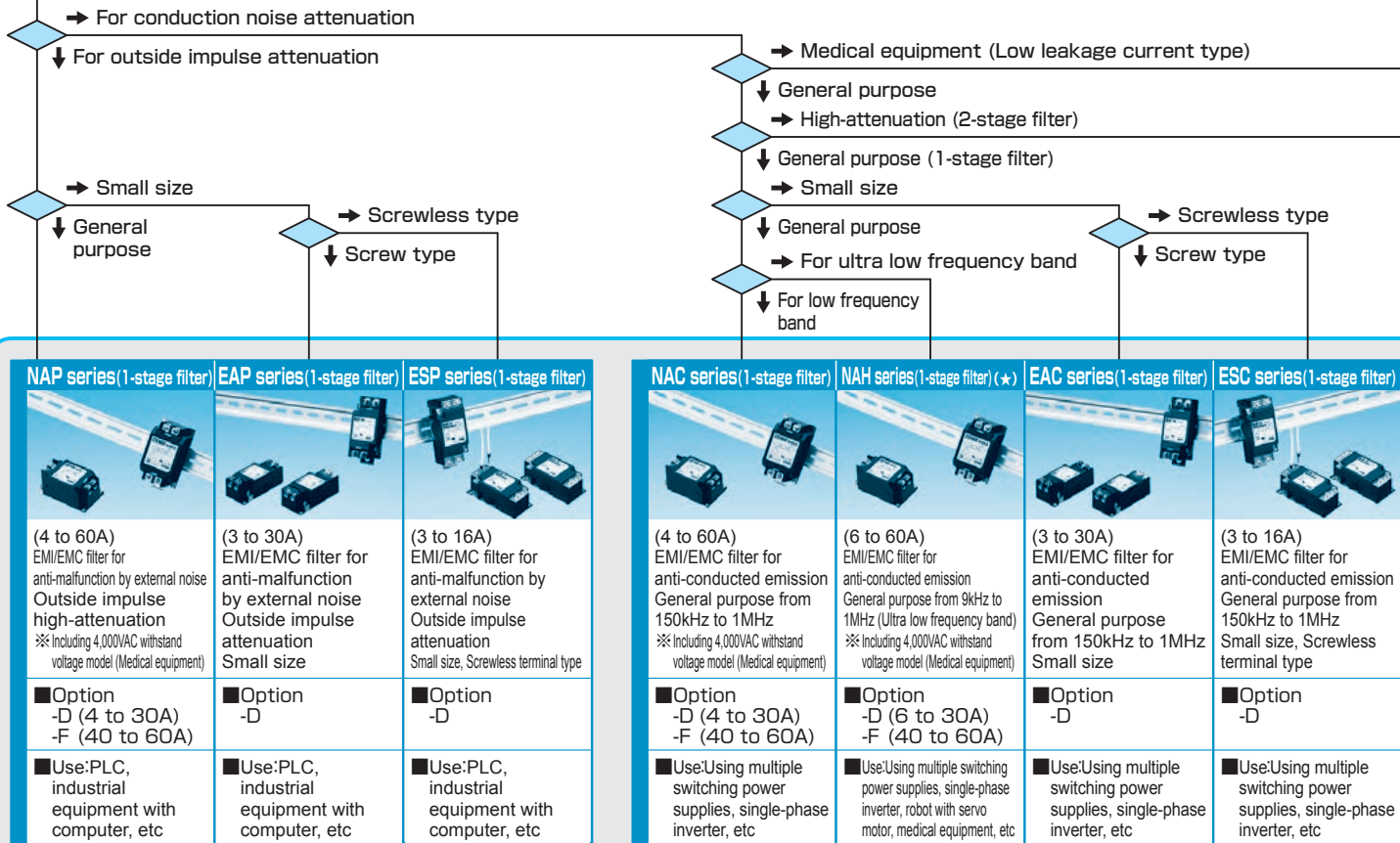

Single-phase EMI/EMC filter

■Option

- D : DIN rail installation type
- G : With switch of line to ground capacitor
- L : Ultra high-attenuation type for EU
- T : Terminal block type

- F : High input voltage (Rated voltage 500VAC/600VDC)
- H : Ultra high-attenuation type
- S : Hexagon socket head cap screw (Standard type is Hexagon head screw)
- U : Improve differential mode attenuation (Rated voltage 250V)

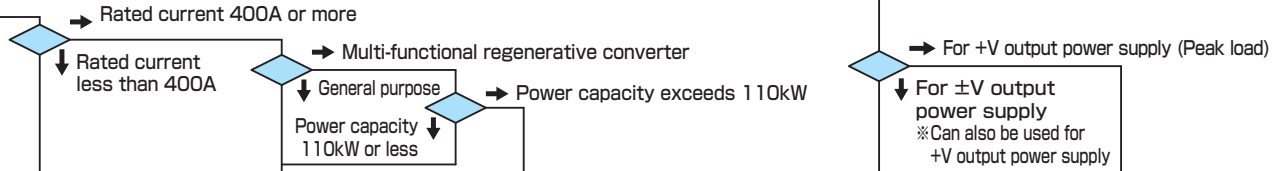

TBC series(2-stage filter)	TSC series(multi-stage filter)	TSD series(multi-stage filter)
(50 to 300A) EMI/EMC filter for anti-conducted emission of servomotor and device having inverter High-attenuation from 150kHz to 1MHz	(400, 600A) EMI/EMC filter for anti-conducted emission of servomotor and device having inverter Ultra high-attenuation from 150kHz to 1MHz	(400 to 1000A) Ultra high-attenuation for motor drive system (Multi-functional regenerative converter) Improve saturation resistance
■Option —	■Option ※1 -H	■Option ※1 —
■Use:Robot with inverter or servomotor, Welding machine, Elevator, Medical equipment, etc	■Use:Robot with inverter or servomotor, Welding machine, Elevator, Medical equipment, etc	■Use:Large equipment with Multi-functional regenerative converter (Transferred equipment, air conditioning equipment), etc

※1 Please contact us about low leakage current type (Change to low grounding capacitor)

SNA series(1-stage filter)	SNR series(1-stage filter)
(1, 3, 6A) Ripple noise attenuation for switch mode power supplies (DC+50V)	(10A) Ripple noise attenuation for switch mode power supplies (DC+50V)
■Option -D, -T(6A), -DT(6A)	■Option -D, -T, -DT
■Use:DC EMI/EMC filter for ±V output power supply of analog circuit (Operational amplifier etc.)	■Use:DC EMI/EMC filter for +V output power supply of analog circuit

DC EMI/EMC filter

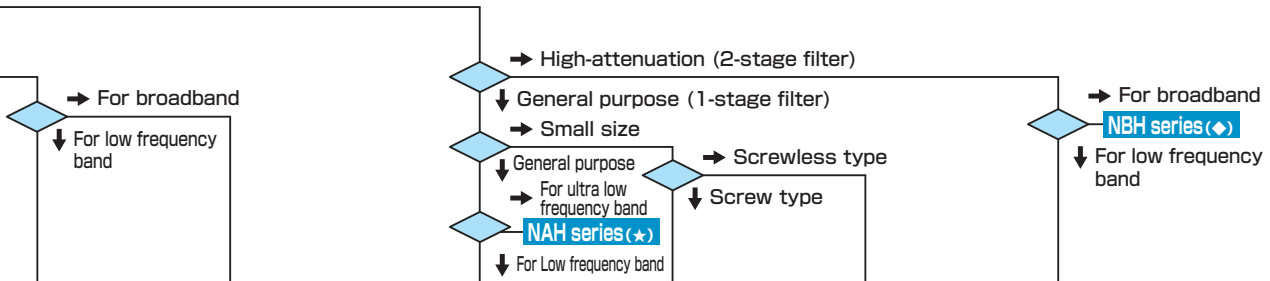

NBC series(2-stage filter)	NBH series(2-stage filter) (diamond)	NAM series(1-stage filter)	EAM series(1-stage filter)	ESM series(1-stage filter)	NBM series(2-stage filter)
(6 to 30A) EMI/EMC filter for anti-conducted emission High-attenuation from 150kHz to 1MHz	(6 to 30A) EMI/EMC filter for anti-conducted emission Ultra high-attenuation and broadband from 9kHz to 10MHz ※Including 4,000VAC withstand voltage model (Medical equipment)	(4 to 60A) EMI/EMC filter for medical applications Low leakage current type General purpose from 150kHz to 1MHz ※Including 4,000VAC withstand voltage model	(3 to 30A) EMI/EMC filter for medical applications Low leakage current type General purpose from 150kHz to 1MHz Small size	(3 to 16A) EMI/EMC filter for medical applications Low leakage current type General purpose from 150kHz to 1MHz Small size, Screwless terminal type	(6 to 30A) EMI/EMC filter for medical applications Low leakage current type General purpose from 150kHz to 1MHz with stand voltage 4,000VAC
■Option -D	■Option -D	■Option -D (4 to 30A)	■Option -D	■Option -D	■Option -D
■Use:Using multiple switching power supplies, single-phase inverter, etc	■Use:Using multiple switching power supplies, single-phase inverter, robot with servo motor, medical equipment, etc	■Use:A case when using multiple switching power supplies, or for medical applications like endoscope, etc	■Use:A case when using multiple switching power supplies, or for medical applications like endoscope, etc	■Use:A case when using multiple switching power supplies, or for medical applications like endoscope, etc	■Use:A case when using multiple switching power supplies, or for medical applications like endoscope, etc

1 Noise Basics

- 1 What Is Noise?
- 2 Noise Sources
- 3 What Is EMC?
- 4 Propagation Paths of Noise
 - a. Conductive noise
 - b. Inductive noise
 - c. Radiated noise
- 5 Basics of Noise Reduction
- 6 Types of Conductive Noise
- 7 Types of and Countermeasures for Noise
 - a. High-frequency noise
 - b. Pulse noise
 - c. Surge noise

2 Selection of EMI Filters

- 1 Rated Voltage
- 2 Rated Current
- 3 Test Voltage (Withstand Voltage)
- 4 Insulation Resistance (Isolation Resistance)
- 5 Leakage Current
- 6 DC Resistance
- 7 Temperature/Humidity
- 8 Circuitry
 - a. Single-phase one-stage filter
 - b. Single-phase two-stage filter
- 9 Safety Standards
 - a. Overview of safety standards
 - b. Safety standards for EMI filters
 - c. CCC approval from China
- 10 Attenuation Characteristic (Static Characteristic)
- 11 Pulse Attenuation Characteristic
- 12 Ground Capacitor Codes
- 13 Options
 - a. DIN rail installation type
 - b. Terminal block type
 - c. High permeability choke coil type
 - d. Hexagon socket head cap bolt type
 - e. With switch of line to ground capacitor type
 - f. Improve differential mode attenuation type
 - g. Ultra high attenuation type for EU
 - h. High input voltage type

3 How to Use EMI Filters

- 1 Ground Wiring
- 2 Input and Output Wiring

4 Noise Reduction

- 1 Input and Output Impedance and Filter Circuit
- 2 EMI Filter Installation and Orientation
- 3 Combining Multiple EMI Filters
- 4 External Ferrite Core

5 EMC Test

- 1 CE Marking
 - a. Machinery directive
 - b. EMC directive
 - c. Low voltage directive
- 2 Conducted Emission
- 3 Radiated Emission
- 4 Power Supply Harmonic Current
- 5 Electrostatic Discharge
- 6 Radio frequency electromagnetic field
- 7 Fast Transient/Burst
- 8 Surge
- 9 Conducted Radio-frequency Interference
- 10 Power Frequency Magnetic Field
- 11 Voltage Dip/Momentary Power Interruption
- 12 Unit of Noise
- 13 Detection Method
 - a. Peak detection
 - b. Quasi-peak detection
 - c. Average detection
- 14 Noise Terminal Voltages, Radiated Emission Limits (Extractions)
- 15 Terminology related to EMC Test

6 Supplement

- 1 Source Voltages in the World

1 What Is Noise?

Noises refers to unwanted variations or fluctuations in voltage, current, signals, etc.

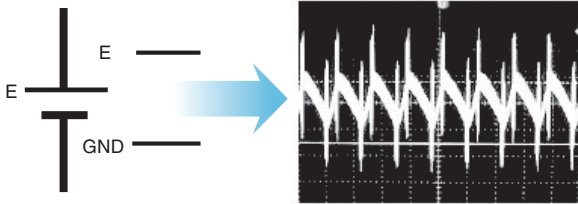

What a designer expects (an ideal steady voltage source)

In reality, noises are included.

Figure 1.1.1 What Is Noise?

2 Noise Sources

Noise comes in two types: natural noise and manmade noise. While natural noises are generated by a lightning strike or static electricity, manmade noises are generated by familiar devices such as industrial equipment, fluorescent bulbs, or communication equipment.

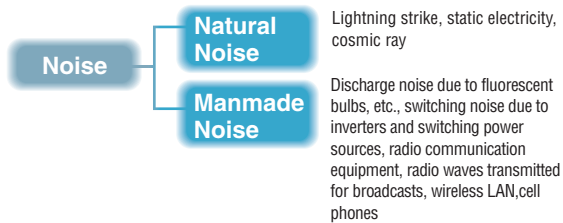

Figure 1.2.1 Noise Sources

Typical devices that generate noise are switching power sources and general-purpose inverters. Such devices include switching elements such as FETs and IGBTs, and are major noise sources due to high-frequency switching of those elements.

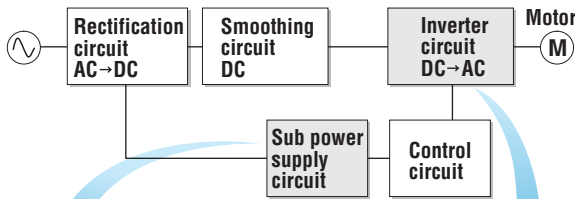

Figure 1.2.2 Inverter block diagram

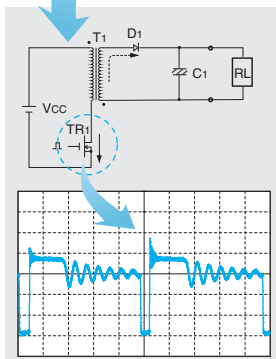

Figure 1.2.3 Sub power supply inverter operation waveform

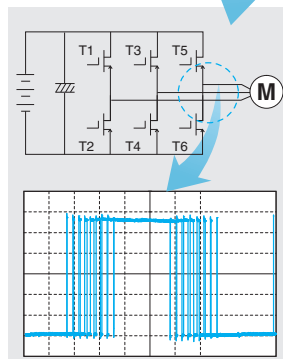

Figure 1.2.4 Inverter PWM output waveform

3 What Is EMC?

EMC stands for electromagnetic compatibility, and refers to the ability of electrical equipment to have both EMI and EMS at once; the former indicates the ability to suppress noise radiated from the equipment itself and the latter means the ability to endure noise from other equipment.

What are EMC compliant products?

The EMC compliant products refer to those that meet standards required by EMI and EMS.

They provide various types of parts that can deal with noise from the viewpoint of EMI and/or EMS.

Our noise filters (hereinafter, “EMI filters”) are parts that mainly deal with conducted interference in terms of EMI.

EMC = EMI + EMS

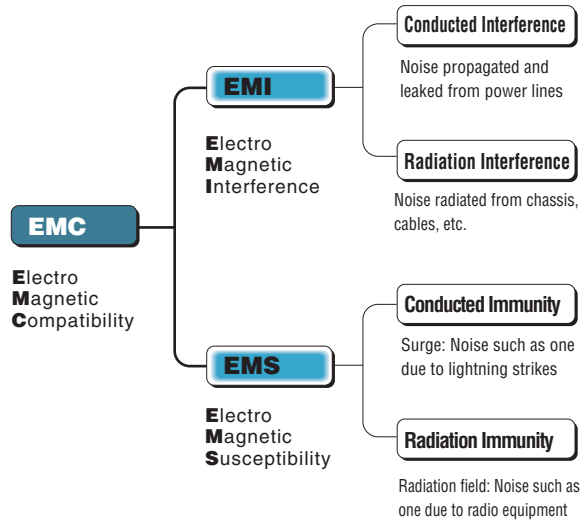

Figure 1.3.1 Concept of EMC

4 Propagation Paths of Noise

a. Conductive noise

Refers to noise that propagates through a power line or PCB tracing.

b. Inductive noise

Refers to noise that is induced due to electromagnetic or electrostatic induction caused by a power line or a signal line of a peripheral device when it is placed near a line or pattern in which noise current flows and propagates through the line.

c. Radiated noise

Noise radiated by an antenna (or a line be having as an antenna) that propagates to other devices through the air.

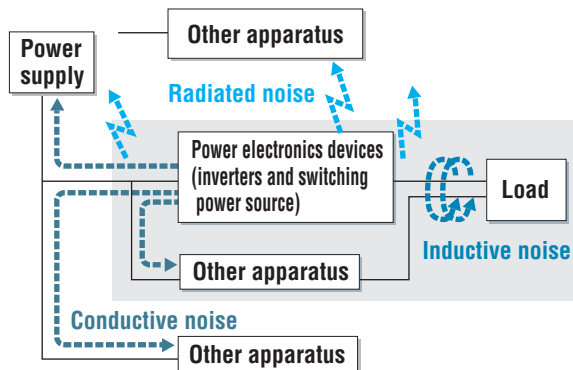

Figure 1.4.1 Propagation Paths of Noise

5 Basics of Noise Reduction

The propagation of noise consists of a noise source, an entity that is affected by the noise, and propagation path that connects both. To reduce noise:

- Reduce the noise level of a noise source
- Make it more difficult for noise to propagate
- Make equipment less vulnerable to noise

In addition to the above, designs must consider standards, quality and cost of noise reduction methods.

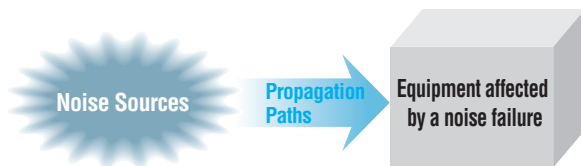

Figure 1.5.1 Overview of Noise Generation and Propagation Path

6 Types of Conductive Noise

Noise is divided into two types based on its generation mode: normal mode noise and common mode noise. Normal mode noise is also called differential mode noise, and refers to noise generated between power lines. Common mode noise refers to noise generated between a power line and ground line.

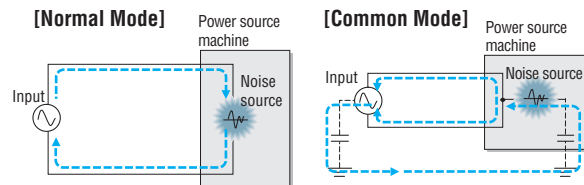
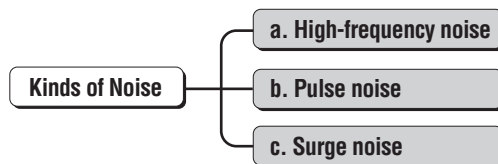

Figure 1.6.1 Noise Generation Paths
(Example in which a noise source is within power equipment)

7 Types of and Countermeasures for Noise



a. High-frequency noise

Also called EMI noise or power supply noise and refers to high-frequency components such as the clock frequency of a computer and switching frequency of power sources. As an antinoise measure, an EMI filter should be installed on the input side. An appropriate filter should be selected based on requirements such as attenuation, mechanical design and cost.

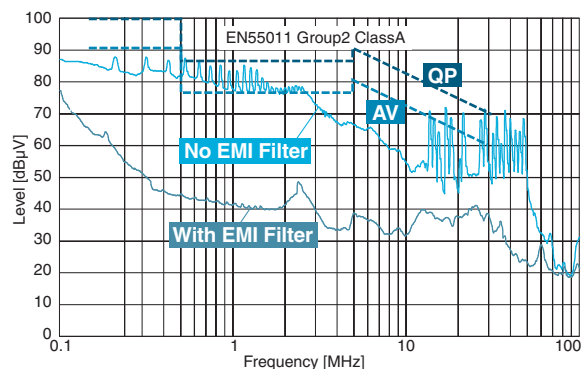
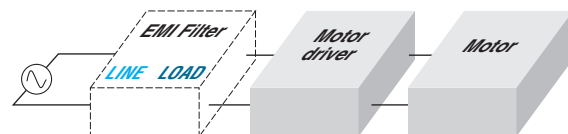

Figure 1.7.1 Example of Noise Reduction by an EMI Filter

1 Noise Basics

Output ripple noise from a switching power source is also a type of high-frequency noise.

Ripple noise can be reduced with a DC filter designed for it.

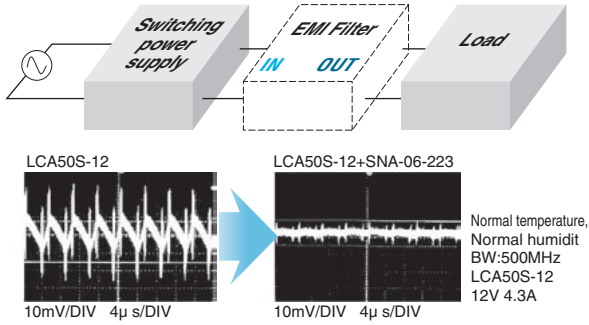

Figure 1.7.2 Example of Effectiveness of Ripple Noise Filter

b. Pulse noise

This noise is generated when a relay or motor is driven. As peak voltage may reach as high as a few thousand volts, generic filters may not be able to sufficiently attenuate noise because its choke coil gets saturated. As an antinoise measure, one could select a filter that uses an amorphous core for its superior pulse attenuation characteristic.

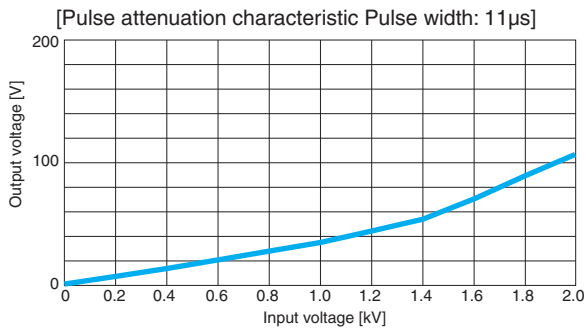
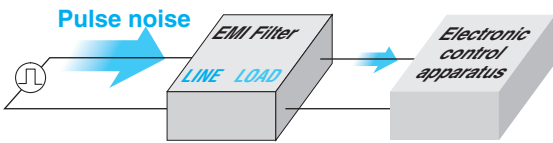

Figure 1.7.3 Example of Pulse Attenuation Characteristic(NAP-16-472)

c. Surge noise

This noise occurs when a natural discharge (such as lightning) affects a power line. As the generated voltage reaches as extremely high as a few kilovolts or more, EMI filters cannot suppress surge noise. As an antinoise measure, one could use a part such as a varistor to control surge voltage between power lines or between a power line and ground. EMI filters can withstand approximately 2 kV between power lines and approximately 4 kV between a power line and ground (these values are not guaranteed).

If surges are a concern, surge countermeasures should be selected and installed to handle the EMI filter's capabilities.

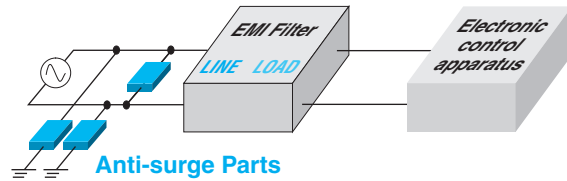

Figure 1.7.4 Proper Installation Location of surge Countermeasures

1 Rated Voltage

The rated voltage is the maximum line voltage (nominal value) allowable to be used.

As the rated voltages for some parts used within an EMI filter are high in reality, however, voltages higher than the rated voltage of the EMI filter may be used without causing any trouble.

In fact, the rated voltages of filter components are often higher, in which case the filter can handle actual voltages that exceed its ratings.

In the case of some EMI filters, the maximum operation voltages are defined by specifications for them, separately from rated voltages.

Note that using EMI filters at voltages lower than their rated voltages do not pose any problems. For example, an EMI filter with a rated voltage of AC 250 V can be used for power lines of AC 100V.

As for line frequency, EMI filters for AC power supply lines have been basically designed to be used with the commercial frequency (50 Hz/60 Hz).

Higher frequencies such as 400Hz can cause problems such as excessive capacitor heating.

Note that EMI filters for AC power lines can also be used for DC power supply lines.

2 Rated Current

The rated current is the maximum load current (nominal value) that can be continuously carried. If the ambient temperature is high, however, the load current needs to be derated.

Figure 2.2.1 shows an example of a derating characteristic.

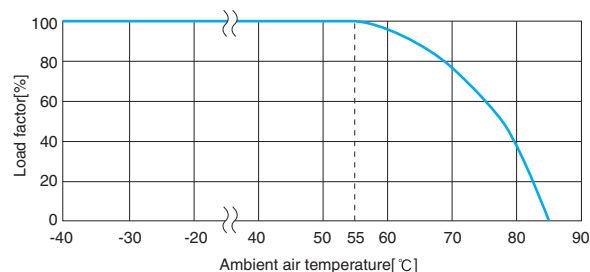

Figure 2.2.1 Derating Curve

This example indicates that when the maximum ambient temperature reaches 75, the EMI filter should be used with a load factor of approximately 60% (approximately 60% of the rated current) or lower.

Current higher than the rated current would be allowed to flow in EMI filters for a short period of time only. Inrush current (Up to 40A or 10 times the rated current, single shots with a length of a few milliseconds) from devices such as a general switching power source does not cause any problems, but relatively long and / or repetitive peak current draws can result in the average current exceeding the filter's rating.

3 Test Voltage (Withstand Voltage)

The test voltage is a voltage value that is applied at the time of withstand voltage test. The withstand voltage test is to verify that the part does not break when applying a high voltage in a short period of time between a terminal (line) and the mounting plate (ground) of an EMI filter.

In the case of EMI filters for AC power lines, the test voltage is generally AC 2000 V or AC 2500 V.

In withstand voltage tests, the high voltage applied between a line and ground, results in abnormally high leakage current flow. When carrying out a withstand voltage test in an acceptance inspection, please set the cutoff current of withstand voltage test equipment to an appropriate value (the cutoff current defined in the specifications for the EMI filter).

For some EMI filters that have ground capacitors with extremely large capacity, DC voltages may be used for test voltages because the leakage current becomes too high when AC voltages are applied.

4 Insulation Resistance (Isolation Resistance)

Insulation resistance is a resistance value when applying a specified DC voltage (normally 500 V) between isolated conductors such as a terminal (line) and the mounting plate (ground), and regarded as one indicator of degree of insulation.

The insulation resistance is found by measuring the very small current that flows in an insulating material such as a resin case and capacitor when DC voltage is applied.

5 Leakage Current

The leakage current is an electric current that flows from the ground terminal of an EMI filter when the filter is connected to an AC power line.

Generally, as one sets the capacitance of a ground capacitor to a higher value, the reduction effect on common mode noise will be heightened and at the same time, the leakage current will increase.

Care must be taken, because large leakage current could cause a circuit breaker to trip or electric shock to occur when the EMI filter is not properly grounded.

Current (I) that flows from each power line to ground is represented with the following expression; it forms the basis of leakage current calculation.

$$I = 2 \pi f C E$$

f : Power frequency
 C : Capacitance between line and ground
 E : Power supply voltage between line and ground

2 Selection of EMI Filters

6 DC Resistance

DC resistance is a resistance value between the input and output of an EMI filter (the sum of resistance values for both directions).

It is mostly accounted for with the coil resistances but also includes connections between the coils and terminals.

The voltage drop caused by an EMI filter is represented with the following expression:

$$\text{Voltage drop} = \text{DC resistance} \times \text{Load current}$$

Note that specifications for some products define voltage drops when rated current is carried, instead of resistance values.

7 Temperature/Humidity

a. Operating temperature

This is the range of ambient temperatures for which the product's usage is guaranteed.

If an ambient temperature is high, the load current needs to be derated.

b. Operating humidity

This is the range of ambient humidities for which the product's usage is guaranteed.

It assumes no condensation.

c. Storage temperature and humidity

The specified ranges of ambient temperatures and humidities that EMI filters in an unenergized state can be stored without deteriorating performance. No condensation is assumed for the storage humidity.

8 Circuitry

The following represents examples of EMI filter circuit structures.

a. Single-phase 1-stage filter

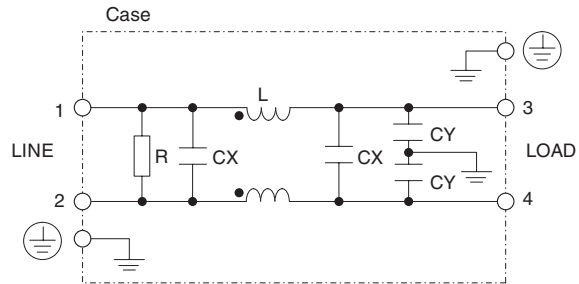

Figure 2.8.1 Circuit Structure Example of a Single-phase 1-stage EMI Filter

This figure shows a standard circuit structure for single-phase EMI filters.

L and CYs reduce the common mode noise; CXs and leakage inductance from L reduce the normal mode noise.

R indicates a discharge resistance for capacitors.

b. Single-phase 2-stage EMI filter

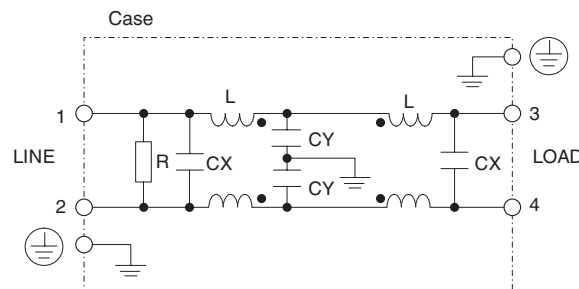

Figure 2.8.2 Circuit Structure Example of a Single-phase 2-stage EMI filter

The above figure represents a circuit structure example of placing choke coils in two stages to improve the attenuation characteristic.

The following graph shows an example comparison of attenuation characteristics for a 1-stage and 2-stage EMI filter.

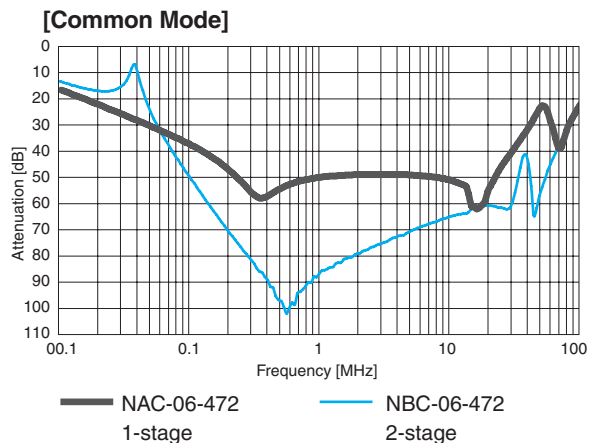

Figure 2.8.3 Example of Comparing Attenuation Characteristics between 1-stage and 2-stage EMI filters.

2 Selection of EMI Filters

9 Safety Standards

a. General description of safety standards

The international standards consist of IEC standards which concern the electrical fields, and ISO standards which concern the non-electrical fields.

IEC

(International Electrotechnical Commission)

Standardization organization for standards related to the electrical fields; its headquarters is located in Switzerland.

It releases technical standards for electricity based on the latest sciences and technologies, and each country develops its own specific safety standards based on the corresponding IEC standards.

CISPR

(Comite International Special des

Perturbations Radioelectriques

=International Special Committee
on Radio Interference)

One of IEC's special committees; it was established with the aim to integrate standards such as allowable values and measurement methods for interfering waves causing radio communication failures, and includes a standardization committee for EMC (Electro Magnetic Compatibility).





European Standard / EN Standard

(Europäische Norm=European Standard)

The EN Standard was created based on the IEC and CISPR standards, and consists of items almost similar to those in both standards.

A unique number is assigned to each standard. (Example: IEC939 EN60939)

[An example of Certification Authorities in Europe based on EN Standard]

VDE	Germany	
TUV	Germany	
DEMKO	Denmark	
SEMKO	Sweden	

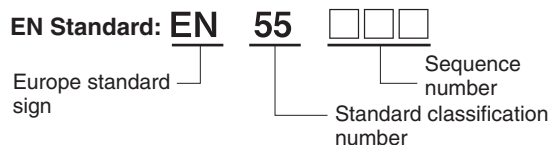

Standard classification number	Reference standards
EN50000 series	General European standards
EN55000 series	CISPR standards
EN60000 series	IEC standards

ENEC



(European Norm Electrical Certification)

The safety approval mark in Europe that enables products to smoothly be delivered among all the EU signatories, EFTA (European Free Trade Area), and East European countries.

Electronic products that are authorized to bear the ENEC mark do not need to be subjected to application procedures among the signatories. It provides a benefit of eliminating the need to obtain approval from each signatory to which they are distributed. The ENEC mark is intended to apply to products such as lighting equipment, transformers, information processing equipment, switches and EMI filters.

★ EU signatories... Germany, UK, Italy, Denmark, and 24 other countries

★ EFTA... Iceland, Norway, Switzerland, and Lichtenstein

★ East European... Ukraine, Estonia, Belorussia, Moldova, Latvia, and Lithuania

North America

UL (Underwriters Laboratories Inc.)

A test organization established in 1894 by the Electrical Bureau of the National Board of Fire Underwriters. Since then, it has been performing compliance tests on various electric products.

CSA (Canadian Standard Association)

A non-profit standardization organization established in Canada in 1919. Each state law in Canada requires that electric equipment that needs to be connected to a public power source conforms to the CSA standards.

UL	USA	
CSA	Canada	

As the US and Canada have signed MRA (Mutual Recognition Agreement), mutual approval can be obtained. If UL verifies that a certain electric product conforms to the CSA standard, or to the UL and CAS standards, the product is authorized to bear the following approval marks:

CSA	
UL, CSA	

b. Safety standards for EMI filters

Different products may conform to different safety standards and bear different approval marks (for use in different countries). Check the approved safety standards when considering purchasing them.

IEC939	International standard	IEC
EN60939	EU	EN
UL1283	USA	UL
C22.2 No.8	Canada	CSA

c. CCC approval from China

EMI filters do not fall within the scope of CCC. (as of November 2011)

2 Selection of EMI Filters

10 Attenuation Characteristic (Static Characteristic)

Attenuation characteristic provides a rough indication of noise reduction effect. The graph is derived from plotting an attenuation characteristic when connecting a EMI filter to a specified measurement circuit with frequency on the horizontal axis and with attenuation on the vertical axis.

The measurement methods are shown in Figure 2.10.1 and Figure 2.10.2. The attenuation is given as the ratio of U_{01} to U_{02} , where U_{01} is output when EMI filters are not in the measured circuit and U_{02} is when an EMI filter is in the circuit, and normally expressed with the logarithm of that ratio in [dB].

$$\text{Attenuation} = 20\text{Log}_{10} (U_{01}/U_{02}) \text{ [dB]}$$

U_{01} : Generated voltage when a EMI filter is not inserted [V]

U_{02} : Generated voltage when a EMI filter is inserted [V]

*An attenuation of 20 [dB] means that the noise level reduces to 1/10 of the one without an EMI filter. Similarly, 40 [dB] and 60 [dB] mean a 1/100 and 1/1000 reduction of the noise level, respectively.

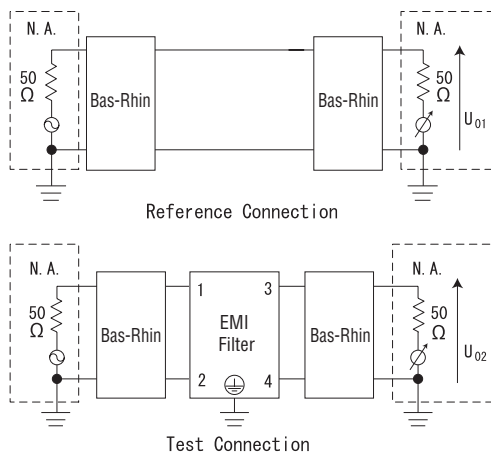

Figure 2.10.1 Attenuation Characteristic Measurement Method (Single-phase Normal Mode)

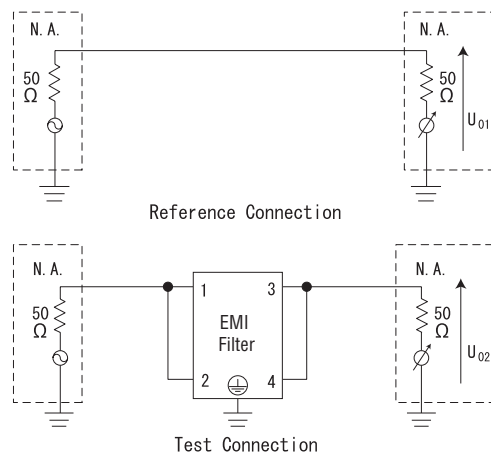

Figure 2.10.2 Attenuation Characteristic Measurement Method (Single-phase Common Mode)

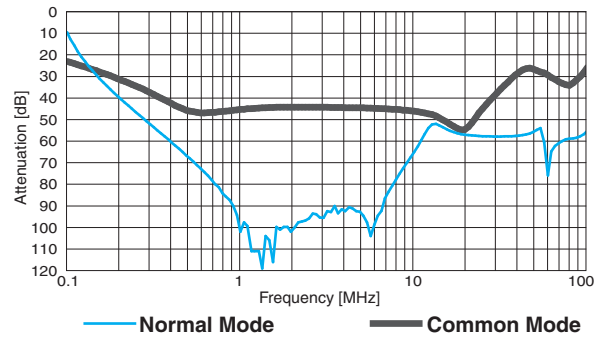

Figure 2.10.3 Example of Attenuation Characteristic (NAC-16-472)

The attenuation characteristic of EMI filters is affected by the input and output impedances of a measured circuit. This attenuation characteristic (static characteristic) is measured under the constant condition of input and output impedances of 50 Ω regardless of measurement frequencies. This enables the attenuation characteristics of different filters to be compared under the same conditions.

However, actual electronic devices have different power line impedances, and impedance itself has its own frequency characteristic and does not take a constant value.

For these reasons, the attenuation characteristics (static characteristics) that are specified in the catalogs for EMI filters do not necessarily coincide with those when they are attached to actual electronic devices.

One must also be careful that when connecting EMI filters in series, the static characteristic of the resultant series is not derived from simply adding the static characteristics [dB] of the individual filters.

11 Pulse Attenuation Characteristic

Figure 2.11.2 represents how much the EMI filter can attenuate pulse common mode noises, which may cause malfunctions of electronic equipment, connected to a power line. Figure 2.11.1 illustrates the measurement method.

When terminating the input and output of the EMI filter with 50 Ω , and applying a specified pulse waveform on the input, pulse voltages appearing on the output are measured and plotted with the horizontal axis representing input pulse voltage and with the vertical axis representing output pulse voltage.

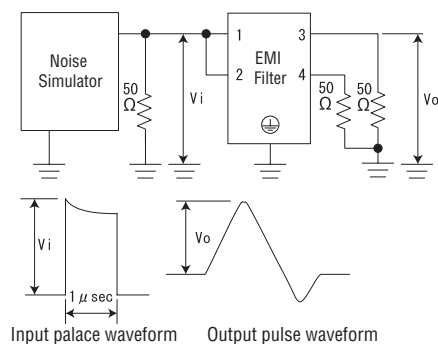

Figure 2.11.1 Measurement Method for Pulse Attenuation Characteristic (Single Phase)

2 Selection of EMI Filters

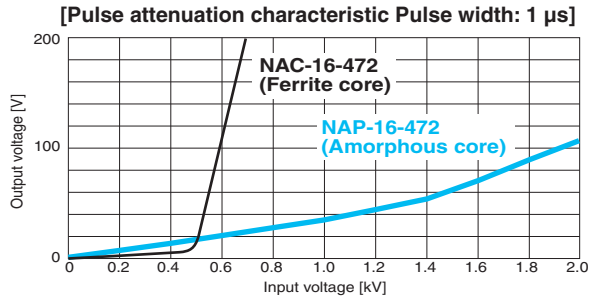

Figure 2.11.2 Example of Comparing Pulse Attenuation Characteristics

Figure 2.11.2 gives an example of comparing pulse attenuation characteristics for an EMI filter using a general ferrite core and one using an amorphous core.

The graph suggests that the amorphous core prevents the voltage of output pulses from increasing quickly in relation to rising input pulse voltage (a good pulse attenuation characteristic).

Beyond a given volt-time product the choke coil of an EMI filter will saturate, resulting in significantly reduced noise suppression. The volt-time product (V·T) that causes the core to reach magnetic saturation is found with the following calculation expression:

$$V \cdot T = \Delta B \cdot N \cdot Ae$$

V : Pulse voltage [V]
T : Pulse width [sec]
 ΔB : Change of core's magnetic flux density = $B_m - B_r$ [T]
 (B_m : Saturation magnetic flux density
 B_r : Residual magnetic flux density)
N : Number of turns in a coil [turns]
Ae : Effective cross section [m²]

According to the expression, an EMI filter using a core that has larger ΔB (for example, an amorphous core) is less vulnerable to magnetic saturation, assuming that the numbers of turns and the sizes of cores are the same.

12 Ground Capacitor Codes

Many EMI filters can support various capacities of ground capacitors by specifying an appropriate code. The selectable ground capacitor codes depend on the types of EMI filters; the following table lists an example of ground capacitor codes and attenuation characteristics.

Table 2.12.1 Example of Ground Capacitor Codes (EAP series)

Code	Leak Current (input 125/250V 60Hz)	Line to ground capacitor (nominal value)
000	5 μA / 10 μA max	Not Provided
101	12.5 μA / 25 μA max	100pF
221	25 μA / 50 μA max	220pF
331	37.5 μA / 75 μA max	330pF
471	50 μA / 100 μA max	470pF
681	75.5 μA / 150 μA max	680pF
102	0.13 mA / 0.25 mA max	1000pF
222	0.25 mA / 0.5 mA max	2200pF
332	0.38 mA / 0.75 mA max	3300pF
472	0.5 mA / 1.0 mA max	4700pF

EAP -10 -472 -□
 Model Name | Rated Current | Ground Capacitor Codes | Option

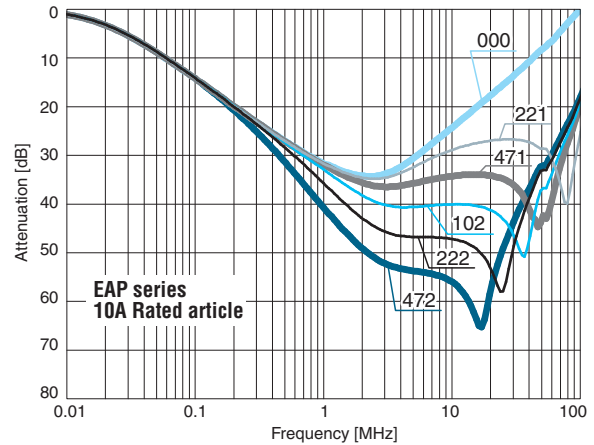

Figure 2.12.1 Example of Ground Capacitor Codes and Common Attenuation Characteristics

Generally, the larger capacity one sets a ground capacitor to, the better the common mode attenuation characteristic. But, the leakage current will also become larger, which means that there is a tradeoff.

The abundant selections of ground capacitor capacities make it possible for one to develop the best balance between attenuation characteristic and leakage current.

13 Options

Our EMI filters can be customized by specifying an option code.

As the types of set options depend on filter products, please refer to our catalog.

The following describes the outline of each option:

a. DIN rail installation type: D

This type of EMI filter can be installed to a DIN rail often used for control consoles, etc.

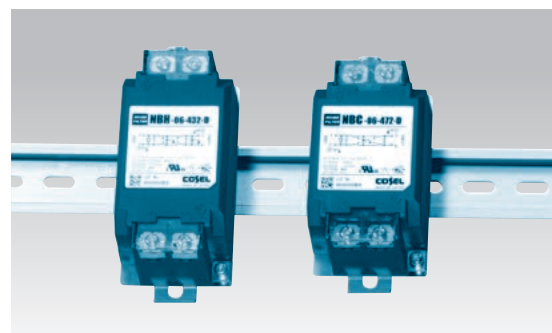

Figure 2.13.1 Examples of DIN Rail Installation Type EMI Filters

Note that as this type of EMI filter may not produce proper noise attenuation with grounding through a DIN rail, one must connect the ground to the protective earth terminal (PE) of the EMI filter. For EMI filters that have two protective earth terminals, it can connect the ground to either one only.

2 Selection of EMI Filters

b. Terminal block type: T

These types of EMI filters use a terminal block as their interface (if the standard product uses a connector).

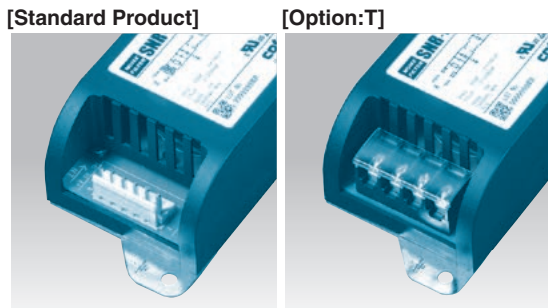

Figure 2.13.2 Comparison between Standard Product and T-option Product

c. High permeability choke coil type (ultra low-frequency and ultra high attenuation): H

These types of EMI filters the choke coil core with a high permeability core. These types improve the common mode attenuation characteristic for low frequencies compared to their standard products.

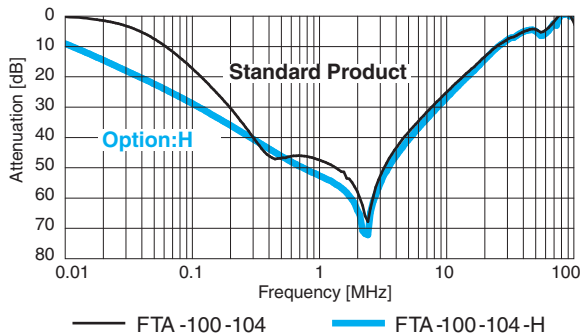

Figure 2.13.3 Example of Comparing Common Mode Attenuation Characteristics between Standard Product and H-option Product

d. Hexagon socket head cap bolt type: S

These types of EMI filters have a hexagon socket head cap (Allen) bolt in their terminal block in instead of the standard bolt (cross recessed (Philips) hexagon head bolt). Customers can select the desired type of bolt for tools they are using.

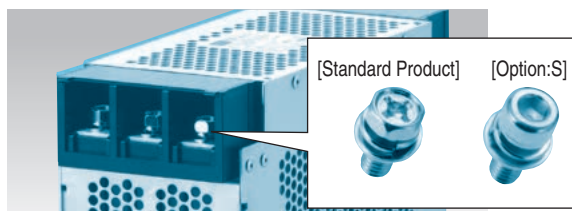

Figure 2.13.4 Comparison between Standard Product and S-option Product

e. With switch of line to ground capacitor type : G

These types of Ultra high attenuation type for EU, With switch of line to ground capacitor.

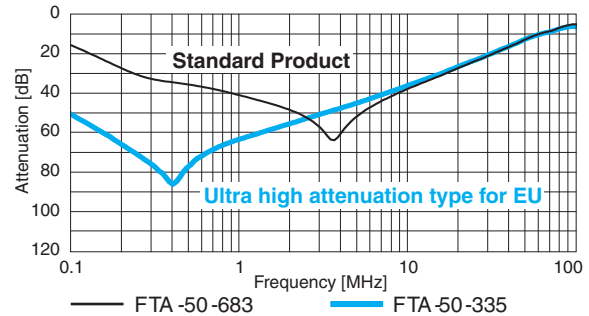

Figure 2.13.5 Example of Comparing Common Mode Attenuation Characteristics between Standard Product and Ultra high attenuation type for EU Product



Figure 2.13.6 With switch of line to ground capacitor type (Customers use when Test Voltage)

f. Improve differential mode attenuation type : U

These types of change the rated voltage 250V.

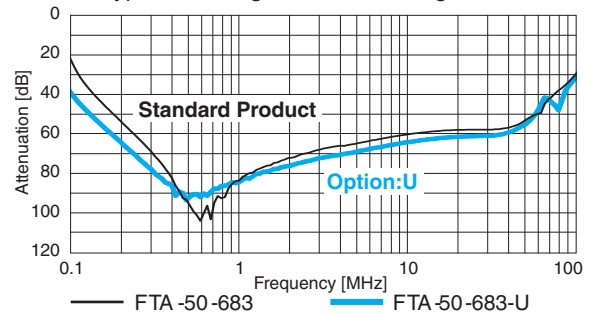

Figure 2.13.7 Example of Comparing differential Mode Attenuation Characteristics between Standard Product and U-option Product

g. Ultra high attenuation type for EU : L

These types of Ultra high attenuation type for EU.

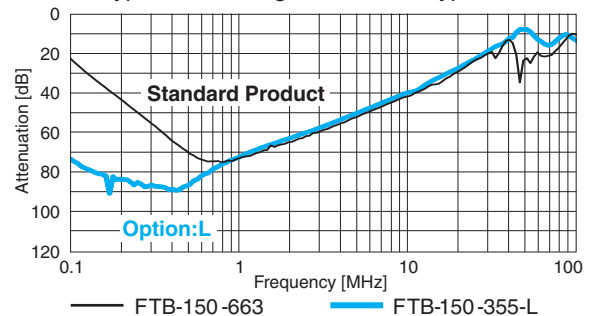

Figure 2.13.8 Example of Comparing Common Mode Attenuation Characteristics between Standard Product and L-option Product

h. High input voltage : F

These types of change the rated voltage 500VAC/600VDC.

Option code is possible combination. Please contact us for more information.

3 How to Use EMI Filters

1 Ground Wiring

When wiring an EMI filter with a ground wire, use a wire as thick and short as possible. A long ground wire will deteriorate attenuation of high frequencies due to inductance in the wire.

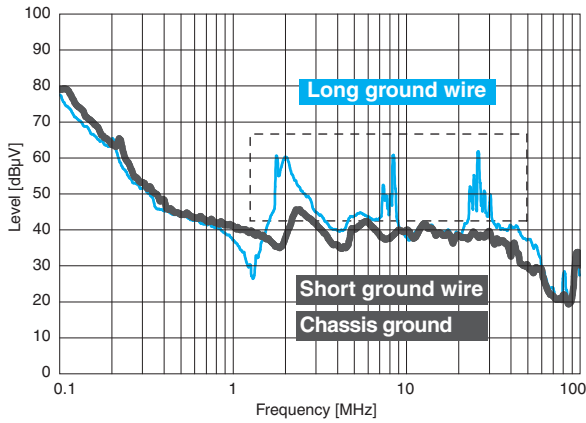

Figure 3.1.1 Example of Ground wiring Effed on Noise

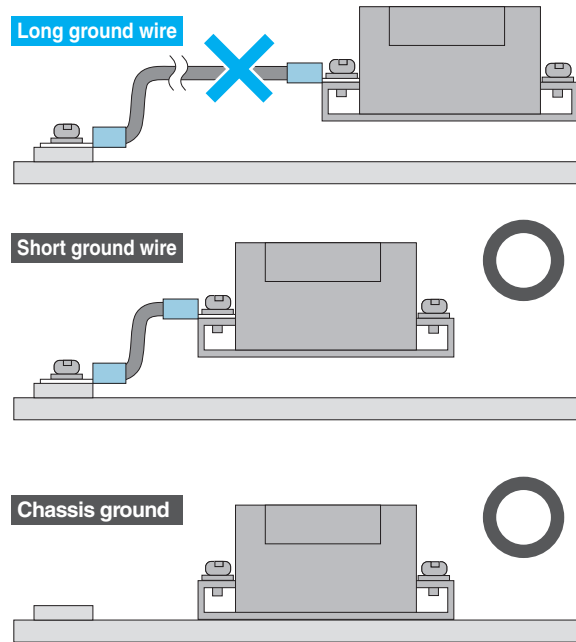

Figure 3.1.2 Proper grounding

If customers connect the metal chassis of their EMI filter, they can obtain an effect similar to a short ground wire.

2 Input and Output Wiring

Separate input wires from output wires. If one binds input and output wires of EMI filters, or lays them close to each other, the filters may lose their proper attenuation effect because the high-frequency noise component may bypass them. Twisting input (and / or output) wires in pairs can reduce noise.

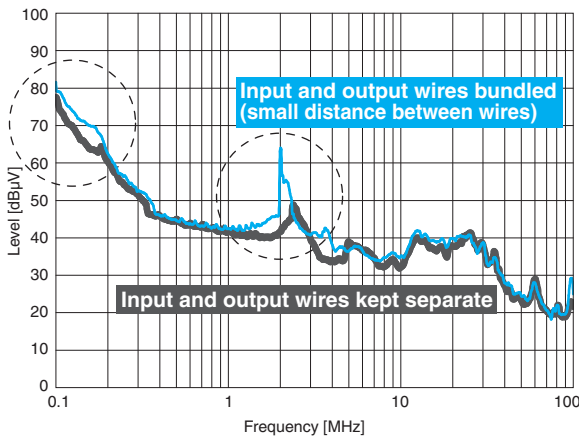

Figure 3.2.1 Example of Effect of wiring on Noise

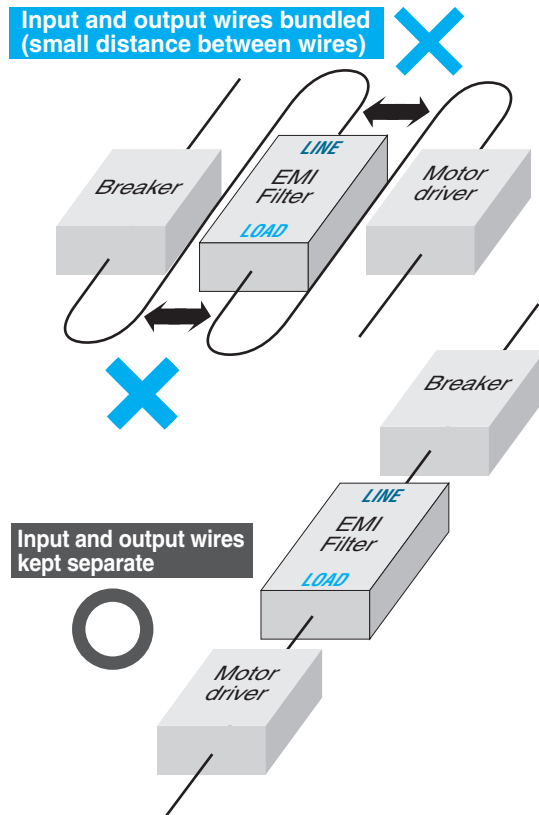

Figure 3.2.2 Input and output wires

4 Noise Reduction

1 Input and Output Impedance and Filter Circuit

The input/output impedances of a noise source and a load will have various optimal filter circuits. General EMI filters take a configuration of a low pass filter that combines L and C. If the expected attenuation effect can not be obtained, impedances of noise source and load may be the reasons.

Table 4.1.1 Combinations of I/O Impedances and Optimal Filters

		Output impedance (Z_o)	
		High	Low
Input impedance (Z_i)	High		
	Low		

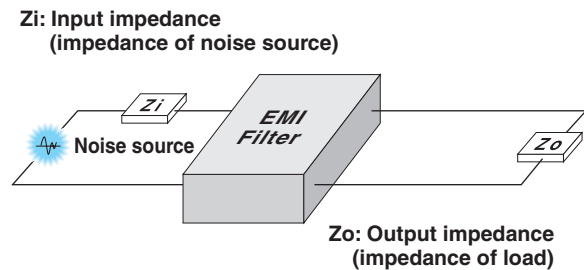

Figure 4.1.1 Input/output Impedances of an EMI Filter Circuit

2 EMI Filter Installation and Orientation

Generally, an EMI filter is placed in a way that the LINE terminal is connected to the input side, but it can also be used in a reverse configuration.

However, it may end up producing a different attenuation effect.

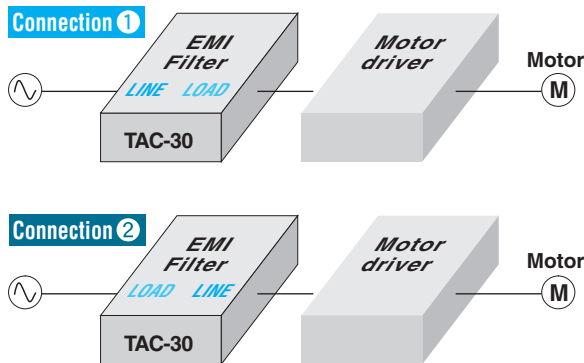

Figure 4.2.1 Direction in which an EMI Filter Is Attached and Connected

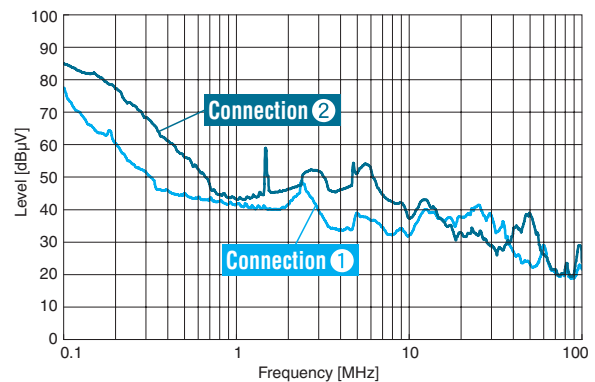

Figure 4.2.2 Example of Effect of Filter Orientation on Noise

If the internal circuit consists of a symmetric EMI filter (one of the NBC series or TBC series), the direction in which the filter is connected will not cause any difference in noise attenuation. But in the case of asymmetric ones, it may cause difference in the attenuation.

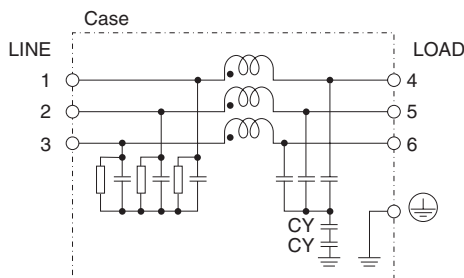

Figure 4.2.3 TAC Series Circuit Diagram (Circuit Is Asymmetric)

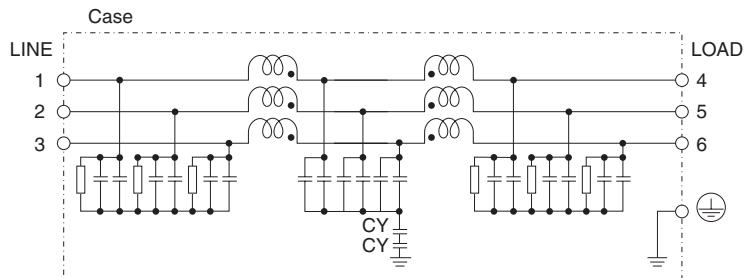

Figure 4.2.4 TBC Series Circuit Diagram (Circuit Is Symmetric)

CY: Line to ground capacitor
 : Mounting Plate

3 Combining Multiple EMI Filters

If one EMI filter cannot provide sufficient attenuation, the attenuation effect can be improved by connecting two filters in series. However, one must pay attention to the fact that it will result in combining the leakage current and voltage drop of two EMI filters.

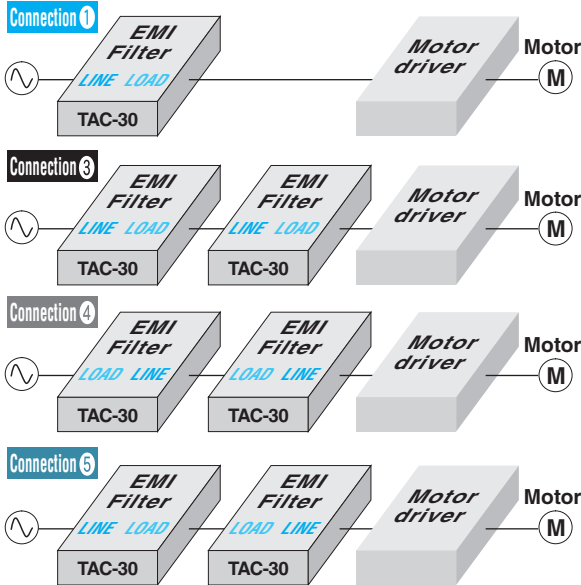

Figure 4.3.1 Example of EMI Filter Connection Directions

When connecting two EMI filters, the direction in which they are connected may also cause difference in the attenuation characteristic. Figure 4.3.3 shows the results of comparing the attenuation characteristics (static characteristics) due to different directions in which two EMI filters are connected.

Figure 4.3.4 shows the actual sample noise characteristics caused by the connection directions.

Unlike the static characteristic data, connection 4 does not improve the attenuation in this case. This phenomenon occurred because the input and output impedances of the EMI filters were different from the conditions of static characteristics.

When trying to optimize the way EMI filters are connected, one must evaluate by checking actual noise levels.

4 External Ferrite Core

If one EMI filter cannot provide sufficient attenuation, the effect can be improved by inserting an external core.

Whether a core is inserted on the LINE side or on the LOAD side of an EMI filter may cause difference in the attenuation characteristic.

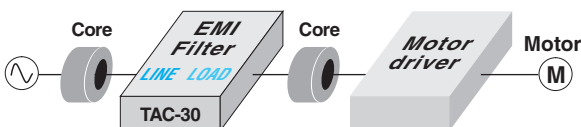

Figure 4.4.1 Example of Placing an External Core

When adding a core on the LINE side, one needs a core that can generate sufficiently large inductance for the choke coil within the EMI filter.

Just inserting on the LINE side a core whose performance is equal to or less than that of the internal choke coil does not contribute to reducing noise.

When inserting it on the LOAD side, it will produce a large attenuation effect because the circuit takes a configuration of a T-type EMI filter circuit.

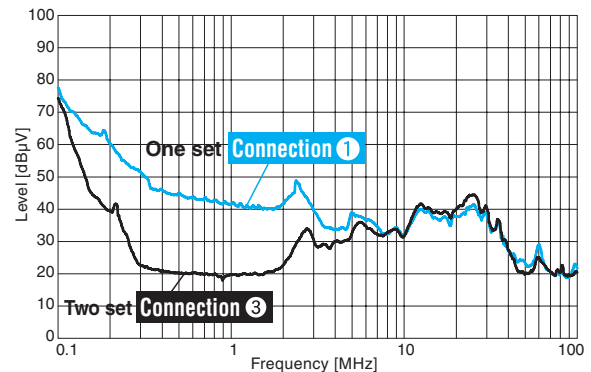

Figure 4.3.2 Example of Effect of Combining Multiple Filters

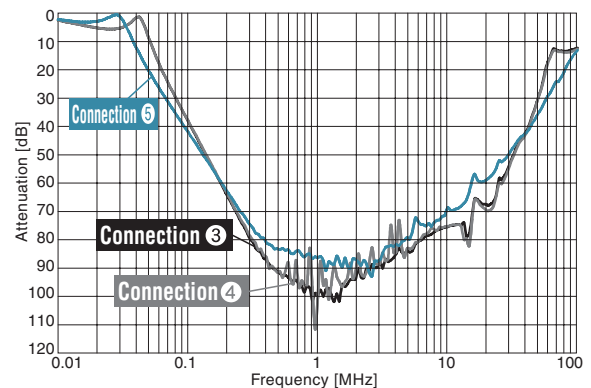

Figure 4.3.3 Comparing Static Characteristics of Different 2-filter configurations

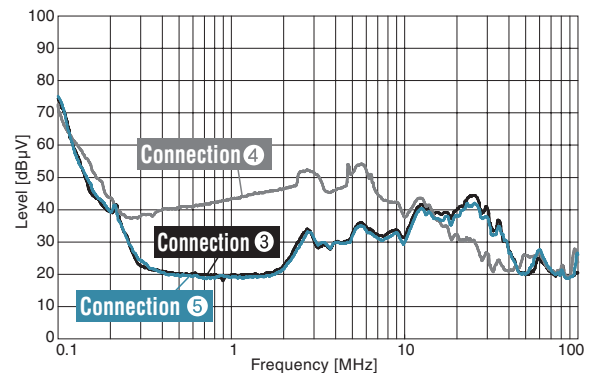

Figure 4.3.4 Comparing Effects of Different 2-filter Configurations

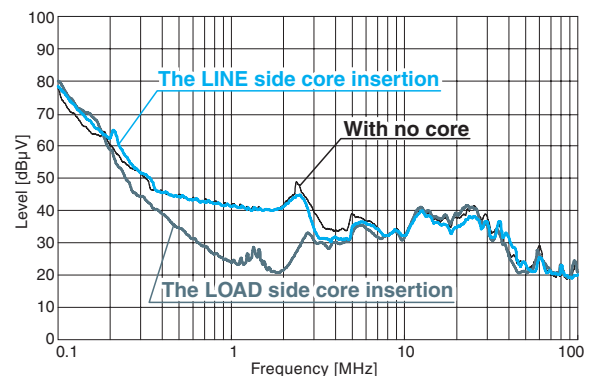

Figure 4.4.2 Example of Effect of Adding an External Ferrite Core

1 CE Marking

For machines and electric products to be sold in the EU area, manufacturers are required to bear a CE mark to prove they are in compliance with safety requirements, quality control, and ecocide prevention. To be allowed to do so, they must meet appropriate EC directives. The following describes the EC directives that are applied to general machinery products:

a. Machinery directive

This directive covers products that are an assembly of parts and have a driving section (with the central focus on industrial equipment).

b. EMC directive

This directive is intended to apply to electric parts which can be sources of radio disturbance or are affected by electromagnetic interference. It requires that two items, emission (EMI) and immunity (EMS), be met.

c. Low voltage directive

This directive is intended to apply to products that operate with a rated voltage in the range of 50 to 1000 V AC or 75 to 1500 V DC.

As there are no appropriate EC directives (including the ones described above) which apply to EMI filters, EMI filter products cannot bear a CE mark.

However, EMI filters can obtain an ENEC mark, which has a similar effect on bypassing application procedures of its signatories.

2 Conducted Emission EN61000-6-4

The voltages of interfering waves propagated through a power cable from equipment to the outside are measured with LISN in an open site or anechoic chamber.

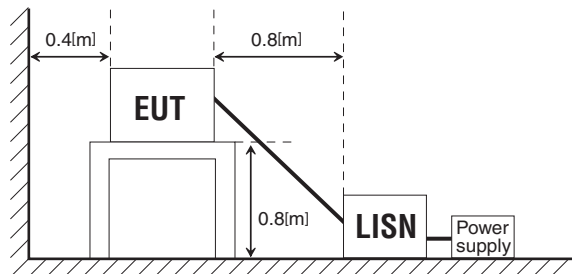

Figure 5.2.1 Example of Conducted Emissions Measurement Configuration

★ : Refer to the description in "Terminology related to EMC Test" in this document.

3 Radiated Emission EN61000-6-4

When operating equipment, the strength of electromagnetic waves is measured in a range of specified frequencies at a location 3 or 10 m away from the equipment

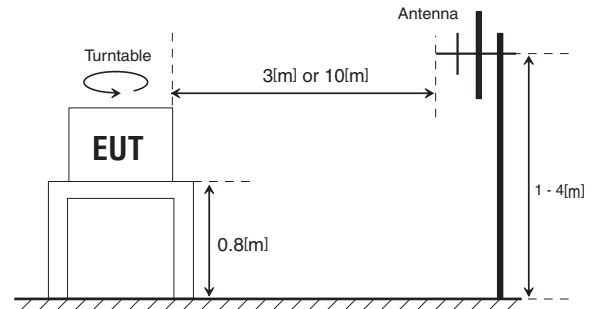

Figure 5.3.1 Example of Radiated Emission Measurement Configuration

4 Power Supply Harmonic Current EN61000-3-2

One analyzes the frequencies of input currents and checks the value of the harmonic current for each order.

5 Electrostatic Discharge EN61000-4-2

This test simulates effects of electrostatic discharge (malfunctions or destruction of semiconductor elements) and includes contact discharge and aerial discharge in its scope.

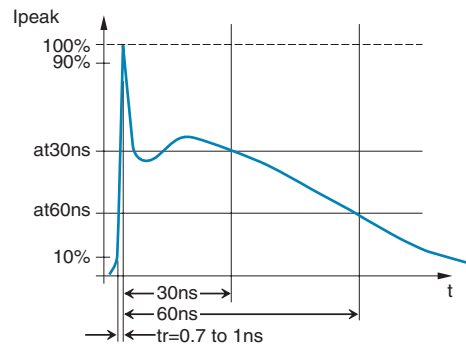

Figure 5.5.1 Discharge current waveform

Table 5.5.1 Application Level

Level	Specified voltage	First peak discharge current ($\pm 10\%$) I_p	Rise time	Current value at 30 ns ($\pm 30\%$)	Current value at 60 ns ($\pm 30\%$)
1	2kV	7.5A	0.7 - 1ns	4A	2A
2	4kV	15A	0.7 - 1ns	8A	4A
3	6kV	22.5A	0.7 - 1ns	12A	6A
4	8kV	30A	0.7 - 1ns	16A	8A

6 Radio frequency electromagnetic field EN61000-4-3

This test checks immunities of equipment to effects of electromagnetic waves.

7 Fast Transient/Burst EN61000-4-4

This test checks immunities to burst waves by from injecting via cable pulses that resemble the results of a discharge.

8 Surge EN61000-4-5

This test checks immunities to surges by applying a specified surge waveform.

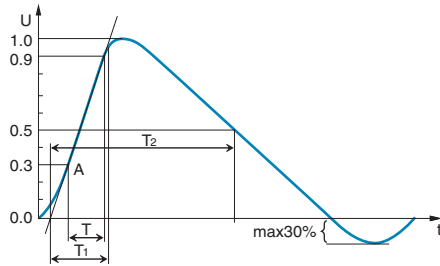

Figure 5.8.1 Example of a Surge Waveform in Voltage

Table 5.8.1 Level

Level	Open circuit test voltage±10% [kV]
1	0.5
2	1.0
3	2.0
4	4.0
X	special

9 Conducted Radio-frequency Interference EN61000-4-6

This test checks immunities to conducted disturbances when electromagnetic waves pass into equipment through a cable.

10 Power Frequency Magnetic Field EN61000-4-8

This test checks immunities to magnetic fields generated by power frequency currents flowing through an input line or a power wiring.

11 Voltage Dip/Momentary Power Interruption EN61000-4-11

These tests check if equipment functions normally after momentary voltage drop, or power failure that decreases voltage to 0.

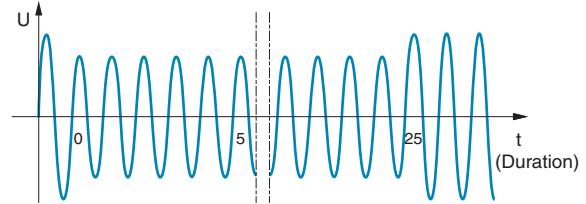

Figure 5.11.1 Example of a Waveform of Voltage Dips

12 Unit of Noise

Noise is represented with 1 [μV] as its reference in [dB]. It is assumed that 1 [μV] equals 0 [dBμV]. For example, 1 [V] is represented as follows:

$$20\text{Log}_{10} \frac{1}{1 \times 10^{-6}} = 120 \text{ [dB}\mu\text{V]}$$

$$\begin{aligned} 10 \text{ [V]} &\Rightarrow 140 \text{ [dB}\mu\text{V]} \\ 100 \text{ [V]} &\Rightarrow 160 \text{ [dB}\mu\text{V]} \\ 1000 \text{ [V]} &\Rightarrow 180 \text{ [dB}\mu\text{V]} \end{aligned}$$

13 Detection Method

a. Peak detection (PK)

It detects the heights of peaks of an output waveform.

b. Quasi-peak detection (QP)

It detects quasi-peaks through a circuit that has time constants at the time of charge and discharge. Quasi-peak detection value equals an intermediate value between peak and average ones.

This detection has high measurement results when noise has a long duration or occurs frequently.

c. Average detection (AV)

It detects an average of values of an output waveform.

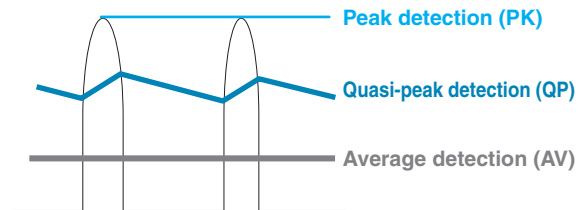

Figure 5.13.1 Relations between Detection Methods and Measurement Levels

14 Conducted and Radiated Emission Limits (Excerpt)

Test item	Standard	EN61000-6-3	EN61000-6-4	EN55011			EN55022		EN60601-1-2			EN50370-1	
	Classification	Common standard	Common standard	Group 1 ★			Standard for product groups		Standard for product groups			Standard for product groups	
	Product	-	-	ISM equipment ★			Information processing equipment (ITE equipment)		ISM equipment (medical equipment)			Machine tool	
				-	20 kVA or less	Exceeding 20 kVA			-	20 kVA or less	Exceeding 20 kVA	16A or less	Exceeding 16A
	Operating environment	Class B	Class A	Class B	Class A	Class B	Class A	Class B	Class A	Class B	Class A	Class A	

Level:Unit [dB μ V]

Conducted emission	Limit	QP	0.1 - 50.5MHz	66 - 56	79	66 - 56	79	100	66 - 56	79	66 - 56	79	100	79	100		
			0.5 - 5MHz	56	73	56	73	86	56	73	56	73	56	73	86	73	86
			5 - 30MHz	60	73	60	73	90 - 73	60	73	60	73	60	73	90 - 73	60	90 - 70
		AV	0.15 - 0.5MHz	56 - 46	66	56 - 46	66	90	56 - 46	66	56 - 46	66	56 - 46	66	90	66	90
			0.5 - 5MHz	46	60	46	60	76	46	60	46	60	46	60	76	60	76
			5 - 30MHz	50	60	50	60	80 - 60	50	60	50	60	50	60	80 - 60	60	80 - 60

Level:Unit [dB μ V/m]

Radiated emission	Limit	10m Law	30 - 230MHz	30	40	30	40	50	30	40	30	40	50	40	50		
			230MHz - 1GHz	37	47	37	47	50	37	47	37	47	37	47	50	47	50
		30m Law	30 - 230MHz	-	30	-	-	-	-	-	-	-	-	-	-	-	-
			230MHz - 1GHz	-	37	-	-	-	-	-	-	-	-	-	-	-	-

★ : Refer to the description in "Terminology related to EMC Test" in this document.

(As of November 2011)

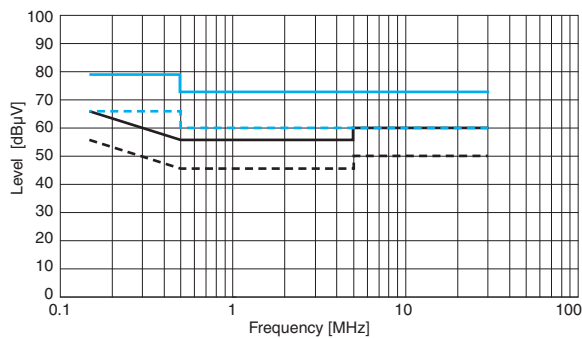

— EN55011 ClassA QP (Group 1)
 - - - EN55011 ClassA AV (Group 1)
 — EN55011 ClassB QP (Group 1)
 - - - EN55011 ClassB AV (Group 1)
 (the above is also applied to EN55013, EN55014-1, EN55022, and EN60601-1)

Figure 5.14.1 Conducted Emission Limit Graph

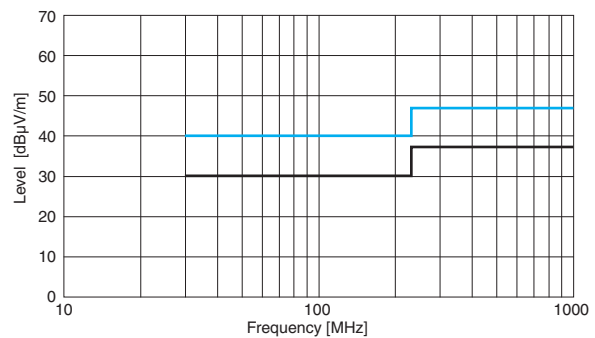

Figure 5.14.2 Radiated Emission Limit Graph

15 Terminology related to EMC Test**★ EUT**

Stands for Equipment Under Test, and refers to equipment that will be tested or provided for a test.

★ Immunity test

Refers to a test to evaluate the durability of EUT against electromagnetic interference.

★ Emission test

Refers to a test to evaluate whether the strength of electromagnetic interference emitted from EUT exceeds a given limit.

★ Open site

Refers to an experimental facility installed outdoors to be used for activities such as EMC measurement.

★ Anechoic chamber

Refers to a facility to be used to create an electromagnetically isolated environment; the interior surfaces of the chamber absorb radio frequency waves.

★ CISPR

One of IEC's special committees; it was established to integrate standards such as those for allowable values and measurement methods for interfering waves causing radio communication failures and includes a standardization committee for EMC (Electro Magnetic Compatibility).

★ Group 1 and Group 2 in EN55011

Group1 : Equipment for laboratories, healthcare, and sciences (Example: frequency counters, spectrum analyzers, switching power source, and measuring apparatus)

Group2 : Industrial induction heating equipment, induction heating equipment, industrial microwave heating equipment, household microwave ovens, medical equipment, spark erosion equipment, and spot welders.

























★ ISM equipment

Stands for Industrial, Scientific and Medical radio-frequency equipment and refers to radio-frequency equipment for industry, science, and health care.

★ LISN

Stands for Line Impedance Stabilization Network. It refers to equipment that sends noise components to a measurement device while monitoring impedances, looking at the power source from EUT. It is also called AMN (Artificial Mains Network).

1 Source Voltages in the World

	People's Republic of China	Single phase 2 wire 220V	Three phase 4 wire 380V
	Taiwan	Single phase 2 wire 110V, 220V	Three phase 4 wire 380V
	India	Single phase 2 wire 230V, 240V	Three phase 4 wire 400V, 415V
	Indonesia	Single phase 2 wire 220V	Three phase 4 wire 380V
	Japan	Single phase 2 wire 100V, 200V	Three phase 3 wire 200V
	Korea	Single phase 2 wire 110V, 220V	Three phase 3 wire 200V Three phase 4 wire 380V
	Philippines	Single phase 2 wire 220V, 230V, 240V	Three phase 3 wire 480V
	Singapore	Single phase 2 wire 230V	Three phase 4 wire 400V
	Thailand	Single phase 2 wire 220V	Three phase 4 wire 380V
	Malaysia	Single phase 2 wire 240V	Three phase 4 wire 415V
	Egypt	Single phase 2 wire 220V	Three phase 4 wire 380V
	Saudi Arabia	Single phase 2 wire 127V, 220V	Three phase 4 wire 380V
	Australia	Single phase 2 wire 240V	Three phase 4 wire 415V
	New Zealand	Single phase 2 wire 230V, 240V	Three phase 4 wire 400V, 415V
	Austria	Single phase 2 wire 230V	Three phase 4 wire 400V
	France	Single phase 2 wire 230V	Three phase 4 wire 400V
	Germany	Single phase 2 wire 230V	Three phase 4 wire 400V
	UK	Single phase 2 wire 240V	Three phase 4 wire 415V
	Netherlands	Single phase 2 wire 230V	Three phase 4 wire 400V
	Italy	Single phase 2 wire 220V	Three phase 4 wire 380V
	Spain	Single phase 2 wire 127V, 220V	Three phase 4 wire 380V
	Switzerland	Single phase 2 wire 230V	Three phase 4 wire 400V
	Russia (former republics of the Soviet Union)	Single phase 2 wire 127V, 220V	Three phase 4 wire 380V
	USA	Single phase 2 wire 120V, 265V, 277V Single phase 3 wire 115/230V, 120/240V, 240/480V	Three phase 4 wire 208V, 460V, 480V
	Brazil	Single phase 2 wire 127V	Three phase 4 wire 220V

EAC/EAM/EAP series

EAC -10 -472 -□

① ② ③ ④

- ① Series Name
- ② Rated Current
- ③ Line to ground capacitor code: Refer to table 1.1.

table 1.1 Line to ground capacitor code

Code	EAC	EAM	EAP	Leakage Current (Input 125/250V 60Hz)	Line to ground capacitor (nominal value)
000	●	●	●	5 μ A / 10 μ A max	Not Provided
101	●	●	●	12.5 μ A / 25 μ A max	100pF
221	●	●	●	25 μ A / 50 μ A max	220pF
331	●	●	●	37.5 μ A / 75 μ A max	330pF
471	●	●	●	50 μ A / 100 μ A max	470pF
681	●	●	●	75.5 μ A / 150 μ A max	680pF
102	●	●	●	0.13mA / 0.25mA max	1,000pF
222	●	●	●	0.25mA / 0.5 mA max	2,200pF
332	●	●	●	0.38mA / 0.75mA max	3,300pF
472	●	●	●	0.5 mA / 1.0 mA max	4,700pF

*When the line to ground capacitor code is different, the attenuation characteristic is different.

- ④ Option
- D: DIN rail installation type

* The dimensions change when the option is set. Refer to External view.

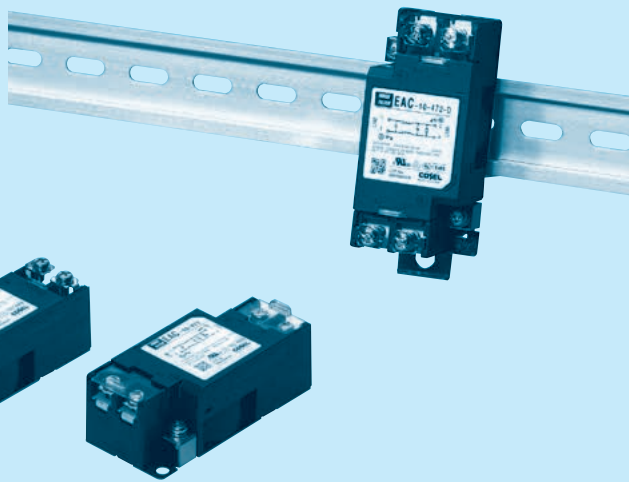

The terminal cover is retracted inside the unit

DIN rail installation type is option

Features of EAC/EAM/EAP series

- Single Phase 250VAC (1-Stage filter)
 - Small size
 - Quick and easy push-down terminal
- Just connect the wires, push-down and tighten the screws with a screwdriver

■ EAC: Attenuation type from 150kHz to 1MHz

■ EAM: Low leakage current type

■ EAP: Outside impulse attenuation type

Specifications

No.	Items	EAC-03-472	EAC-06-472	EAC-10-472	EAC-16-472	EAC-20-472	EAC-30-472
		EAM-03-000	EAM-06-000	EAM-10-000	EAM-16-000	EAM-20-000	EAM-30-000
		EAP-03-472	EAP-06-472	EAP-10-472	EAP-16-472	EAP-20-472	EAP-30-472
1	Rated Voltage[V]	AC 1 ϕ 250 / DC250					
2	Rated Current[A]	3	6	10	16	20	30
3	Test Voltage (Terminal-Mounting Plate)	2,500 VAC (Cutoff Current = 20mA), 1minute at room temperature and humidity					
4	Isolation Resistance (Terminal-Mounting Plate)	500 VDC 500M Ω min at room temperature and humidity					
5	Leakage current	Refer to table 1.1					
6	DC resistance	180m Ω max	110m Ω max	40m Ω max	20m Ω max	10m Ω max	6m Ω max
7	Safety agency approval temperatures	-25 to +85°C (Refer to Derating Curve)					
8	Operating temperature	-40 to +85°C (Refer to Derating Curve)					
9	Operating humidity	20 to 95%RH (Non condensing)					
10	Storage temperature/humidity	-40 to +85°C/20 to 95%RH (Non condensing)					
11	Vibration	10 to 55Hz, 19.6m/s ² (2G), 3min. Period, 1hour each X, Y and Z axis					
12	Impact	196.1m/s ² (20G), 11ms Once each X, Y and Z axis					
13	Safety agency approvals	UL1283, CSA C22.2 No.8 (C-UL), DIN EN60939 VDE0565 Teil3-1, ENEC (At only AC input)					
14	Case size (without projection) /Weight	39 X 30 X 85 mm [1.54 X 1.18 X 3.35 inches] (W X H X D) /170g max (Option : -D refer to external view)					

Circuit Diagram

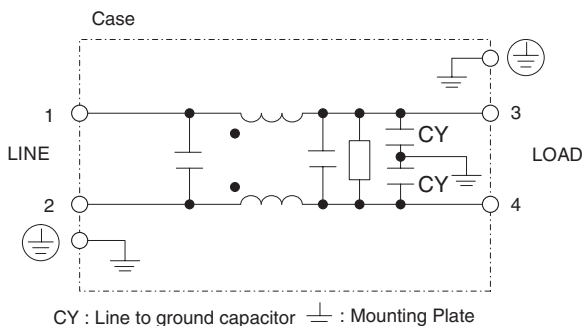

Derating Curve

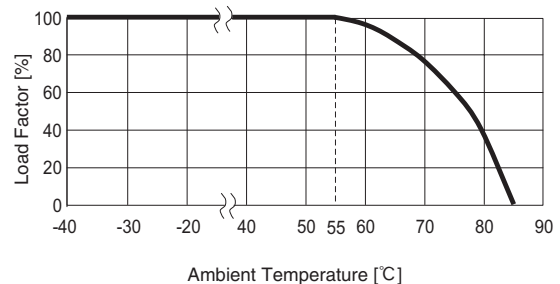

External view

This product is shipped in the following condition, because it is equipped with push-down terminals.

- ① The terminal cover is retracted inside the unit.
- ② The screws for connecting the terminals are held in the up right position.

Standard Type

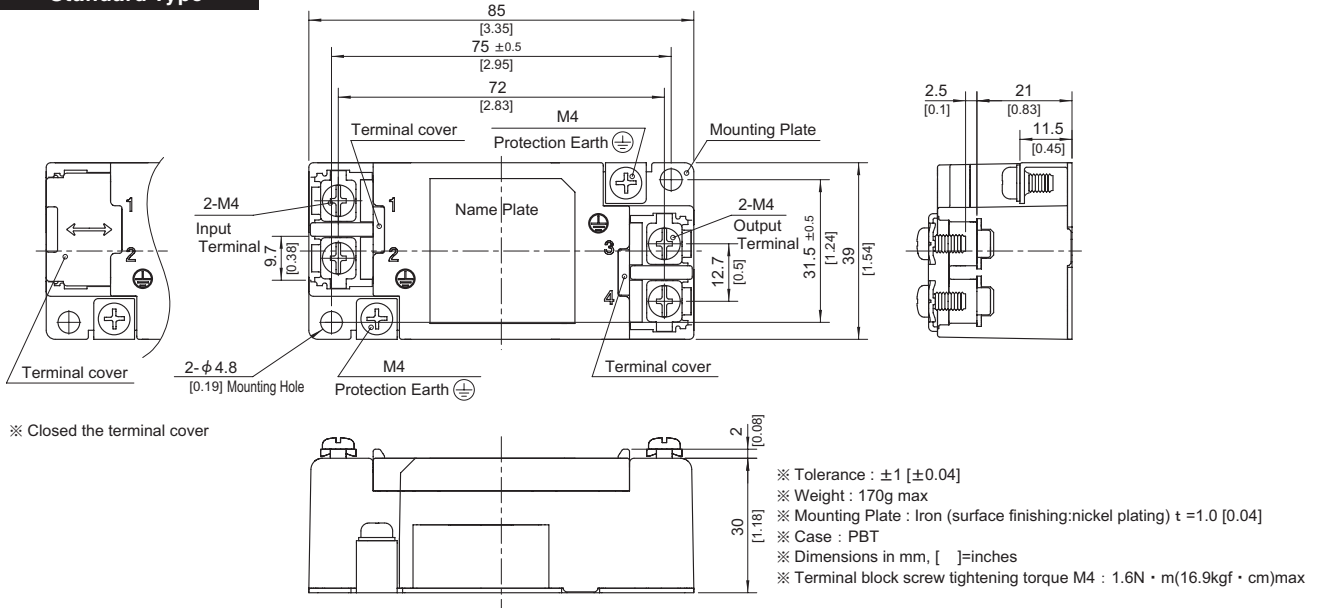

DIN rail installation Type

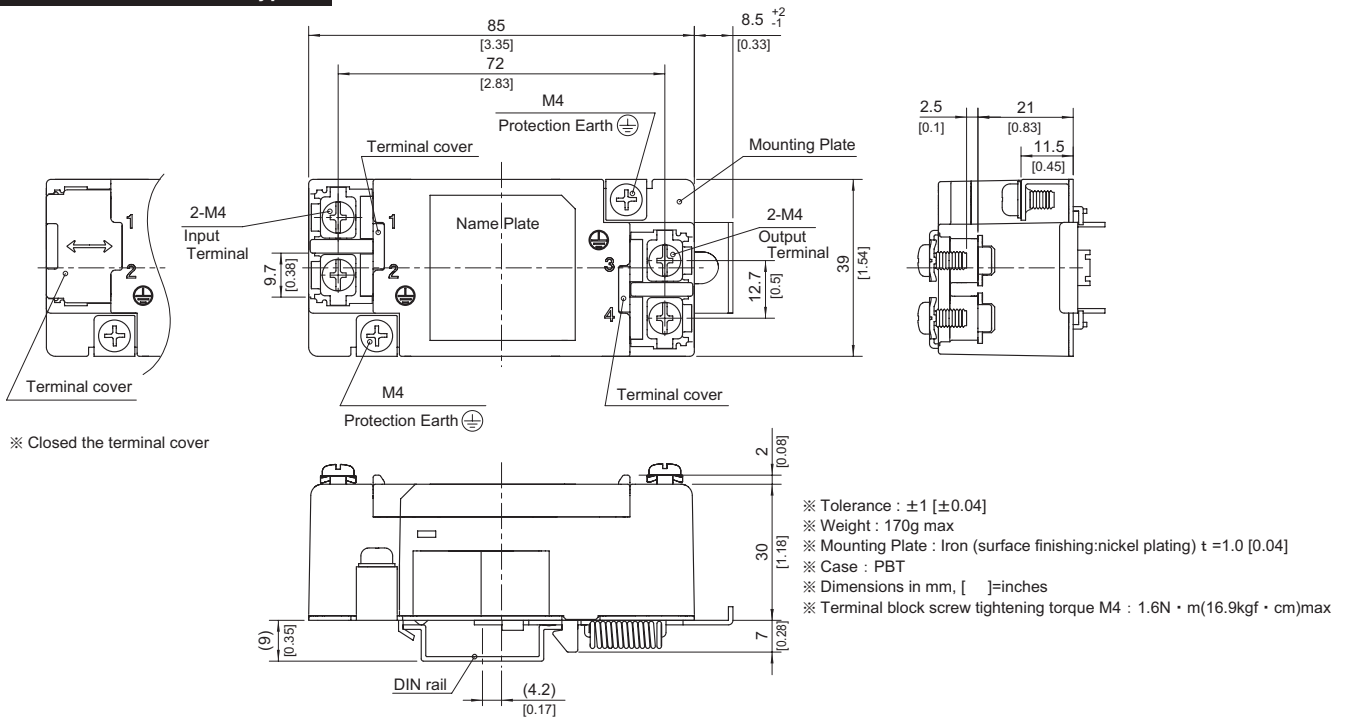

■ Note when installing the EMI/EMC Filter on a DIN rail.

When the EMI/EMC Filter is grounded through the DIN rail, the proper noise attenuation may not be achieved.

Be sure to connect the protection earth (PE) of the EMI/EMC Filter body to the earth. At least one PE connection is required.

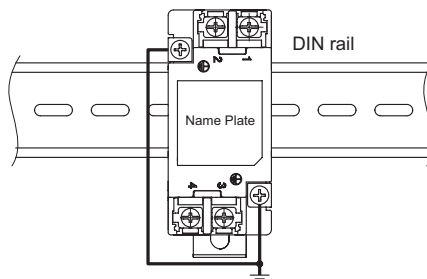

ESC/ESM/ESP series

ESC -10 -472 -□

① ② ③ ④

- ① Series Name
- ② Rated Current
- ③ Line to ground capacitor code: Refer to table 1.1.

table 1.1 Line to ground capacitor code

Code	E S C	E S M	E S P	Leakage Current (Input 125/250V 60Hz)	Line to ground capacitor (nominal value)
000	●	●	●	5 μ A / 10 μ A max	Not Provided
101	●	●	●	12.5 μ A / 25 μ A max	100pF
221	●	●	●	25 μ A / 50 μ A max	220pF
331	●	●	●	37.5 μ A / 75 μ A max	330pF
471	●	●	●	50 μ A / 100 μ A max	470pF
681	●	●	●	75.5 μ A / 150 μ A max	680pF
102	●	●	●	0.13 mA / 0.25mA max	1,000pF
222	●	●	●	0.25 mA / 0.5 mA max	2,200pF
332	●	●	●	0.38 mA / 0.75mA max	3,300pF
472	●	●	●	0.5 mA / 1.0 mA max	4,700pF

* When the line to ground capacitor code is different, the attenuation characteristic is different.

- ④ Option
- D: DIN rail installation type

* The dimensions change when the option is set. Refer to External view.

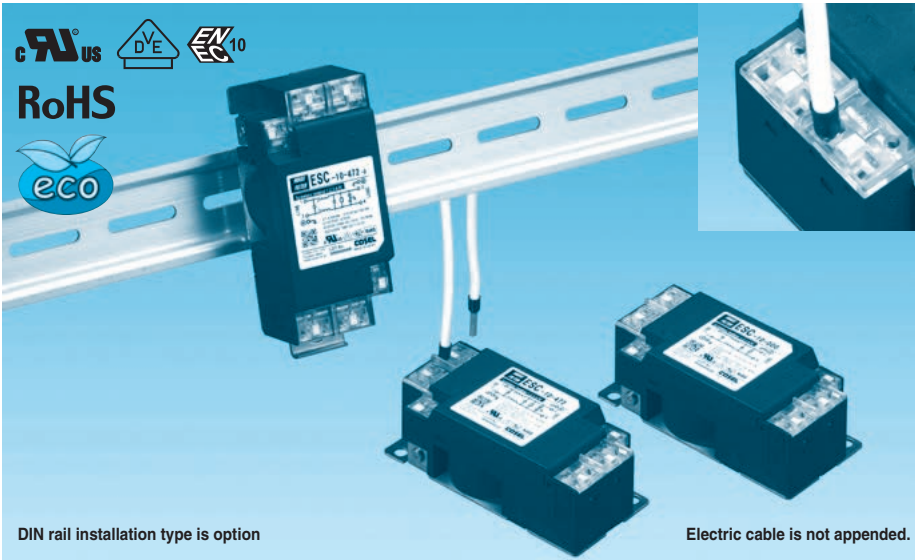

Features of ESC/ESM/ESP series

- Single Phase 250VAC (1-Stage filter)
- Small EMI/EMC Filters that change input-output terminal and protection earth terminal of EA series into screwless terminal type
- Torque management is unnecessary with screwless

■ ESC : Attenuation type from 150kHz to 1MHz

■ ESM : Low leakage current type

■ ESP : Outside impulse attenuation type

Specifications

No.	Items	ESC-03-472	ESC-06-472	ESC-10-472	ESC-16-472
		ESM-03-000	ESM-06-000	ESM-10-000	ESM-16-000
		ESP-03-472	ESP-06-472	ESP-10-472	ESP-16-472
1	Rated Voltage[V]	AC 1 ϕ 250 / DC250			
2	Rated Current[A]	3	6	10	16
3	Test Voltage (Terminal-Mounting Plate)	2,500 VAC (Cutoff Current = 20mA), 1minute at room temperature and humidity			
4	Isolation Resistance (Terminal-Mounting Plate)	500 VDC 500M Ω min at room temperature and humidity			
5	Leakage current	Refer to table 1.1			
6	DC resistance	180m Ω max	110m Ω max	40m Ω max	20m Ω max
7	Safety agency approval temperatures	-25 to +85 $^{\circ}$ C (Refer to Derating Curve)			
8	Operating temperature	-40 to +85 $^{\circ}$ C (Refer to Derating Curve)			
9	Operating humidity	20 to 95%RH (Non condensing)			
10	Storage temperature/humidity	-40 to +85 $^{\circ}$ C/20 to 95%RH (Non condensing)			
11	Vibration	10 to 55Hz, 19.6m/s 2 (2G), 3min. Period, 1hour each X, Y and Z axis			
12	Impact	196.1m/s 2 (20G), 11ms Once each X, Y and Z axis			
13	Safety agency approvals	UL1283, CSA C22.2 No.8 (C-UL), DIN EN60939 VDE0565 Teil3-1, ENEC (At only AC input)			
14	Case size (without projection) /Weight	39X30X85 mm [1.54X1.18X3.35 inches] (W X H X D) /170g max (Option : -D refer to external view)			

Circuit Diagram

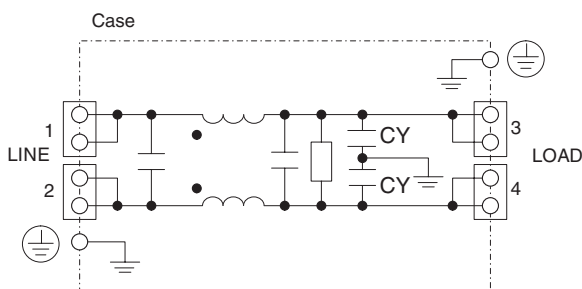

CY : Line to ground capacitor \perp : Mounting Plate

Derating Curve

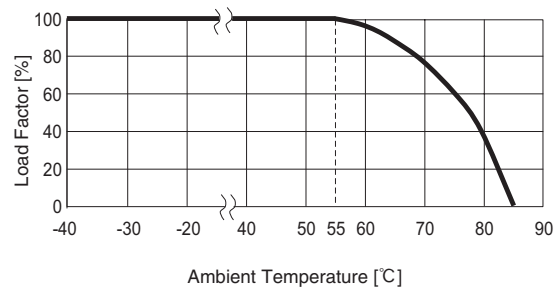

External view

Standard Type

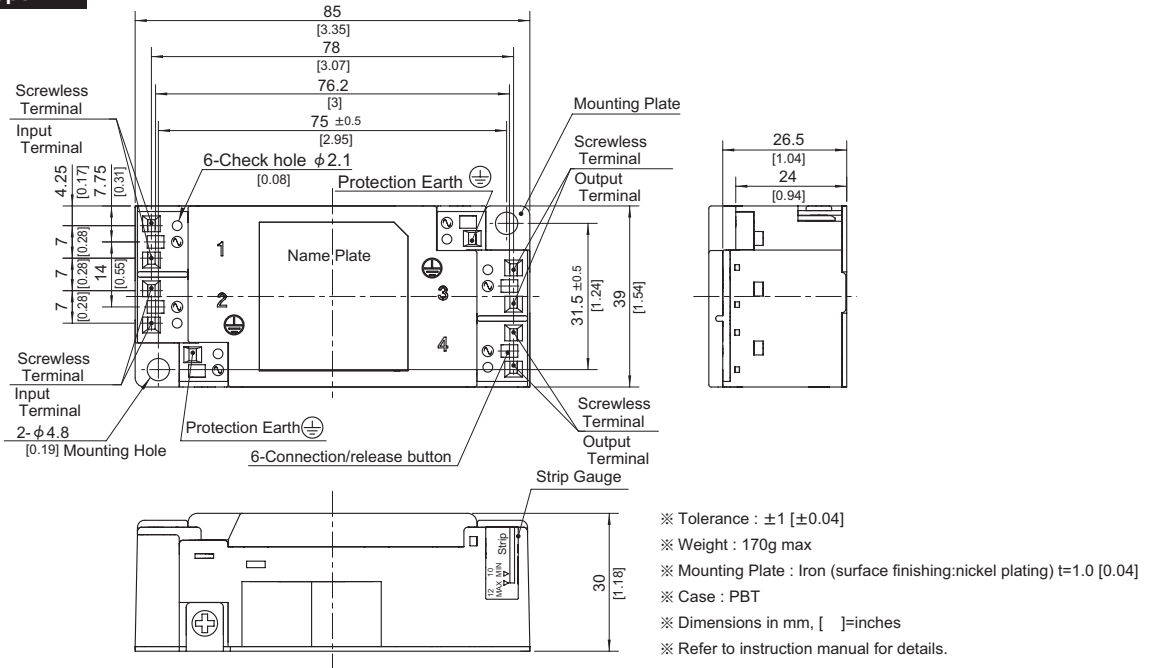

DIN rail installation Type

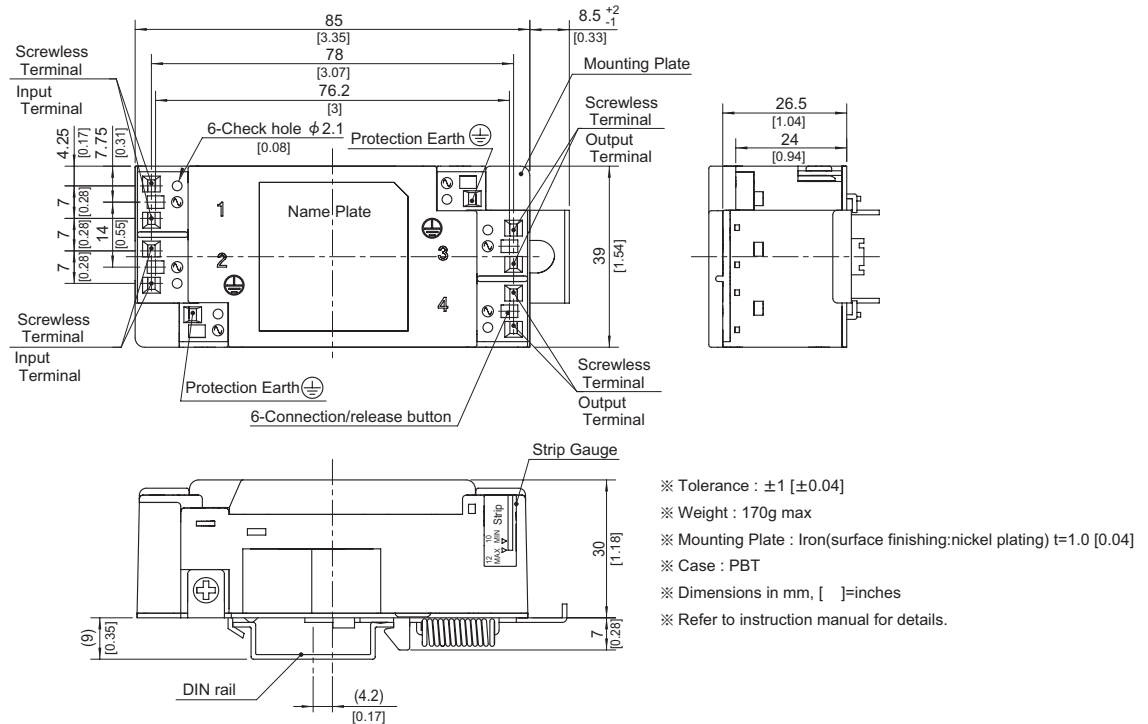

■Note when installing the EMI/EMC Filter on a DIN rail.

When the EMI/EMC Filter is grounded through the DIN rail, the proper noise attenuation may not be achieved.

Be sure to connect the protection earth (PE) of the EMI/EMC Filter body to the earth. At least one PE connection is required.

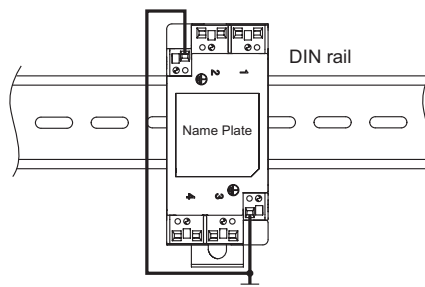

EAC-03-472 / ESC-03-472

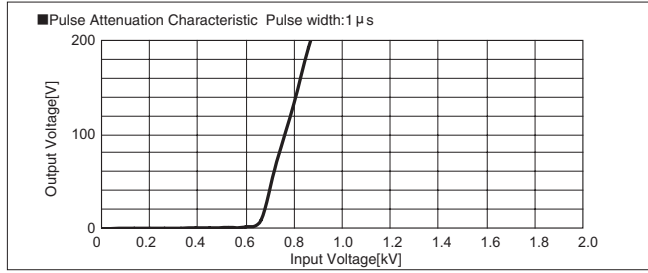
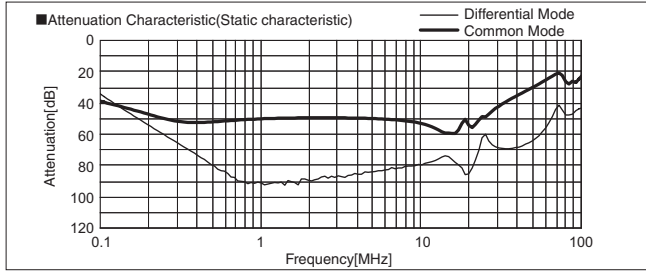

EAC-06-472 / ESC-06-472

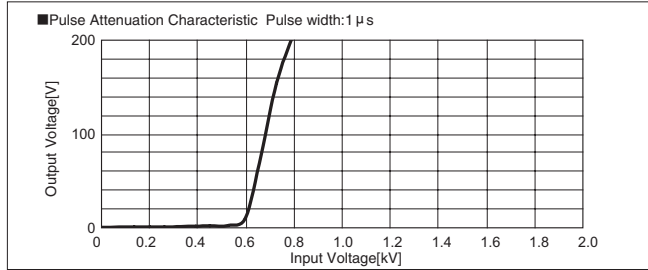
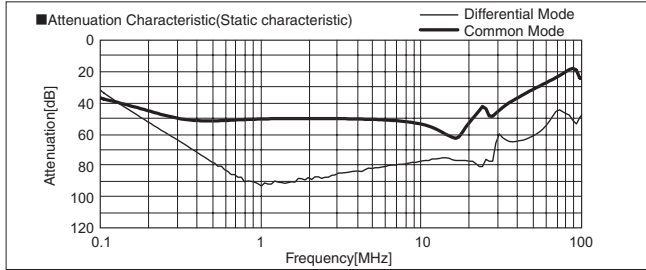

EAC-10-472 / ESC-10-472

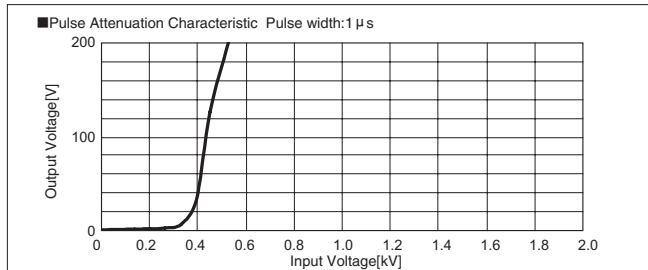
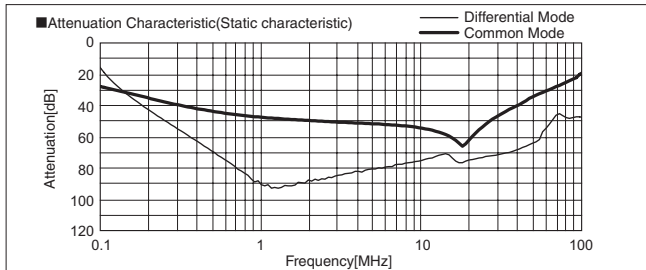

EAC-16-472 / ESC-16-472

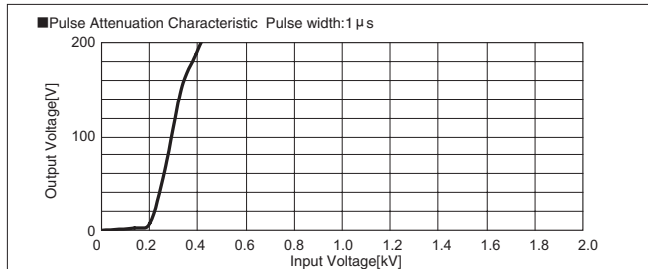
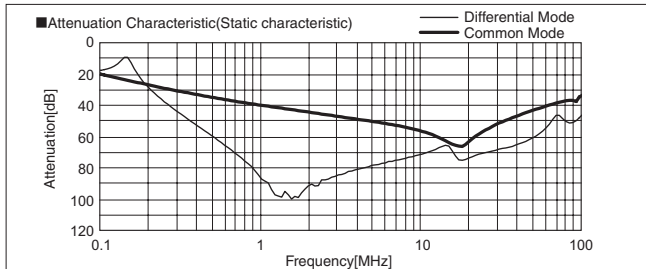

EAC-20-472

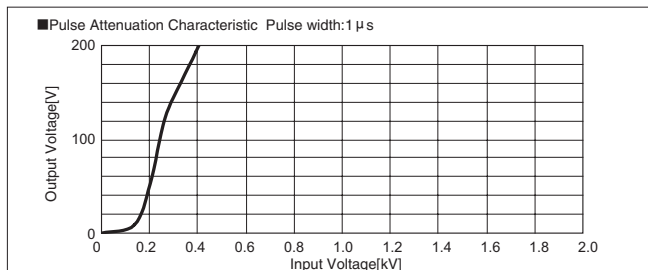
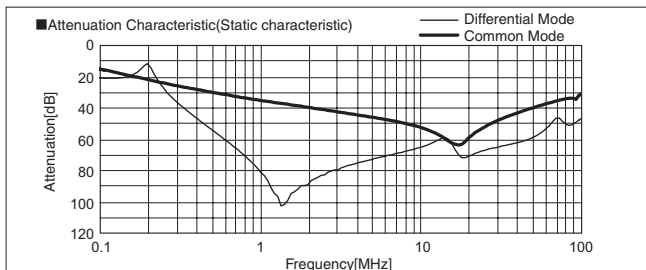

EAC-30-472

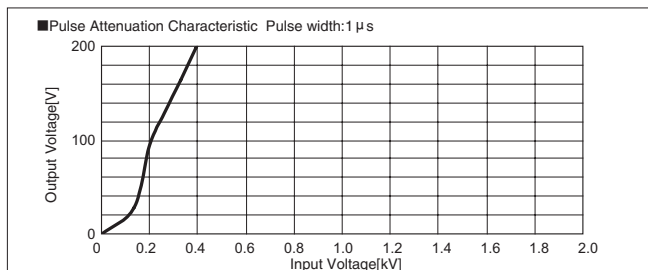
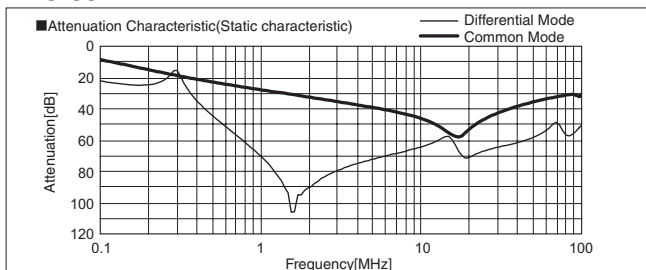

EAM-03-000 / ESM-03-000

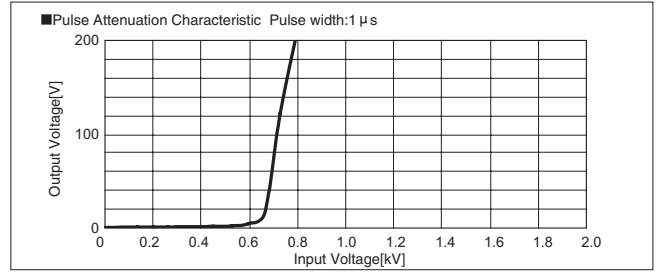
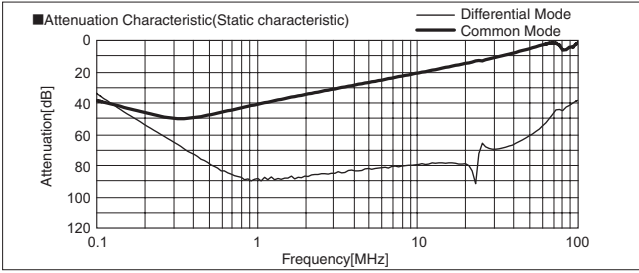

EAM-06-000 / ESM-06-000

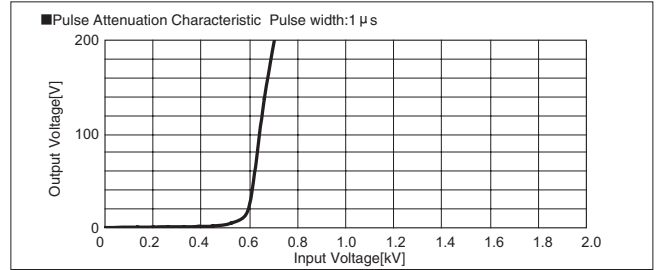
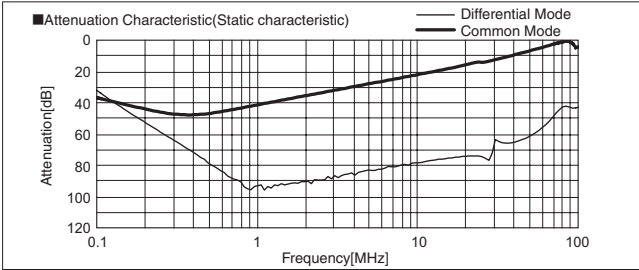

EAM-10-000 / ESM-10-000

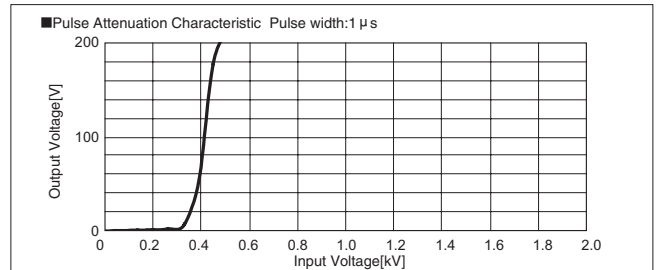
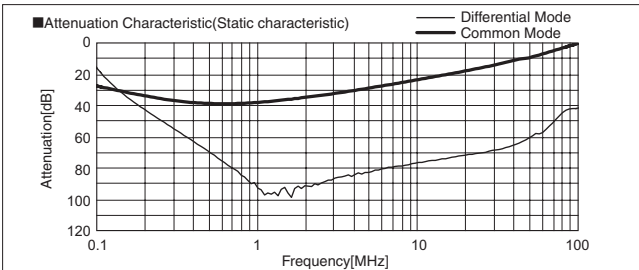

EAM-16-000 / ESM-16-000

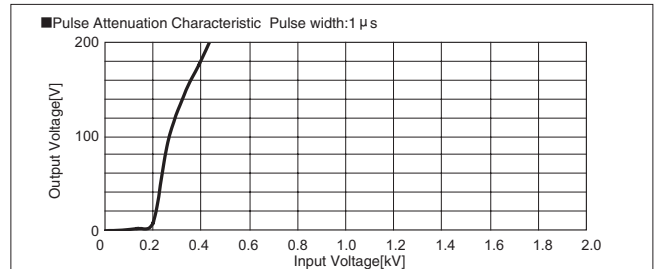
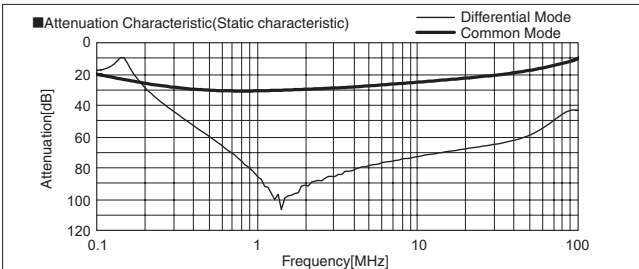

EAM-20-000

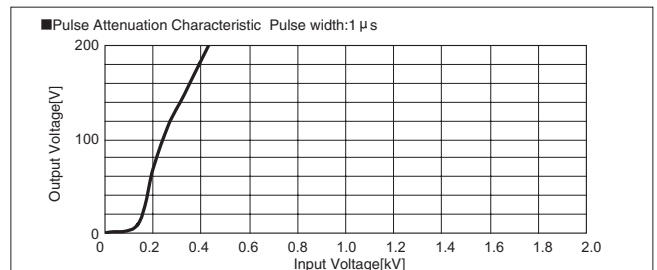
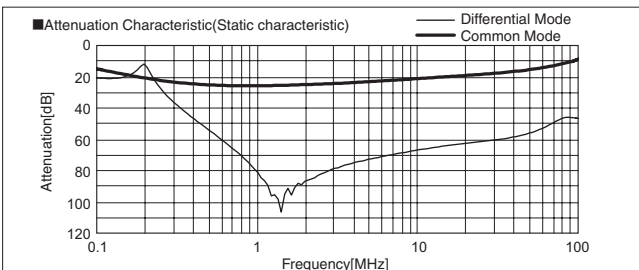

EAM-30-000

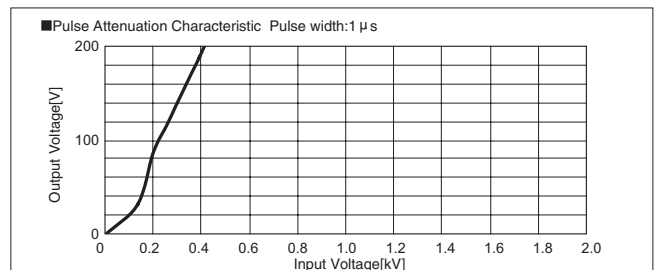
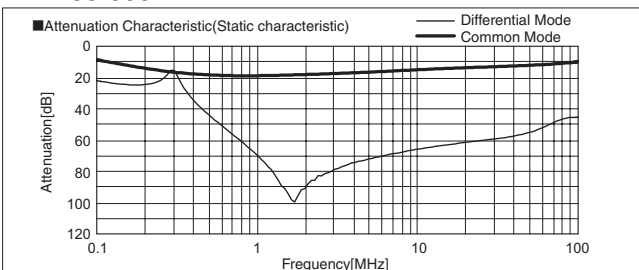

EAP-03-472 / ESP-03-472

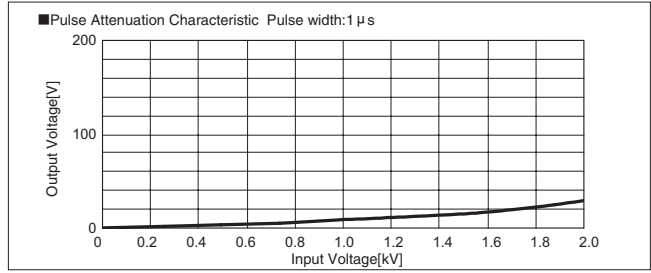
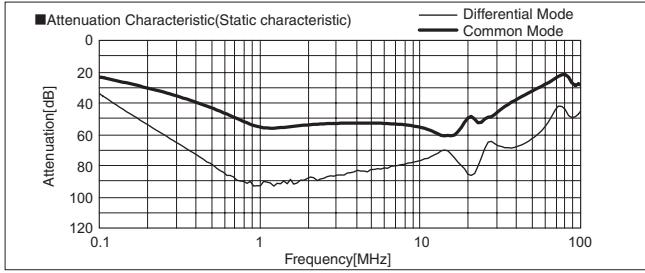

EAP-06-472 / ESP-06-472

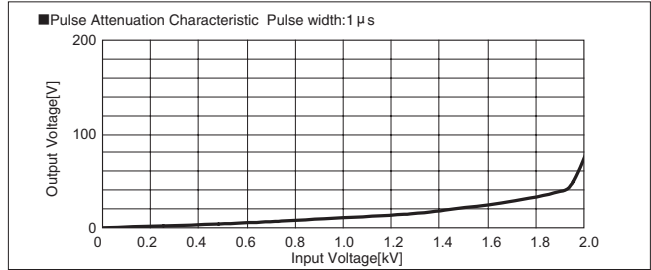
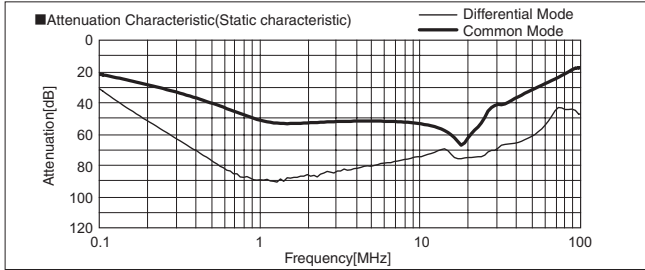

EAP-10-472 / ESP-10-472

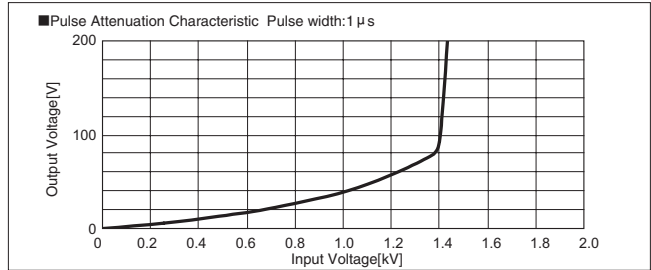
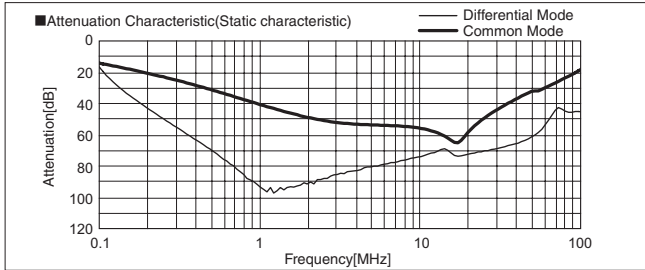

EAP-16-472 / ESP-16-472

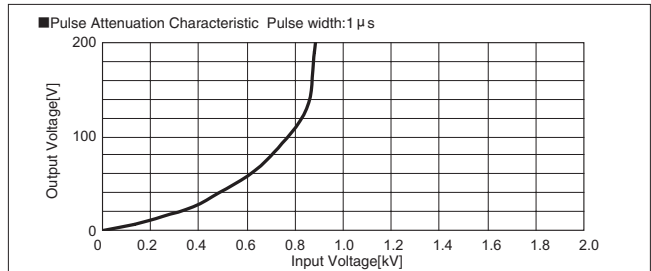
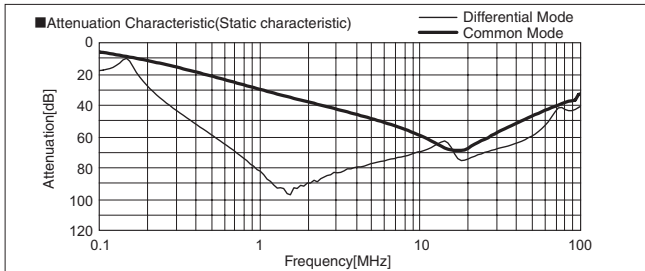

EAP-20-472

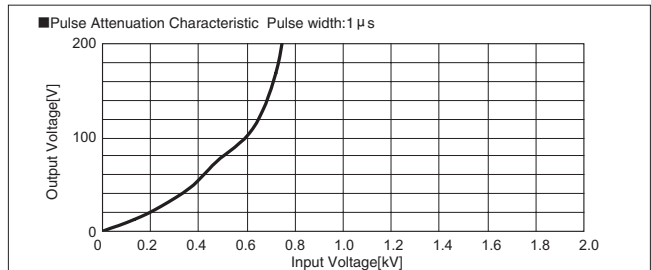
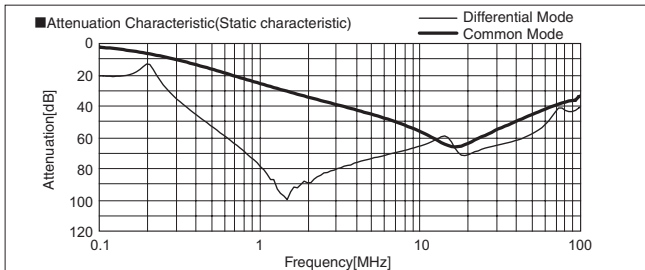

EAP-30-472

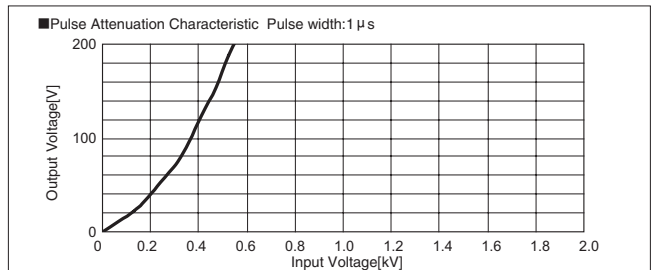
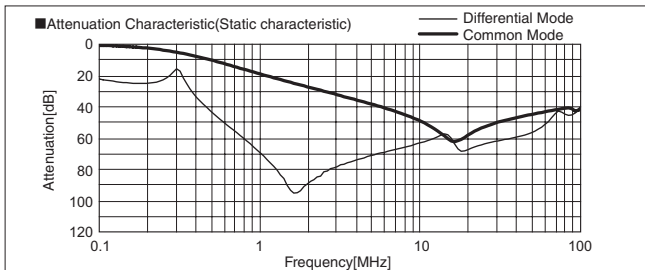

1 Applicable Electric Cable

- Only use the electric cable that exists in the Table1.
- Use the cable that conductor material is copper. Do not use the cable that conductor material is iron or aluminum. Never use the one other than the electric cable.
Ex. Steel wire, Stick made of resin, other wire
- Note that the current rating is different in each electric cable.
- Strip so as not to damage the conductor at stripping sheath.
- Strip specified length of cable sheath (Refer to Table1).
Strip Length can be confirmed with a gauge of the body case. Refer to External view.
- Do not put solder on the conductor. It becomes impossible to connect cable.

Table.1 Applicable Wire

Solid wire	Diameter 0.5mm to 1.2mm (AWG.22 to AWG.16)
Stranded wire	0.3mm ² to 1.25mm ² (AWG.22 to AWG.16) Conductor diameter more than 0.18 mm
Sheath strip length	10mm to 12mm

2 Applicable bar-type terminal

- The applicable bar-type terminal (Refer to Table 2) must be used, and after crimp, the size of bar-type terminal must be kept value of Table 3. Use the applicable terminal (Refer to Table 2) and keep the size of terminal, or you will not be able to connect cable. Contact us when the bar-type terminals other than the applicable bar-type terminal (Refer to Table 2) are used.
- Connect cable so as not to conceal the button with the sleeve of the cable when a round terminals other than the applicable terminal are used.

Table.2 Applicable bar-type terminal

Manufacturer	Size	model	Crimp tool
Phoenix Contact	AWG.22	AI0.34-12TQ	CRIMPFOX UD6-4
	AWG.20	AI0.5-10WH AI0.5-12WH	
	AWG.18	AI0.75-10GY AI0.75-12GY AI1-10RD AI1-12RD	
	AWG.16	AI1.5-10BK AI1.5-12BK	
Nichifu	AWG.22-16	TGN TC-1.25-11T TGV TC-1.25-11T	NH11 NH32 NH65

<Square type>

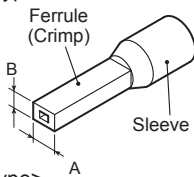

<Round type>

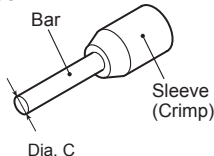
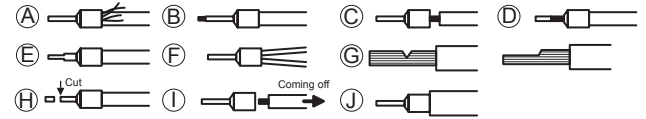

Table.3 Dimension of terminal at crimp
[Dimensions in mm]

Part	Dimension
A	1.1 to 2.6
B	0.8 to 1.6
Dia. C	0.8 to 1.6

3 State of crimped bar-type terminal

● Bad condition



- Ⓐ The wire protrudes from the sleeve.
- Ⓑ The conductor extremely protrudes from the point of the bar-type terminal.
- Ⓒ The electric conductor is not inserted enough and the conductor has been exposed from the terminal.
- Ⓓ The sheath strip length doesn't suffice and the conductor is not enough inserted in the ferrules.
- Ⓔ Crimp is only the point of conductor.
- Ⓕ It crimps two electric cables.
- Ⓖ There is a damage or a disconnection part in the conductor.
- Ⓗ The point of the terminal is cut.
- Ⓘ It comes off the terminal when the cable is pulled.
- ⓵ The sheath of the cable protrudes from the sleeve.

4 Wiring Terminal Blocks (connecting/releasing)

- One electric cable one insertion hole. When two or more is connected, it causes trouble.
- Do connecting and releasing of the electric cable by using a flat-blade driver while pushing the connection/release button. Moreover, insert the conductor or the bar-type terminal to the end fully.
- When you connect the stranded cable, connect wires after lightly stranding wires.
- Confirm the electric cable is surely connected with the terminal after connecting.
- The check hole can be used for the check of wire connecting and insulation and for the operation monitor etc.

● Connecting : Stranded cable, Solid cable (Diameter 0.5 to 0.9)

- StepI Push the button with a flat-blade driver.
- StepII Insert the cable into the hole while pushing the button.
- StepIII Release the flat-blade driver and cable connection is completion.

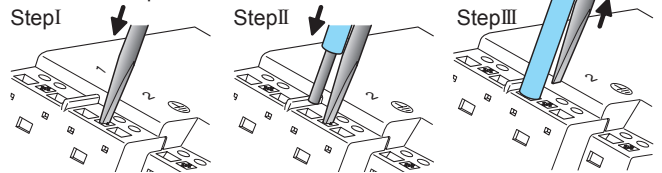

● Connecting : Solid wire (except diameter 0.5 to 0.9), bar type terminal

- Insert the cable into the insertion hole.
* Insert it while pushing the button when it is not easy to insert it.

● Releasing : Stranded wire, Solid wire, bar type terminal

- Pull out the electric cable while pushing the button with flat-blade driver.
* Notice : Two insertion holes are released at the same time by pushing the button once. (Except PE terminal)

- Use the flat-blade driver that meets the size in Table 4.

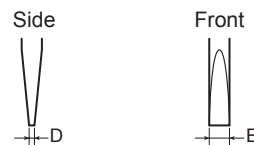

Table.4 Dimension of flat-blade driver
[Dimensions in mm]

Part	Dimension
D	1.0max
E	3.0max

NAC/NAM/NAH/NAP series(4-30A)

NAC -10 -472 -□

① ② ③ ④

- ① Series Name
- ② Rated Current
- ③ Line to ground capacitor code: Refer to table 1.1.

table 1.1 Line to ground capacitor code

Code	N A C	N A H	N A P	Leakage Current (Input 125/250V 60Hz)	Line to ground capacitor (nominal value)
000	●	●	●	5 μ A / 10 μ A max	Not Provided
101	●	●	●	12.5 μ A / 25 μ A max	100pF
221	●	●	●	25 μ A / 50 μ A max	220pF
331	●	●	●	37.5 μ A / 75 μ A max	330pF
471	●	●	●	50 μ A / 100 μ A max	470pF
681	●	●	●	75.5 μ A / 150 μ A max	680pF
102	●	●	●	0.13 mA / 0.25mA max	1,000pF
222	●	●	●	0.25 mA / 0.5 mA max	2,200pF
332	●	●	●	0.38 mA / 0.75mA max	3,300pF
472	●	●	●	0.5 mA / 1.0 mA max	4,700pF

* When the line to ground capacitor code is different, the attenuation characteristic is different.

- ④ Option
- D: DIN rail installation type

* The dimensions change when the option is set. Refer to External view.

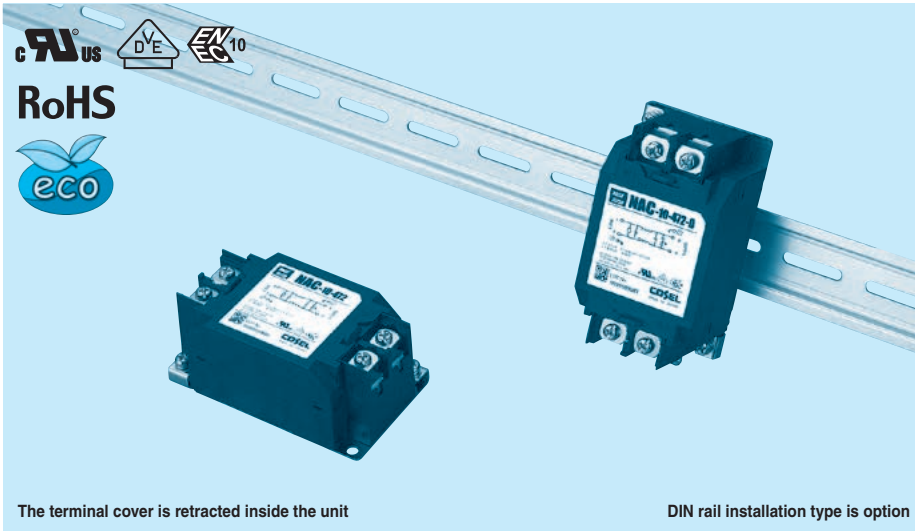

The terminal cover is retracted inside the unit

DIN rail installation type is option

Features of NAC/NAM/NAH/NAP series

- Single Phase 250VAC (1-Stage filter)
 - Quick and easy push-down terminal
- Just connect the wires, push-down and tighten the screws with a screwdriver

- NAC : High-attenuation type from 150kHz to 1MHz
- NAM: Low leakage current type
- NAH: Ultra high-attenuation type from 9kHz to 1MHz
- NAP : Outside impulse high-attenuation type

Specifications

No.	Items	NAC-04-472	NAC-06-472	NAC-10-472	NAC-16-472	NAC-20-472	NAC-30-472
		NAM-04-000	NAM-06-000	NAM-10-000	NAM-16-000	NAM-20-000	NAM-30-000
		-	NAH-06-472	NAH-10-472	NAH-16-472	NAH-20-472	NAH-30-472
		NAP-04-472	NAP-06-472	NAP-10-472	NAP-16-472	NAP-20-472	NAP-30-472
1	Rated Voltage[V]	AC 1 ϕ 250 / DC250					
2	Rated Current[A]	4	6	10	16	20	30
3	Test Voltage (Terminal-Mounting Plate)	2,500 VAC (Cutoff Current = 20mA), 1minute at room temperature and humidity					
4	Isolation Resistance (Terminal-Mounting Plate)	500 VDC 100M Ω min at room temperature and humidity					
5	Leakage current	Refer to table 1.1					
6	Voltage drop	1.0V max					
7	Safety agency approval temperatures	-25 to +85°C (Refer to Derating Curve)					
8	Operating temperature	-40 to +85°C (Refer to Derating Curve)					
9	Operating humidity	20 to 95%RH (Non condensing)					
10	Storage temperature/humidity	-40 to +85°C/20 to 95%RH (Non condensing)					
11	Vibration	10 to 55Hz, 19.6m/s ² (2G), 3min. Period, 1hour each X, Y and Z axis					
12	Impact	196.1m/s ² (20G), 11ms Once each X, Y and Z axis					
13	Safety agency approvals	UL1283, CSA C22.2 No.8 (C-UL), DIN EN60939 VDE0565 Teil3-1, ENEC (At only AC input)					
14	Case size (without projection) /Weight	53X41X92 mm [2.09X1.61X3.62 inches] (W X H X D) /300g max (Option : -D refer to external view)					

Circuit Diagram

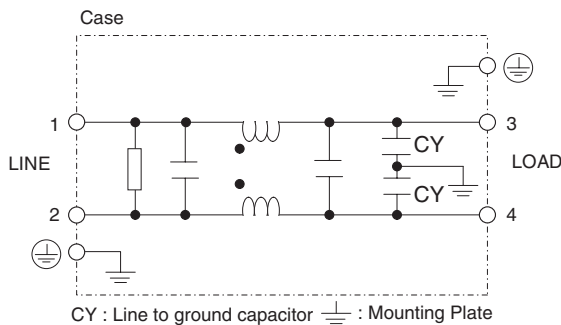

Derating Curve

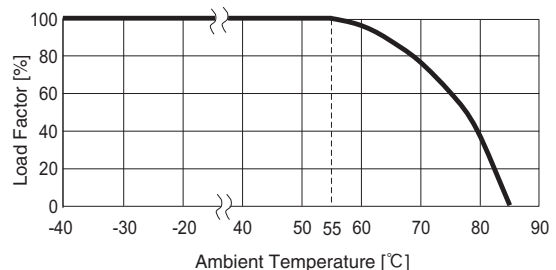

External view

This product is shipped in the following condition, because it is equipped with push-down terminals.

- ① The terminal cover is retracted inside the unit.
- ② The screws for connecting the terminals are held in the up right position.

Standard Type

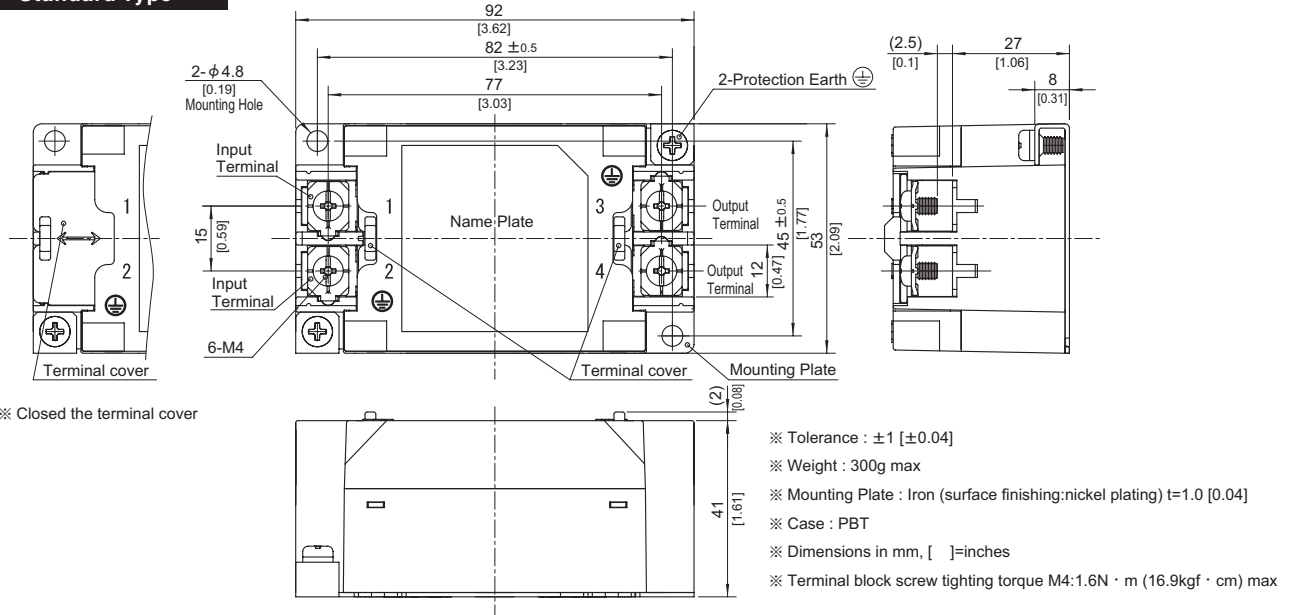

DIN rail installation Type

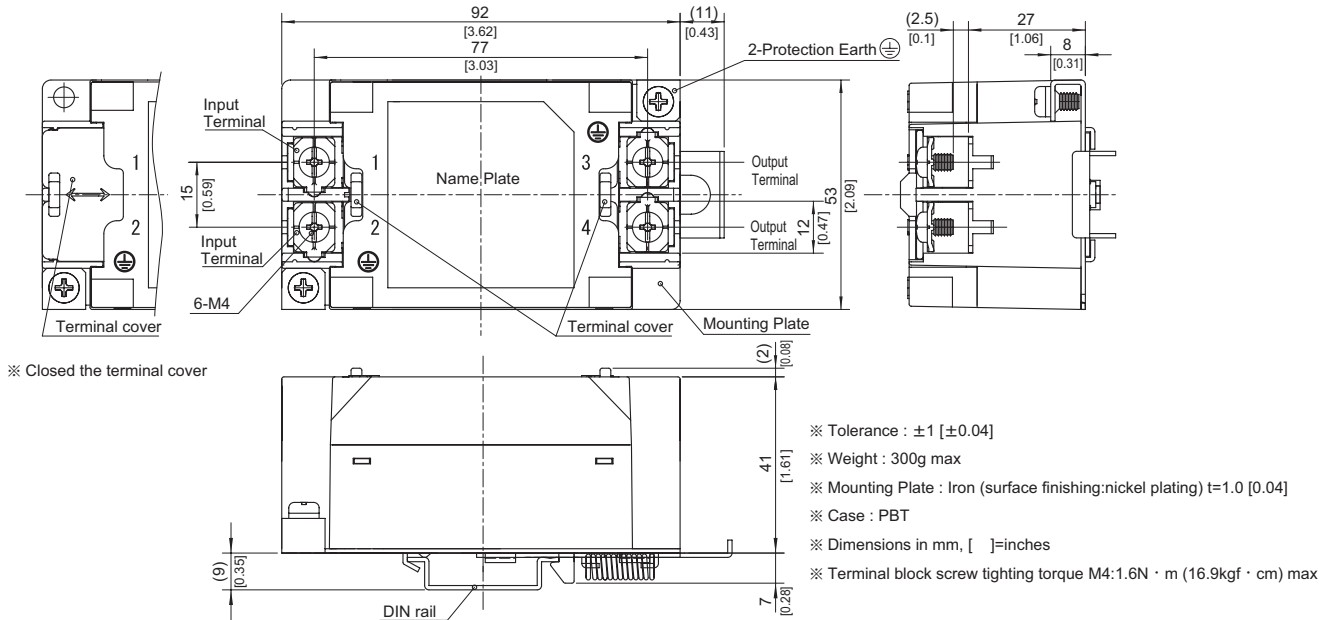

■Note when installing the EMI/EMC Filter on a DIN rail.

When the EMI/EMC Filter is grounded through the DIN rail, the proper noise attenuation may not be achieved.

Be sure to connect the protection earth (PE) of the EMI/EMC Filter body to the earth. At least one PE connection is required.

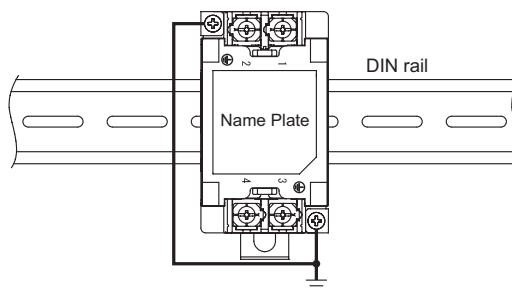

NAC-06-472

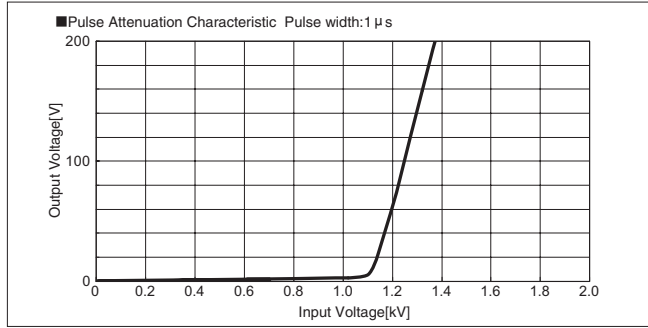
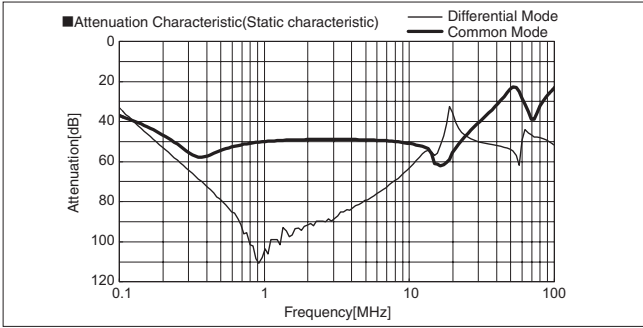

NAC-10-472

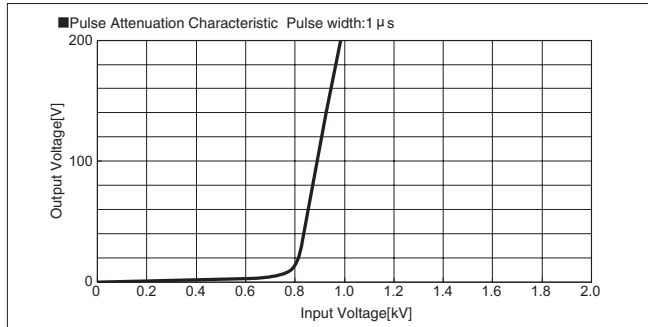
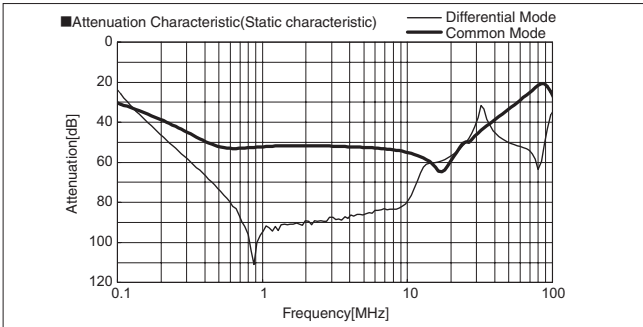

NAC-16-472

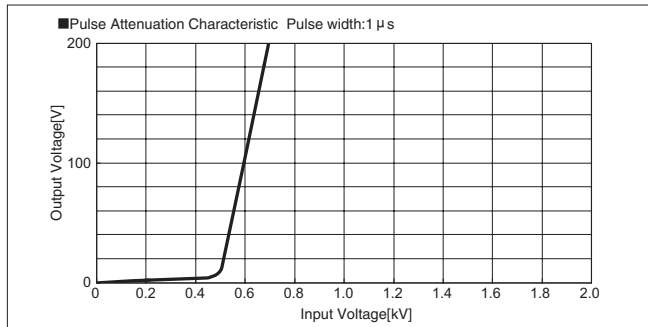
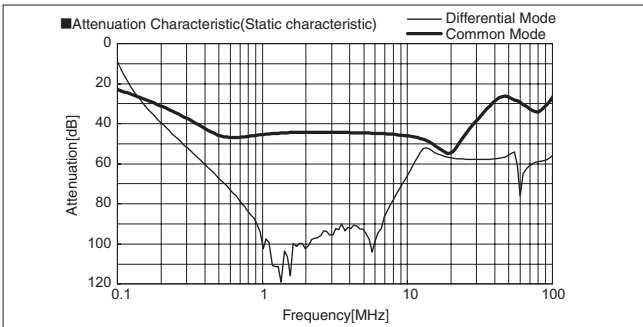

NAC-20-472

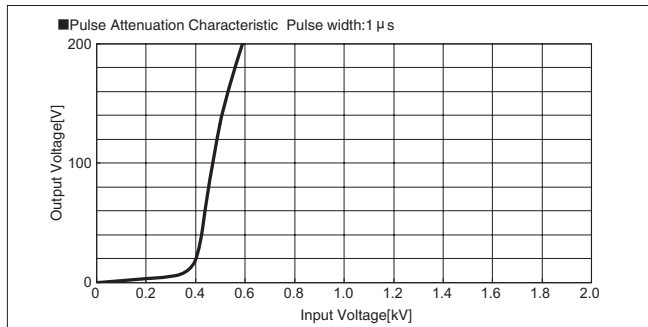
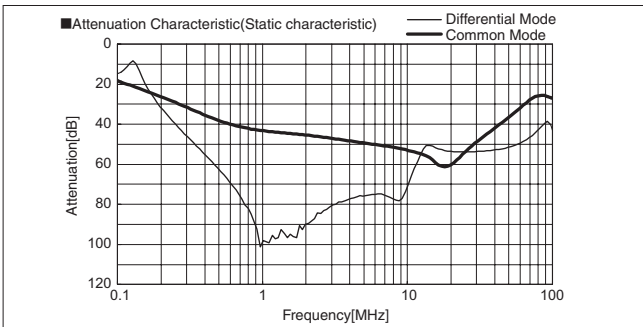

NAC-30-472

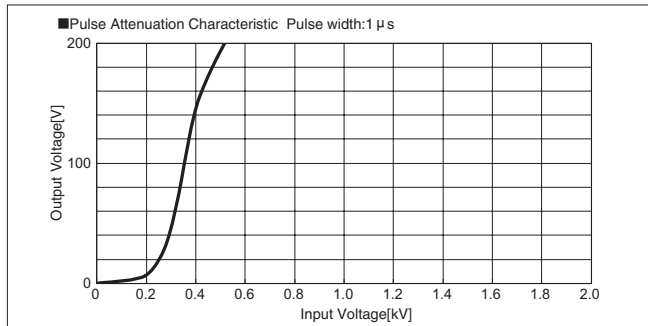
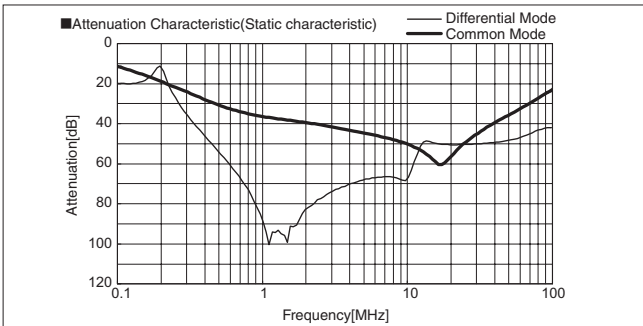

■Characteristic example of conductive noise reduction.

Reference data (PBA150F-5-G : Low leakage current type)

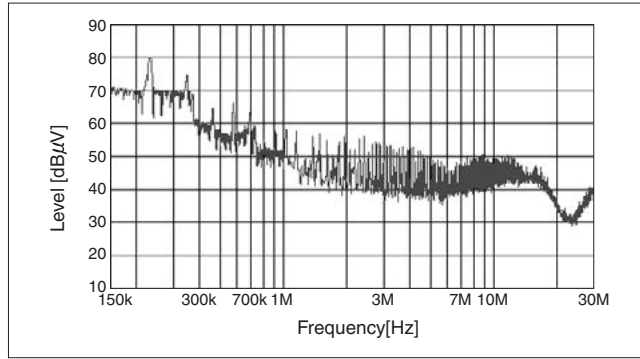

NAC-06-472+PBA150F-5-G

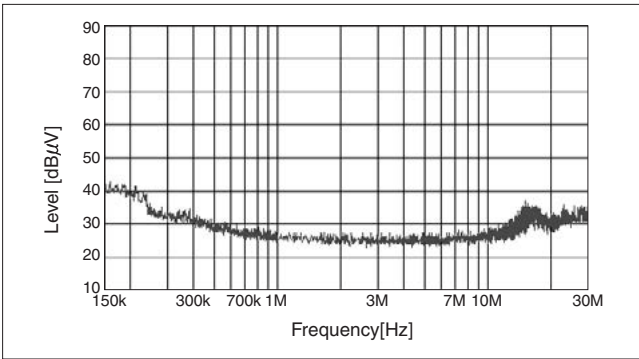

NAC-10-472+PBA150F-5-G

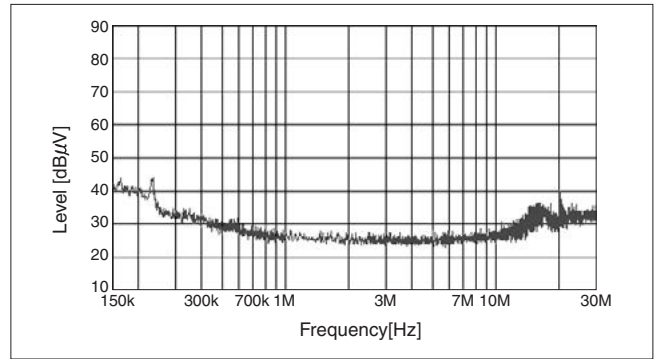

NAC-16-472+PBA150F-5-G

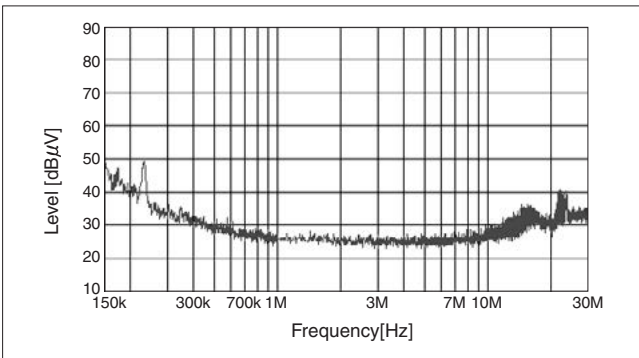

NAC-20-472+PBA150F-5-G

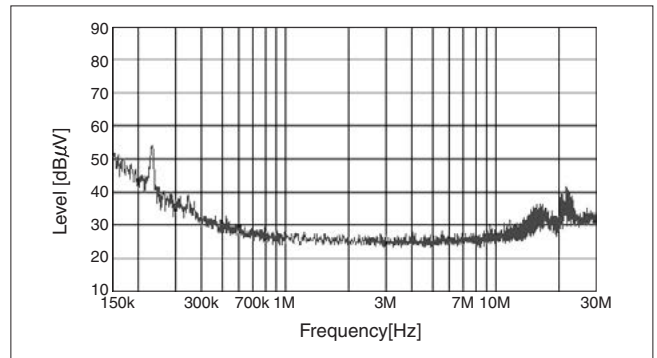

NAC-30-472+PBA150F-5-G

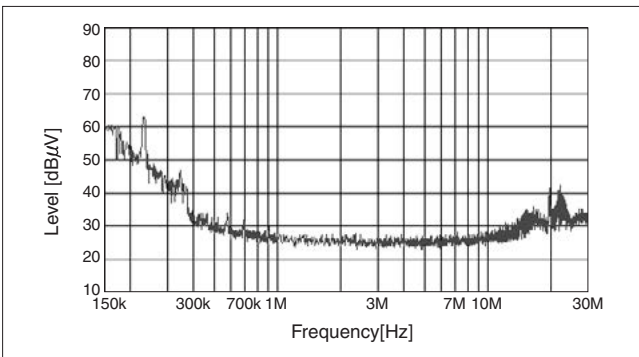

Condition : 230 VAC, I_o=100%

NAM-06-000

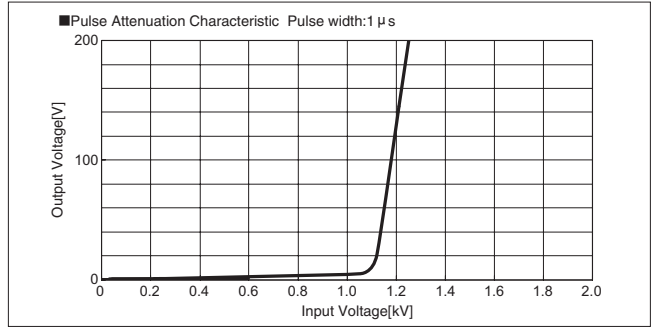
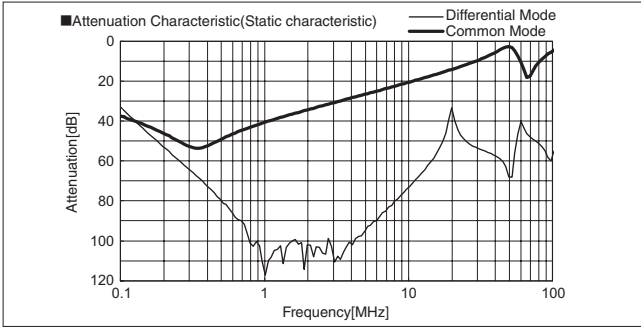

NAM-10-000

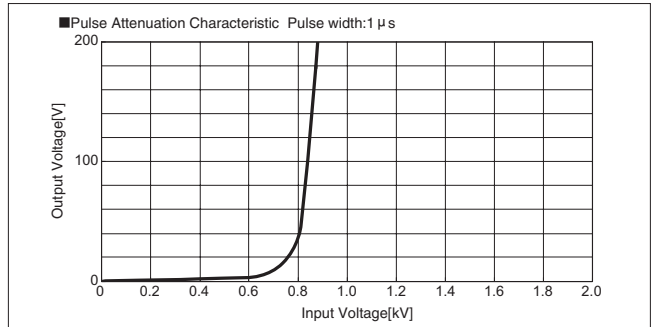
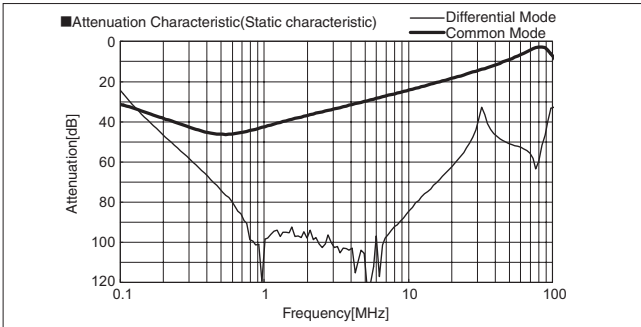

NAM-16-000

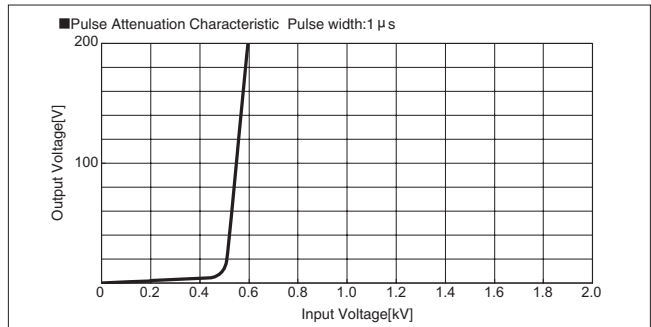
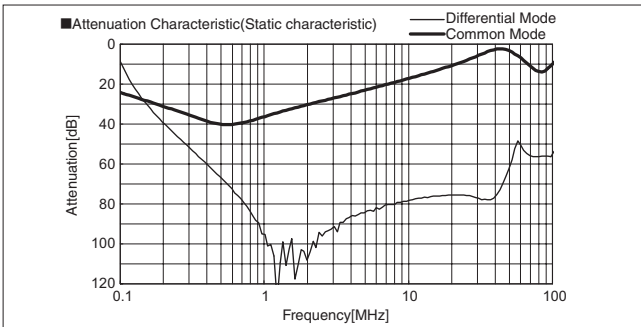

NAM-20-000

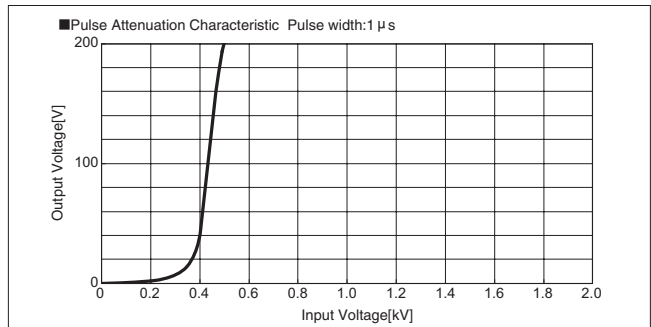
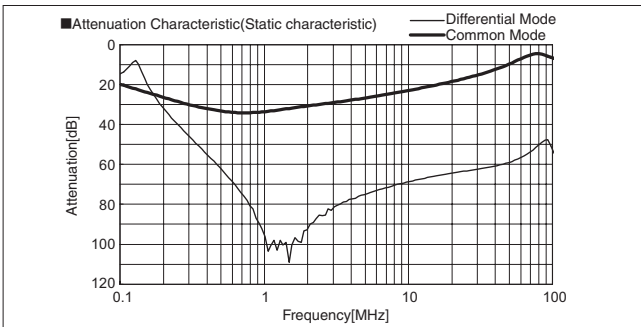

NAM-30-000

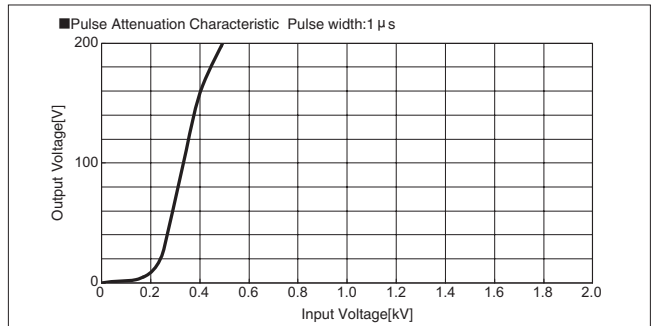
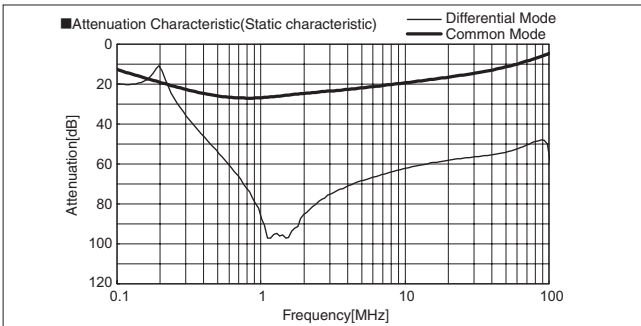

NAH-06-472

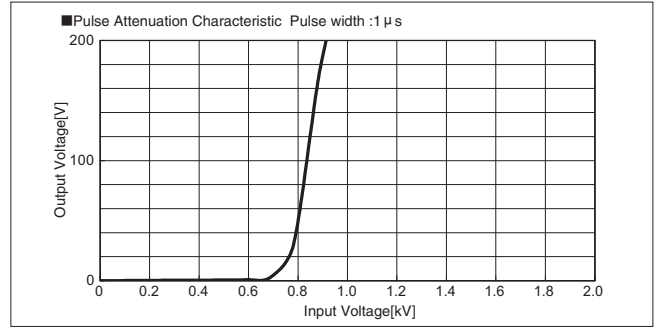
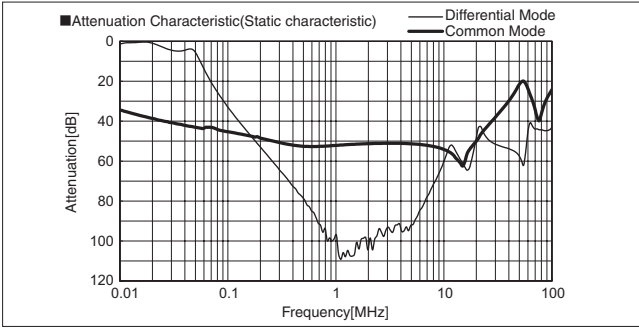

NAH-10-472

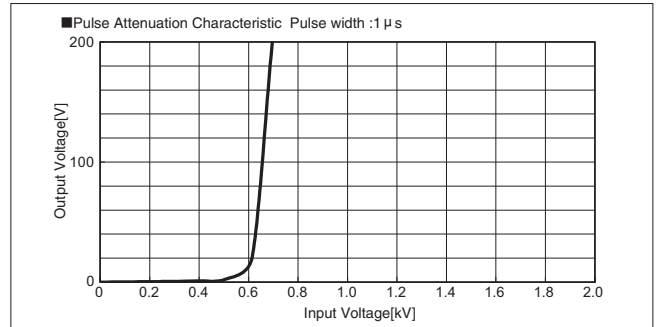
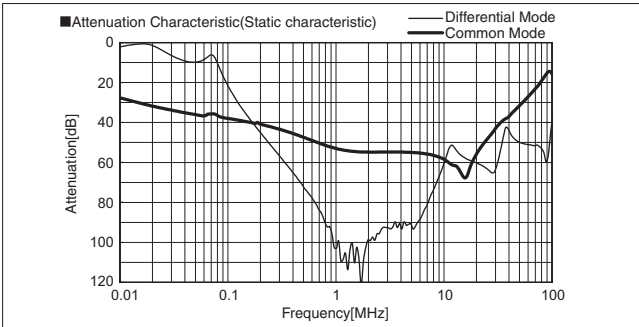

NAH-16-472

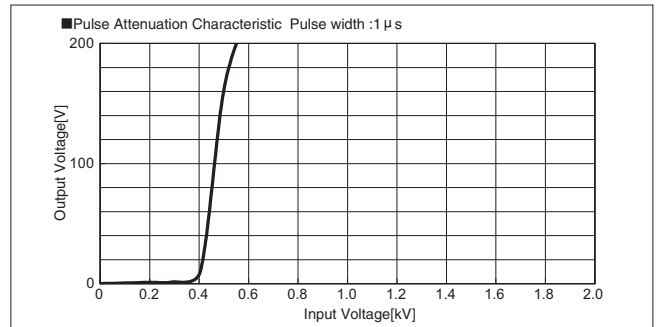
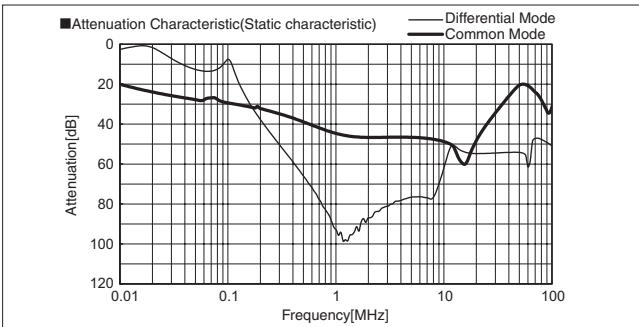

NAH-20-472

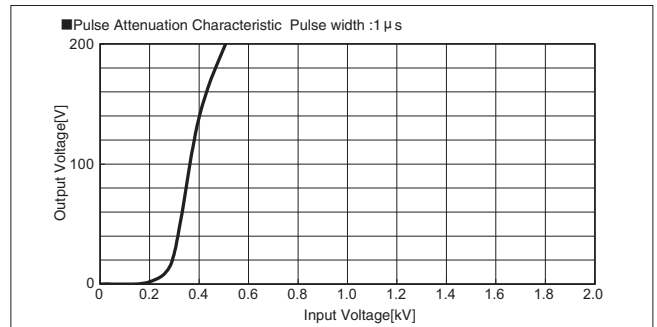
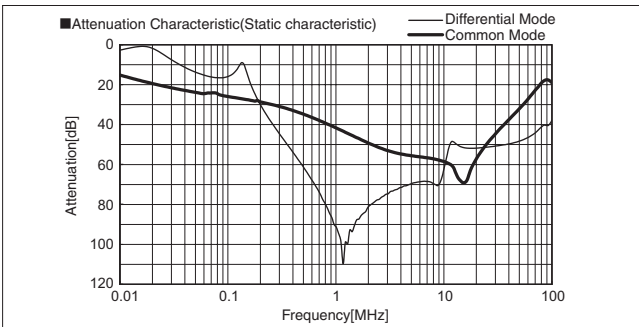

NAH-30-472

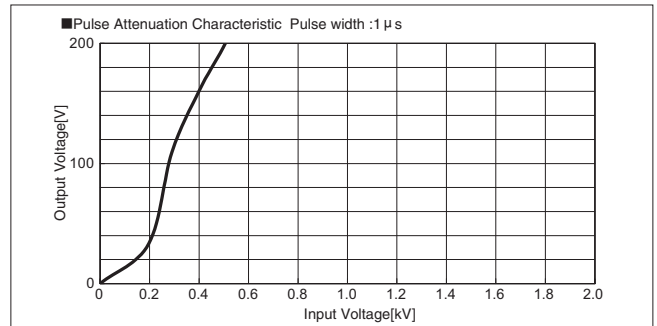
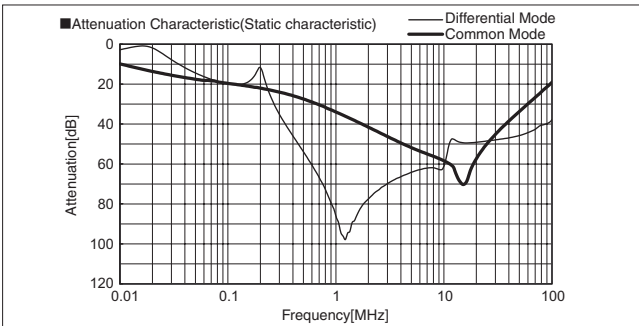

NAP-06-472

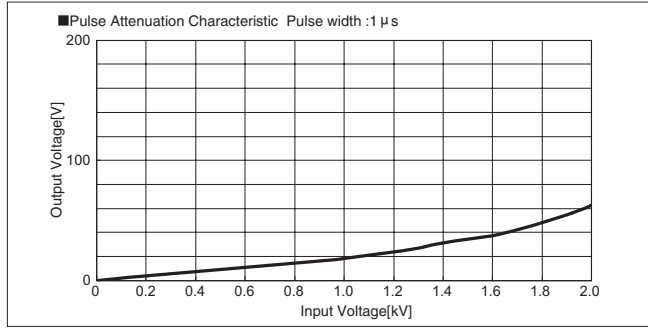
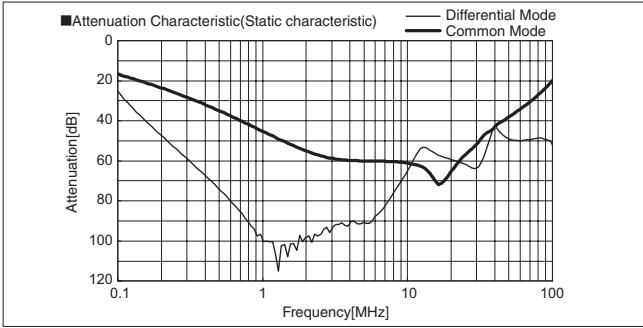

NAP-10-472

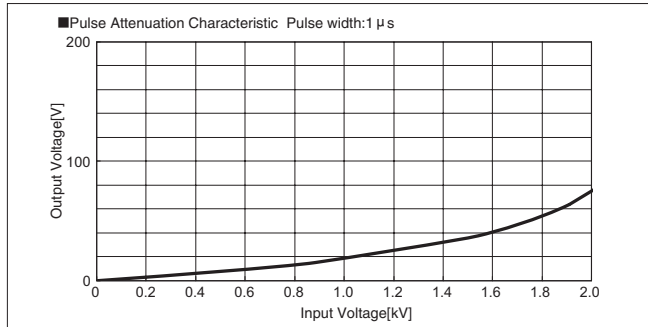
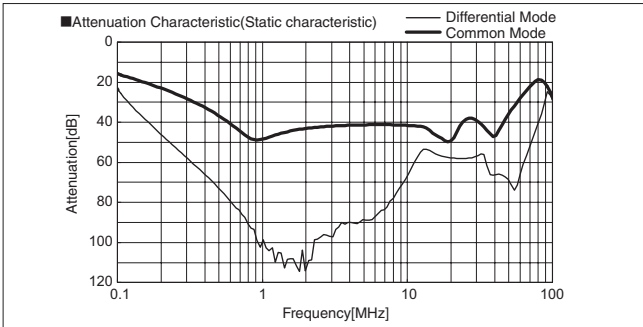

NAP-16-472

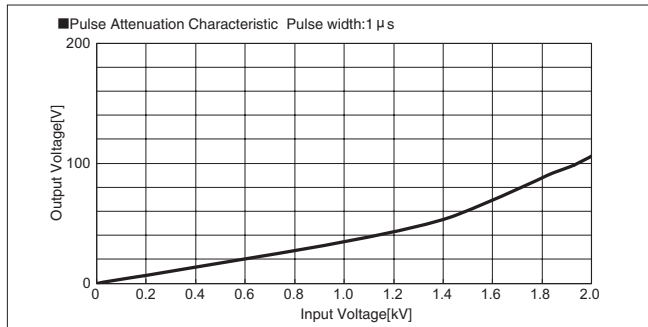
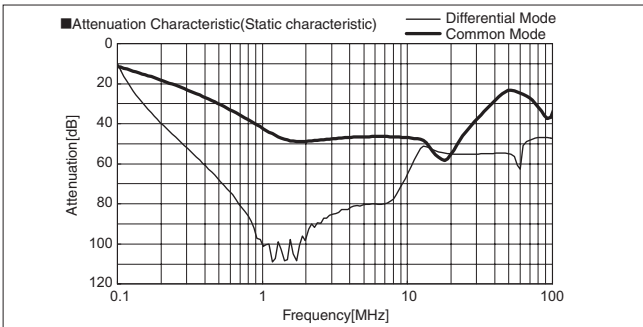

NAP-20-472

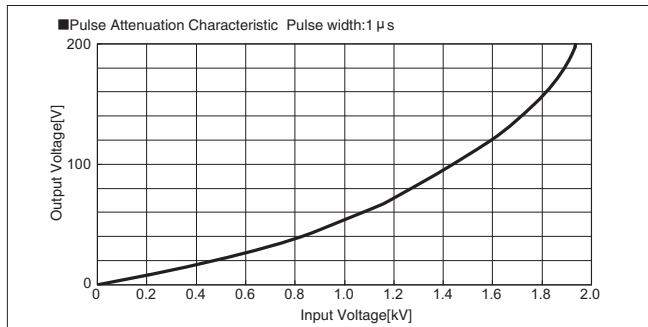
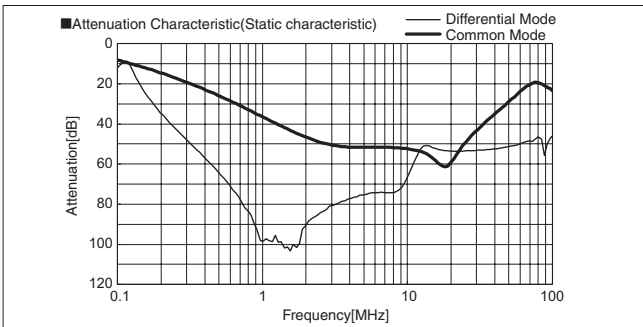

NAP-30-472

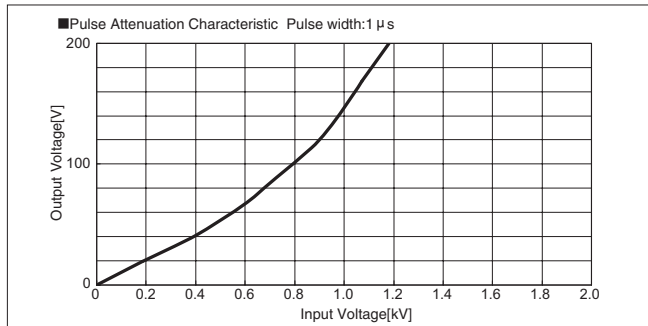
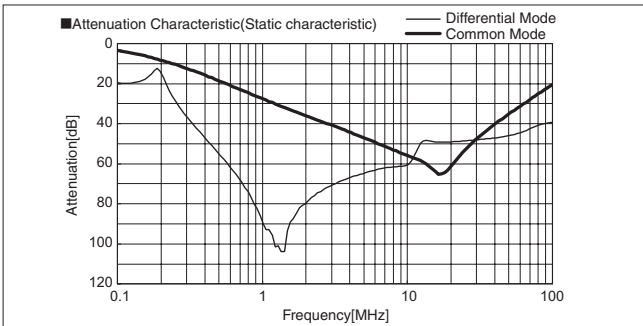

Circuit Diagram

(1) Line to ground capacitor code :000,471,222,472,223

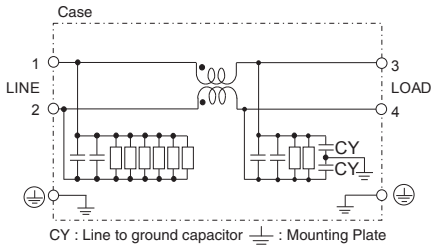

(2) Line to ground capacitor code :683

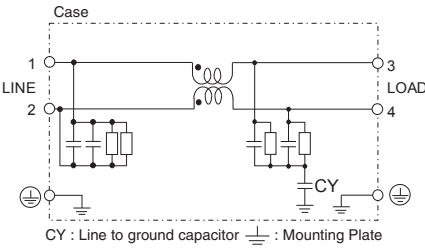

(3) Line to ground capacitor code :224,155

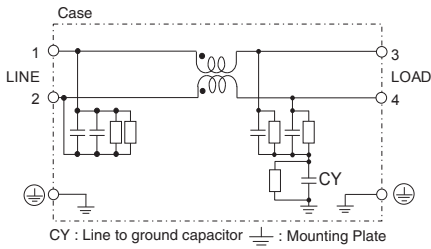

(4) Line to ground capacitor code :103,223,683
Option : F

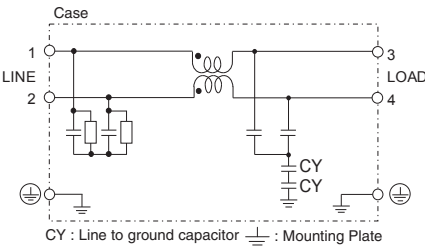

Derating Curve

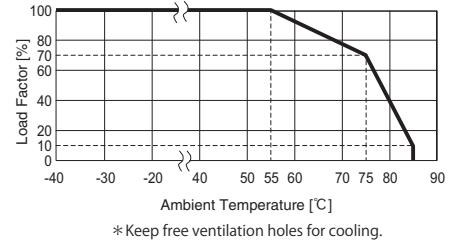

External view

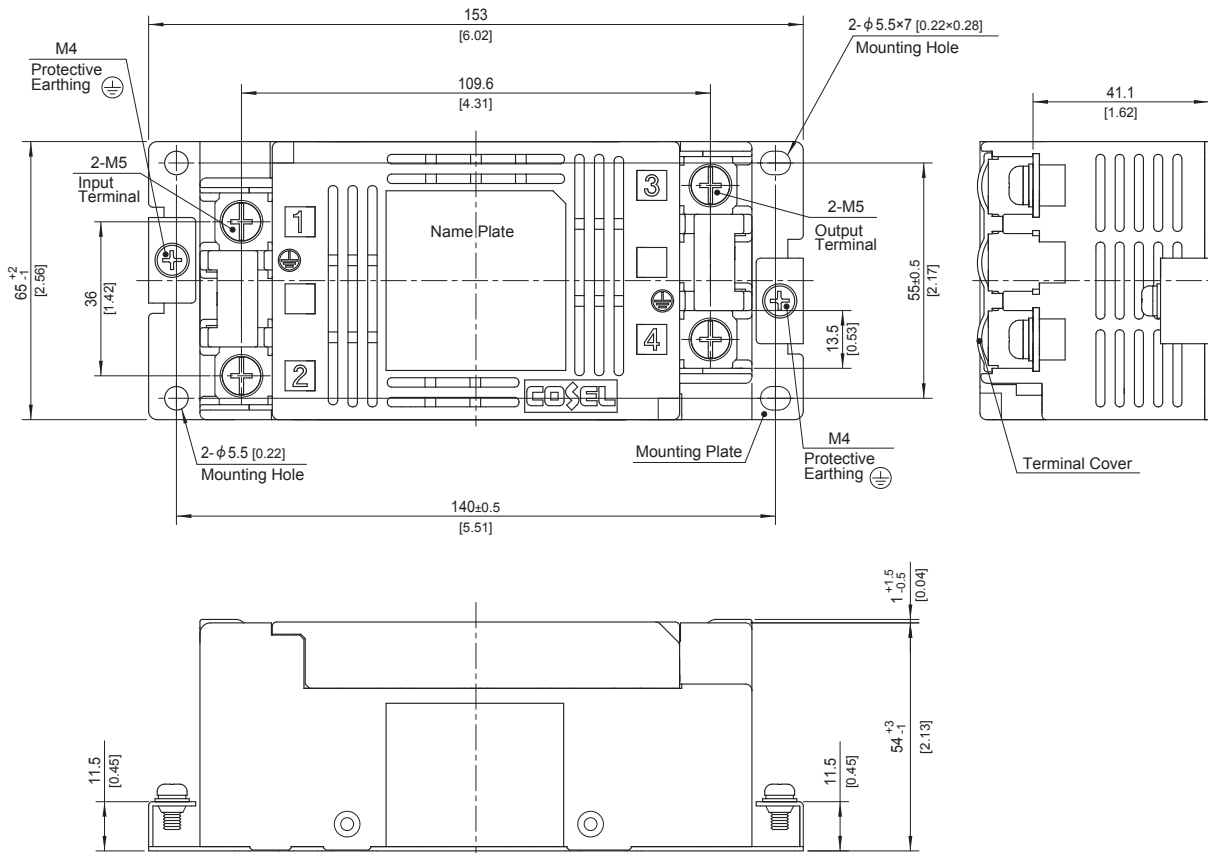

- ※ Dimensions in mm, []=inches
- ※ Tolerance: ± 1 [± 0.04]
- ※ Weight: 750g max
- ※ Mounting Plate: Hot-dip Galvanized Steel board t=1.0 [0.04]
- ※ Case Material: PBT
- ※ Terminal block screw tightening torque M5: 3.0N·m max
- ※ Protective Earthing (PE) screw tightening torque M4 : 1.6N·m max
- ※ Can not be mounted upside-down. (mounted the top surface)
- ※ Keep free ventilation holes for cooling.
- ※ Can be mounted using the 2 corner mounting holes.

NAC-40-472

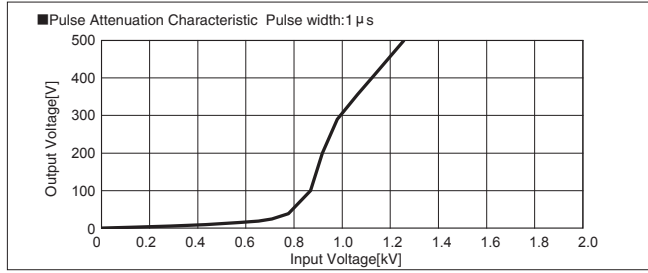
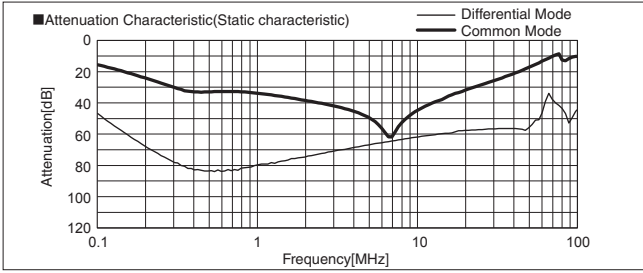

NAC-40-155

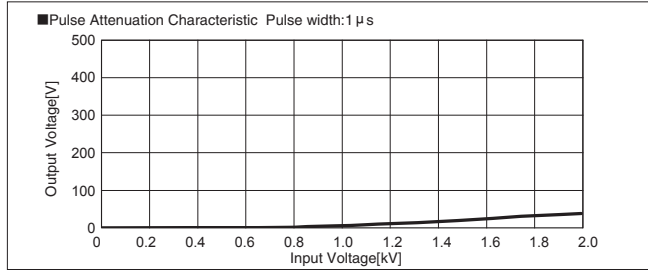
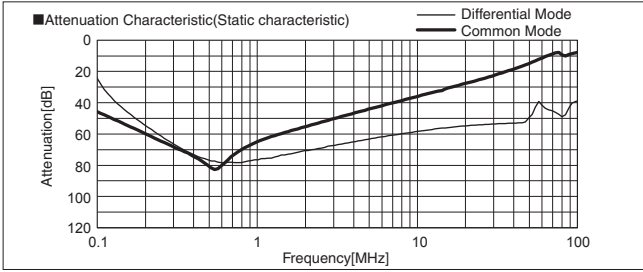

NAC-50-472

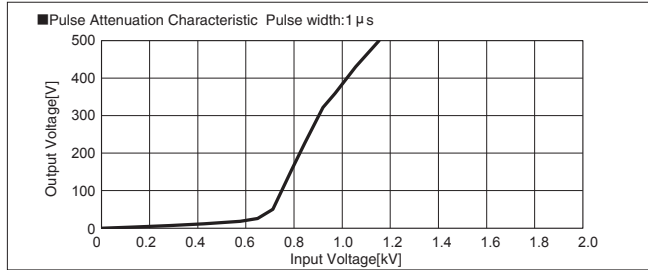
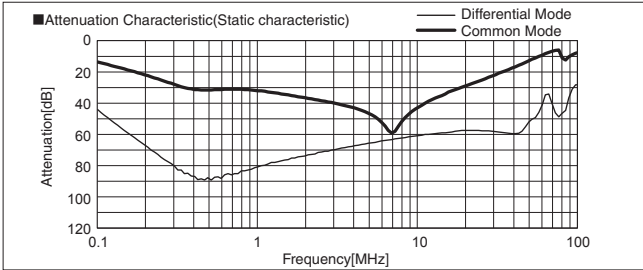

NAC-50-155

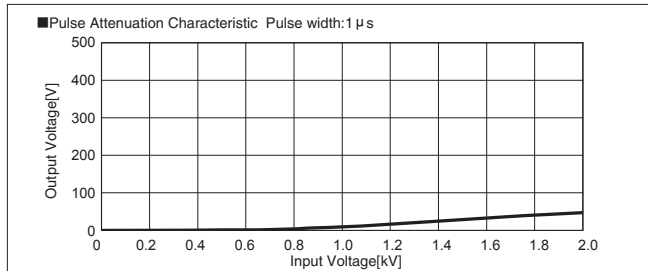
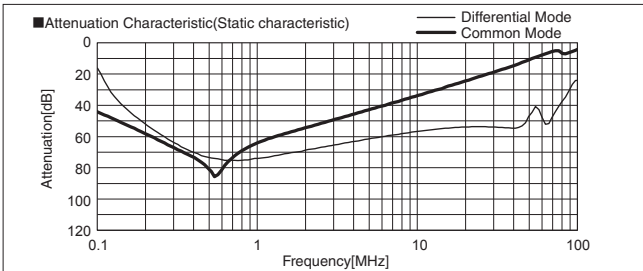

NAC-60-472

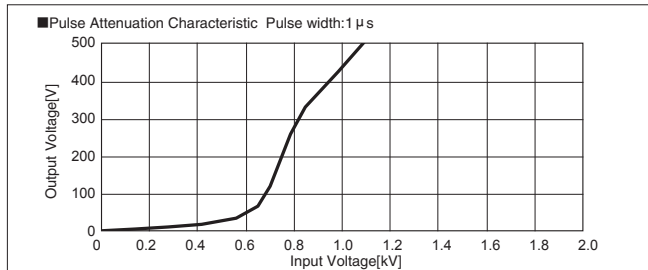
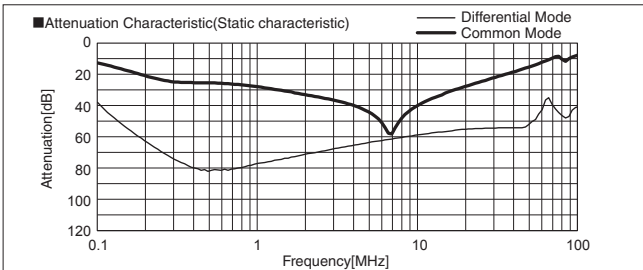

NAC-60-155

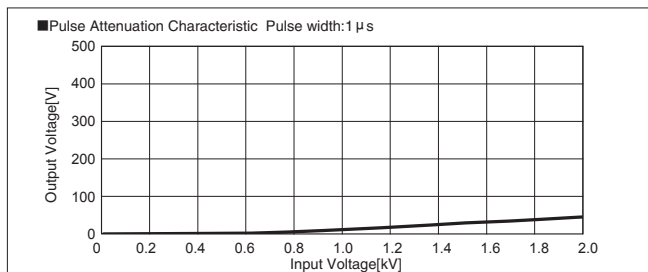
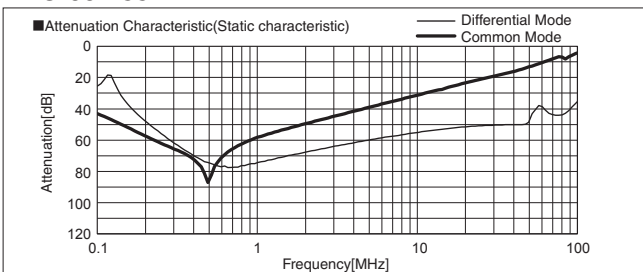

NAM-40-000

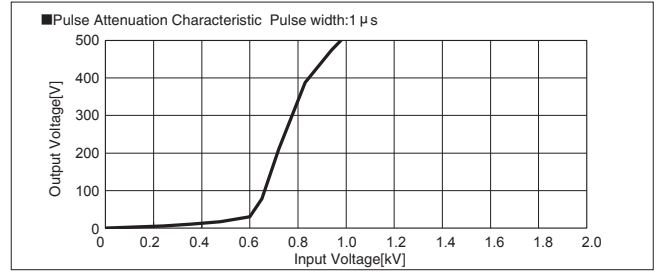
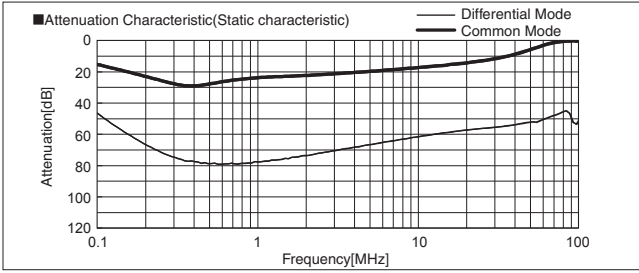

NAM-50-000

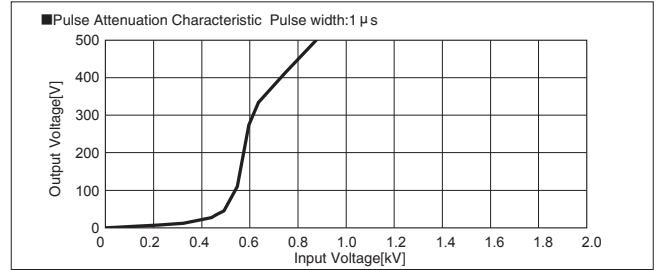
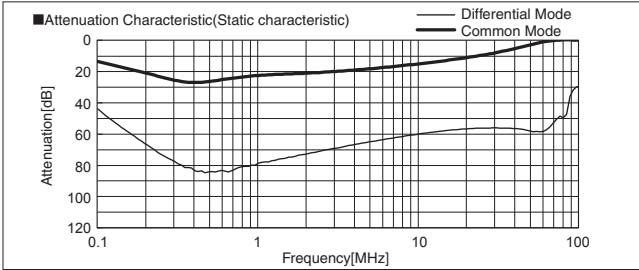

NAM-60-000

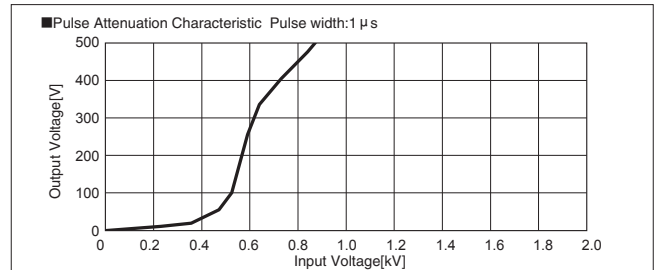
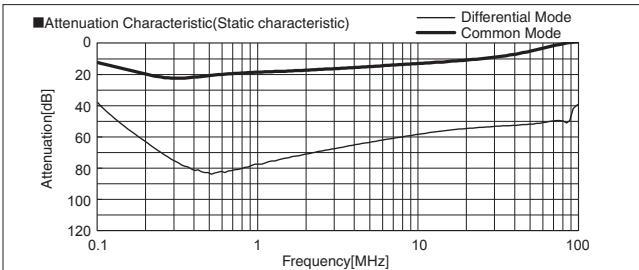

NAH-40-472

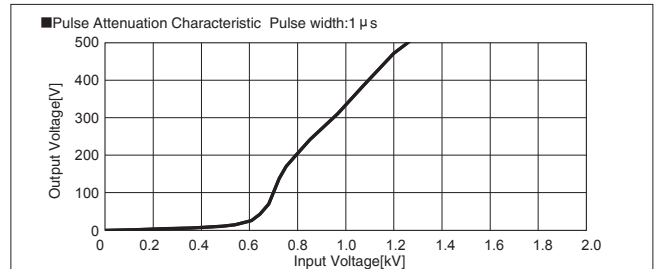
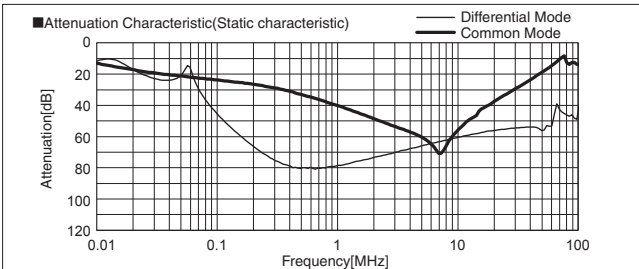

NAH-50-472

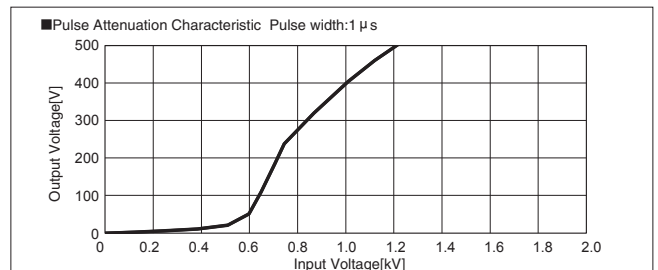
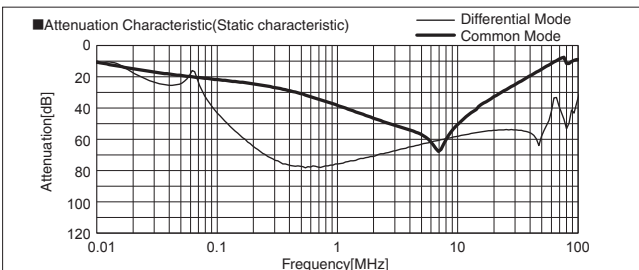

NAH-60-472

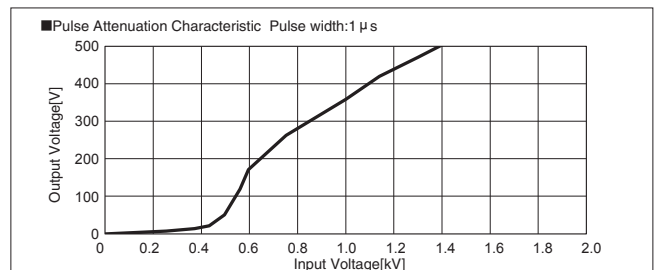
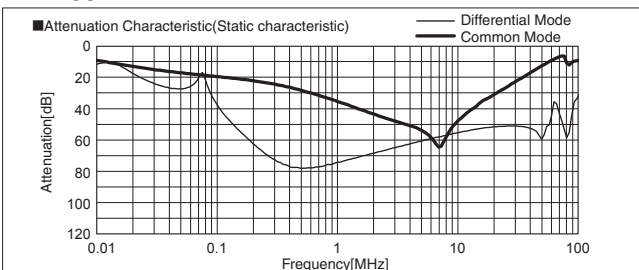

NAP-40-472

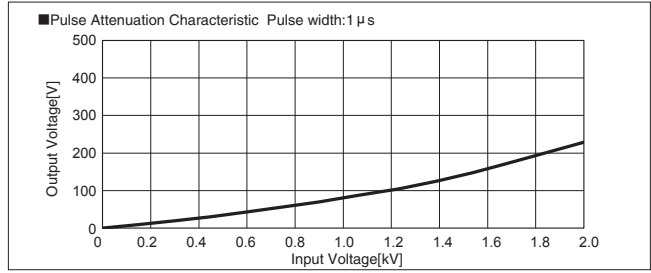
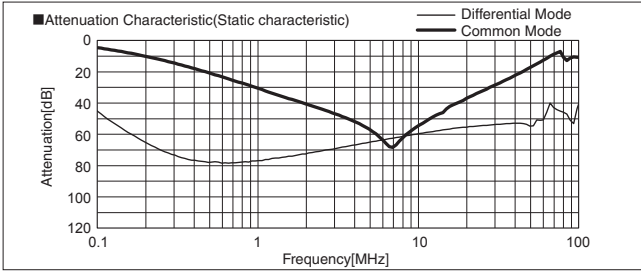

NAP-50-472

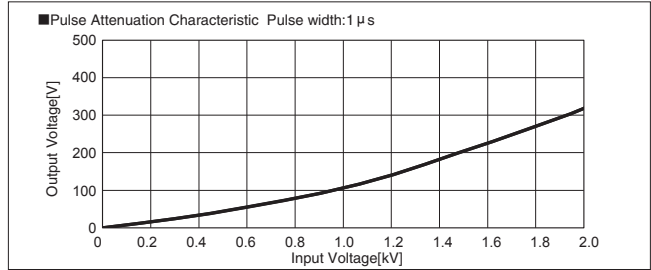
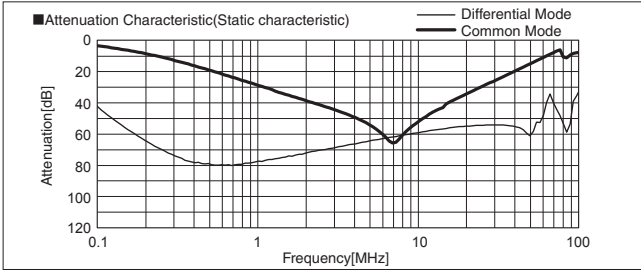

NAP-60-472

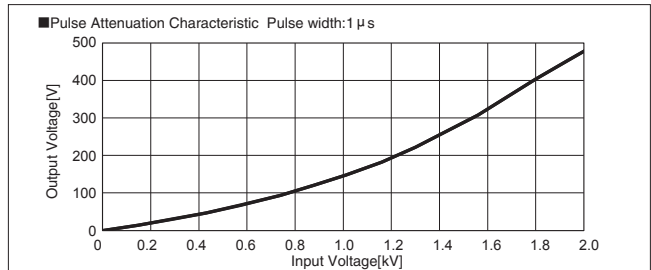
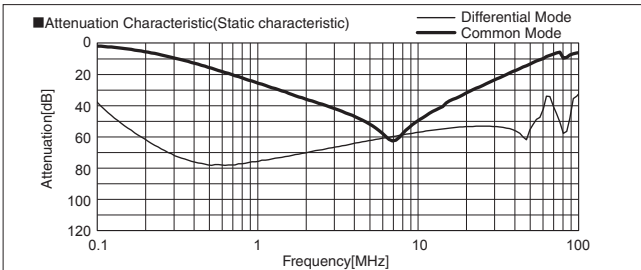

NAC-40-103-F

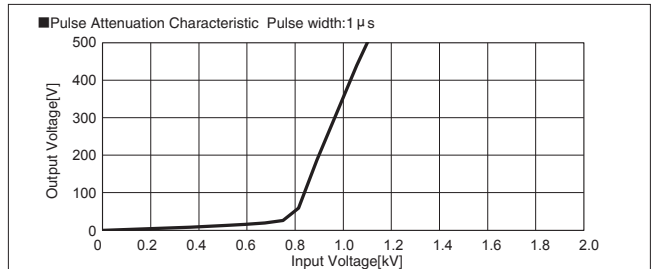
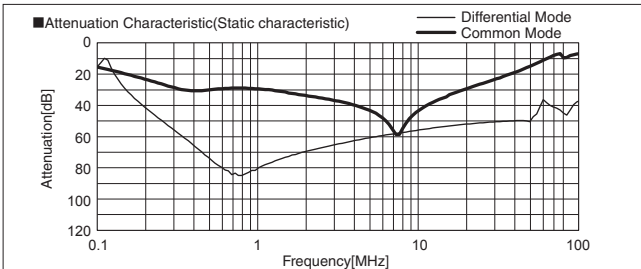

NAC-50-103-F

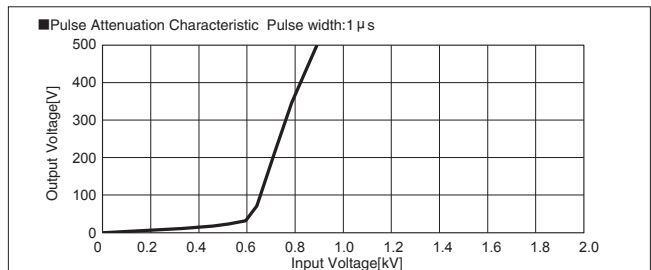
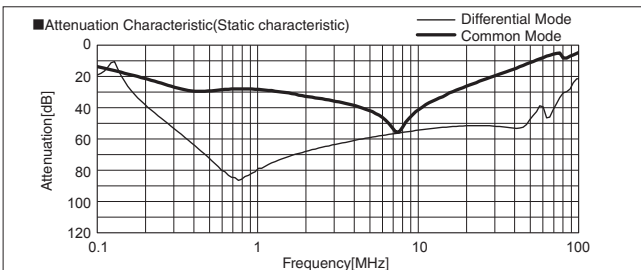

NAC-60-103-F

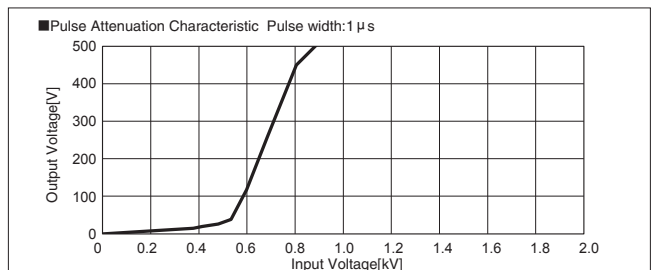
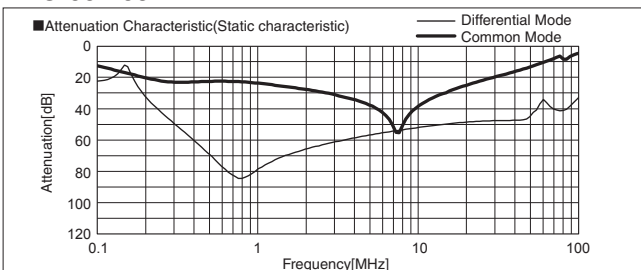

NAH-40-103-F

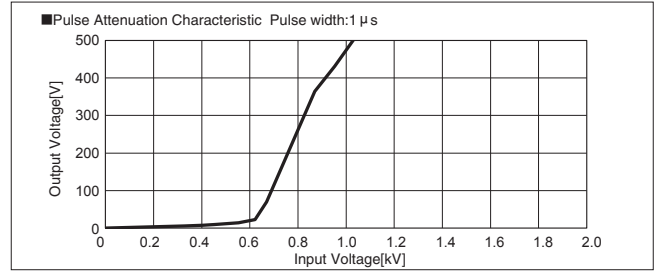
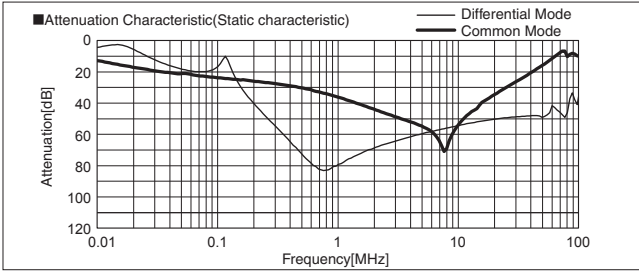

NAH-50-103-F

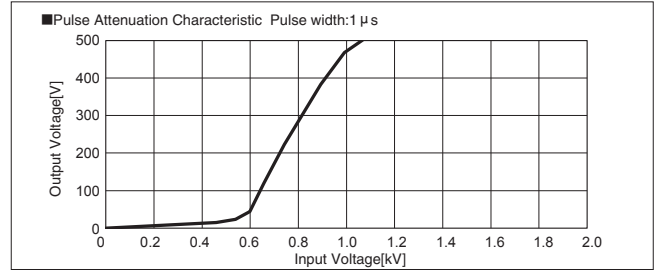
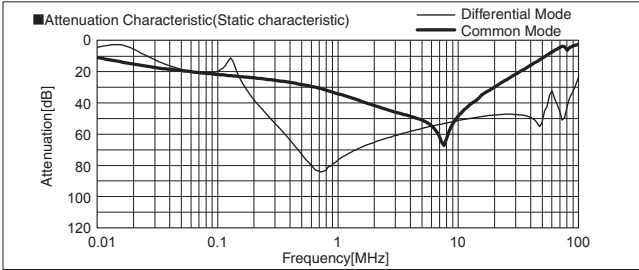

NAH-60-103-F

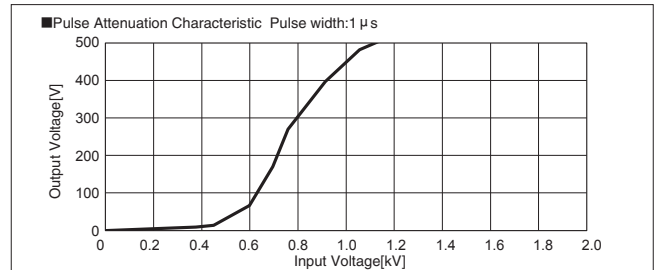
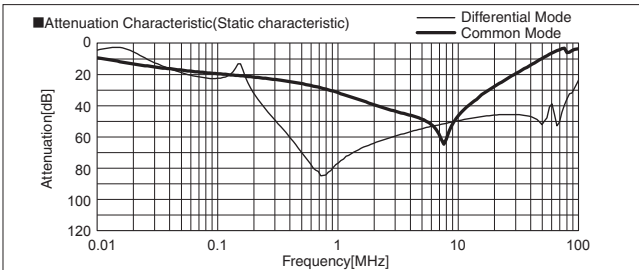

NAP-40-103-F

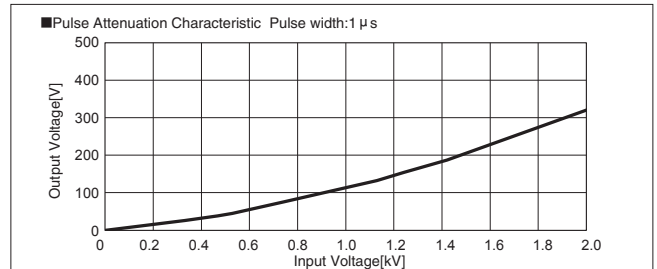
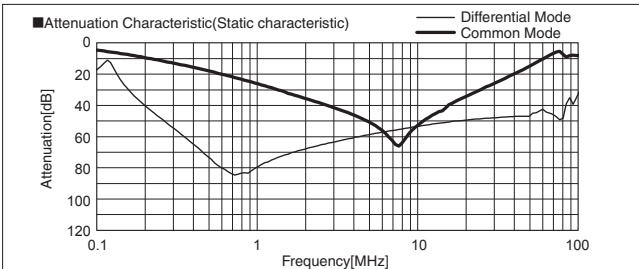

NAP-50-103-F

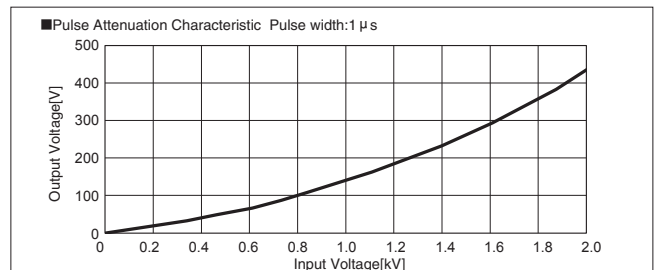
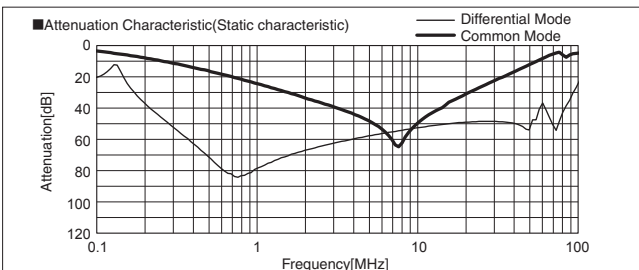

NAP-60-103-F

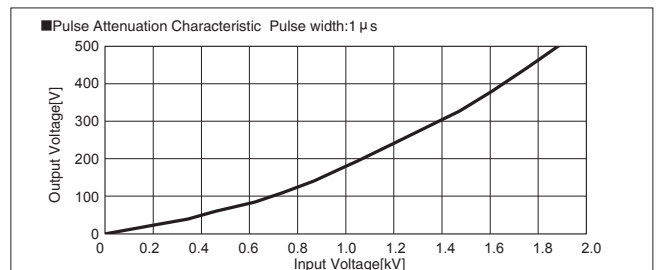
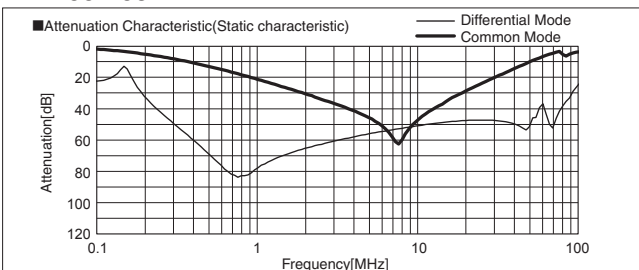

NBH series

NBH -10 -432 -□

① ② ③ ④

- ① Model Name
- ② Rated Current
- ③ Line to ground capacitor code: Refer to table 1.1.

table 1.1 Line to ground capacitor code

Code	Leakage Current (Input 125/250V 60Hz)	Line to ground capacitor (nominal value)		Test voltage (Terminal- Mounting Plate)
		CY1	CY2	
000	5 μ A/ 10 μ A max	Not Provided	Not Provided	4,000VAC
101	12.5 μ A/ 25 μ A max	100pF	Not Provided	
221	25 μ A/ 50 μ A max	220pF	Not Provided	
331	37.5 μ A/ 75 μ A max	330pF	Not Provided	
471	50 μ A/100 μ A max	470pF	Not Provided	
681	75.5 μ A/150 μ A max	680pF	Not Provided	2,500VAC
102	0.13mA/0.25mA max	1000pF	Not Provided	
202	0.25mA/0.5 mA max	1000pF	1000pF	
322	0.38mA/0.75mA max	2200pF	1000pF	
432	0.5 mA/1.0 mA max	3300pF	1000pF	

* When the line to ground capacitor code is different, the attenuation characteristic is different.

- ④ Option
- D: DIN rail installation type

* The dimensions change when the option is set.
Refer to External view.

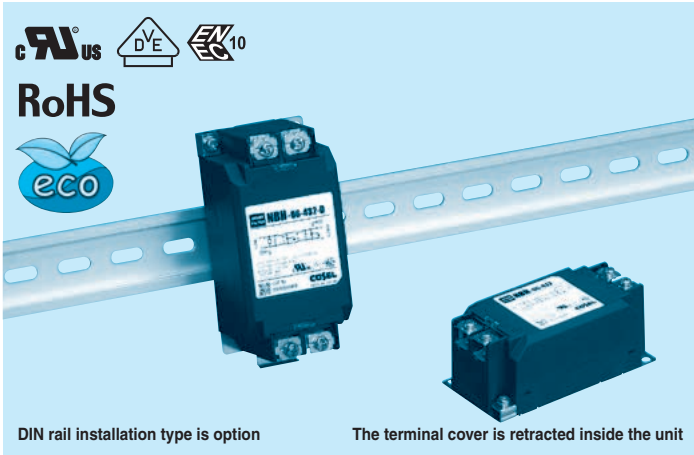

Features of NBH series

Ultra high-attenuation type from 9kHz to 10MHz (2-Stage filter)

- Single Phase 250VAC
- Withstand voltage 4,000 VAC (Line to ground capacitor code -000 to -471)
- Quick and easy push-down terminal

Just connect the wires, push-down and tighten the screws with a screwdriver

Specifications

No.	Items	NBH-06-432	NBH-10-432	NBH-16-432	NBH-20-432	NBH-30-432
1	Rated Voltage[V]	AC 1 ϕ 250 / DC250				
2	Rated Current[A]	6	10	16	20	30
3	Test Voltage (Terminal-Mounting Plate) *1	2,500 VAC (Cutoff Current = 20mA), 1minute at room temperature and humidity				
4	Isolation Resistance (Terminal-Mounting Plate)	500 VDC 100M Ω min at room temperature and humidity				
5	Leakage current 125/250V 60Hz	0.5mA/1.0mA max				
6	Voltage drop	1.0V max				
7	Safety agency approval temperatures	-25 to +85°C (Refer to Derating Curve A)		-25 to +85°C (Refer to Derating Curve B)		
8	Operating temperature	-40 to +85°C (Refer to Derating Curve A)		-40 to +85°C (Refer to Derating Curve B)		
9	Operating humidity	20 to 95%RH (Non condensing)				
10	Storage temperature/humidity	-40 to +85°C/20 to 95%RH (Non condensing)				
11	Vibration	10 to 55Hz, 19.6m/s ² (2G), 3min. Period, 1hour each X, Y and Z axis				
12	Impact	196.1m/s ² (20G), 11ms Once each X, Y and Z axis				
13	Safety agency approvals	UL1283, CSA C22.2 No.8 (C-UL), DIN EN60939 VDE0565 Teil3-1, ENEC (At only AC input)				
14	Case size (without projection) /Weight	53X43X104 mm [2.09X1.69X4.09 inches] (W X H X D) /320g max (Option : -D refer to external view)				

*1 When the line to ground capacitor code is different, the test voltage characteristic is different. (Refer to table 1.1)

Circuit Diagram

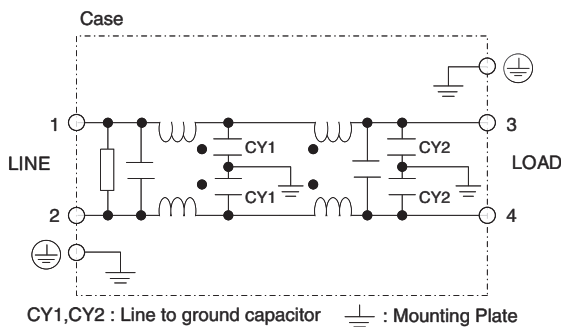

Derating Curve

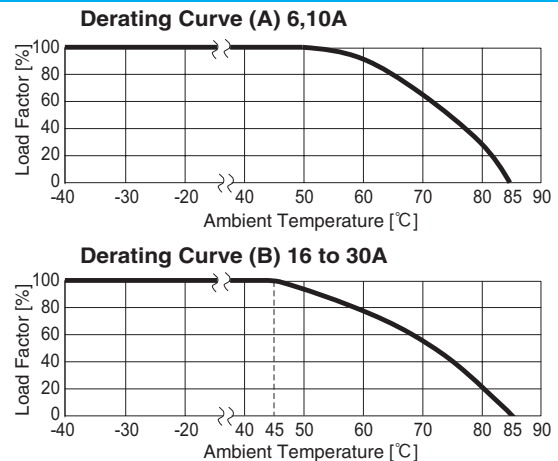

External view

This product is shipped in the following condition, because it is equipped with push-down terminals.

- ① The terminal cover is retracted inside the unit.
- ② The screws for connecting the terminals are held in the up right position.

Standard Type

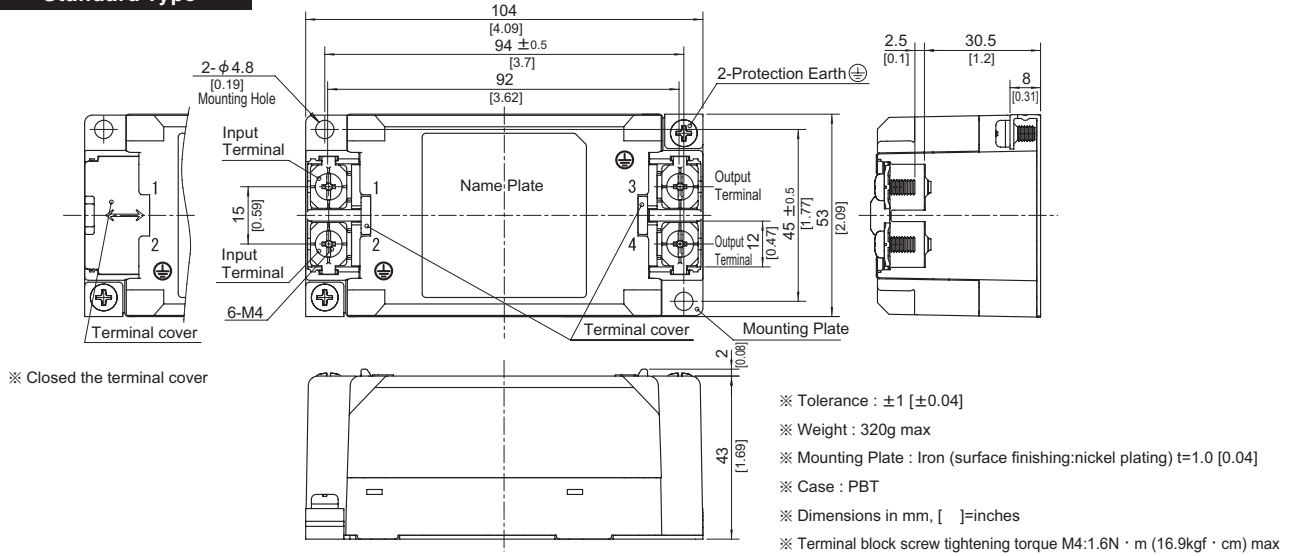

※ Closed the terminal cover

DIN rail installation Type

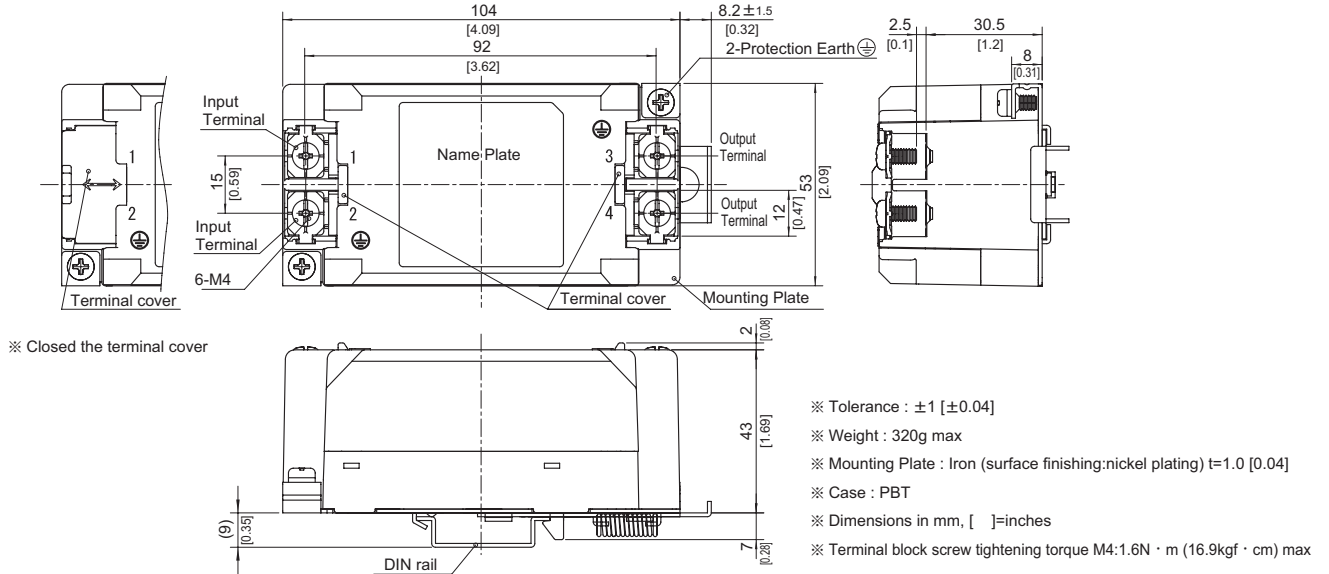

※ Closed the terminal cover

■ Note when installing the EMI/EMC Filter on a DIN rail.

When the EMI/EMC Filter is grounded through the DIN rail, the proper noise attenuation may not be achieved.

Be sure to connect the protection earth (PE) of the EMI/EMC Filter body to the earth. At least one PE connection is required.

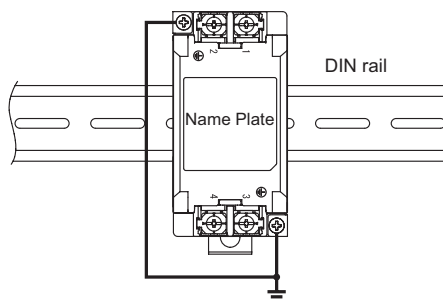

NBC/NBM series

NBC -10 -472 -□

① ② ③ ④

- ① Series Name
- ② Rated Current
- ③ Line to ground capacitor code: Refer to table 1.1.

table.1.1 Line to ground capacitor code

Code	NBC	NBM	Leakage Current (Input 125/250V 60Hz)	Line to ground capacitor (nominal value)
000			5 μ A / 10 μ A max	Not Provided
101	●		12.5 μ A / 25 μ A max	100pF
221	●		25 μ A / 50 μ A max	220pF
331	●		37.5 μ A / 75 μ A max	330pF
471	●		50 μ A / 100 μ A max	470pF
681	●		75.5 μ A / 150 μ A max	680pF
102	●		0.13 mA / 0.25mA max	1,000pF
222	●		0.25 mA / 0.5 mA max	2,200pF
332	●		0.38 mA / 0.75mA max	3,300pF
472	●		0.5 mA / 1.0 mA max	4,700pF

* When the line to ground capacitor code is different, the attenuation characteristic is different.

- ④ Option
- D: DIN rail installation type

* The dimensions change when the option is set. Refer to External view.

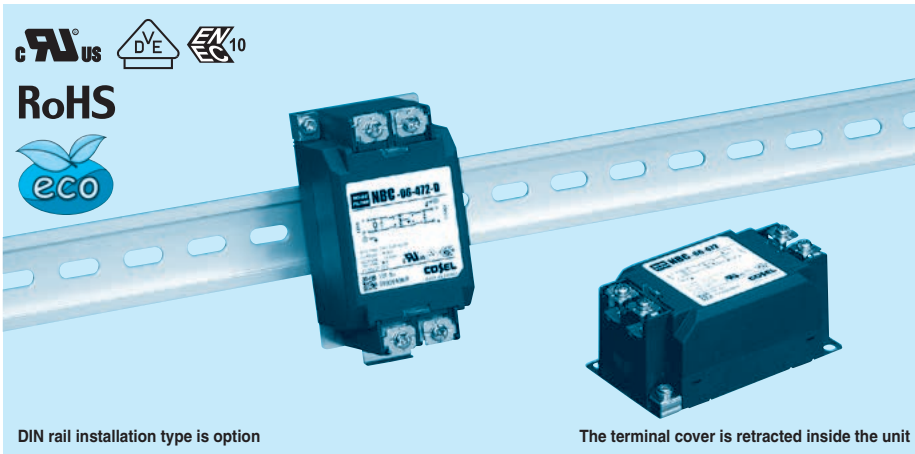

DIN rail installation type is option

The terminal cover is retracted inside the unit

Features of NBC/NBM series

- Single Phase 250VAC (2-Stage filter)
 - Quick and easy push-down terminal
- Just connect the wires, push-down and tighten the screws with a screwdriver

- NBC : High-attenuation type from 150kHz to 1MHz
- NBM : Low leakage current, Withstand voltage 4,000 VAC

Specifications

No.	Items	NBC-06-472	NBC-10-472	NBC-16-472	NBC-20-472	NBC-30-472
		NBM-06-471	NBM-10-471	NBM-16-471	NBM-20-471	NBM-30-471
1	Rated Voltage[V]	AC 1 ϕ 250 / DC250				
2	Rated Current[A]	6	10	16	20	30
3	Test Voltage (Terminal-Mounting Plate)	NBC : 2,500 VAC (Cutoff Current = 20mA), 1minute at room temperature and humidity NBM : 4,000 VAC (Cutoff Current = 20mA), 1minute at room temperature and humidity				
4	Isolation Resistance (Terminal-Mounting Plate)	500 VDC 100M Ω min at room temperature and humidity				
5	Leakage current	Refer to table 1.1				
6	Voltage drop	1.0V max				
7	Safety agency approval temperatures	-25 to +85 $^{\circ}$ C (Refer to Derating Curve)				
8	Operating temperature	-40 to +85 $^{\circ}$ C (Refer to Derating Curve)				
9	Operating humidity	20 to 95%RH (Non condensing)				
10	Storage temperature/humidity	-40 to +85 $^{\circ}$ C/20 to 95%RH (Non condensing)				
11	Vibration	10 to 55Hz, 19.6m/s 2 (2G), 3min. Period, 1hour each X, Y and Z axis				
12	Impact	196.1m/s 2 (20G), 11ms Once each X, Y and Z axis				
13	Safety agency approvals	UL1283, CSA C22.2 No.8 (C-UL), DIN EN60939 VDE0565 Teil3-1, ENEC (At only AC input)				
14	Case size (without projection) /Weight	53X41X92 mm [2.09X1.61X3.62 inches] (W X H X D) /270g max (Option : -D refer to external view)				

Circuit Diagram

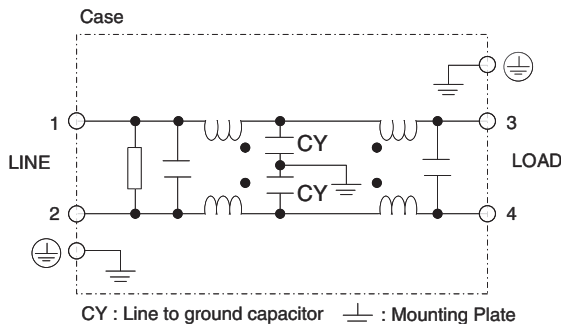

Derating Curve

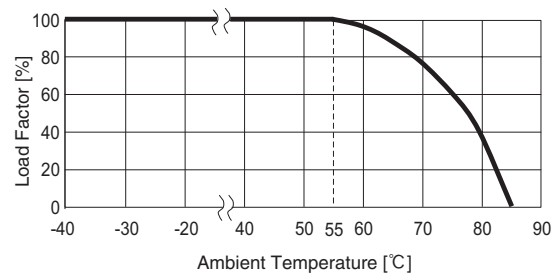

External view

This product is shipped in the following condition, because it is equipped with push-down terminals.

- ① The terminal cover is retracted inside the unit.
- ② The screws for connecting the terminals are held in the up right position.

Standard Type

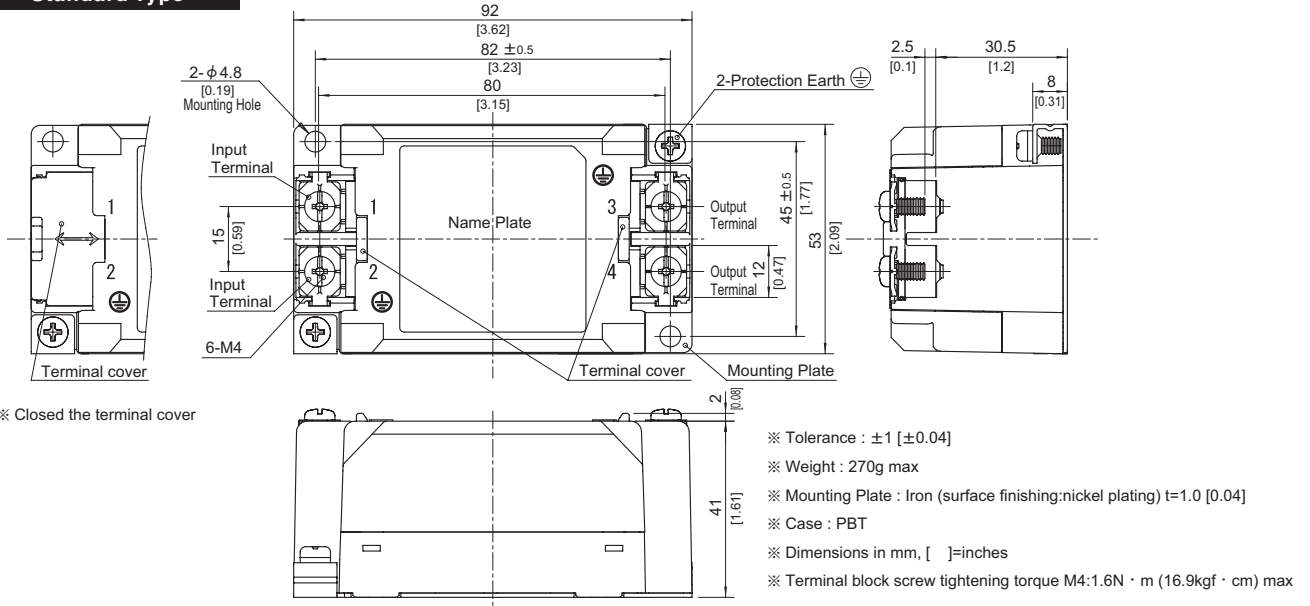

DIN rail installation Type

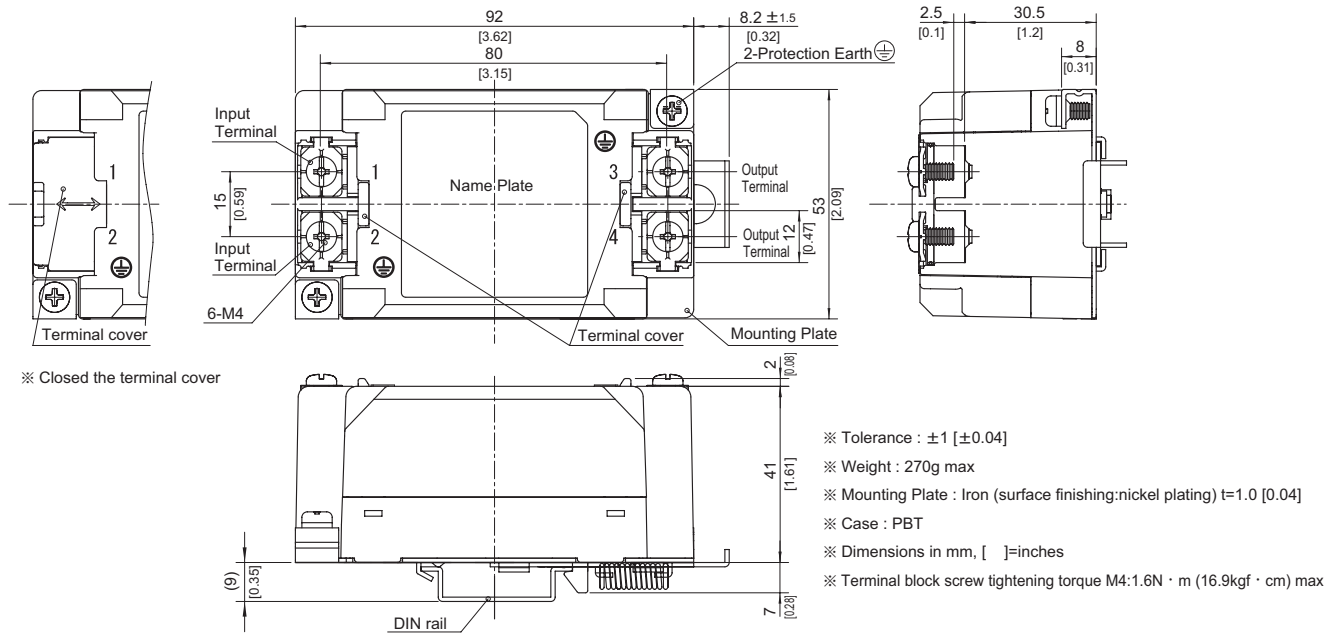

■ Note when installing the EMI/EMC Filter on a DIN rail.

When the EMI/EMC Filter is grounded through the DIN rail, the proper noise attenuation may not be achieved.

Be sure to connect the protection earth (PE) of the EMI/EMC Filter body to the earth. At least one PE connection is required.

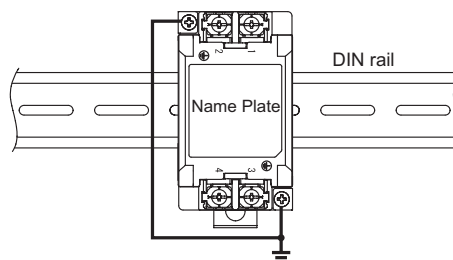

NBH-06-432

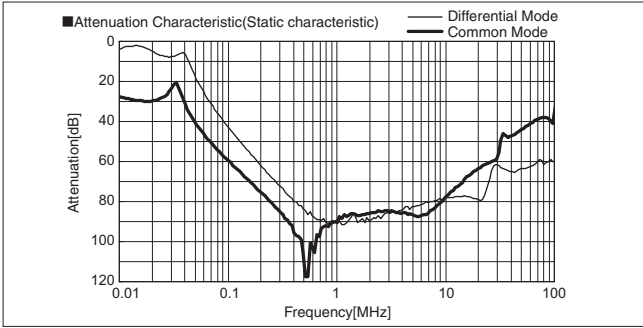

NBH-10-432

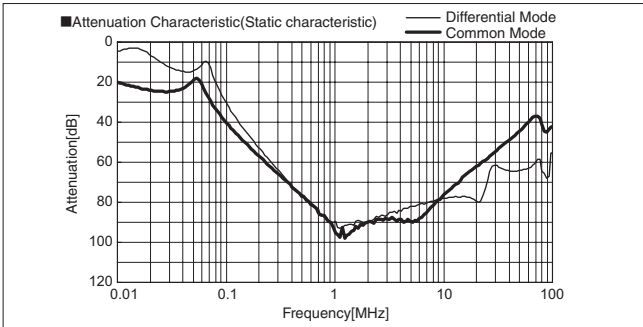

NBH-16-432

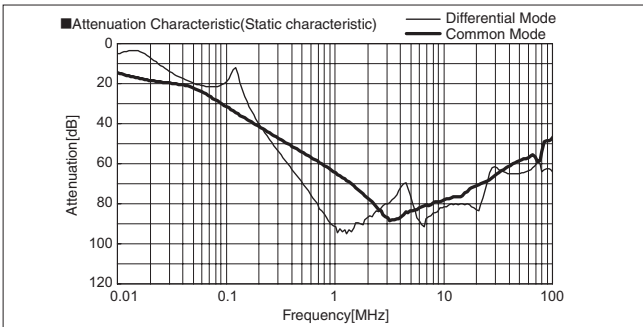

NBH-20-432

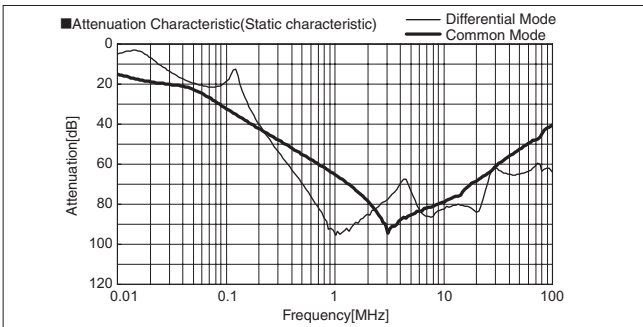

NBH-30-432

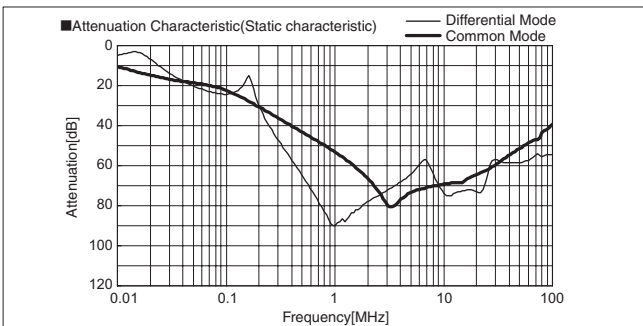

NBC-06-472

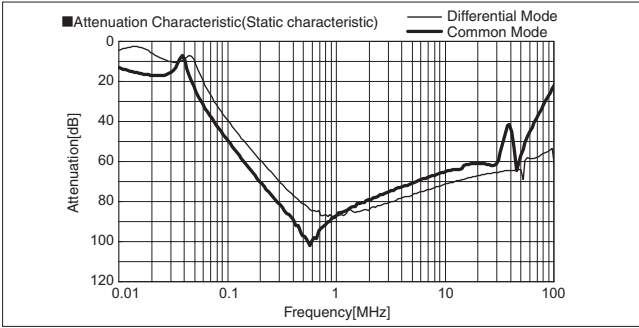

NBM-06-471

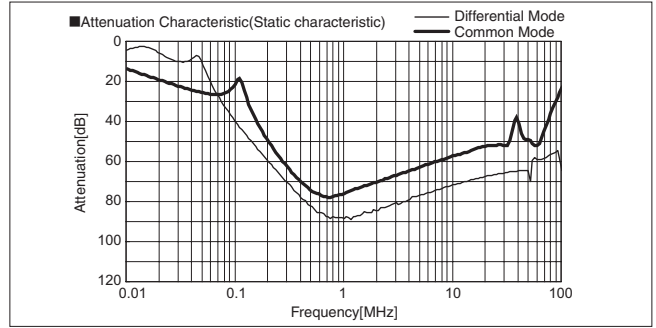

NBC-10-472

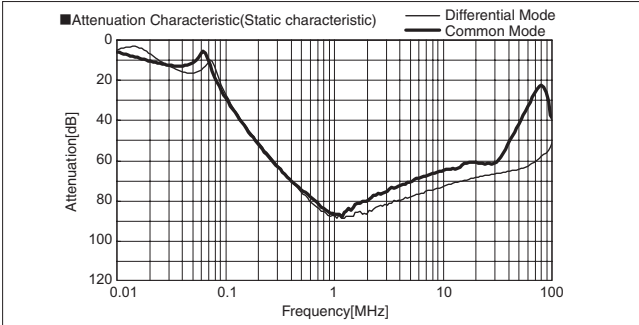

NBM-10-471

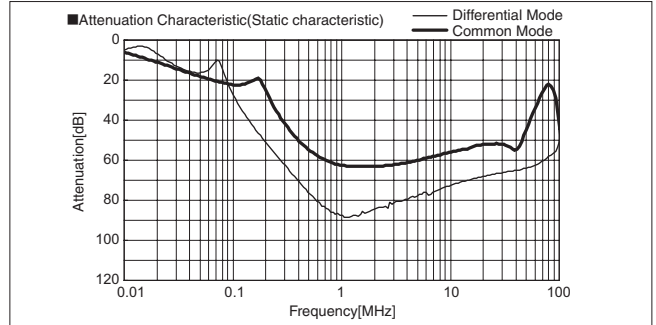

NBC-16-472

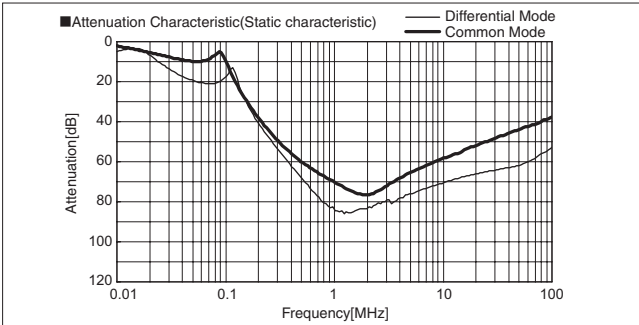

NBM-16-471

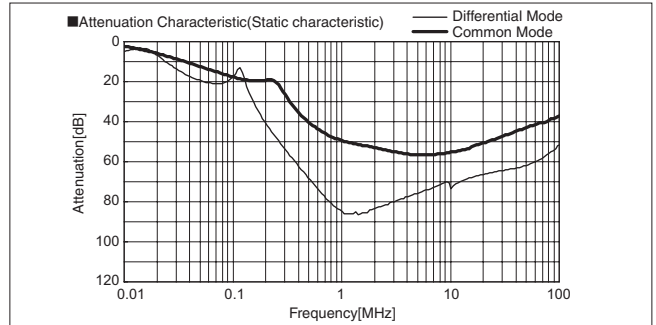

NBC-20-472

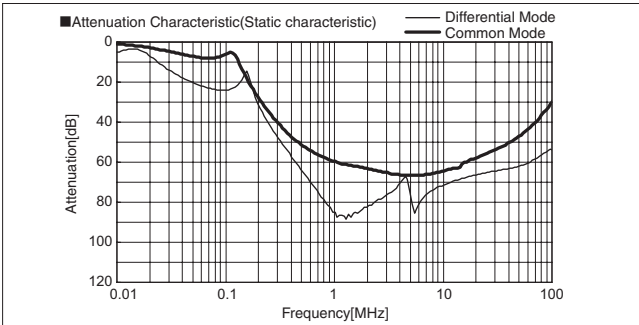

NBM-20-471

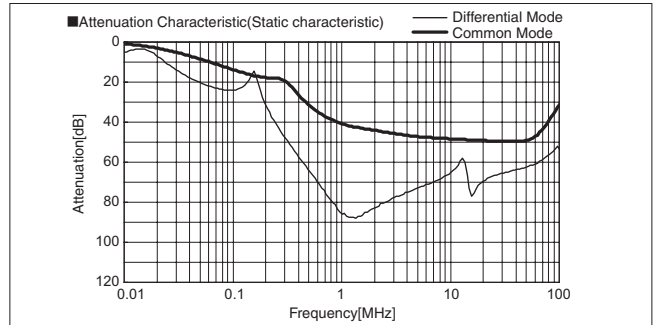

NBC-30-472

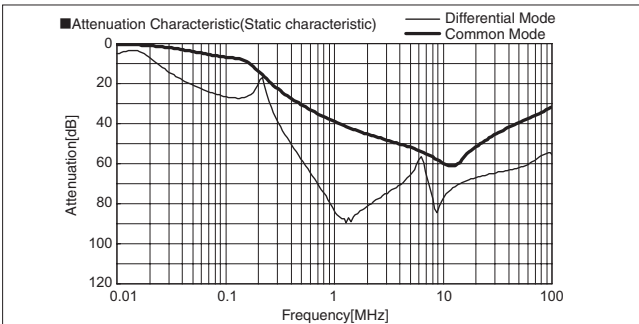

NBM-30-471

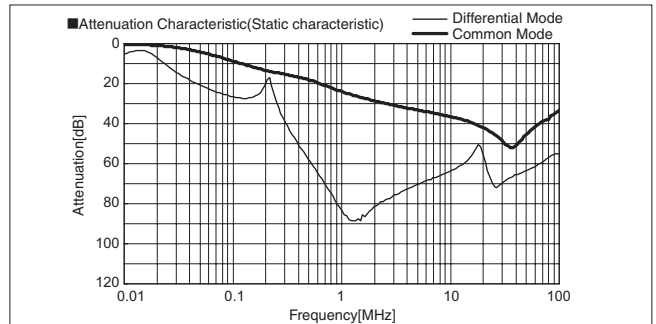

JAC series(6-30A)

JAC -30 -683 -□

① ② ③ ④

- ① Model Name
- ② Rated Current
- ③ Line to ground capacitor code: See table 1.1.

table 1.1 Line to ground capacitor code

Code	Leakage Current (Input 250/500V 60Hz) (Only "224" is 250/400V 60Hz)	Line to ground capacitor (nominal value)
103	0.5mA / 1.0mA max	10,000pF
223	1.0mA / 2.0mA max	22,000pF
683	2.5mA / 5.0mA max	68,000pF
224	15mA / 24mA max	220,000pF

* When the line to ground capacitor code is different, the attenuation characteristic is different.

- ④ Option
- D: DIN rail installation type
* The dimensions change when the option is set. Refer to External view.
- H: Ultra high-attenuation type
"103", "223", "683" is applied.
- U: Improve differential mode attenuation (Rated voltage 250V)

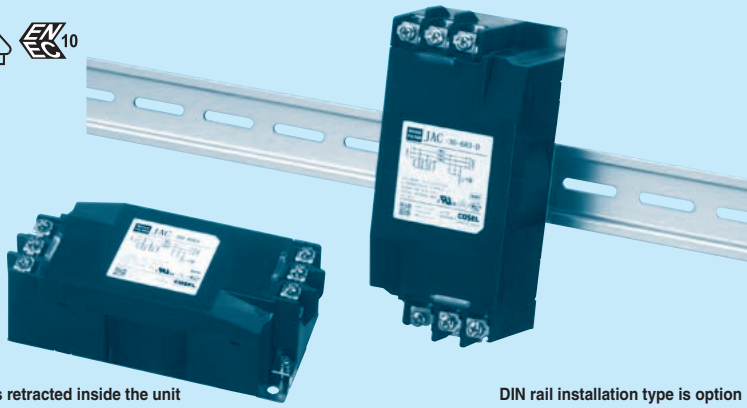

The terminal cover is retracted inside the unit

DIN rail installation type is option

Features of JAC series

Compact and low profile, common mode EMI/EMC filters in 150kHz to 1MHz (1-stage filter)

- Three Phase 500 VAC
- Push down type terminal block
- Selectable leakage current value, Ultra high-attenuation type "224" for EU (Y type with neutral earth system)

Specifications

No.	Items	JAC-06-683	JAC-10-683	JAC-20-683	JAC-30-683
1	Rated Voltage[V]	AC Three Phase 500 (voltage range:528 max) 50/60Hz *1 *2			
2	Rated Current[A]	6	10	20	30
3	Test Voltage (Terminal-Mounting Plate)	2,500 VAC (Cutoff Current = 100mA), 1minute at room temperature and humidity *3			
4	Isolation Resistance (Terminal-Mounting Plate)	500 VDC 100MΩ min at room temperature and humidity *4			
5	Leakage current 250/500V 60Hz	2.5mA/5.0mA max			
6	DC resistance	100mΩ max	45mΩ max	15mΩ max	8mΩ max
7	Safety agency approval temperatures	-25 to +85°C (Refer to Derating Curve)			
8	Operating temperature	-40 to +85°C (Refer to Derating Curve)			
9	Operating humidity	20 to 95%RH (Non condensing)			
10	Storage temperature/humidity	-40 to +85°C/20 to 95%RH (Non condensing)			
11	Vibration	10 to 55Hz, 19.6m/s ² (2G), 3min. Period, 1hour each X, Y and Z axis			
12	Impact	196.1m/s ² (20G), 11ms Once each X, Y and Z axis			
13	Safety agency approvals	UL1283, CSA C22.2 No.8 (C-UL), DIN EN60939 VDE0565 Teil3-1, ENEC			
14	Case size (without projection)	63 X 44 X 132 mm (W X H X D) (Option: -D refer to external view)			
15	Weight	440g max			

- *1 Capacitor code "224" : Three Phase Δ-connection 400 (440 max), Y-connection 500 (528 max).
- *2 "JAC-□□□□□□□□□□-U" : Three Phase 250 (275 max).
- *3 Capacitor code "224" : 2,800VDC (Cutoff Current = 10mA), 1 minute at room temperature and humidity.
- *4 Capacitor code "224" : Isolation resistance specification is deleted.

Circuit Diagram

(1) Line to ground capacitor code : 103, 223, 683

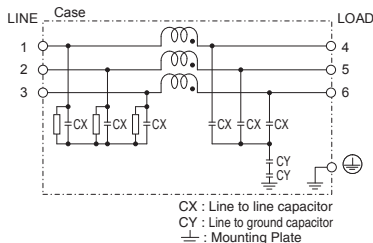

(2) Line to ground capacitor code : 224

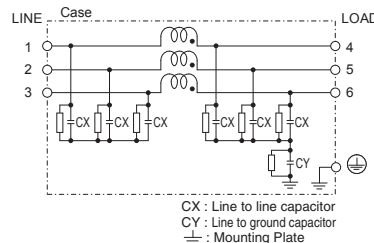

(3) Line to ground capacitor code : 103, 223, 683
Option : U

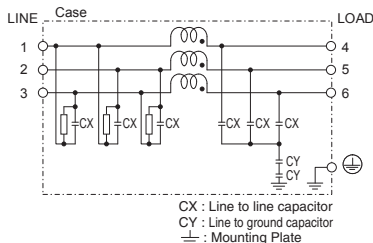

(4) Line to ground capacitor code : 224
Option : U

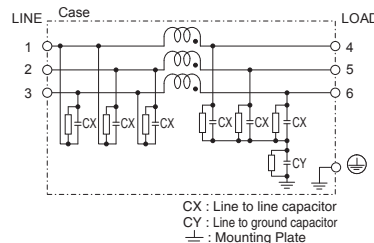

Derating Curve

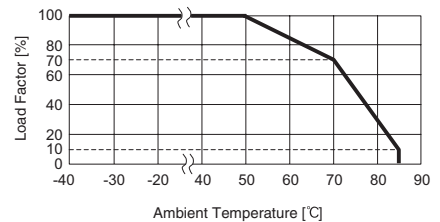

External view

This product is shipped in the following condition, because it is equipped with push-down terminals.

- ① The terminal cover is retracted inside the unit.
- ② The screws for connecting the terminals are held in the up right position.

Standard Type

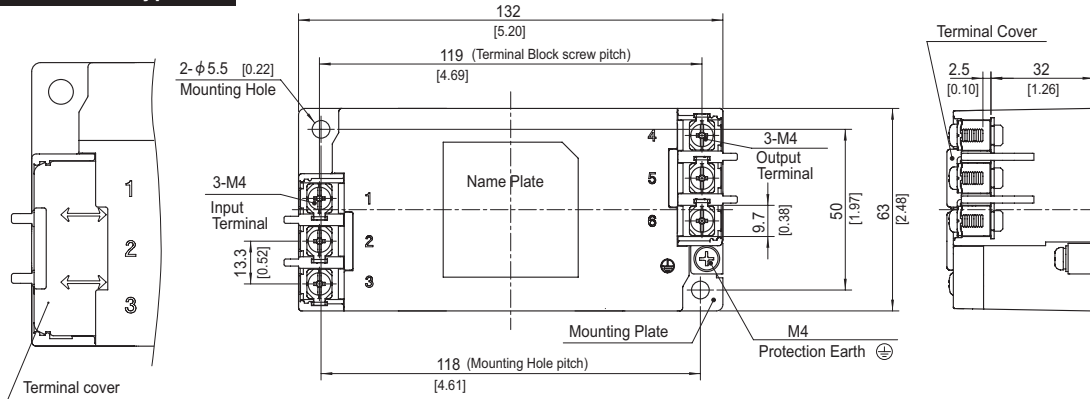

※ Close the terminal cover

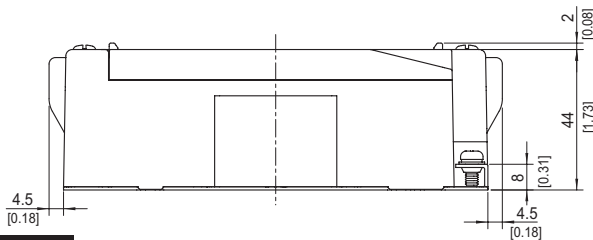

- ※ Tolerance : $\pm 1[\pm 0.04]$
- ※ Weight : 440g max
- ※ Mounting Plate : Iron(surface finishing : nickel plating) $t=1.0[0.04]$
- ※ Case : PBT
- ※ Dimensions in mm, []=inches
- ※ Terminal block screw tightening torque M4 : $1.6N \cdot m(16.9kgf \cdot cm)$ max

DIN rail installation Type

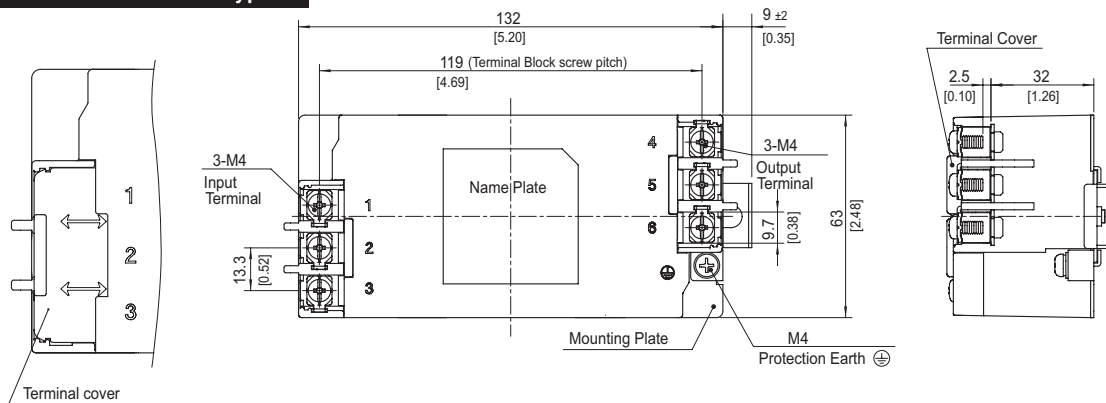

※ Close the terminal cover

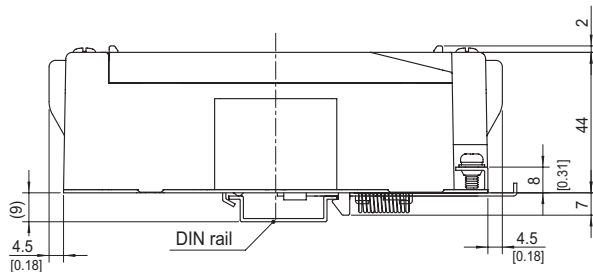

- ※ Tolerance : $\pm 1[\pm 0.04]$
- ※ Weight : 440g max
- ※ Mounting Plate : Iron(surface finishing : nickel plating) $t=1.0[0.04]$
- ※ Case : PBT
- ※ Dimensions in mm, []=inches
- ※ Terminal block screw tightening torque M4 : $1.6N \cdot m(16.9kgf \cdot cm)$ max

■ Note when installing the EMI/ EMC Filter on a DIN rail.

When the EMI/EMC Filter is grounded through the DIN rail, the proper noise attenuation may not be achieved.

Be sure to connect the protection earth (PE) of the EMI/EMC Filter body to the earth.

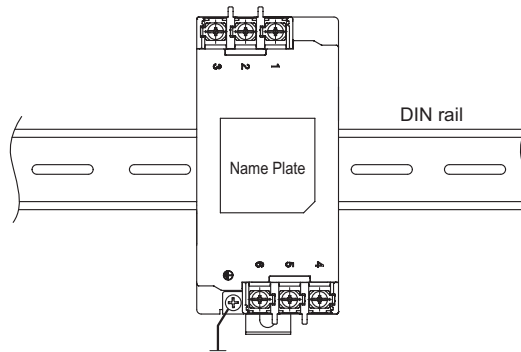

JAC-06-103

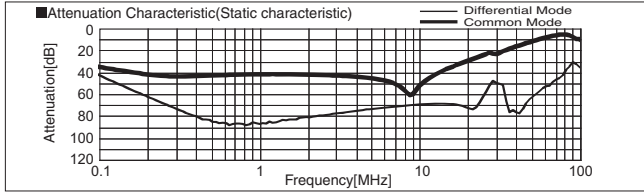

JAC-06-223

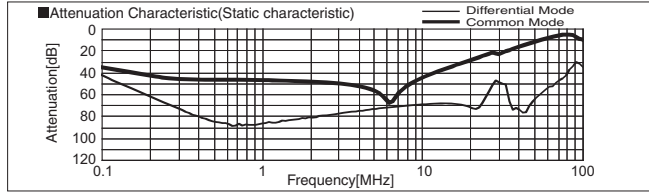

JAC-06-683

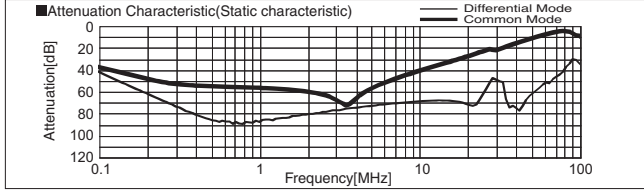

JAC-06-224

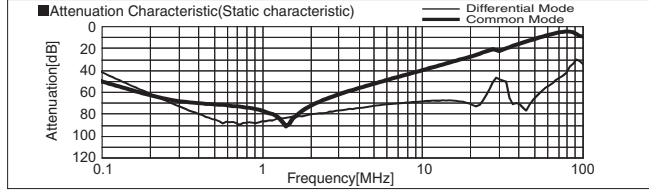

JAC-10-103

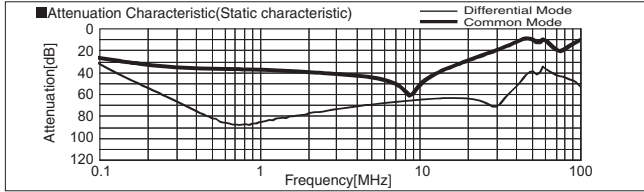

JAC-10-223

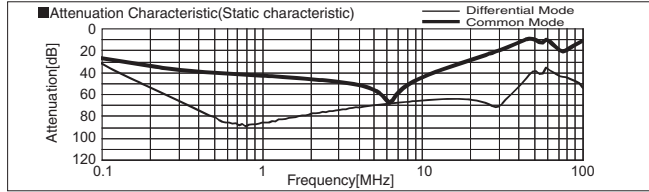

JAC-10-683

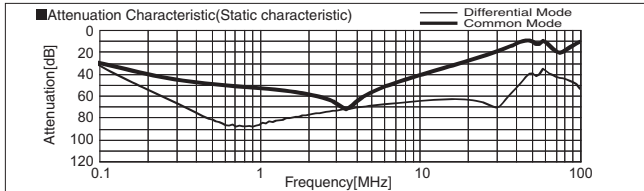

JAC-10-224

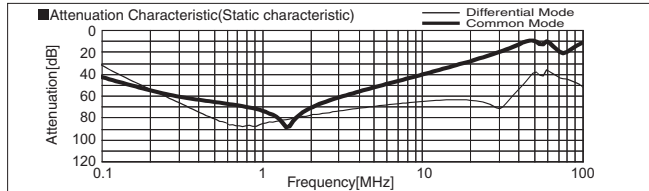

JAC-20-103

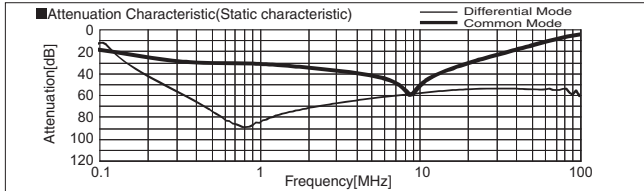

JAC-20-223

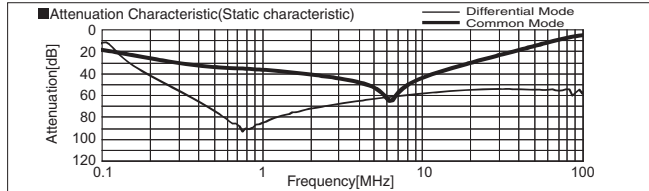

JAC-20-683

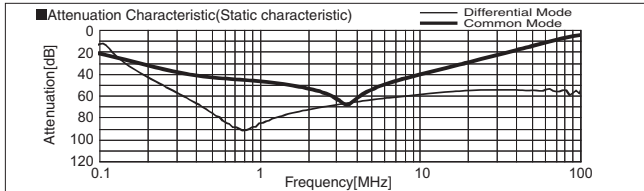

JAC-20-224

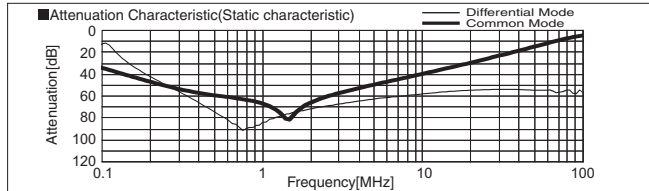

JAC-30-103

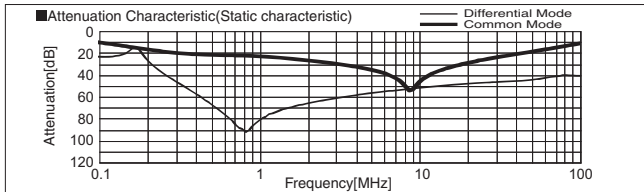

JAC-30-223

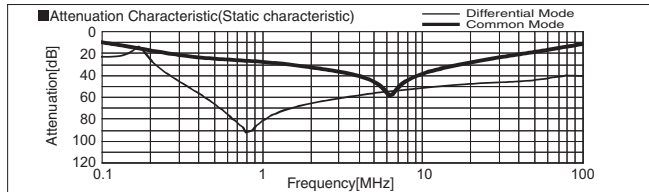

JAC-30-683

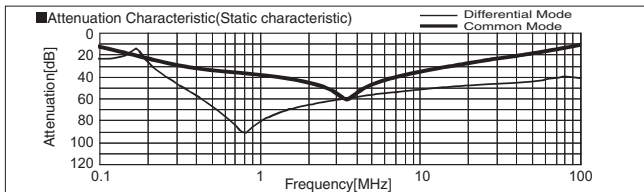

JAC-30-224

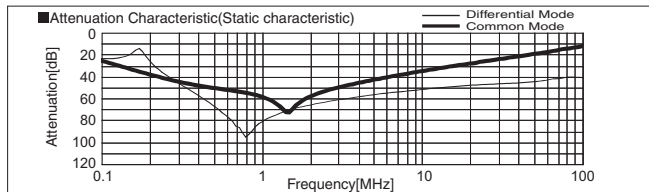

JAC series(40,50,60A)

JAC -50 -683 -□

① ② ③ ④

- ① Series Name
- ② Rated Current
- ③ Line to ground capacitor code: See table 1.1.

table 1.1 Line to ground capacitor code

Code	Leakage Current *1 Upper row : Δ-connection Lower row : Y-connection	Line to ground capacitor (nominal value)
103	0.5mA / 1.0mA max 0.05mA / 0.1mA max	0.01μF
223	1.0mA / 2.0mA max 0.1mA / 0.2mA max	0.022μF
683	2.5mA / 5.0mA max 0.35mA / 0.7mA max	0.068μF
224	15mA / 24mA max 2.0mA / 4.0mA max	0.22μF
155	80mA / 125mA max 9.0mA / 18mA max	1.5μF

* When the line to ground capacitor code is different, the attenuation characteristic is different.

*1 Input 250/500V 60Hz
(Δ-connection of "224", "155" is 250/400V 60Hz)

- ④ Option
- H: Ultra high-attenuation type
"103", "223", "683" is applied.
- U: Improve differential mode attenuation
(Rated voltage 250V)



Features of JAC series

Compact and low profile, common mode EMI/EMC filters in 150kHz to 1MHz (1-stage filter)

- Three phase rated voltage 500 VAC (voltage range : 528V max)
- Selectable leakage current value, Ultra high-attenuation type "224", "155" for EU (Y type with neutral earth system)

Specifications

No.	Items	JAC-40-683	JAC-50-683	JAC-60-683
1	Rated Voltage[V]	AC Three Phase 500 (voltage range: 528 max) 50/60Hz *2 *3		
2	Rated Current[A]	40	50	60
3	Test Voltage (Terminal-Mounting Plate)	2,500 VAC (Cutoff Current = 100mA), 1minute at room temperature and humidity *4		
4	Isolation Resistance (Terminal-Mounting Plate)	500 VDC 100MΩ min at room temperature and humidity *5		
5	Leakage current 250/500V 60Hz	2.5mA/5.0mA max		
6	DC resistance	7.0mΩ max	5.0mΩ max	3.5mΩ max
7	Safety agency approval temperatures	-40 to +85°C (Refer to Derating Curve)		
8	Operating temperature	-40 to +85°C (Refer to Derating Curve)		
9	Operating humidity	20 to 95%RH (Non condensing)		
10	Storage temperature/humidity	-40 to +85°C/20 to 95%RH (Non condensing)		
11	Vibration	10 to 55Hz, 19.6m/s ² (2G), 3min. Period, 1hour each X, Y and Z axis		
12	Impact	196.1m/s ² (20G), 11ms Once each X, Y and Z axis		
13	Safety agency approvals	UL60939[Overvoltage Category : III Altitude : 3000m], CSA C22.2 No.8 (C-UL) EN60939[DEMKO][Overvoltage Category: III Altitude: 3000m] , ENEC		
14	Case size (without projection)	65 X 54 X 153 mm (W X H X D) [2.56 X 2.13 X 6.02 inches] (W X H X D)		
15	Weight	800g max		

*2 Capacitor code "224" and "155" : Three Phase Δ-connection 400 (440 max), Y-connection 500 (528 max).

*3 "JAC-□□□□□□□□-U" : Three Phase 250 (275 max).

*4 Capacitor code "224" and "155" : 2,800VDC (Cutoff Current = 10mA), 1 minute at room temperature and humidity.

*5 Capacitor code "224" and "155" : Isolation resistance specification is deleted.

Circuit Diagram

(1) Line to ground capacitor code : 103, 223, 683

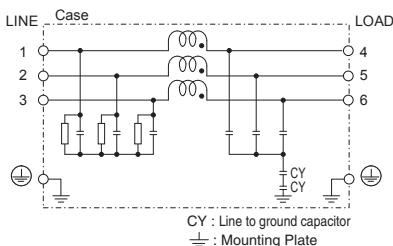

(2) Line to ground capacitor code : 224, 155

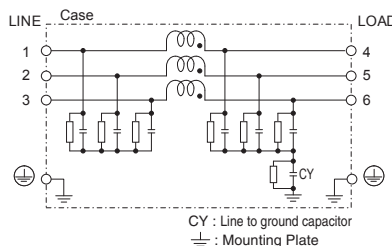

(3) Line to ground capacitor code : 103, 223, 683
Option : U

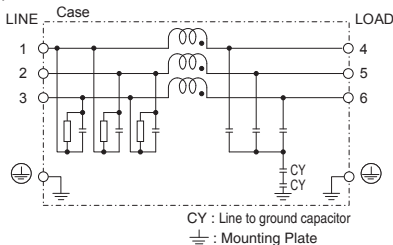

(4) Line to ground capacitor code : 224, 155
Option : U

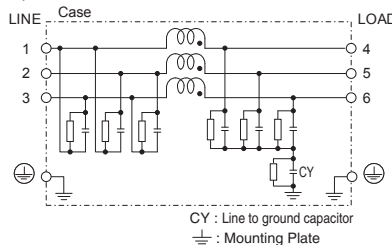

Derating Curve

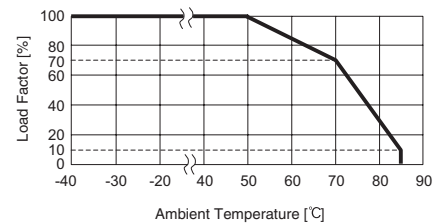

* Keep free ventilation holes for cooling.

External view

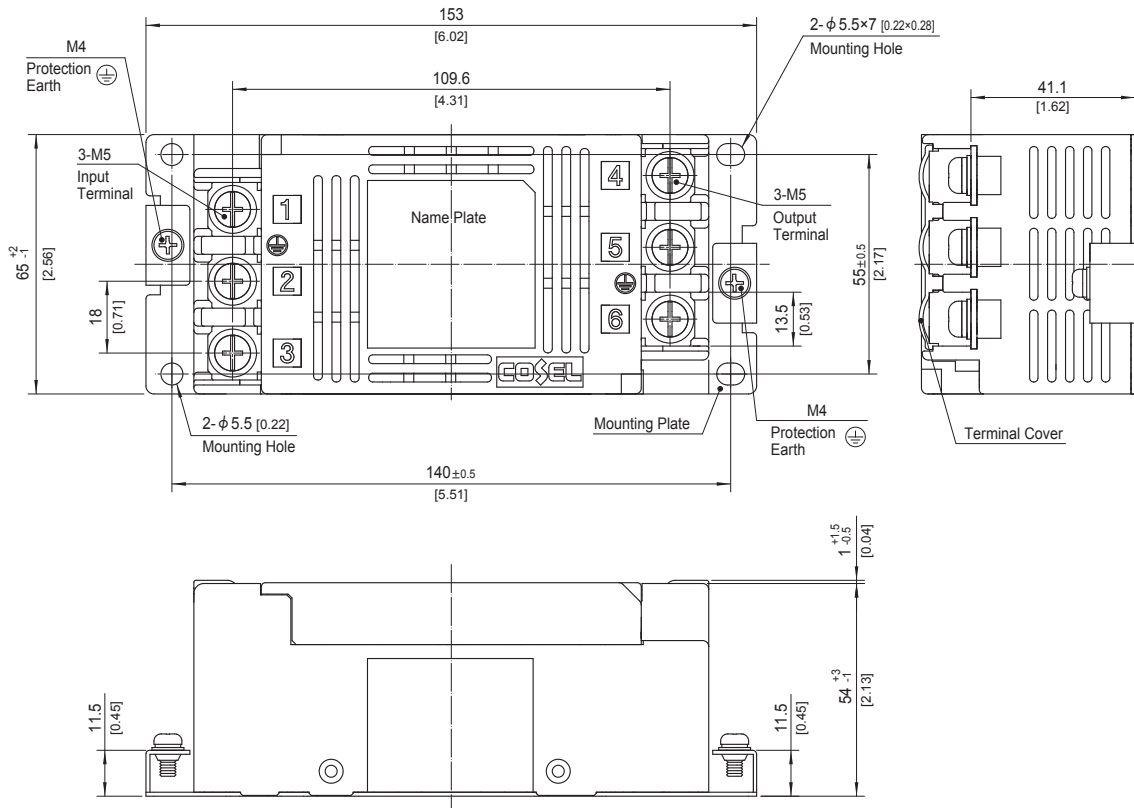

- ※ Tolerance : ±1 [±0.04]
- ※ Weight : 800g max
- ※ Mounting Plate : Hot-dip Galvanized Steel board t =1.0 [0.04]
- ※ Case Material : PBT
- ※ Dimensions in mm, []=inches
- ※ Terminal block screw tightening torque M5 : 3.0N · m (30.7kgf · cm) max
- ※ Protection Earth (PE) screw tightening torque M4 : 1.6N · m (16.9kgf · cm) max
- ※ Can not be mounted upside-down. (mounted the top surface)
- ※ Keep free ventilation holes for cooling.
- ※ Can be mounted using the 2 corner mounting holes.

JAC-40-103-H

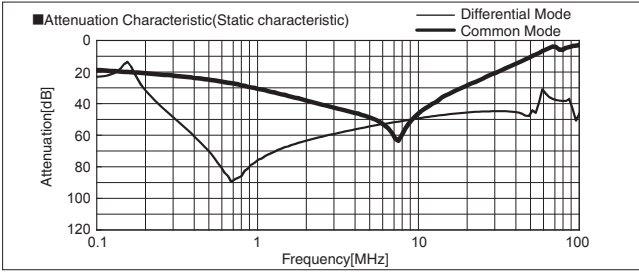

JAC-40-223-H

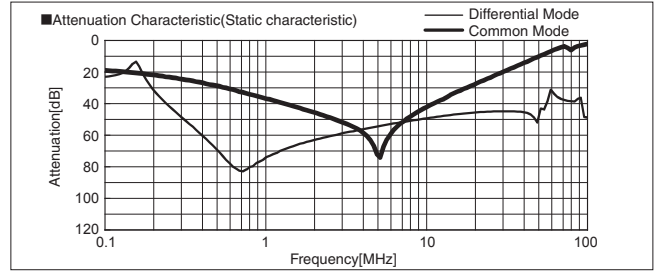

JAC-40-683-H

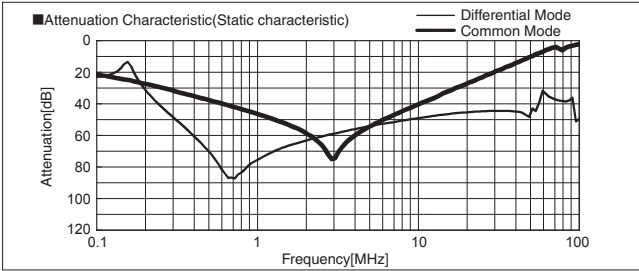

JAC-50-103-H

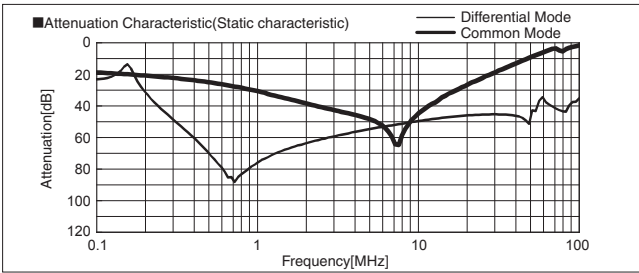

JAC-50-223-H

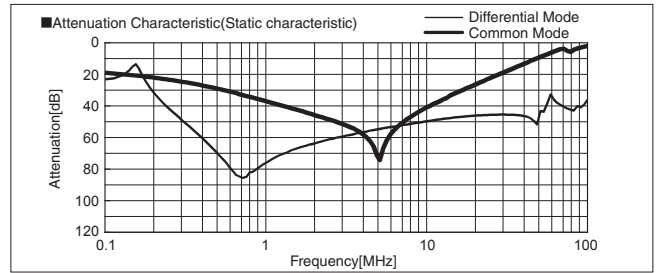

JAC-50-683-H

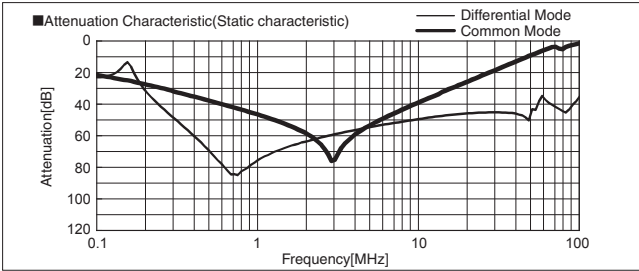

JAC-60-103-H

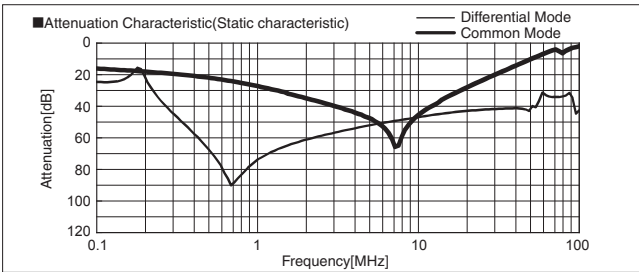

JAC-60-223-H

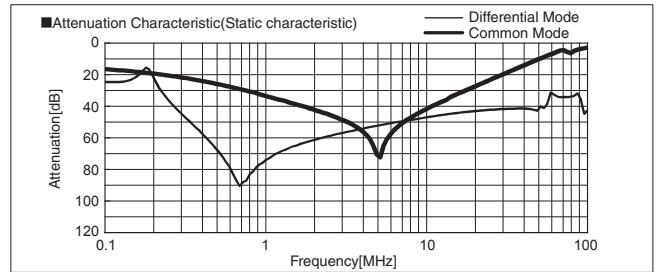

JAC-60-683-H

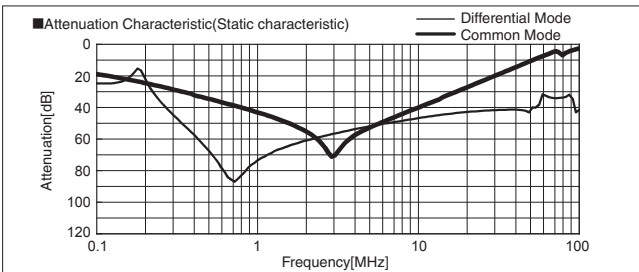

TAC/TAH series (4-30A)

TAC -10 -683 -□

① ② ③ ④

- ① Series Name
- ② Rated Current
- ③ Line to ground capacitor code: Refer to table 1.1.

table 1.1 Line to ground capacitor code

Code	Leakage Current (Input 250/500V 60Hz)	Line to ground capacitor (nominal value)
103	0.5mA/1.0mA max	10,000pF
223	1.0mA/2.0mA max	22,000pF
683	2.5mA/5.0mA max	68,000pF

* When the line to ground capacitor code is different, the attenuation characteristic is different.

- ④ Option
- D: DIN rail installation type

* The dimensions change when the option is set. Refer to External view.

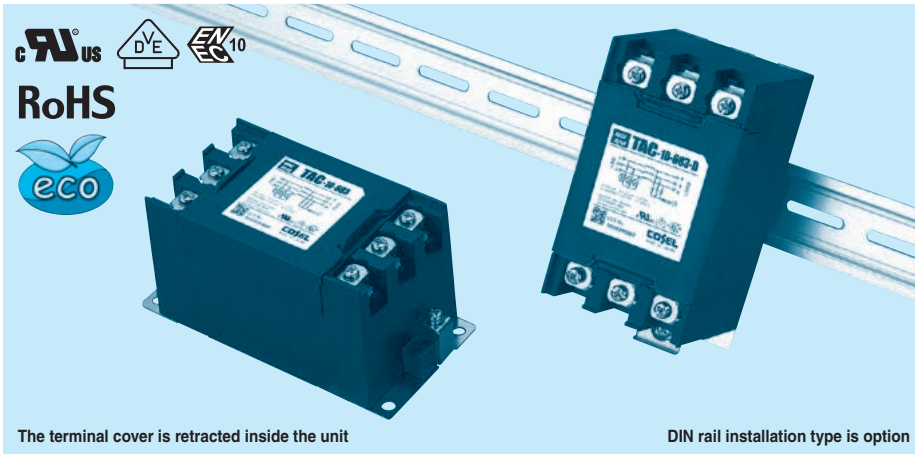

The terminal cover is retracted inside the unit

DIN rail installation type is option

Features of TAC/TAH series

- Three phase rated voltage 500VAC (voltage range:528V max) (1-Stage filter)
- Selectable leakage current value
- Quick and easy push-down terminal

Just connect the wires, push-down and tighten the screws with a screwdriver.

■ TAC: High-attenuation type from 150kHz to 1MHz

■ TAH: Ultra high-attenuation type from 9kHz to 1MHz

Specifications

No.	Items	TAC-04-683	TAC-06-683	TAC-10-683	TAC-20-683	TAC-30-683
		TAH-04-683	TAH-06-683	TAH-10-683	TAH-20-683	TAH-30-683
1	Rated Voltage[V]	AC Three Phase 500 (voltage range:528 max) 50/60Hz				
2	Rated Current[A]	4	6	10	20	30
3	Test Voltage (Terminal-Mounting Plate)	2,000 VAC (Cutoff Current = 100mA), 1minute at room temperature and humidity				
4	Isolation Resistance (Terminal-Mounting Plate)	500 VDC 100MΩ min at room temperature and humidity				
5	Leakage current	Refer to table 1.1				
6	Voltage drop	1.5V max			1.0V max	
7	Safety agency approval temperatures	-25 to +85°C (Refer to Derating Curve)				
8	Operating temperature	-40 to +85°C (Refer to Derating Curve)				
9	Operating humidity	20 to 95%RH (Non condensing)				
10	Storage temperature/humidity	-40 to +85°C/20 to 95%RH (Non condensing)				
11	Vibration	10 to 55Hz, 19.6m/s ² (2G), 3min. Period, 1hour each X, Y and Z axis				
12	Impact	196.1m/s ² (20G), 11ms Once each X, Y and Z axis				
13	Safety agency approvals	UL1283, CSA C22.2 No.8 (C-UL) , DIN EN60939 VDE0565 Teil3-1, ENEC				
14	Case size (without projection) /Weight	63×64×128 mm [2.48×2.52×5.04 inches] (W×H×D) / 620g max (Option : -D refer to external view)				

Circuit Diagram

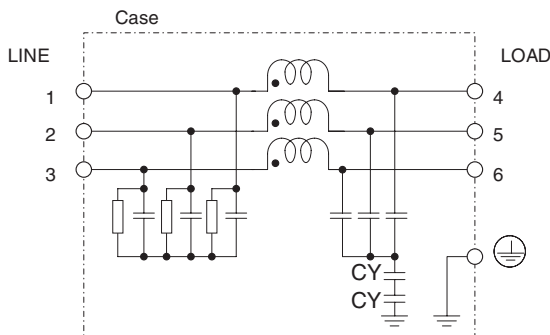

CY : Line to ground capacitor ⊥ : Mounting Plate

Derating Curve

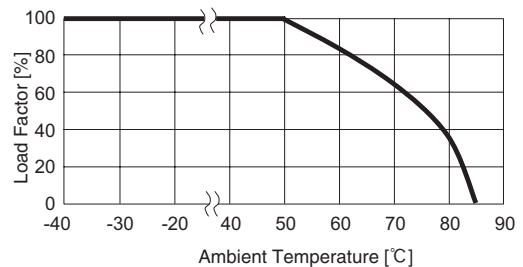

External view

This product is shipped in the following condition, because it is equipped with push-down terminals.

- ① The terminal cover is retracted inside the unit.
- ② The screws for connecting the terminals are held in the up right position.

Standard Type

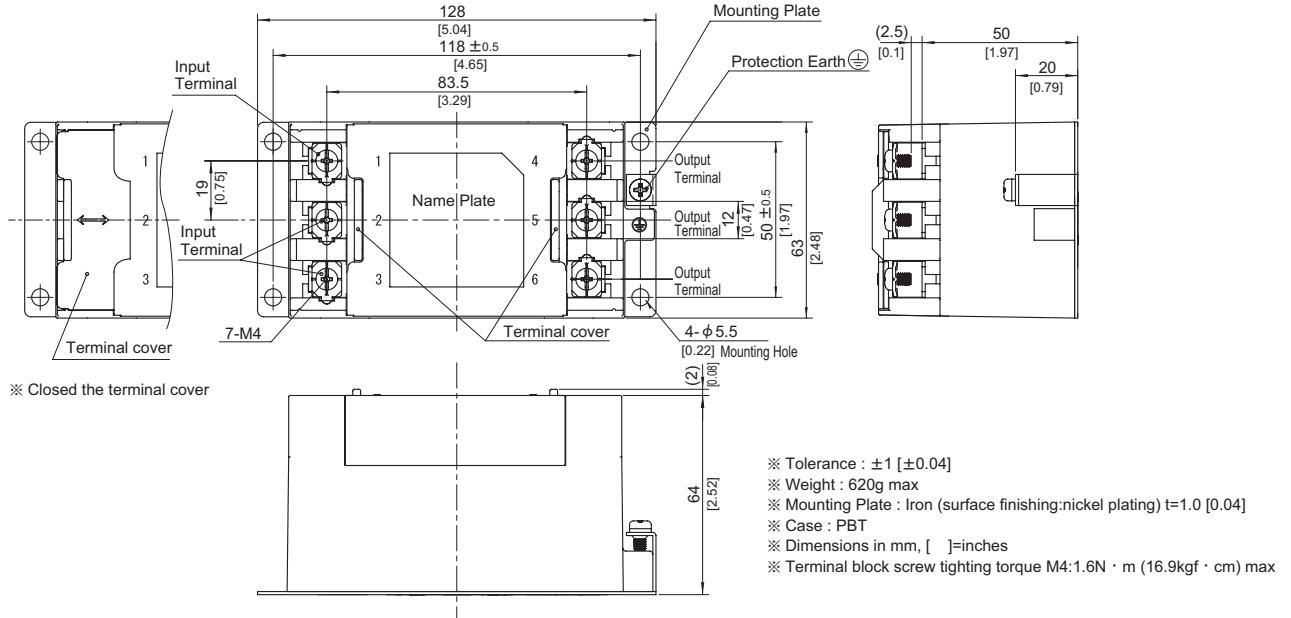

DIN rail installation Type

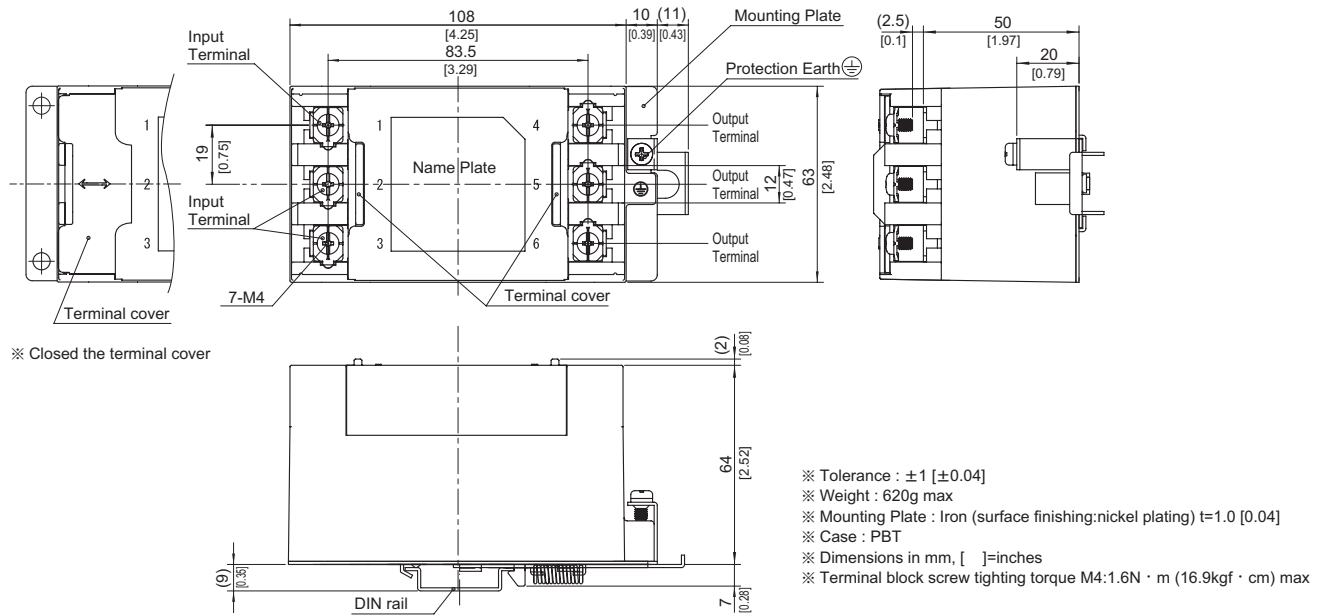

■Note when installing the EMI/EMC Filter on a DIN rail.

When the EMI/EMC Filter is grounded through the DIN rail, the proper noise attenuation may not be achieved.

Be sure to connect the protection earth (PE) of the EMI/EMC Filter body to the earth.

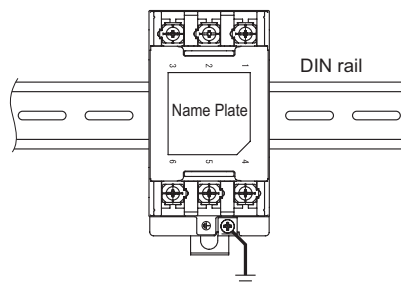

TAC-04-103

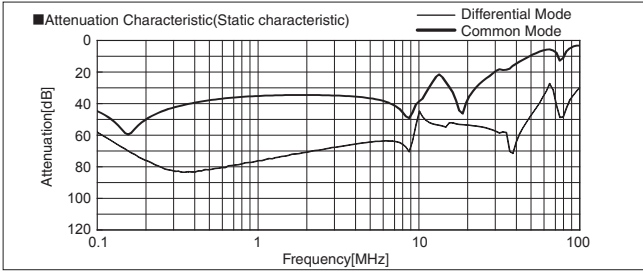

TAC-04-223

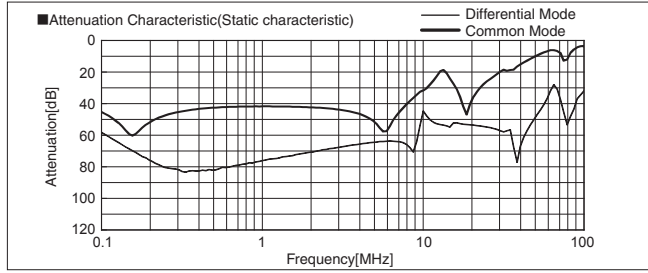

TAC-04-683

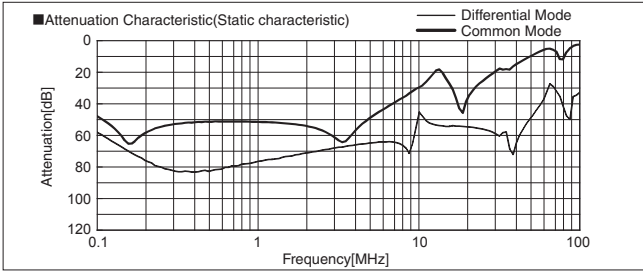

TAC-06-103

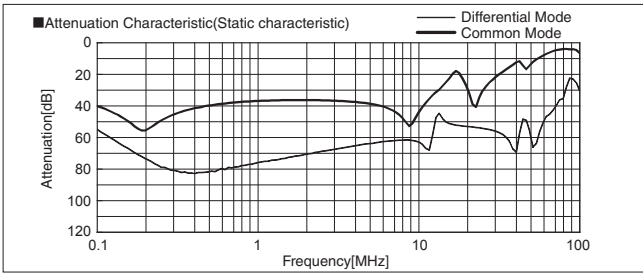

TAC-06-223

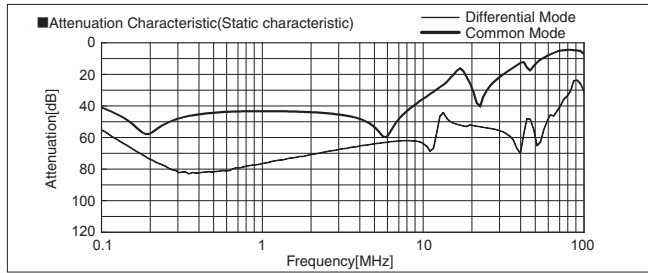

TAC-06-683

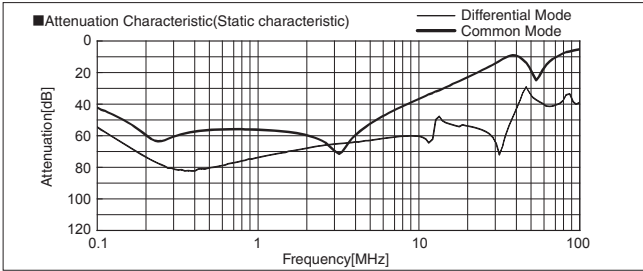

TAC-10-103

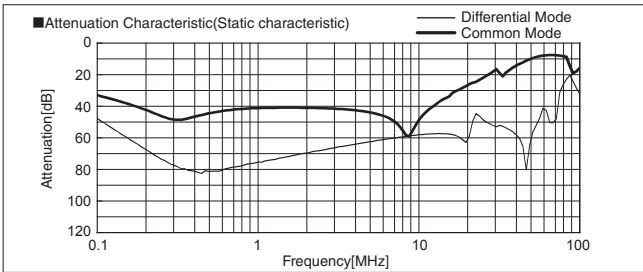

TAC-10-223

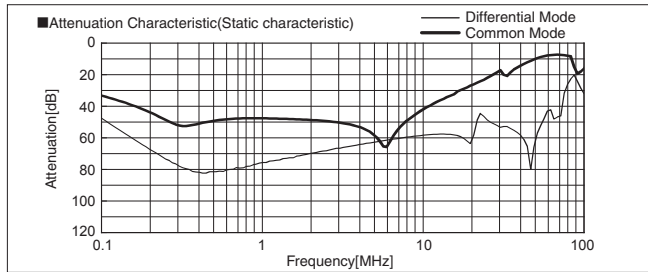

TAC-10-683

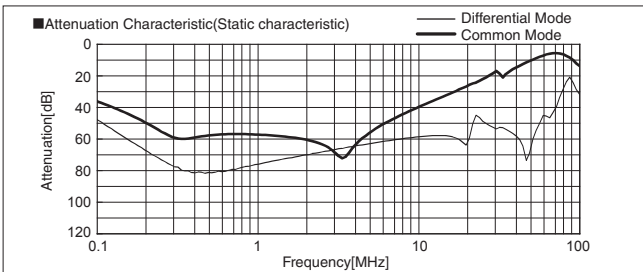

TAC-20-103

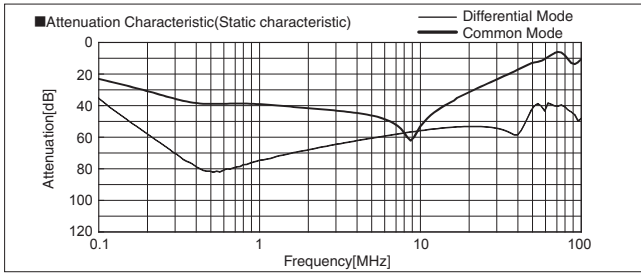

TAC-20-223

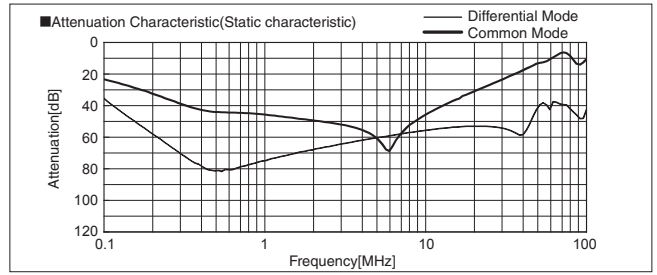

TAC-20-683

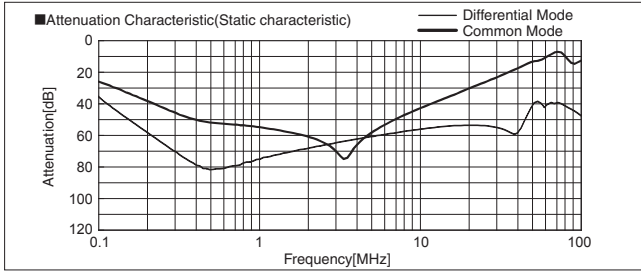

TAC-30-103

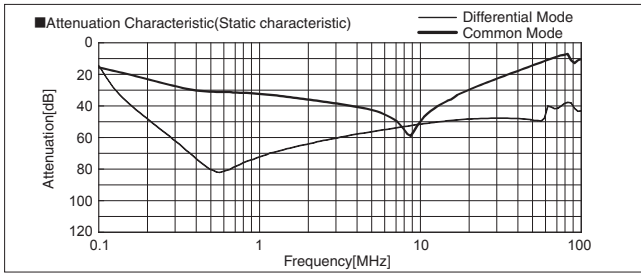

TAC-30-223

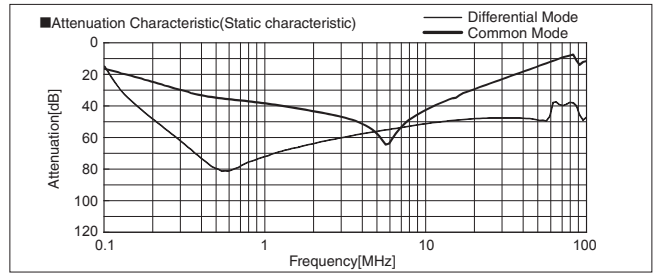

TAC-30-683

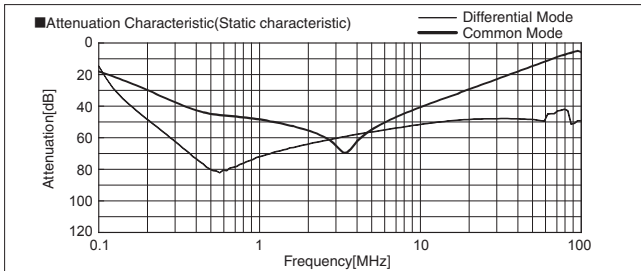

TAH-04-103

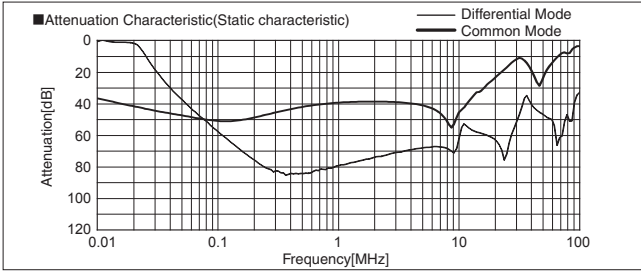

TAH-04-223

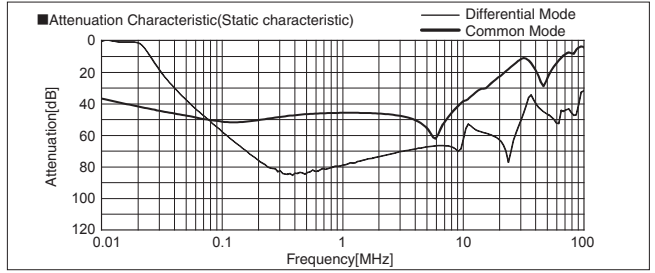

TAH-04-683

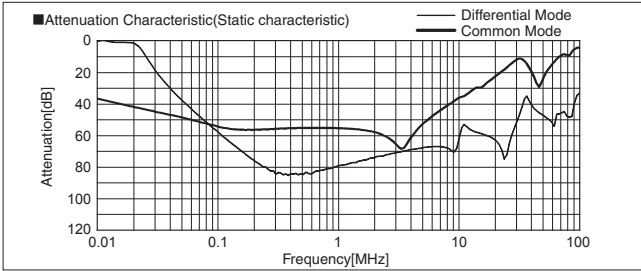

TAH-06-103

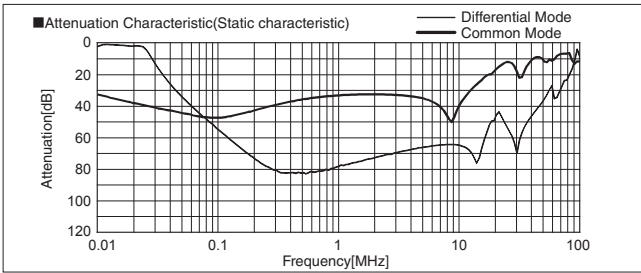

TAH-06-223

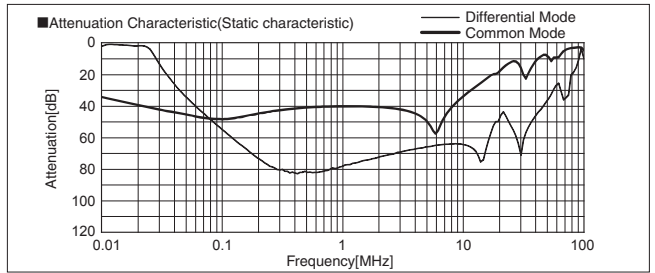

TAH-06-683

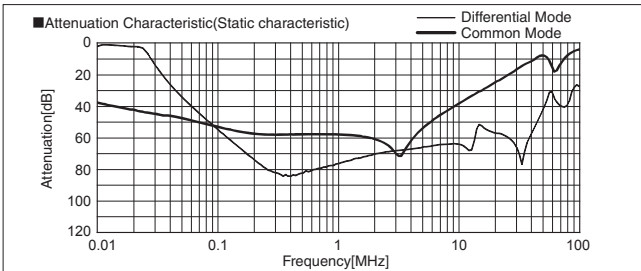

TAH-10-103

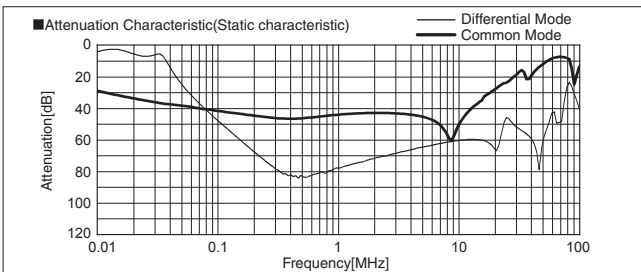

TAH-10-223

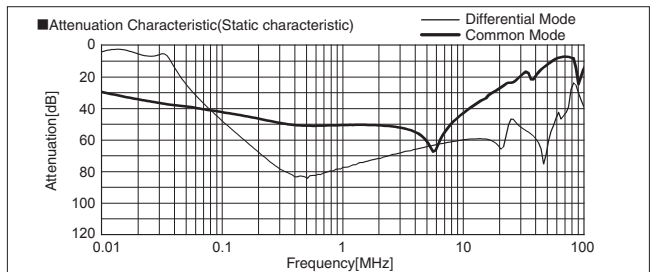

TAH-10-683

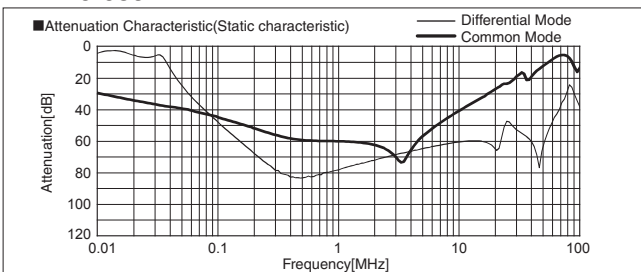

TAH-20-103

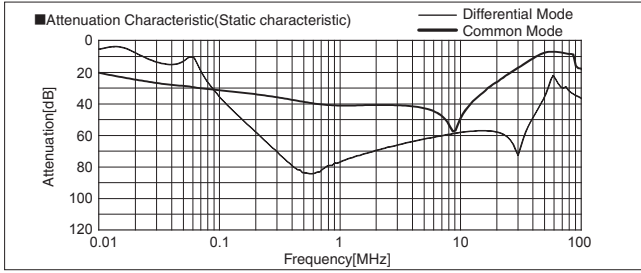

TAH-20-223

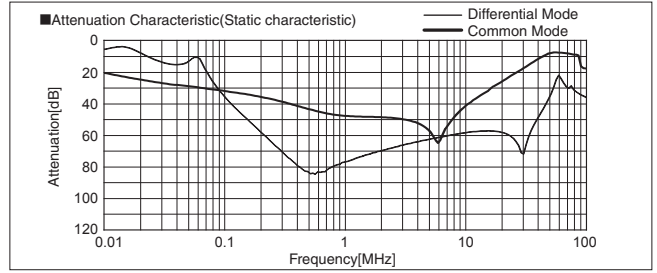

TAH-20-683

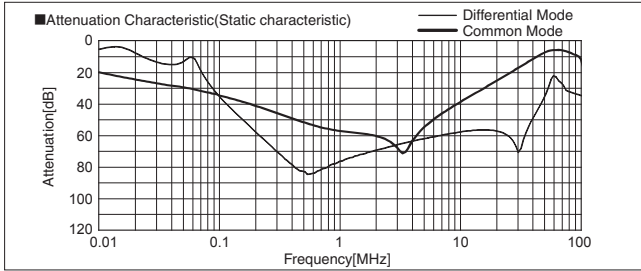

TAH-30-103

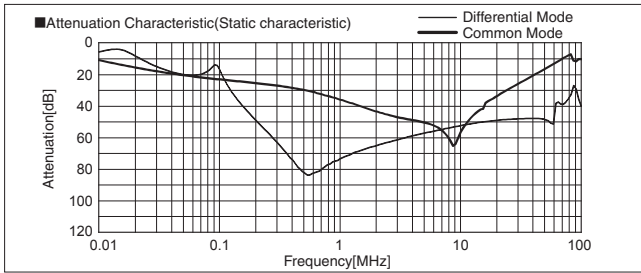

TAH-30-223

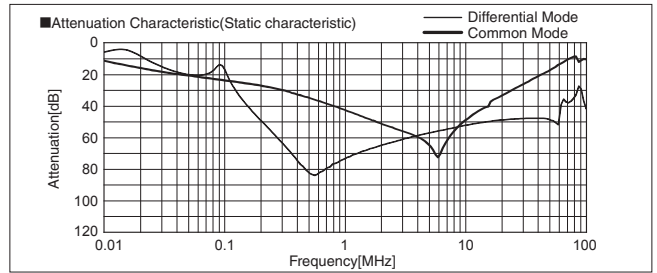

TAH-30-683

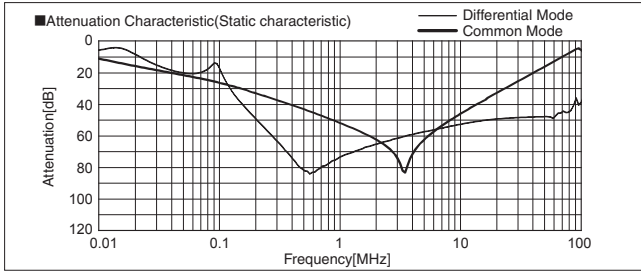

External view

TAC-50-□□□ / TAC-60-□□□
TAH-50-□□□ / TAH-60-□□□

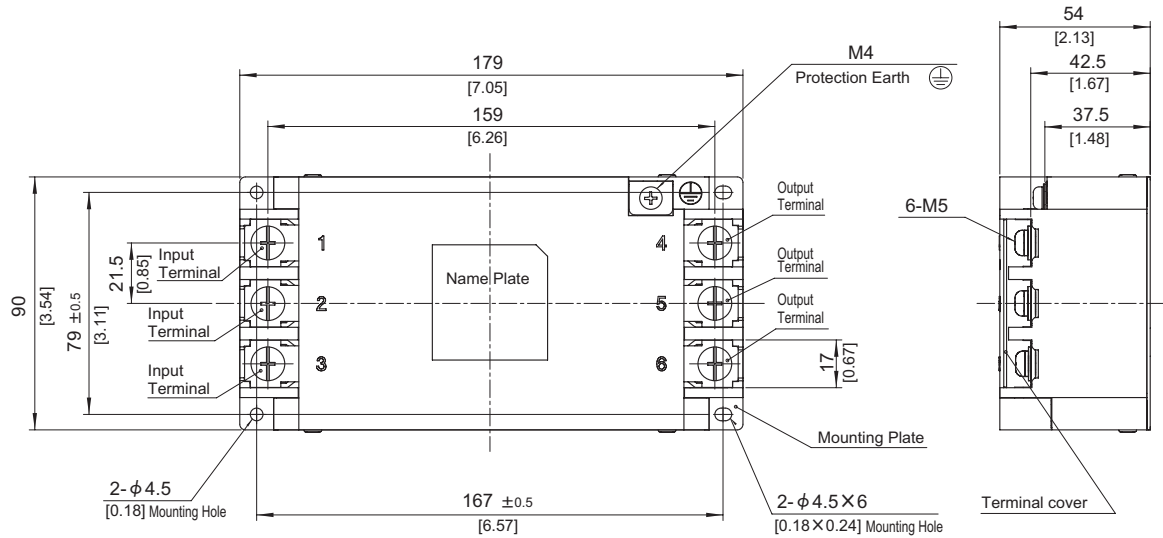

※ Can not be mounted upside-down.
(mounted the top surface)

- ※ Tolerance : ± 1 [±0.04]
- ※ Weight : 1.4kg max
- ※ Mounting Plate : Iron (surface finishing:nickel plating) t=1.2 [0.05]
- ※ Case : PBT
- ※ Dimensions in mm, []=inches
- ※ Terminal block screw tightening torque M5:3.0N · m (30.7kgf · cm) max
- ※ Protection Earth screw tightening torque M4:1.6N · m (16.9kgf · cm) max

TAC-80-□□□ / TAC-100-□□□
TAH-80-□□□ / TAH-100-□□□

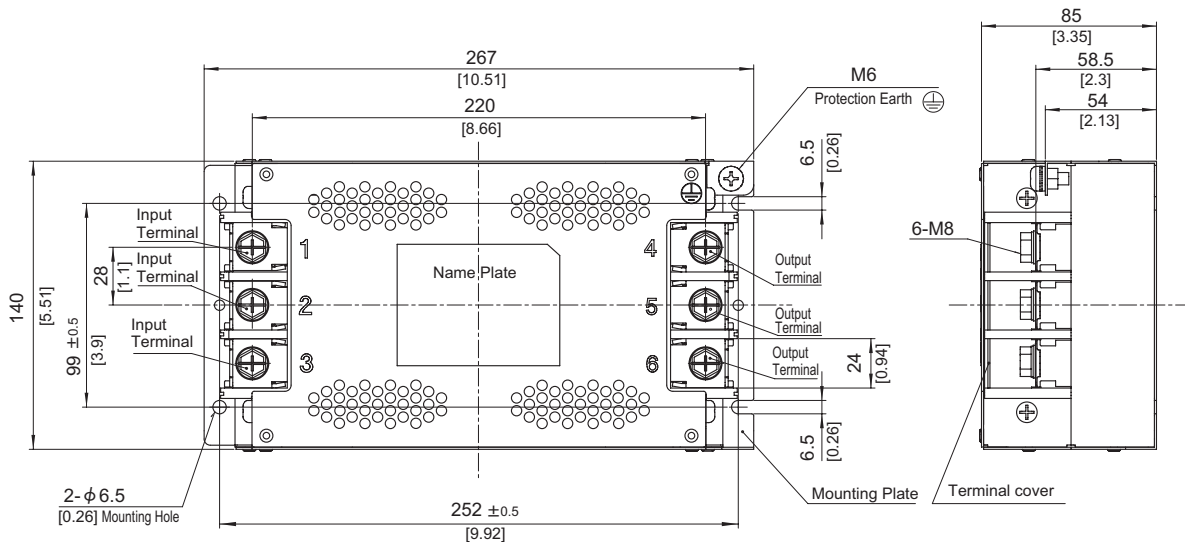

※ Can not be mounted upside-down.
(mounted the top surface)

- ※ Tolerance : ± 1 [±0.04]
- ※ Weight : 3.8kg max
- ※ Chassis Material : Stainless steel t=1.0 [0.04]
- ※ Dimensions in mm, []=inches
- ※ Terminal block screw tightening torque M8:9.2N · m (93.9kgf · cm) max
- ※ Protection Earth screw tightening torque M6:5.8N · m (59.2kgf · cm) max

External view

TAC-150-□□□
TAH-150-□□□

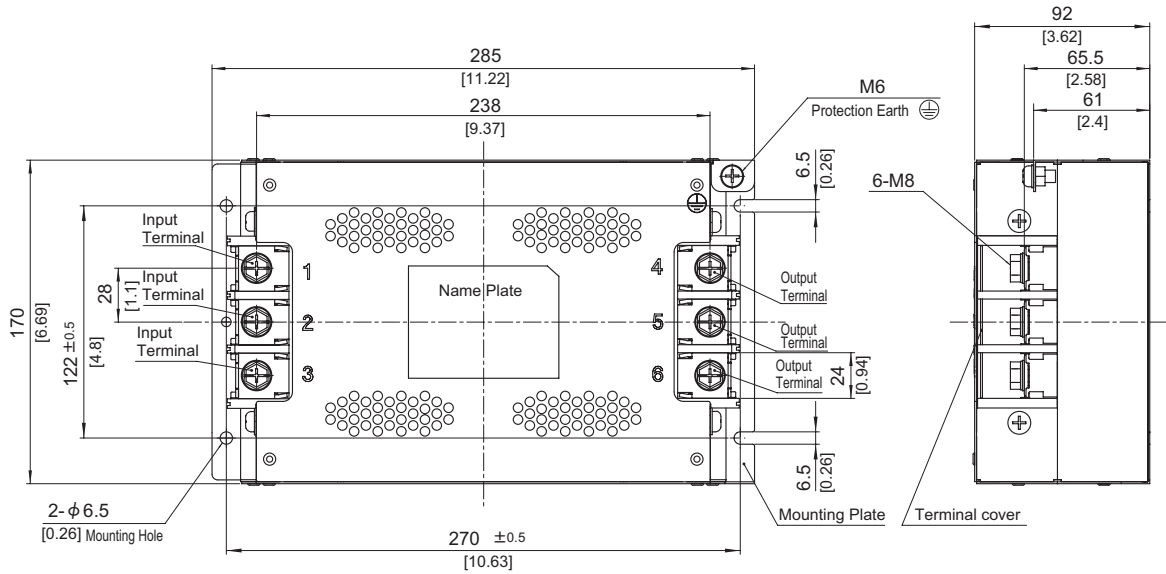

※ Can not be mounted upside-down.
(mounted the top surface)

- ※ Tolerance : ± 1 [± 0.04]
- ※ Weight : 4.8kg max
- ※ Chassis Material : Stainless steel $t=1.0$ [0.04]
- ※ Dimensions in mm, []=inches
- ※ Terminal block screw tightening torque M8:9.2N · m (93.9kgf · cm) max
- ※ Protection Earth screw tightening torque M6:5.8N · m (59.2kgf · cm) max

TAC-50-103

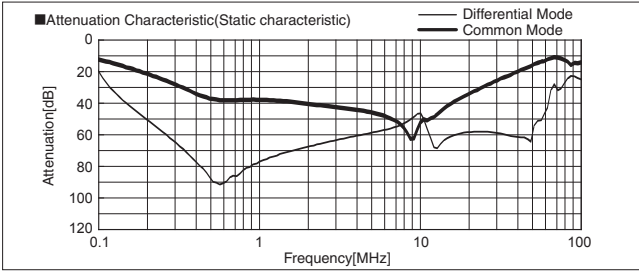

TAC-50-223

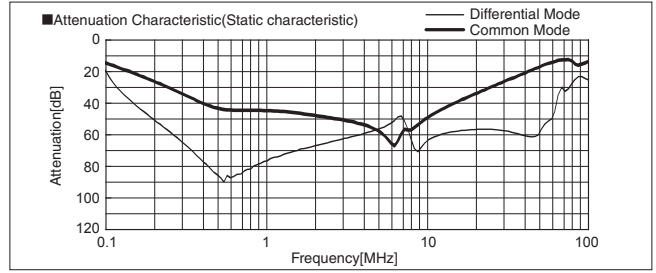

TAC-50-333

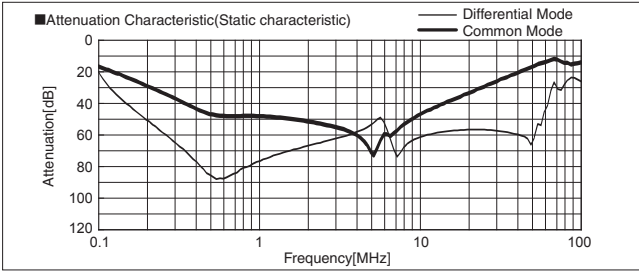

TAC-60-103

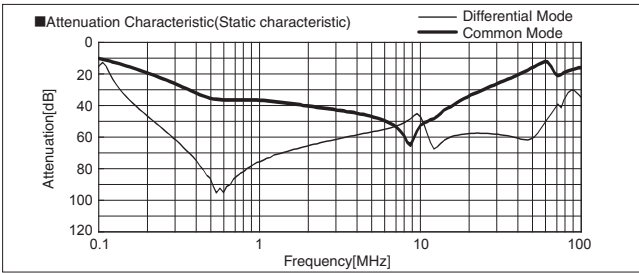

TAC-60-223

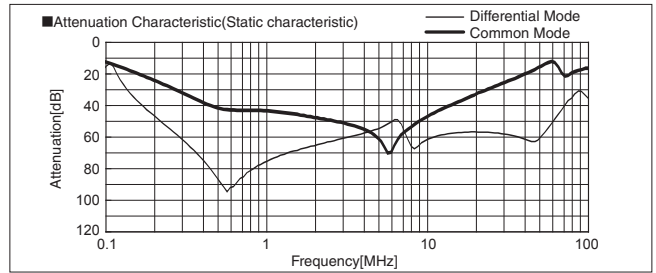

TAC-60-333

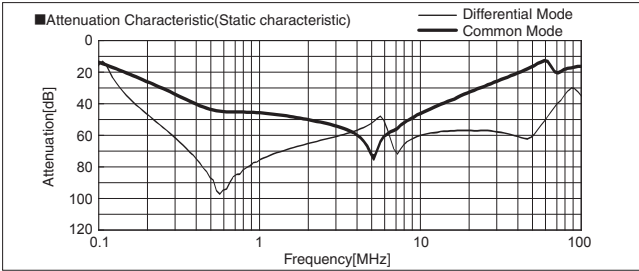

TAC-80-103

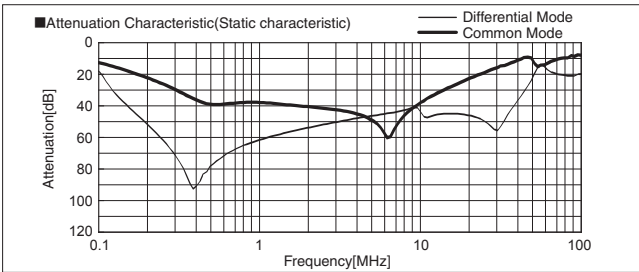

TAC-80-223

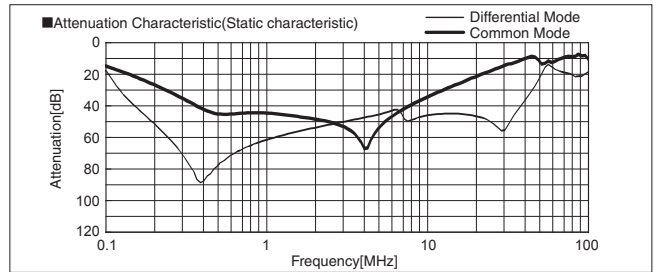

TAC-80-333

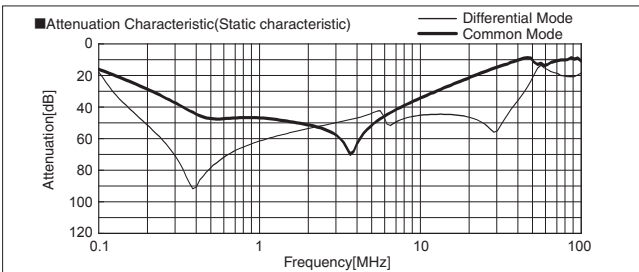

TAH-50-103

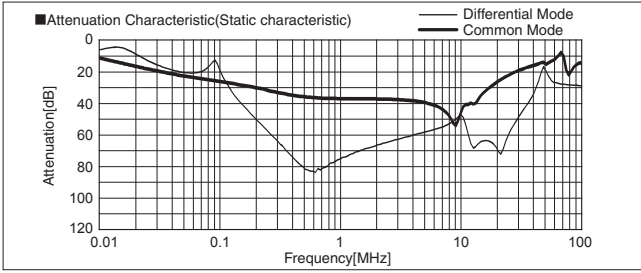

TAH-50-223

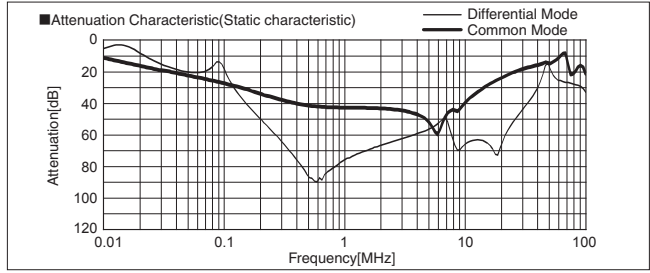

TAH-50-333

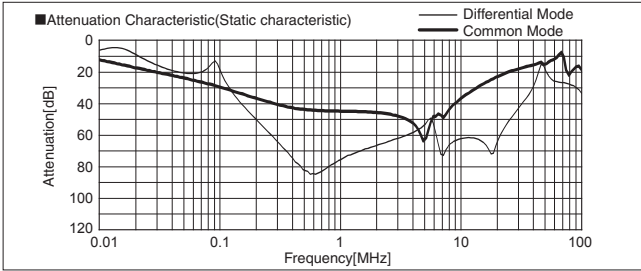

TAH-60-103

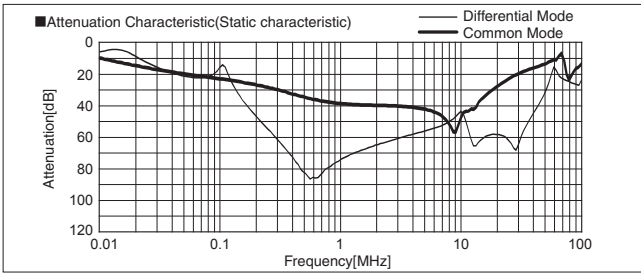

TAH-60-223

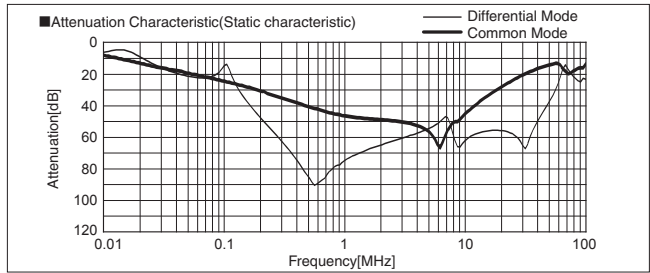

TAH-60-333

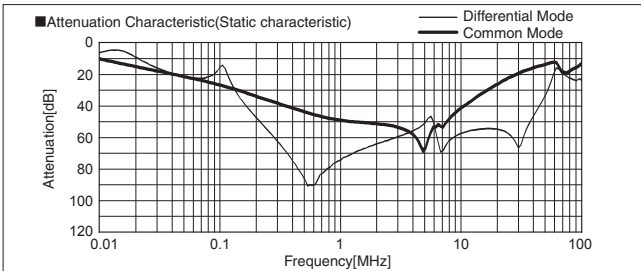

TAH-80-103

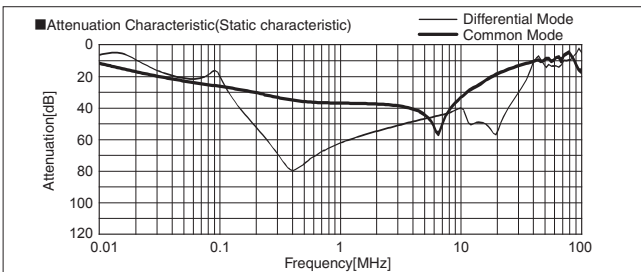

TAH-80-223

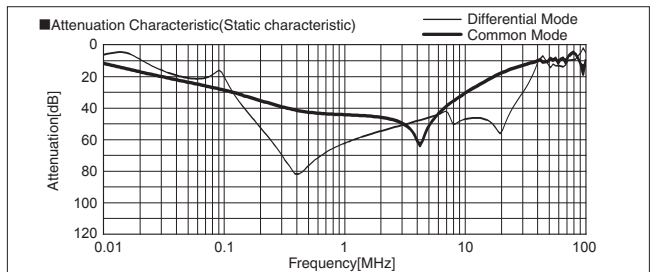

TAH-80-333

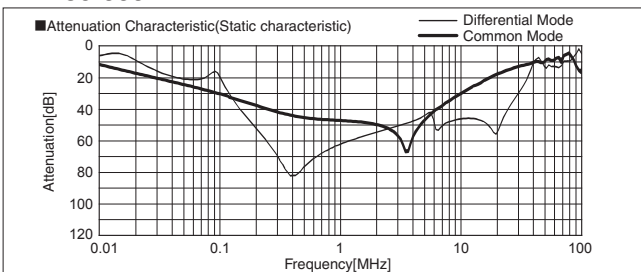

TAC-100-103

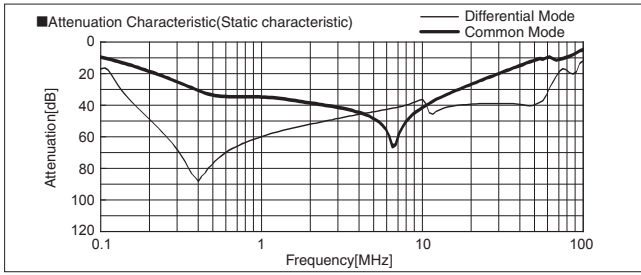

TAC-100-223

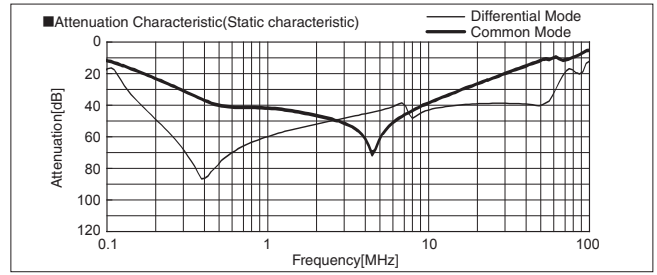

TAC-100-333

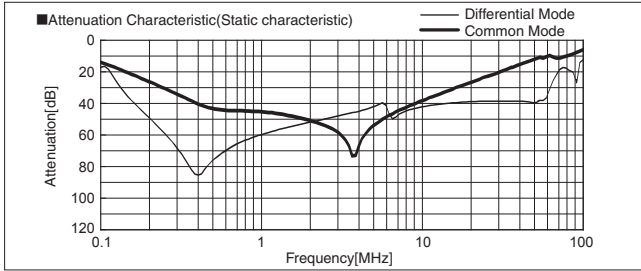

TAC-150-103

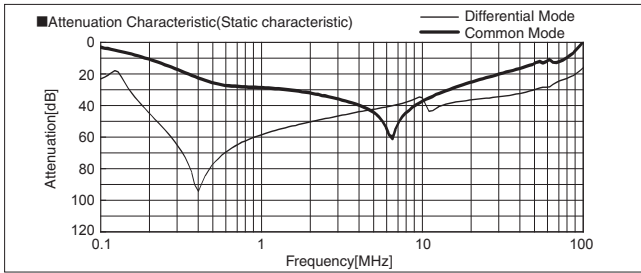

TAC-150-223

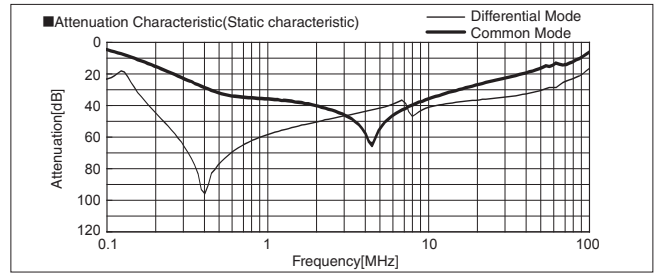

TAC-150-333

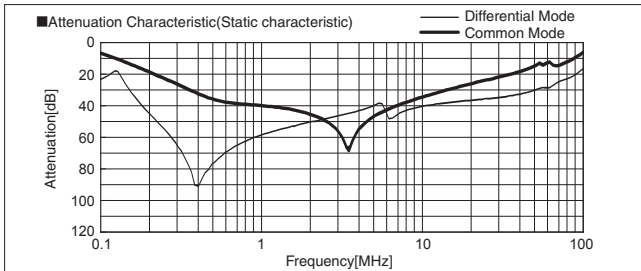

TAH-100-103

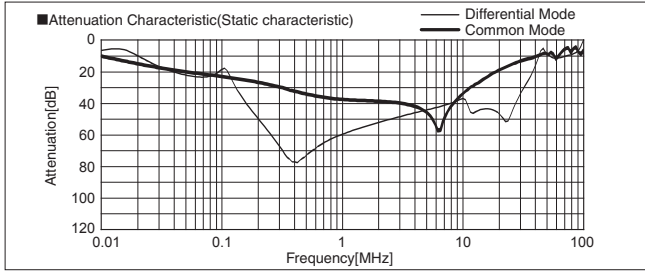

TAH-100-223

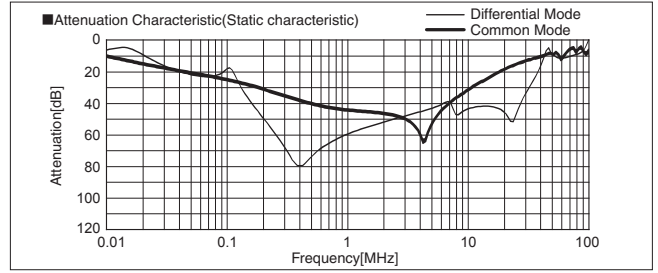

TAH-100-333

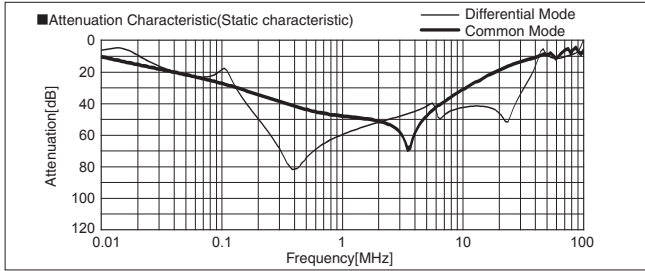

TAH-150-103

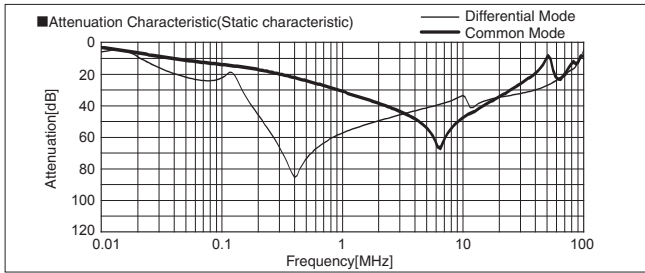

TAH-150-223

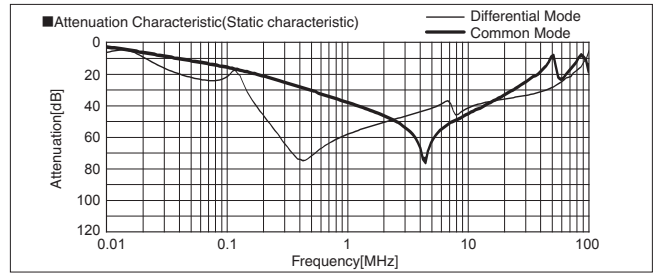

TAH-150-333

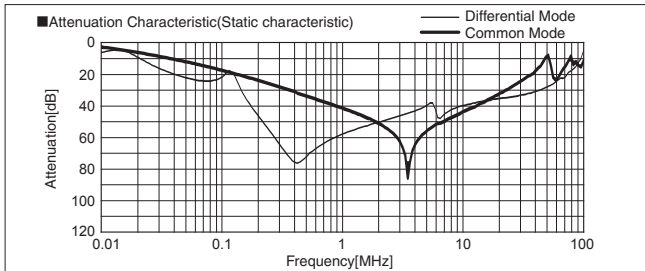

TAC-50-103-U

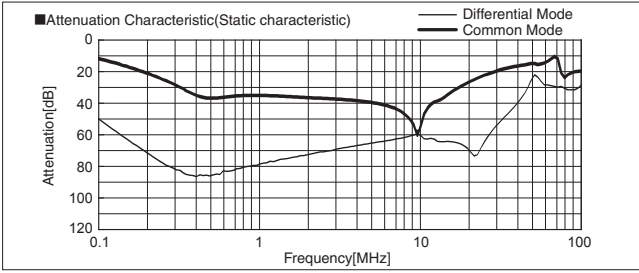

TAC-50-223-U

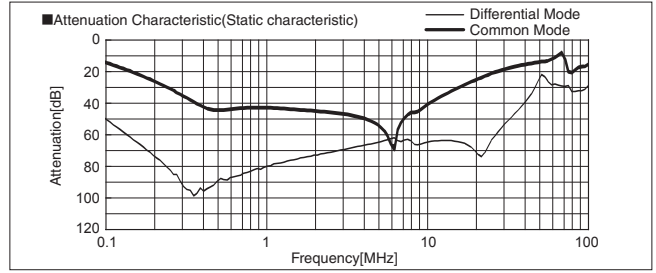

TAC-50-333-U

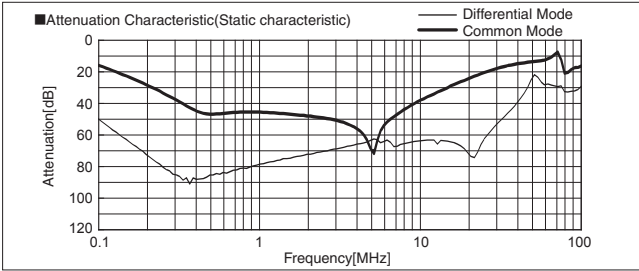

TAC-60-103-U

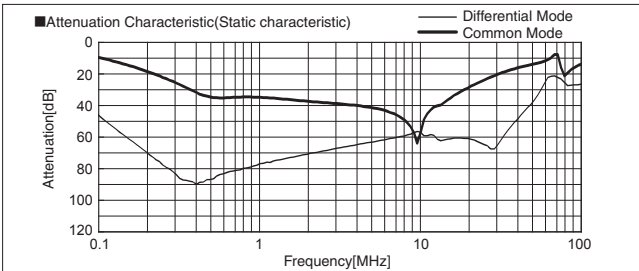

TAC-60-223-U

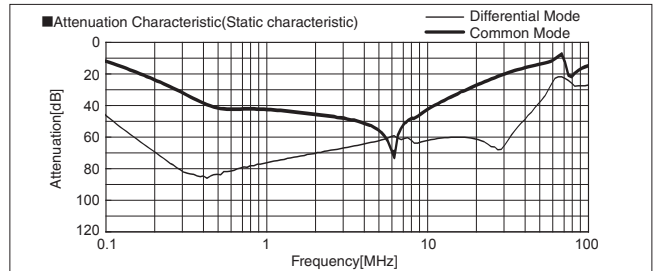

TAC-60-333-U

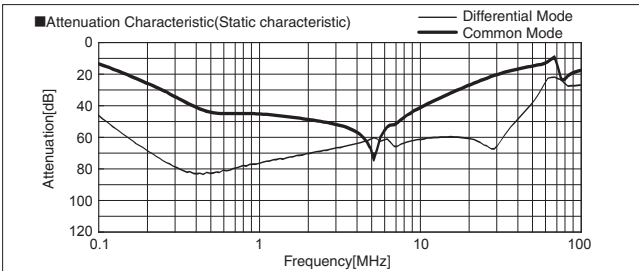

TAC-80-103-U

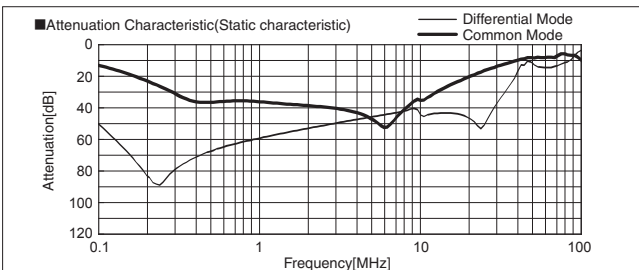

TAC-80-223-U

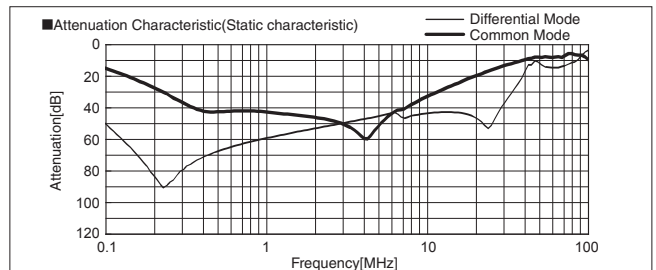

TAC-80-333-U

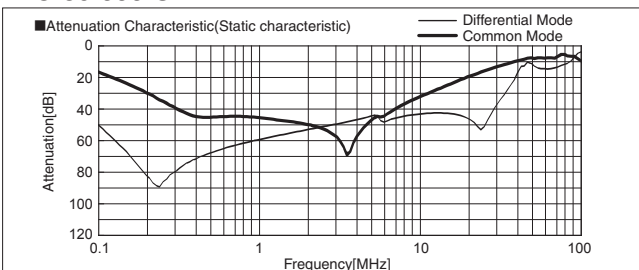

TAH-50-103-U

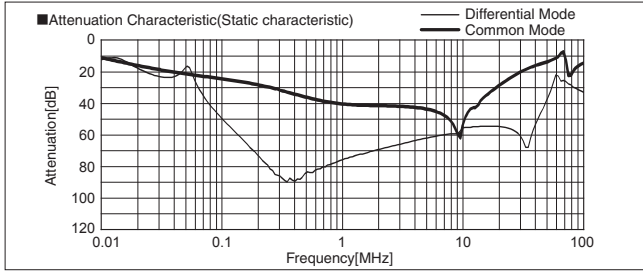

TAH-50-223-U

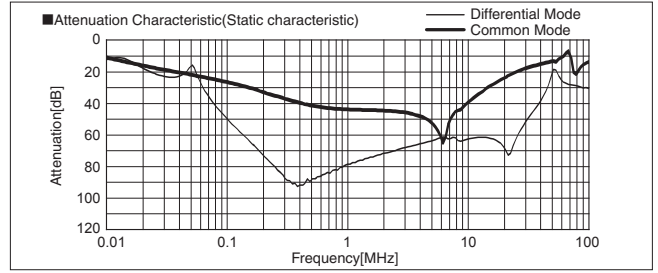

TAH-50-333-U

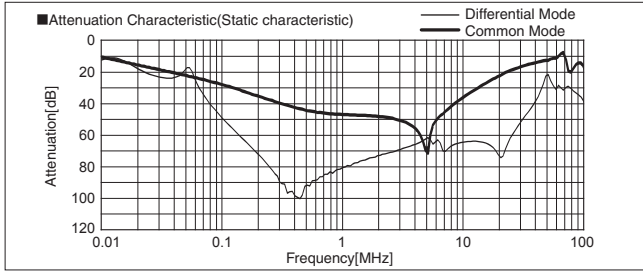

TAH-60-103-U

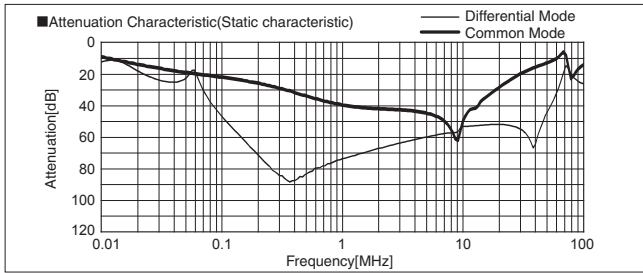

TAH-60-223-U

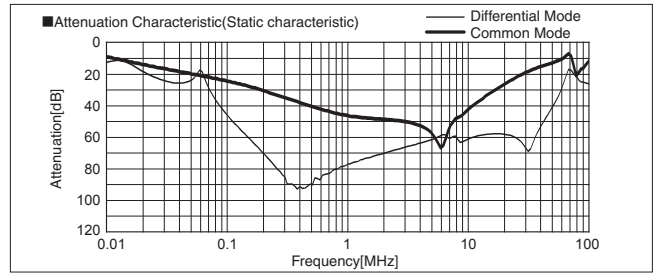

TAH-60-333-U

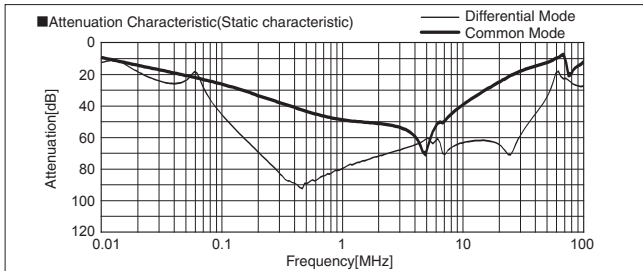

TAH-80-103-U

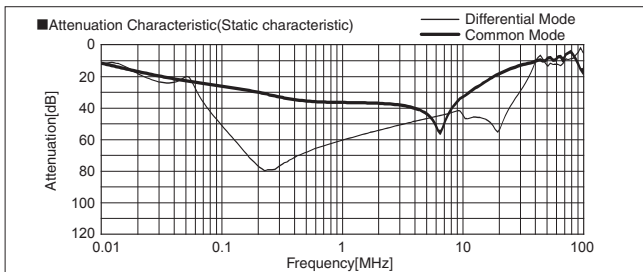

TAH-80-223-U

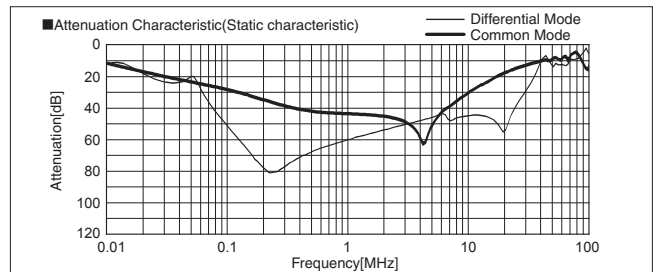

TAH-80-333-U

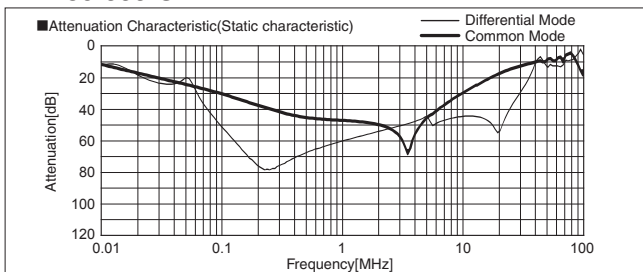

TAC-100-103-U

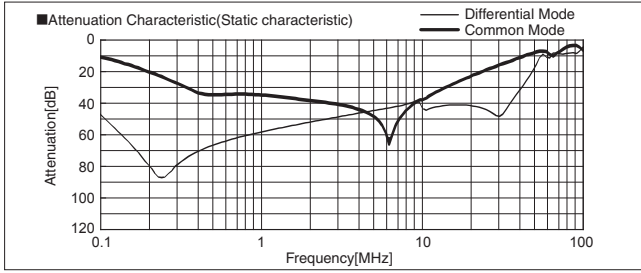

TAC-100-223-U

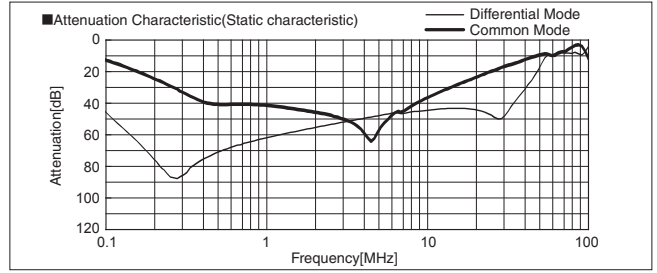

TAC-100-333-U

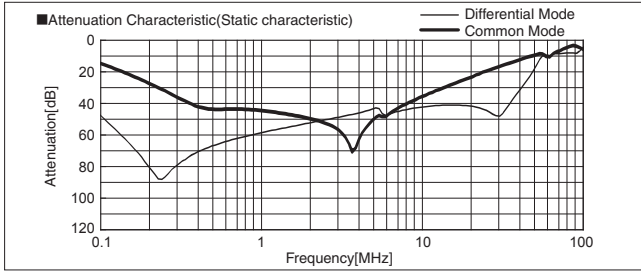

TAC-150-103-U

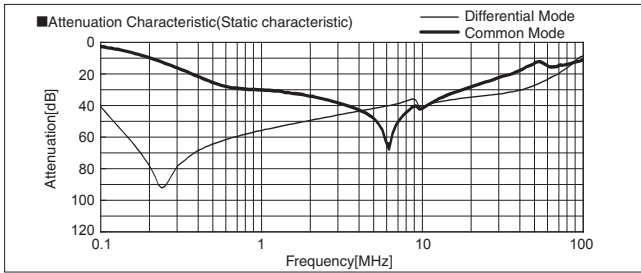

TAC-150-223-U

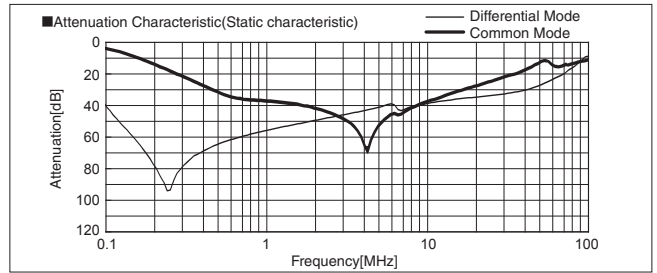

TAC-150-333-U

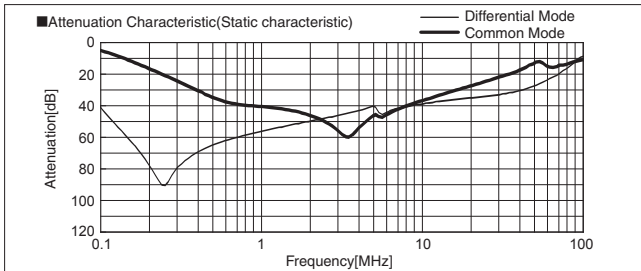

TAH-100-103-U

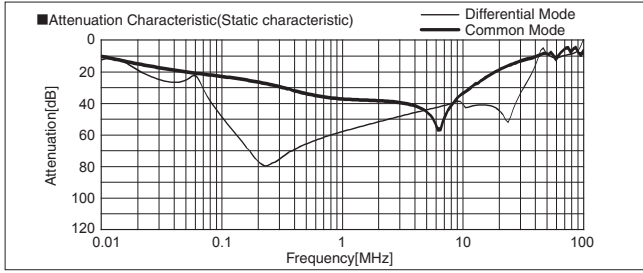

TAH-100-223-U

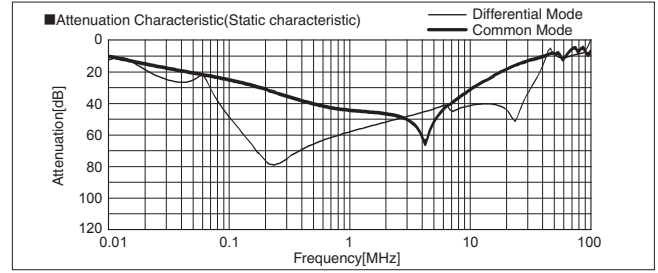

TAH-100-333-U

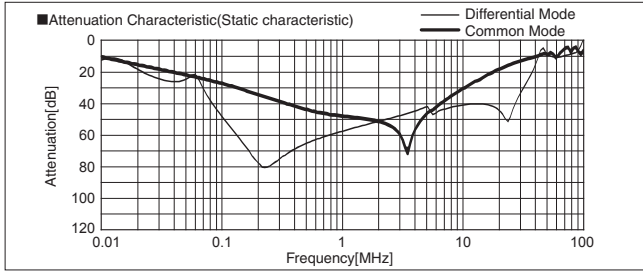

TAH-150-103-U

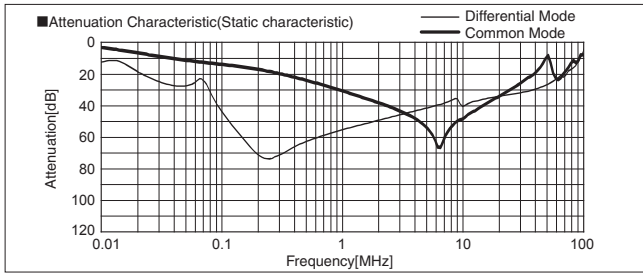

TAH-150-223-U

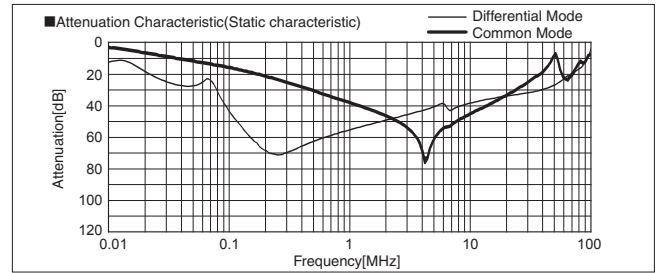

TAH-150-333-U

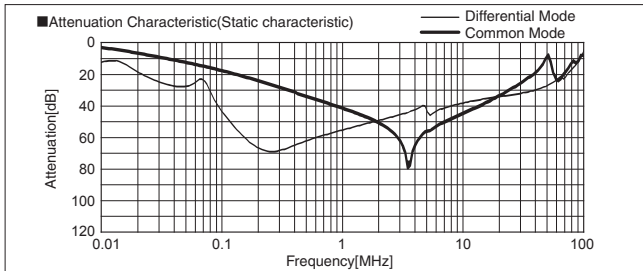

External view

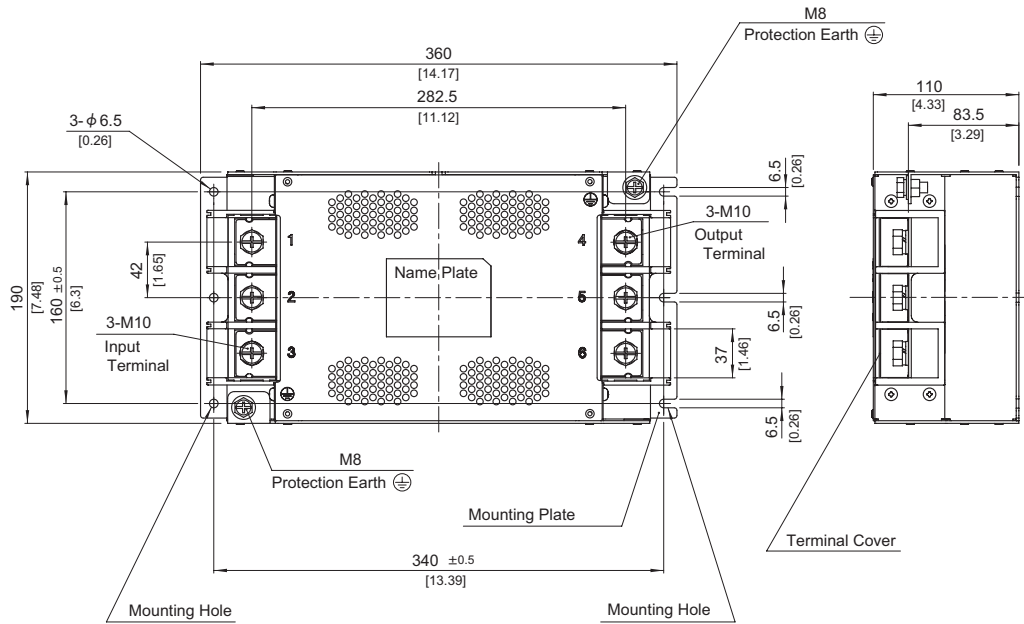

※ Can not be mounted upside-down.
(mounted the top surface)

- ※ Tolerance : ± 1 [± 0.04]
- ※ Weight : 8.0kg max
- ※ Mounting Plate : Stainless steel $t=2.0$ [0.08]
- ※ Dimensions in mm, []=inches
- ※ Terminal block screw tightening torque M10 : 14.2N · m (144.9kgf · cm) max
- ※ Protection Earth screw tightening torque M8 : 9.2N · m (93.9kgf · cm) max

TAC-200-103

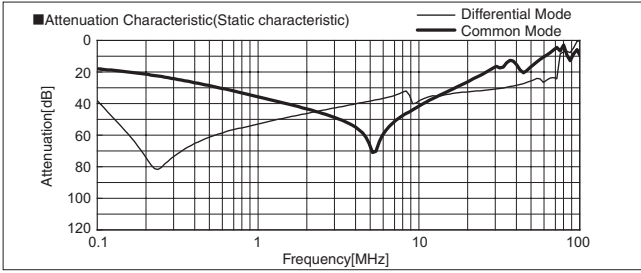

TAC-200-223

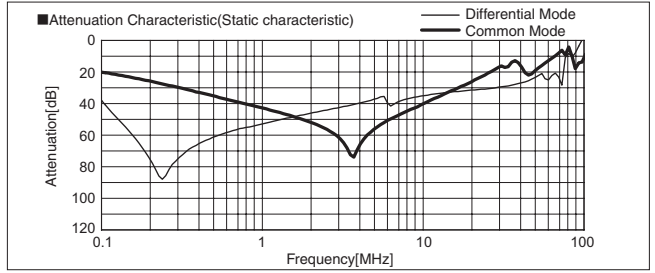

TAC-200-333

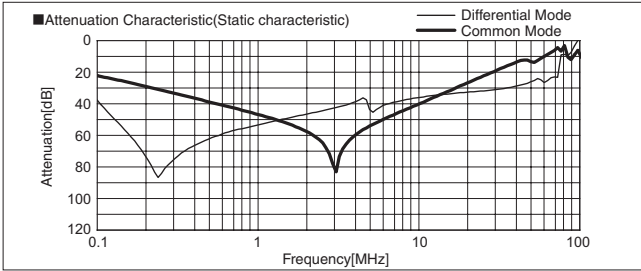

TAC-250-103

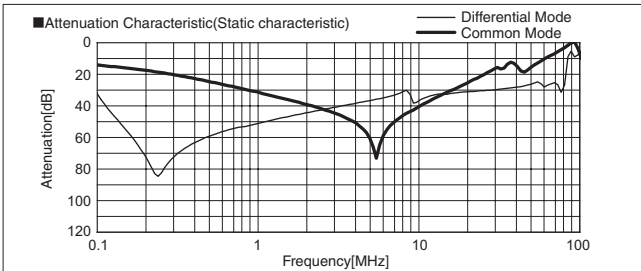

TAC-250-223

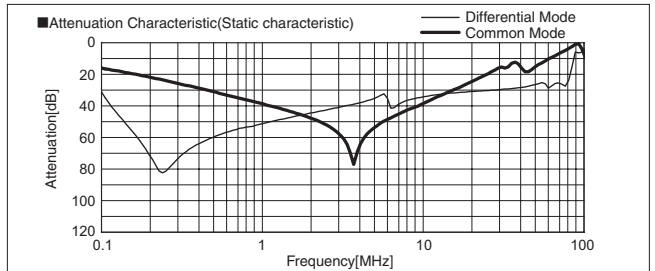

TAC-250-333

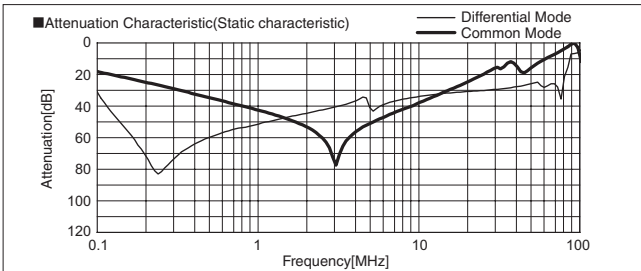

TAC-300-103

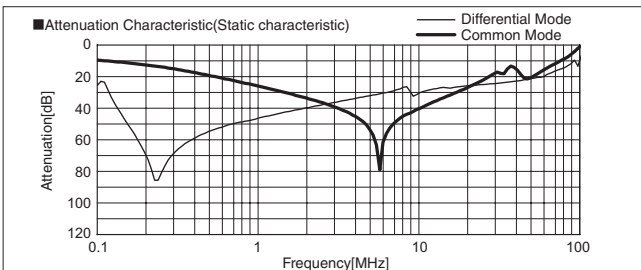

TAC-300-223

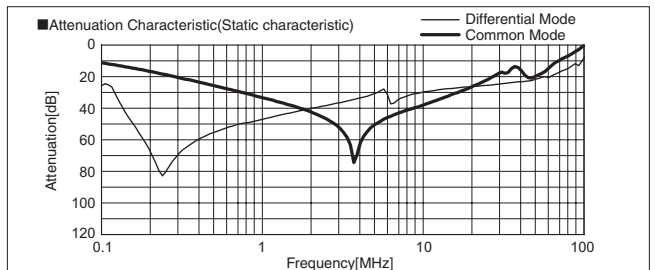

TAC-300-333

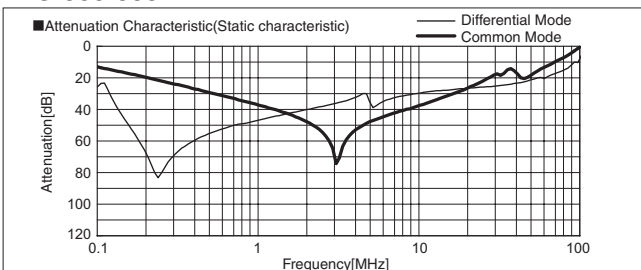

TAC-200-103-U

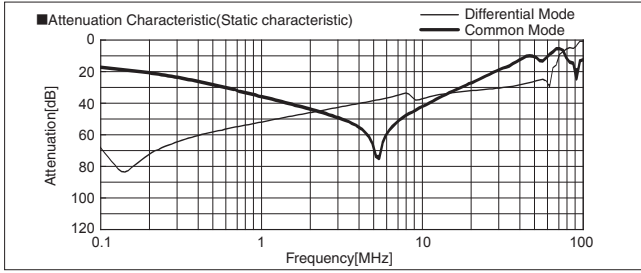

TAC-200-223-U

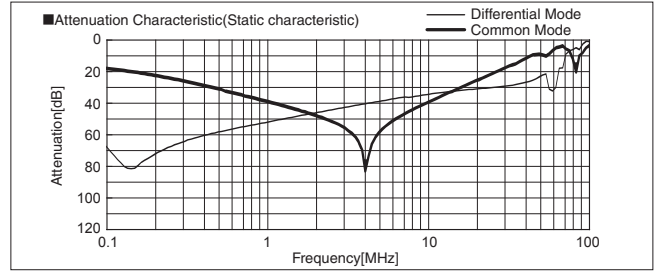

TAC-200-333-U

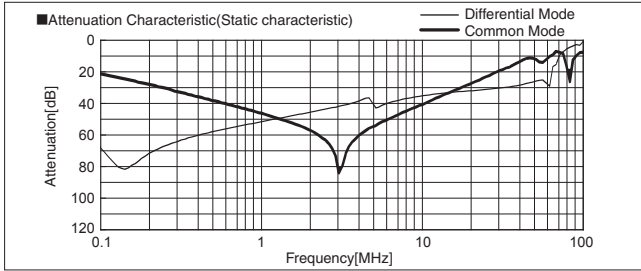

TAC-250-103-U

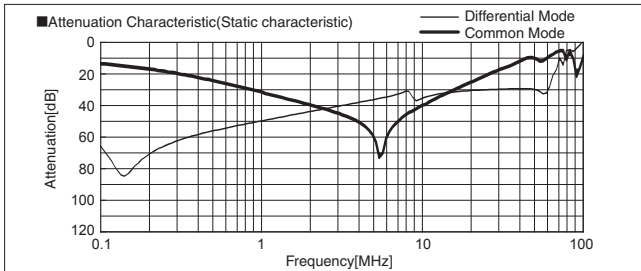

TAC-250-223-U

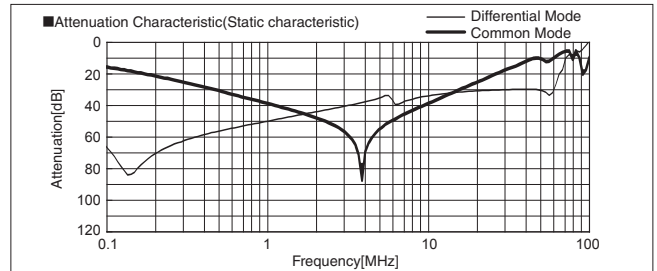

TAC-250-333-U

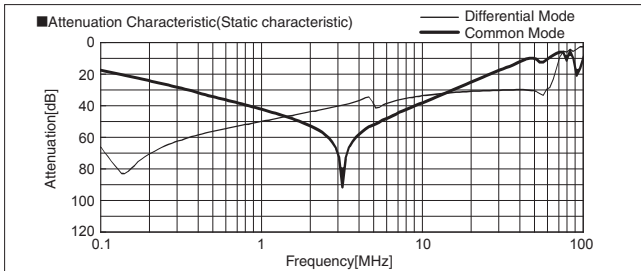

TAC-300-103-U

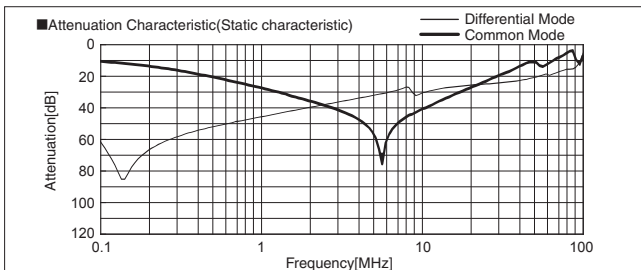

TAC-300-223-U

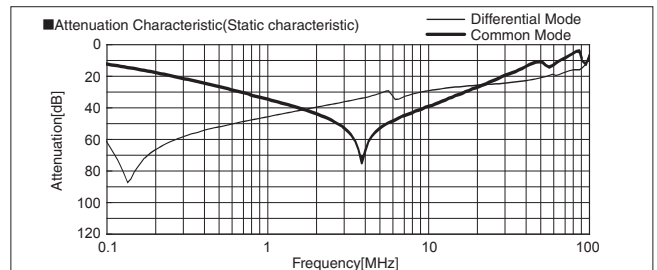

TAC-300-333-U

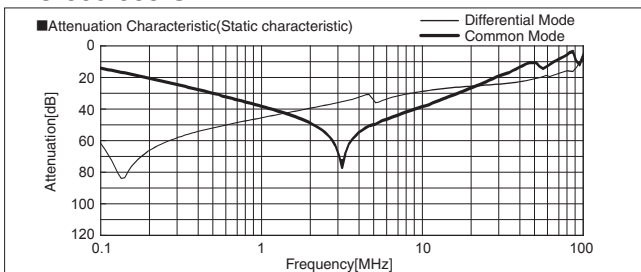

FTA series(40,50,60A)

FTA -50 -683 -□

① ② ③ ④

- ① Model Name
- ② Rated Current
- ③ Line to ground capacitor code: See table 1.1.

table 1.1 Line to ground capacitor code

Code	Leakage Current (Input 250/500V 60Hz) (335 only 250/400V 60Hz)	Line to ground capacitor (nominal value)
223	1.0mA/2.0mA max	22,000pF
683	2.5mA/5.0mA max	68,000pF
104	3.5mA/7.0mA max	100,000pF
335	160mA/250mA max	3.3μF

* When the line to ground capacitor code is different, the attenuation characteristic is different.

- ④ Option
- H: Ultra high attenuation type "335" is not applied.
- U: Improve differential mode attenuation (Rated voltage 250V)
- G: With switch of line to ground capacitor Only "335" is applied.
- * Leakage current 160mA/250mA max when the switch state is ON (switched to "I"). 10μA/16μA max when the switch state is OFF (switched to "O").



Features of FTA series

Book type (Space-saving type)

- 1-stage filter General-purpose High-attenuation (150kHz - 1MHz)
- Selectable leakage current value, Ultra high attenuation type "335" for EU(Wye type with neutral earth system), With switch of line to ground capacitor "-G"

Specifications

No.	Items	FTA-40-683	FTA-50-683	FTA-60-683
1	Rated Voltage[V]	AC Three Phase 500 (voltage range:528 max) 50/60Hz *1 *2		
2	Rated Current[A]	40	50	60
3	Test Voltage (Terminal-Mounting Plate)	2,500 VAC (Cutoff Current = 100mA), 1minute at room temperature and humidity *3		
4	Isolation Resistance (Terminal-Mounting Plate)	500 VDC 100MΩ min at room temperature and humidity *4		
5	Leakage current 250/500V 60Hz	2.5mA/5.0mA max		
6	DC resistance	8.5mΩ max	6mΩ max	4.5mΩ max
7	Safety agency approval temperatures	-25 to +85°C (Refer to Derating Curve)		
8	Operating temperature	-40 to +85°C (Refer to Derating Curve)		
9	Operating humidity	20 to 95%RH (Non condensing)		
10	Storage temperature/humidity	-40 to +85°C/20 to 95%RH (Non condensing)		
11	Vibration	10 to 55Hz, 19.6m/s ² (2G), 3min. Period, 1hour each X, Y and Z axis		
12	Impact	196.1m/s ² (20G), 11ms Once each X, Y and Z axis		
13	Safety agency approvals	UL1283, CSA C22.2 No.8 (C-UL) , DIN EN60939 VDE0565 Teil3-1, ENEC		
14	Case size (without projection)	65 X 84 X 153 mm (W X H X D) (Option: -G refer to external view) [2.56 X 3.31 X 6.02 inches] (W X H X D)		
15	Weight	1.2kg max		

- *1 Only capacitor code "335", Three Phase Δ-connection : 400 (440 max), Wye-connection : 500 (528 max)
- *2 Only "FTA-□□□□□□-U", Three Phase 250 (275 max)
- *3 Only capacitor code "335", 2,800VDC (Cutoff Current = 10mA), 1minute at room temperature and humidity.
- *4 Only capacitor code "335", Isolation resistance specification is deleted.

Circuit Diagram

(1) Line to ground capacitor code : 223, 683, 104

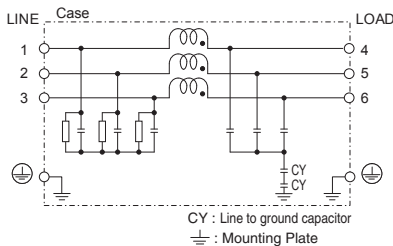

(2) Line to ground capacitor code : 335

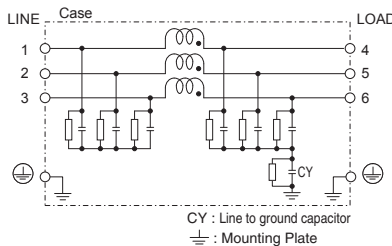

(3) Line to ground capacitor code : 223, 683, 104
Option : U

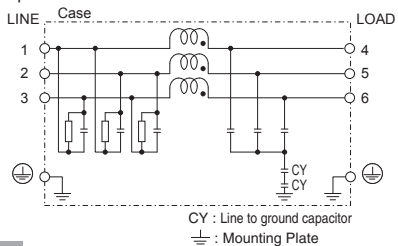

(4) FTA-□□□-335-U

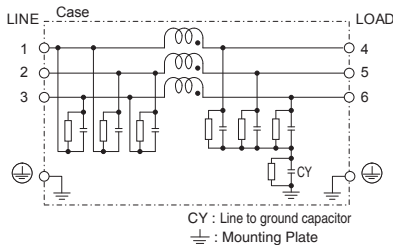

(5) FTA-□□□-335-G

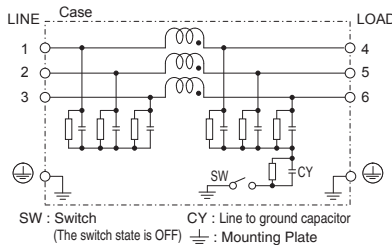

Derating Curve

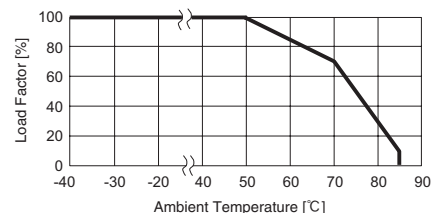

External view

Standard Type

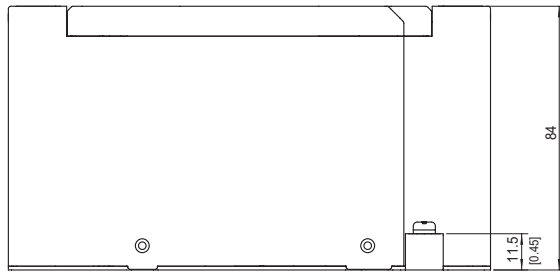
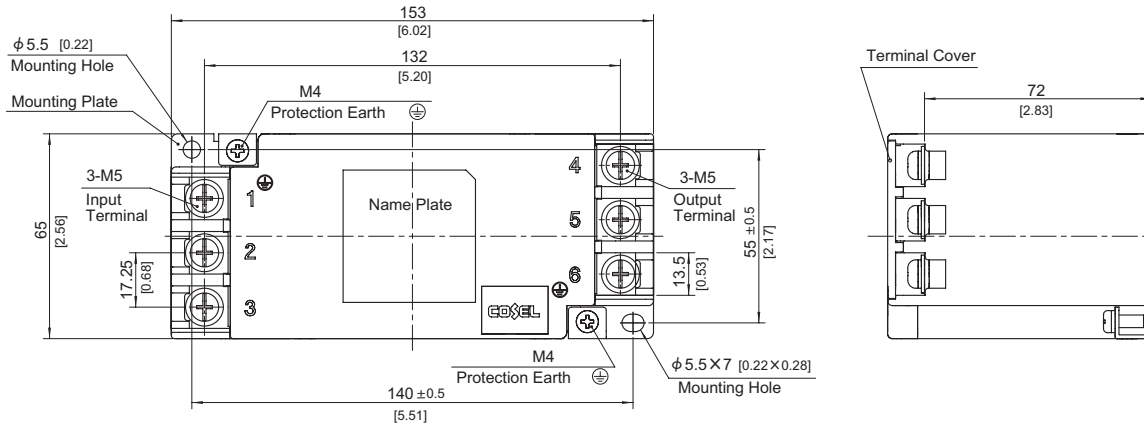

- ※ Tolerance : ± 1 [± 0.04]
- ※ Weight : 1.2kg max
- ※ Mounting Plate : Iron (surface finishing : nickel plating) $t=1.2$ [0.05]
- ※ Case : PBT
- ※ Dimensions in mm, []=inches
- ※ Terminal block screw tightening torque M5 : $3.0N \cdot m$ (30.7kgf · cm)max
- ※ Protection Earth (PE) screw tightening torque M4 : $1.6N \cdot m$ (16.9kgf · cm)max
- ※ Can not be mounted upside-down (mounted the top surface)

With switch of line to ground capacitor ON/OFF

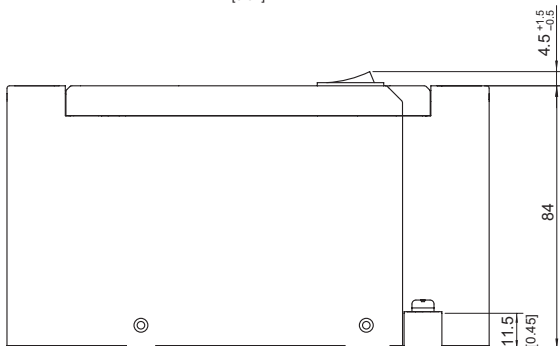
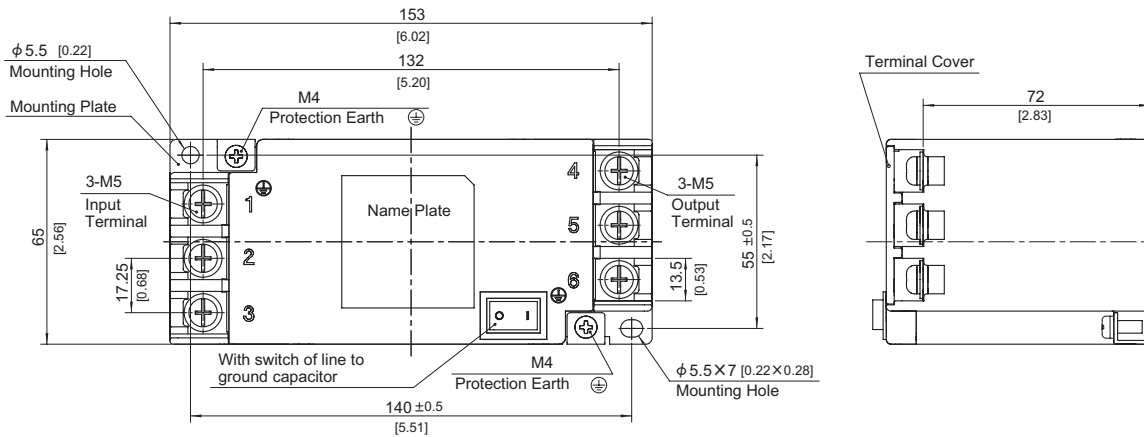

- ※ Tolerance : ± 1 [± 0.04]
- ※ Weight : 1.2kg max
- ※ Mounting Plate : Iron (surface finishing : nickel plating) $t=1.2$ [0.05]
- ※ Case : PBT
- ※ Dimensions in mm, []=inches
- ※ Terminal block screw tightening torque M5 : $3.0N \cdot m$ (30.7kgf · cm)max
- ※ Protection Earth (PE) screw tightening torque M4 : $1.6N \cdot m$ (16.9kgf · cm)max
- ※ Can not be mounted upside-down (mounted the top surface)
- ※ The switch state is OFF at shipping
- ※ Switch status ON : "I", OFF : "O"

※ HIGH LEAKAGE CURRENT
first connect to earth

FTA-40-223-H

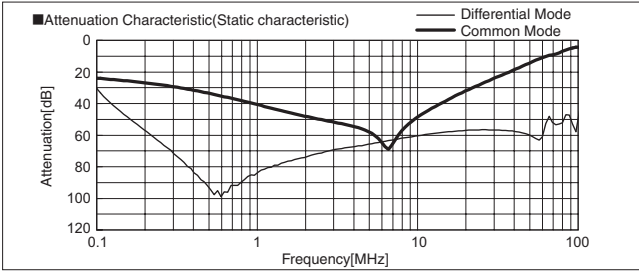

FTA-40-683-H

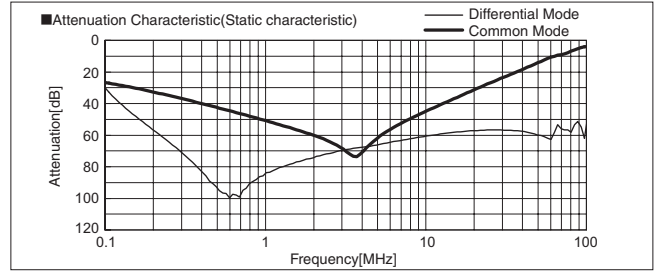

FTA-40-104-H

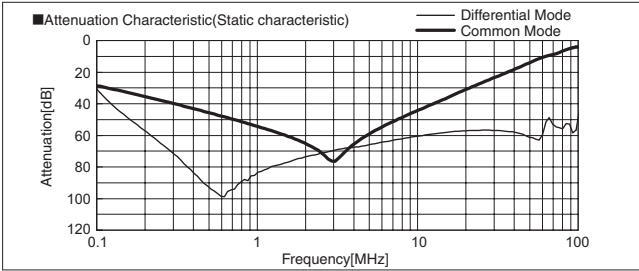

FTA-50-223-H

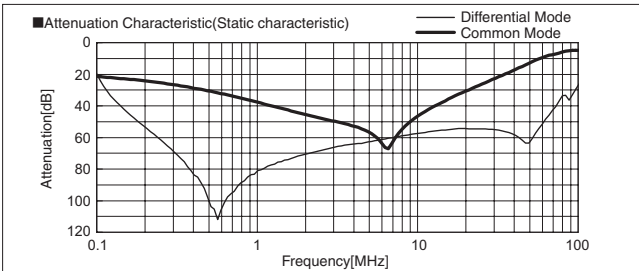

FTA-50-683-H

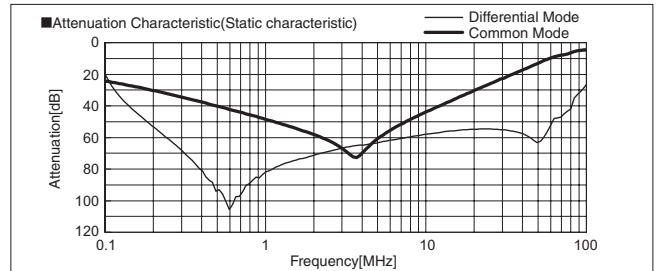

FTA-50-104-H

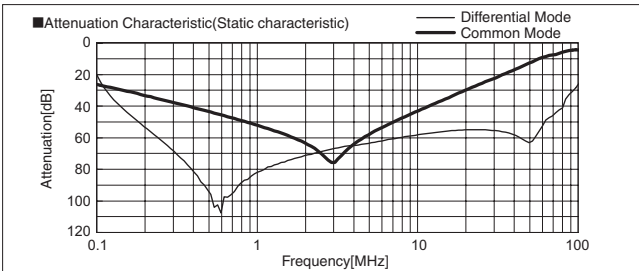

FTA-60-223-H

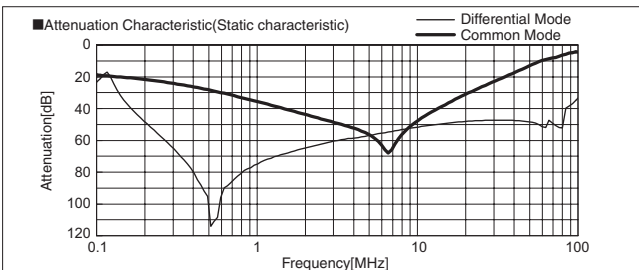

FTA-60-683-H

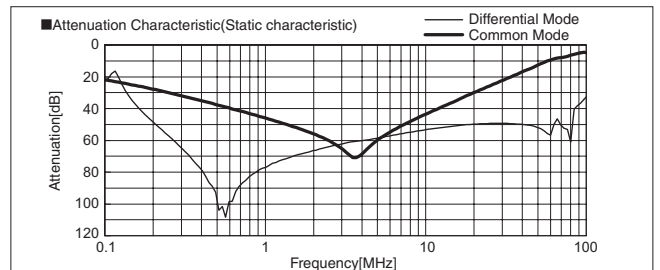

FTA-60-104-H

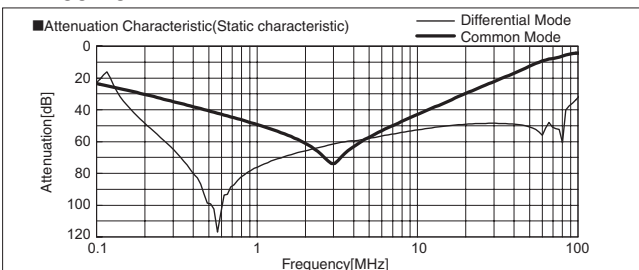

FTA series(80,100,125,150A)

FTA -80 -683 -□

① ② ③ ④

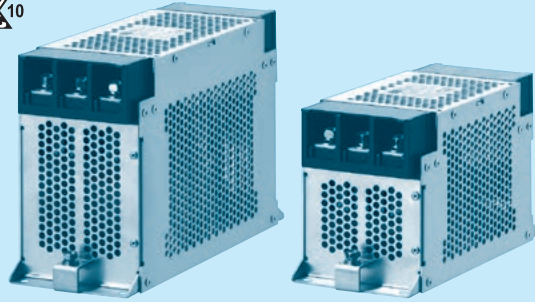

- ① Model Name
- ② Rated Current
- ③ Line to ground capacitor code: See table 1.1.

Code	Leakage Current (Input 250/500V 60Hz) (155,335 only 250/400V 60Hz)	Line to ground capacitor (nominal value)
223	1.0mA/2.0mA max	22,000pF
683	2.5mA/5.0mA max	68,000pF
104	3.5mA/7.0mA max	100,000pF
155	160mA/250mA max	1.5μF
335	320mA/500mA max	3.3μF

* When the line to ground capacitor code is different, the attenuation characteristic is different.

- ④ Option
- H: Ultra high attenuation type
"155", "335" is not applied.
- S: Hexagon socket head cap screw
(Standard type is Hexagon head screw)
- U: Improve differential mode attenuation
(Rated voltage 250V)
- G: With switch of line to ground capacitor
Only "155", "335" is applied.
- * "155" is Leakage current 160mA/250mA max when the switch state is ON (switched to "I").
50μA/80μA max when the switch state is OFF (switched to "O").
- * "335" is Leakage current 320mA/500mA max when the switch state is ON (switched to "I").
50μA/80μA max when the switch state is OFF (switched to "O").

Features of FTA series

Book type (Space-saving type)

- 1-stage filter General-purpose High-attenuation (150kHz - 1MHz)
- Selectable leakage current value, Ultra high attenuation type "155", "335" for EU
(Wye type with neutral earth system), With switch of line to ground capacitor "-G"

Specifications

No.	Items	FTA-80-683	FTA-100-683	FTA-125-683	FTA-150-683
1	Rated Voltage[V]	AC Three phase 500 (voltage range:528 max) 50/60Hz *1 *2			
2	Rated Current[A]	80	100	125	150
3	Test Voltage (Terminal-Mounting Plate)	2,500 VAC (Cutoff Current = 100mA), 1minute at room temperature and humidity *3			
4	Isolation Resistance (Terminal-Mounting Plate)	500 VDC 100MΩ min at room temperature and humidity *4			
5	Leakage current 250/500V 60Hz	2.5mA/5.0mA max			
6	DC resistance	5mΩ max	4mΩ max	3mΩ max	3mΩ max
7	Safety agency approval temperatures	-25 to +85°C (Refer to Derating Curve)			
8	Operating temperature	-40 to +85°C (Refer to Derating Curve)			
9	Operating humidity	20 to 95%RH (Non condensing)			
10	Storage temperature/humidity	-40 to +85°C/20 to 95%RH (Non condensing)			
11	Vibration	10 to 55Hz, 19.6m/s ² (2G), 3min. Period, 1hour each X, Y and Z axis			
12	Impact	196.1m/s ² (20G), 11ms Once each X, Y and Z axis			
13	Safety agency approvals	UL1283, CSA C22.2 No.8 (C-UL), DIN EN60939 VDE0565 Teil3-1, ENEC			
14	Case size (without projection)	100 X 130 X 210 mm (W X H X D) (Option: -G refer to external view)			100 X 170 X 260 mm (W X H X D) (Option: -G refer to external view)
		[3.94 X 5.12 X 8.27 inches]			[3.94 X 6.69 X 10.24 inches]
15	Weight	3.1kg max			4.2kg max

*1 Only capacitor code and option "155", "335", Three Phase Δ-connection:400 (440 max), Wye-connection:500(528 max)

*2 Only option "U", Three Phase 250(275 max)

*3 Only capacitor code and option "155", "335", 2,800VDC (Cutoff Current = 10mA), 1minute at room temperature and humidity.

*4 Only capacitor code and option "155", "335", Isolation resistance specification is deleted.

Circuit Diagram

(1) Line to ground capacitor code : 223, 683, 104

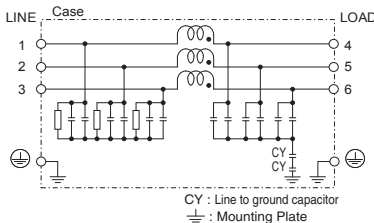

(2) Line to ground capacitor code : 155, 335

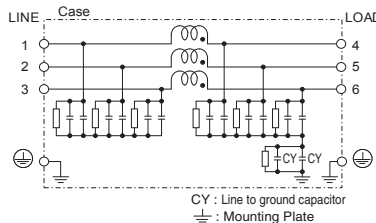

(3) Line to ground capacitor code : 223, 683, 104
Option : U

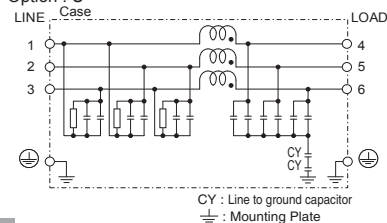

(4) Line to ground capacitor code : 155, 335
Option : U

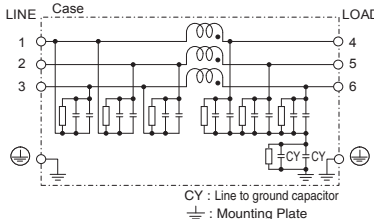

(5) Line to ground capacitor code : 155, 335
Option : G

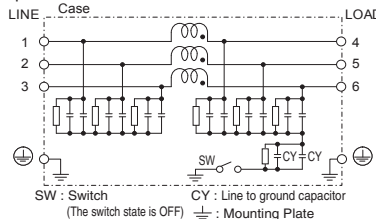

Derating Curve

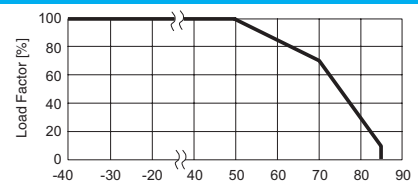

* Keep free ventilation holes for cooling.

External view

FTA-80 / FTA-100 / FTA-125

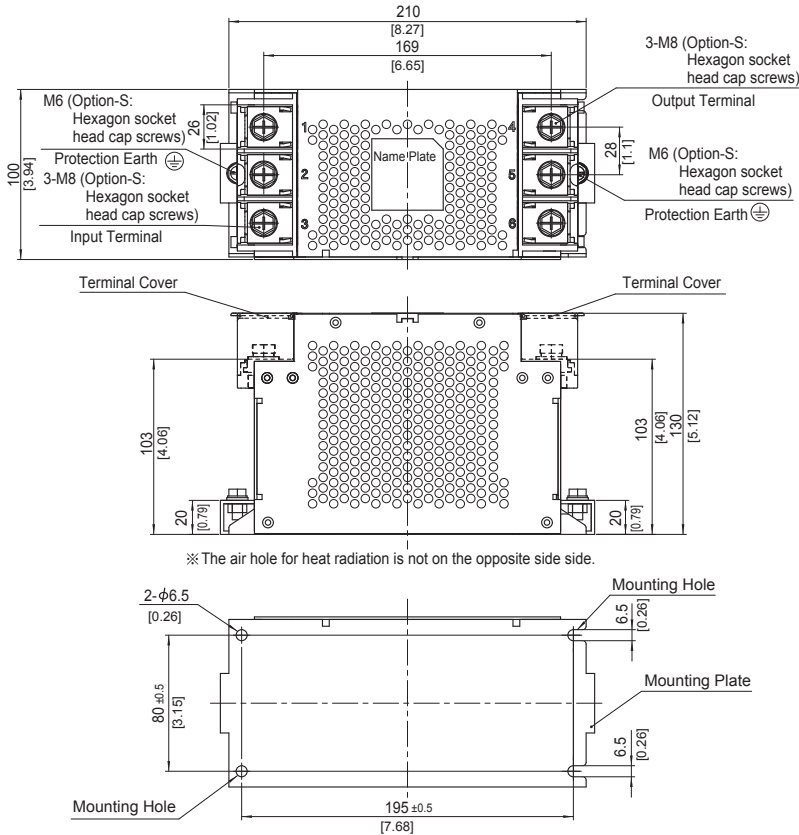

- ※ Tolerance : ±1 [±0.04]
- ※ Weight : 3.1kg max
- ※ Mounting Plate : Aluminum t=2.0 [0.08]
- ※ Dimensions in mm, []=inches
- ※ Terminal block screw tightening torque
M8 : 9.2N · m(93.9kgf · cm)max
- ※ Protection Earth (PE) screw tightening torque
M6 : 5.8N · m(59.2kgf · cm)max
- ※ Can not be mounted upside-down
(mounted the top surface)
- ※ Keep free ventilation holes for cooling

FTA-80 / FTA-100 / FTA-125 with switch of line to ground capacitor ON/OFF

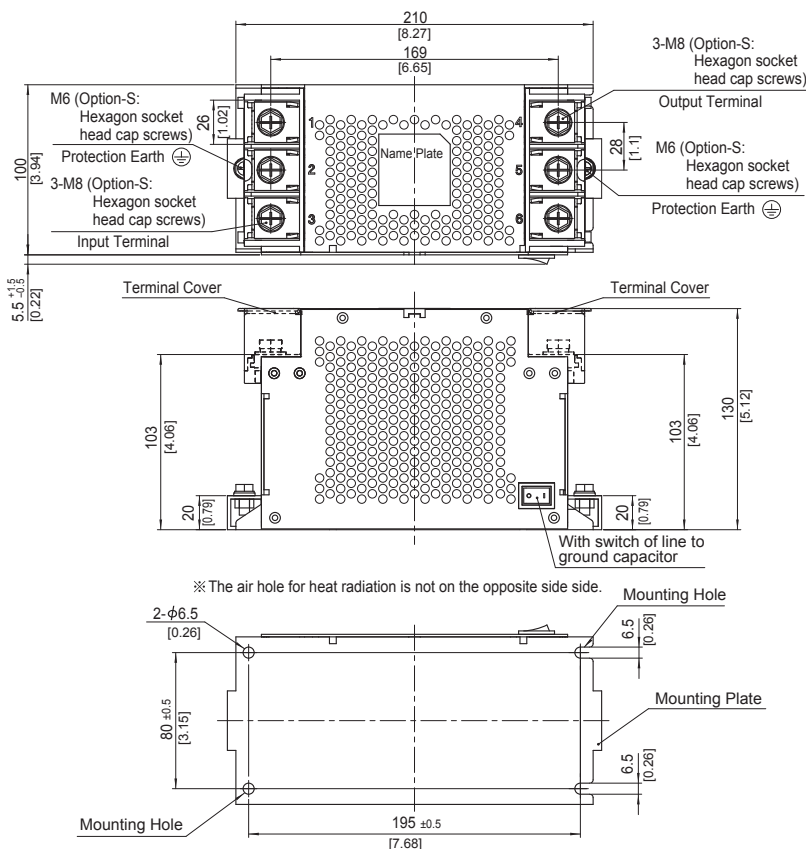

- ※ Tolerance : ±1 [±0.04]
- ※ Weight : 3.1kg max
- ※ Mounting Plate : Aluminum t=2.0 [0.08]
- ※ Dimensions in mm, []=inches
- ※ Terminal block screw tightening torque
M8 : 9.2N · m(93.9kgf · cm)max
- ※ Protection Earth (PE) screw tightening torque
M6 : 5.8N · m(59.2kgf · cm)max
- ※ Can not be mounted upside-down
(mounted the top surface)
- ※ Keep free ventilation holes for cooling
- ※ The switch state is OFF at shipping
- ※ Switch status ON : "I", OFF : "O"
- ※ HIGH LEAKAGE CURRENT
first connect to earth

External view

FTA-150

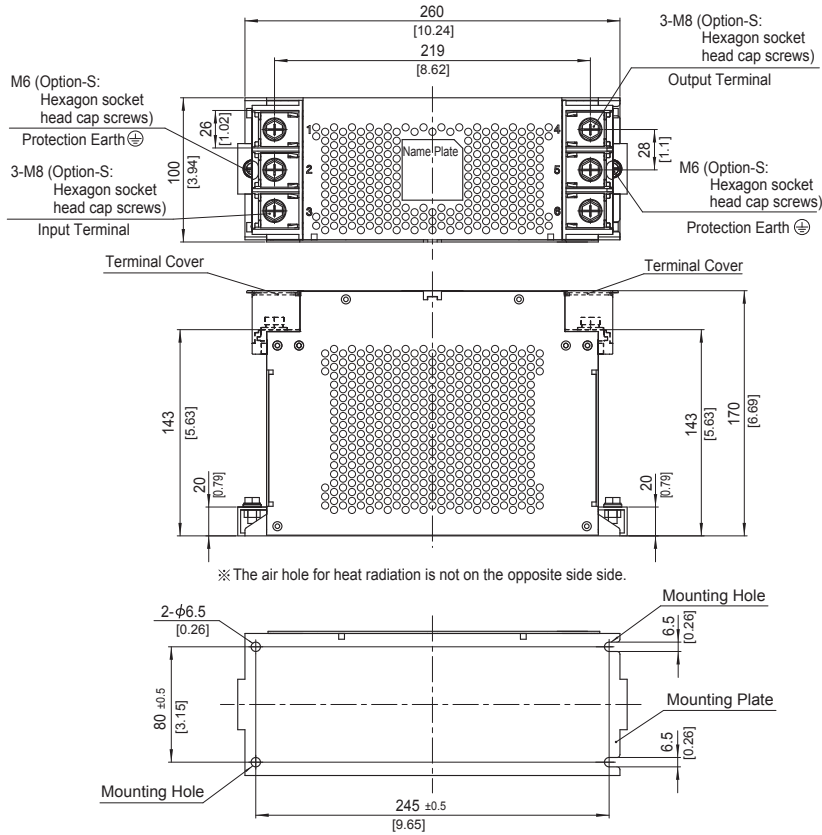

- ※ Tolerance : ±1 [±0.04]
- ※ Weight : 4.2kg max
- ※ Mounting Plate : Aluminum t=2.0 [0.08]
- ※ Dimensions in mm, []=inches
- ※ Terminal block screw tightening torque
M8 : 9.2N · m(93.9kgf · cm)max
- ※ Protection Earth (PE) screw tightening torque
M6 : 5.8N · m(59.2kgf · cm)max
- ※ Can not be mounted upside-down (mounted the top surface)
- ※ Keep free ventilation holes for cooling

FTA-150 with switch of line to ground capacitor ON/OFF

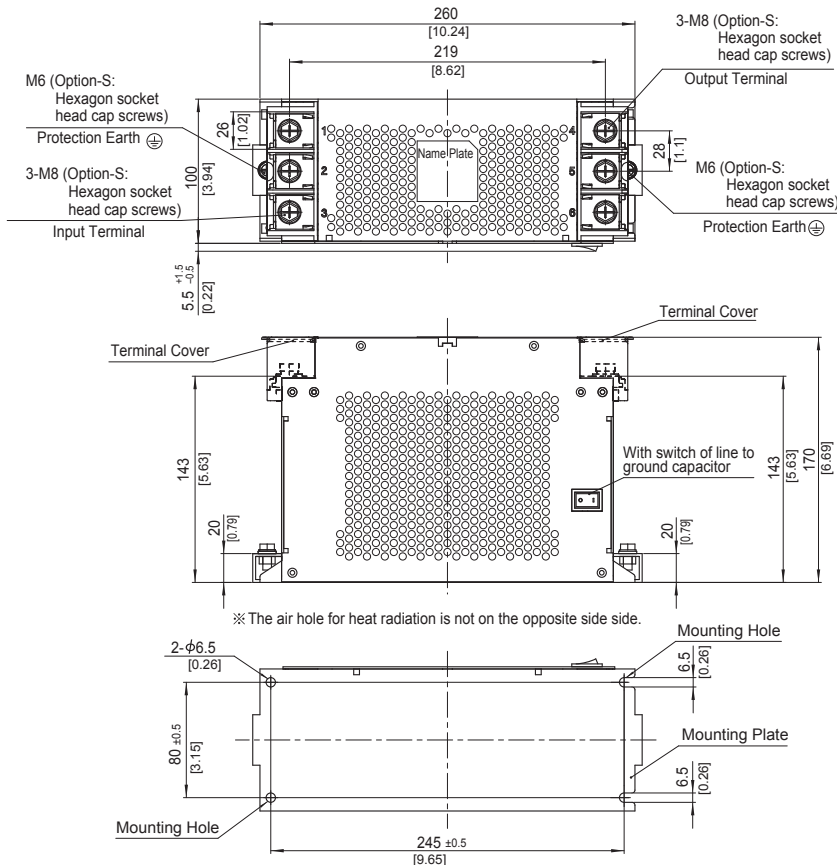

- ※ Tolerance : ±1 [±0.04]
- ※ Weight : 4.2kg max
- ※ Mounting Plate : Aluminum t=2.0 [0.08]
- ※ Dimensions in mm, []=inches
- ※ Terminal block screw tightening torque
M8 : 9.2N · m(93.9kgf · cm)max
- ※ Protection Earth (PE) screw tightening torque
M6 : 5.8N · m(59.2kgf · cm)max
- ※ Can not be mounted upside-down (mounted the top surface)
- ※ Keep free ventilation holes for cooling
- ※ The switch state is OFF at shipping
- ※ Switch status ON : " | ", OFF : " O "
- ※ HIGH LEAKAGE CURRENT first connect to earth

FTA-80-223

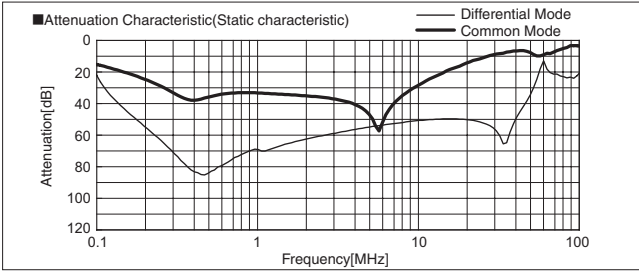

FTA-80-683

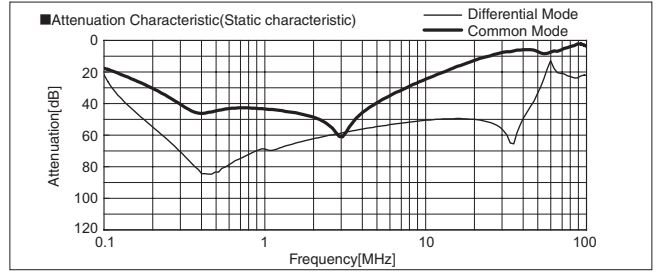

FTA-80-104

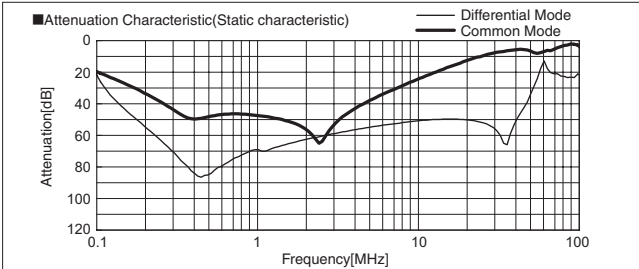

FTA-80-155

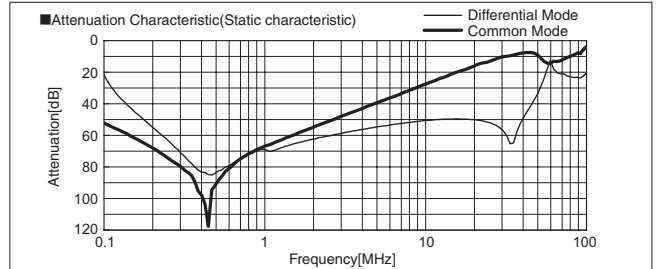

FTA-80-335

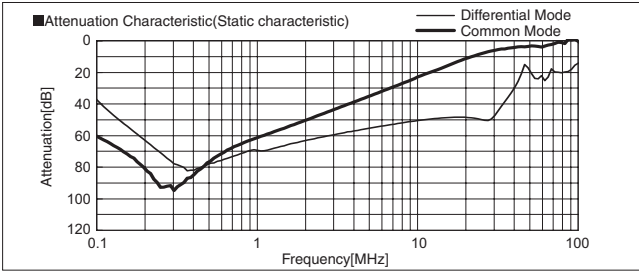

FTA-100-223

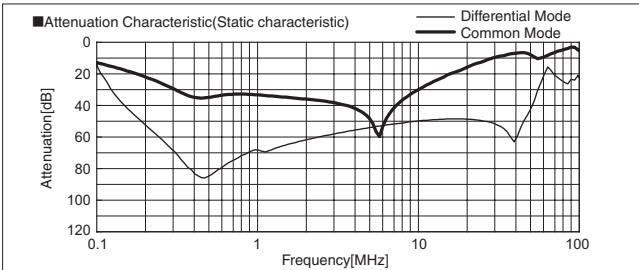

FTA-100-683

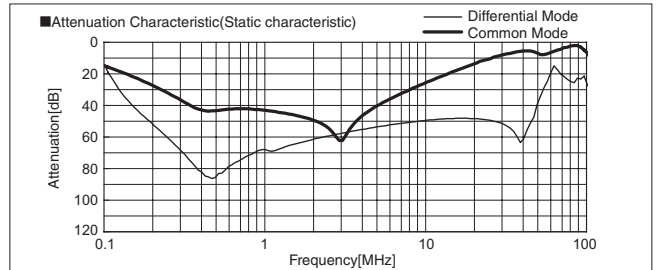

FTA-100-104

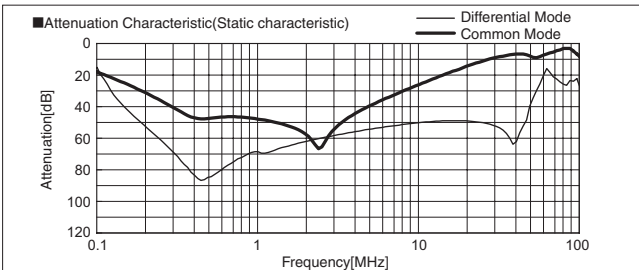

FTA-100-155

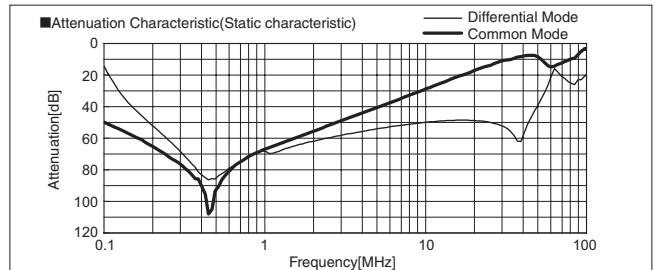

FTA-100-335

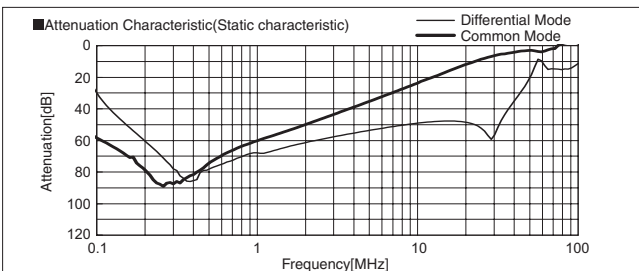

FTA-125-223

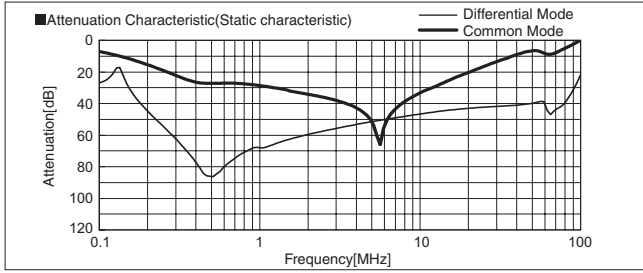

FTA-125-683

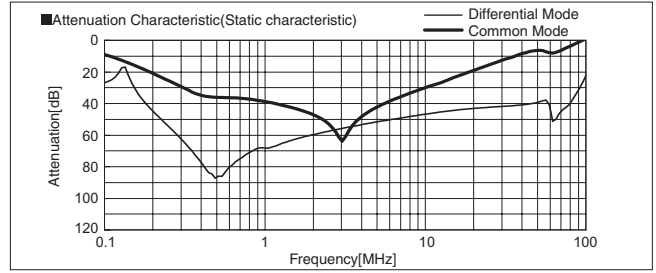

FTA-125-104

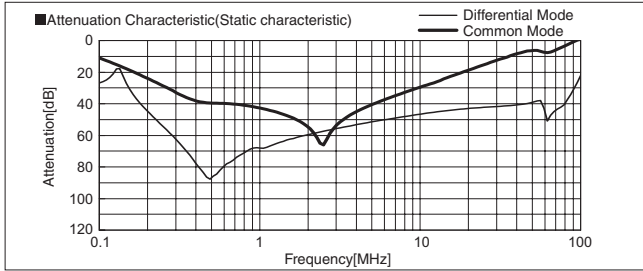

FTA-125-155

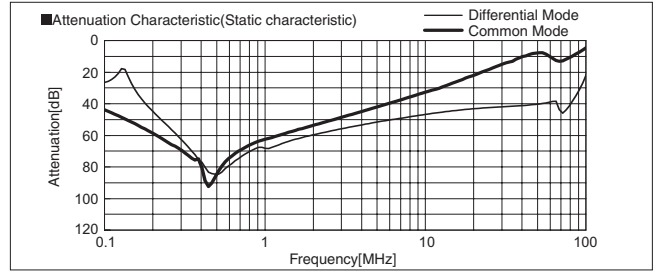

FTA-125-335

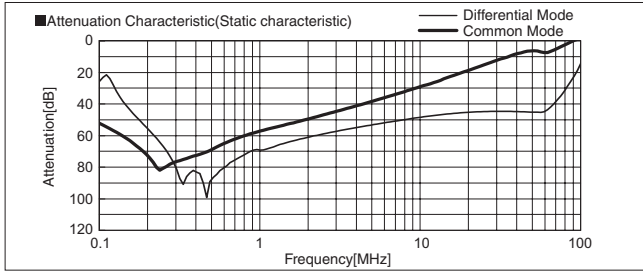

FTA-150-223

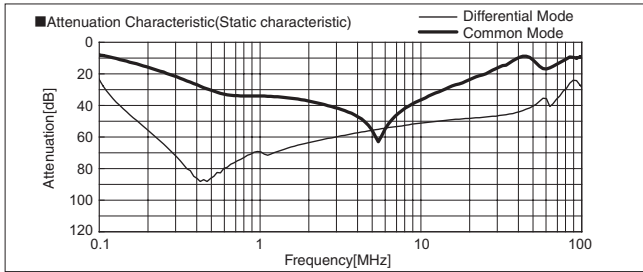

FTA-150-683

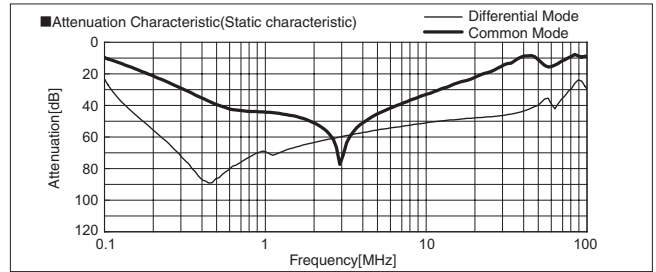

FTA-150-104

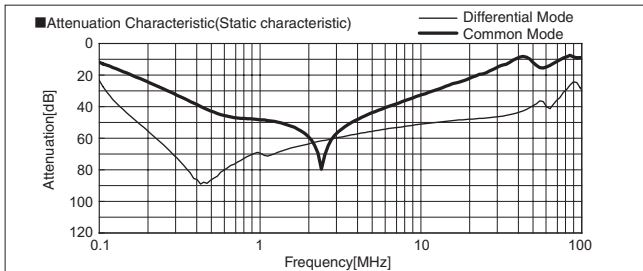

FTA-150-155

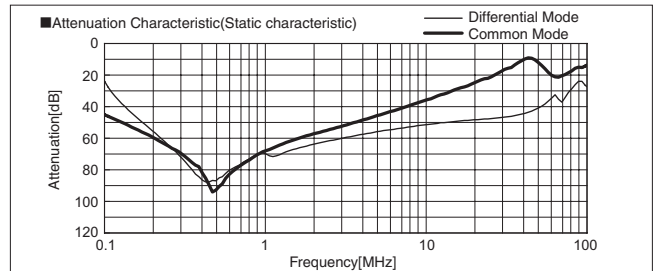

FTA-150-335

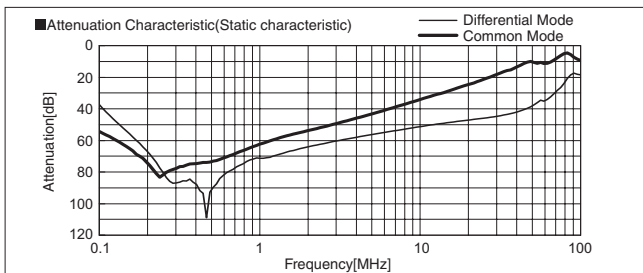

FTA-80-223-H

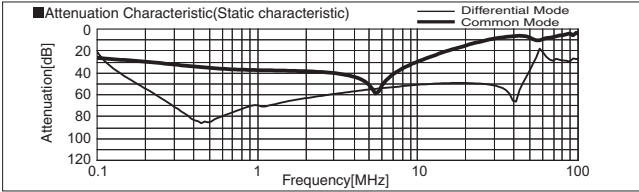

FTA-80-683-H

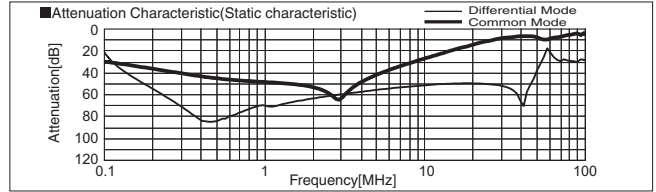

FTA-80-104-H

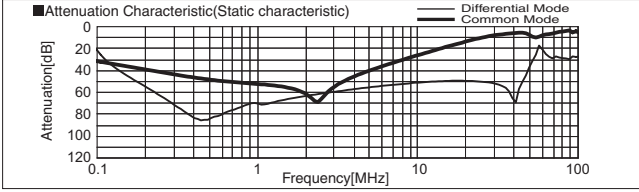

FTA-100-223-H

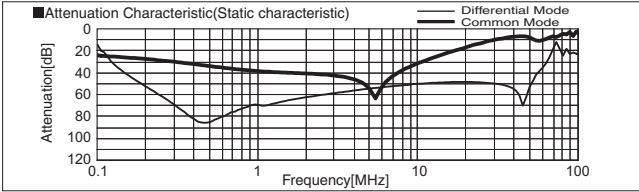

FTA-100-683-H

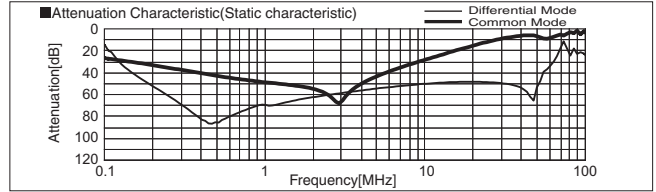

FTA-100-104-H

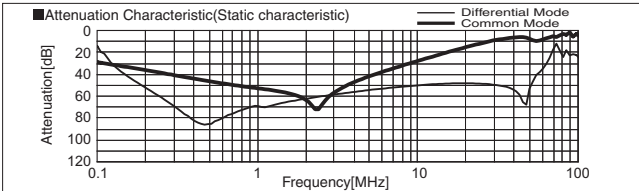

FTA-125-223-H

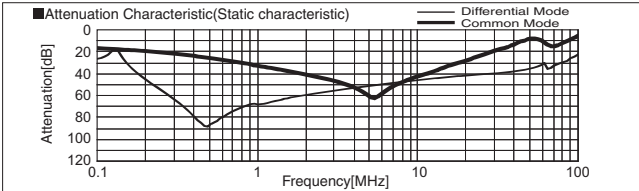

FTA-125-683-H

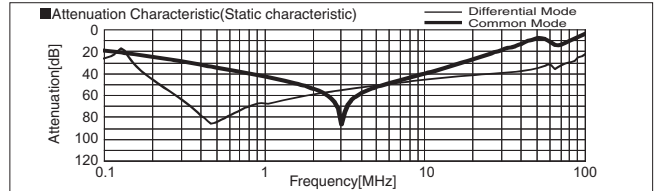

FTA-125-104-H

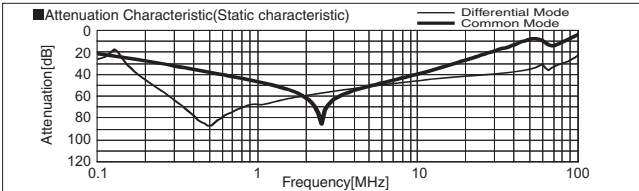

FTA-150-223-H

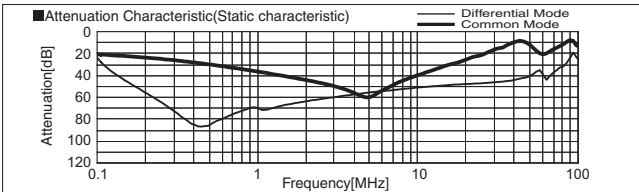

FTA-150-683-H

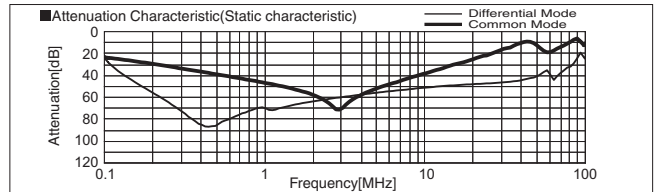

FTA-150-104-H

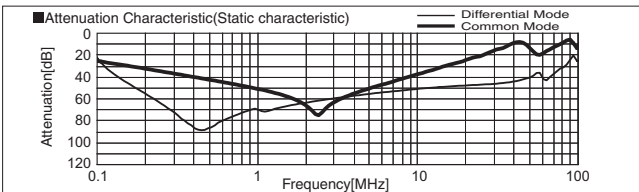

FTA-80-223-U

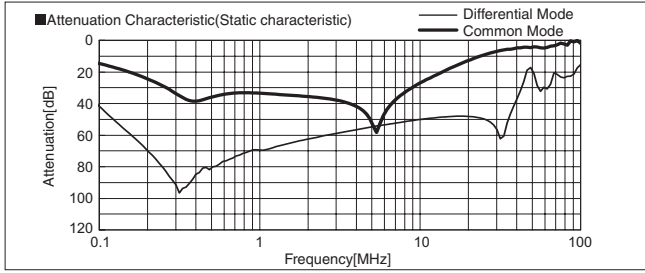

FTA-80-683-U

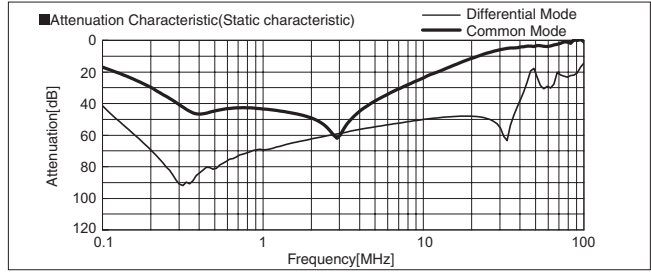

FTA-80-104-U

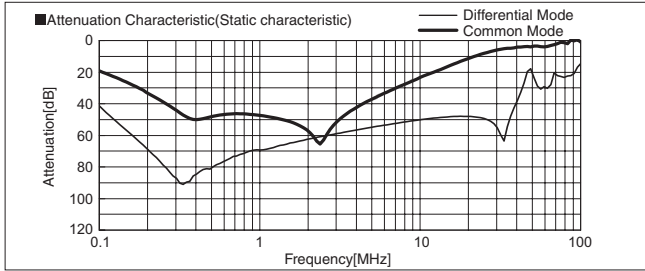

FTA-80-155-U

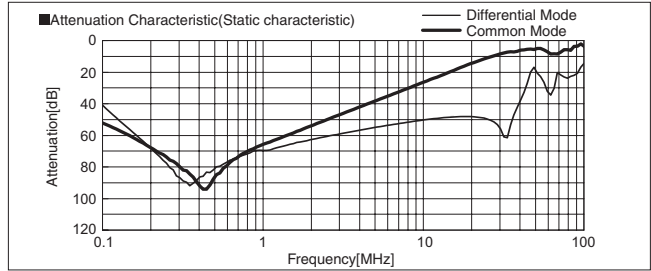

FTA-80-335-U

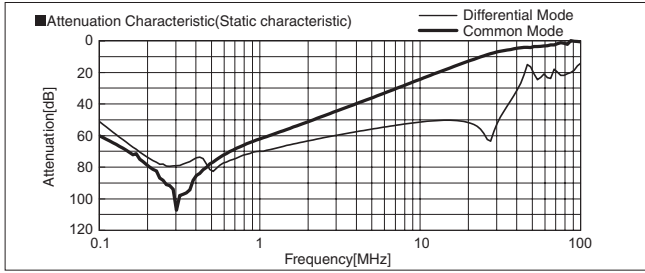

FTA-100-223-U

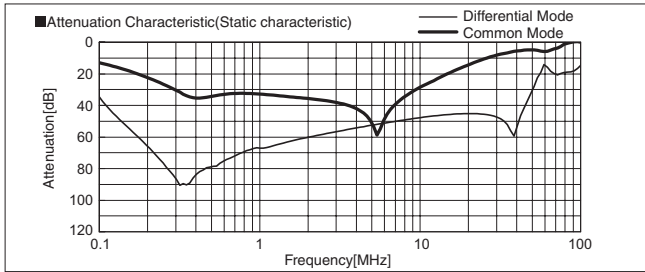

FTA-100-683-U

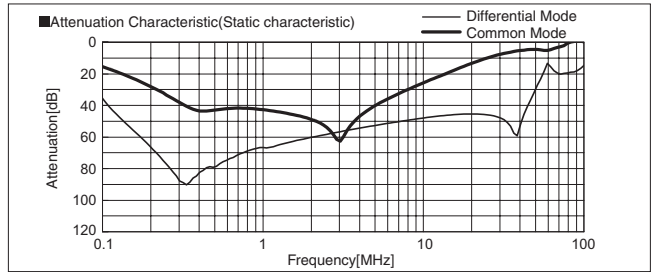

FTA-100-104-U

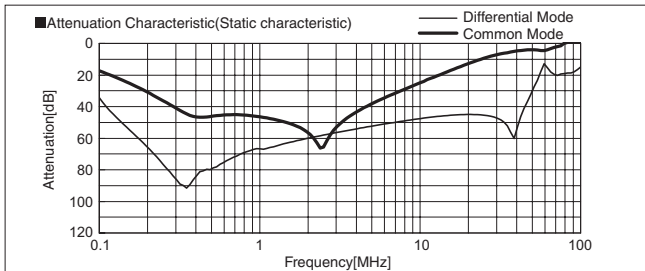

FTA-100-155-U

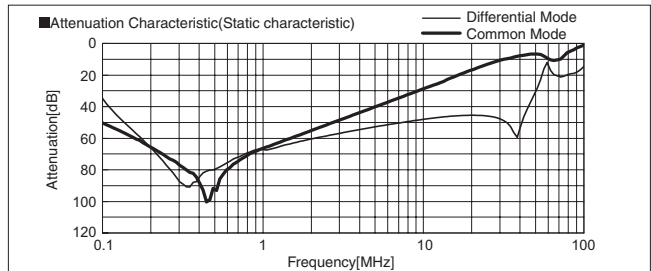

FTA-100-335-U

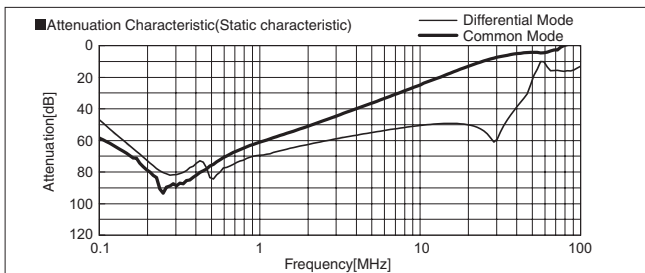

YAC series(25,36,64,80A)

YAC -25 -685

① ② ③

- ① Series Name
- ② Rated Current
- ③ Line to Ground Capacitor Code: See Table 1.1.

Table 1.1. Line to Ground Capacitor Code

Code	Leakage Current Y-Connection Input 500V 60Hz	Line to Ground Capacitor (Nominal Value)
685	10.7mA typ *1 55mA max *2	6.8μF

*1 At normal operation with applying 10V in between N (N') and FG (According to IEC60939).

*2 At the worst case under normal operation.



Features of YAC series

- Three-Phase Four-Wire System EMI/EMC Filter ideal for High-power office equipment and Energy storage systems
- Suitable for 150kHz to 1MHz conduction noise reduction
- Product lineup that can flexibly respond to system and capacity changes in a compact/same body size

Specifications

No.	Items	YAC-25-685	YAC-36-685	YAC-64-685	YAC-80-685
1	Rated Voltage[VAC]	Three-Phase Four-Wire System Y-Connection 500/289 (Voltage Range:528/305 max) 50/60Hz *3			
2	Rated Current[A]	25	36	64	80
3	Test Voltage (Terminal-Mounting Plate)	2,800 VDC (Cutoff Current = 10mA), 1minute at room temperature and humidity			
4	Isolation Resistance (Terminal-Mounting Plate)	500 VDC 5MΩ min. at room temperature and humidity			
5	Leakage Current 500V 60Hz (Y-Connection)	10.7mA typ *1			
		55mA max *2			
6	DC Resistance	15mΩ max	10mΩ max	3.5mΩ max	2.5mΩ max
7	Operating Temperature/Humidity	-40 to +85°C (Refer to Derating Curve)/20 to 95%RH (Non condensing)			
8	Storage Temperature/Humidity	-40 to +85°C/20 to 95%RH (Non condensing)			
9	Vibration	10 to 55Hz, 19.6m/s ² (2G), 3min. Period, 1hour each X, Y and Z axis			
10	Impact	196.1m/s ² (20G), 11ms Once each X, Y and Z axis			
11	Safety Agency Approvals	UL60939 [Overvoltage Category : III Altitude : 3000m] , CSA C22. 2 No. 8 (C-UL) EN60939 (DEMKO) [Overvoltage Category : III Altitude : 3000m] , ENEC			
12	Case Size (Without Projection)	100×88×179mm (W×H×D)			
		[3.94×3.46×7.05 inches] (W×H×D)			
13	Weight	1.7kg max			

*3 Voltage indicates "Line Voltage/Phase Voltage".

Circuit Diagram

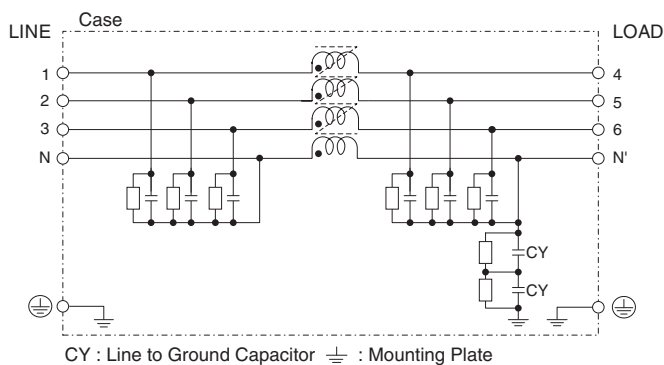

Derating Curve

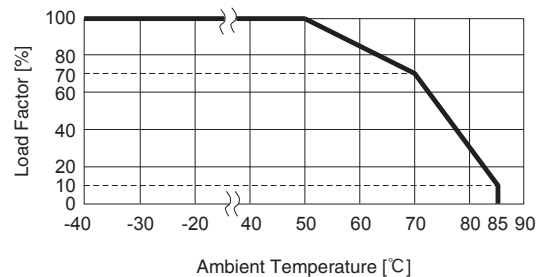

*Keep free ventilation holes for cooling.

External view

This product is shipped with the terminal cover retracted inside the unit.

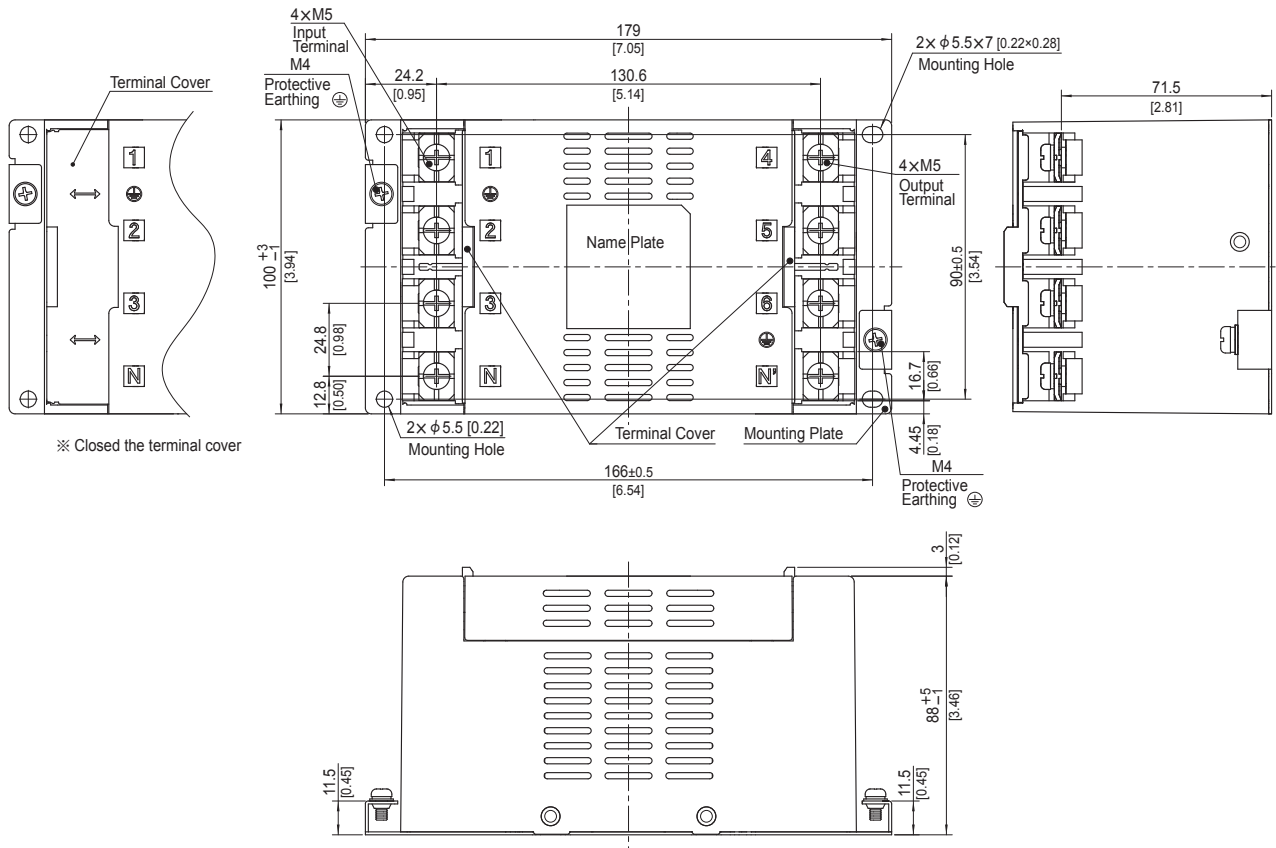

- ※ Dimensions in mm, [] = inches
- ※ Tolerance : \pm 1 [\pm 0.04]
- ※ Weight : 1.7kg max
- ※ Mounting Plate : Galvanized Steel board t=1.0 [0.04]
- ※ Case Material : PBT
- ※ Terminal block screw tightening torque M5 : 3.0N · m max
- ※ Protective Earthing (PE) screw tightening torque M4 : 1.6N · m max
- ※ Can not be mounted upside-down. (mounted the top surface)
- ※ Keep free ventilation holes for cooling.

YAC-25-685

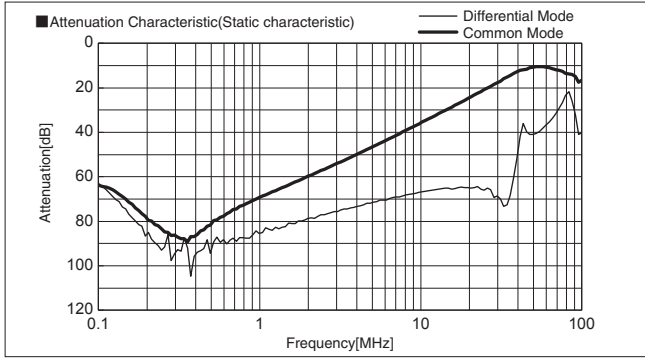

YAC-36-685

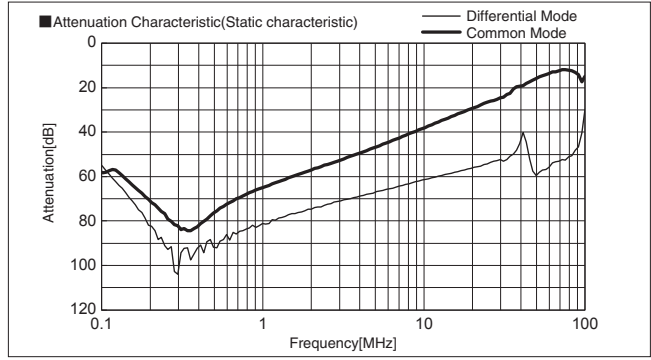

YAC-64-685

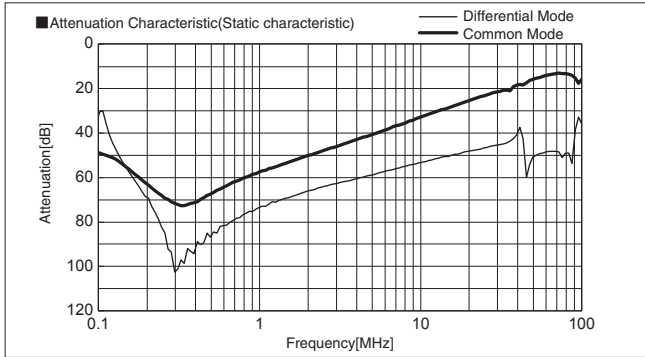

YAC-80-685

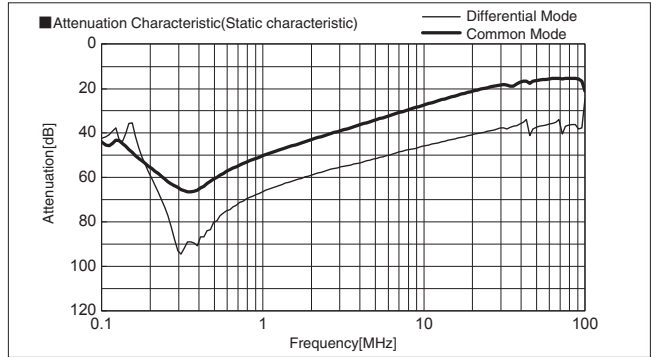

TBC series(50,60,80,100,150A)

TBC -50 -683

① ② ③

- ① Model Name
- ② Rated Current
- ③ Line to ground capacitor code: See table 1.1.

table 1.1 Line to ground capacitor code

Code	Leakage Current (Input 250/500V 60Hz)	Line to ground capacitor (nominal value)
223	1.0mA/2.0mA max	22,000pF
683	2.5mA/5.0mA max	68,000pF
104	3.5mA/7.0mA max	100,000pF

* When the line to ground capacitor code is different, the attenuation characteristic is different.



*Link to www.cosel.co.jp/en for the latest product information.

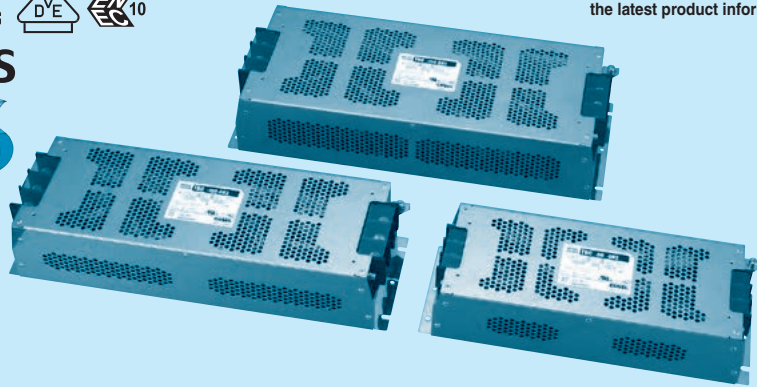

Features of TBC series

High-attenuation type of common mode noise from 150kHz to 1MHz (2-stage filter)

- Three phase rated voltage 500 VAC (voltage range:528V max)
- Selectable leakage current value

Specifications

No.	Items	TBC-50-683	TBC-60-683	TBC-80-683	TBC-100-683	TBC-150-683
1	Rated Voltage[V]	AC Three Phase 500 (voltage range:528 max) 50/60Hz				
2	Rated Current[A]	50	60	80	100	150
3	Test Voltage (Terminal-Mounting Plate)	2,500 VAC (Cutoff Current = 100mA), 1minute at room temperature and humidity				
4	Isolation Resistance (Terminal-Mounting Plate)	500 VDC 100MΩ min at room temperature and humidity				
5	Leakage current 250/500V 60Hz	2.5mA/5.0mA max				
6	DC resistance	14mΩ max	10mΩ max	10mΩ max	8mΩ max	6mΩ max
7	Safety agency approval temperatures	-25 to +85°C (Refer to Derating Curve)				
8	Operating temperature	-40 to +85°C (Refer to Derating Curve)				
9	Operating humidity	20 to 95%RH (Non condensing)				
10	Storage temperature/humidity	-40 to +85°C/20 to 95%RH (Non condensing)				
11	Vibration	10 to 55Hz, 19.6m/s ² (2G), 3min. Period, 1hour each X, Y and Z axis				
12	Impact	196.1m/s ² (20G), 11ms Once each X, Y and Z axis				
13	Safety agency approvals	UL1283, CSA C22.2 No.8 (C-UL), DIN EN60939 VDE0565 Teil3-1, ENEC				
14	Case size (without projection)	140×80×374 mm (W×H×D)		150×92×456 mm (W×H×D)		190×92×482 mm (W×H×D)
		[5.51×3.15×14.72 inches]		[5.91×3.62×17.95 inches]		[7.48×3.62×18.98 inches]
15	Weight	4.3kg max		7.7kg max		9.6kg max

Circuit Diagram

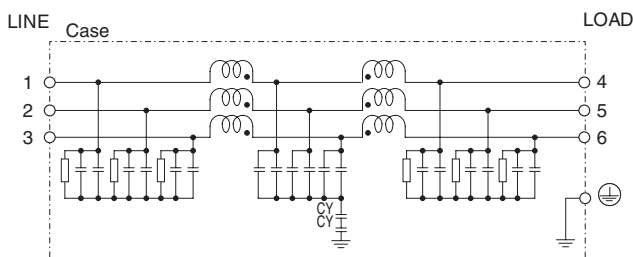

CY : Line to ground capacitor \perp : Mounting Plate

Derating Curve

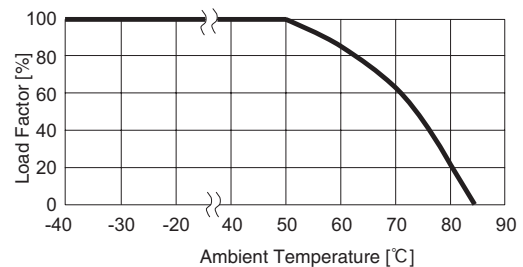

* Keep free ventilation holes for cooling.

External view

TBC-50-□□□ / TBC-60-□□□

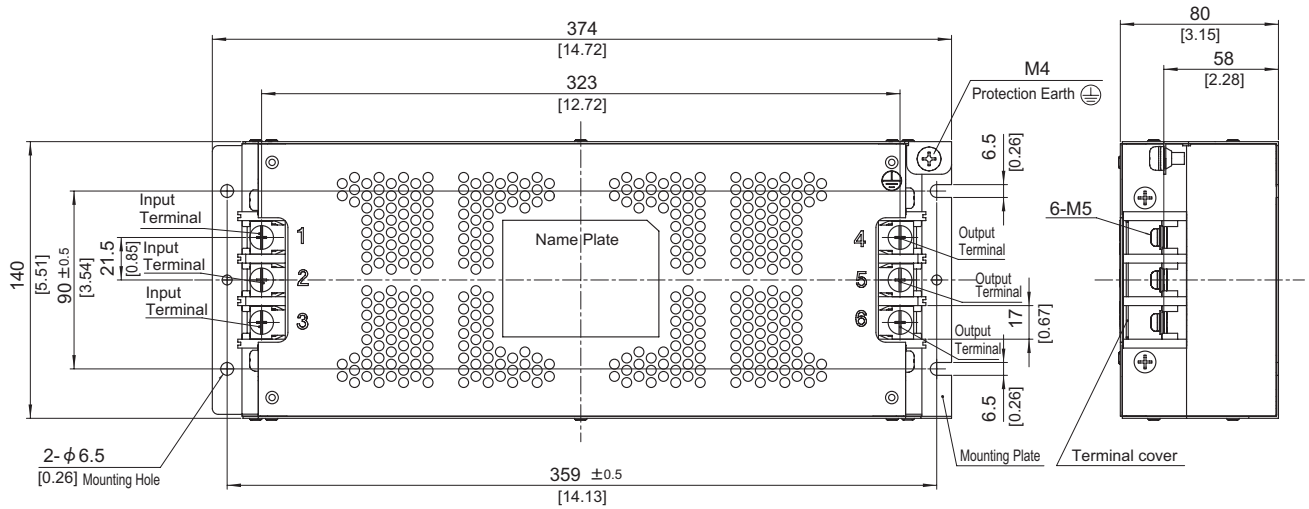

※ Can not be mounted upside-down.
(mounted the top surface)

- ※ Tolerance : ± 1 [± 0.04]
- ※ Weight : 4.3kg max
- ※ Chassis Material : Stainless steel $t=1.0$ [0.04]
- ※ Dimensions in mm, []=inches
- ※ Terminal block screw tightening torque M5:3.0N · m (30.7kgf · cm) max
- ※ Protection Earth screw tightening torque M4:1.6N · m (16.9kgf · cm) max

TBC-80-□□□ / TBC-100-□□□

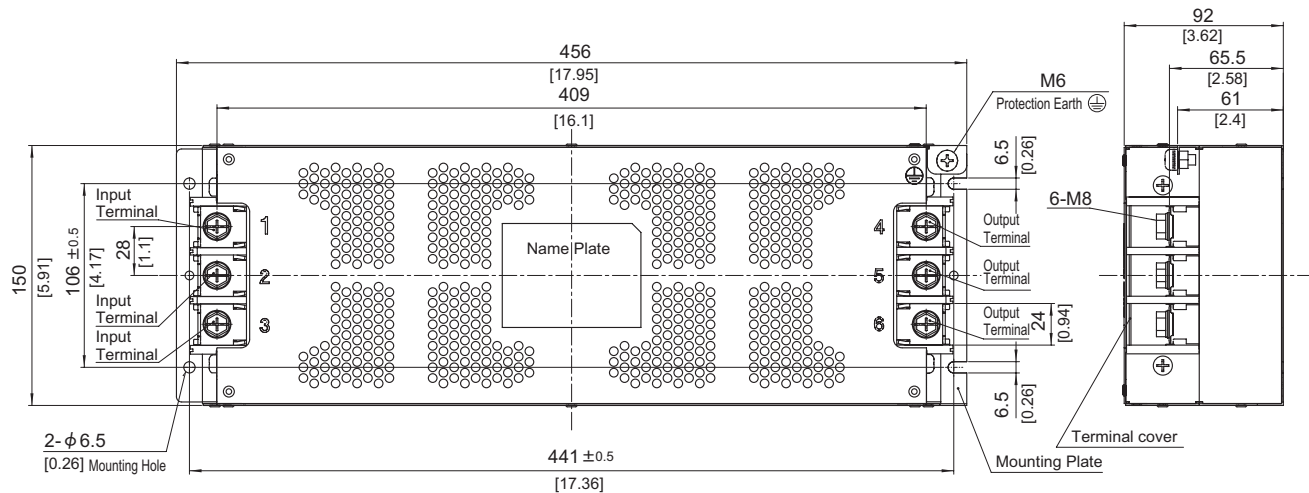

※ Can not be mounted upside-down.
(mounted the top surface)

- ※ Tolerance : ± 1 [± 0.04]
- ※ Weight : 7.7kg max
- ※ Chassis Material : Stainless steel $t=1.0$ [0.04]
- ※ Dimensions in mm, []=inches
- ※ Terminal block screw tightening torque M8:9.2N · m (93.9kgf · cm) max
- ※ Protection Earth screw tightening torque M6:5.8N · m (59.2kgf · cm) max

External view

TBC-150-□□□

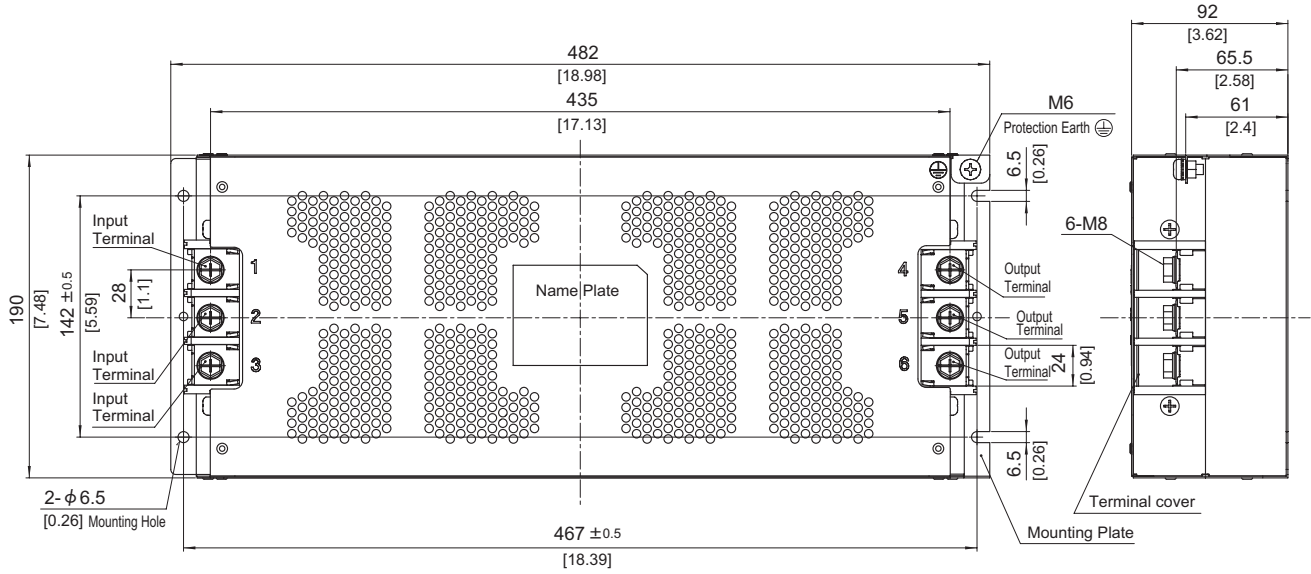

※ Can not be mounted upside-down.
(mounted the top surface)

- ※ Tolerance : ±1 [±0.04]
- ※ Weight : 9.6kg max
- ※ Chassis Material : Stainless steel t=1.0 [0.04]
- ※ Dimensions in mm, []=inches
- ※ Terminal block screw tightening torque M8:9.2N · m (93.9kgf · cm) max
- ※ Protection Earth screw tightening torque M6:5.8N · m (59.2kgf · cm) max

TBC-50-223

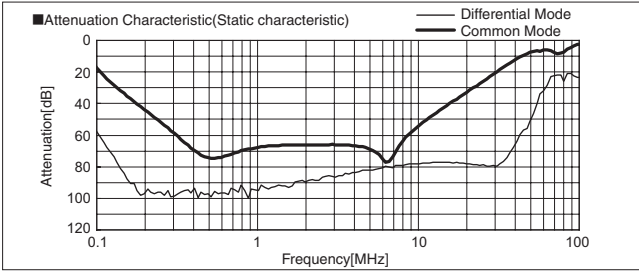

TBC-50-683

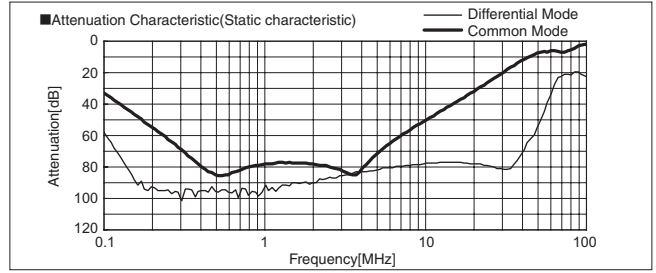

TBC-50-104

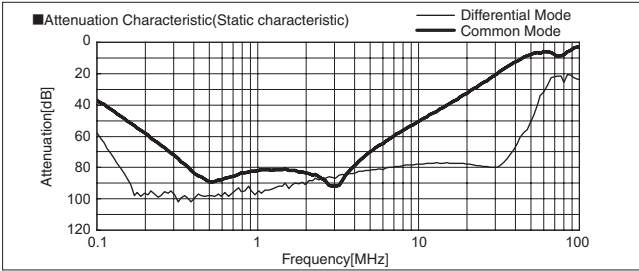

TBC-100-223

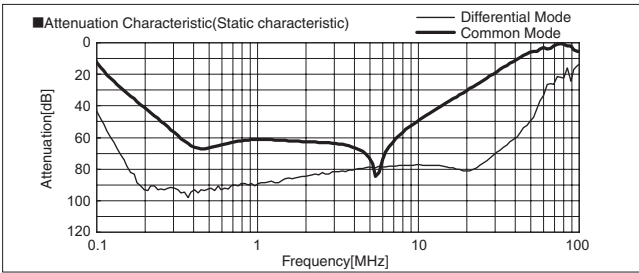

TBC-100-683

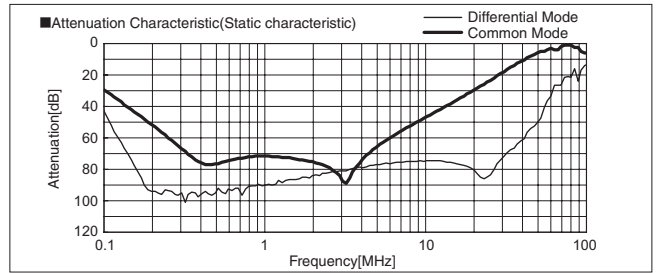

TBC-100-104

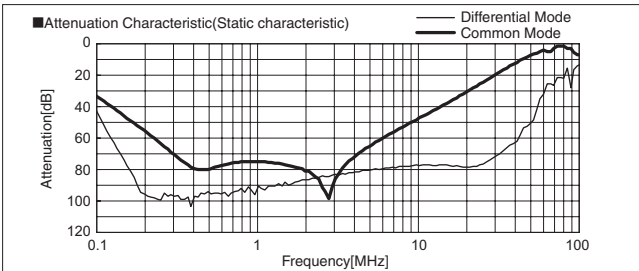

TBC-150-223

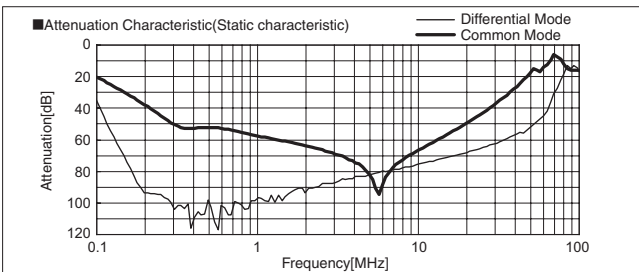

TBC-150-683

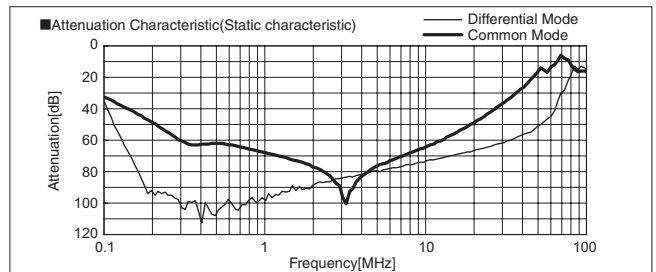

TBC-150-104

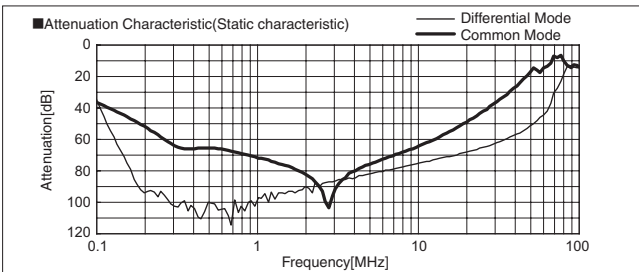

TBC series(200,250,300A)

TBC -200 -683

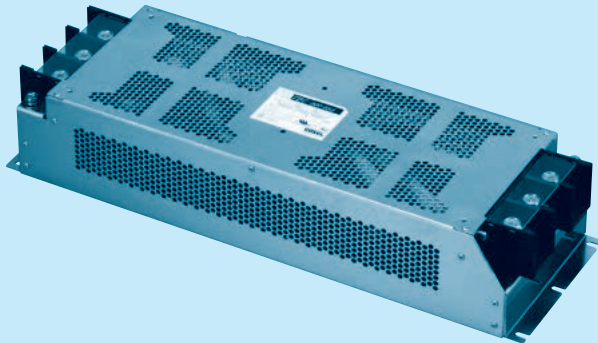

- ① Model Name
- ② Rated Current
- ③ Line to ground capacitor code: See table 1.1.

table 1.1 Line to ground capacitor code

Code	Leakage Current (Input 250/500V 60Hz)	Line to ground capacitor (nominal value)
223	1.0mA/2.0mA max	22,000pF
683	2.5mA/5.0mA max	68,000pF
104	3.5mA/7.0mA max	100,000pF

* When the line to ground capacitor code is different, the attenuation characteristic is different.

Features of TBC series

High-attenuation type of common mode noise from 150kHz to 1MHz (2-stage filter)

- Three phase rated voltage 500 VAC (voltage range:528V max)
- Selectable leakage current value

Specifications

No.	Items	TBC-200-683	TBC-250-683	TBC-300-683
1	Rated Voltage[V]	AC Three Phase 500 (voltage range:528 max) 50/60Hz		
2	Rated Current[A]	200	250	300
3	Test Voltage (Terminal-Mounting Plate)	2,500 VAC (Cutoff Current = 100mA), 1minute at room temperature and humidity		
4	Isolation Resistance (Terminal-Mounting Plate)	500 VDC 100MΩ min at room temperature and humidity		
5	Leakage current 250/500V 60Hz	2.5mA/5.0mA max		
6	DC resistance	4mΩ max	3mΩ max	2mΩ max
7	Safety agency approval temperatures	-25 to +85°C (Refer to Derating Curve)		
8	Operating temperature	-40 to +85°C (Refer to Derating Curve)		
9	Operating humidity	20 to 95%RH (Non condensing)		
10	Storage temperature/humidity	-40 to +85°C/20 to 95%RH (Non condensing)		
11	Vibration	10 to 55Hz, 19.6m/s ² (2G), 3min. Period, 1hour each X, Y and Z axis		
12	Impact	196.1m/s ² (20G), 11ms Once each X, Y and Z axis		
13	Safety agency approvals	UL1283, CSA C22.2 No.8 (C-UL) , DIN EN60939 VDE0565 Teil3-1, ENEC		
14	Case size (without projection)	190 X 110 X 580 mm [7.48 X 4.33 X 22.83 inches] (W X H X D)		
15	Weight	13.0kg max		

Circuit Diagram

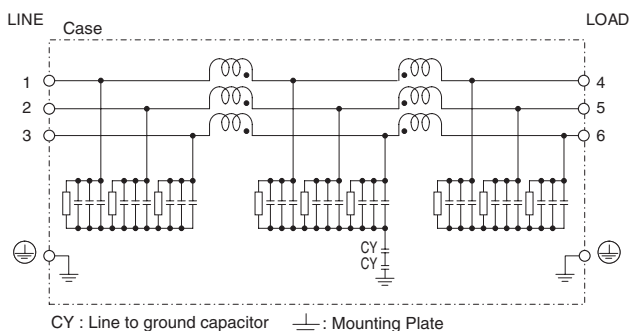

Derating Curve

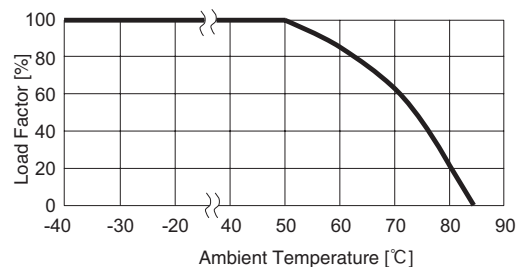

* Keep free ventilation holes for cooling.

External view

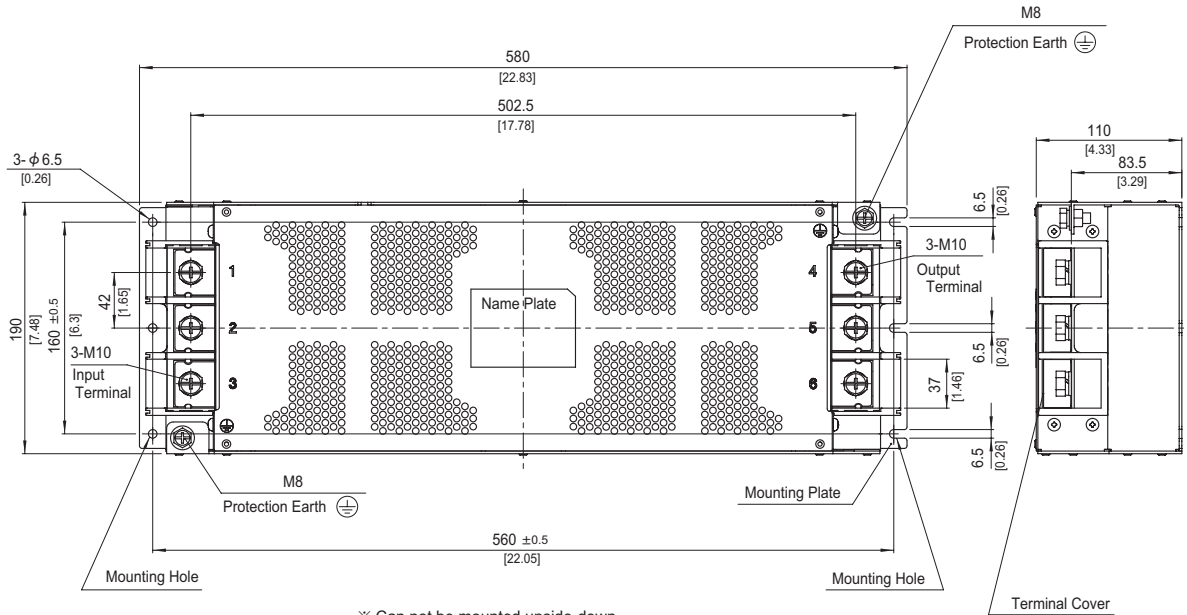

※ Can not be mounted upside-down.
(mounted the top surface)

- ※ Tolerance : ±1 [±0.04]
- ※ Weight : 13.0kg max
- ※ Mounting Plate : Stainless steel t=2.0 [0.08]
- ※ Dimensions in mm, []=inches
- ※ Terminal block screw tightening torque M10 : 14.2N · m (144.9kgf · cm) max
- ※ Protection Earth screw tightening torque M8 : 9.2N · m (93.9kgf · cm) max

FTB series(80,100,150A)

FTB -80 -663 -□

① ② ③ ④

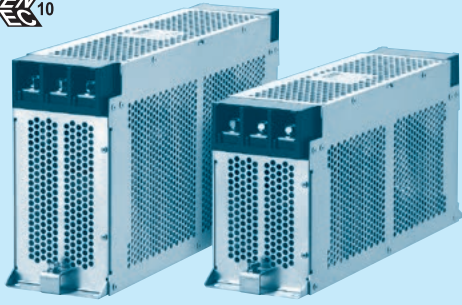
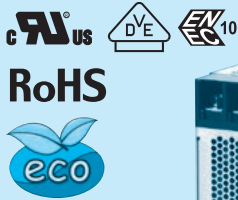

- ① Model Name
- ② Rated Current
- ③ Line to ground capacitor code: See table 1.1.

table 1.1 Line to ground capacitor code

Code	Leakage Current *2 Upper row : Δ-connection Lower row : Y-connection	Line to ground capacitor CY1 (nominal value)	Line to ground capacitor CY2 (nominal value)
203	1.0mA/2.0mA max 0.1mA/0.2mA max	10,000pF	10,000pF
663	2.5mA/5.0mA max 0.35mA/0.7mA max	33,000pF	33,000pF
324	12mA/24mA max 1.5mA/3.0mA max	220,000pF	100,000pF
355 *1	330mA/515mA max 40mA/80mA max	220,000pF	3,300,000pF

* When the line to ground capacitor code is different, the attenuation characteristic is different.

*1 "355" is applied only to "L" type.

*2 Input 250/500V 60Hz
(Only Δ-connection of "355" is 250/400V 60Hz)

- ④ Option
- H: Ultra high-attenuation type
"355" is not applied
- S: Hexagon socket head cap screw
(Standard type is Hexagon head screw)
- L: Ultra high-attenuation type for EU

Features of FTB series

Book type (Space-saving type)

- 2-stage filter High-attenuation (150kHz - 1MHz)
- Selectable leakage current value, Ultra high-attenuation type "-355-L" for EU (Y type with neutral earth system)

Specifications

No.	Items	FTB-80-663	FTB-100-663	FTB-150-663
1	Rated Voltage[V]	AC Three Phase 500 (voltage range: 528 max) 50/60Hz *3		
2	Rated Current[A]	80	100	150
3	Test Voltage (Terminal-Mounting Plate)	2,500 VAC (Cutoff Current = 100mA), 1minute at room temperature and humidity *4		
4	Isolation Resistance (Terminal-Mounting Plate)	500 VDC 100MΩ min at room temperature and humidity *5		
5	Leakage current 250/500V 60Hz	2.5mA/5.0mA max		
6	DC resistance	10mΩ max	8mΩ max	6mΩ max
7	Safety agency approval temperatures	-25 to +85°C (Refer to Derating Curve)		
8	Operating temperature	-40 to +85°C (Refer to Derating Curve)		
9	Operating humidity	20 to 95%RH (Non condensing)		
10	Storage temperature/humidity	-40 to +85°C/20 to 95%RH (Non condensing)		
11	Vibration	10 to 55Hz, 19.6m/s ² (2G), 3min. Period, 1hour each X, Y and Z axis		
12	Impact	196.1m/s ² (20G), 11ms Once each X, Y and Z axis		
13	Safety agency approvals	UL1283, CSA C22.2 No.8 (C-UL), DIN EN60939 VDE0565 Teil3-1, ENEC		
14	Case size (without projection)	100 X 170 X 350 mm (W X H X D)		100 X 210 X 400 mm (W X H X D)
		[3.94 X 6.69 X 13.78 inches]		[3.94 X 8.27 X 15.75 inches]
15	Weight	5.3kg max		7.8kg max

*3 Only capacitor code "355", Three Phase Δ-connection : 400 (440 max), Y-connection : 500 (528 max)

*4 Only capacitor code "324","355" 2,800 VDC (Cutoff Current = 10mA), 1minute at room temperature and humidity.

*5 Only capacitor code "355", Isolation resistance specification is deleted.

Circuit Diagram

(1) Line to ground capacitor code : 203, 663, 324

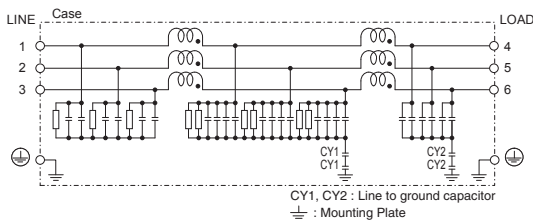

(2) FTB-□□-355-L

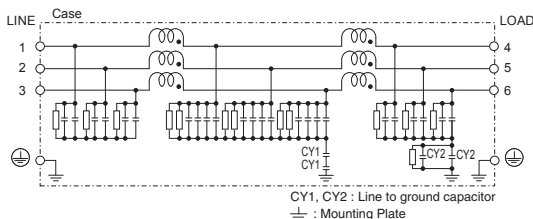

Derating Curve

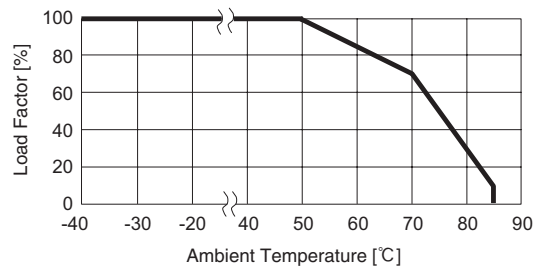

* Keep free ventilation holes for cooling.

External view

FTB-80-□□□ / FTB-100-□□□

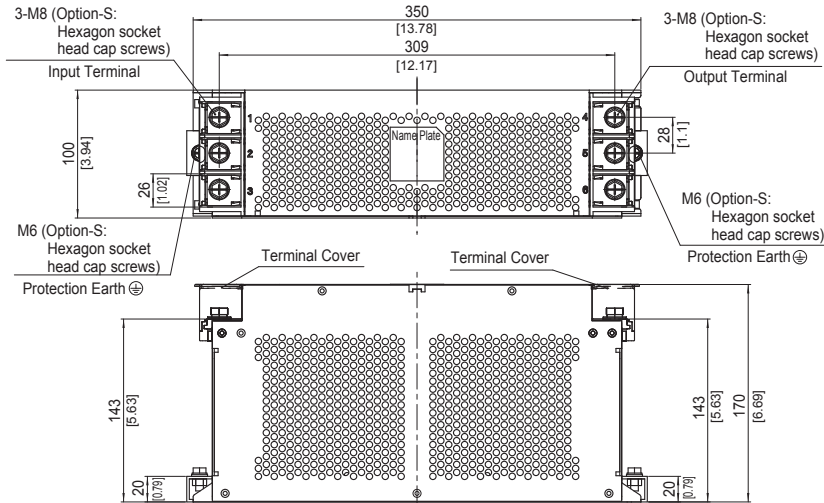

※ The air hole for heat radiation is not on the opposite side side.

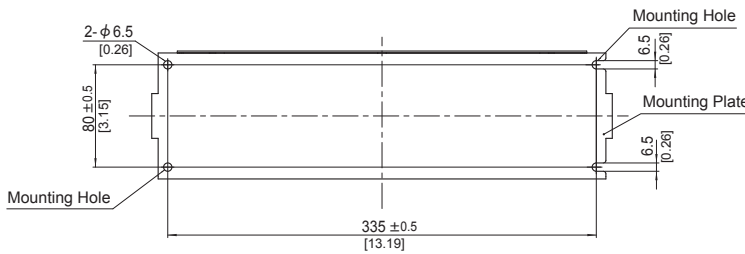

- ※ Tolerance : ± 1 [± 0.04]
- ※ Weight : 5.3kg max
- ※ Mounting Plate : Aluminum $t=2.0$ [0.08]
- ※ Dimensions in mm, []=inches
- ※ Terminal block screw tightening torque
M8 : $9.2N \cdot m$ (93.9kgf · cm)max
- ※ Protection Earth (PE) screw tightening torque
M6 : $5.8N \cdot m$ (59.2kgf · cm)max
- ※ Can not be mounted upside-down (mounted the top surface)
- ※ Keep free ventilation holes for cooling

FTB-150-□□□

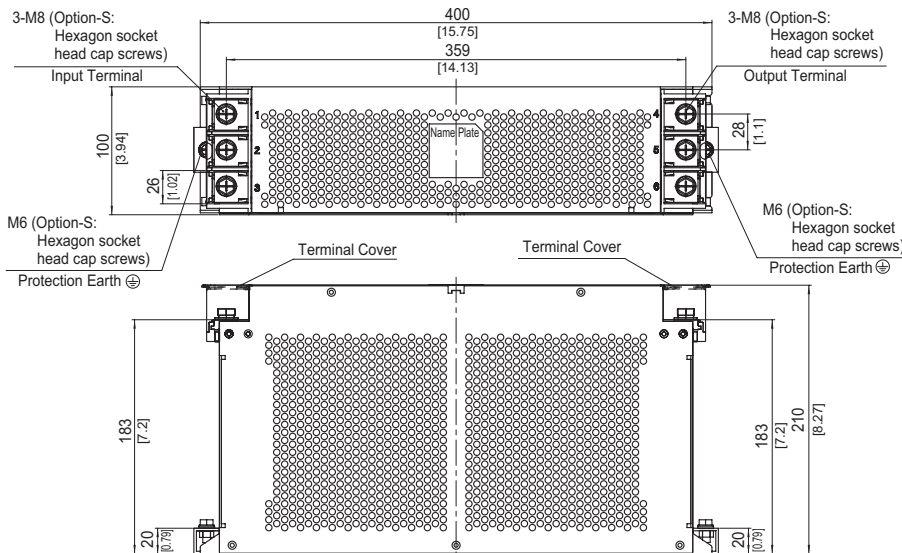

※ The air hole for heat radiation is not on the opposite side side.

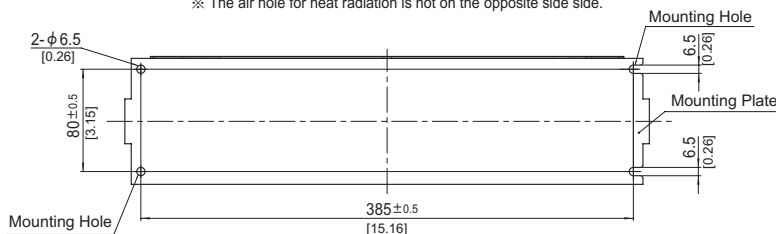

- ※ Tolerance : ± 1 [± 0.04]
- ※ Weight : 7.8kg max
- ※ Mounting Plate : Aluminum $t=2.0$ [0.08]
- ※ Dimensions in mm, []=inches
- ※ Terminal block screw tightening torque
M8 : $9.2N \cdot m$ (93.9kgf · cm)max
- ※ Protection Earth (PE) screw tightening torque
M6 : $5.8N \cdot m$ (59.2kgf · cm)max
- ※ Can not be mounted upside-down (mounted the top surface)
- ※ Keep free ventilation holes for cooling

FTB-80-203

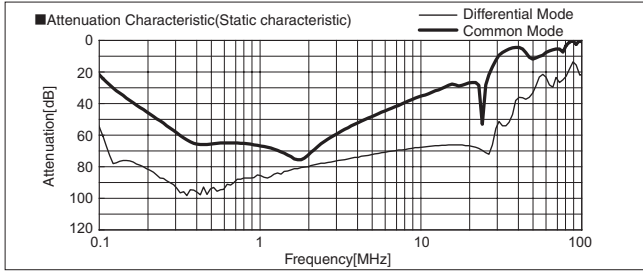

FTB-80-663

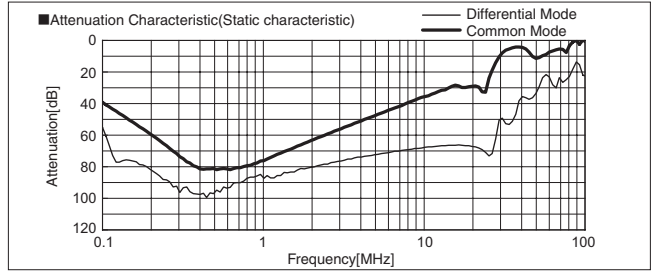

FTB-80-324

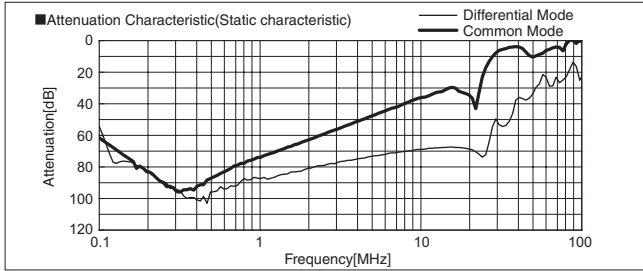

FTB-100-203

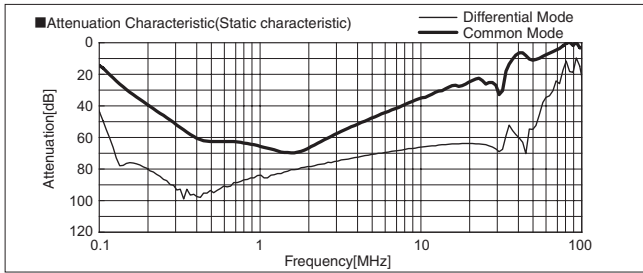

FTB-100-663

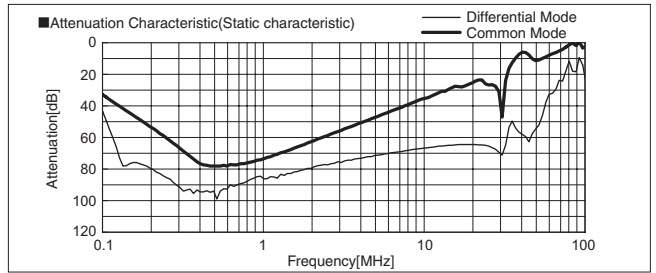

FTB-100-324

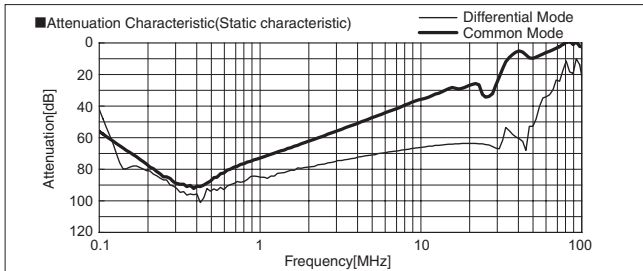

FTB-150-203

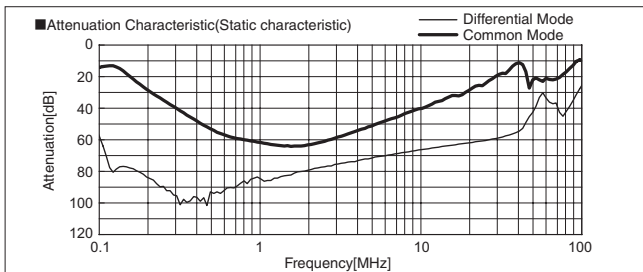

FTB-150-663

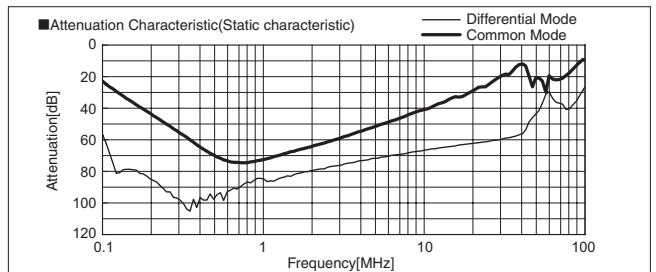

FTB-150-324

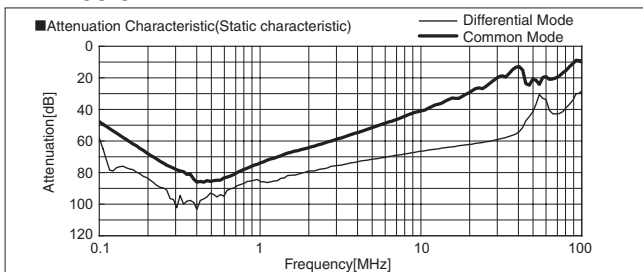

FTB-80-203-H

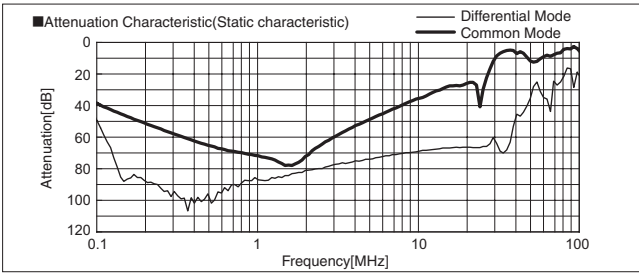

FTB-80-663-H

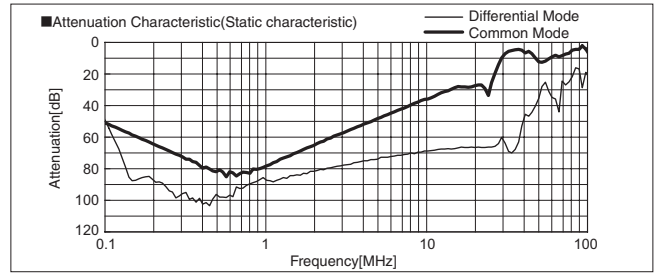

FTB-80-324-H

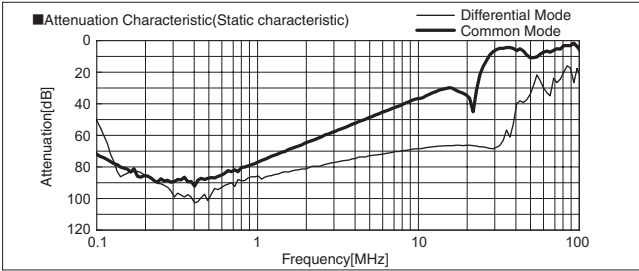

FTB-100-203-H

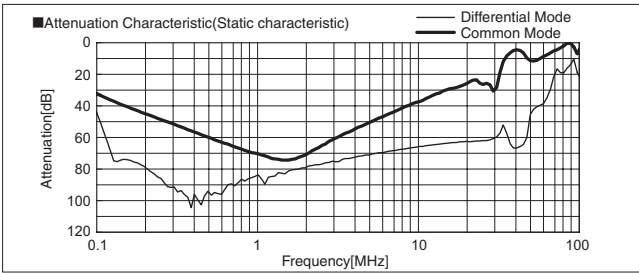

FTB-100-663-H

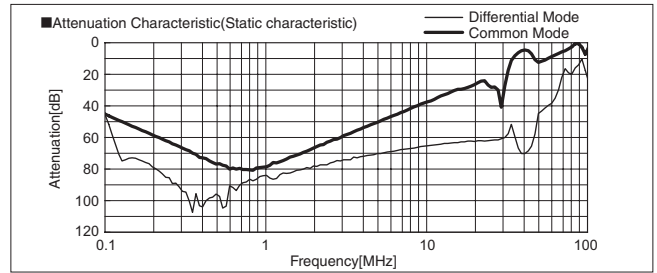

FTB-100-324-H

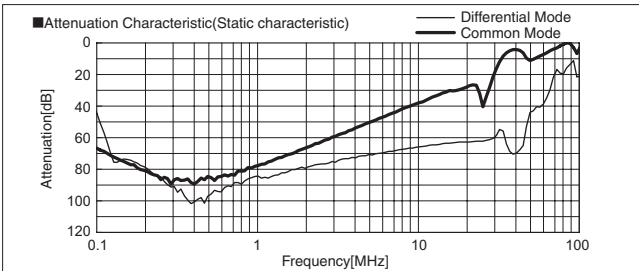

FTB-150-203-H

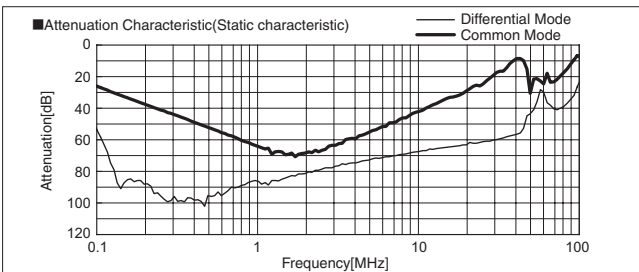

FTB-150-663-H

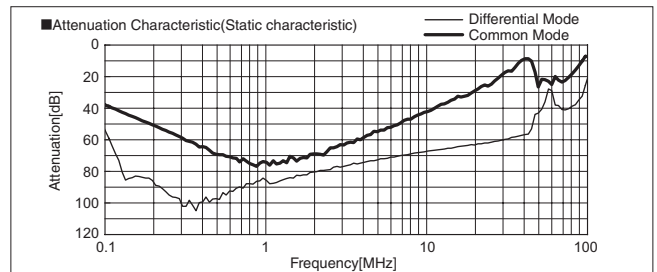

FTB-150-324-H

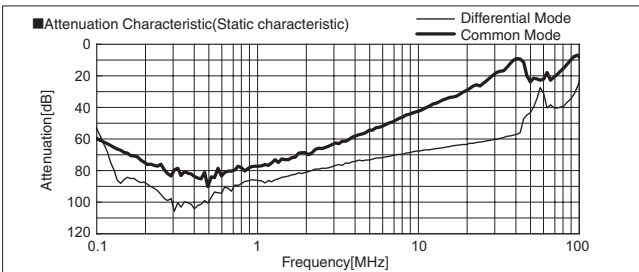

FSB series(10,20,30A)

FSB -30 -324 -□

① ② ③ ④



The terminal cover is retracted inside the unit

Features of FSB series

EMI/EMC Filter for motor drive system (AC servo)

- Improve saturation resistance (There is such as performance improvement type “-254-HU”)
- Book type (Space-saving type)
- Quick and easy push-down terminal
Just connect the wires, push-down and tighten the screws with a screwdriver

Specifications

No.	Items	FSB-10-324	FSB-20-324	FSB-30-324
1	Rated Voltage[V]	AC Three Phase 500 (voltage range:528 max) 50/60Hz *3 *4		
2	Rated Current[A]	10	20	30
3	Test Voltage (Terminal-Mounting Plate)	2,800 VDC (Cutoff Current = 10mA), 1minute at room temperature and humidity *5		
4	Isolation Resistance (Terminal-Mounting Plate)	500 VDC 100MΩ min at room temperature and humidity *6		
5	Leakage current 250/500V 60Hz	12mA/24mA max		
6	DC resistance	100mΩ max	38mΩ max	20mΩ max
7	Safety agency approval temperatures	-25 to +85°C (Refer to Derating Curve)		
8	Operating temperature	-40 to +85°C (Refer to Derating Curve)		
9	Operating humidity	20 to 95%RH (Non condensing)		
10	Storage temperature/humidity	-40 to +85°C/20 to 95%RH (Non condensing)		
11	Vibration	10 to 55Hz, 19.6m/s ² (2G), 3min. Period, 1hour each X, Y and Z axis		
12	Impact	196.1m/s ² (20G), 11ms Once each X, Y and Z axis		
13	Safety agency approvals	UL1283, CSA C22.2 No.8 (C-UL), DIN EN60939 VDE0565 Teil 3-1, ENEC		
14	Case size (without projection)	66 X 100 X 240 mm (W X H X D) [2.60 X 3.94 X 9.45 inches] (W X H X D)		
15	Weight	1.8kg max		

*3 Only capacitor code “355”, Three Phase Δ-connection : 400 (440 max), Y-connection : 500 (528 max)
 *4 Only “FSB-□□□□□□□□-U”, Three Phase 250 (275 max)
 *5 Only capacitor code “203”, “573”, “693”, “104”, 2,500VAC (Cutoff Current = 100mA), 1minute at room temperature and humidity.
 *6 Only capacitor code “335”, “355”, Isolation resistance specification is deleted.

- ① Model Name
- ② Rated Current
- ③ Line to ground capacitor code: See table 1.1.

table1.1 Line to ground capacitor code

Code	Leakage Current *1 Upper row : Δ-connection Lower row : Y-connection	Line to ground capacitor CY1 (nominal value)	Line to ground capacitor CY2 (nominal value)
203	1.0mA/2.0mA max 0.1mA/0.2mA max	0.01μF	0.01μF
573 *2	2.5mA max/Not applicable 0.35mA max/Not applicable	0.01μF	0.047μF
693	2.5mA/5.0mA max 0.35mA/0.7mA max	0.022μF	0.047μF
104	3.5mA/7.0mA max 0.5mA/1.0mA max	0.033μF	0.068μF
254 *2	12mA max/Not applicable 1.5mA max/Not applicable	0.033μF	0.22μF
324	12mA/24mA max 1.5mA/3.0mA max	0.1μF	0.22μF
335 *2	160mA max/Not applicable 20mA max/Not applicable	0.033μF	3.3μF
355	180mA/270mA max 25mA/50mA max	0.22μF	3.3μF

- * When the line to ground capacitor code is different, the attenuation characteristic is different.
- *1 Input 250/500V 60Hz (Only Δ-connection of “355” is 250/400V 60Hz)
- *2 Only “U” type is applied.
- ④ Option
 H : Ultra high-attenuation type
 U : Improve differential mode attenuation (Rated voltage 250V)
 Only “573”, “254”, “335” is applied.

Circuit Diagram

(1) Line to ground capacitor code : 203, 693, 104, 324

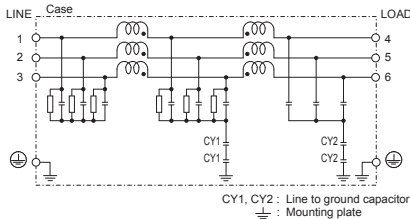

(2) Line to ground capacitor code : 355

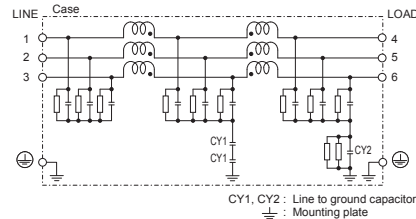

(3) Line to ground capacitor code : 573, 254
Option : U

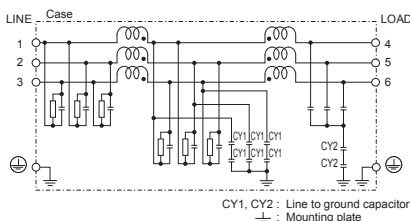

(4) Line to ground capacitor code : 335
Option : U

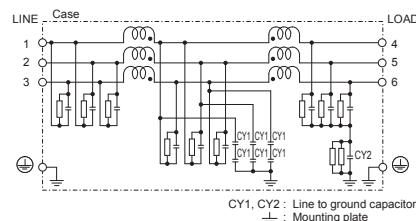

Derating Curve

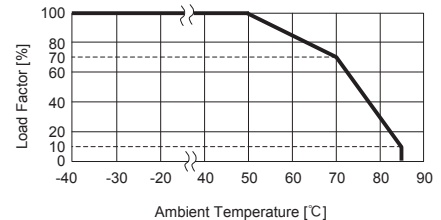

* Keep free ventilation holes for cooling.

External view

This product is shipped in the following condition, because it is equipped with push-down terminals.

- ① The terminal cover is retracted inside the unit.
- ② The screws for connecting the terminals are held in the up right position.

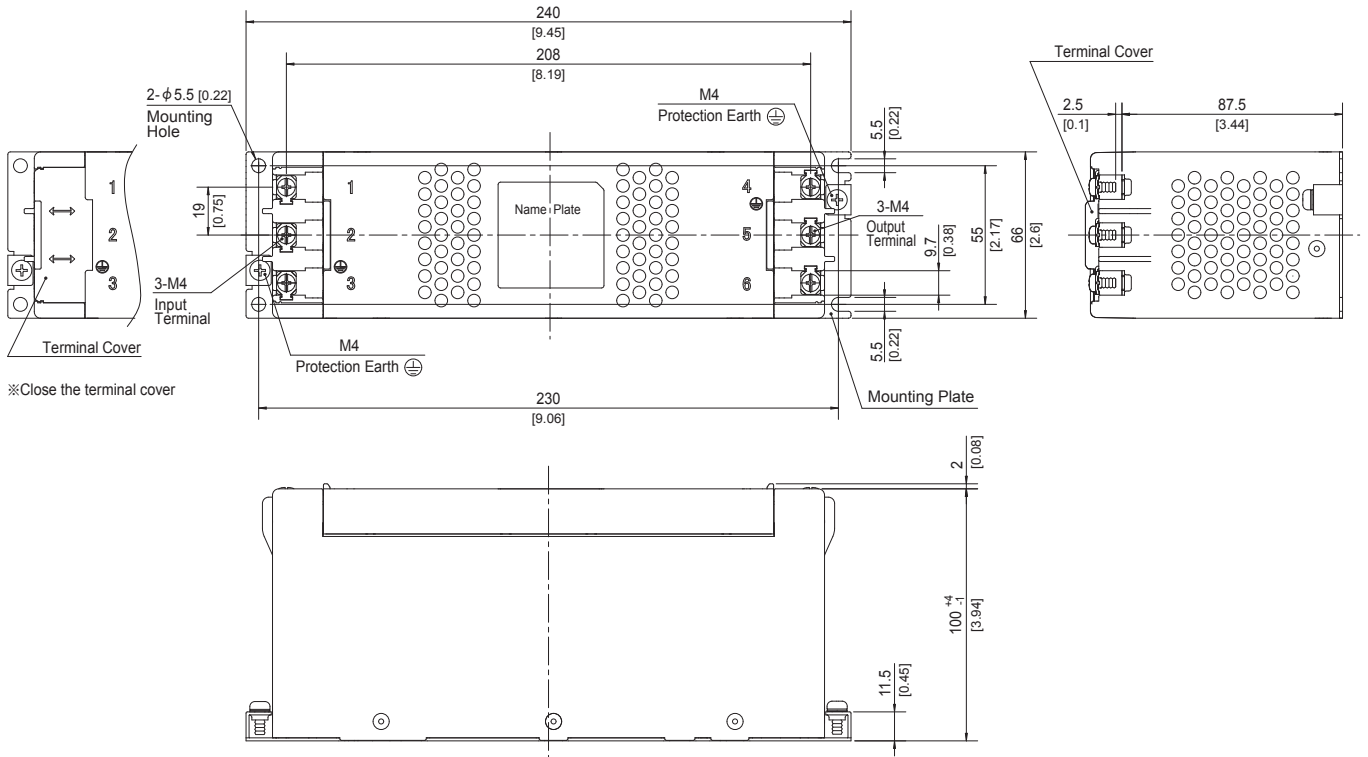

※Close the terminal cover

- ※ Tolerance : ± 1 [± 0.04]
- ※ Weight : 1.8kg max
- ※ Mounting Plate : Hot-dip Galvanized Steel board $t=1.2$ [0.05]
- ※ Case : PBT
- ※ Dimensions in mm, []=inches
- ※ Terminal block screw tightening torque M4 : $1.6N \cdot m$ (16.9kgf·cm)max
- ※ Can not be mounted upside-down (mounted the top surface)
- ※ Keep free ventilation holes for cooling

FSB-10-693-H

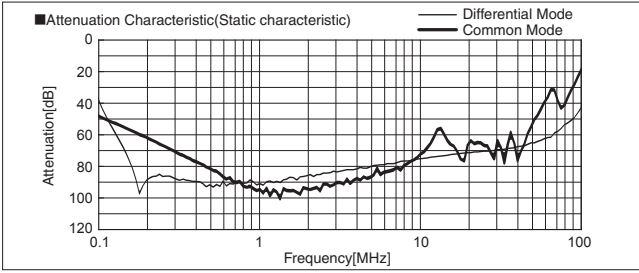

FSB-10-104-H

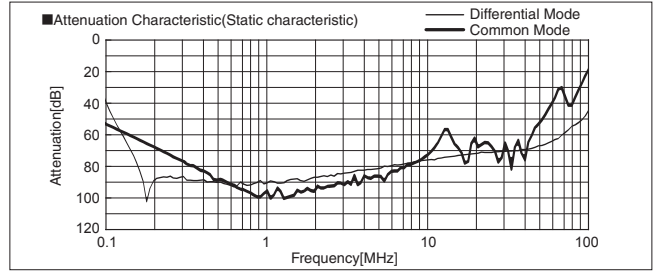

FSB-10-324-H

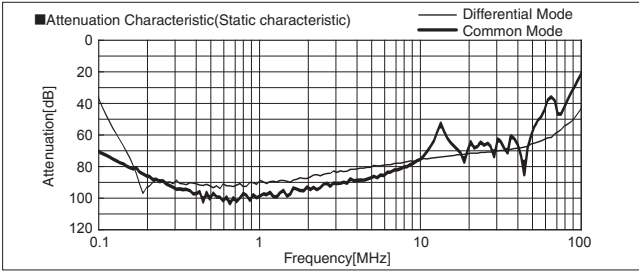

FSB-10-355-H

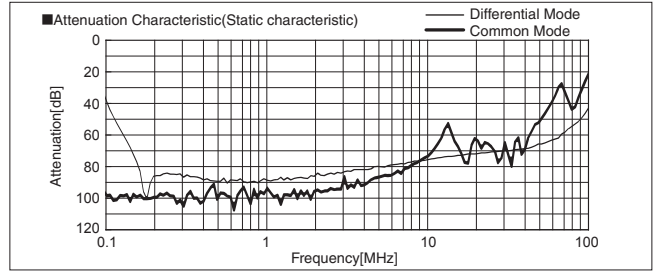

FSB-20-693-H

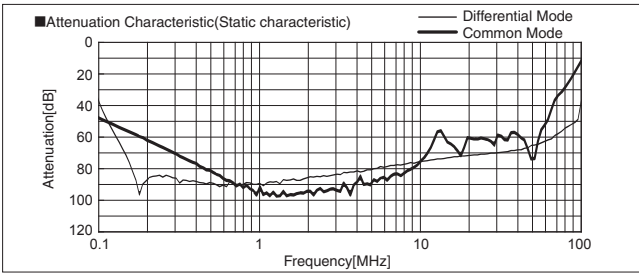

FSB-20-104-H

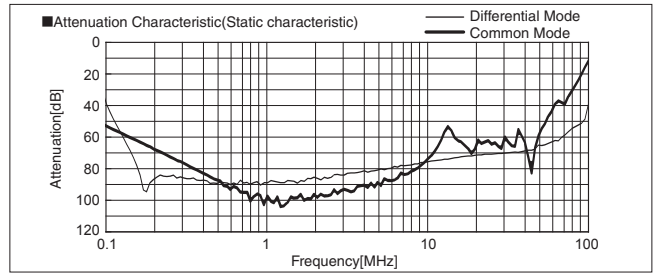

FSB-20-324-H

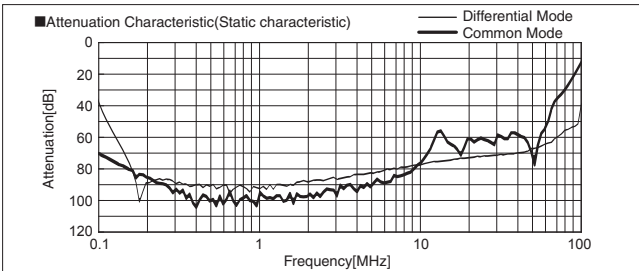

FSB-20-355-H

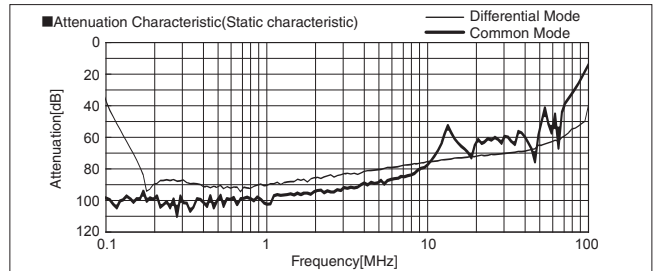

FSB-30-693-H

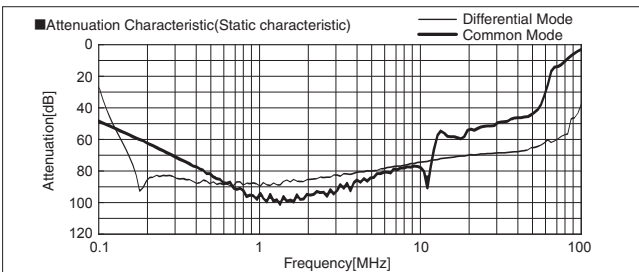

FSB-30-104-H

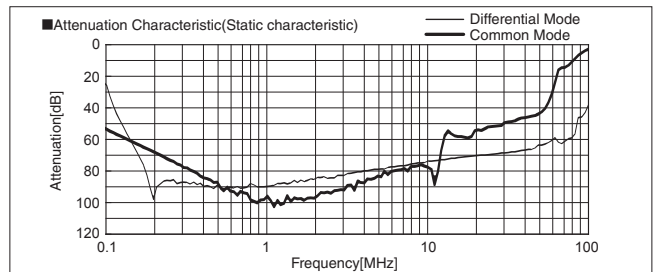

FSB-30-324-H

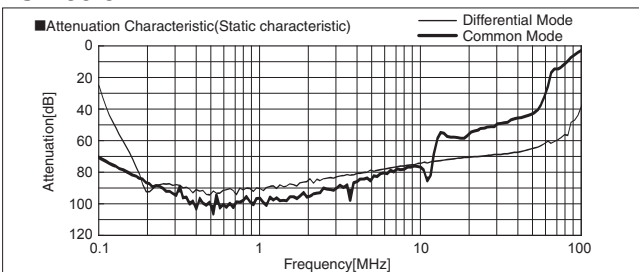

FSB-30-355-H

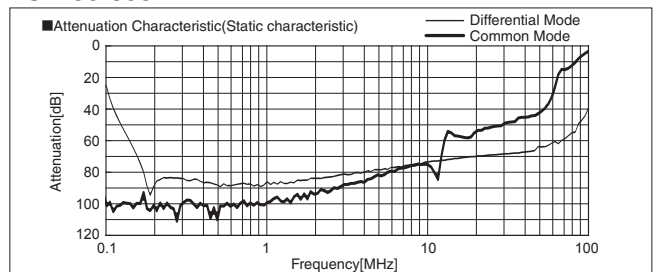

FSB-10-573-U

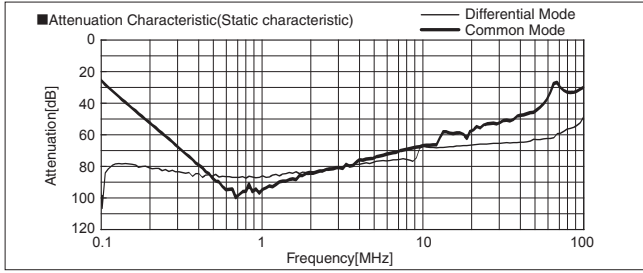

FSB-10-254-U

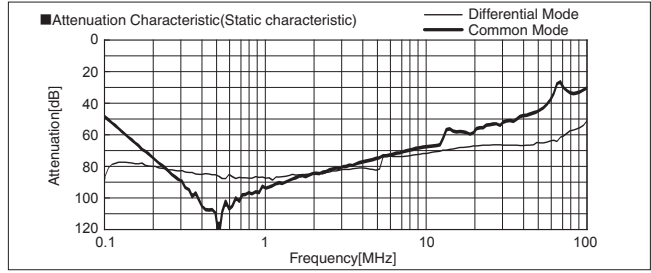

FSB-10-335-U

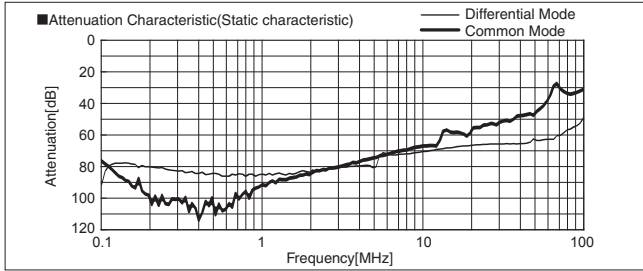

FSB-20-573-U

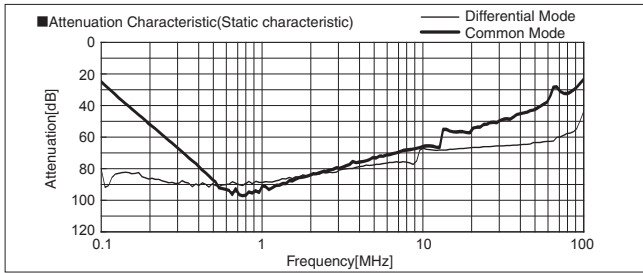

FSB-20-254-U

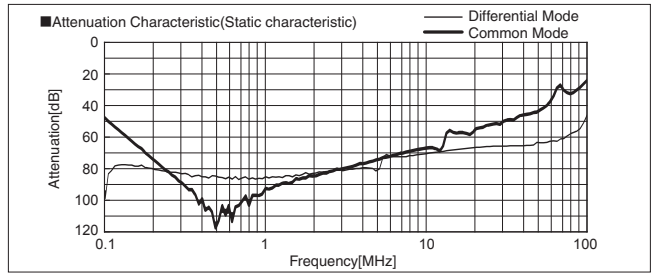

FSB-20-335-U

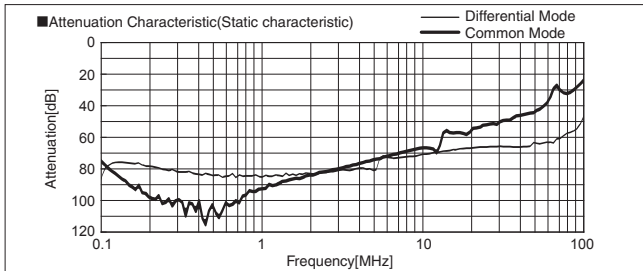

FSB-30-573-U

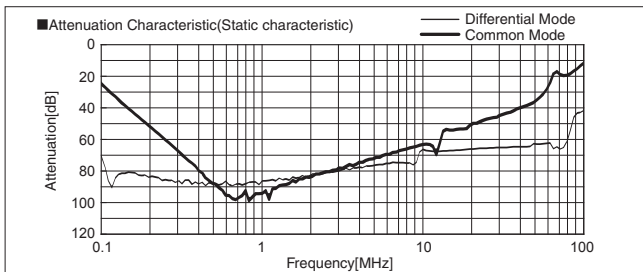

FSB-30-254-U

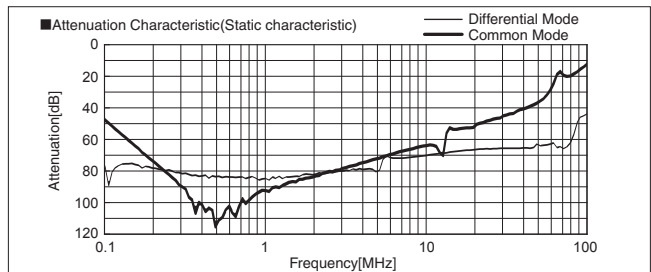

FSB-30-335-U

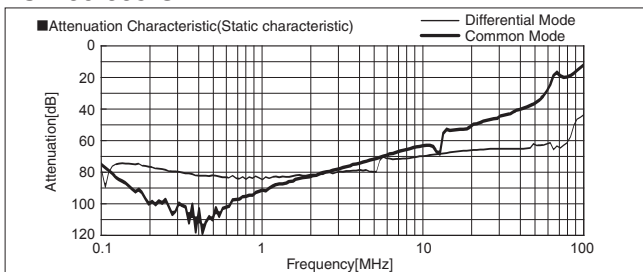

FSB series(40,50,60A)

FSB -60 -324 -□

① ② ③ ④



- ① Model Name
- ② Rated Current
- ③ Line to ground capacitor code: See table 1.1.

table 1.1 Line to ground capacitor code

Code	Leakage Current *1 Upper row : Δ-connection Lower row : Y-connection	Line to ground capacitor CY1 (nominal value)	Line to ground capacitor CY2 (nominal value)
203	1.0mA/2.0mA max 0.1mA/0.2mA max	0.01 μF	0.01 μF
693	2.5mA/5.0mA max 0.35mA/0.7mA max	0.022 μF	0.047 μF
104	3.5mA/7.0mA max 0.5mA/1.0mA max	0.033 μF	0.068 μF
324	12mA/24mA max 1.5mA/3.0mA max	0.1 μF	0.22 μF
355	180mA/270mA max 25mA/50mA max	0.22 μF	3.3 μF

* When the line to ground capacitor code is different, the attenuation characteristic is different.

*1 Input 250/500V 60Hz (Only Δ-connection of "355" is 250/400V 60Hz)

- ④ Option
- H : Ultra high-attenuation type
"355" is not applied.
- U : Improve differential mode attenuation
(Rated voltage 250V)

Features of FSB series

EMI/EMC Filter for motor drive system (AC servo)

- Improve saturation resistance (There is such as performance improvement type "-324-HU")
- Book type (Space-saving type)

Specifications

No.	Items	FSB-40-324	FSB-50-324	FSB-60-324
1	Rated Voltage[V]	AC Three Phase 500 (voltage range: 528 max) 50/60Hz *2 *3		
2	Rated Current[A]	40	50	60
3	Test Voltage (Terminal-Mounting Plate)	2,800 VDC (Cutoff Current = 10mA), 1minute at room temperature and humidity *4		
4	Isolation Resistance (Terminal-Mounting Plate)	500 VDC 100MΩ min at room temperature and humidity *5		
5	Leakage current 250/500V 60Hz	12mA/24mA max		
6	DC resistance	17mΩ max	14mΩ max	10mΩ max
7	Safety agency approval temperatures	-25 to +85°C (Refer to Derating Curve)		
8	Operating temperature	-40 to +85°C (Refer to Derating Curve)		
9	Operating humidity	20 to 95%RH (Non condensing)		
10	Storage temperature/humidity	-40 to +85°C/20 to 95%RH (Non condensing)		
11	Vibration	10 to 55Hz, 19.6m/s ² (2G), 3min. Period, 1hour each X, Y and Z axis		
12	Impact	196.1m/s ² (20G), 11ms Once each X, Y and Z axis		
13	Safety agency approvals	UL1283, CSA C22.2 No.8 (C-UL), DIN EN60939 VDE0565 Teil 3-1, ENEC		
14	Case size (without projection)	90 X 125 X 290 mm (W X H X D) [3.54 X 4.92 X 11.42 inches] (W X H X D)		
15	Weight	3.3kg max		

*2 Only capacitor code "355", Three Phase Δ-connection : 400 (440 max), Y-connection : 500 (528 max)

*3 Only "FSB-□□□□□□-U", Three Phase 250 (275 max)

*4 Only capacitor code "203", "693", "104", 2,500VAC (Cutoff Current = 100mA), 1minute at room temperature and humidity.

*5 Only capacitor code "355", Isolation resistance specification is deleted.

Circuit Diagram

(1) Line to ground capacitor code : 203, 693, 104, 324

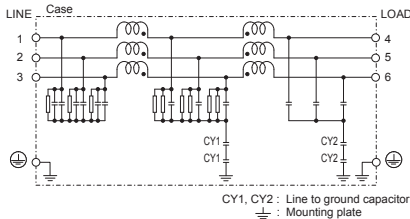

(2) Line to ground capacitor code : 355

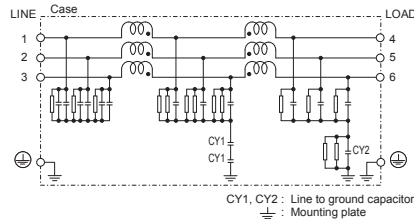

(3) Line to ground capacitor code : 203, 693, 104, 324
Option : U

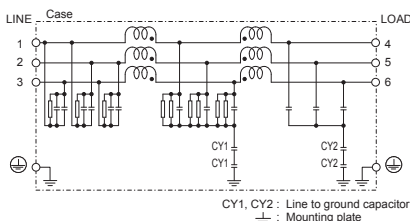

(4) Line to ground capacitor code : 355
Option : U

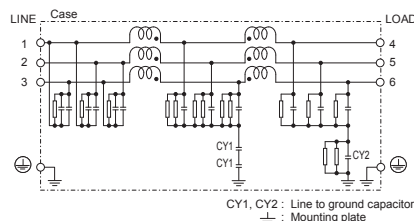

Derating Curve

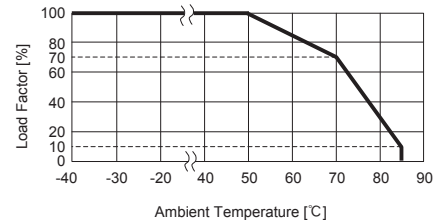

* Keep free ventilation holes for cooling.

External view

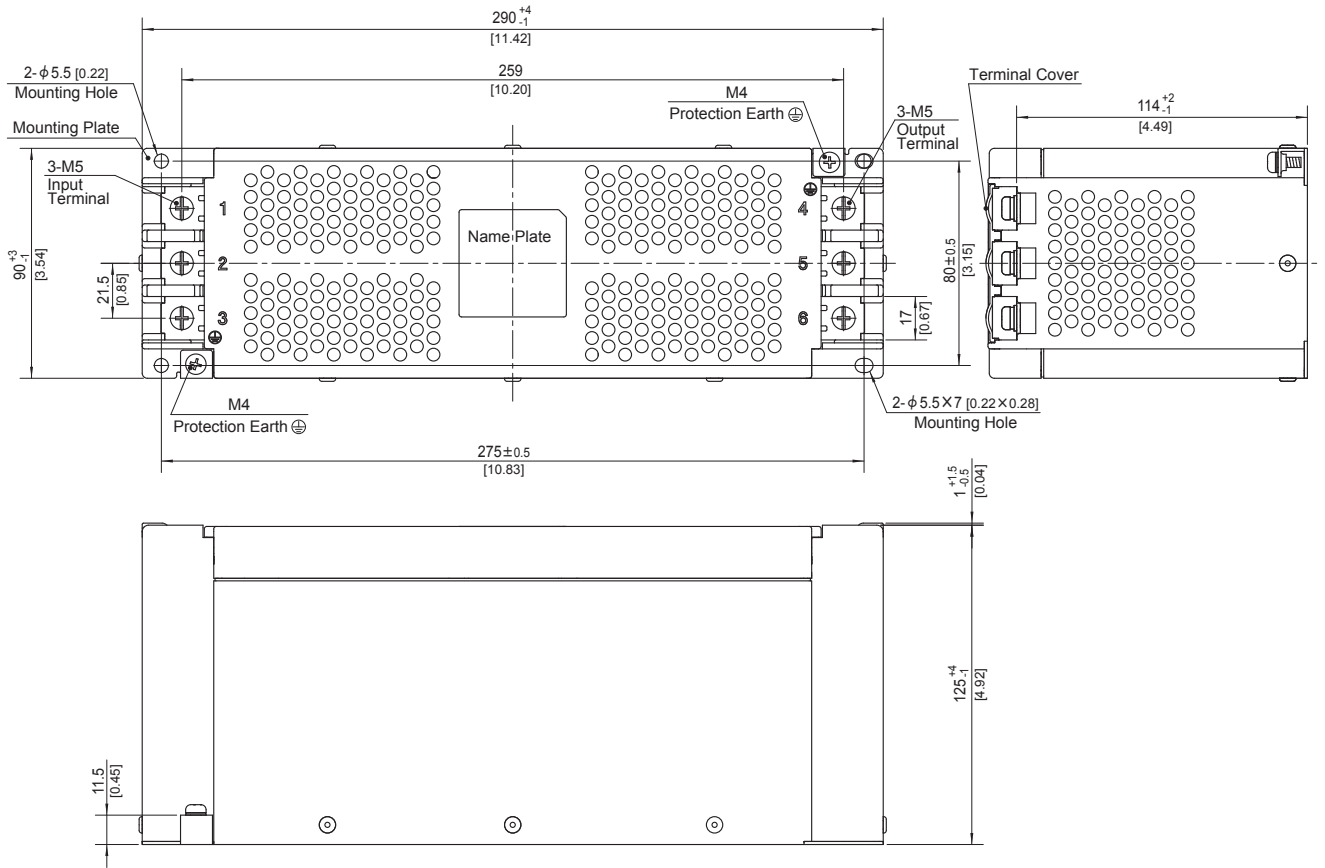

- ※ Tolerance : ± 1 [± 0.04]
- ※ Weight : 3.3kg max
- ※ Mounting Plate : Hot-dip Galvanized Steel board t=1.2 [0.05]
- ※ Case Material : PBT
- ※ Dimensions in mm, []=inches
- ※ Terminal block screw tightening torque M5 : 3.0N · m(30.7kgf · cm)max
- ※ Protection Earth(PE) screw tightening torque M4 : 1.6N · m(16.9kgf · cm)max
- ※ Can not be mounted upside-down(mounted the top surface)
- ※ Keep free ventilation holes for cooling

FSB-40-693-H

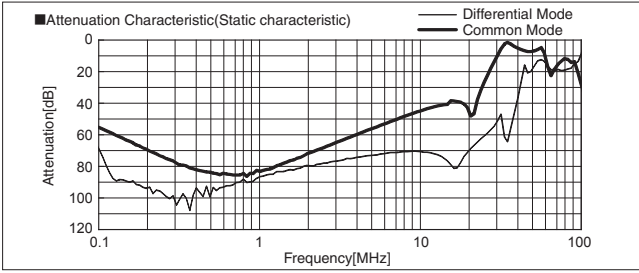

FSB-40-104-H

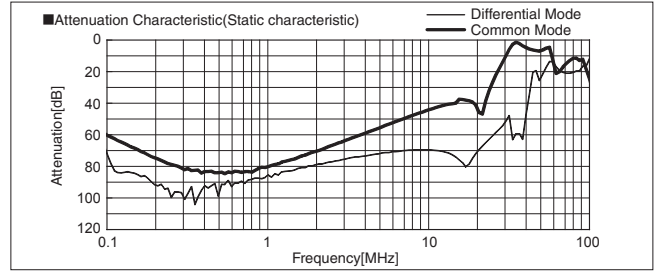

FSB-40-324-H

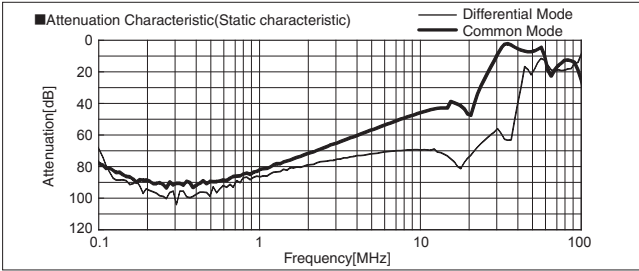

FSB-50-693-H

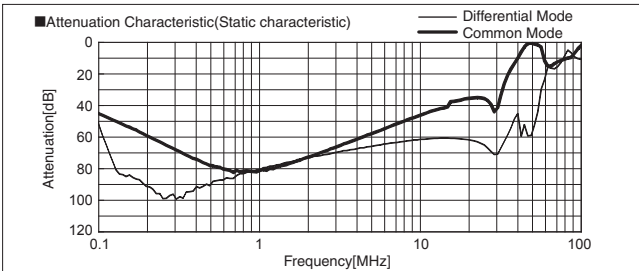

FSB-50-104-H

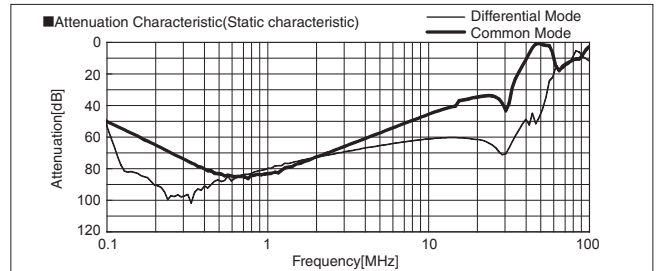

FSB-50-324-H

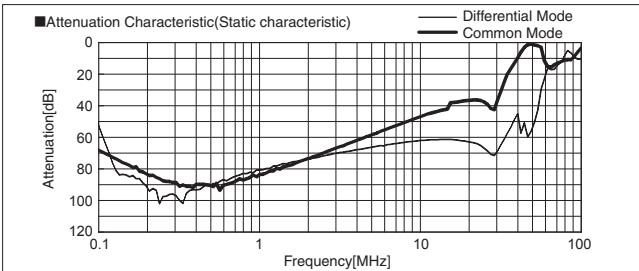

FSB-60-693-H

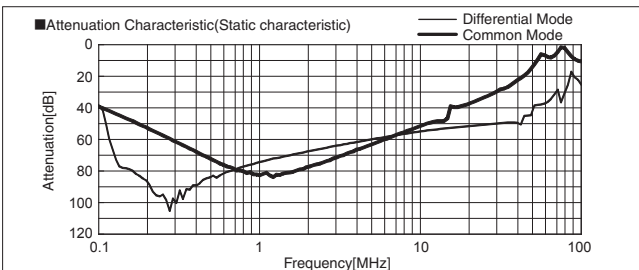

FSB-60-104-H

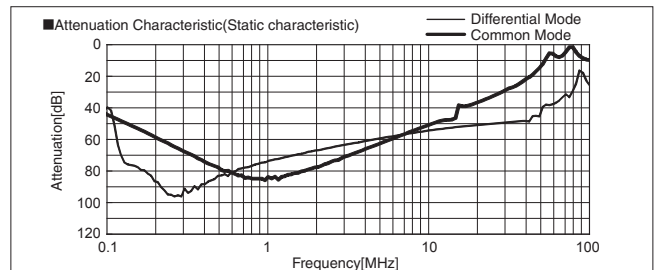

FSB-60-324-H

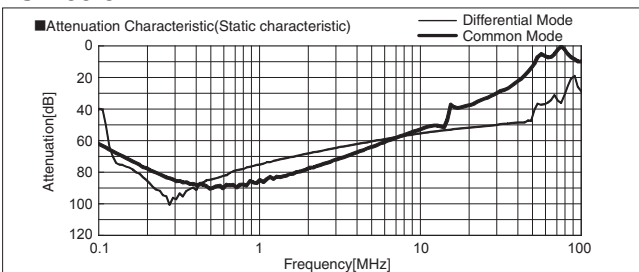

FSB-40-693-U

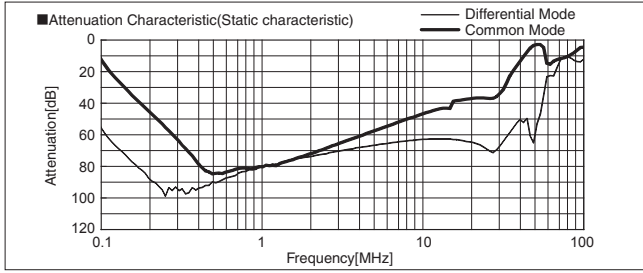

FSB-40-104-U

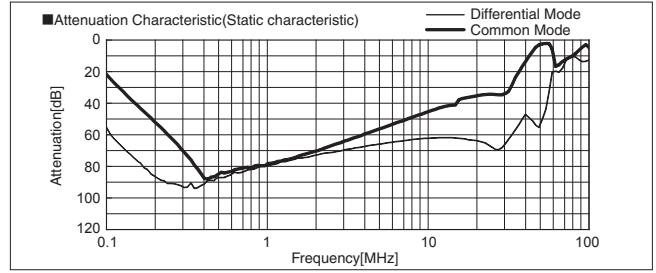

FSB-40-324-U

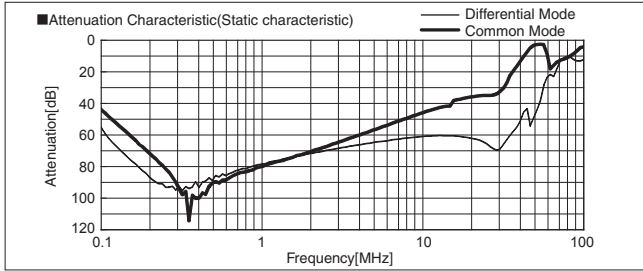

FSB-40-355-U

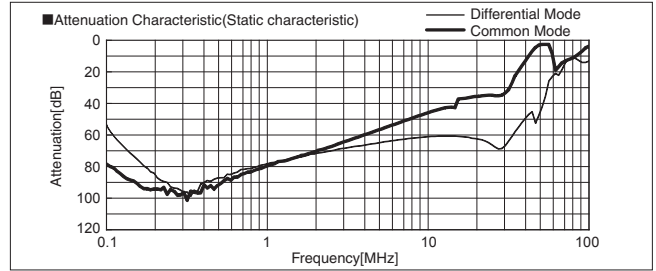

FSB-50-693-U

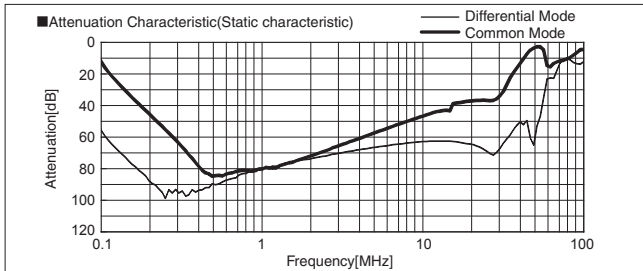

FSB-50-104-U

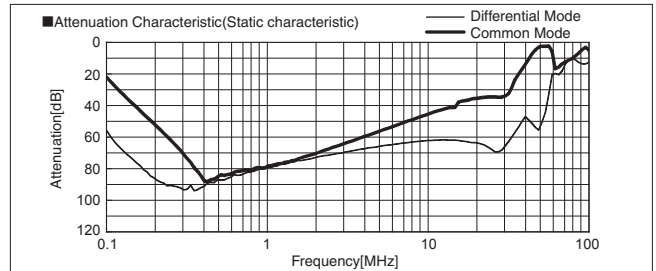

FSB-50-324-U

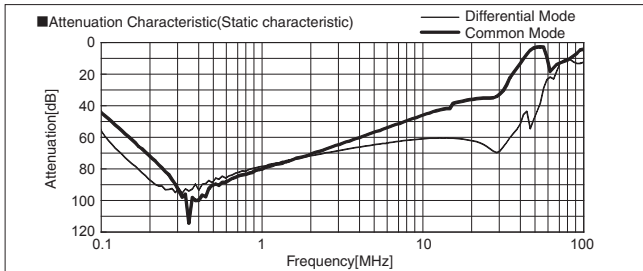

FSB-50-355-U

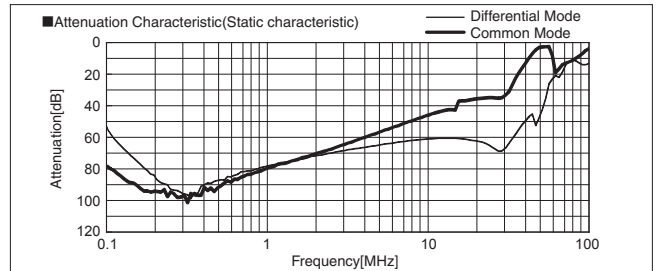

FSB-60-693-U

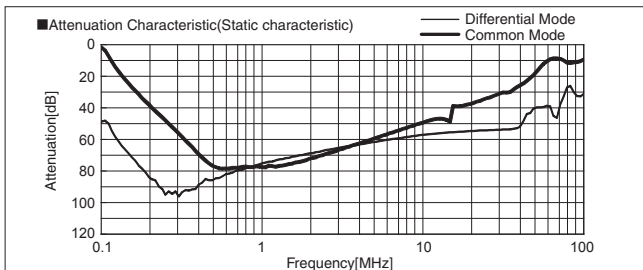

FSB-60-104-U

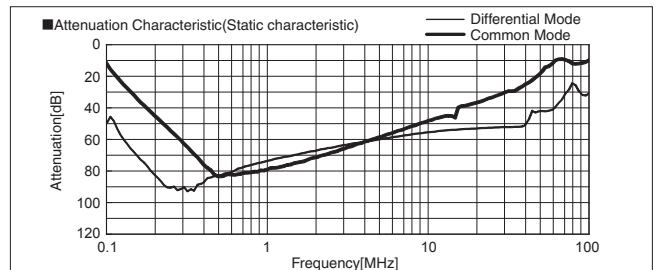

FSB-60-324-U

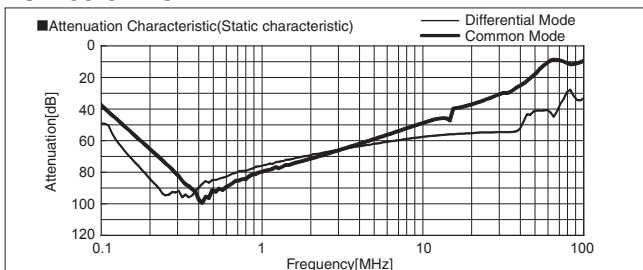

FSB-60-355-U

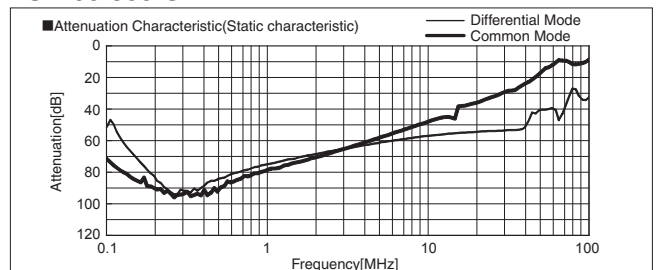

FSB series(80,100,150A)

FSB -150 -324 -□

① ② ③ ④

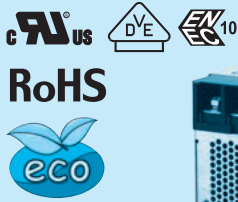

Features of FSB series

EMI/EMC Filter for motor drive system (AC servo)

- Improve saturation resistance (There is such as performance improvement type “-324-HU”)
- Book type (Space-saving type)

- ① Model Name
- ② Rated Current
- ③ Line to ground capacitor code: See table 1.1.

table 1.1 Line to ground capacitor code

Code	Leakage Current *1 Upper row : Δ-connection Lower row : Y-connection	Line to ground capacitor CY1 (nominal value)	Line to ground capacitor CY2 (nominal value)
203	1.0mA/2.0mA max 0.1mA/0.2mA max	0.01 μF	0.01 μF
693	2.5mA/5.0mA max 0.35mA/0.7mA max	0.022 μF	0.047 μF
104	3.5mA/7.0mA max 0.5mA/1.0mA max	0.033 μF	0.068 μF
324	12mA/24mA max 1.5mA/3.0mA max	0.1 μF	0.22 μF
355	330mA/515mA max 40mA/80mA max	0.22 μF	3.3 μF

* When the line to ground capacitor code is different, the attenuation characteristic is different.

*1 Input 250/500V 60Hz (Only Δ-connection of “355” is 250/400V 60Hz)

- ④ Option
- H : Ultra high-attenuation type
“355” is not applied.
- S : Hexagon socket head cap screw
(Standard type is Hexagon head screw)
- U : Improve differential mode attenuation
(Rated voltage 250V)

Specifications

No.	Items	FSB-80-324	FSB-100-324	FSB-150-324
1	Rated Voltage[V]	AC Three Phase 500 (voltage range:528 max) 50/60Hz *2 *3		
2	Rated Current[A]	80	100	150
3	Test Voltage (Terminal-Mounting Plate)	2,800 VDC (Cutoff Current = 10mA), 1minute at room temperature and humidity *4		
4	Isolation Resistance (Terminal-Mounting Plate)	500 VDC 100MΩ min at room temperature and humidity *5		
5	Leakage current 250/500V 60Hz	12mA/24mA max		
6	DC resistance	10mΩ max	8mΩ max	6mΩ max
7	Safety agency approval temperatures	-25 to +85°C (Refer to Derating Curve)		
8	Operating temperature	-40 to +85°C (Refer to Derating Curve)		
9	Operating humidity	20 to 95%RH (Non condensing)		
10	Storage temperature/humidity	-40 to +85°C/20 to 95%RH (Non condensing)		
11	Vibration	10 to 55Hz, 19.6m/s ² (2G), 3min. Period, 1hour each X, Y and Z axis		
12	Impact	196.1m/s ² (20G), 11ms Once each X, Y and Z axis		
13	Safety agency approvals	UL1283, CSA C22.2 No.8 (C-UL), DIN EN60939 VDE0565 Teil 3-1, ENEC		
14	Case size (without projection)	100 X 170 X 350 mm (W X H X D)		100 X 210 X 400 mm (W X H X D)
				[3.94 X 8.27 X 15.75 inches] (W X H X D)
15	Weight	6.3kg max		

*2 Only capacitor code “355”, Three Phase Δ-connection : 400 (440 max), Y-connection : 500 (528 max)

*3 Only “FSB-□□□□□□□□-U”, Three Phase 250 (275 max)

*4 Only capacitor code “203”, “693”, “104”, 2,500VAC (Cutoff Current = 100mA), 1minute at room temperature and humidity.

*5 Only capacitor code “355”, Isolation resistance specification is deleted.

Circuit Diagram

(1) Line to ground capacitor code : 203, 693, 104, 324

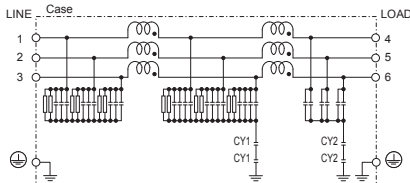

CY1, CY2 : Line to ground capacitor
⏏ : Mounting plate

(2) Line to ground capacitor code : 355

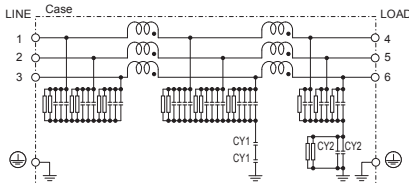

CY1, CY2 : Line to ground capacitor
⏏ : Mounting plate

(3) Line to ground capacitor code : 203, 693, 104, 324
Option : U

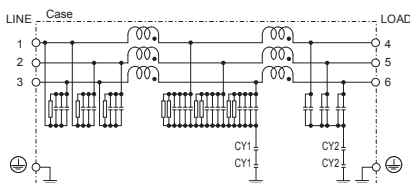

CY1, CY2 : Line to ground capacitor
⏏ : Mounting plate

(4) Line to ground capacitor code : 355
Option : U

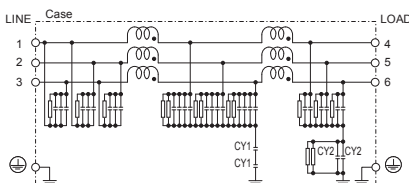

CY1, CY2 : Line to ground capacitor
⏏ : Mounting plate

Derating Curve

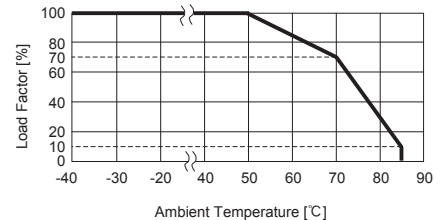

* Keep free ventilation holes for cooling.

External view

FSB-80 / FSB-100

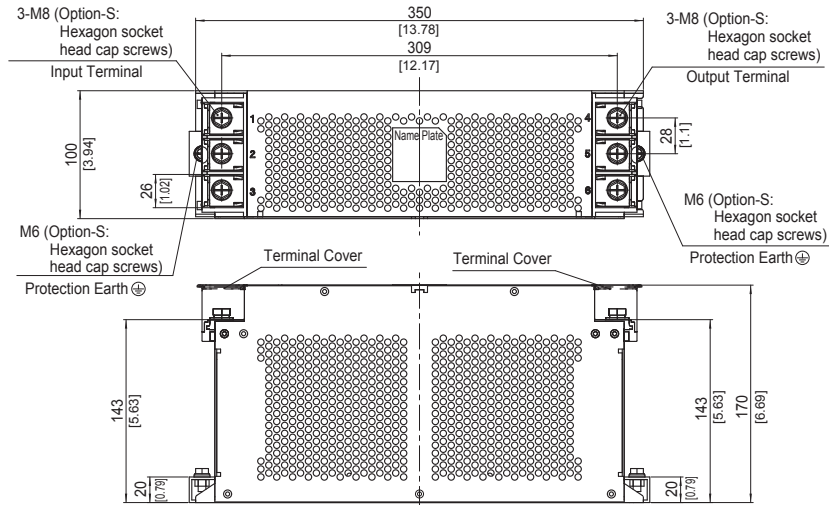

※ The air hole for heat radiation is not on the opposite side side.

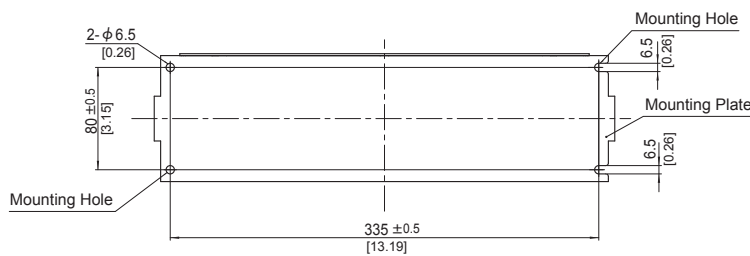

- ※ Tolerance : ± 1 [± 0.04]
- ※ Weight : 6.3kg max
- ※ Mounting Plate : Aluminum $t=2.0$ [0.08]
- ※ Dimensions in mm, []=inches
- ※ Terminal block screw tightening torque
M8 : $9.2N \cdot m$ (93.9kgf · cm)max
- ※ Protection Earth (PE) screw tightening torque
M6 : $5.8N \cdot m$ (59.2kgf · cm)max
- ※ Can not be mounted upside-down (mounted the top surface)
- ※ Keep free ventilation holes for cooling

FSB-150

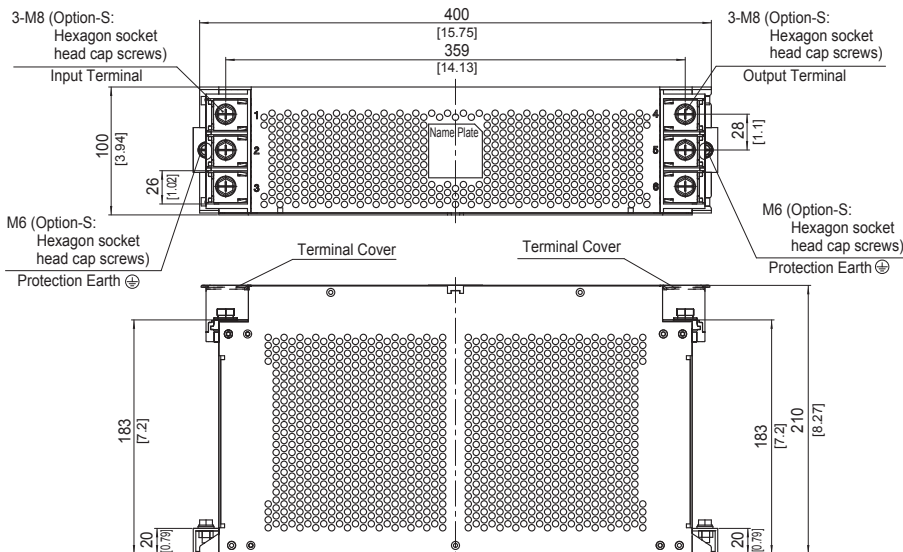

※ The air hole for heat radiation is not on the opposite side side.

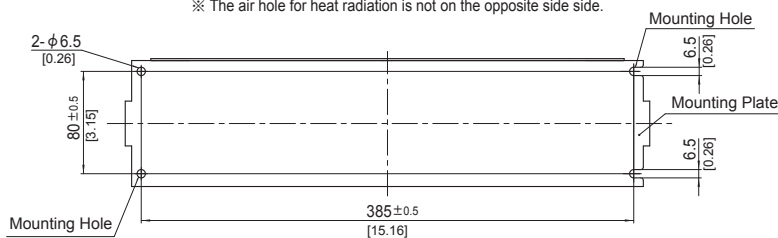

- ※ Tolerance : ± 1 [± 0.04]
- ※ Weight : 8.8kg max
- ※ Mounting Plate : Aluminum $t=2.0$ [0.08]
- ※ Dimensions in mm, []=inches
- ※ Terminal block screw tightening torque
M8 : $9.2N \cdot m$ (93.9kgf · cm)max
- ※ Protection Earth (PE) screw tightening torque
M6 : $5.8N \cdot m$ (59.2kgf · cm)max
- ※ Can not be mounted upside-down (mounted the top surface)
- ※ Keep free ventilation holes for cooling

FSB-80-693

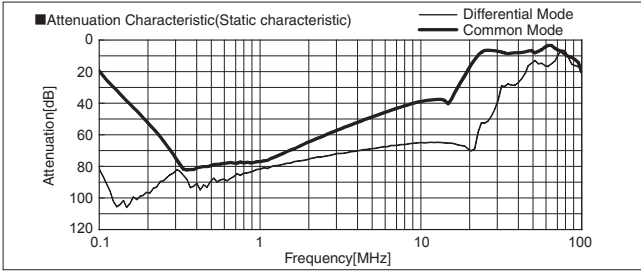

FSB-80-104

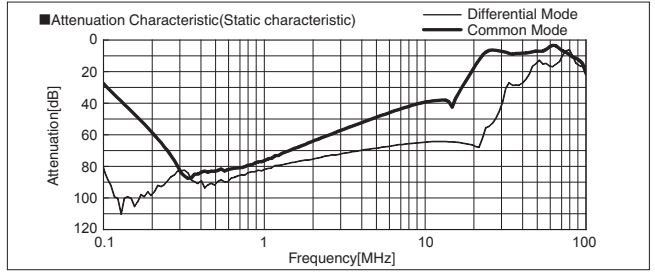

FSB-80-324

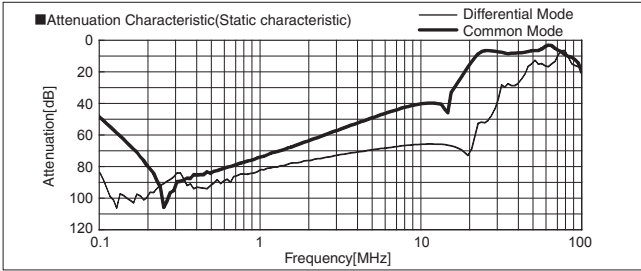

FSB-80-355

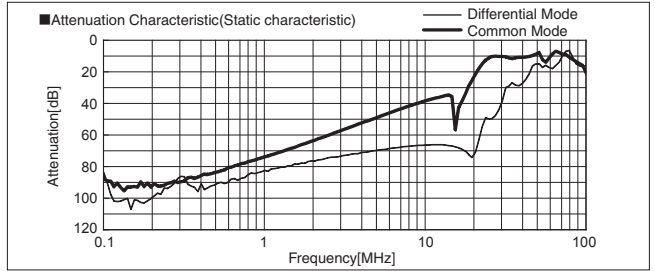

FSB-100-693

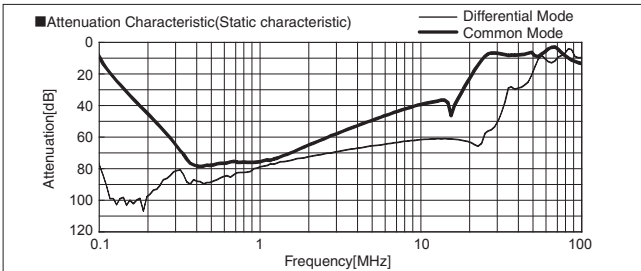

FSB-100-104

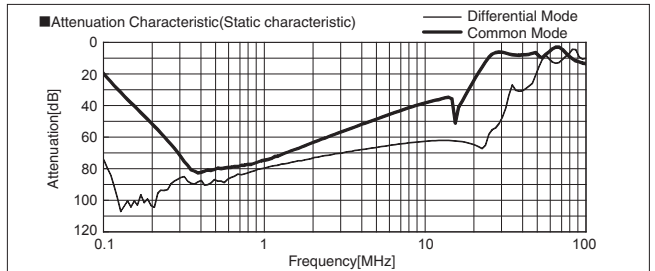

FSB-100-324

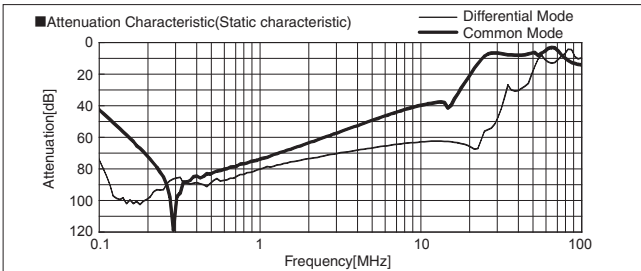

FSB-100-355

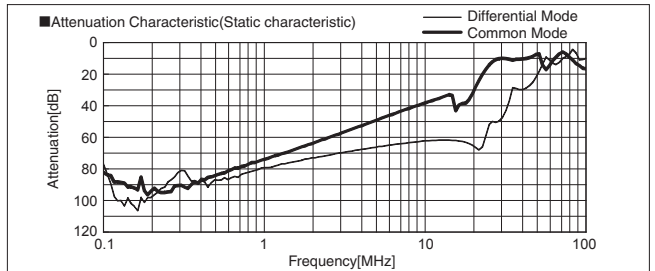

FSB-150-693

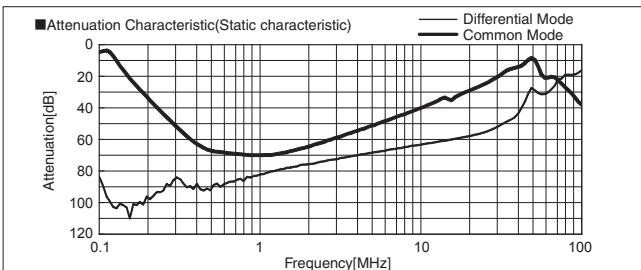

FSB-150-104

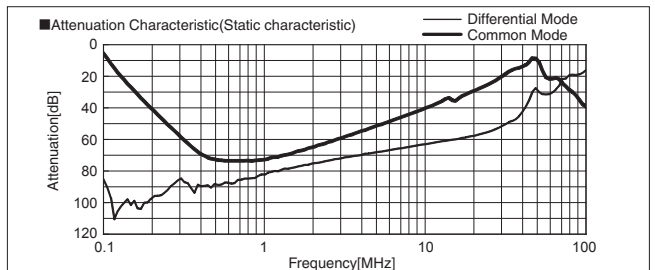

FSB-150-324

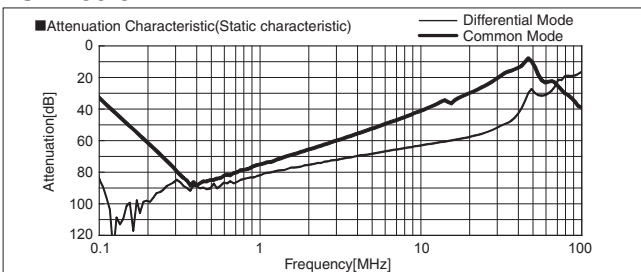

FSB-150-355

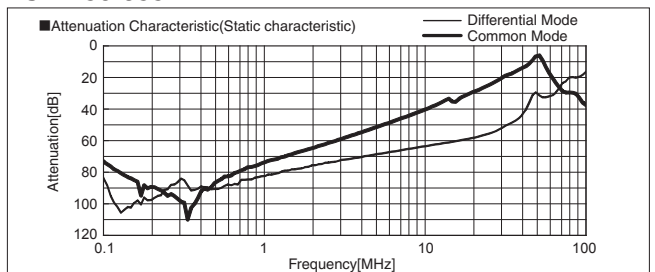

FSB-80-693-H

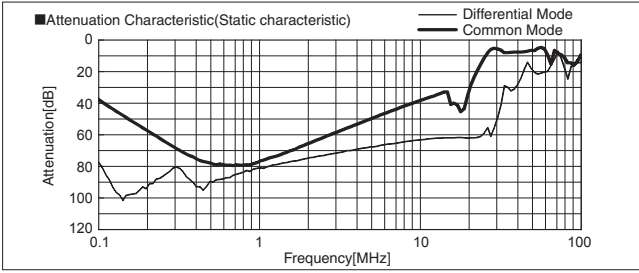

FSB-80-104-H

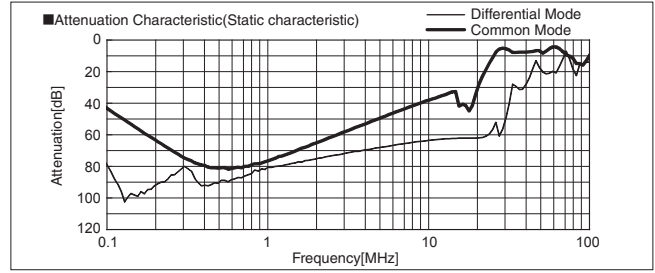

FSB-80-324-H

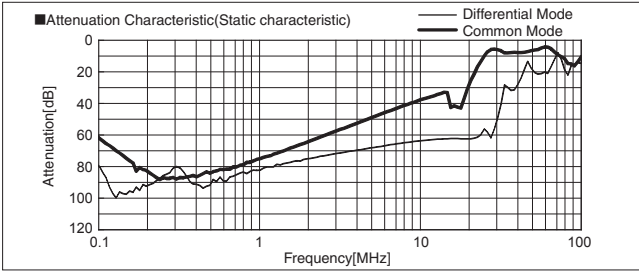

FSB-100-693-H

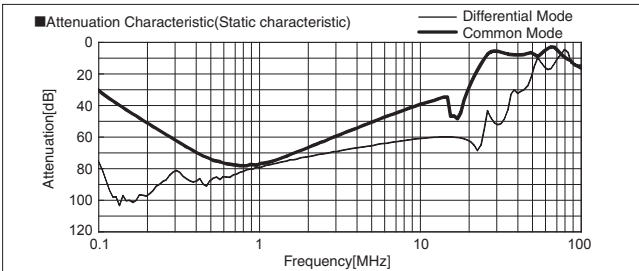

FSB-100-104-H

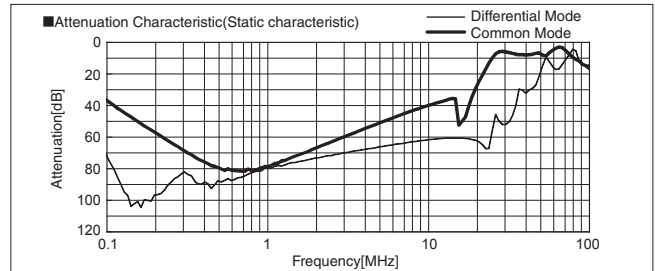

FSB-100-324-H

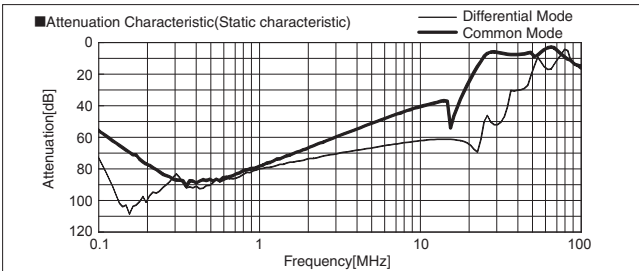

FSB-150-693-H

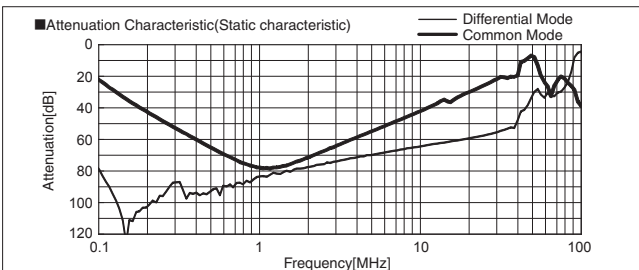

FSB-150-104-H

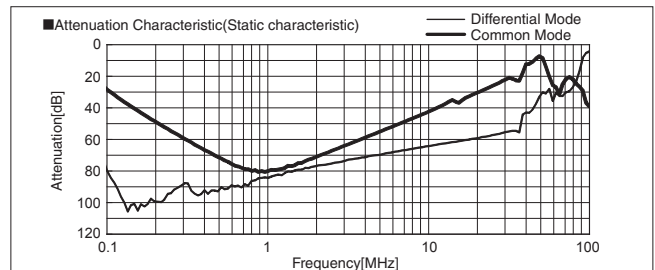

FSB-150-324-H

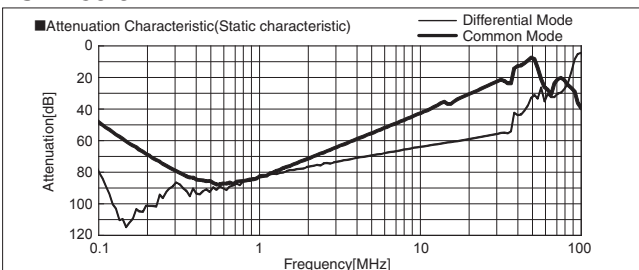

FSB-80-693-U

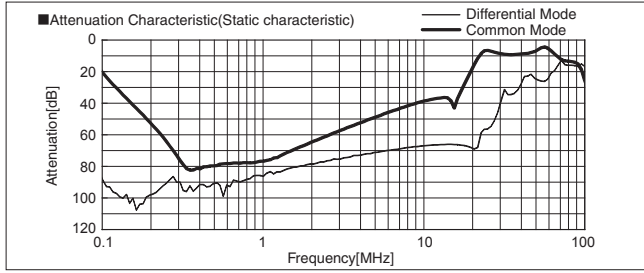

FSB-80-104-U

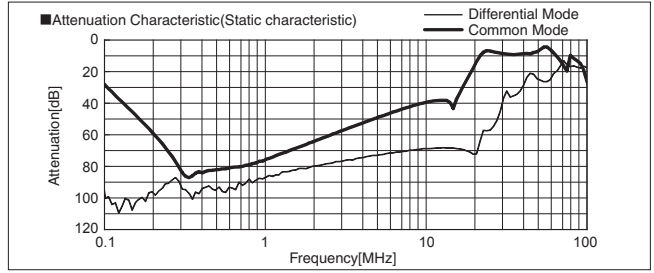

FSB-80-324-U

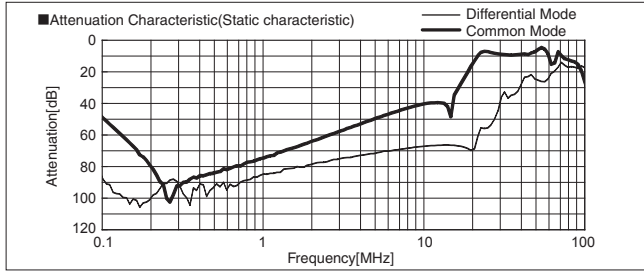

FSB-80-355-U

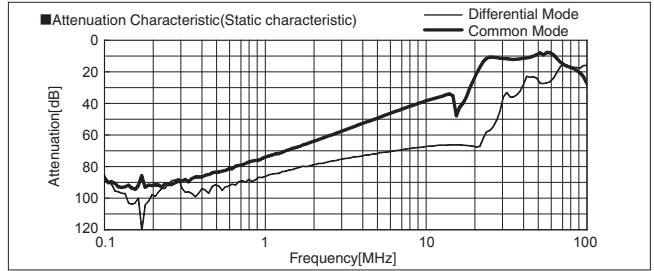

FSB-100-693-U

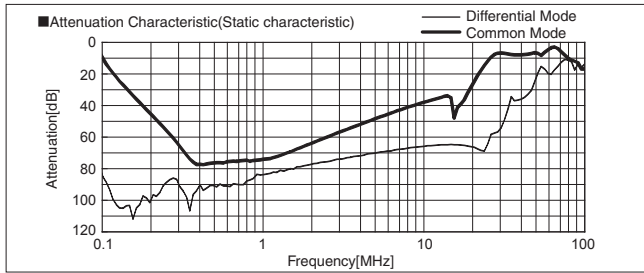

FSB-100-104-U

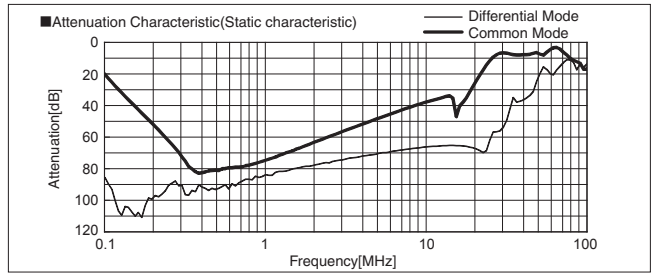

FSB-100-324-U

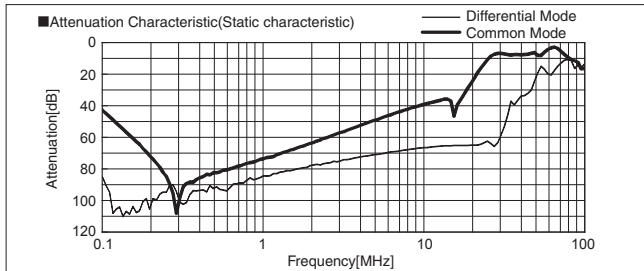

FSB-100-355-U

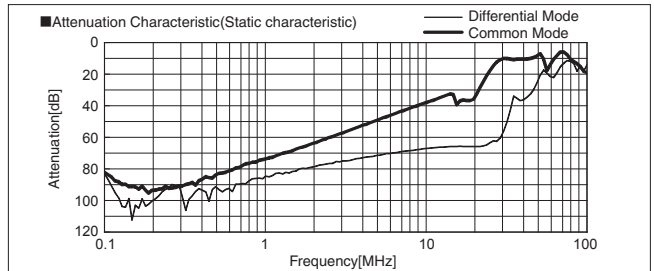

FSB-150-693-U

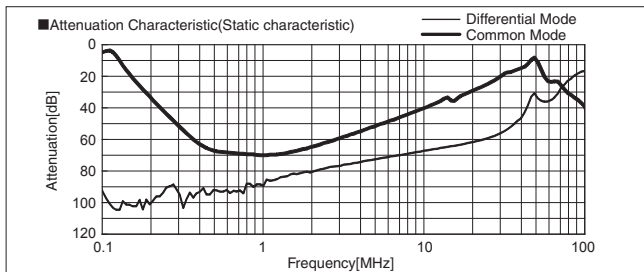

FSB-150-104-U

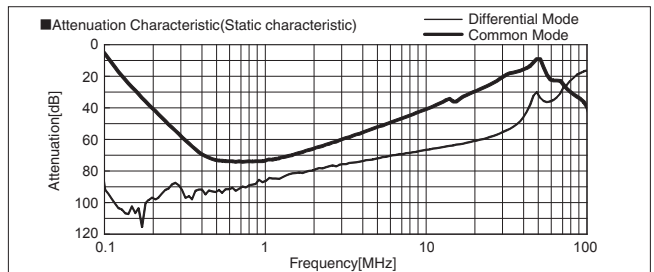

FSB-150-324-U

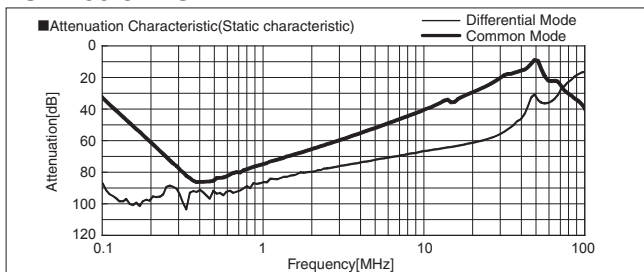

FSB-150-355-U

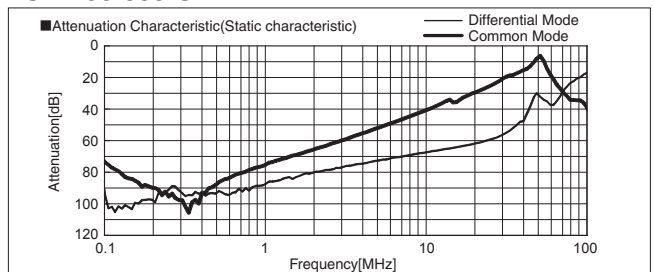

TSC series(400,600A)

TSC -600 -665 -□

① ② ③ ④

- ① Series Name
- ② Rated Current
- ③ Line to ground capacitor code: See table 1.1

table1.1 Line to ground capacitor code

Code	Leakage Current		Line to ground capacitor (nominal value)		
	Upper row : Δ-connection	Lower row : Y-connection	CY1	CY2	CY3
000*1	50μA/100μA max	50μA/100μA max	Not Provided	Not Provided	Not Provided
304*1	10.5mA/21.0mA max	1.5mA/3.0mA max	0.1μF	0.1μF	0.1μF
664*1	23mA/46mA max	3.5mA/7.0mA max	0.22μF	0.22μF	0.22μF
665*2	220mA/350mA max	20mA/40mA max	2.2μF	2.2μF	2.2μF

- * When the line to ground capacitor code is different, the attenuation characteristic is different.
- * Please contact us about low leakage current type (Change to low grounding capacitor).
- *1 Δ-connection : Input 250/500V 60Hz
Y-connection : Input 250/500V 60Hz
- *2 Δ-connection : Input 250/400V 60Hz
Y-connection : Input 250/500V 60Hz

- ④ Option
- H: Ultra high-attenuation type

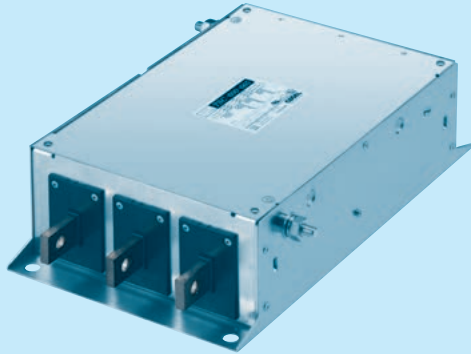

Features of TSC series

- Ultra high-attenuation type of common mode noise from 150kHz to 1MHz (Multi-stage filter)
- Input and output terminals : Busbar type
- Target application: Solar photovoltaic system, Large production equipment
- Selectable leakage current value

Specifications

No.	Items	TSC-400-665	TSC-600-665
1	Rated Voltage[V]	AC Three Phase 500(voltage range:528 max)	50/60Hz *3
2	Rated Current[A]	400	600
3	Test Voltage (Terminal-Mounting Plate)	3,600 VDC (Cutoff Current = 10mA), 1minute at room temperature and humidity	
4	Leakage current 250/500V 60Hz	20mA/40mA max (Y-connection)	
5	DC resistance	0.27mΩ max	0.2mΩ max
6	Safety agency approval temperatures	-25 to +85°C (Refer to Derating Curve)	
7	Operating temperature	-40 to +85°C (Refer to Derating Curve)	
8	Operating humidity	20 to 95%RH (Non condensing)	
9	Storage temperature/humidity	-40 to +85°C/20 to 95%RH (Non condensing)	
10	Vibration	10 to 55Hz, 9.8m/s ² (1G), 3min. Period, 1hour each X, Y and Z axis	
11	Impact	98.1m/s ² (10G), 11ms Once each X, Y and Z axis	
12	Safety agency approvals	UL1283, CSA C22.2 No.8 (C-UL) , DIN EN60939 VDE0565 Teil3-1, ENEC	
13	Case size (without projection)	210 X 100 X 360 mm [8.27 X 3.94 X 14.17 inches] (W X H X D)	
14	Weight	9.5kg max	10.0kg max

*3 Only capacitor code "665", Three Phase Δ-connection : 400 (440 max), Y-connection : 500 (528 max)

Circuit Diagram

(1) Line to ground capacitor code : 000

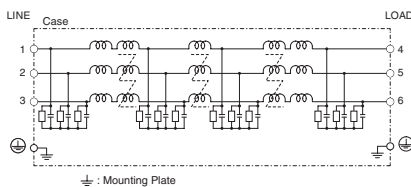

(2) Line to ground capacitor code : 304, 664, 665

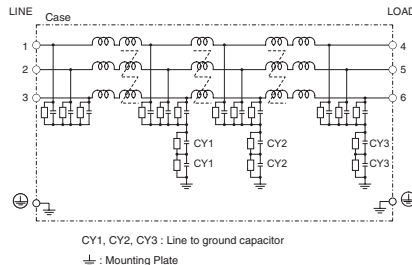

Derating Curve

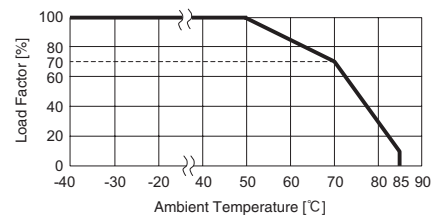

External view

TSC-400

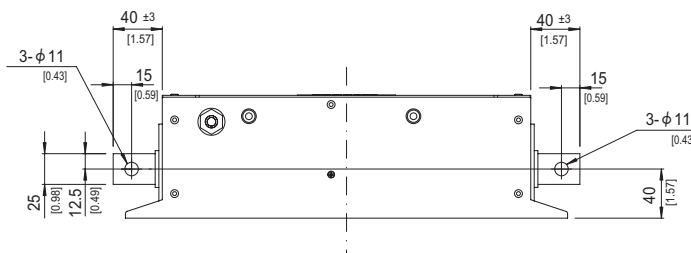
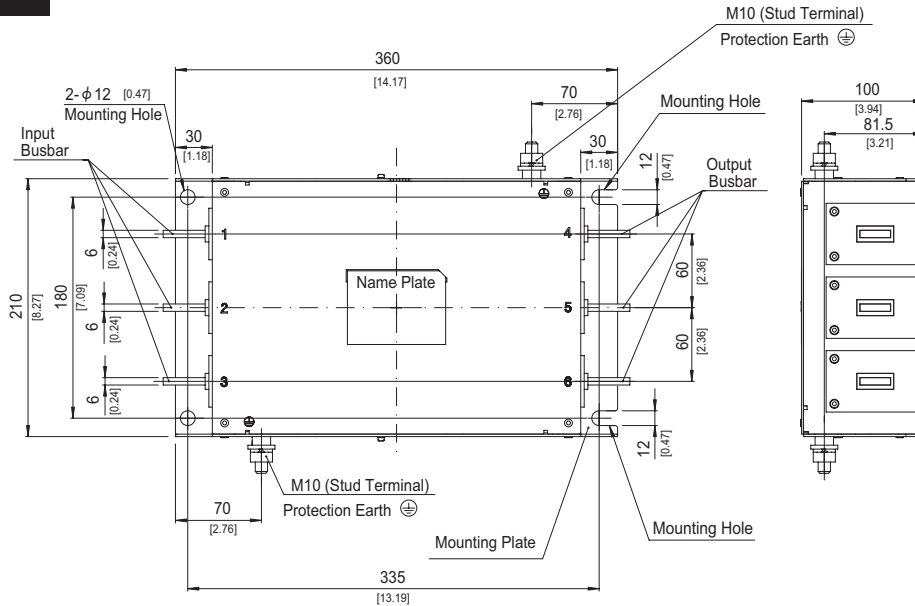

- ※ Tolerance : ± 1 [± 0.04]
- ※ Weight : 9.5kg max
- ※ Mounting Plate : Aluminum t=2.0 [0.08]
- ※ Busbar : Copper (Unplated) t=6.0 [0.24]
- ※ Dimensions in mm, []=inches
- ※ Protection Earth (PE) screw tightening torque
M10 : 14.2N · m (144.9kgf · cm)max
- ※ Can not be mounted upside-down
(mounted the top surface)

TSC-600

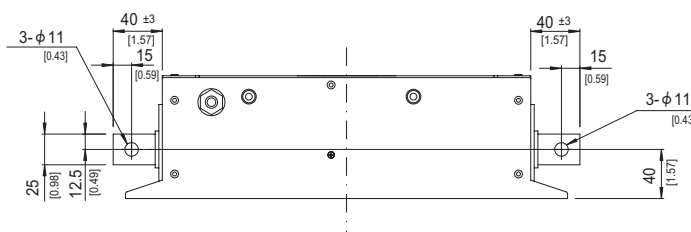
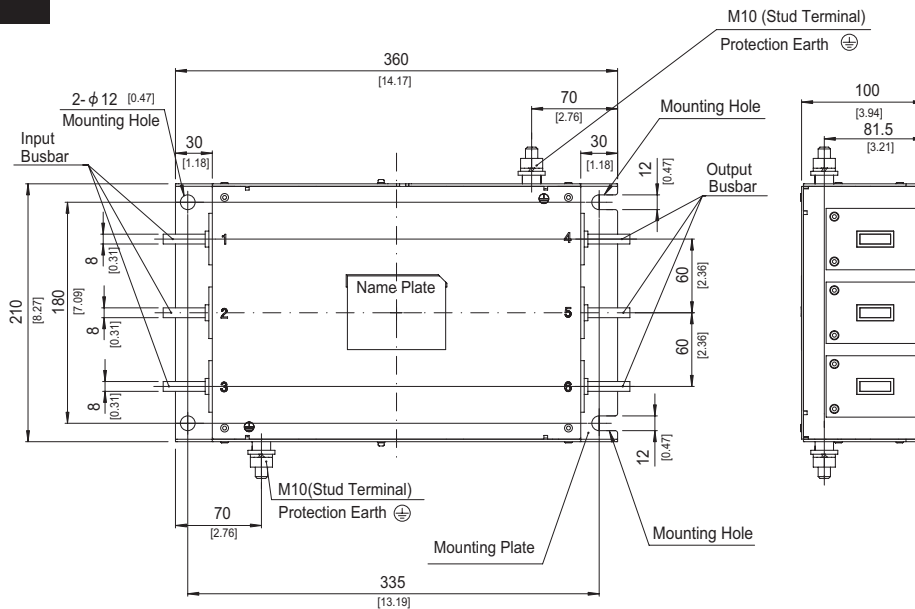

- ※ Tolerance : ± 1 [± 0.04]
- ※ Weight : 10.0kg max
- ※ Mounting Plate : Aluminum t=2.0 [0.08]
- ※ Busbar : Copper (Unplated) t=8.0 [0.31]
- ※ Dimensions in mm, []=inches
- ※ Protection Earth (PE) screw tightening torque
M10 : 14.2N · m (144.9kgf · cm)max
- ※ Can not be mounted upside-down
(mounted the top surface)

TSD series(400,600A)

TSD -600 -186

① ② ③

- ① Series Name
- ② Rated Current
- ③ Line to ground capacitor code: See table 1.1

table 1.1 Line to ground capacitor code

Code	Leakage Current *1 Upper row : Δ-connection Lower row : Y-connection	Line to ground capacitor (nominal value)		
		CY1	CY2	CY3
105	45mA/70mA max 3.5mA/7mA max	0.22μF	0.1μF	0.22μF
215	80mA/130mA max 7.5mA/15mA max	1.0μF	0.1μF	1.0μF
136	420mA/660mA max 40mA/80mA max	2.2μF	2.2μF	2.2μF
186	540mA/850mA max 50mA/100mA max	2.2μF	2.2μF	2.2μF

* When the line to ground capacitor code is different, the attenuation characteristic is different.

* Please contact us about low leakage current type. (Change to low grounding capacitor)

*1 Δ-connection : Input 250/400V 60Hz
Y-connection : Input 250/500V 60Hz

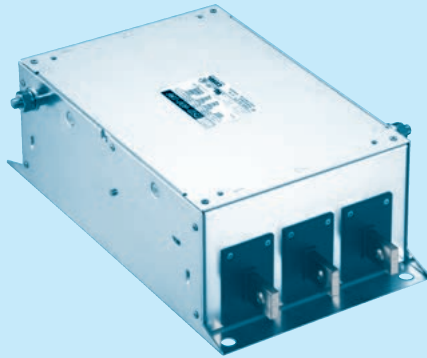

Features of TSD series

Ultra high-attenuation type for motor drive system (Multi-functional regenerative converter)

- Improve saturation resistance
- Input and output terminals : Busbar type
- Target application: Large equipment with Multi-functional regenerative convertor (Transferred equipment, Air conditioning equipment)

Specifications

No.	Items	TSD-400-186	TSD-600-186
1	Rated Voltage[V]	AC Three Phase Y-connection 500 (voltage range:528 max) 50/60Hz *2	
2	Rated Current[A]	400	600
3	Test Voltage (Terminal-Mounting Plate)	3,600 VDC (Cutoff Current = 10mA), 1minute at room temperature and humidity	
4	Leakage current 250/500V 60Hz	50mA/100mA max (Y-connection)	
5	DC resistance	0.27mΩ max	0.2mΩ max
6	Safety agency approval temperatures	-40 to +85°C (Refer to Derating Curve)	
7	Operating temperature	-40 to +85°C (Refer to Derating Curve)	
8	Operating humidity	20 to 95%RH (Non condensing)	
9	Storage temperature/humidity	-40 to +85°C/20 to 95%RH (Non condensing)	
10	Vibration	10 to 55Hz, 9.8m/s ² (1G), 3min. Period, 1hour each X, Y and Z axis	
11	Impact	98.1m/s ² (10G), 11ms Once each X, Y and Z axis	
12	Safety agency approvals	UL60939, CSA C22.2 No.8 (C-UL), EN60939(DEMKO), ENEC	
13	Case size (without projection)	210×125×360 mm [8.27×4.92×14.17 inches] (W×H×D)	
14	Weight	10.0kg max	10.5kg max

*2 Three Phase Δ-connection:400V (440V max)

Circuit Diagram

(1) Line to ground capacitor code : 105

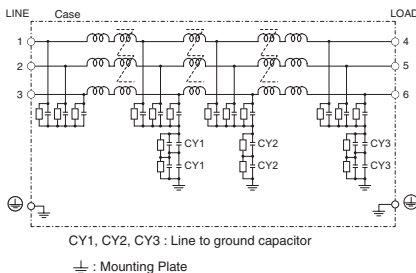

(2) Line to ground capacitor code : 215

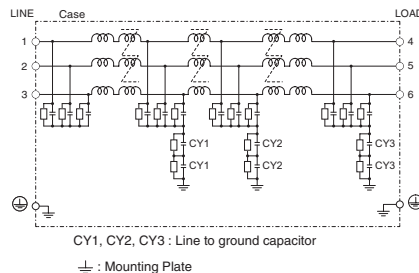

(3) Line to ground capacitor code : 136

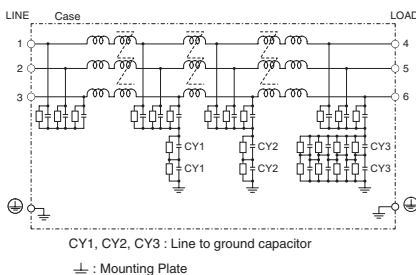

(4) Line to ground capacitor code : 186

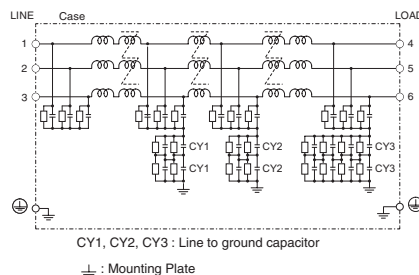

Derating Curve

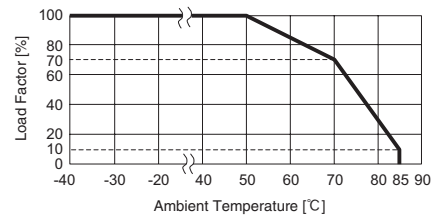

External view

TSD-400

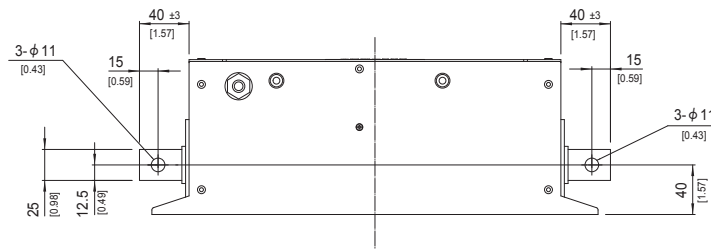
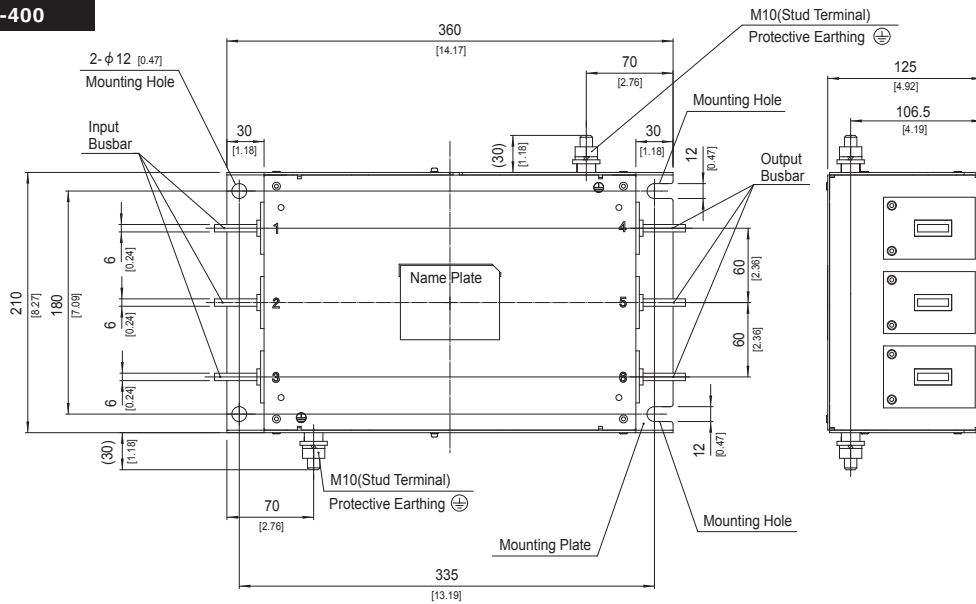

- ※ Dimensions in mm, [] = inches
- ※ Tolerance : ±1 [±0.04]
- ※ Weight : 10.0kg max
- ※ Mounting Plate : Aluminum t = 2.0 [0.08]
- ※ Busbar : Copper (Unplated) t = 6.0 [0.24]
- ※ Protective Earthing (PE) screw tightening torque M10 : 14.2N · m max
- ※ Can not be mounted upside-down (mounted the top surface)

TSD-600

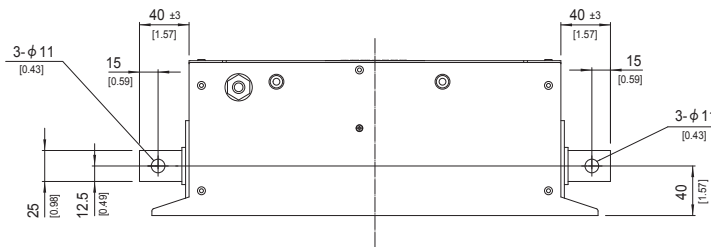
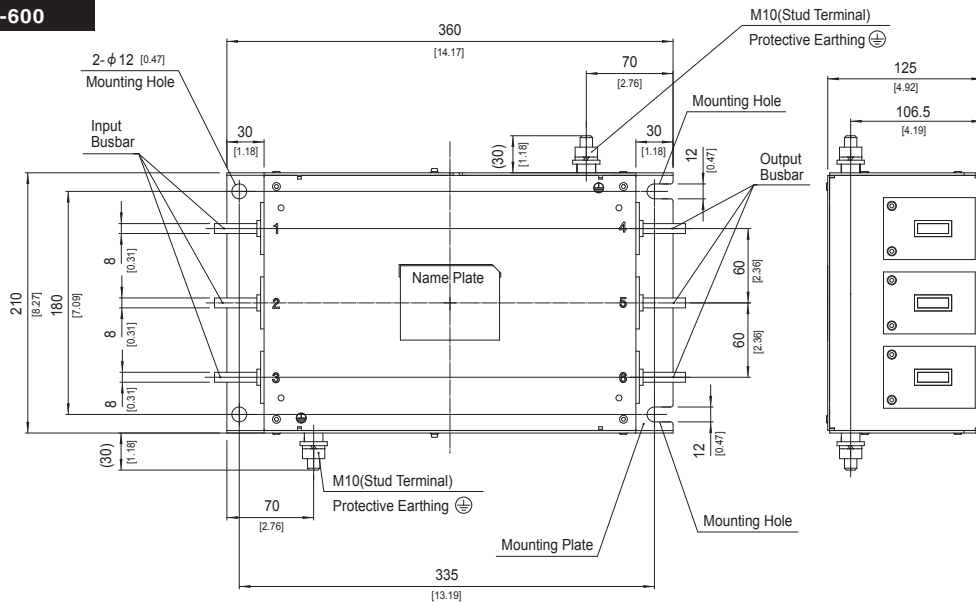

- ※ Dimensions in mm, [] = inches
- ※ Tolerance : ±1 [±0.04]
- ※ Weight : 10.5kg max
- ※ Mounting Plate : Aluminum t = 2.0 [0.08]
- ※ Busbar : Copper (Unplated) t = 8.0 [0.31]
- ※ Protective Earthing (PE) screw tightening torque M10 : 14.2N · m max
- ※ Can not be mounted upside-down (mounted the top surface)

TSD series(800,1000A)

TSD -1000 -356

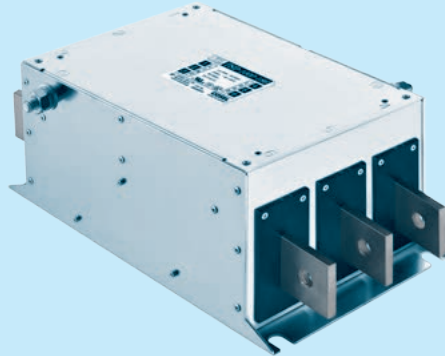

- ① Series Name
- ② Rated Current
- ③ Line to Ground Capacitor Code: See Table 1.1

Table 1.1 Line to Ground Capacitor Code

Code	Leakage Current Upper row : Δ-Connection Lower row : Y-Connection	Line to Ground Capacitor (Nominal Value)		
		CY1	CY2	CY3
000 *1	50uA/100uA max 50uA/100uA max	Not Provided	Not Provided	Not Provided
304 *1	10.5mA/21.0mA max 1.5mA/3.0mA max	0.1μF X1	0.1μF X1	0.1μF X1
664 *1	23mA/46mA max 3.5mA/7.0mA max	0.22μF X1	0.22μF X1	0.22μF X1
316 *2	960mA/1500mA max 90mA/180mA max	2.2μF X2	2.2μF X2	2.2μF X10
356 *2	1080mA/1700mA max 100mA/200mA max	2.2μF X4	2.2μF X4	2.2μF X8
446 *2	1300mA/2100mA max 110mA/220mA max	2.2μF X5	2.2μF X5	2.2μF X10

*When the line to ground capacitor code is different, the attenuation characteristic is different.

*Please contact us about low leakage current type (Change to low grounding capacitor).

*1 Δ-Connection : Input 250/500V 60Hz
Y-Connection : Input 250/500V 60Hz

*2 Δ-Connection : Input 250/400V 60Hz
Y-Connection : Input 250/400V 60Hz

Features of TSD series

Ultra high-attenuation type for motor drive system (Multi-functional regenerative converter)

- Improve saturation resistance
- Input and output terminals : Busbar type
- Target application: Large equipment with Multi-functional regenerative convertor (Transferred equipment, Air conditioning equipment)

Specifications

No.	Items	TSD-800-356	TSD-1000-356
1	Rated Voltage	[VAC]	Three-phase Y-Connection 500 (Voltage Range:528 max) 50/60Hz *3
		[VDC]	610
2	Rated Current[A]	800	1000
3	Test Voltage (Terminal-Mounting Plate)	3,600 VDC (Cutoff Current = 10mA), 1minute at room temperature and humidity *4	
4	Leakage Current 250/500V 60Hz (Y-Connection)	100mA / 200mA max	
5	DC Resistance	0.1mΩ max	
6	Operating Temperature/Humidity	-40 to +85°C (Refer to Derating Curve)/20 to 95%RH (Non condensing)	
7	Storage Temperature/Humidity	-40 to +85°C/20 to 95%RH (Non condensing)	
8	Vibration	10 to 55Hz, 9.8m/s ² (1G), 3min. Period, 1hour each X, Y and Z axis	
9	Impact	98.1m/s ² (10G), 11ms Once each X, Y and Z axis	
10	Safety Agency Approvals	UL60939 [Overvoltage Category : III Altitude : 3000m], CSA C22. 2 No. 8 (C-UL) EN60939 (DEMKO) [Overvoltage Category: III Altitude : 3000m], ENEC	
11	Case Size (Without Projection)	190 X 155 X 346mm (W×H×D) [7.48 X 6.10 X 13.62 inches] (W X H X D)	
12	Weight	11.5kg max	

*3 Line to Ground Capacitor Code 「186」, 「356」, 「446」, Three-Phase Δ-Connection:400V (440V max), Three-Phase Y-Connection:500V (528V max)

*4 Line to Ground Capacitor Code 「000」, 2,500 VAC (Cutoff Current = 5mA), 1minute at room temperature and humidity

Circuit Diagram

(1) Line to Ground Capacitor Code : 000

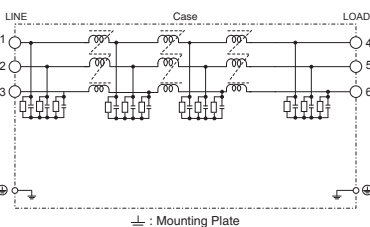

(2) Line to Ground Capacitor Code : 304, 664, 316, 356, 446

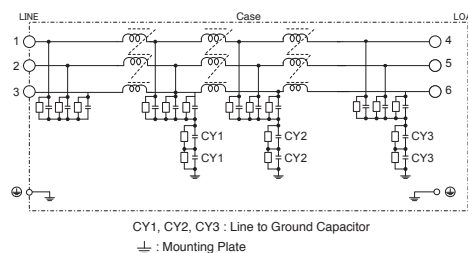

Derating Curve

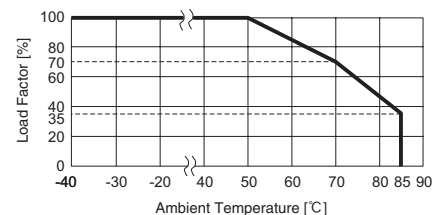

External view

TSD-800/1000-□□□

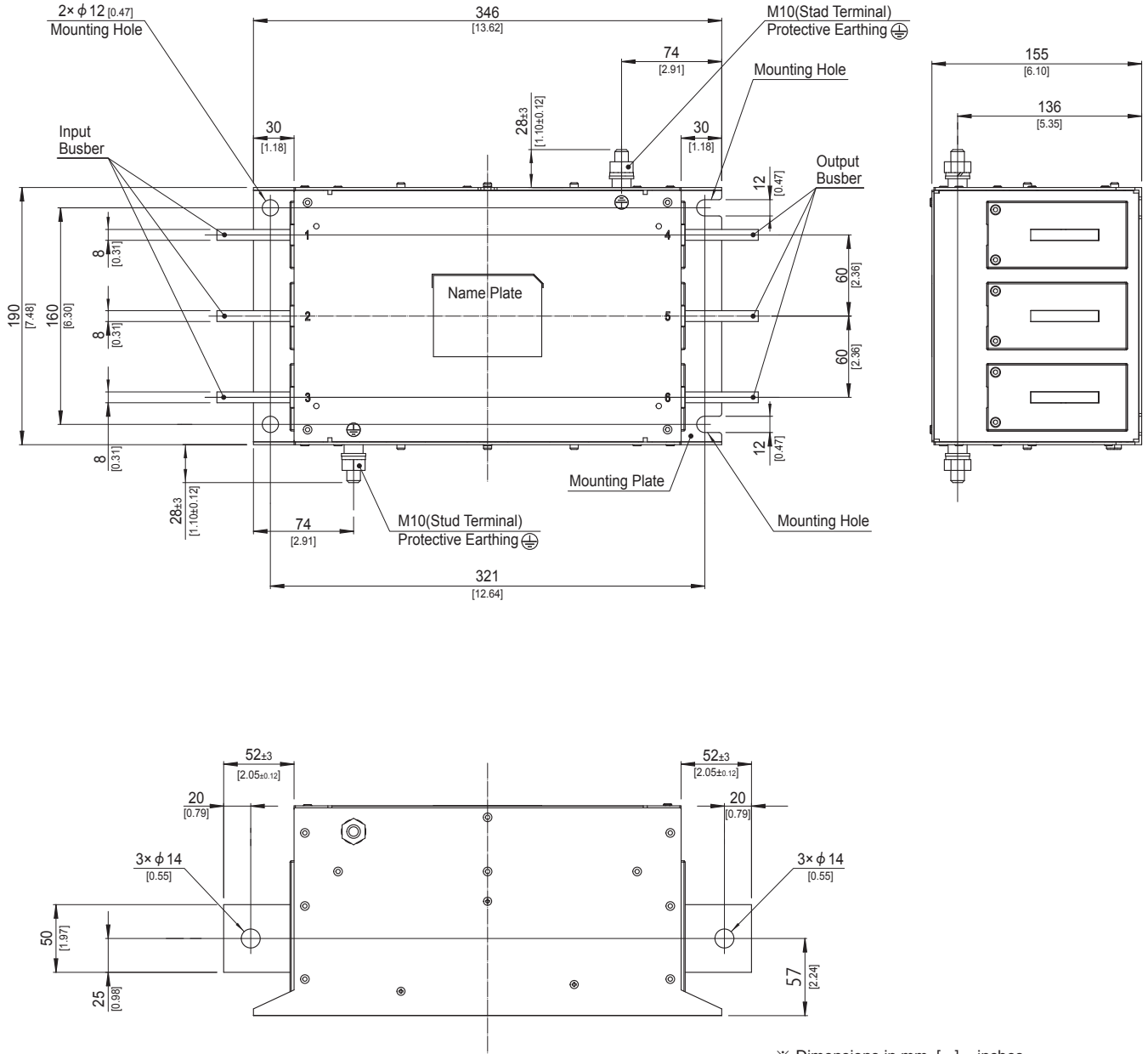

- ※ Dimensions in mm, [] = inches
- ※ Tolerance : ± 1 [± 0.04]
- ※ Weight : 11.5kg max
- ※ Mounting plate Material : Aluminum t = 2.0 [0.08]
- ※ Busber Material : Copper (Unplated) t = 8.0 [0.31]
- ※ Protective Earthing(PE) screw tightening torque M10 : 14.2N · m max
- ※ Can not be mounted upside-down (Mounted the top surface)

TSC-400-000/TSC-600-000

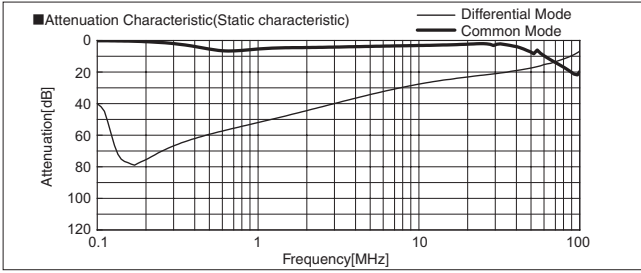

TSC-400-304/TSC-600-304

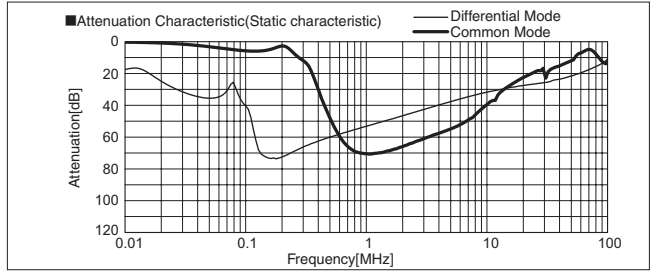

TSC-400-664/TSC-600-664

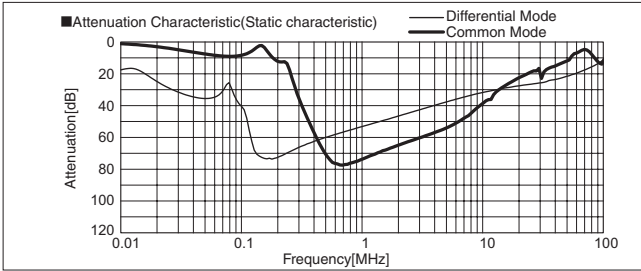

TSC-400-665/TSC-600-665

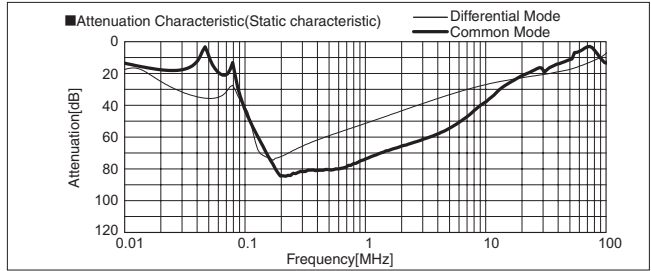

TSC-400-000-H/TSC-600-000-H

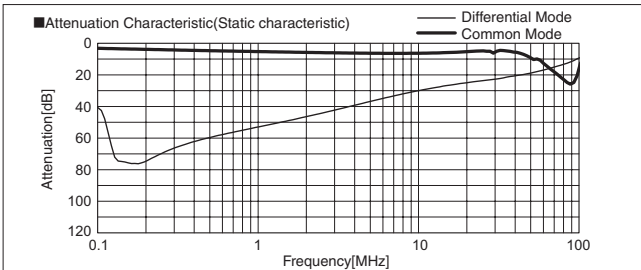

TSC-400-304-H/TSC-600-304-H

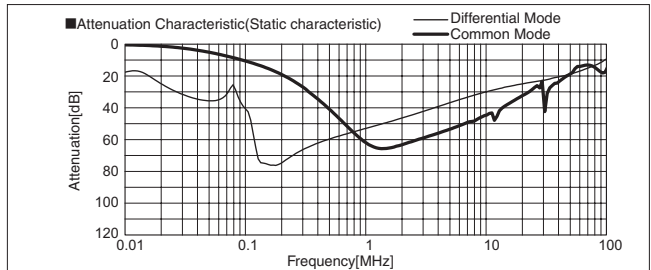

TSC-400-664-H/TSC-600-664-H

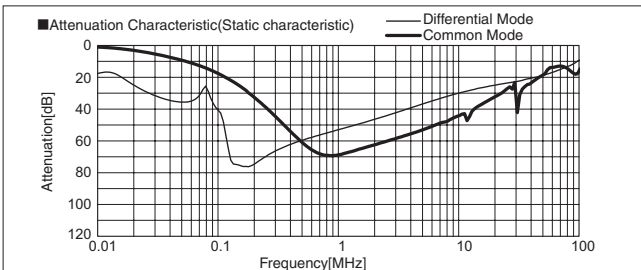

TSC-400-665-H/TSC-600-665-H

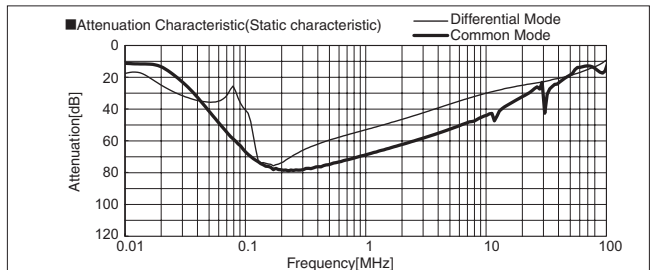

TSD-400-105/TSD-600-105

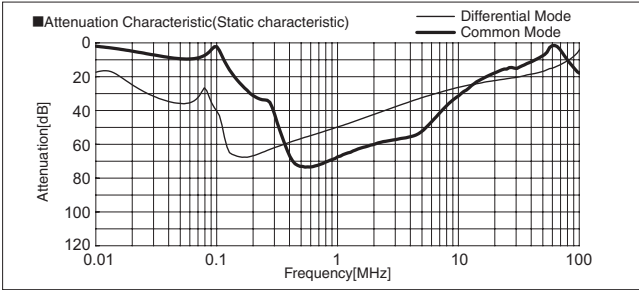

TSD-400-215/TSD-600-215

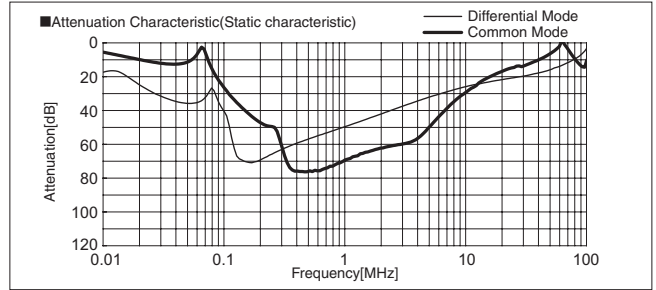

TSD-400-136/TSD-600-136

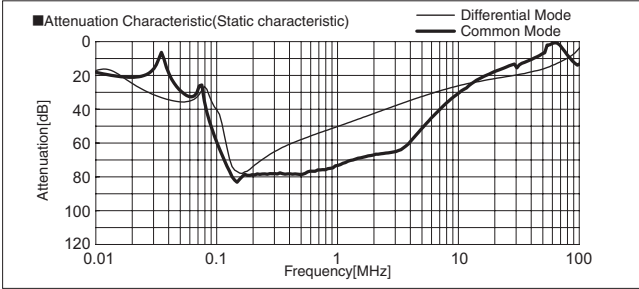

TSD-400-186/TSD-600-186

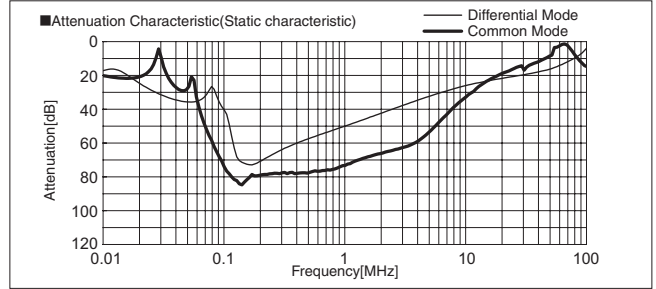

TSD-800-000/TSD-1000-000

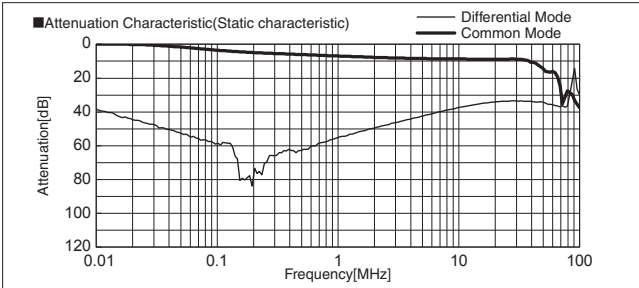

TSD-800-304/TSD-1000-304

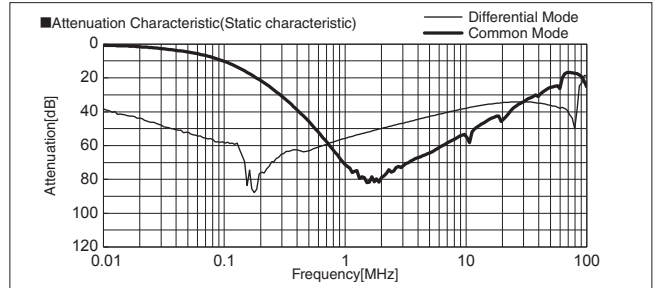

TSD-800-664/TSD-1000-664

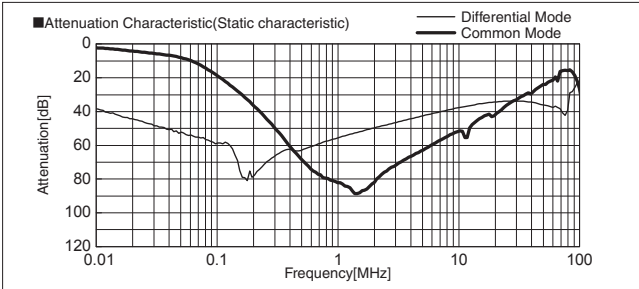

TSD-800-316/TSD-1000-316

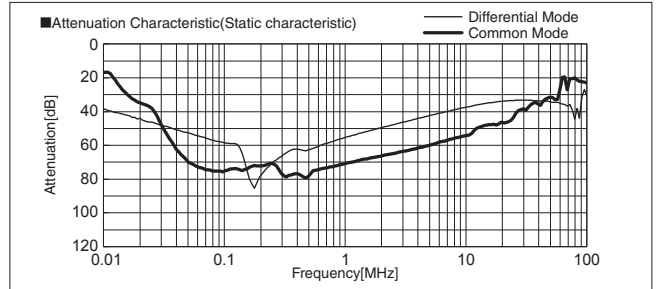

TSD-800-356/TSD-1000-356

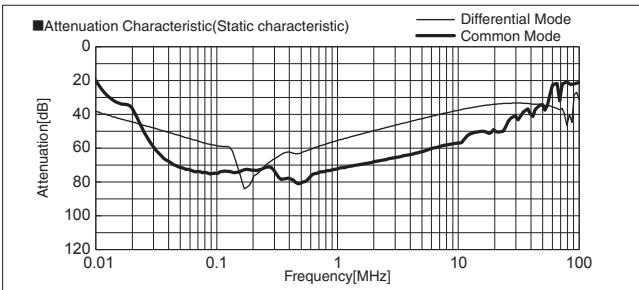

TSD-800-446/TSD-1000-446

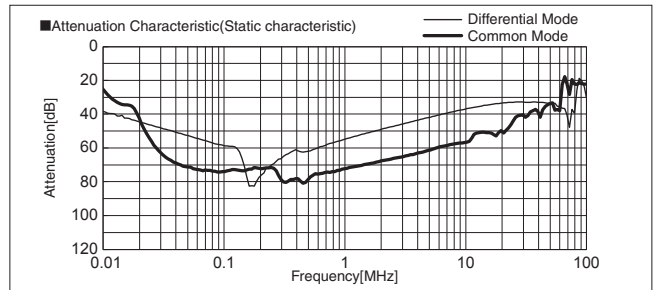

1 Busbar Connection Method

(1)TSC/TSD-400/600

When wiring an M10 terminal to the busbar, the external dimension of the crimp terminal is critical in maintaining isolation distance between insulating resin, chassis, and mounting screws. We therefore recommend that you use terminals of the dimensions shown in table 1.1.

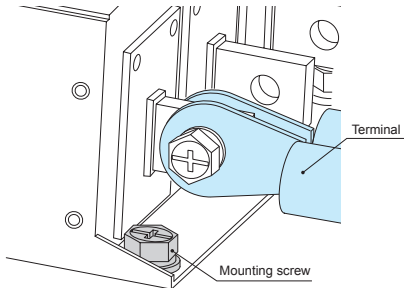

Fig.1.1 Busbar connection

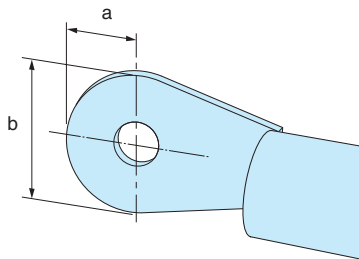

Fig.1.2 Terminals dimension

table.1.1 Selected conditions terminals dimension

Model Name	"a"Allowable dimension	"b"Allowable dimension
TSC/TSD series	19.5mm max	38.5mm max

(2)TSC/TSD-800/1000

For TSD (800A/1000A), bus bar connection is recommended. When making bus-bar connections, be careful to avoid interference with insulating resin parts and to maintain an insulation distance from the chassis and adjacent terminals.

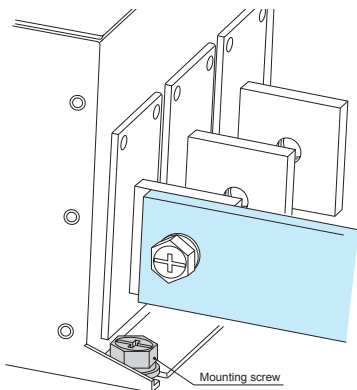

Fig.1.3 Busbar Connection

2 Notes on wiring and storage

■ Notes on wiring

Since the (copper) busbar has not been surface treated, surface oxidation may form a resistive layer between the contacts. We therefore recommend abrasion of all mating surfaces before, and wearing gloves during, all wiring work. Please be careful not to leave fingerprints.

■ Notes on storage

Please avoid storage in environments where copper corrosion is concerned. Storage under a normal temperature and humidity environment is recommended.

1 Method of connecting EMI/EMC Filter

(1) Single-phase

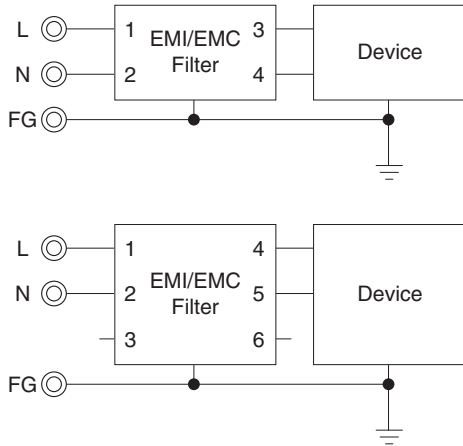

※Three-phase three-wire EMI/EMC filter is also available as a Single-phase input type.

(2) Three-phase three-wire

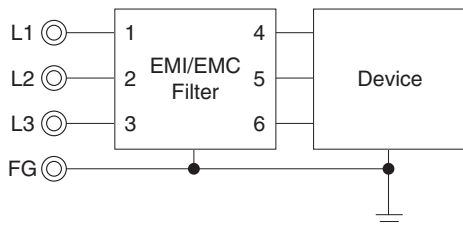

(3) Three-phase four-wire

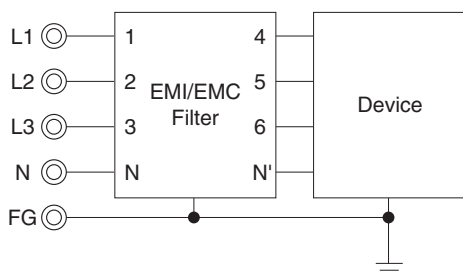

[Reference] Example of calculating input current calculation

Input voltage 400 [V]
Input capacity of the equipment 4000 [VA]

$$\text{Input current} = \frac{4000 \text{ [VA]}}{400 \text{ [V]} \times \sqrt{3}} = 5.8 \text{ [A]}$$

2 Caution when connecting EMI/EMC Filter

Please note the excessive temperature increase of EMI/EMC filter. Please contact us if judgement is difficult.

(1) Input voltage and frequency

Please use within the rated voltage (or maximum voltage) of each model.

Input frequency specification for AC input EMI/EMC filter is considered as commercial frequency (50/60Hz).

It should not be used under the following conditions.

- 1) Distorted input voltage waveform.
(Triangle wave, square wave etc.)
- 2) High input frequency (ex: 400Hz)

(2) Input current

Please use within the rated current of each model.

EMI/EMC filters have short term peak current capability. Therefore, it can flow ~40A or ten times of rated current, non-repeated, within a few ms such as inrush current of power supply etc.

However, it should not be used under the following conditions.

- 1) Long duration peak current.
- 2) Peak current or high-frequency current is continuously flowing.

(3) Connection to a general-purpose inverter (servo driver)

Please connect EMI/EMC filter to input side of inverter driver (servo driver).

It should not be used between the inverter (servo driver) and the motor.

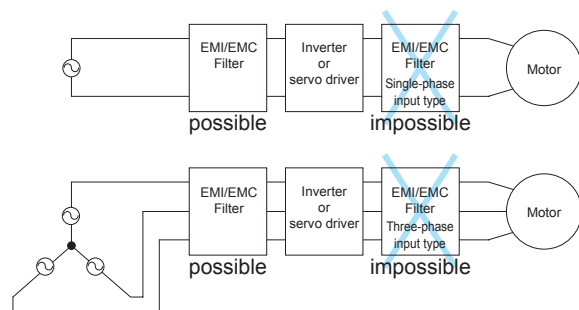

(4) Caution when a Three-phase four-wire system

Three-phase three-wire system input voltage is not supported. The neutral line(N phase) must be connected.

If you have a Three-phase four-wire system with a Single-phase load connected between the neutral and each line, the neutral may carry considerably more current than the line current.

Please use this while ensuring that the input current does not exceed the rated current of the EMI/EMC filter.

3 Safety Considerations

- To apply for safety standard approval using this EMI/EMC Filter, the following conditions must be met.
- The unit must be used as a component of an end-use equipment.
- Protection earth terminal (PE) must be connected to safety ground of end-use equipment.

SNA series (1A,3A)

SNA -03 -223 -□

① ② ③ ④

- ① Model Name
- ② Rated Current
- ③ Line to ground capacitor code: See table 1.1.

table 1.1 Line to ground capacitor code

Code	Line to ground capacitor (nominal value)
000	Not Provided
223	22000pF

- ④ Options
- D: DIN rail installation type

* The dimensions change when the option is set. Refer to External view.

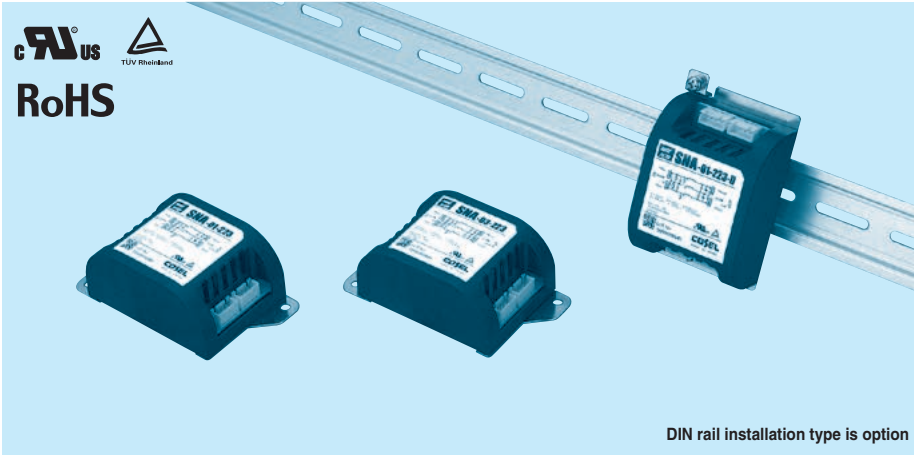

RoHS

Features of SNA series (1A and 3A)

Ripple noise attenuation type for switch mode power supplies(DC)

- ±50 VDC
- Best filter for switch mode power supplies of analog circuits (ex. power supply filter for an operational amplifier)

Specifications

No.	Items	SNA-01-223	SNA-03-223
		Interface: Connector	
1	Rated Voltage DC[V]	±50 (+Vin - COM-in, -Vin - COM-in)	
2	Rated Current DC[A]	1	3
3	Test Voltage (Terminal-Mounting Plate)	500 VAC (Cutoff Current = 100mA), 1minute at room temperature and humidity	
4	Isolation Resistance (Terminal-Mounting Plate)	500 VDC 50MΩ min at room temperature and humidity	
5	DC resistance	190mΩ max	90mΩ max
6	Operating temperature	-40 to +71°C (Refer to Derating Curve)	
7	Operating humidity	20 to 95%RH (Non condensing)	
8	Storage temperature/humidity	-40 to +75°C/20 to 95%RH (Non condensing)	
9	Vibration	10 to 55Hz, 19.6m/s ² (2G), 3min. Period, 1hour each X, Y and Z axis	
10	Impact	196.1m/s ² (20G), 11ms Once each X, Y and Z axis	
11	Safety agency approvals	UL60950-1, C-UL (CSA60950-1), EN62368-1	
12	Case size (without projection) /Weight	52 X 35 X 93 mm [2.05 X 1.38 X 3.66 inches] (W X H X D) /130g max (Option : -D refer to external view)	

Circuit Diagram

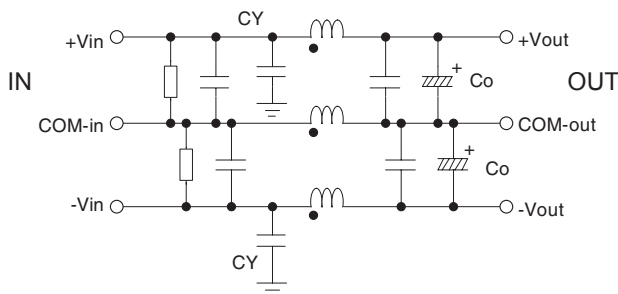

CY : Line to ground capacitor Co : Electrolytic capacitor : Mounting Plate

■ Expected life : 10 years

Derating Curve

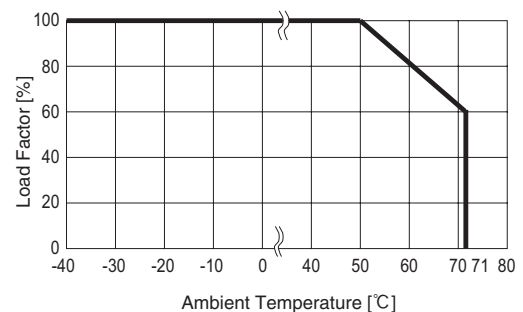

External view

Standard Type

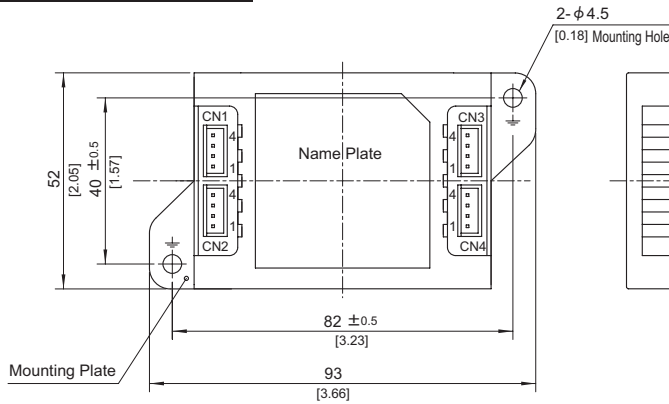

CN1	
Pin No.	Function
1,2	COM-in
3,4	+Vin

CN3	
Pin No.	Function
1,2	COM-out
3,4	+Vout

CN2	
Pin No.	Function
1,2	-Vin
3,4	COM-in

CN4	
Pin No.	Function
1,2	-Vout
3,4	COM-out

I/O Connector	Mating connector	Terminal
CN1-CN4	B4B-XH-AM	XHP-4
		Reel: SXH-001T-P0.6
		Bulk: BXH-001T-P0.6

(Mfr.: J.S.T)

Option harness : Refer to Instruction Manual 4

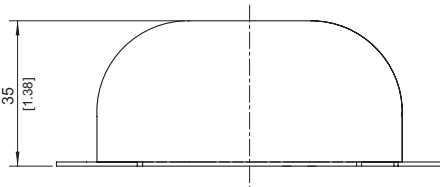

※ Tolerance : ±1 [±0.04]

※ Weight : 130g max

※ PCB Material /thickness : CEM3 /1.6mm [0.06 inches]

※ Mounting plate : Iron (surface finishing : nickel plating) t=1.0 [0.04]

※ Case : PBT

※ Dimensions in mm, []=inches

※ Keeping drawing current per pin below 2A for CN1 to CN4

DIN rail installation Type

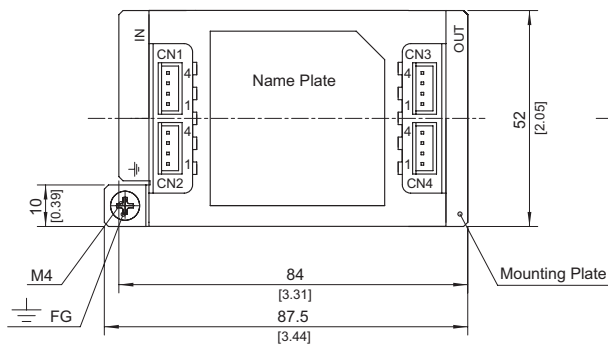

CN1	
Pin No.	Function
1,2	COM-in
3,4	+Vin

CN3	
Pin No.	Function
1,2	COM-out
3,4	+Vout

CN2	
Pin No.	Function
1,2	-Vin
3,4	COM-in

CN4	
Pin No.	Function
1,2	-Vout
3,4	COM-out

I/O Connector	Mating connector	Terminal
CN1-CN4	B4B-XH-AM	XHP-4
		Reel: SXH-001T-P0.6
		Bulk: BXH-001T-P0.6

(Mfr.: J.S.T)

Option harness : Refer to Instruction Manual 4

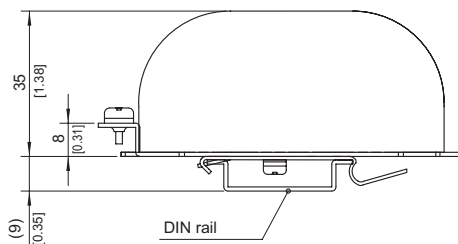

※ Tolerance : ±1 [±0.04]

※ Weight : 140g max

※ PCB Material /thickness : CEM3 /1.6mm [0.06 inches]

※ Mounting plate : Iron (surface finishing : nickel plating) t=1.0 [0.04]

※ Case : PBT

※ Dimensions in mm, []=inches

※ Keeping drawing current per pin below 2A for CN1 to CN4

■Note when installing the EMI/EMC Filter on a DIN rail.

When the EMI/EMC Filter is grounded through the DIN rail, the proper noise attenuation may not be achieved.

Be sure to connect the FG terminal of the EMI/EMC Filter body to the earth.

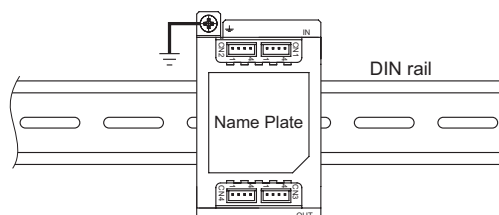

SNA series (6A)

SNA -06 -223 -□

① ② ③ ④

- ① Model Name
- ② Rated Current
- ③ Line to ground capacitor code: See table 1.1.

table 1.1 Line to ground capacitor code

Code	Line to ground capacitor (nominal value)
000	Not Provided
223	22000pF

- ④ Options
- D :DIN rail installation type
- T :Terminal block type
- DT :Terminal block and DIN rail type

* The dimensions change when the option is set. Refer to External view.

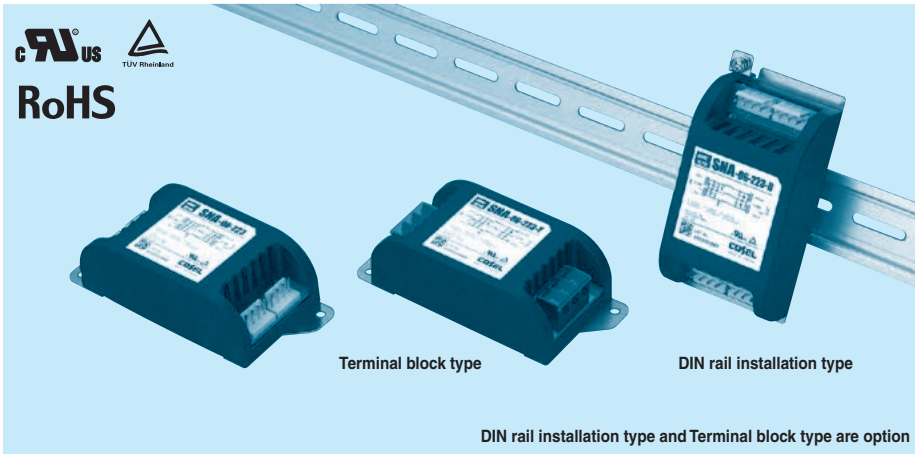

RoHS

Terminal block type

DIN rail installation type

DIN rail installation type and Terminal block type are option

Features of SNA series (6A)

Ripple noise attenuation type for switch mode power supplies(DC)

· ±50 VDC

· Best filter for switch mode power supplies of analog circuits

(ex. power supply filter for an operational amplifier)

Specifications

No.	Items	SNA-06-223
		Interface:Connector
1	Rated Voltage DC[V]	±50 (+Vin - COM-in, -Vin - COM-in)
2	Rated Current DC[A]	6
3	Test Voltage (Terminal-Mounting Plate)	500 VAC (Cutoff Current = 100mA), 1minute at room temperature and humidity
4	Isolation Resistance (Terminal-Mounting Plate)	500 VDC 50MΩ min at room temperature and humidity
5	DC resistance	50mΩ max
6	Operating temperature	-40 to +71°C (Refer to Derating Curve)
7	Operating humidity	20 to 95%RH (Non condensing)
8	Storage temperature/humidity	-40 to +75°C/20 to 95%RH (Non condensing)
9	Vibration	10 to 55Hz, 19.6m/s ² (2G), 3min. Period, 1hour each X, Y and Z axis
10	Impact	196.1m/s ² (20G), 11ms Once each X, Y and Z axis
11	Safety agency approvals	UL60950-1, C-UL (CSA60950-1), EN62368-1
12	Case size (without projection) /Weight	52 X 35 X 117 mm [2.05 X 1.38 X 4.61 inches] (W X H X D) /150g max (Option : -D, -T, -DT refer to external view)

Circuit Diagram

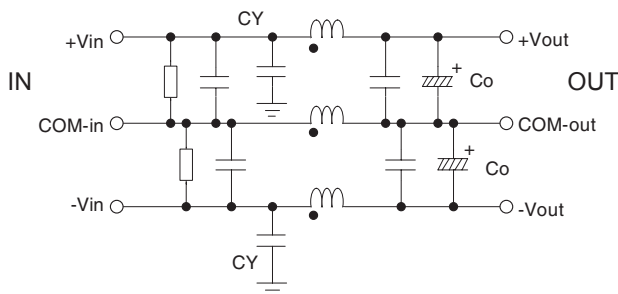

CY : Line to ground capacitor Co : Electrolytic capacitor $\text{---} \text{---} \text{---}$: Mounting Plate

■ Expected life : 10 years

Derating Curve

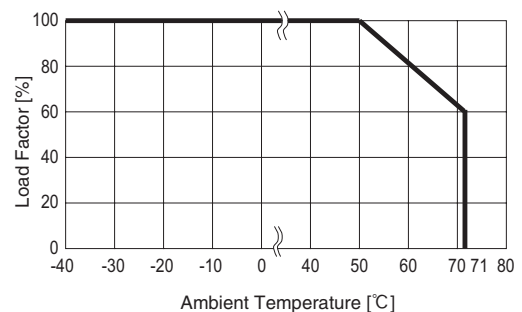

External view

Standard Type

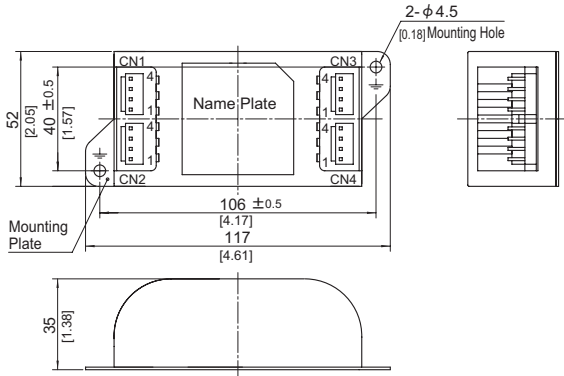

- ※ Tolerance : ±1 [±0.04]
- ※ Weight : 150g max
- ※ PCB Material /thickness : CEM3 /1.6mm [0.06 inches]
- ※ Mounting plate : Iron (surface finishing : nickel plating) t=1.0 [0.04]
- ※ Case : PBT
- ※ Dimensions in mm, []=inches
- ※ Keeping drawing current per pin below 5A for CN1 to CN4

CN1		CN3	
Pin No.	Function	Pin No.	Function
1,2	COM-in	1,2	COM-out
3,4	+Vin	3,4	+Vout

CN2		CN4	
Pin No.	Function	Pin No.	Function
1,2	-Vin	1,2	-Vout
3,4	COM-in	3,4	COM-out

I/O Connector	Mating connector	Terminal
CN1-CN4	B4P-VH VHR-4N	Reel:SVH-21T-P1.1 Bulk:BVH-21T-P1.1

(Mfr:J.S.T)

Option harness : Refer to Instruction Manual 4

Terminal block Type

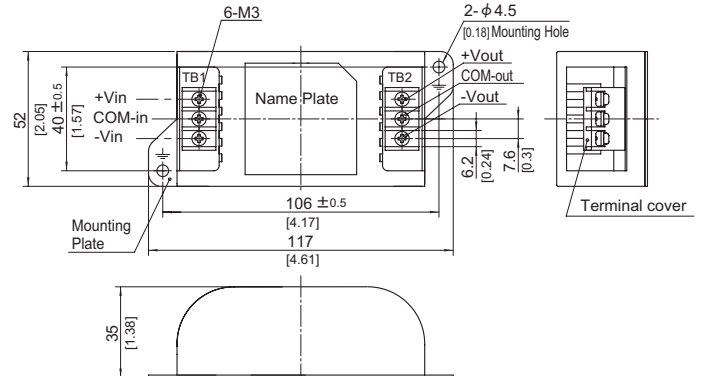

- ※ Tolerance : ±1 [±0.04]
- ※ Weight : 160g max
- ※ PCB Material /thickness : CEM3 /1.6mm [0.06 inches]
- ※ Mounting plate : Iron (surface finishing : nickel plating) t=1.0 [0.04]
- ※ Case : PBT
- ※ Dimensions in mm, []=inches
- ※ Terminal block screw tightening torque M3:0.8N · m (8.5kgf · cm) max

DIN rail installation Type

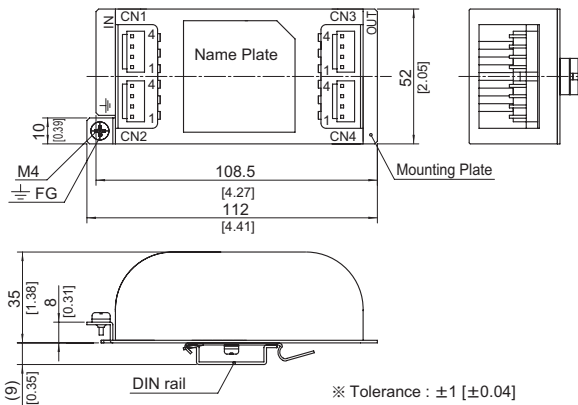

- ※ Tolerance : ±1 [±0.04]
- ※ Weight : 160g max
- ※ PCB Material /thickness : CEM3 / 1.6mm [0.06 inches]
- ※ Mounting plate : Iron (surface finishing : nickel plating) t=1.0 [0.04]
- ※ Case : PBT
- ※ Dimensions in mm, []=inches
- ※ Keeping drawing current per pin below 5A for CN1 to CN4

CN1		CN3	
Pin No.	Function	Pin No.	Function
1,2	COM-in	1,2	COM-out
3,4	+Vin	3,4	+Vout

CN2		CN4	
Pin No.	Function	Pin No.	Function
1,2	-Vin	1,2	-Vout
3,4	COM-in	3,4	COM-out

I/O Connector	Mating connector	Terminal
CN1-CN4	B4P-VH VHR-4N	Reel:SVH-21T-P1.1 Bulk:BVH-21T-P1.1

(Mfr:J.S.T)

Option harness : Refer to Instruction Manual 4

Terminal block type+DIN rail installation Type

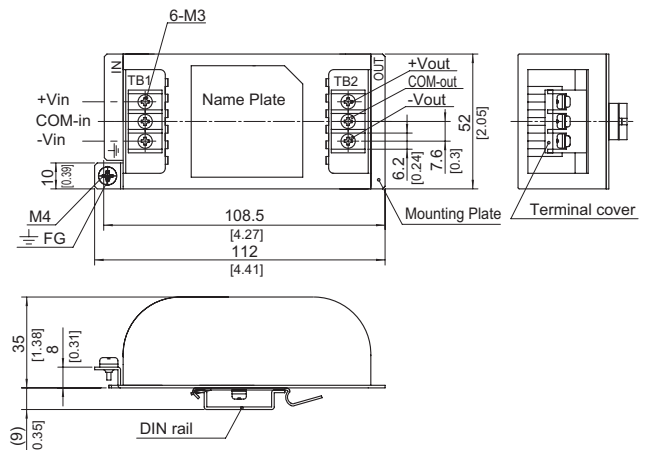

- ※ Tolerance : ±1 [±0.04]
- ※ Weight : 170g max
- ※ PCB Material /thickness : CEM3 /1.6mm [0.06 inches]
- ※ Mounting plate : Iron (surface finishing : nickel plating) t=1.0 [0.04]
- ※ Case : PBT
- ※ Dimensions in mm, []=inches
- ※ Terminal block screw tightening torque M3:0.8N · m (8.5kgf · cm) max

Note when installing the EMI/EMC Filter on a DIN rail.

When the EMI/EMC Filter is grounded through the DIN rail, the proper noise attenuation may not be achieved.

Be sure to connect the FG terminal of the EMI/EMC Filter body to the earth.

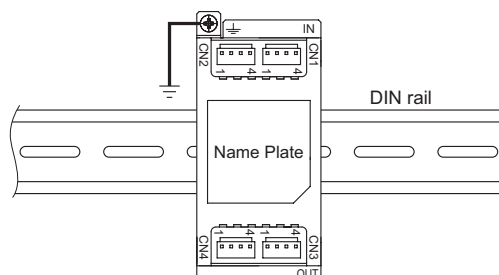

SNR series (10A)

SNR -10 -223 -□

① ② ③ ④

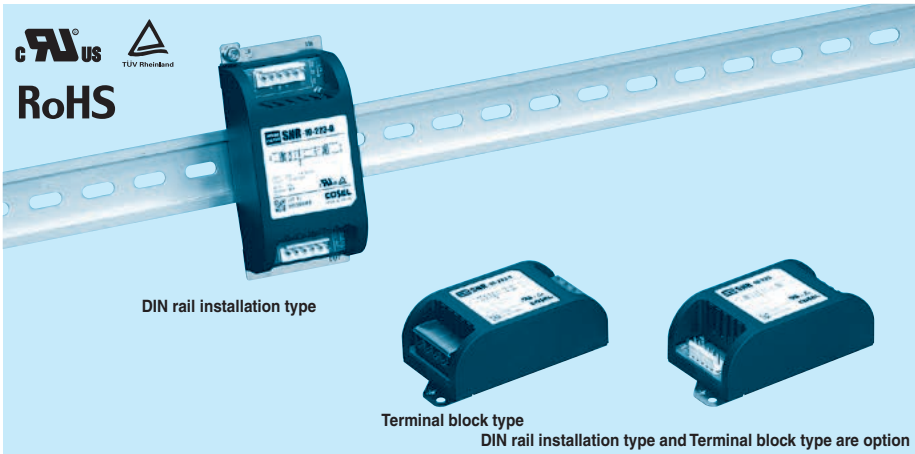

- ① Model Name
- ② Rated Current
- ③ Line to ground capacitor code: See table 1.1.

table 1.1 Line to ground capacitor code

Code	Line to ground capacitor (nominal value)
000	Not Provided
223	22000pF

- ④ Options
- D :DIN rail installation type
- T :Terminal block type
- DT :Terminal block and DIN rail type

* The dimensions change when the option is set. Refer to External view.

Features of SNR series (10A)

Ripple noise attenuation type for switch mode power supplies(DC)

· 50 VDC

· Best filter for switch mode power supplies of analog circuits

Specifications

No.	Items	SNR-10-223	
		Interface:Connector	
1	Rated Voltage DC[V]	50	
2	Rated Current DC[A]	*1	10 (Peak 20)
3	Test Voltage (Terminal-Mounting Plate)	500 VAC (Cutoff Current = 100mA), 1minute at room temperature and humidity	
4	Isolation Resistance (Terminal-Mounting Plate)	500 VDC 50MΩ min at room temperature and humidity	
5	DC resistance	20mΩ max	
6	Operating temperature	-40 to +71°C (Refer to Derating Curve)	
7	Operating humidity	20 to 95%RH (Non condensing)	
8	Storage temperature/humidity	-40 to +75°C/20 to 95%RH (Non condensing)	
9	Vibration	10 to 55Hz, 19.6m/s ² (2G), 3min. Period, 1hour each X, Y and Z axis	
10	Impact	196.1m/s ² (20G), 11ms Once each X, Y and Z axis	
11	Safety agency approvals	UL60950-1, C-UL (CSA60950-1), EN62368-1	
12	Case size (without projection) /Weight	52 X 35 X 117 mm [2.05 X 1.38 X 4.61 inches] (WXHXD) /140g max (Option : -D, -T, -DT refer to external view)	

*1 Peak current for 10 sec. And Duty 35% max, refer to Instruction Manual 5. In detail.

Circuit Diagram

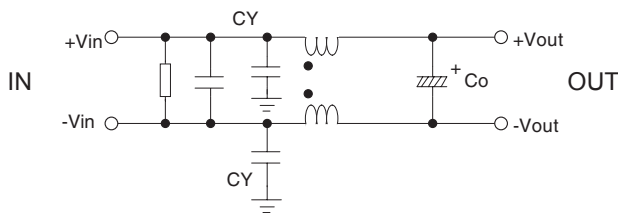

CY : Line to ground capacitor Co : Electrolytic capacitor $\text{---} \text{---} \text{---}$: Mounting Plate

■ Expected life : 10 years

Derating Curve

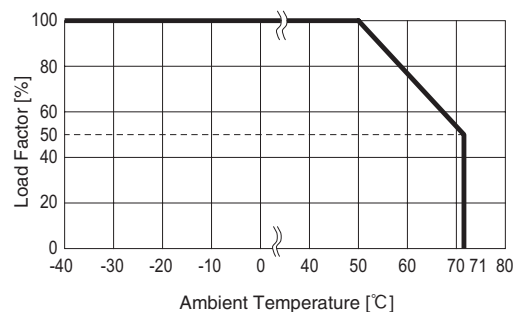

External view

Standard Type

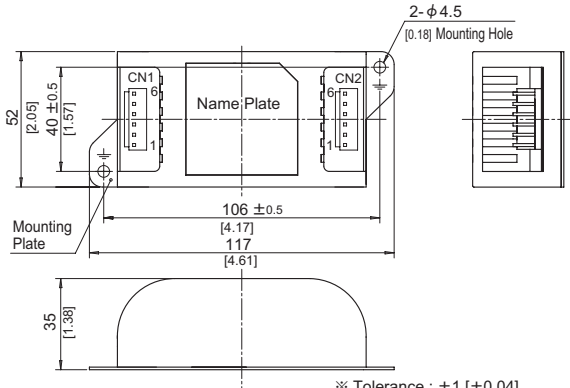

- ※ Tolerance : ± 1 [± 0.04]
- ※ Weight : 140g max
- ※ PCB Material /thickness : CEM3 /1.6mm [0.06 inches]
- ※ Mounting plate : Iron (surface finishing : nickel plating) $t=1.0$ [0.04]
- ※ Case : PBT
- ※ Dimensions in mm, []=inches
- ※ Keeping drawing current per pin below 5A (7A at peak current) for CN1 to CN2

CN1		CN2	
Pin No.	Function	Pin No.	Function
1,2,3	-Vin	1,2,3	-Vout
4,5,6	+Vin	4,5,6	+Vout

I/O Connector	Mating connector	Terminal
CN1,CN2	B6P-VH	VHR-6N
		Reel:SVH-21T-P1.1
		Bulk:BVH-21T-P1.1

(Mfr:J.S.T)

Option harness : Refer to Instruction Manual 4

Terminal block Type

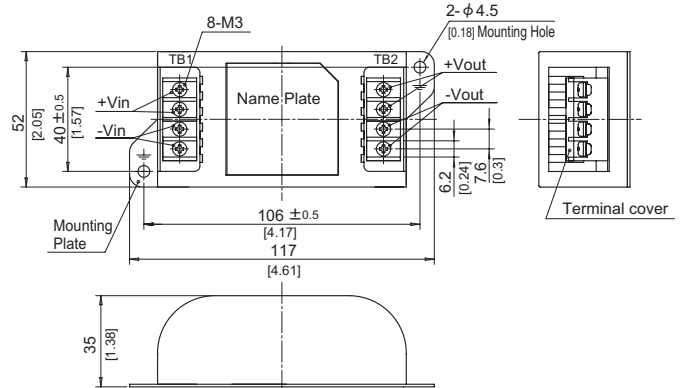

- ※ Tolerance : ± 1 [± 0.04]
- ※ Weight : 150g max
- ※ PCB Material /thickness : CEM3 /1.6mm [0.06 inches]
- ※ Mounting plate : Iron (surface finishing : nickel plating) $t=1.0$ [0.04]
- ※ Case : PBT
- ※ Dimensions in mm, []=inches
- ※ Terminal block screw tightening torque $M3:0.8N \cdot m$ (8.5kgf \cdot cm) max
- ※ Keeping drawing current per pin below 8A (10A at peak current) for TB1 to TB2

DIN rail installation Type

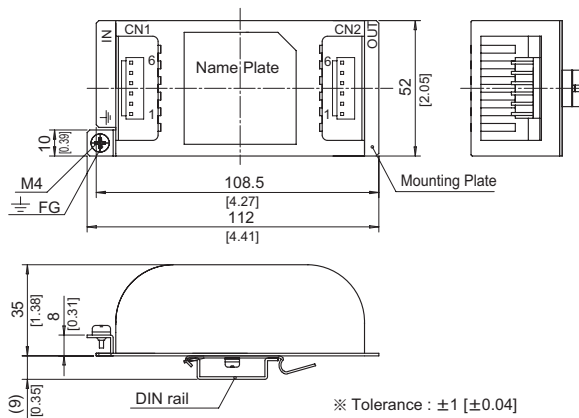

- ※ Tolerance : ± 1 [± 0.04]
- ※ Weight : 150g max
- ※ PCB Material /thickness : CEM3 / 1.6mm [0.06 inches]
- ※ Mounting plate : Iron (surface finishing : nickel plating) $t=1.0$ [0.04]
- ※ Case : PBT
- ※ Dimensions in mm, []=inches
- ※ Keeping drawing current per pin below 5A (7A at peak current) for CN1 to CN2

CN1		CN2	
Pin No.	Function	Pin No.	Function
1,2,3	-Vin	1,2,3	-Vout
4,5,6	+Vin	4,5,6	+Vout

I/O Connector	Mating connector	Terminal
CN1,CN2	B6P-VH	VHR-6N
		Reel:SVH-21T-P1.1
		Bulk:BVH-21T-P1.1

(Mfr:J.S.T)

Option harness : Refer to Instruction Manual 4

Terminal block type+DIN rail installation Type

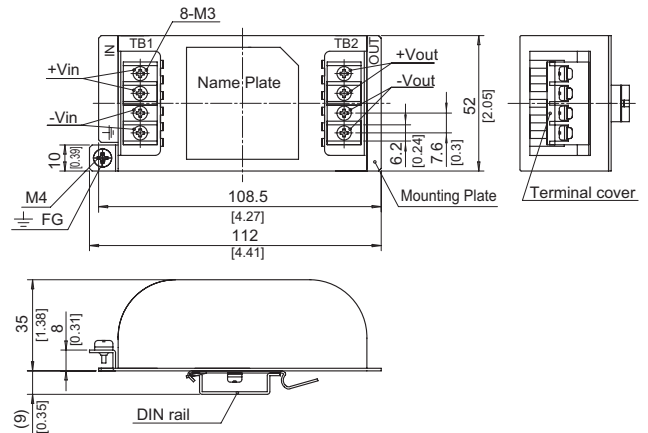

- ※ Tolerance : ± 1 [± 0.04]
- ※ Weight : 160g max
- ※ PCB Material /thickness : CEM3 /1.6mm [0.06 inches]
- ※ Mounting plate : Iron (surface finishing : nickel plating) $t=1.0$ [0.04]
- ※ Case : PBT
- ※ Dimensions in mm, []=inches
- ※ Terminal block screw tightening torque $M3:0.8N \cdot m$ (8.5kgf \cdot cm) max
- ※ Keeping drawing current per pin below 8A (10A at peak current) for TB1 to TB2

Note when installing the EM/EMC Filter on a DIN rail.

When the EM/EMC Filter is grounded through the DIN rail, the proper noise attenuation may not be achieved.

Be sure to connect the FG terminal of the EM/EMC Filter body to the earth.

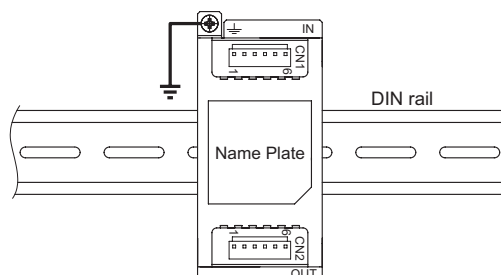

SNA-01-223

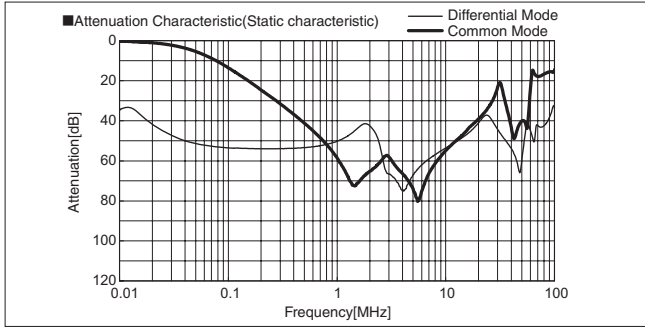

SNA-03-223

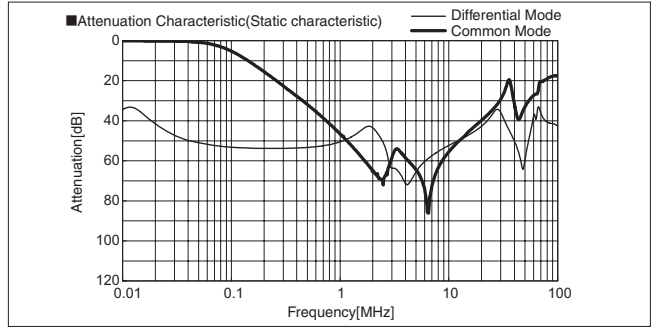

SNA-06-223

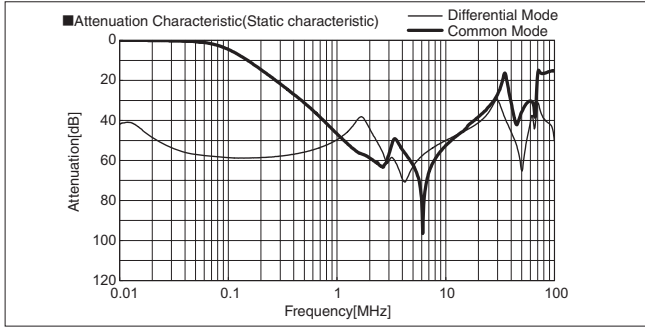

SNR-10-223

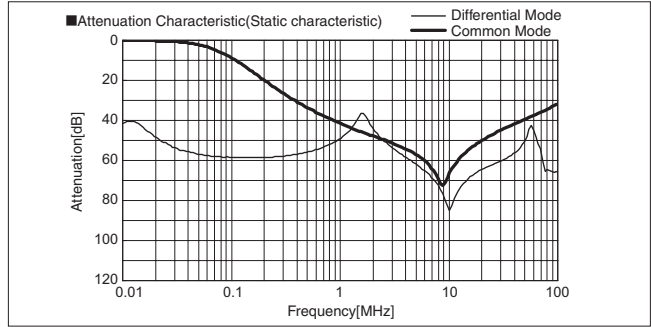

※ This product only reduces ripple noise of the switch mode power supply. It cannot be used effectively to reduce ripple noise at line frequency.

Example of attenuation output noise.

LCA10S-12

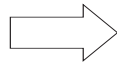
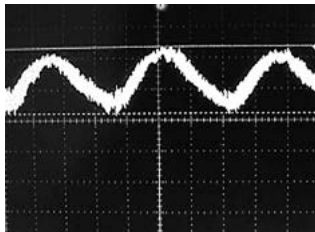

LCA10S-12+SNA-01-223

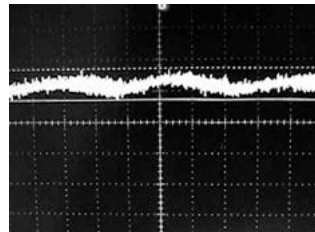

(Room temp, Room Humi)
BW:500MHz
LCA10S-12
12V 0.9A

LCA30S-12

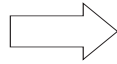
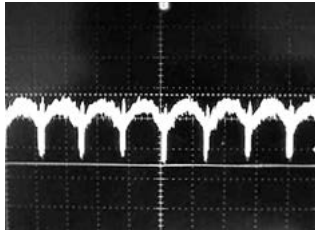

LCA30S-12+SNA-03-223

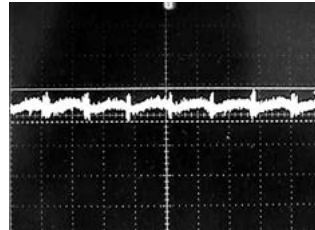

(Room temp, Room Humi)
BW:500MHz
LCA30S-12
12V 2.5A

LCA50S-12

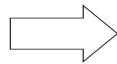
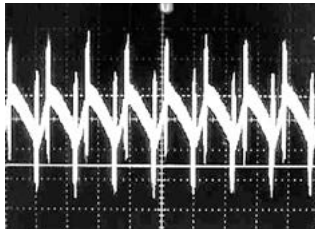

LCA50S-12+SNA-06-223

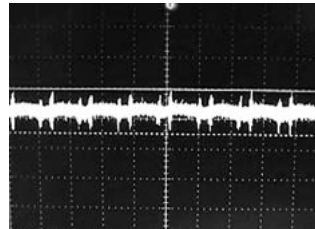

(Room temp, Room Humi)
BW:500MHz
LCA50S-12
12V 4.3A

LEP240F-24

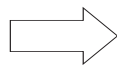
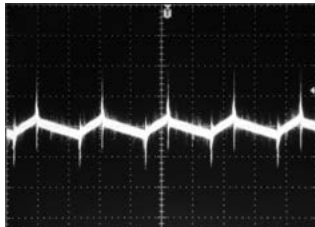

LEP240F-24+SNR-10-223

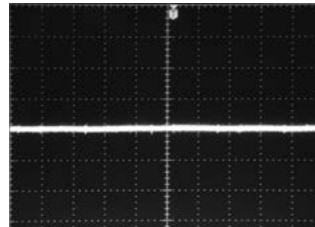

(Room temp, Room Humi)
BW:500MHz
LEP240F-24
24V 10A

※ Measured by differential probe (KEISOKU-GIKEN:DP-100).

1 Wiring to Input/Output terminals

■ This filter uses polarized components (electrolytic capacitor), The filter will break if reverse voltage is applied to the input/output terminals. Please exercise caution when wiring.

2 Application examples

■ Power supply for an operational amplifier.

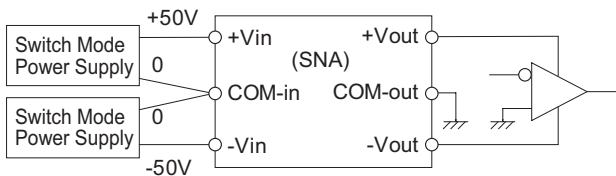

■ Single output power supply.

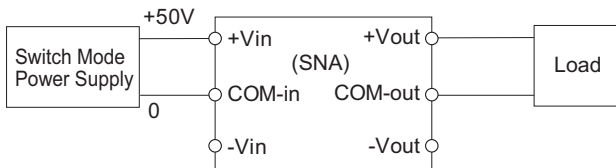

3 Safety Considerations

■ To apply for safety standard approval using this EMI/EMC Filter, the following conditions must be met.

- The unit must be used as a component of an end-use equipment.
- The unit must be used in the secondary circuit that is insulated from the primary circuit through double or reinforced insulation.
- The mounting plate (FG) must be connected to safety ground of end-use equipment.

4 Optional Parts

■ The harness for Input/Output of EMI/EMC Filter is available.

Model	Harness model
SNA-01	H-OU-8
SNA-03	H-OU-8
SNA-06	H-OU-9
SNR-10	H-OU-18

※ The same harness model applies to both input and output.

※ Sold in units of 1 piece.

5 Peak current (SNR)

■ Peak current is possible to draw as below.

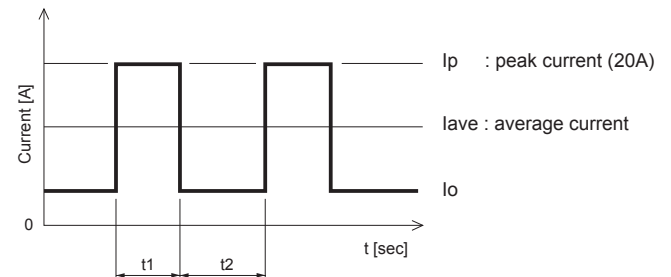

$$t1 \leq 10 \text{ [sec]}, I_{ave} = \frac{I_p \cdot t1 + I_o \cdot t2}{t1 + t2} \leq \text{rated current}$$

$$\frac{t1}{t1 + t2} \leq \text{Duty}$$

Duty is depended on peak current, refer to below chart.

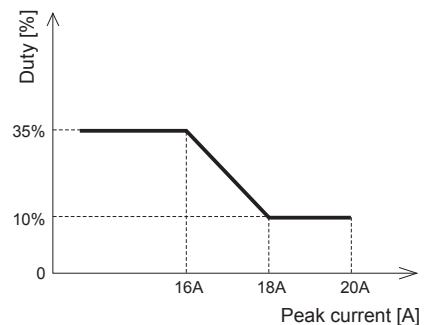

(1) Attenuation Characteristic(Static characteristic)

※ Attenuation= $20\log(U_{b1}/U_{b2})$ (dB)
 U_{b1} : Voltage in state without filters
 U_{b2} : Voltage in state which added filters
 ※ N.A.: Network analyzer

■Object product : Single-phase input type (Differential mode)

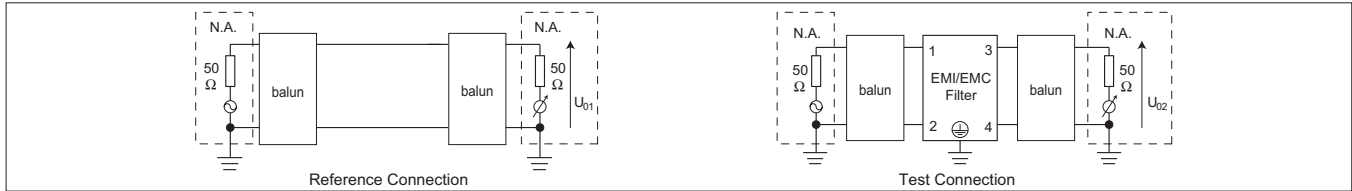

■Object product : Single-phase input type (Common mode)



■Object product : Three-phase three-wire system (Differential mode)

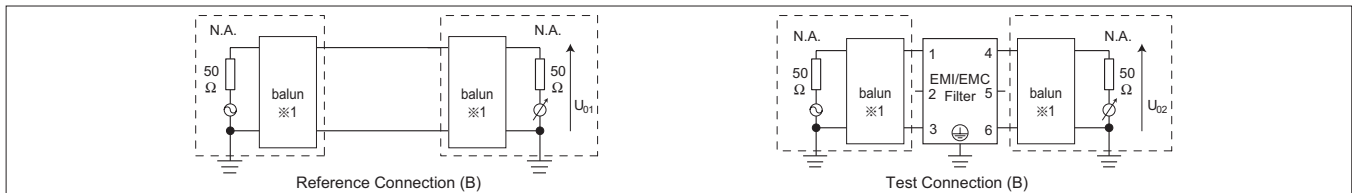
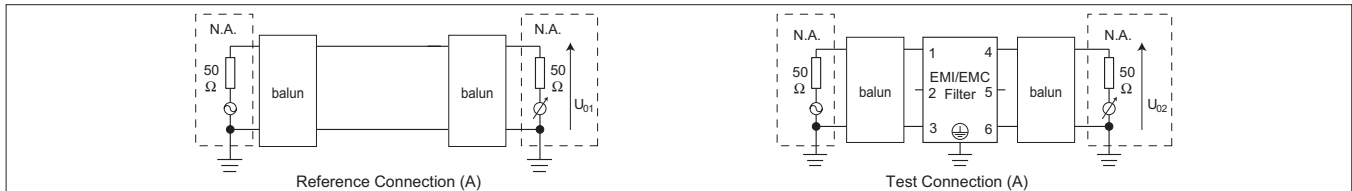

※ Measured with the above test circuit (A) or (B)
 ※1 Equilibrium measurement with mixed-mode S-parameters in the instrument

■Object product : Three-phase three-wire system (Common mode)



■Object product : Three-phase four-wire system (Differential mode)

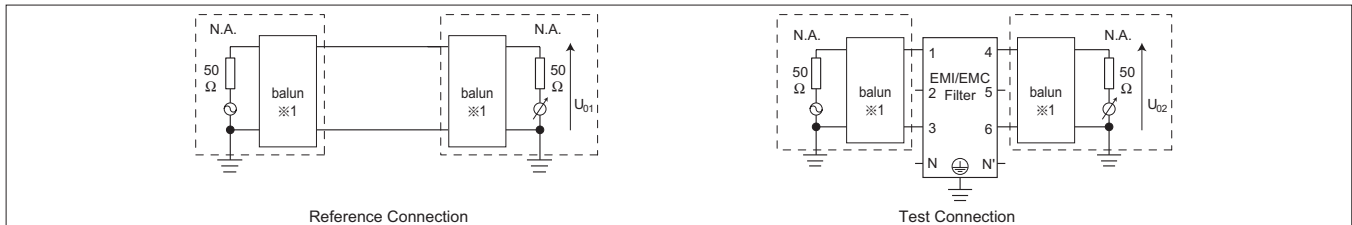

※1 Equilibrium measurement with mixed-mode S-parameters in the instrument

■Object product : Three-phase four-wire system (Common mode)

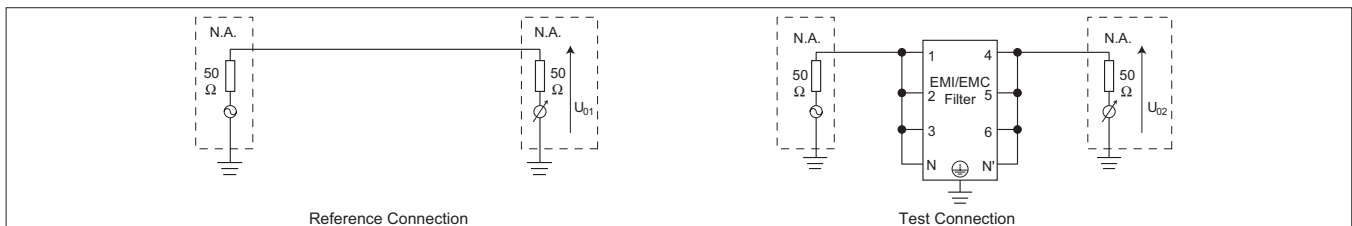

※ Attenuation = $20\log(U_{01}/U_{02})$ [dB]
 U_{01} : Voltage in state without filters
 U_{02} : Voltage in state which added filters
 ※ N.A. : Network analyzer

■ Object product : DC input type (Differential mode)

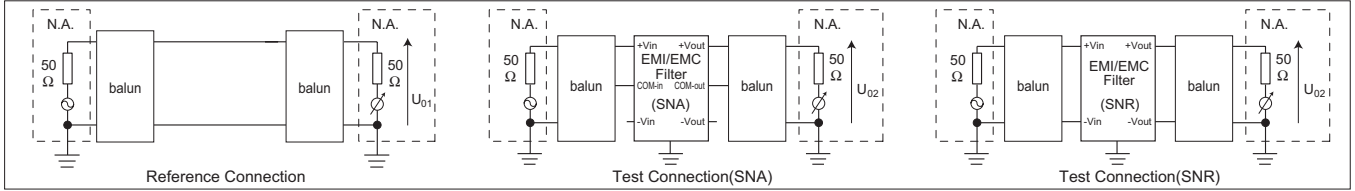

■ Object product : DC input type (Common mode)

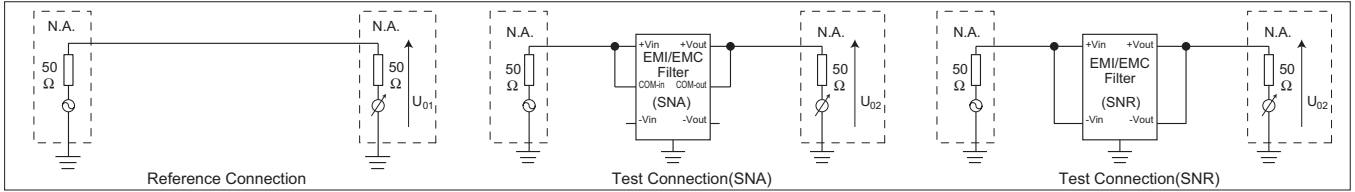

(2) Pulse Attenuation Characteristic

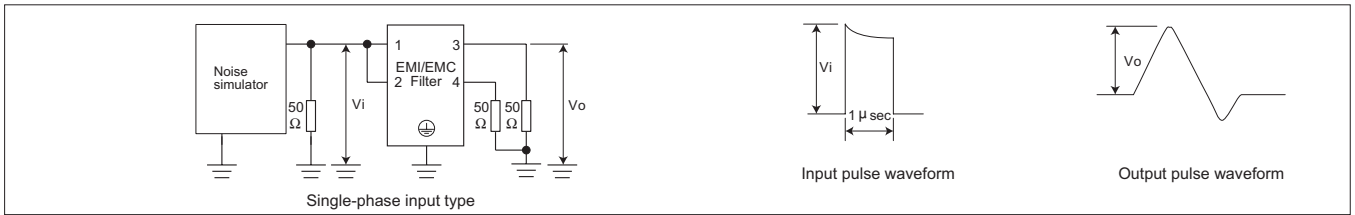



□ Head Office

COSEL CO., LTD.

1-6-43 Kamiakae-machi, Toyama 930-0816, Japan

☎ Phone +81-76-432-8152

✉ E-mail sales@cosel.co.jp

🌐 URL www.cosel.co.jp/en

□ Worldwide Sales / Support Network

[AMERICA]

COSEL U.S.A., INC.

☎ Phone (Free) +1-888-661-1705

✉ E-mail sales@coselusa.com

🌐 URL www.coselusa.com

《Engineering and Technical Support》

☎ Phone (Free) +1-888-661-1692

✉ E-mail techsupport@coselusa.com

[EUROPE]

COSEL EUROPE GmbH

☎ Phone +49-69-95 00 79-0

✉ E-mail sales@coseurope.eu

🌐 URL www.coseurope.eu

《Engineering and Technical Support》

✉ E-mail techsupport@coseurope.eu

[ASIA]

COSEL ASIA LTD.

☎ Phone +852-2305-2712

✉ E-mail sales@coselasia.com

🌐 URL www.coselasia.com

COSEL (SHANGHAI) ELECTRONICS CO., LTD.

☎ Phone +86-21-6440-0381

✉ E-mail sales@coselasia.cn

🌐 URL www.coselasia.cn

PRODUCT
CATALOG
2023
2024

Distributor: